

Scuba Series Wide Angle™

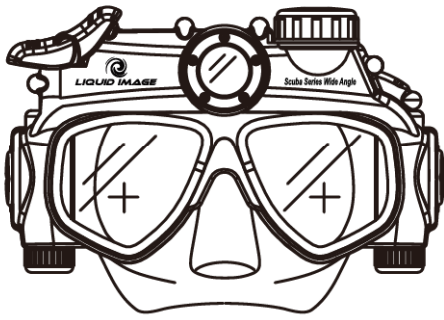

User Manual - Underwater Digital Camera Mask

사용 설명서 - 수중 디지털 카메라 마스크

使用手冊 - 水下摄影面具

ユーザーマニュアル - 水中デジタルカメラマスク

คู่มือการใช้งาน - แวนตาว่ายน้ำกล้องดิจิทัล

ENGLISH

한국어

中文

日本語

ไทย

ENGLISH

ATTENTION

This manual explains how to safely operate the Underwater Digital Camera Mask. **Please read these instructions carefully before using the camera.**

Keep this manual in a safe place for later reference

Disclaimer

While every effort has been made to ensure that the information contained in the guide is accurate and complete, no liability can be accepted for any errors or omissions. Liquid Image Co reserves the right to change the specifications of the hardware and software described herein at any time without prior notice.

Liquid Image Co declines all responsibility for damages due to improper use of this product, failure to adhere to the instructions given in this manual, or modifications to the UNDERWATER DIGITAL CAMERA MASK.

Cautions concerning data storage: Stored data may be lost or corrupted. It is recommended that any important data be copied onto a separate media (such as a hard disk, DVD-R or CD-R disk). Liquid Image Co makes no warranties and shall not be held responsible for damages resulting from corrupted or lost data due to a malfunction of the camera, the software, the memory cards, personal computer, peripheral devices, use of memory cards, or for any losses that result from images that could not be recorded, are erased, destroyed, or damaged in any way due to a problem or a mistake while utilizing the camera or any of its accessories.

**The Underwater Digital Camera Mask is a sophisticated electronic device and should be supervised by an adult at all times. This product should not be used by children under 13 years. This product is not a toy. The inserting of memory cards, USB cable, and batteries must be performed by an adult 18 years or older who has read and understands this manual. An adult must always check all water tight compartments prior to each use.**

Products mentioned above or throughout the manual may be trademarks or registered trademarks of their respective companies.

CONTENTS

1.0 Get to know your Camera Mask - Scuba Series Wide Angle™	
1.1 Features	ENG- 2
1.2 Specifications	ENG- 2
1.3 System requirements	ENG- 2
2.0 Functional Parts	
2.1 Included Parts and accessories	ENG- 3
2.2 Part Names - Front View	ENG- 4
2.3 Part Names - Back View	ENG- 5
2.4 Part Names - Exploded View	ENG- 6
3.0 Set up	
3.1 Inserting or Replacing Batteries	ENG- 7
3.2 Inserting Micro SD/SDHC Memory Card	ENG- 8
3.3 Setting the Date and Time Mode	ENG- 9
3.4 Camera Lock	ENG- 9
4.0 Recording Pictures and Video	
4.1 Video Mode	ENG-10
4.2 Still Image Mode	ENG-10
4.3 Power Off	ENG-10
5.0 Transferring Still Images and Video to a Computer	
5.1 Opening Memory Compartment	ENG-11
5.2 Connecting and Transferring Files	ENG-11
5.3 Disconnecting and Closing Memory Compartment	ENG-12
6.0 Viewing Videos and Still Images on TV	
6.1 Setting Correct NTSC/PAL Mode for your TV	ENG-13
6.2 Video and Still Image Playback on a TV	ENG-14
7.0 Camera Test Instructions	
7.1 Part One - Taking Test Images and Videos	ENG-14
7.2 Part Two - File Size Test	ENG-15
7.3 Part Three - Using the Cross Hairs (View Finders)	ENG-16
7.4 Part Four - Testing the CAMERA MASK in water	ENG-17
8.0 Using the Arcsoft Software	
8.1 Installation	ENG-17
8.2 Photo Editing	ENG-18
8.3 Video Editing	ENG-18
9.0 Care and Maintenance	ENG-18
10.0 Camera Warnings and Precautions	ENG-20
11.0 Mask Warnings and Precautions	ENG-21
12.0 Battery Warnings and Precautions	ENG-22
13.0 Commonly Asked Questions and Troubleshooting	ENG-23
14.0 Accessories, Firmware, and Software	ENG-25

1.0 GET TO KNOW YOUR CAMERA MASK



1.1 Features

- Still Images
- Video Clips
- Micro SD/SDHC Card support
- Driver free for Windows 2000/ME/XP/Vista/7 and Mac 9.x or X.x

1.2 Specifications - Subject to change without notice

Sensor	5.0MP CMOS sensor
Image Resolution *	5.0 Megapixels (2592x1944)
Lens	F/3.2 f=3.02mm
Focus range	1.2m to infinity
Internal Memory	32MB NAND Flash Memory for CPU only
External Memory Card	Micro SD/SDHC Card supports up to 32GB
Video Mode **	30FPS@HD 720P (1280X720) with Audio
File Format	Picture: JPEG, Video: H.264 with Audio
Status Display	LCD Display
PC Interface	USB
TV Output	PAL and NTSC
Power	4 AAA 1.5V (LR03, FR03) Alkaline, Energizer® Lithium, or 1.2V NiMH
Auto Off System time	180 seconds

\* Quantity of pixels is only an approximate number \*\* Approximate frames per second

1.3 System Requirement \*\*\*

Operating System	Windows 2000/ME/XP/Vista/7 and Mac 9.x or X.x
CPU	Pentium II or above
RAM	At least 64MB
Interface	USB port
CD	4x speed CD ROM or above

## 2.0 Functional Parts

### 2.1 Included Parts and Accessories

Please check the contents now (before use) to confirm that it is complete.  
Contact your Liquid Image Co dealer if anything is missing.

USER MANUAL  
UNDERWATER DIGITAL CAMERA MASK - Scuba Series Wide Angle™  
RCA / USB CABLE  
CD ROM WITH THIRD PARTY SOFTWARE - PC VERSION ONLY  
WARRANTY

Accessories may include:

CARRYING CASE  
BATTERIES  
SILICONE GREASE TUBE  
MICRO SD/SDHC CARD

NOTE: The UNDERWATER DIGITAL CAMERA MASK will be referred to as the "CAMERA MASK" throughout this instruction manual.

"Under the environment with radio frequency Interference, the USB link between the CAMERA MASK and the computer may not be maintained. Just follow the instruction described in this manual to set the function again for normal operation."

**WARNING: NEVER OPEN THE CAMERA BODY THAT IS FACTORY SEALED WITH SCREWS. THIS WILL VOID ANY WARRANTY. NEVER USE A SCREW DRIVER TO OPEN ANY PORTION OF THE CAMERA MASK.**

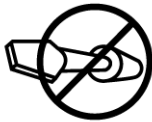

ENG-3

## 2.2 Part Names - Front View

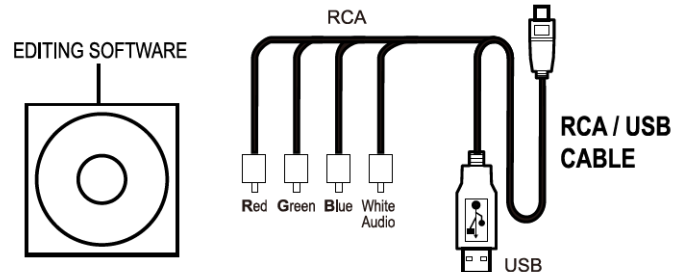
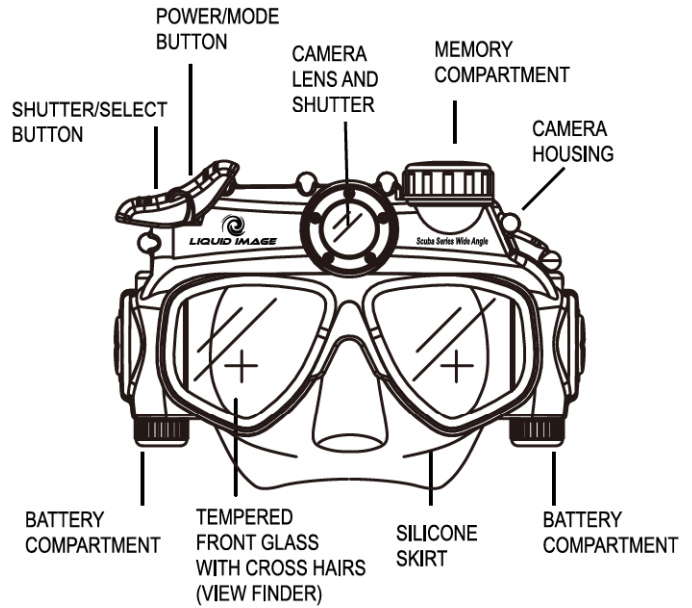

ENG-4

## 2.3 Part Names - Back View

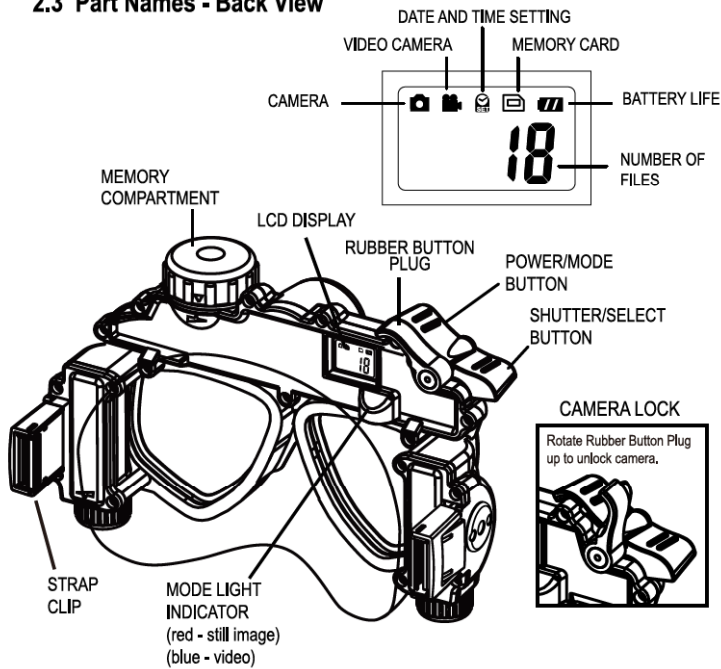

### WATER PROOFING CAPS

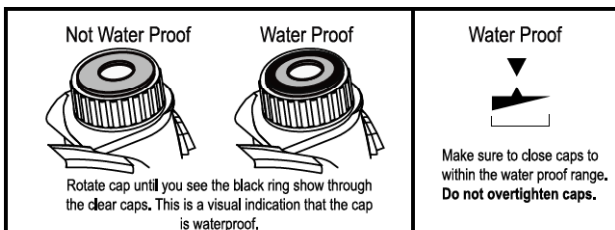

ENG-5

## 2.4 Part Names - Exploded View

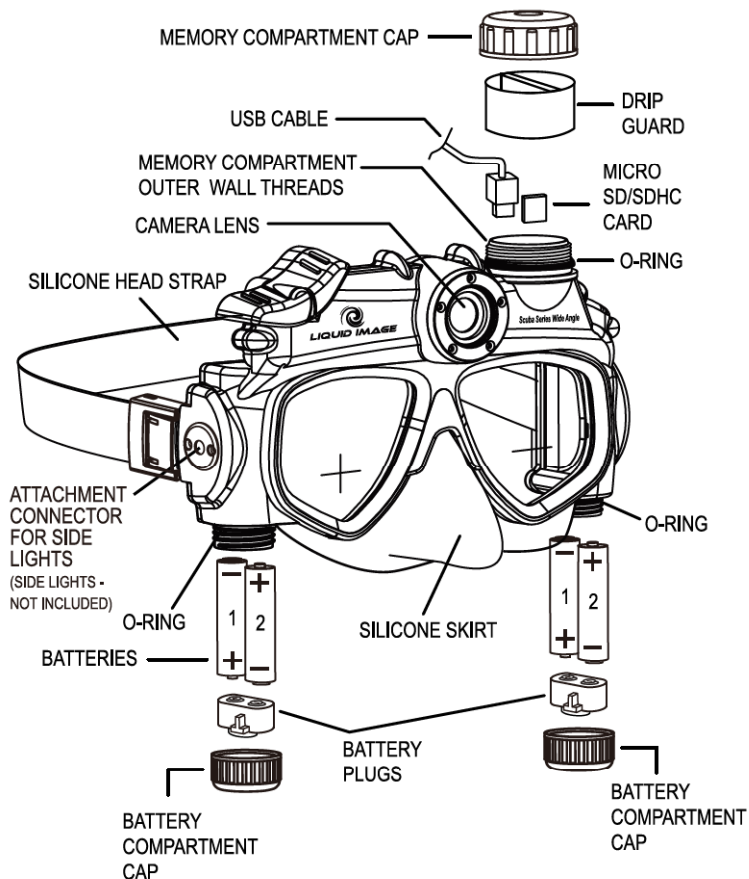

ENG-6

### 3.0 CAMERA MASK SET UP

**CAUTION:** An adult 18 years or older should perform this function. Always make sure the CAMERA MASK is completely dry before performing these steps. Set up should always take place in a clean dry space with a controlled environment. These steps should be performed indoors to avoid exposure to the elements.

#### 3.1 Inserting or Replacing Batteries

You may use AAA Alkaline, AAA Lithium, or AAA NiMH batteries to power the CAMERA MASK (1.5V AAA, LR03, FR03). **NOTE:** We suggest using Energizer® Lithium batteries to power this product. The battery life is approximately 10 times longer than alkaline batteries when used in the CAMERA MASK.

**NOTE:** The LCD indicator shows battery life. When no remaining bars are displayed, the battery is low and the LCD screen will show the word "LO" and will make a beeping sound. Replace batteries to continue using. Files on the Micro SD/SDHC card will not be lost if battery power runs out or during replacement of the batteries.

**CAUTION:** Always insert four new batteries of the same type and brand. Do not mix different types of batteries. Follow all instructions from the battery manufacturer of the batteries that you use.

To insert or replace batteries:

1. Locate the BATTERY COMPARTMENT.
2. Open the BATTERY COMPARTMENT. Remove the cap slowly.
3. Locate and remove the BATTERY PLUG. **CAUTION:** Do not lose this part. The CAMERA MASK will not function without this part.
4. Remove and dispose of the old batteries in accordance with local laws.
5. Insert the new batteries in accordance with the Diagram inside the BATTERY COMPARTMENT on the CAMERA MASK.
6. Reinsert the BATTERY PLUG.
7. Close the BATTERY COMPARTMENT to the water proof range marked on the mask housing (detail pg5). Do not overtighten cap.

ENG-7

#### Estimated Battery life for Lithium AAA batteries

Lithium AAA (Energizer®) Battery  
Still image mode: up to 2000 pictures  
Video clip recording mode: up to 240 minutes

**Note:** Battery life indicator will show half bar  when fully charged 1.2V rechargeable batteries are being used.

#### 3.2 Inserting Micro SD or SDHC Memory Card - Mandatory

**NOTE:** A Micro SD/SDHC Memory Card may or may not be included with your CAMERA MASK. It is recommended that you utilize a commercially sold Micro SD/SDHC Card to add memory storage to your CAMERA MASK. It is best to utilize a high performance Micro SD/SDHC card as this will improve the performance of your CAMERA MASK. This CAMERA MASK works with both a Micro SD card or a Micro SDHC card up to 32 GB. Carefully read the instructions and warnings that come with the card. If your card is not FAT16 formatted, it will be reformatted once placed into the Micro SD/SDHC card slot on your Camera Mask and the Power is turned on. Please note that any data on the card will be lost. Make sure to back up any data on the Micro SD/SDHC Card prior to inserting into the camera mask.

**NOTE:** The Scuba Series Wide Angle™ Camera Mask does not have internal memory to store the images and videos taken by the CAMERA MASK. You must insert a Micro SD/SDHC card prior to taking images and videos.

Approximate File Storage

Micro SDHC Card 32GB  
Images: 36800  
Video: 960 minutes

To insert a Micro SD/SDHC Memory Card into your CAMERA MASK:

1. Locate the MEMORY COMPARTMENT on the top of the CAMERA MASK. (This compartment also houses the USB port.)
2. Open the MEMORY COMPARTMENT.
3. Locate and remove the rubber DRIP GUARD. **CAUTION:** Do not lose this part. The DRIP GUARD is part of the water proofing system.
4. Insert the Micro SD/SDHC Card in accordance with the diagram next to the card port. **CAUTION:** Liquid Image Co, LLC is not responsible for damage to the CAMERA MASK or to the memory card if the card is inserted improperly.
5. Reinsert the rubber DRIP GUARD into the MEMORY COMPARTMENT.
6. Close the MEMORY COMPARTMENT to the water proof range marked on the mask housing (detail pg5). Do not overtighten cap.

ENG-8

### 3.3 Setting the Date and Time Mode

This feature allows you to set the Date and Time to the photo or video file.

1. Press and hold the SHUTTER/SELECT button down. Then press the POWER/MODE button once. The camera will turn on.
2. Continue holding the SHUTTER/SELECT button down and press the POWER/MODE button 3 times continuously and then release the SHUTTER/SELECT button. The LCD screen will access the Time Setting mode. You will be able to change Year (YYYY), Month (MM), Day (DD), Hour (hh), and Minute (mm). The first window will be YYYY for Year. Press the SHUTTER/SELECT button and the numbers will appear (ie.2010). The first number "2" in the year will start blinking.
3. Press the POWER/MODE button to change the blinking character from 0-9. Press the SHUTTER/SELECT button to select the number and move onto the next number "0". The setting process is from the left to right and will go through the different settings from Year, Month, Day, Hour, and minute. Once the number is confirmed by pressing the SHUTTER/SELECT button, the next digit will start blinking. Once you see the letters again such as MM for Month, press the SHUTTER/SELECT button to move to the numbers representing the month. Continue the process until you return to YYYY.
4. To get out of the Date and Time Setting Mode, press and hold the SHUTTER/SELECT button for 2 seconds. The CAMERA MASK will return to the still image mode (RED LED).
5. In case the battery needs to be replaced or the battery runs out, the date setting data will be maintained for 24 hours

#### 3.4 Camera Lock

The RUBBER BUTTON PLUG keeps the CAMERA MASK from turning on during transport or non diving activities. To unlock the POWER/MODE button, pull the Rubber Button Plug out from under the POWER/MODE button and rotate it upwards or downwards.

### 4.0 RECORDING PICTURES AND VIDEO

**CAUTION:** Read and perform the 4 Part CAMERA TEST described in this manual prior to using in the water!

**NOTE:** The CAMERA MASK has 2 modes and pressing the POWER/MODE button

cycles through the modes in the following order: Video and Still Image. To advance to the next mode, press the POWER/MODE button one time. The camera will remain on and ready to use for 180 seconds, after which the CAMERA MASK will turn off automatically. If you press and hold the POWER/MODE for more than 1 second, the camera will also turn off.

#### 4.1 Video Mode - BLUE LIGHT

1. Press the POWER/MODE button for at least 1 second. The camera turns on. The camera will power up in VIDEO mode.  
**Note:** The BLUE MODE LIGHT INDICATOR is on and the CAMERA MASK is now in the VIDEO MODE READY mode and set to take videos. The LCD screen displays the movie camera icon.
2. Press the SHUTTER/SELECT button once. Recording begins.  
**Note:** The BLUE MODE LIGHT INDICATOR is blinking. The light will continue to blink until the camera stops recording.
3. To stop recording, press the SHUTTER/SELECT button again.

#### 4.2 Still Image Mode - RED LIGHT

1. Press the POWER/MODE button for at least 1 second. The camera turns on.
2. Press the button the POWER/MODE button again for less than a second to change to STILL IMAGE mode.  
**Note:** The RED MODE LIGHT INDICATOR is on and the CAMERA is now in STILL IMAGE READY mode and set to take pictures. The LCD screen displays the camera icon.
3. Press the SHUTTER/SELECT button once. A still image is captured.  
**NOTE:** To capture the sharpest in focus images, it is important that the distance between the camera and the subject is at least 1.2m (47.25 inches).

#### 4.3 Power Off

1. Press the POWER/MODE button for more than 1 second to turn the camera off.
- NOTE:** If either the POWER/MODE or the SHUTTER/SELECT button has not been used in 180 seconds, the CAMERA MASK will turn off automatically.

ENG-9

Download from [www.Somanuals.com](http://www.Somanuals.com). All Manuals Search And Download.

ENG-10

## 5.0 TRANSFERRING STILL IMAGES AND VIDEO TO A COMPUTER

### CAUTION: ALWAYS FOLLOW THE CARE AND MAINTENANCE INSTRUCTIONS FOR RINSING IN FRESH WATER AND DRYING THE CAMERA MASK PRIOR TO OPENING THE MEMORY COMPARTMENT.

The CAMERA MASK has two ways to transfer your image and video files to a computer. The CAMERA MASK comes with a USB cable (RCA/USB CABLE) to connect your CAMERA MASK directly to a computer. You may also choose to purchase and use a commercially sold Micro SD/SDHC Card to store and transfer images and videos that were taken with the CAMERA MASK. The computer does not require software to access the files stored on the CAMERA MASK's Micro SD/SDHC card. The CAMERA MASK will act as an external hard drive when the USB cable connects the camera to a computer

### 5.1 Opening Memory Compartment

1. Make sure the CAMERA MASK is thoroughly clean and dry. Follow the CARE AND MAINTENANCE instructions.
2. Open the MEMORY COMPARTMENT.
3. Locate and remove the rubber DRIP GUARD. Make sure the DRIP GUARD is clean and dry before proceeding. CAUTION: Do not lose this part. The DRIP GUARD is part of the water proofing system.

### 5.2 Connecting and Transferring Files

1. Choose a method to transfer files: USB or Micro SD/SDHC Card.

#### USB TRANSFER

Plug the USB cable into the USB connection port on the computer and then into the USB Port on the CAMERA MASK. Press the POWER/MODE to turn on the CAMERA MASK. NOTE: The USB cable will be able to access the files stored on the Micro SD/SDHC Card.

#### MICRO SD/SDHC CARD TRANSFER

Press down on the Micro SD or SDHC Card gently. The card will pop up for removal. Carefully remove the card and insert it into the Micro SD card adapter that comes with the Micro SD/SDHC Card and then insert the card into your computer's SD Card Slot as directed by the manufacturer.

ENG-11

\* Make sure your computer's SD Card Slot can handle High Capacity SDHC cards as they are different than standard SD cards.

**CAUTION:** Never insert a wet Micro SD/SDHC Card into a card adapter or into a Computer.

2. The connection screen opens on your computer monitor automatically. Choose the option: OPEN FOLDER TO VIEW FILES.

NOTE: If the screen does not automatically open, look for a new hard drive icon on the computer next to your other hard drive icons. Click on the icon to view your image and video files.

3. The image and video files will appear in a folder.
4. Copy the files to a folder on your computer (For example: My Pictures\Hawaii). Alternatively, you may copy the entire folder to your computer.
5. If you wish to delete the data from the CAMERA MASK'S Micro SD/SDHC Card, select the files you wish to delete and press delete on your computer keyboard.
6. Click the close button.

#### NOTE ON MEDIA PLAYERS:

There are multiple media players available online to play the HD (H.264) video files created with the CAMERA MASK. The preferred video player is **QUICKTIME**. If your default computer media player is unable to play the videos, your player may be out of date and you may need to update it online. You may also try using an alternate media player if your computer has one or if you choose to download one from a source that you trust online. **Or, you can play or convert the video to another format using the ArcSoft MediaImpression Software provided.**

### 5.3 Disconnecting and Closing Memory Compartment

1. Safely disconnect the USB from your computer and from the CAMERA MASK. Alternatively, if you transferred files using the SD Card method, disconnect the SD Card from the computer and then remove the Micro SD/SDHC card from the adapter. Reinsert the Micro SD/SDHC Card into your CAMERA MASK.
  2. Reinsert the rubber DRIP GUARD into the Memory compartment and close the Memory compartment cap to the water proof range marked on the mask housing (detail pg5). Do not overtighten cap.
- NOTE: It is recommended that you always delete all the files from your Micro SD/SDHC card after transferring your files to a computer. This will free up space for more images and video files.

ENG-12

## 6.0 VIEWING VIDEOS AND STILL IMAGES ON A TV

The SCUBA SERIES CAMERA MASK can act as a media player and will be able to play videos and pictures directly from your CAMERA MASK onto a television set. The RCA/USB CABLE is included to connect the CAMERA MASK with a television set.

### IMPORTANT!

Make sure your camera is set to the correct NTSC or PAL video setting or your CAMERA MASK will not work properly with your TV for either Video or photo playback. Select NTSC if viewing on a TV in North America. Choose PAL if viewing on a TV outside of North America or if viewing on a PAL TV in any region.

\* If the USB connection is suddenly interrupted, disconnect the RCA / USB cable connections from the TV and turn off the camera. Restart the camera, and then use RCA / USB cable to connect the camera and TV.

### 6.1 Setting correct NTSC/PAL mode for your TV

This feature allows you to set the TV video output mode to PAL or NTSC. Please check your Television Set to see if the TV can accept either PAL or NTSC video playing devices. The CAMERA MASK is set at the factory in the PAL mode. If you need to change the output mode to NTSC or vice versa, follow the below directions.

1. Press and hold the SHUTTER/SELECT button down and then press and hold the POWER/MODE button down. The RED LED light will turn on. Wait 5 seconds after the RED LED turns on and then release both buttons. You are now in the TV Video Output setup mode and will see one of the following screens:



2. To change the TV video output mode from PAL to NTSC or from NTSC to PAL, press the POWER/MODE button once. You may cycle between the two output modes by pushing the POWER/MODE button again.
3. To Select the TV output mode of either PAL or NTSC, press the SHUTTER/SELECT button once and the camera will save your selected mode, exit the TV video output mode, and return to the Picture mode (RED LED).
4. To complete the TV video output mode setting on the CAMERA MASK, restart the CAMERA MASK by pressing the POWER/MODE button for more than a few seconds until the camera turns off. Press the POWER/MODE button again to restart the CAMERA MASK. Your camera will now be setup in the TV Video Output mode that you selected. You do not have to redo this procedure if you replace batteries. The CAMERA MASK will remain in this mode until you decide to change the TV video output mode through the steps above.

ENG-13

Download from [www.Somanuals.com](http://www.Somanuals.com). All Manuals Search And Download.

## 6.2 VIDEO AND STILL IMAGE PLAYBACK ON A TV

1. Turn off the camera, plug the USB cable of the RCA/USB cable into the camera mask, and connect the RCA side of the RCA / USB cable to the TV. Turn on the camera, it will enter into video playback mode automatically and play the first video. It will stop when the video playback is end. Press the SHUTTER/SELECT button to advance to the next video, press the POWER/MODE button to return to the previous video. Press and hold POWER/MODE button for 3 seconds to switch to the STILL IMAGE mode.
2. In the STILL IMAGE mode, the camera shows the first image automatically, press the SHUTTER/SELECT button to advance to the next photo, a quick press on the POWER/MODE button will return to the previous photo. Press and hold POWER/MODE button for 3 seconds to switch to Video mode.
3. To Exit and turn off the CAMERA MASK, disconnect the RCA / USB cable from the CAMERA MASK and press and hold the POWER/MODE button until the camera mask turns off. The camera cannot be turned off by pressing the POWER/MODE button when it is still connected to a TV.
4. When the camera connects to the computer and TV at the same time, it will default to the MSDC mode (LCD display shows "USB").

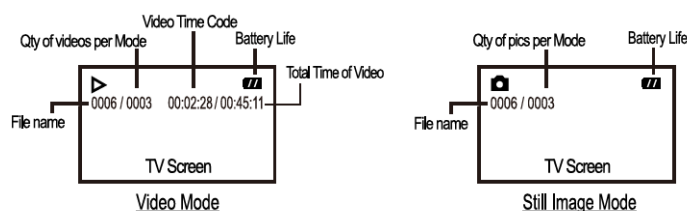

## 7.0 CAMERA TEST INSTRUCTIONS - 4 PARTS

### 7.1 Part One - Taking test images and video:

Before using this product in water and before capturing important digital images and video, be sure to first record a test image and test video to confirm that your camera is set up and ready to go. It is best to move slowly when taking pictures and videos and avoid moving your head side to side as the video will be bouncy and the pictures

ENG-14

will be blurry. Follow the download instructions to complete PART ONE of your test. Liquid Image Co, LLC declines any claim for compensation for recorded contents etc. in case of recording failure due to a camera or card flaw.

In bright sunshine, the LED light may be hard to see. Shade the area over your eye with one hand to see the MODE LIGHT easier.



## 7.2 Part Two - File Size Test

When recording video it is very important that you are already familiar with the file size that your computer can store and playback. If you record a continuous video clip onto a CAMERA MASK's Micro SD/SDHC card, you may not be able to download or play the video file on your computer because of the large file size. Also, your media player may not be able to play large HD Videos.

Please conduct a FILE SIZE TEST before you use your CAMERA MASK to capture important images and video. Test various video file sizes to make sure your computer will be able to store and play the videos that you record. If you have difficulty in playing back video files smoothly, try taking a shorter video. You may also try opening the video file with a different media player as not all media players work the same.

Please read the sample chart below to estimate your file size per minute of recording time.

NOTE: Video file sizes will vary due to the complexity of the scene. The file sizes listed are only estimates.

Approximate Video File Sizes -	TIME (min):	.5	1	10	20
Scuba Series Wide Angle™	SIZE OF FILE:	16MB	33MB	330MB	660MB

NOTE: Depending on the batteries that you use and the size of your Micro SD/SDHC card, you may be able to record a video for an hour or more. It is, however, best to take short videos. This will make transferring files and playing them back easier.

NOTE: The CAMERA MASK records in HD (H.264) file format. The software provided can change the HD video files into another format such as AVI or MPEG files. This may decrease the file size of the output video and affect which media players can play the output videos.

ENG-15

## 7.3 Part Three - Using the CROSS HAIRS (View Finder):

The CROSS HAIRS on the goggles of the CAMERA MASK help you to approximate the camera view. In general, the camera will record a view that is directly in front of you. The view from your eyes will be larger than the image captured.

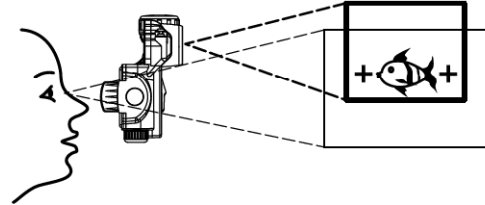

Depending on the position of your eyes in relation to the camera lens and cross hair viewfinders, you may notice that the camera records images which are slightly higher or lower than the view straight in front of you and centered in your crosshairs. This is due to the variance of the location of the eyes in relation to the camera lens. NOTE: Close up images will be higher (above your cross hairs or your view point) because the camera lens is above your eyes.

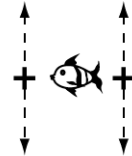

After performing your first camera test, if you notice the top or the bottom of your subject is cut from the image, try looking slightly up or down to perform another test. This will help you determine how best to record your subject while taking an image or video. You may then use the CROSS HAIRS as a reference to determine where your image is framed. For some people, the CROSS HAIRS may rest in the middle of the image. For others, the CROSS HAIRS may be at the top or at the bottom of the image. It is very important to make this determination prior to using the mask for any important images. Practice taking pictures to learn your focal points both close and far.

NOTE: When you first try on the CAMERA MASK, you may barely notice the CROSS HAIRS on the GOGGLE LENSES. The CROSS HAIRS are more noticeable when you wear the mask underwater.

ENG-16

## 7.4 Part Four - Testing the CAMERA MASK in shallow water

It is important to test the CAMERA MASK in a shallow area where you can stand with your head above water.

1. Make sure the water is calm and free of obstacles, including people.
2. Wet hair, and then place the CAMERA MASK over the head. Make sure hair is pulled back so that the seal around the mask is water tight.
3. Test the fit and water tightness around the eyes. Tighten or loosen the head strap if needed.
4. Feel the buttons on the top right side of the mask. Become familiar with the finger placement.
5. Test all the camera modes and notice the MODE LIGHT INDICATOR colors above your right eye.
6. Press and hold the power button until you see the MODE LIGHT INDICATOR disappear. This indicates that the power to the CAMERA MASK is OFF.
7. Remain in shallow water and practice using the buttons on the CAMERA MASK to record images and video until you are comfortable wearing and using the CAMERA MASK while swimming.

CAUTION: For use while snorkeling or scuba diving, be sure you are comfortable with the fit and use of the mask and camera functions prior to use during an excursion. Perform the Camera Test prior to every excursion to check that all parts are functioning.

CAUTION: The CAMERA MASK compartments should only be opened in a safe indoor environment (away from sand and water) to perform necessary operations. NEVER open any compartment that is sealed with screws.

## 8.0 USING THE THIRD PARTY SOFTWARE

ArcSoft® MedialImpression™ PC Version Only

### 8.1 Installation

This CAMERA MASK does not require software to transfer images and video files to a computer. The ArcSoft® software is included to edit your photo and video files.

Follow the instructions on the CD ROM to install the software should you decide to utilize it. Please use the Help Menu, website or any other information they provide if you have questions regarding use of their software.

### 8.2 Photo Editing

The ArcSoft® editing software included has tools to enhance your underwater photos with Color Adjustment, Brightness/Contrast, or an Auto Enhance option. This can help to bring out the colors or details that are lost when the water is dark or murky. The software also allows you to crop, rotate, resize or add text to your image. Complete Instructions are included on the CD.

### 8.3 Video Editing

The ArcSoft® editing software included has tools to edit and adjust your digital video clips. You can trim your videos to select only your favorite moments and then add them together to make a movie out of several different video clips. The software allows you to enhance your underwater video with a Brightness or Contrast adjustment, output your files into different formats or change the size of the file for various uses, such as a website video. In order to play videos on some digital photo frames, you may need to use the software to format and save the video as a MPEG movie. Complete Instructions are included on the CD.

NOTE: The ArcSoft® image and video editing features may change at the discretion of the software company.

## 9.0 CARE AND MAINTENANCE

When you are finished using the CAMERA MASK, always clean and wipe away any water, sand, salt, or other debris before opening or storing. Always clean with FRESH WATER.

### To Clean:

1. Check all three caps for water tight closure before exposing to water.
2. **Always rinse the CAMERA MASK in FRESH WATER** to remove any sand, salt or other debris. Do not use hot water or high pressure which may damage camera. Make sure to depress the buttons while rinsing off with FRESH WATER to clean the buttons of salt and debris. It is best to depress the buttons while the mask is submerged.

ENG-17

Download from [www.Somanuals.com](http://www.Somanuals.com). All Manuals Search And Download.

ENG-18

3. Use a soft dry cloth to thoroughly remove all water. Carefully press around the seams of all compartments to absorb any water left in the cracks.
4. Once the camera is completely dry on the outside, check to make sure that you are also thoroughly dry including your hands, hair, and clothes before opening any compartments. This precaution is necessary so that you will not drip water into or onto the camera.
5. Gently open each compartment. If you find any moisture, sand or debris caught inside the threads of the outer compartment wall, immediately remove them with a cloth or cotton swab.
6. If any moisture or debris has accumulated inside a compartment use a cotton swab to remove it, being careful not to touch the CAMERA MASK electronic components.
7. Before closing any compartment, replace any loose parts. Then inspect and clean the inside of the cap prior to positioning over the open compartment.
8. To keep the O-RINGS working properly, wipe sand, salt, or debris away from the O-RING after each use. After every 3rd or 4th use, apply a thin layer of SILICONE GREASE to the O-RING before closing compartment (see online help for directions). Keep away from Electronic components.
9. Follow the instructions for downloading any files.
10. Store the CAMERA MASK in a dry place away from direct sunlight.
11. Keep the CAMERA MASK at normal room temperatures that do not fluctuate widely. Do not store next to a heater or an air conditioning unit. The extreme temperatures may damage the CAMERA MASK. Exposure to extreme temperatures or temperature fluctuations may cause condensation inside the CAMERA MASK which may damage the device. If you notice condensation, do not use the CAMERA MASK. Set in a dry area, preferably an air conditioned room, or at room temperature until the condensation disappears. Run a camera test to check its function prior to regular use. Do not use a hair dryer.
12. HUMID CLIMATES - Make sure to only open the camera briefly in Humid Climates as moisture in the air may be trapped in the inner compartments if the camera caps are left opened for a period of time. This will result in condensation on the LENS when the CAMERA MASK is submerged in warm water.
13. Safe Operating Temperature: 0 to 40°C (32 to 104°F) / Safe Storage Temperature: -20 to 60°C (-4 to 140°F) / Safe Operating Humidity: 30 to 90% (when no condensation is visible) / Safe Storage Humidity 10 to 90% (when no condensation is visible).

ENG-19

## 10.0 CAMERA WARNINGS AND PRECAUTIONS

**Never touch the camera connection components that are exposed when the MEMORY COMPARTMENT OR BATTERY COMPARTMENT are open. There is a risk of shock if the components in the compartments become wet.**

**If the CAMERA MASK emits a strange noise, smoke or odor, turn off immediately and remove the batteries.**

1. Using the CAMERA MASK in a manner other than what the product use is intended for may result in injury to you, the product, or other persons. Never use the CAMERA MASK for activities other than swimming, snorkeling, or scuba diving.
2. Avoid jolts, drops, collision with other hard objects, or shaking of the CAMERA MASK. These movements may damage the components.
3. Never open the camera body with a screw driver. There is a risk of shock if you touch the camera components.
4. Children under 13 years of age should never wear or operate the CAMERA MASK.
5. Children age 13 to 17 should always have adult supervision with use of this product in and out of water. The CAMERA MASK is not a toy and needs to be treated with the same care as any other underwater digital camera.
6. An adult age 18 or older should always dry the product thoroughly before performing the battery replacement or before performing the transfer of image and video files to a computer.
7. Pay close attention to your surroundings when using the camera. Failure to do so may lead to an accident or injury. If you are not in a safe swimming environment, do not use the camera features.
8. **Only use the CAMERA MASK to the depth rated on the camera and packaging.** Use within the depth parameters. This camera complies with the CAMERA MASK depth rating printed on its packaging and on the camera body for a maximum depth. Using the camera at a depth that exceeds this parameter may expose the interior to water and cause the CAMERA MASK to malfunction.
9. Do not press the buttons of the Underwater Digital Camera Mask with unnecessary force. This may cause damage to the housing.
10. This device contains a specified time limit to water exposure of approximately 60 minutes of consecutive use underwater. Using the camera in conditions that exceed the one hour may expose the interior to water and cause the CAMERA

ENG-20

MASK to malfunction.

11. If the inside of the camera gets wet, immediately turn it off and dispose of the batteries. Then dispose of the CAMERA MASK in accordance with laws for disposing electronics in your country. Using the camera after any internal compartments have become wet may cause a fire or electric shock.
12. If the batteries become wet, there is a risk of fire, shock, shorting the electrical system, or corrosion. Dispose of the batteries immediately in accordance with the battery manufacturer's directions.
13. Do not place on an unstable surface or near the edge of a surface. The camera may fall, resulting in damage to the camera or injury. If the camera has fallen and its body is damaged, turn it off, remove the batteries and dispose of the CAMERA MASK in accordance with laws for disposing electronics. Using the camera after its body has been damaged may cause a fire or electric shock.
14. **Never leave the CAMERA MASK in direct sunlight.** Never leave the Camera Mask in the trunk of a car or in a car on a warm or hot day. Direct sunlight or high temperatures may damage the Camera Mask or cause the housing to burst.
15. Do not use the CAMERA MASK in a location where there is explosive gas, or any other flammable material in the air. Doing so may cause a fire or an explosion.
16. If the camera is not going to be used for a long period of time, remove the batteries from the camera. This will prevent any possible excess heat or leakage of battery fluid that may result in injuries or damage to nearby objects.

## 11.0 MASK WARNINGS AND PRECAUTIONS

1. Do not dive or jump into water while wearing the CAMERA MASK. Jumping or diving into water while wearing the CAMERA MASK could result in injury. Place over your face after entering the water.
2. Remove mask carefully with an upward motion. If you pull straight out it could spring back on your face and injure your eyes.
3. Do not wear the CAMERA MASK while out of the water. The CAMERA MASK is intended for use in water.
4. Do not use the CAMERA MASK if skin is cut, broken or lacerated in any manner. Discontinue use immediately if irritation arises.
5. Do not use the CAMERA MASK under conditions where sudden or high speed impact with the water or hard objects could occur, as sudden impact to the lens or

ENG-21

frame could cause it to break, resulting in serious or permanent injury to the face or eyes.

6. The CAMERA MASK is not suitable for looking directly into the sun. Looking directly at the sun through the tempered glass lenses may damage your eyes.
7. Children should always have adult supervision while swimming or playing in water. Children under 13 years of age should never wear or operate the CAMERA MASK.
8. The CAMERA MASK should only be used by persons who are capable of swimming comfortably and safely while wearing a swimming mask and while operating an underwater camera.
9. Pay close attention to your surroundings including people, marine life, reefs and the water, when using the CAMERA MASK. Failure to do so may lead to an accident or injury.
10. Do not use the Underwater Digital Camera Mask in place of a personal flotation device (life jacket). This is not a lifesaving device.
11. Do not walk or swim with the Underwater Digital Camera Mask around your neck. There is a danger that the neck strap will become twisted or entangled and cause strangulation or another mishap.

## 12.0 BATTERY WARNINGS AND PRECAUTIONS

1. Only batteries of the same or equivalent type as recommended are to be used.
2. Exhausted batteries are to be removed from the CAMERA MASK.
3. Use only appropriate refuse points for environmentally correct disposal of spent batteries.
4. Non-rechargeable batteries are not to be recharged.
5. Batteries are to be inserted with correct polarity.
6. Parental guidance is necessary when installing or replacing batteries.
7. Different types of batteries or new and used batteries are not to be mixed.
8. All batteries are to be replaced at the same time.
9. Do not throw batteries into fire.
10. After use, always switch off the device. Take out batteries to store the device.
11. The supply terminals are not to be short-circuited.
12. Do not drop, hit, or submit the battery to strong shocks.
13. Do not allow the battery to come into contact with fresh or salt water, or allow

ENG-22

the terminals to become wet.

14. If the battery is leaking and the battery fluid gets on your skin or clothing, immediately rinse with clean water and seek emergency care.
15. Rechargeable batteries are to be removed from the product before being charged.
16. Rechargeable batteries are only to be charged under adult supervision.

### 13.0 COMMONLY ASKED QUESTIONS AND TROUBLESHOOTING

1. How deep can my CAMERA MASK go underwater? Your CAMERA MASK is rated to a specific depth stated on its packaging and warranty as well as on the CAMERA MASK itself. Some CAMERA MASKS may be rated to a deeper level than others due to parts and testing procedures indicated at the time of production for that unit. Taking the CAMERA MASK to a deeper level may cause damage and will void any warranty.

2. When I take photos they are sometimes dark or blurry. The clarity of the water you are in and the lighting conditions will affect your images. Oceans, lakes or pools can vary widely in clarity and that clarity often decreases as you descend in the water. Test the camera's photo ability in several other conditions such as clear water near the surface and test above water in several daylight conditions to assess the camera's function. Dirt, salt, or fingerprints on the lens covering may also blur your photos. Also, you may experience water drops on the front glass lens when you are above the water which will cause blurry pictures. Gently wipe with a soft, dry cloth to clean. This camera was developed for outdoor use in daylight. Images or video recorded indoors may not have a desirable quality. You may also try using photo editing software to brighten or enhance the colors in your images and video.

3. When I take photos I cut off the top or bottom of my subject. Your CAMERA MASK has cross hairs on the goggles; use them as a reference to align your photos. The location of the cross hairs is only a reference guide. See 7.3 Camera Test Instructions PART 3 - USING THE CROSS HAIRS (VIEW FINDER).

4. My camera has stopped recording videos or images. If your CAMERA MASK has stopped recording images or video, check to see if the memory is full. You will see the word FULL display on the LCD screen. Also check to see if your battery is

ENG-23

empty. Replace batteries if needed.

5. My face or head does not fit the CAMERA MASK. Try adjusting the head strap. The SILICONE SKIRT is made to fit a variety of face shapes and sizes; however it may not accommodate all face shapes and sizes. Model 320 is a mid-size skirt. Model 321 is a large size skirt.

6. My goggles fill up with water. First try adjusting the HEAD STRAP. Facial hair can cause the mask to leak. Try using a petroleum jelly on facial hair to minimize leaking.

7. My goggles fog up. You may purchase an Anti-Fog product to place on the GOGGLE LENSES. For the best results, do not take your mask off after putting in the anti-fog product on the lenses as water may wash out the fluid and cause the mask to fog again.

8. My battery power runs out quickly. Not all batteries are made equally. We suggest using Energizer® Lithium batteries for the best performance of this camera. Make sure you only insert new batteries that have been properly stored to maintain their full usage. Do not mix different types of batteries.

9. My CAMERA MASK is no longer working. Any large changes in temperature, exposure to extreme temperatures or sudden jolts, including dropping your CAMERA MASK may damage the camera components. If you have not dropped your camera or caused damage through any physical shaking or colliding of the camera with a hard object, or if you have not caused exposure to extreme temperatures or temperature fluctuations, there may be an issue of water leakage into one of the compartments. Thoroughly dry the CAMERA MASK, checking for any loose parts, including the 3 caps. After inspection, carefully open and check inside each of the compartments for any trace amounts of water or debris. DO NOT OPEN THE BODY OF THE CAMERA MASK. Be careful not to touch any camera components inside the MEMORY COMPARTMENT OR BATTERY COMPARTMENT. If no water or debris were found in any of the compartments, check to see if the battery power is out by replacing the batteries with four new batteries. Go to the online help for troubleshooting solutions.

10. My CAMERA MASK is ON, but not functioning. If your CAMERA MASK has stopped recording images or video, check to see if the memory is full. You will see the word FULL display on the LCD screen. Also check to see if your battery is empty or low. If the camera is "Frozen" or not functioning while on, there may be an issue

ENG-24

with the battery. Move to a clean and dry environment and completely clean and dry your CAMERA MASK. Try removing the batteries and returning them to the compartment. Then turn the camera back on to check for function. If it is still not working, replace the batteries with NEW ones and check for function.

For more trouble shooting, visit our website's help section [www.LiquidImageCo.com](http://www.LiquidImageCo.com) or email our CUSTOMER SUPPORT at [support@LiquidImageCo.com](mailto:support@LiquidImageCo.com).

### 14.0 ACCESSORIES, FIRMWARE, AND SOFTWARE

The CAMERA MASK ships with third party software and may ship with other accessories. It is not necessary to use these products with the CAMERA MASK. You may decide not to install or use any software or accessories supplied with the CAMERA MASK. The Software is for PC only. It does not work with a MAC.

Follow the instructions provided by the manufacturer of the software or accessories. Please refer to their guides, help phone lines, email or websites for troubleshooting with their products. Liquid Image Co, LLC declines any claim for compensation for any damages resulting from any third party software or accessories supplied with the CAMERA MASK.

#### FIRMWARE (F/W) upgrade method:

In shutdown mode, first press and hold the SHUTTER / SELECT button, then press the POWER / MODE button to turn on the camera, release these two buttons after hearing a BEEP sound. If a micro SD card with firmware.bin file in the root directory is inserted, the F/W will be updated. If the SD card does not have the firmware.bin file, the camera will automatically return to video mode. Note: The LCD display will show "UP" during the upgrade process, when the upgrade is finished, the LCD display will turn off automatically.

LIMITED WARRANTY: See limited warranty form included with this product.

ArcSoft®, MediaImpression™ are the trademarks of ArcSoft®.

Energizer® is the trademark of Energizer. All other company and product names are registered trademarks and trademarks of their respective owners.

Underwater Digital Camera Mask, Camera Mask and Scuba Series Wide Angle are the Trademarks of Liquid Image Co, LLC.

US and Foreign Patents Pending

Colors and style may vary from picture shown  
Made in China

ENG-25

**Warning:** TO PREVENT THE RISK OF FIRE OR ELECTRIC SHOCK, DO NOT EXPOSE THE INNER ELECTRONICS TO RAIN OR MOISTURE.

### FOR AMERICAN USERS

The following advisory is included in accordance with the laws of the state of California (USA)

#### WARNING:

This product contains chemicals, including lead on the internal electronic board, known in the State of California to cause cancer, birth defects or other reproductive harm. **Wash hands after handling.**

Warning: Changes or modifications to this unit not expressly approved by the party responsible for compliance could void the user's authority to operate the equipment.

NOTE: This equipment has been tested and found to comply with the limits for a Class B digital device, pursuant to Part 15 of the FCC Rules. These limits are designed to provide reasonable protection against harmful interference in a residential installation. This equipment generates, uses and can radiate radio frequency energy and, if not installed and used in accordance with the instructions, may cause harmful interference to radio communications.

However, there is no guarantee that interference will not occur in a particular installation. If this equipment does cause harmful interference to radio or television reception, which can be determined by turning the equipment off and on, the user is encouraged to try to correct the interference by one or more of the following measures:

- \* Reorient or relocate the receiving antenna.
- \* Increase the separation between the equipment and receiver.
- \* Connect the equipment into an outlet on a circuit different from that to which the receiver is connected.
- \* Consult the dealer or an experienced radio/TV technician for help.

Shielded cables must be used with this unit to ensure compliance with the Class B FCC limits.

### FOR CANADIAN USERS

This Class B digital apparatus complies with Canadian ICES-003.

ENG-26

Declaration of Conformity

This device complies with Part 15 of the FCC Rules.

Operation is subject to the following two conditions:

- (1) this device may not cause harmful interference, and
- (2) this device must accept any interference received, including interference that may cause undesired operation.

**Notes:**

In the blank space below, write down your focus point when using the cross hairs. This will insure that you remember how to align and frame objects in front of you with respect to your eyes and the cross hairs.

ENG-27



**LIQUID IMAGE**®

Liquid Image Co, LLC  
7909 Walerga Rd., Suite 112-206  
Antelope, CA 95843, USA  
Company Phone: 916-721-4848  
[www.LiquidimageCo.com](http://www.LiquidimageCo.com)



**RoHS**



Printed in China



## Free Manuals Download Website

<http://myh66.com>

<http://usermanuals.us>

<http://www.somanuals.com>

<http://www.4manuals.cc>

<http://www.manual-lib.com>

<http://www.404manual.com>

<http://www.luxmanual.com>

<http://aubethermostatmanual.com>

Golf course search by state

<http://golfingnear.com>

Email search by domain

<http://emailbydomain.com>

Auto manuals search

<http://auto.somanuals.com>

TV manuals search

<http://tv.somanuals.com>