



Portable FM System Design Guide and Manual

Don't miss a single sound.





Dear Valued Customer,

Thank you for choosing Listen! All of us at Listen are dedicated to providing you with the highest quality products available. We take great pride in their outstanding performance because we care that you are completely satisfied. That's why we independently certify them to the highest quality standards and back them with a limited lifetime guarantee. We stand ready to answer any questions you might have during installation or in the operation of our products. Should you experience any problems whatsoever with your Listen products, we are ready to help you in any way we can with prompt, efficient customer care. Because at Listen, it's all about you! And should you have any comments on how we might improve our products or our service, we're here to listen.

Here's how to reach us:

+1.801.233.8992
+1.800.330.0891 North America
+1.801.233.8995 Fax
support@listentech.com
www.listentech.com

Listen Technologies GmbH
Jasminstr. 16
905 22 Oberasbach, Germany
+49 911 955159 0 Tel
+49 911 955159 40 Fax
www.listentech.de
info@listentech.de

Thank you and enjoy your listening experience!

Best regards,
Russell Gentner and the Listen Team

Lifetime Warranty – the best in the business!

Listen's full-time technical support is passionate about what they do and you can depend on them to solve any equipment issues with confidence. In the few instances where repairs were needed, 99% of all clients indicated that they were happy with repair turn-around-times and 85% of the time, clients were without their product for less than 10 days!

Overall client satisfaction of working with Listen was rated 4.8 out of 5.

The Word Around Listen

"Please continue with your excellent attitude toward customer satisfaction. You guys are great!"

"I've never had such good service from any company. Keep up the good work!"

"You stand behind your product wonderfully."

Portable FM Table of Contents

Design Guide	
FM Technology Overview	5
System Overview	6
Key Concepts in Designing an FM System	8
Notes	10

LT-700-863 Portable FM Transmitter	
Specifications	17
Block Diagram	18
Quick Reference	19
Setup Instructions	20
Operating Instructions	23
Programming Instructions	25
Accessories	28
Notes	29

LR-400/500-863 FM Receivers	
Specifications	37
Block Diagram	39
Quick Reference	40
Setup Instructions	42
Operating Instructions	45
Programming Instructions (LR-500 only)	51
Accessories	52
Notes	53

Supplementary Information	
Frequency Chart	61
Battery Charging Information	62
Troubleshooting	63
Frequently Asked Questions	65
Compliance, Warranty and Contact Information	67
Notes	68

863.050

863.200

863.400

863.5



60.96 m (200 ft)

Don't miss a single sound.

Portable FM Design Guide Table of Contents

FM Technology Overview	5
System Overview	6
Key Concepts in Designing an FM System	8
Notes	10

Frequency Modulation (FM) Technology Overview

Frequency modulation (FM) is a means of transmitting audio using electromagnetic waves. This same technology is used by local FM radio stations to broadcast voice and music. FM signals can travel through most barriers – walls, floors, and ceilings. The distance a signal travels has many different variables such as Radio Frequency (RF) output power, the type and placement of the antenna and the broadcasted frequency. This section of the manual will help you design a system that will get the best range with the least amount of interference.



When designing an FM system it is important to keep the following in mind:

• **Multipath**

Multipath interference is a form of RF interference that occurs when radio signals have more than one path between the receiver and the transmitter causing the two RF signals to add out of phase. This could occur in areas with RF-reflective surfaces, such as furniture, walls, or floors. The result of multipath is the receiver audio coming in and out of squelch when the receiver is moved. Portable applications are much more susceptible to multipath than those that are stationary. Multipath distortion is often worse as the distance between transmitter and receiver increases (RF power decreases). Multipath can decrease the audio quality of the transmission (refer to page 9 for strategies on eliminating multipath).

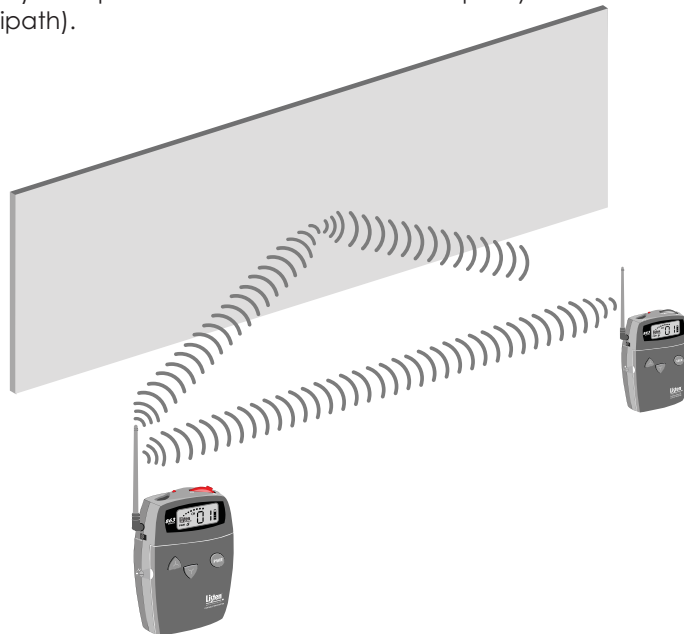

• **Antenna Positioning**

For full RF functionality of the portable system, the antenna on both the LT-700 transmitter and receiver (LR-400/500) must be in the upright position (shown below).



System Overview

There are three main parts to a Portable FM System – Input source, transmitter, and receiver.

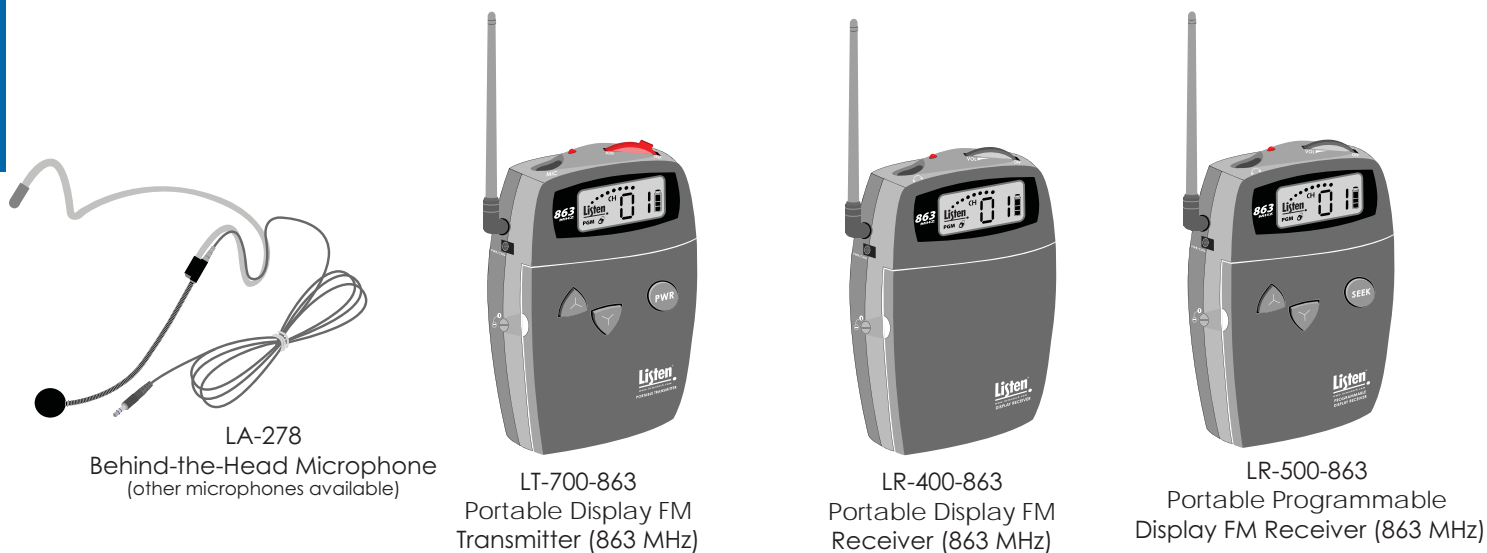

Input Source

A microphone is the most common input source for the LT-700 transmitter, although, the LT-700 can transmit two audio inputs at once on one transmission channel. With the use of the LA-263 both the inputs will be mixed. Thus, a person can use a line input source and mic source.

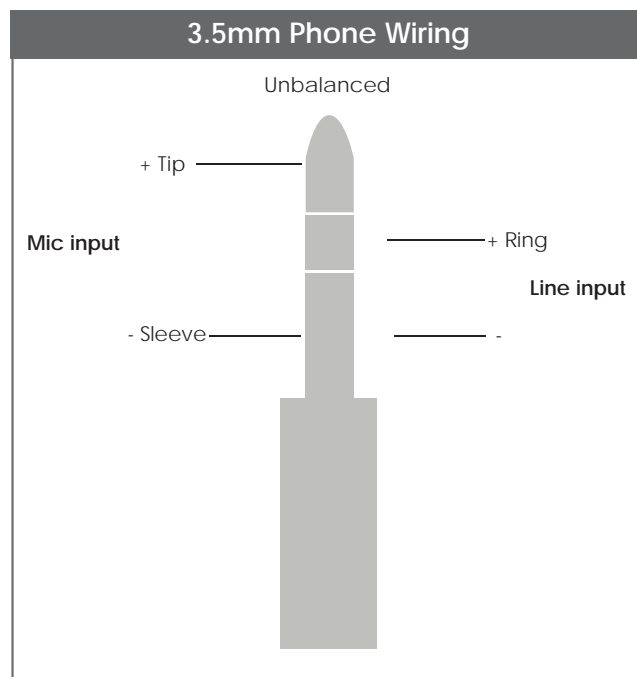
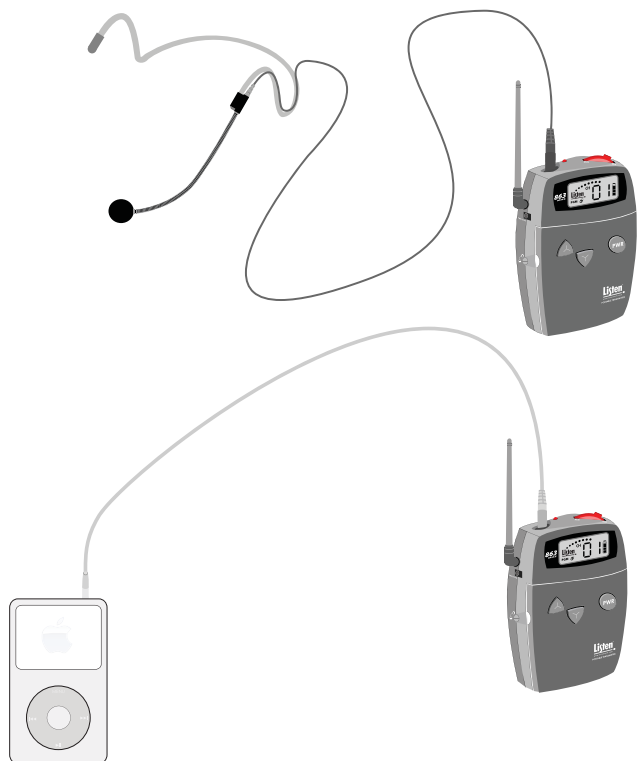

System Overview

Transmitter

The LT-700 modulates the audio on an FM carrier and transmits the signal via an antenna on the unit.



LT-700-863
Portable Display FM
Transmitter (863 MHz)

Receivers

Listen offers two different portable receivers.



LR-400-863
Portable Display FM
Receiver (863 MHz)



LR-500-863
Portable Programmable
Display FM Receiver (863 MHz)

Key concepts in designing a portable FM system

Channel Selection

Use this section of the guide to choose the channel settings for the transmitter and receivers.

- The goal is to find a transmission channel(s) that is free from interference. Interference originates from other transmitters and from other equipment (such as a computer).
- Listen products offer 17 different channels to choose from. This increases the chance you'll find an interference free channel.
- The best way to check for interference is to use the "SEEK" button on the receiver. Be sure all Listen transmitters have been turned off if there is interference, the receiver will find these channels. If the receiver finds a frequency in use, do not use this channel.
- In general, most of the channels will be free from interference.
- Interference can be overcome by maximizing the transmission power and by using the receivers close to the transmitting antenna.
- If more than one channel is in use, space the channels further from each other. Use the Listen frequency chart on page 61 to determine the appropriate channels.

*EXAMPLE: 2 channel system use channels 01 & 11
3 channel system use channels 01, 06 & 11*

Range

The range of a portable transmission will vary from one application to another. There are many different obstructions that could minimize the range. In most applications, the range will be approximately as shown below (P= Power Level - refer to page 26 for programming power levels of the LT-700).

P1 – 30 meters (100 ft)

P2 – 46 meters (150 ft)

P3 – 61 meters (200 ft)

Range varies depending on environment.

Maximizing Range

Here are some tips to maximize the transmission range:

- Eliminate or minimize obstructions between the transmitter and receivers.
- Minimize the distance between the transmitter and receivers.
- Move transmitter and receivers away from metal objects.
- Orient both transmitting and receiving antennas vertically.

Key concepts in designing a portable FM system

Eliminating Multipath

As mentioned on page 5, multipath can occur with portable RF systems. The audio quality of the transmission can decrease with the occurrence of multipath. Here are a few potential improvements that can help if multipath takes place:

Squelch

Squelching the receiver will mute the audio output when the signal from the transmitter is turned off or the signal is too weak to be received. Without squelch you would hear radio noise in your earphone with no RF signal present. "Tightening" the squelch will turn the receiver off if it is chattering because of multipath (refer to page 48 for programming squelch). Keep in mind, "tightening" squelch will limit the range between transmitter and Receiver.

Transmitter power level

The RF power level can be adjusted on the LT-700 (refer to page 26 for programming LT-700 power levels). The lower the power setting, the less range the transmitter will broadcast. Decreasing the broadcast range will force the receivers to remain closer to the transmitter. To maintain an RF signal, the higher power settings will increase range between transmitter and receiver thus introducing a higher probability of multipath.

Multiple Portable Systems

In some applications, there will be more than one RF transmission in the same general vicinity. Intermodulation interference can occur if the transmission frequencies are too close together. Here are some ways to eliminate the chance of RF interference:

Squelch

Much like a multipath situation, "tightening" the squelch on the receiver will mute the audio output when the signal is too weak to be received. Tightening the squelch will help with force the receiver to squelch when signal becomes too weak. (refer to page 48 for programming squelch).

Transmitter power level

As mentioned above, the RF power level can be adjusted on the LT-700 (refer to page 26 for programming LT-700 power levels). The lower the power setting, the less range the transmitter will broadcast. Lowering the power could help decrease the amount of interference if there are many frequencies being used in the vicinity.

Spacing of channels

Use a Listen frequency chart (on page 61) to determine the channels frequency and space the number of channels further from each other.

DX/Local

The receiver can be adjusted to receive only the strongest signals (refer to page 50 for DX/Local information). A DX signal will be less sensitive because distance is the ultimate goal. For applications where you want to minimize the distance, local mode will only search for strong signals. Local mode is much more sensitive than DX.

Notes

Notes



Portable FM 863 MHz

863.050

863.200

863.400

863.5



LT-700-863 Portable FM Display Transmitter

Don't miss a single sound.

LT-700 User's Manual Table of Contents

Specifications	17
Block Diagram	18
Quick Reference	19
Setup Instructions	20
Operating Instructions	23
Programming Instructions	25
Accessories	28
Notes	29

LT-700 Package Contents

- LT-700-863
- Quick Reference Card
- Warranty Card
- FM Manual Card



LT-700-863
Portable Display FM
Transmitter (86.3 MHz)

Listen Configurations

- LT-700-863

LT-700-863 Specifications

Architectural Specification

The LT-700-863 portable FM Transmitter shall be capable of broadcasting on 17 channels. Channel tuning shall be capable of being locked. The transmitter shall have a SNR of 70 db or greater. The output power shall be adjustable to quarter, half or full. The device shall have an audio frequency response of 50 Hz to 15 kHz, +/-3 dB. The device shall incorporate a microphone sensitivity switch. The device shall incorporate a mute switch. The unit shall utilize two 2 AA batteries. The battery door shall be capable of being mechanically locked. The device shall incorporate an LCD display that indicates battery level, channel, channel lock, low battery, battery charging, programming, and RF signal strength. The portable transmitter shall incorporate automatic battery charging circuitry for recharging of NiMH batteries. The Listen LT-700-863 is specified.

	Specifications	LT-700-863
RF	RF Frequency Range	863.050 - 864.950 MHz
	Number of Channels	17 wide band
	Frequency Accuracy	± .005% stability 32 to 122° (0 to 50° C)
	Transmitter Stability	50 PPM
	Transmission Range	0 ft. (0 m) to 200 ft. (60.9 m)
	Output Power	10 mW maximum (adjustable)
	Antenna	Uses microphone cable
	Antenna Connector	3.5 mm connector
	Compliance	CE, ETSI, RoHS
Audio	System Frequency Response	50 Hz - 15 kHz (± 3 dB)
	System Signal to Noise Ratio	70 dB (A-Weighted)
	System Distortion	<2% total harmonic distortion (THD) at 80% deviation
	Microphone Input	Unbalanced, tip of 3.5mm connector, -20 dBu nominal, -30 dBu maximum, impedance 21 ohms
	Microphone Sensitivity	Three position switch: high, middle, and low; 6 dB increments
	Line Input	Unbalanced, ring of 3.5mm connector, -10 dBu nominal input level, -3 dBu maximum, impedance 10K ohms
	Microphone Power	3 VDC Bias
Controls	User Controls	Power, mute, channel UP/DOWN
	Set-up Controls (battery compartment)	Mic sensitivity, NiMH/alkaline battery, SQ enable/disable
	Programming	Channel Lock out, Channel lock
Indicators	LED	Red, illuminated when unit is on. Flashes when batteries are low, or to indicate charging. Flashes when muted
	Display	Channel Designation, lock status, signal strength indication, battery life, RF Power
Power	Battery Type	Two AA batteries, alkaline or NiMH
	Battery Life (Listen batteries)	15 hours alkaline (LA-361), 8 hours NiMH rechargeable (LA-362)
	Battery Charging (NiMH only)	Fully automatic, 13 hours
Physical	Dimensions (H x W x D)	3.00 x 1.00 x 5.00 in. (7.6 x 2.5 x 13.0 cm)
	Color	Dark Grey with white silk screening
	Unit Weight	3.9 oz (111 g)
	Unit Weight with batteries	5.8 oz (164 g)
	Shipping Weight	1.0 lbs. (0.45 kg)
	Door	Manually Lockable. Up, down, and power buttons through door. Other controls behind door (see controls)
Environmental	Temperature - Operation	14 to 104° F (-10 to 40° C)
	Temperature - Storage	-4 to 122° F (-20 to 50° C)
	Humidity	0 to 95% relative humidity, non-condensing

Specifications are subject to change without notification

LT-700 Block Diagram

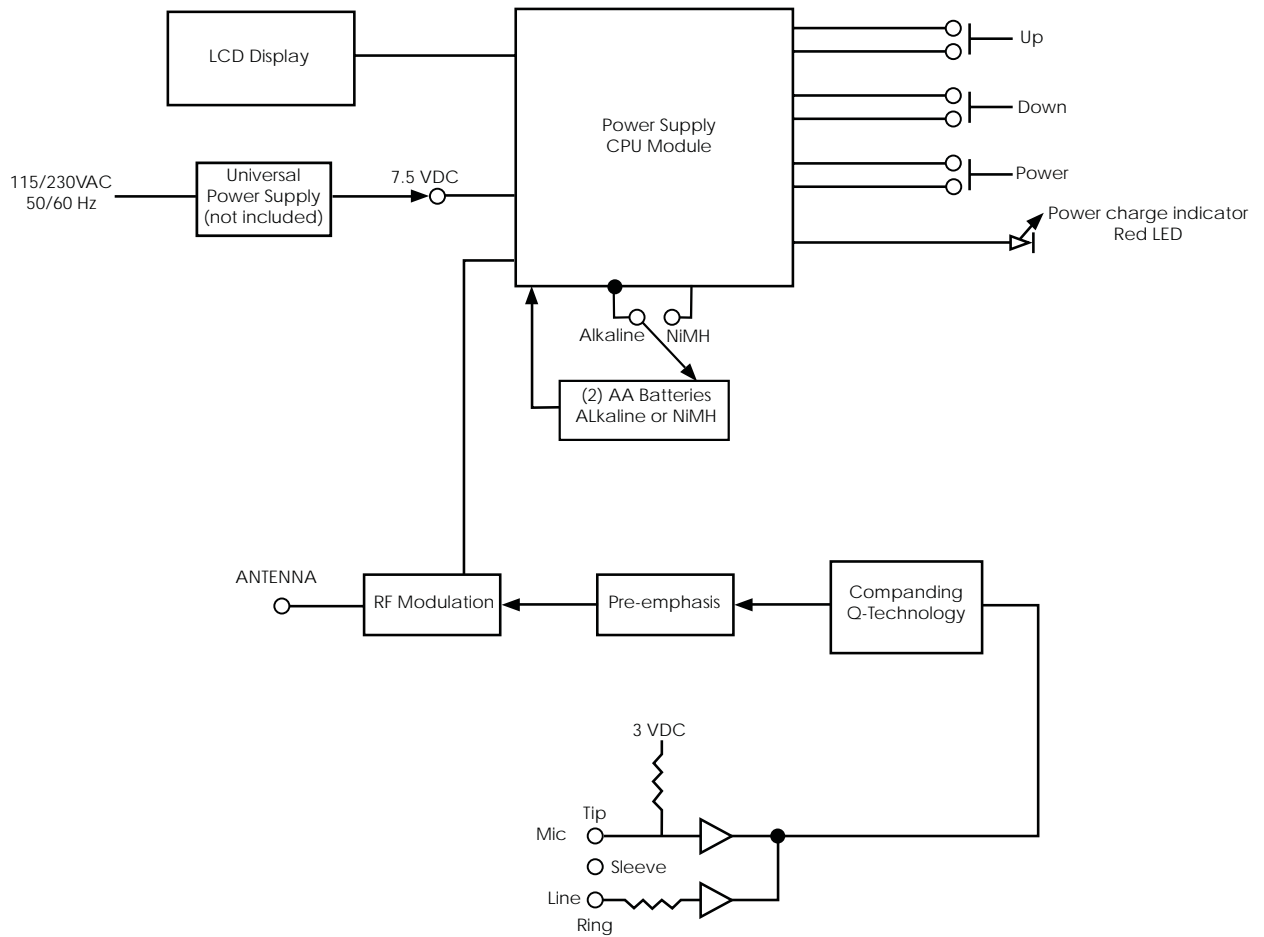

LT-700 Quick Reference

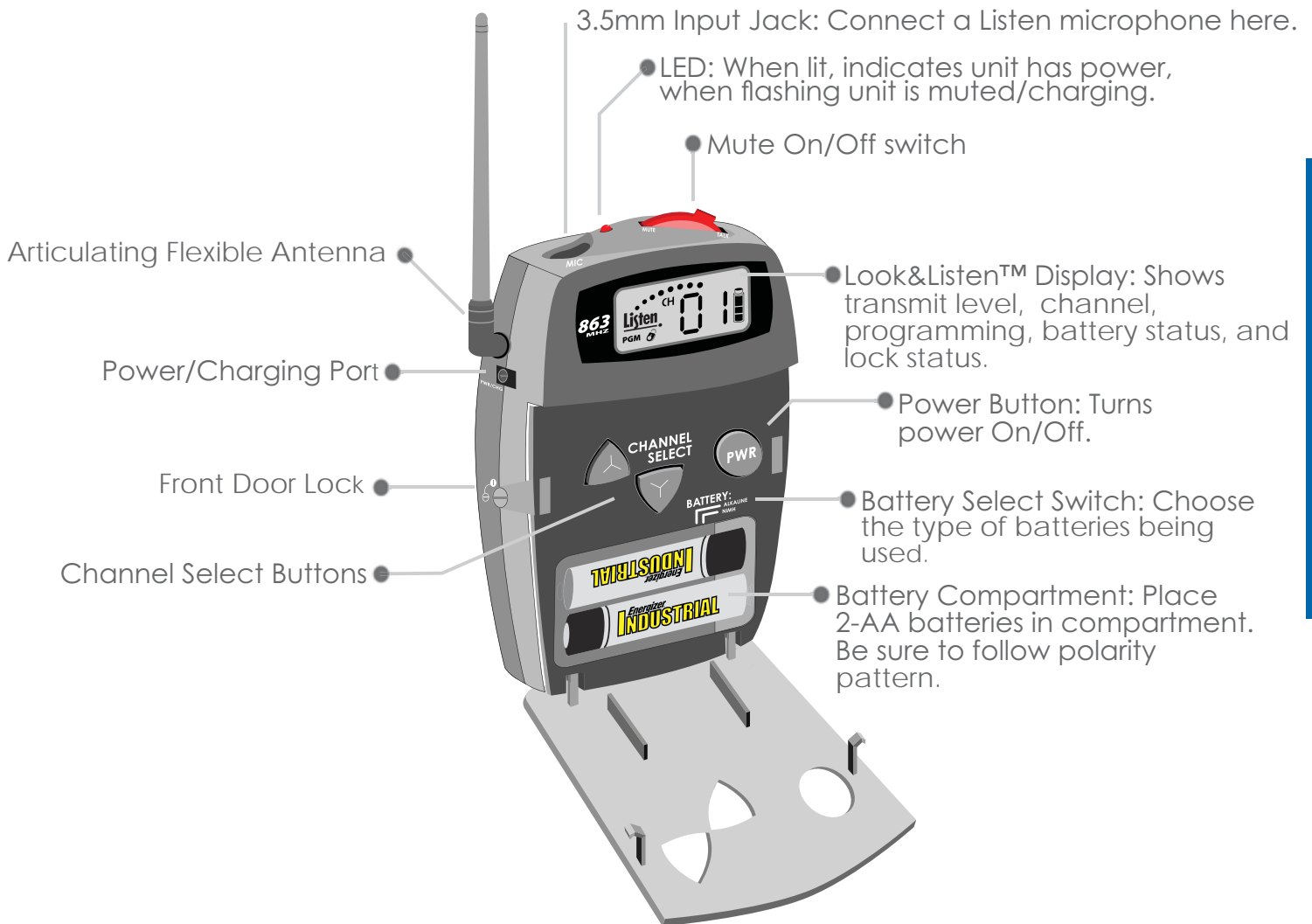

LT-700

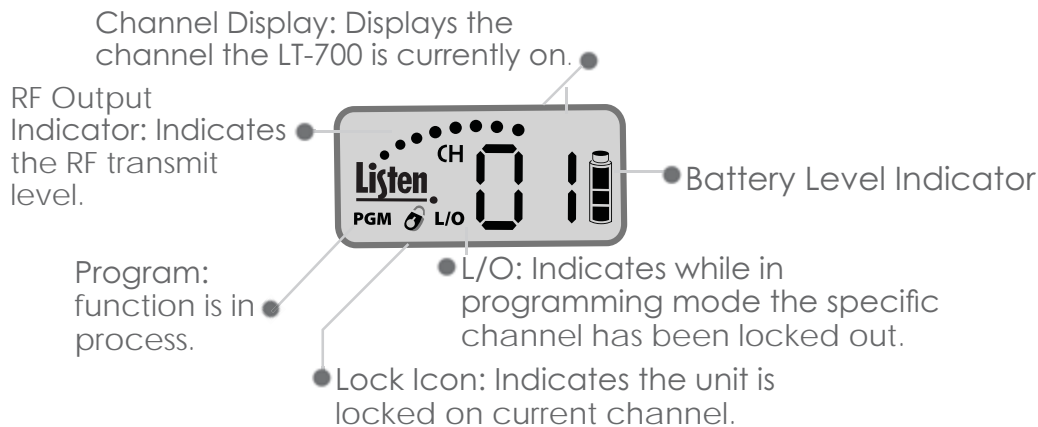

LT-700 Setup Instructions

1 Unpack the Product

Remove outer packaging and plastic cover. Inspect for physical damage. If damage is apparent, please contact the dealer from which the product was purchased or Listen Technologies Corporation technical support for assistance (refer to page 67 for contact information).

2 Open the front access door

If locked, use a pocketknife or small screwdriver to unlock the door locks on both sides of the unit. To unlock the door, rotate the lock ¼ turn counterclockwise. Grip the two tabs with your thumb and index finger and pull the door downward. DO NOT place batteries in the unit at this time.

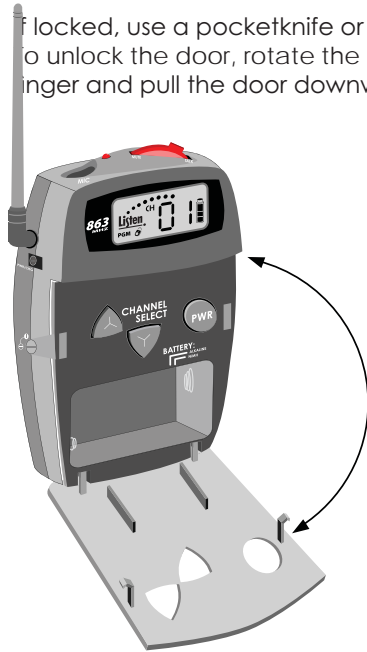

3 Select Battery Type

Two types of batteries may be used: NiMH or Alkaline. The unit is shipped with the switch in the Alkaline position. Use a pen or small screwdriver to select the battery type.

WARNING: Do not place the BATTERY switch in the NiMH position if you are not using Nickel Metal Hydride Batteries. The NiMH position will attempt to charge any batteries in the unit, even if they are not the proper type. Charging non-Nickel Metal Hydride (NiMH) batteries will result in physical harm, destruction of property and/or fire.

CAUTION: If you are using any battery type other than rechargeable Nickel Metal Hydride (NiMH) batteries, make sure the BATTERY selection switch is in the alkaline position.

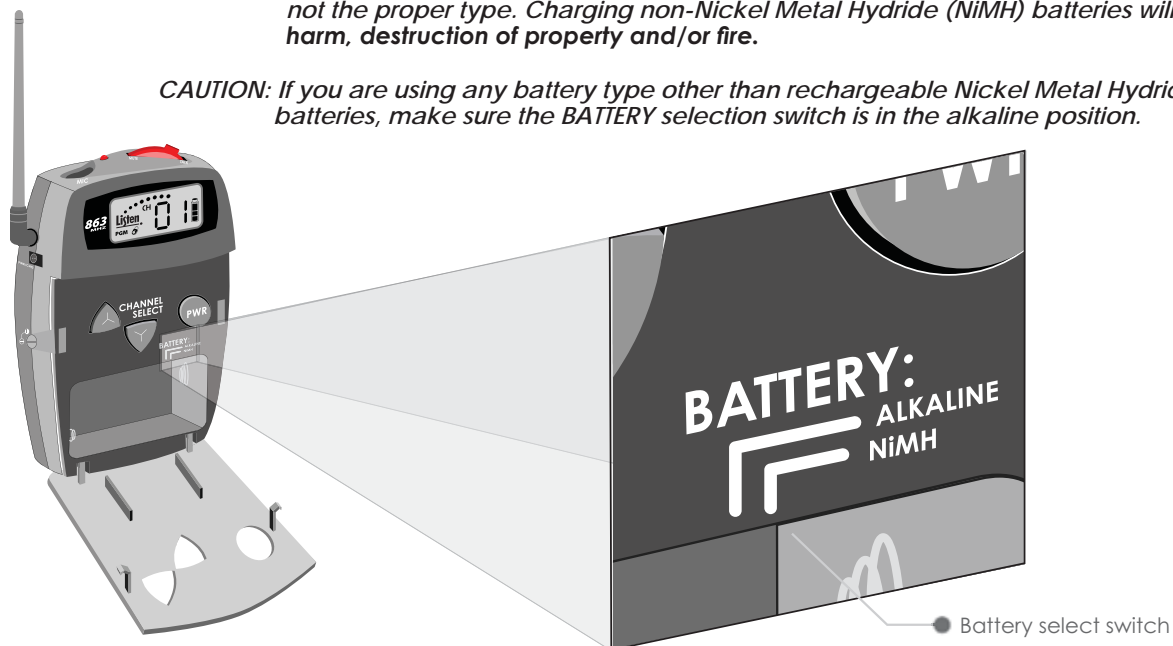

LT-700 Setup Instructions

4 Set Mic Sensitivity Switch

The microphone sensitivity switch is located inside the battery compartment, to the left of the BATTERY selection switch. The LT-700 is shipped with this switch in the center (MED) position. Listen recommends the following settings for our microphones. If you are using a microphone from another vendor, you may need to experiment with different settings.

Part # Description Setting

LA-261	Lavalier Microphone	
LA-262	Over-the-Head Microphone	
LA-272	Over-the-Head Microphone w/Earphone	
LA-274	Hand Held Microphone	
LA-276	Collar Microphone	
LA-277	Behind-the-Head Microphone	
LA-278	Conference Microphone	

5 Place Batteries in Unit

Place two AA batteries in the compartment, making note of the battery polarity shown in the battery compartment, and again verifying that the BATTERY SELECT switch is in the correct position for the batteries you are using. (Alkaline should be selected for all battery types other than NiMH).

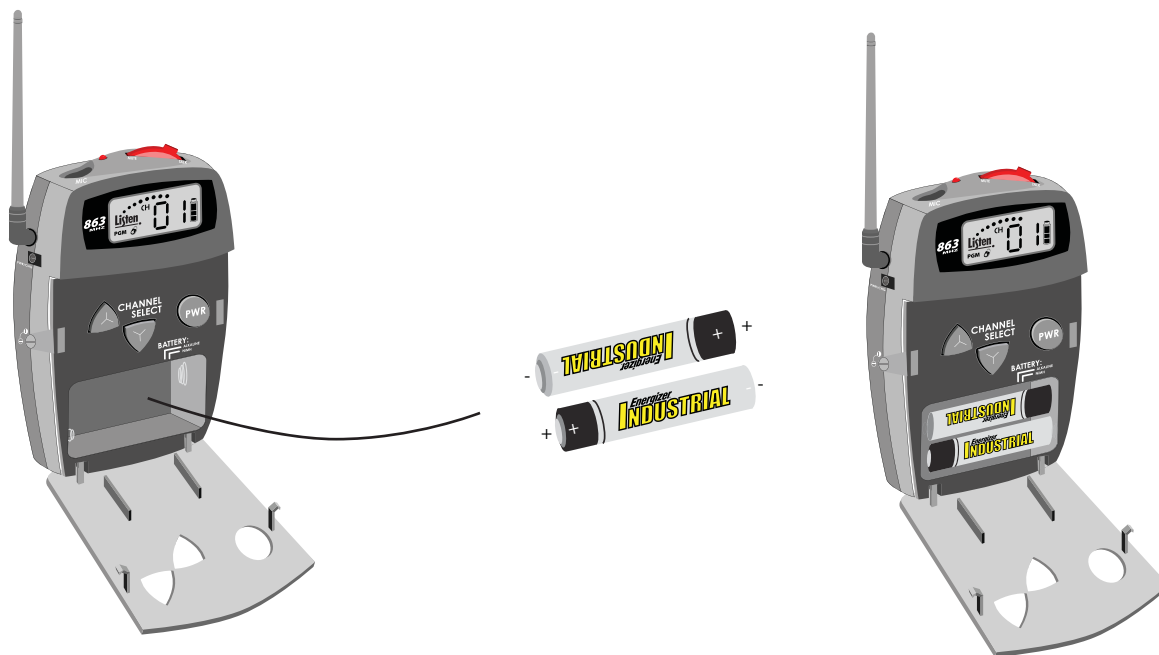

LT-700 Setup Instructions

6 Connect the Microphone

The microphone jack is located on top of the unit.

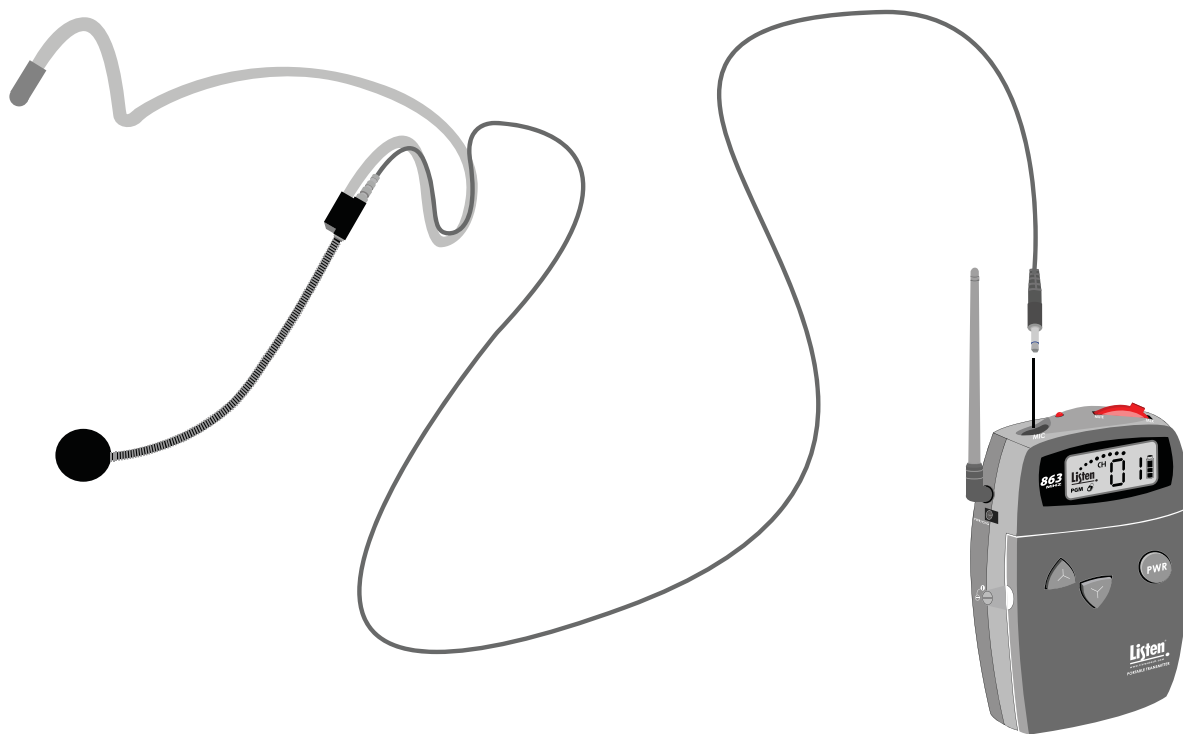

7 Connect the Line Input Cable (Optional)

This cable allows you to connect a TV, CD player or other equipment to the LT-700. To do this, you must order the Listen LA-263 Line Input Cable (not included with your unit). This cable allows you to connect both a microphone and line input to the jack on top of the LT-700. See the diagram below for connection information. You can use the microphone and the line input at the same time.

NOTE: The MUTE switch mutes only the microphone; the line source will continue transmitting when the switch is in the MUTE position.

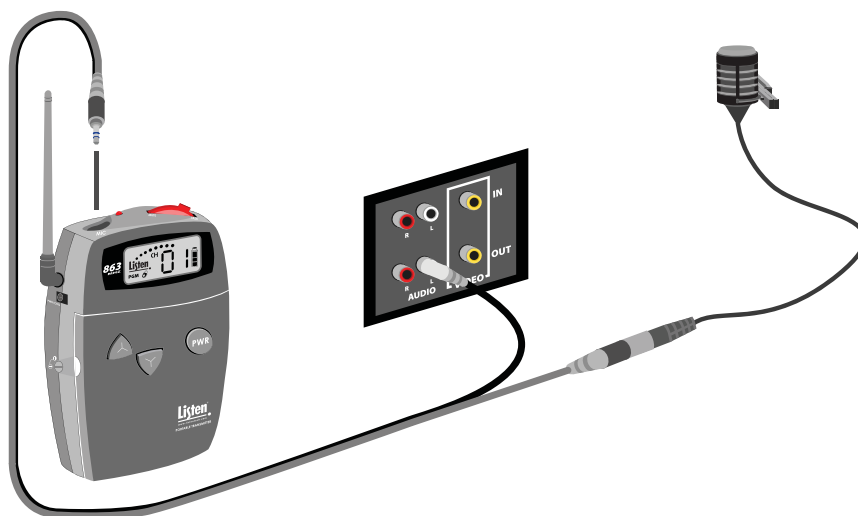

LT-700 Operating Instructions

1 Turn Unit On

1A Power On/Off Button

When you press the power button, the unit turns on. The LED on top of the unit will be illuminated and the LCD display will be visible.

2 Antenna Positioning

Raise the antenna to the upright position. When the antenna is fully upright, it will click into position.

NOTE: Be aware that the transmission range could decrease if the antenna is not in an upright position.



3 Select the channel for transmitting

863 MHz operates on 17 wide band channels. Channels are displayed numerically (i.e. 01-17) (refer to Channel Selection in design guide page 8) for guidelines on choosing an interference free channel.

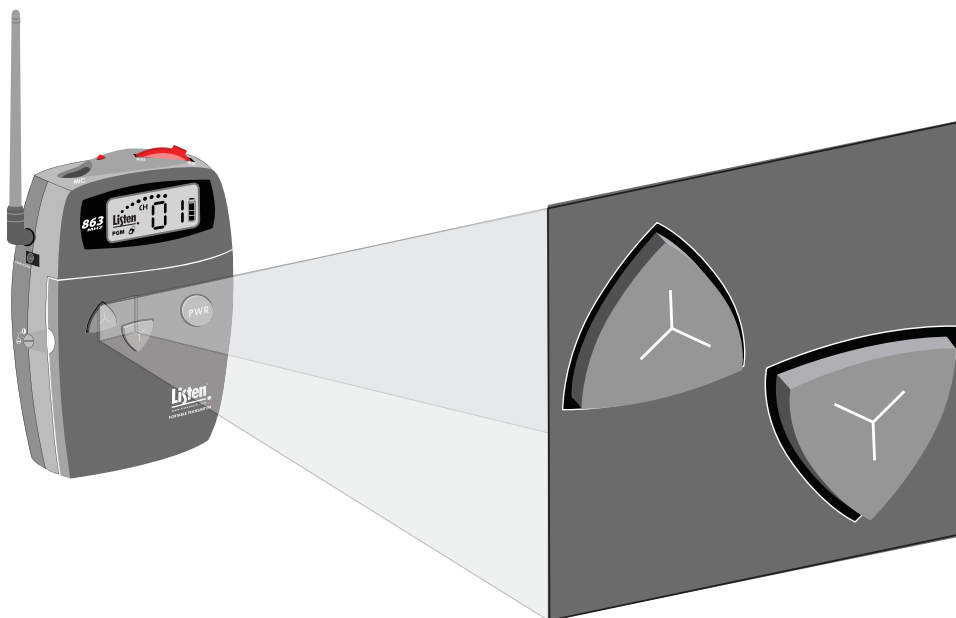

LT-700 Operating Instructions

7 Using the MUTE / TALK switch

Slide the switch to the mute position and the microphone audio is muted. When the microphone audio is muted, the LED on top of the unit flashes rapidly. Slide the switch back to the talk position and the microphone audio will return to the transmission. If you are using the line level input, it will not be affected by the mute/talk switch.



Locking the Transmitter on One Channel

The unit can be electronically locked on one channel so that it will not change channels even if the channel select buttons are pressed. It is recommended to lock the transmitter on a channel that is being used in a single channel system or when multiple systems are in the same area.

1 To lock on a channel

1A Press and hold the DOWN button for 5 seconds

Press and hold the DOWN button for 5 seconds to lock the transmitter onto the desired channel. Press and hold the button again to unlock.

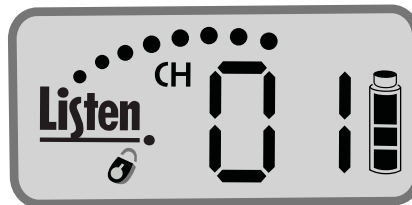

NOTE: On the LT-700, when the channel is locked, a lock icon will appear underneath "Listen" on the display.

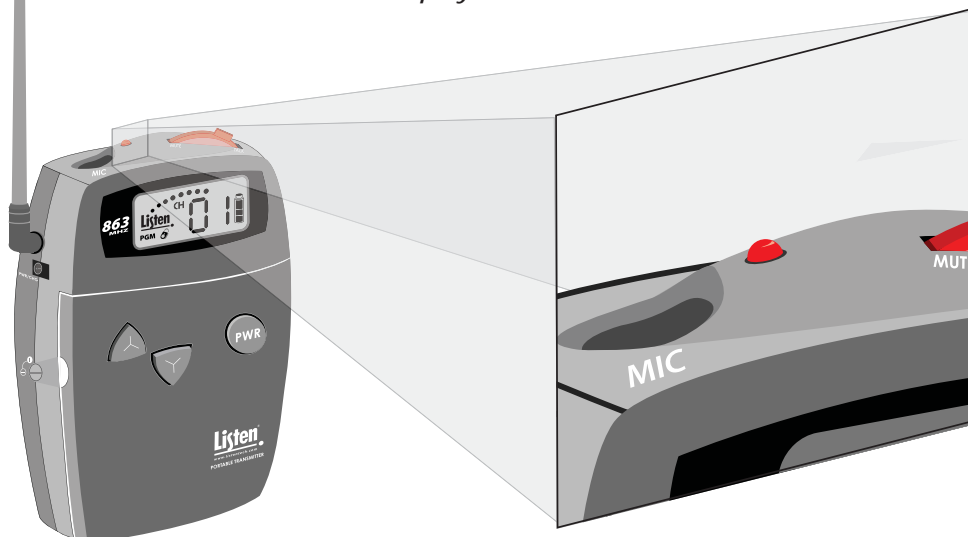

LT-700 Programming Instructions

Program Mode Overview

The LT-700 can be programmed to transmit on a limited number of channels. For applications where users are required to select a channel (such as classrooms or language interpretation application), and you don't want them to have to scroll through all of the available channels, this feature is ideal. The LT-700 can also be changed from high to low power levels. Adjusting the power settings allows you to set the range of the transmission.

Entering Program Mode

- 1 While the unit is ON, press and hold the channel down and up buttons simultaneously for 3 seconds.

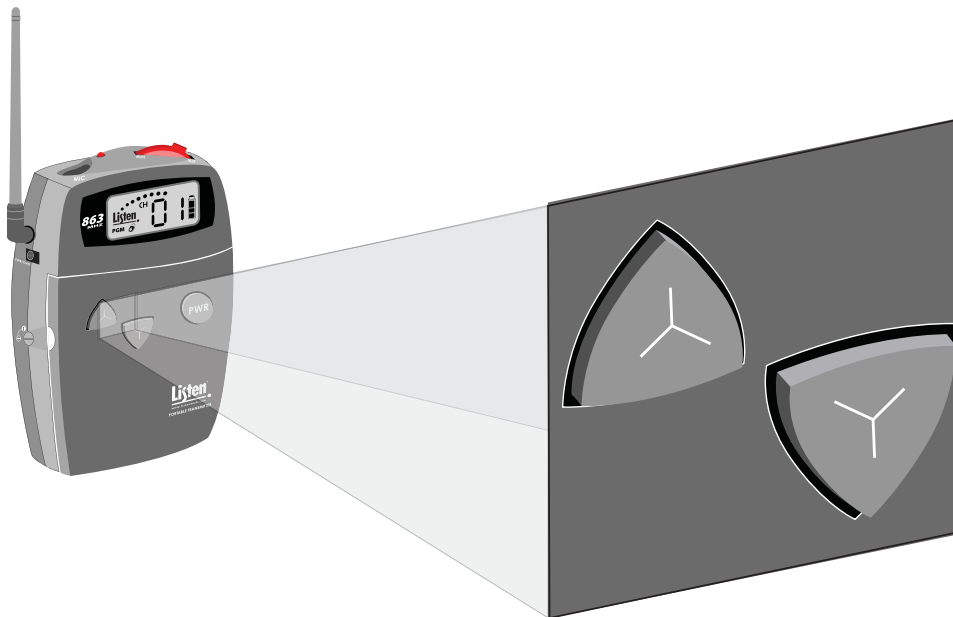

- 2 The "PGM" icon on the LCD will appear indicating program mode is entered.

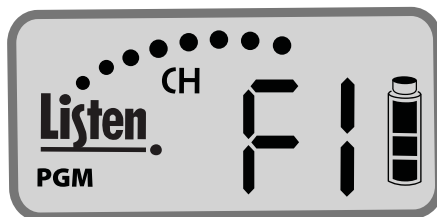

LT-700 Programming Instructions

- 3** Once in the program mode, a function menu is displayed. Function 1 (F1) is displayed as default. Pressing the channel up or down buttons will scroll through the functions. Pressing the power button will enter that function.

F1- Channel Lock out. No channels are locked out as default. Pressing the up and down buttons will scroll through channels. Pressing the power button will toggle between lock/lockout for that channel. When a channel is locked out, the L/O on the LCD shall be displayed.

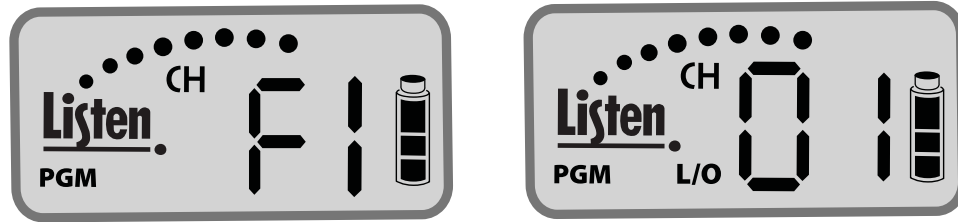

F2- Transmitter Power. High transmit power (P3) is the default. Pressing the channel up button will toggle through the following settings:

- Low power: LCD displays "P1"
- Med power: LCD displays "P2"
- High power: LCD displays "P3"

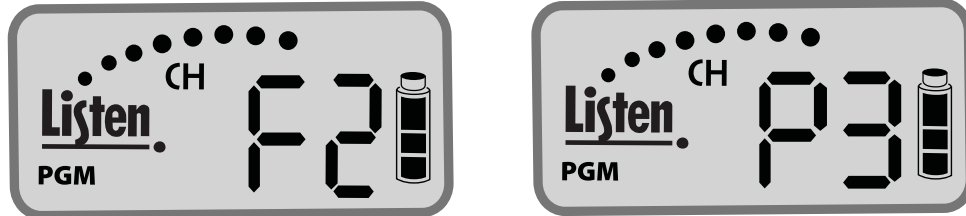

- 4** When no button is pressed for 10 seconds, the program menu is exited altogether, regardless of whether a function is entered or not. To exit out of the program menu or function manually:

- 4A** When in the programming menu: Press and hold power for 2 seconds. This exits the program mode.
- 4B** When in a programming function: Press and hold power for 2 seconds. This exits the function and goes back to the programming menu.
- 4C** Pressing and holding power for a full 4 seconds will exit both programming function and programming menu.

LT-700 Programming Instructions

Resetting to defaults

To reset the transmitter to default settings, follow these instructions:

3 Reset to default settings

4A Press and hold the Up and Down channel buttons while turning the unit on.

Press and hold the Up and Down channel buttons while turning the unit on. This will light up all segments of the display.

4B After the transmitter has been reset

After the transmitter has been reset, the display will return with defaults present.

NOTE: The defaults are

- Power Level: P3
- Channel: 01
- * Channel lockout: All channels active

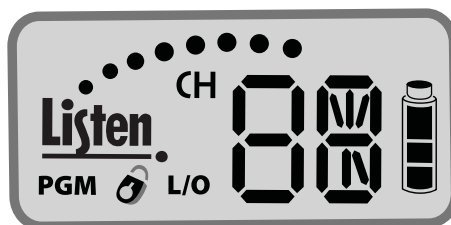

Accessories for LT-700

Accessories



LA-261
Lavalier Microphone



LA-262
Over-the-Head Microphone



LA-272
Over-the-Head Microphone
w/Earphone



LA-274
Hand Held Microphone



LA-276
Collar Microphone



LA-277
Conference Microphone



LA-278
Behind-the-Head
Microphone



LA-304
Assistive Listening
Notification Signage Kit



LA-361
High Capacity AA Alkaline
Batteries (2)



LA-311 16-Unit Portable Charging/Carrying Case

LA-313 16-Unit Portable Carrying Case

LA-317 4-Unit Portable Charging/Carrying Case

LA-318 4-Unit Portable Carrying Case

LA-320 Configurable Carrying Case

LA-321 8-Unit Portable Charging/Carrying Case

LA-322 8-Unit Portable Carrying Case

LA-323 4-Unit Portable Charging/Carrying Case w/Removable Lid

LA-324 8-Unit Portable Charging/Carrying Case w/Removable Lid

LA-325 16-Unit Portable Charging/Carrying Case w/Removable Lid



LA-362
Rechargeable AA NiMH
Batteries (2)

Notes

LT-700



863.050

863.200

863.400

863.5



LR-400 Portable Display FM Receiver

LR-500 Portable Programmable Display FM Receiver

Don't miss a single sound.

LR-400/500 User's Manual Table of Contents

Specifications	37
Block Diagram	39
Quick Reference	40
Setup Instructions	42
Operating Instructions	45
Programming Instructions (LR-500 only)	51
Accessories	52
Notes	53

LR-400/500 Package Contents

- LR-400/500
- Quick Reference Card
- Warranty Card



LR-400-863
Portable Display
FM Receiver
(863 MHz)



LR-500-863
Portable Programmable
Display FM Receiver
(863 MHz)

LR-400/500

Listen Configurations

- LR-400-863
- LR-500-863

LR-400-863 Specifications

Architectural Specification

The LR-400-863 FM receiver shall be capable of receiving on 17 wide band channels with a SNR of 70 dB or greater. The device shall be able to be locked on a single channel. The receiver shall be capable of seeking channels. The device shall have an adjustable squelch. The device shall have an audio frequency response of 50 Hz to 15 KHz, ± 3 dB. The device will incorporate a stereo headset jack that allows the user to plug in either a mono or stereo headset. The device shall incorporate an LCD display that indicates channel, battery level, low battery, battery charging, and RF signal strength. The receiver shall be able to function in both DX and Local mode. The unit shall operate off of 2 AA batteries. The receiver shall incorporate automatic battery charging circuitry for recharging of NiMH batteries. The Listen LR-400-863 is specified.

	Specifications	LR-400-863
RF	RF Frequency Range	863.050 - 864.950 MHz
	Number of Channels	17 Wideband
	Sensitivity	.6uV typical, 1 uV maximum for 12 dB sinad
	Frequency Accuracy	$\pm .005\%$ stability 32 to 122° (0 to 50° C)
	Antenna	Integrated External Antenna
	Squelch	Programmable in 20 steps, automatic on loss of RF signal
	Compliance	CE, ETSI, RoHS
Audio	System Frequency Response	50 Hz - 15 kHz (+/-3 dB)
	System Signal to Noise Ratio	70 dB (A-Weighted)
	System Distortion	<2% total harmonic distortion (THD) at 80% deviation
	Output	3.5 mm connector, unbalanced, 0dBu nominal output level, 16 mW maximum, impedance 32 Ohms
Controls	User Controls	Channel up/down, SEEK, volume
	Set-up Controls (battery compartment)	Alkaline/NiMH battery switch
	Programming	Channel Lock, DX/Local, squelch
Indicators	LED	Red, illuminated when unit is on. Flashes when batteries are low, or Charging. Flashes when locked and SEEK is pushed.
	LCD Display	Channel Designation, lock status, signal strength indication, battery life
Power	Battery Type	Type: 2 AA batteries, alkaline or NiMH
	Battery Life (Listen batteries)	20 hours alkaline (LA-361), 10 hours NiMH rechargeable (LA-362)
	Battery Charging (NiMH only)	Fully Automatic, 13 hours maximum
Physical	Dimensions (H x W x D)	5.0 x 3.0 x 1.0 in (13 x 7.6 x 2.5 cm)
	Color	Dark Grey with white silk screening
	Unit Weight	3.9 oz (111 g)
	Unit Weight with batteries	5.8 oz (164 g)
	Shipping Weight	1.0 lbs. (0.45 kg)
	Door	Manually Lockable. Up, down, and power buttons through door. Other controls behind door (see controls)
Environmental	Temperature - Operation	-10 C (14 F) to +40 C (104 F)
	Temperature - Storage	-20 C (-4 F) to +50 C (122 F)
	Humidity	0 to 95% Relative Humidity, non condensing

Specifications are subject to change without notification

LR-500-863 Specifications

Architectural Specification

The LR-500-863 FM receiver shall be capable of receiving on 17 wide band channels with a SNR of 70 dB or greater. The receiver shall be programmable to electronically lock out unneeded channels. The receiver shall be capable of seeking channels. The device shall be able to be locked on a single channel. The device shall have an adjustable squelch. The device shall have an audio frequency response of 50 Hz to 15 KHz, ± 3 dB. The device will incorporate a stereo headset jack that allows the user to plug in either a mono or stereo headset. The device shall incorporate an LCD display that indicates channel, battery level, low battery, battery charging, and RF signal strength. The receiver shall be able to function in both DX and Local mode. The unit shall operate off of 2 AA batteries. The receiver shall incorporate automatic battery charging circuitry for recharging of NiMH batteries. The Listen LR-500-863 is specified.

	Specification	LR-500-863
RF	RF Frequency Range	863.050 - 864.950 MHz
	Number of Channels	17 Wideband
	Sensitivity	.6uV typical, 1 uV maximum for 12 dB sinad
	Frequency Accuracy	$\pm .005\%$ stability 32 to 122° (0 to 50° C)
	Antenna	Integrated External Antenna
	Squelch	Programmable in 20 steps, automatic on loss of RF signal
	Compliance	CE, ETSI, RoHS
Audio	System Frequency Response	50 Hz - 15 kHz (+/-3 dB)
	System Signal to Noise Ratio	70 dB (A-Weighted)
	System Distortion	<2% total harmonic distortion (THD) at 80% deviation
	Output	3.5 mm connector, unbalanced, 0dBu nominal output level, 16 mW maximum, impedance 32 Ohms
Controls	User Controls	Channel up/down, SEEK, volume
	Set-up Controls (battery compartment)	Alkaline/NiMH battery switch
	Programming	Channel Lock Out, Channel Lock, DX/Local, squelch
Indicators	LED	Red, illuminated when unit is on. Flashes when batteries are low, or Charging. Flashes when locked and SEEK is pushed.
	LCD Display	Channel Designation, lock status, signal strength indication, programming
Power	Battery Type	Type: 2 AA batteries, alkaline or NiMH
	Battery Life (Listen batteries)	20 hours alkaline (LA-361), 10 hours NiMH rechargeable (LA-362)
	Battery Charging (NiMH only)	Fully Automatic, 13 hours maximum
Physical	Dimensions (H x W x D)	5.0 x 3.0 x 1.0 in (13 x 7.6 x 2.5 cm)
	Color	Dark Grey with white silk screening
	Unit Weight	3.9 oz (111 g)
	Unit Weight with batteries	5.8 oz (164 g)
	Shipping Weight	1.0 lbs. (0.45 kg)
	Door	Manually Lockable. Up, down, and power buttons through door. Other controls behind door (see controls)
Environmental	Temperature - Operation	-10 C (14 F) to +40 C (104 F)
	Temperature - Storage	-20 C (-4 F) to +50 C (122 F)
	Humidity	0 to 95% Relative Humidity, non condensing

Specifications are subject to change without notification

LR-400/500 Block Diagram

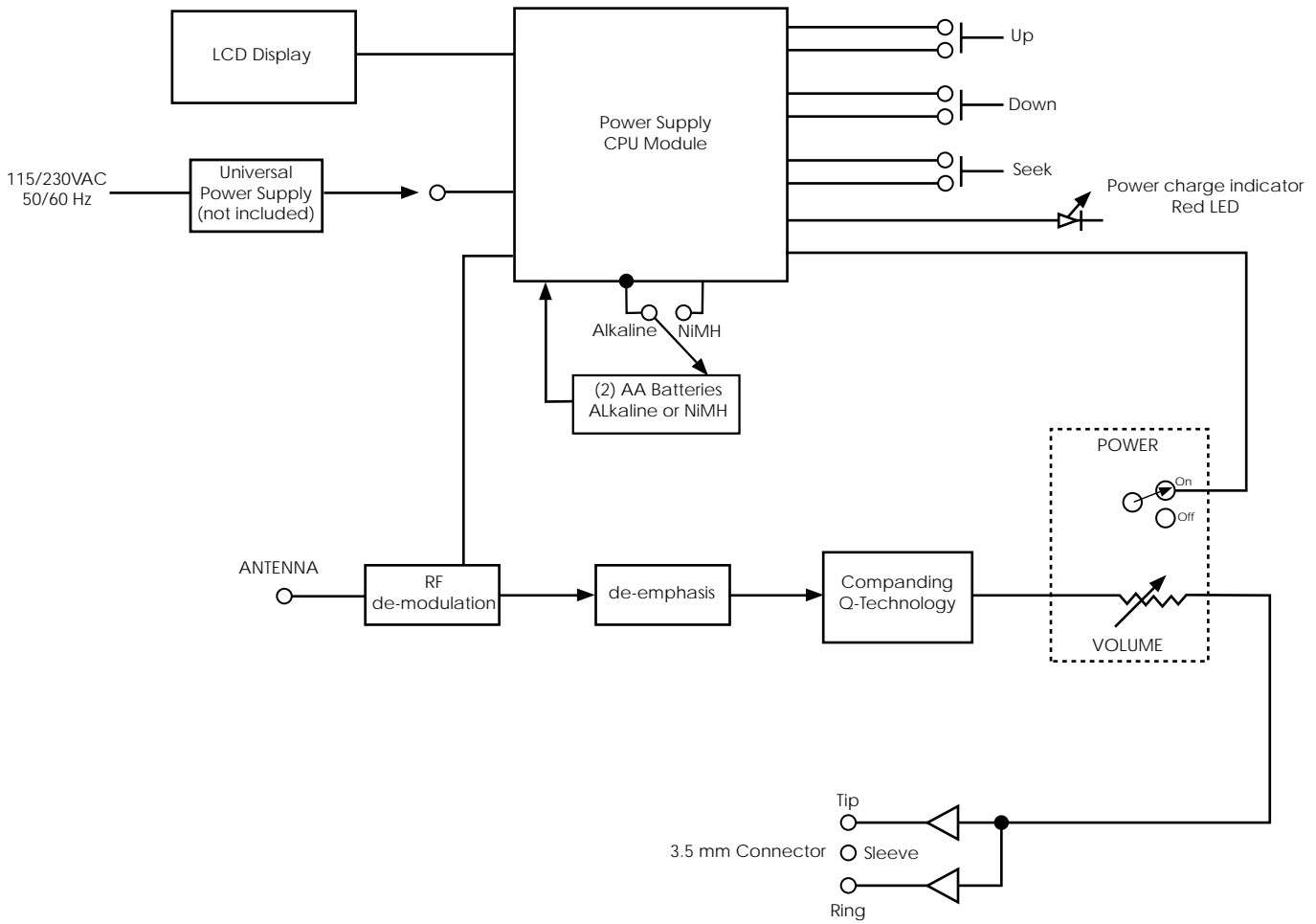

LR-400-863 Quick Reference

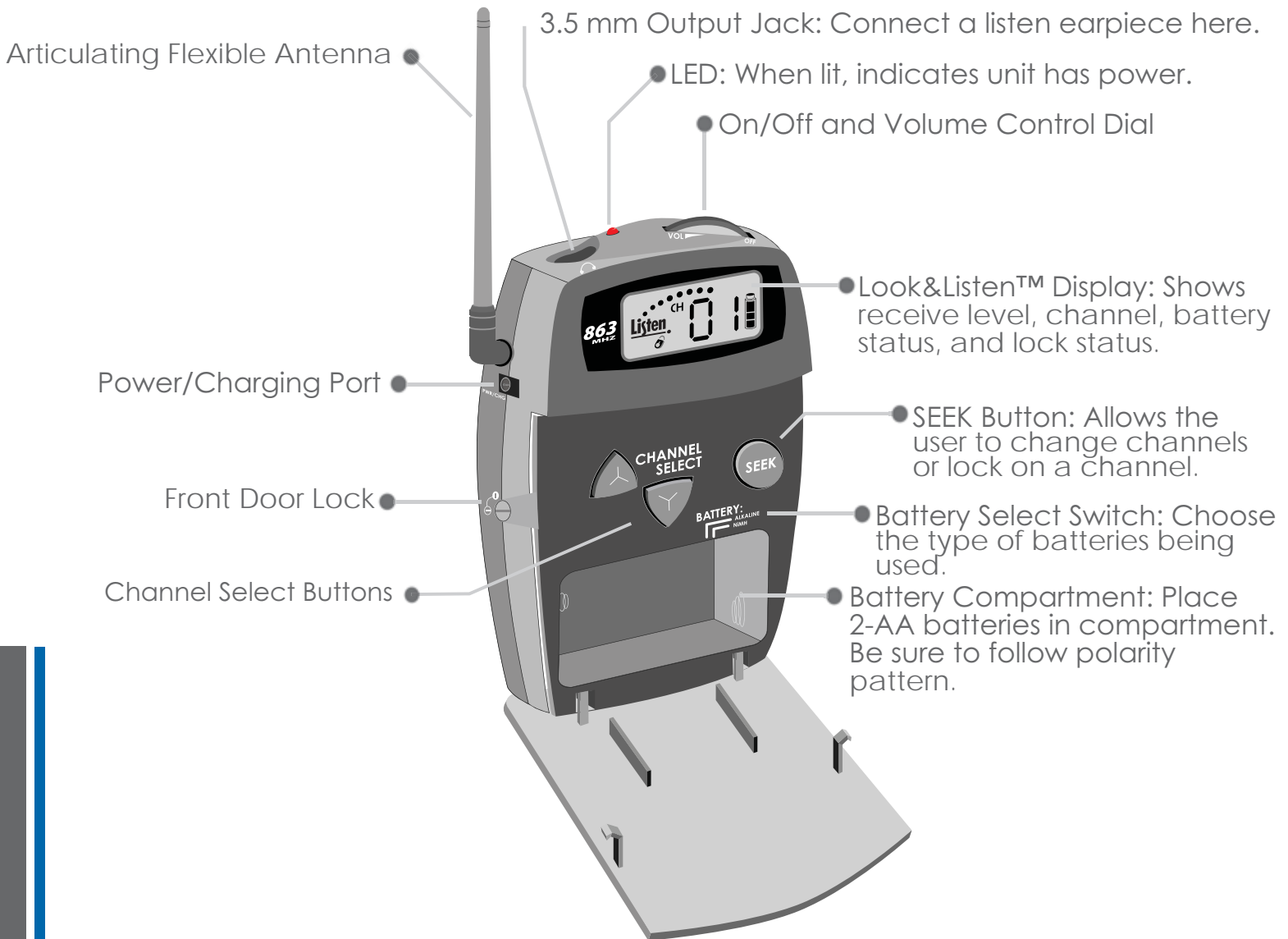

Channel Display: Displays the channel the LR-400 is currently on.

RF Input Indicator: Indicates the RF receive level.

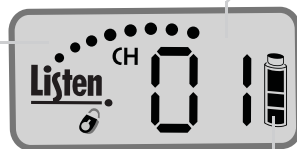

Battery Level Indicator

Lock Icon: Indicates the unit is locked on current channel.

LR-500-863 Quick Reference

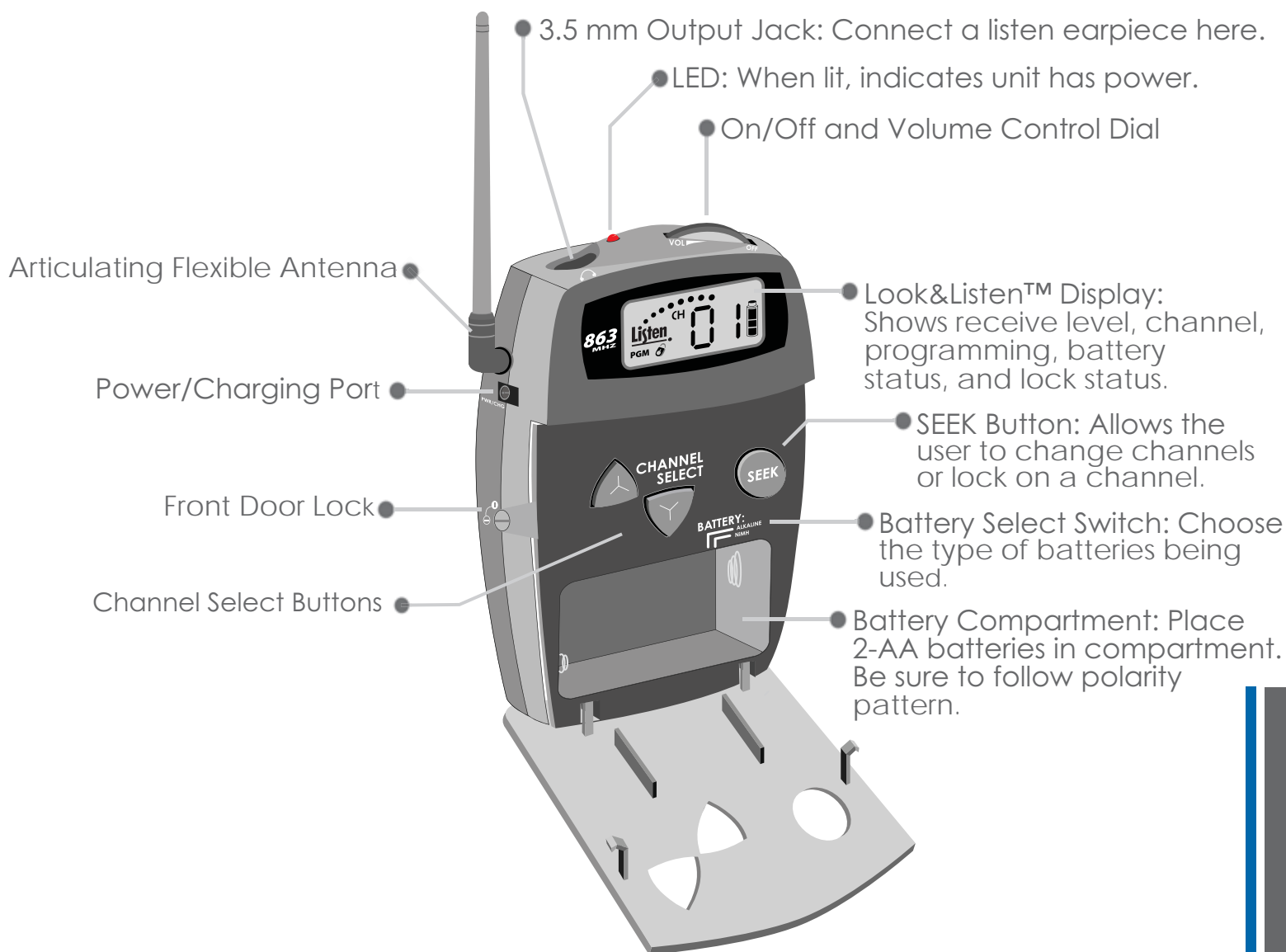

Channel Display: Displays the channel the LR-500 is currently on.

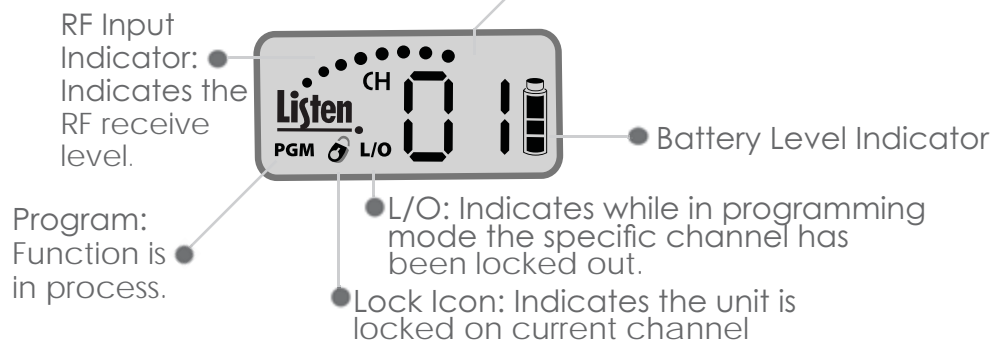

LR-400/500 Setup Instructions

1 Remove the product

Remove outer packaging and plastic cover. Inspect for physical damage. If damage is apparent, please contact the dealer from which the product was purchased or Listen Technologies Corporation technical support for assistance (refer to page 67 for contact information).

2 Open the front access door

If locked, use a pocketknife or small screwdriver to unlock the door locks on both sides of the unit. To unlock the door, rotate the lock $\frac{1}{4}$ turn counterclockwise. Grip the two tabs with your thumb and index finger and pull the door downward. DO NOT place batteries in the unit at this time.

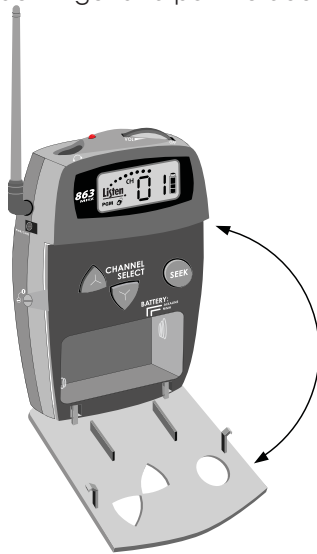

3 Select Battery Type

Two types of batteries may be used: The unit is shipped with the switch in the Alkaline position. Use a pen or small screwdriver to select the battery type.

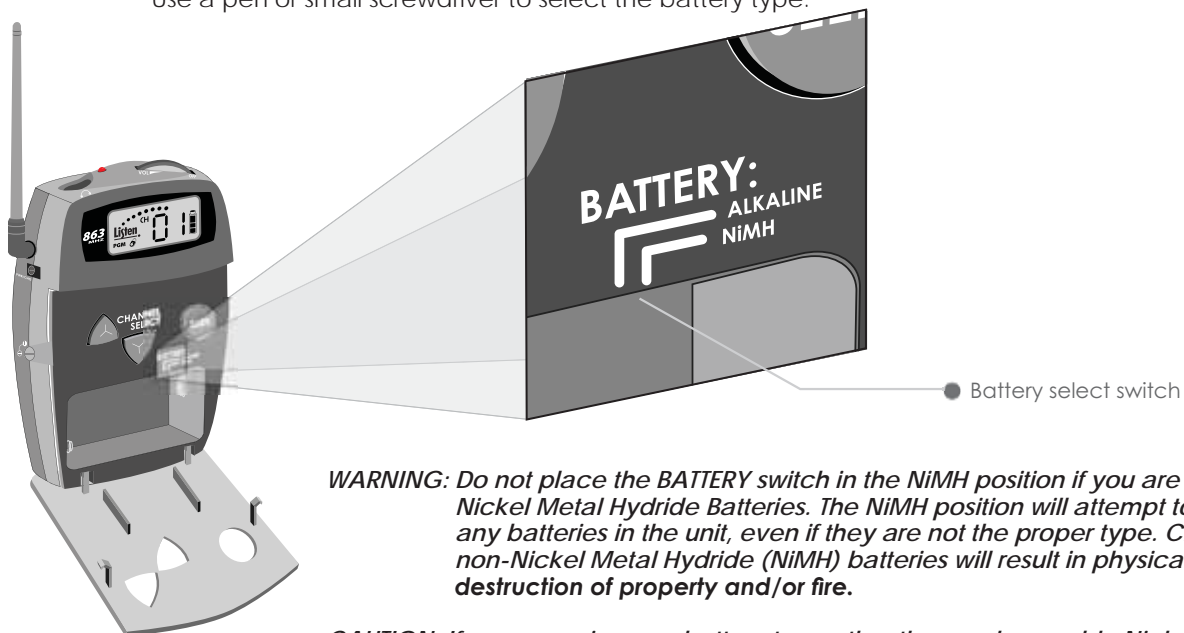

WARNING: Do not place the BATTERY switch in the NiMH position if you are not using Nickel Metal Hydride Batteries. The NiMH position will attempt to charge any batteries in the unit, even if they are not the proper type. Charging non-Nickel Metal Hydride (NiMH) batteries will result in physical harm, destruction of property and/or fire.

CAUTION: If you are using any battery type other than rechargeable Nickel Metal Hydride (NiMH) batteries, make sure the BATTERY selection switch is in the alkaline position.

LR-400/500 Setup Instructions

4 Place Batteries in Unit

Place two AA batteries in the compartment, making note of the battery polarity shown in the battery compartment, and again verifying that the BATTERY SELECT switch is in the correct position for the batteries you are using. (Alkaline should be selected for all battery types other than NiMH).

NOTE: Listen provides industrial strength AA alkaline batteries (part number LA-361) and high performance AA Nickel Metal Hydride batteries (part number LA-362). These may be purchased from your Listen dealer.



5 Connect an Earphone or Headset

Your headset or earphone will connect to the jack on the top of the unit. Either mono or stereo connectors may be used with a Listen receiver. Make certain you push the plug all the way into the jack.



LR-400/500 Setup Instructions

6 Turn the Unit On

Receivers are turned on by rotating the volume dial counterclockwise. The red LED on top of the unit will illuminate and the LCD display should illuminate. If they do not, make sure you have installed the batteries correctly and that you are using fully charged batteries.



LR-400/500 Operating Instructions

1 Turn Unit On

1A Volume knob

Rotate the volume knob counterclockwise with an earphone or headset connected to the unit.

WARNING: Excessive volume may result in hearing damage.

2 Antenna Placement

2A Antenna Position

Raise the antenna to the upright position. When the antenna is fully extended, it will click into position.

NOTE: Be aware that the transmission range could decrease if the antenna is not in an upright position.



3 Select a Channel

3A Select the channel using channel select buttons

Select the channel to match the transmission channel by pressing the UP and DOWN buttons on the receiver.

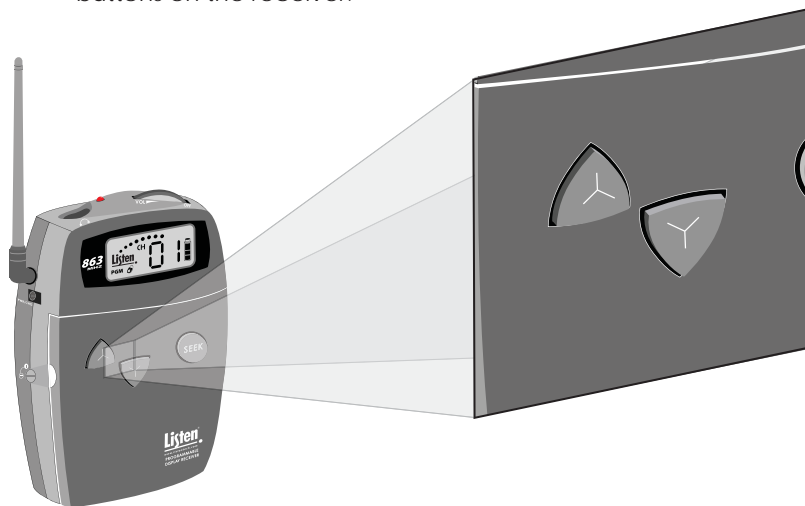

LR-400/500 Operating Instructions

3A Select the channel using SEEK

Another way to find a channel on the LR-400/500 is to use the SEEK button. When you do this, the Listen receiver looks for the next active channel. Sometimes the unit will mistake interference for a real broadcast signal. If you get interference, press the SEEK button again. The unit may stop on a channel that is close to the actual broadcast channel, in which case the channel will sound noisy or distorted. Simply press SEEK again until you find the clearest operating channel.

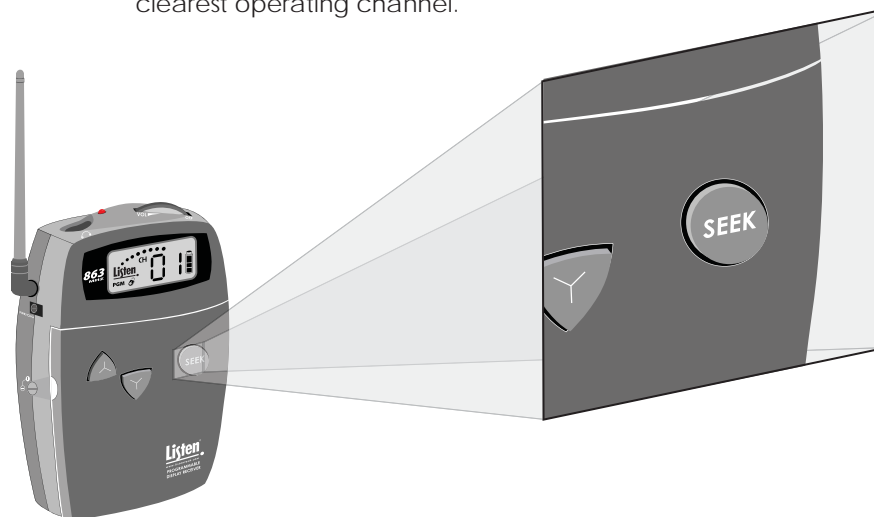

4 Adjust the volume control

Use the control dial on the top of the unit to adjust the volume to a comfortable level.



LR-400/500 Operating Instructions

Locking the Receiver on One Channel

The unit can be electronically locked on one channel so that it will not change channels even if the "SEEK" button is pressed. It is recommended to lock the receiver on a channel that is being used in a single channel system or when multiple systems are in the same area.

1 To lock on a channel

1A Press and hold the SEEK button for 5 seconds

Press and hold the SEEK button for 5 seconds to lock a receiver onto the currently tuned channel. Press and hold the button again to unlock. When locked the LED on top of the unit will flash when you press the SEEK button.

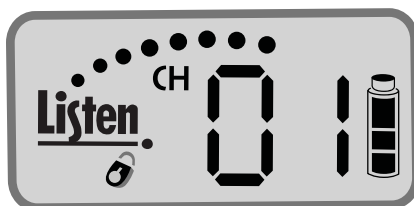

NOTE: On the LR-400/500, when the channel is locked, a lock icon will appear underneath "Listen" on the display. Also if the unit is locked, the red LED on top of the receiver will flash when the SEEK button is pressed.

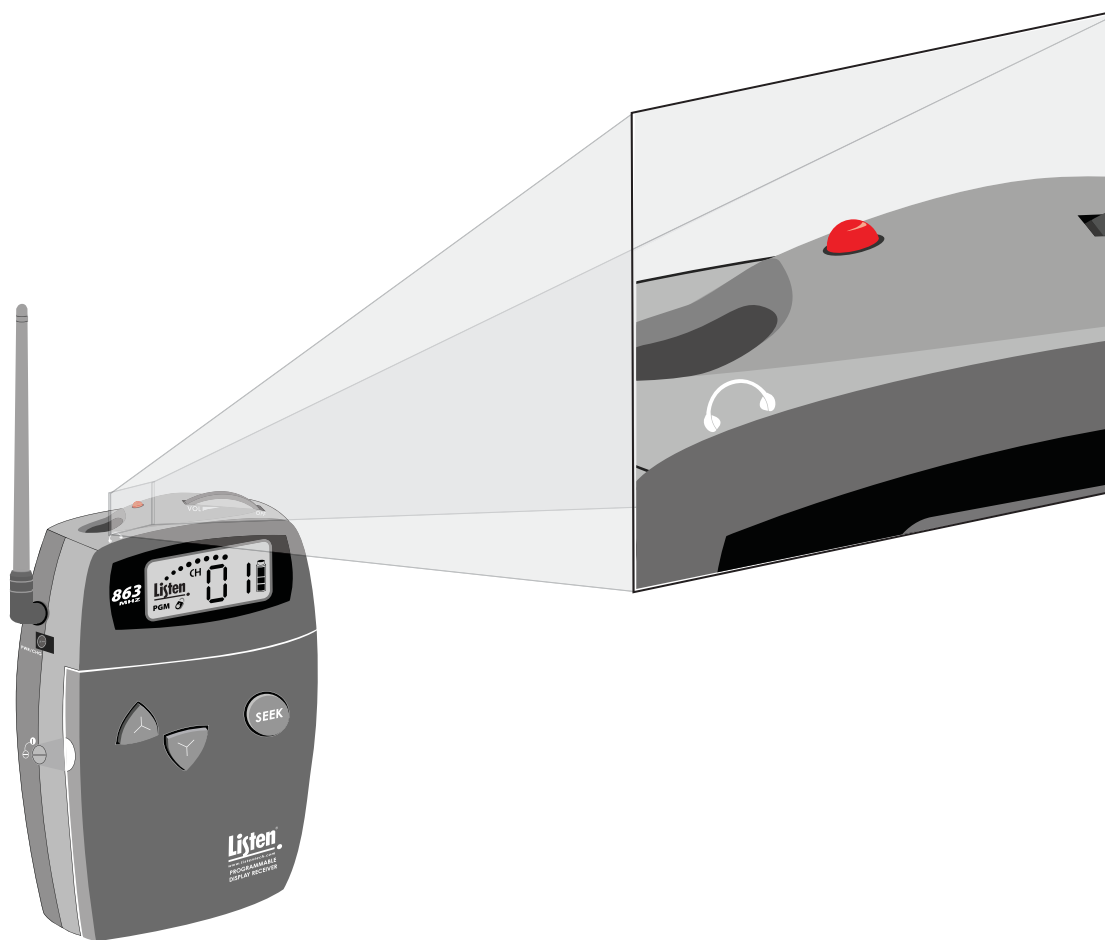

LR-400/500 Operating Instructions

Squelch Programming

Entering Squelch Program Mode

- 1 Turn unit off
- 2 Press and hold the SEEK button; while holding SEEK button down, turn the ON/OFF/VOLUME dial to turn the unit on.
- 3 Release the SEEK button when the Listen name disappears (approximately 2 seconds) and a two digit display is seen.

Adjusting the Squelch level

- 1 Use the Channel UP and DOWN buttons to raise or lower the squelch sensitivity settings (refer to the chart on page 49 for settings).
- 2 Lower numbers mean that a less powerful and possibly noisy signal will be heard, but you can have a longer range before the unit will squelch.
- 3 Once the desired squelch setting is found, press SEEK to exit the squelch programming mode.

NOTE: Keep in mind, low squelch may allow multipath and squelch chattering at long distances.

Squelch setting 00 is no squelch; this setting disables the squelching capabilities of the receiver. Squelch setting 20 is maximum squelch sensitivity; when on this setting, there must be a very strong and stable RF signal for the unit to not engage the squelch feature.

NOTE: For squelch settings 1-3, the squelch function is slow which allows for maximum transmission range. For squelch settings 4-20 the squelch function is fast to ensure little radio noise is heard during the squelch function.



LR-400/500 Operating Instructions

Squelch

The purpose of squelch is to mute the audio output of your receiver when the signal from the transmitter is turned off or is too weak to be received. Without squelch you would hear radio noise in your earphone. The squelch on your receiver can be adjusted so that it will mute the audio on different RF signal strengths. This is useful as follows:

Set the squelch setting to the highest level

To ensure that users don't hear transmissions from other transmitters, set the squelch setting to the highest level that doesn't squelch the receiver.

If the receiver is close to the transmitter, set the squelch high

If the receiver is going to be close to the transmitter (i.e. in a classroom), set the squelch setting high so that when the transmitter is turned off it immediately squelches and ignores transmitters in other rooms.

If in an area that has a lot of interference, set the squelch high

If you are in an area that has a lot of inference, you may want to set the squelch setting to a high setting to ensure the interference is not picked up by the receiver.

For maximum amount of range, set the squelch to a low level

If you need the maximum amount of range, you may want to consider setting the squelch setting to a low level (0, 1 or 2).

NOTE: Default squelch setting is 3

CAUTION: When setting the squelch level low the reliability of squelch function is compromised. This will cause radio noise to be heard in the earphone and there is a possibility of hearing damage.

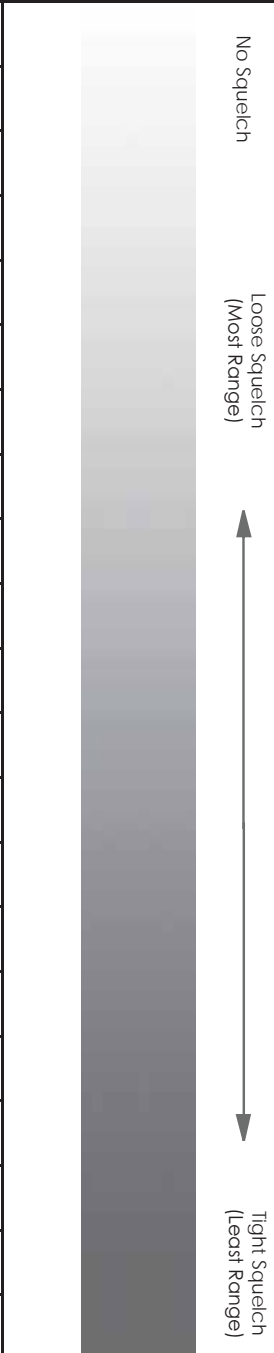
Squelch Setting	Squelch
0	
1	
2	
3 (default)	
4	
5	
6	
7	
8	
9	
10	
11	
12	
13	
14	
15	
16	
17	
18	
19	
20	

LR-400/500 Operating Instructions

DX/Local

DX is the normal operational mode. Local mode can effectively limit any inter-modulation and/or interference in a busy RF environment. This is done by limiting the amount of RF gain in the receiver. When local mode is selected, the range of the receiver is compromised. Depending on your application and environment, Local mode may be necessary for better performance. DX mode is default.

DX Mode (default)

DX is normal operation. The local mode feature can be used when many frequencies are being used.

Local mode

Only strong channels will be automatically tuned in

1 To change to DX/Local mode

- 1A While the unit is OFF, press and hold the channel down button and turn the unit on.
- 1B The LCD shall indicate the current setting "D" or "L".
- 1C Pressing the down button will toggle between Local and DX Mode; "D" or "L".
- 1D Pressing seek will enter the setting and return to normal operational mode.

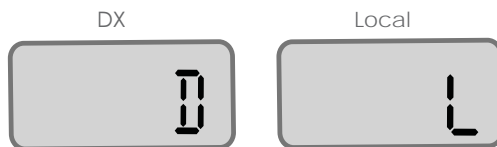

Resetting to defaults

To reset the receiver to default settings, follow these instructions:

1 Reset to default settings

- 1A **Press and hold the Up and Down channel buttons while turning the unit on.**
Press and hold the Up and Down channel buttons while turning the unit on. This will light up all segments of the display.
- 1B **After the receiver has been reset**
After the receiver has been reset, the display will return with defaults present.

NOTE: The defaults are

- Channel: 01
- * Channel lockout: All channels active



LR-500 Programming Instructions (LR-500 only)

Programming Instructions

The LR-500 can be programmed to receive on a limited number of channels. When an application requires the use of more than one channel (i.e. a classroom or language interpretation), the receiver can be programmed to view only the necessary channels.

Entering Program Mode

1 To enter program mode

- 1A While the unit is ON, press and hold the channel down and up buttons simultaneously for 3 seconds.

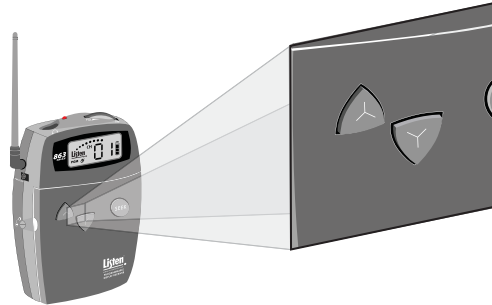

- 1B The "PGM" icon on the LCD will appear indicating program mode is active.

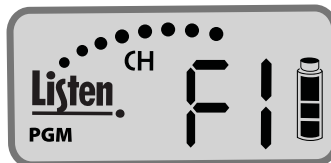

2 To program

- 2A Once in the program mode, a function menu is displayed. Function 1 (F1) is displayed as default. Pressing the channel up or down buttons will scroll through the functions (F1). Pressing the seek button will enter that particular function.

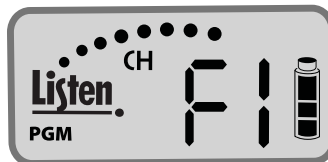

F1- Channel Lock out. No channels are locked out as default. Pressing the up and down buttons will scroll through channels. Pressing the seek button will toggle between available and locked out for that channel. When a channel is locked out, the L/O on the LCD shall be displayed.

NOTE: Although it is possible to display an F2 function while in program mode, there is no F2 function at this time. Listen may add another programming function in the future, but there is only one programming function (F1) on the 863 MHz receivers.

- 3 When no button is pressed for 10 seconds, the program menu is exited altogether, regardless of whether a function is entered or not. To exit out of the program menu or function manually:

- 3A When in the programming menu: Press and hold power for 2 seconds. This exits the program mode.
- 3B When in a programming function: Press and hold power for 2 seconds. This exits the function and goes back to the programming menu.
- 3C Pressing and holding power for a full 4 seconds will exit both programming function and programming menu.

Accessories for LR-400/500

Accessories



LA-164
Ear Speaker



LA-165
Stereo Headphones



LA-166
Neck Loop



LA-170
Behind-the-Head
Stereo Headphones



LA-304
Assistive Listening
Notification Signage Kit



LA-361
High Capacity AA Alkaline
Batteries (2)



LA-362
Rechargeable AA NiMH
Batteries (2)



- LA-311 16-Unit Portable Charging/Carrying Case
- LA-313 16-Unit Portable Carrying Case
- LA-317 4-Unit Portable Charging/Carrying Case
- LA-318 4-Unit Portable Carrying Case
- LA-320 Configurable Carrying Case
- LA-321 8-Unit Portable Charging/Carrying Case
- LA-322 8-Unit Portable Carrying Case
- LA-323 4-Unit Portable Charging/Carrying Case w/Removable Lid
- LA-324 8-Unit Portable Charging/Carrying Case w/Removable Lid
- LA-325 16-Unit Portable Charging/Carrying Case w/Removable Lid

Notes



Portable FM 863 MHz

863.050

863.200

863.400

863.500

Supplementary Information

Don't miss a single sound.

Supplementary Information Table of Contents

Frequency Chart	61
Battery Charging Information	62
Troubleshooting	63
Frequently Asked Questions	65
Compliance, Warranty and Contact Information	67
Notes	68

Frequency Chart

Frequencies	
Channel	Frequency (MHz)
01	863.050
02	863.200
03	863.400
04	863.550
05	863.750
06	863.900
07	864.100
08	864.250
09	864.450
10	864.600
11	864.800
12	864.950
13	863.300
14	863.650
15	864.000
16	864.350
17	864.700

Battery Charging Information

The LT-700 and LR-400/500 receivers are unique because they have SmartCharge™ chargers built in. When any of these units are placed into a Listen charging case, NiMH batteries will be charged.

SmartCharge™ uses a pulse charging, which greatly extends the life of Nickel Metal Hydride (NiMH) batteries. The entire charging process takes about 13 hours. Listen recommends that you allow the charger to complete its full cycle every time for maximum battery life.

During the charge cycle, the red LED on top of the Listen product will flash slowly. When charging is completed, the LED will turn off. It is not necessary to unplug the charger; however, if you unplug the unit from the charger and then plug it back in, it will begin the 13-hour charge cycle over again.

When not using the receiver, it is recommended to leave the unit on the charger. The charger provides a "maintenance" charge that keeps the battery at 100%. If the unit is not on the charger, the battery will lose up to 20% of its charge per month.

NOTE: Listen provides 2300 mA_H (milli-Amp-hour) constant current (NiMH Nickel Metal Hydride) batteries. These may be purchased from Listen (part number LA-362).

Charging with a drop-in charger

To charge the batteries using a drop-in charger, simply place the unit into a slot in the charger and connect the charger to power. Make sure the unit is fully seated in its slot.



IMPORTANT: DO NOT ATTEMPT TO CHARGE ANY TYPE OF BATTERY OTHER THAN NiMH (NICKEL METAL HYDRIDE) with your Listen equipment. Alkaline batteries may explode when connected to a charger. Other risks of charging non-NiMH batteries include destruction of property or fire.

IMPORTANT: In order to charge NiMH batteries, the BATTERY SELECT switch in your Listen product must be set to the NiMH setting. Use a pen or small screwdriver to move the switch (located in the battery compartment) to the proper position.

WARNING: The case lid MUST be open or removed while the units are charging. The charging process generates heat. Air ventilation is required. It is best to store your charging case at room temperature away from heat sources and direct sunlight

Troubleshooting

The unit has no power.

Make sure the unit has fully charged batteries. Press the POWER button. If this does not work, try a different set of batteries. Make sure the batteries are installed correctly.

There is no audio.

Make sure the MUTE/TALK switch is in the TALK position. Make sure you have the microphone plugged all the way into the input jack. Make sure you are using a Listen approved microphone (see list on page 21). If you are using the line input, make sure you have connected a line level, unbalanced input at the "ring" of the connector. Also, be sure the receiver is on, volume is turned "up", and headphones are placed firmly in the jack .

The audio is distorted.

Make sure you are using an approved Listen microphone. Try using a different mic sensitivity switch setting (the switch is located inside the battery compartment of the unit). If you are using a line level input, try turning down the level of the input. Make sure the receiver is "ON" and receiving the appropriate channel.

There is hum in the audio.

The microphone may be too close to a transformer. Try moving away from the transformer and see if the hum goes away.

The microphone level is low.

The mic sensitivity switch may be on the wrong setting, (see page 21). Try a different setting (the switch is located inside the battery compartment). Some microphones have directional pickups, ensure that the microphone in use is oriented and positioned properly (pointing at the speaker's mouth). The microphone must be in close proximity to the person who is speaking. If this does not work, try using a head-worn microphone.

There is too much noise.

This is most likely because the microphone is not close enough to the talker's mouth, and it is picking up background noise. Try positioning the microphone closer or try using a microphone that is directional (such as a head-worn mic). Try another setting on the mic sensitivity switch (located inside the battery compartment).

There is interference.

Try different frequencies to find a clear channel. Use a receiver to sweep the area without any transmitters "on". The receiver will stop on any channels that are being broadcasted in the area. Avoid the channels that the receiver detects having a signal.

I cannot pick up the signal on the receiver.

Make sure the transmitter and the receiver are on the same frequency channel.

It's confusing for users to have 17 available channels.

Use the PROGRAM function (LT-700 and LR-500 only) to lock out unwanted channels. Users will only be able to scroll through available channels.

I cannot change the channel.

The transmitter or receiver may be locked on a channel (check for the padlock icon). To unlock, press and hold the UP or DOWN button for 5 seconds.

Troubleshooting

My batteries are not charging

Make sure you are using NiMH batteries and that the BATTERY SELECT switch (inside the battery compartment) is set to the NiMH position. Make sure the batteries are installed correctly. Make sure you are using a Listen charging case. Make sure the charging case is connected to power and the unit is securely pushed into its slot in the case.

NOTE: Listen uses 2300 mAh (milli-Amp-hour) constant current NiMH (Nickel Metal Hydride) batteries. These may be purchased from a Listen dealer (ask for part number LA-362).

Frequently Asked Questions

Frequently Asked Questions

- Q** Do I need a transmitter for each audio source?
A Yes. To transmit two different frequencies, there must be two separate transmitters.
-
- Q** What is the range of the LT-700 Transmitter?
A The range of the LT-700 will depend upon the power setting and interference (refer to page 8). Generally the range is up to 61 m (200 ft.).
-
- Q** Is there a limit to the number of transmitters I can use in one room?
A Yes. Listen recommends that no more that 8 channels are in used simultaneously (refer to page 9 on using multiple channels in the same room).
-
- Q** What receiver should be used with multiple transmitters?
A We recommend the LR-500 for use with multiple transmitters, because the LR-500 is programmable and can lock out unused channels.
-
- Q** How many channels can I program into the LR-500?
A 1 to 17. The receiver has 17 channels and you can program it to have just the channels you want to have access to. It can be a two channel receiver, a 12 channel receiver, or keep all 17.
-
- Q** How many receivers can I have in a system?
A As many as you need, the number is endless.
-
- Q** What are the major differences between the LR-400 and the LR-500?
A Both receivers can tune to 17 broadband channels. However, the LR-400 has the buttons under the battery compartment door and the LR-400 is not programmable to lock out channels. If you plan to use one receiver with multiple transmitters you should use the LR-500 which is programmable to just those channels you need.
-
- Q** What is the battery life of the LT-700 Transmitter?
A Fifteen hours alkaline. Eight hours NiMH.

Frequently Asked Questions

Frequently Asked Questions

Q Can the receiver be "locked" on a channel if needed?
A Yes. All Listen receivers can be locked on a single channel.

Q What is the battery life of a receiver?
A 20 hours using alkaline batteries. 10 hours using NiMH batteries.

Compliance, Warranty and Contact Information

Compliance Information

The following compliance information applies to the LT-800-863, LT-700-863, LR-500-863 and LR-400-863

These devices comply with ETSI EN 301 357

These devices are CE compliant.

These devices are RoHS compliant.



Warranty

Listen Technologies Corporation (Listen) warrants its transmitters and receivers (models LT-700, LT-800, LR-42, LR-44, LR-100, LR-300, LR-400, LR-500 and LR-600) to be free from defects in workmanship and material under normal use and conditions for the useful lifetime of the product from date of purchase.

Listen warrants its Stationary IR Radiators (LA-140) to be free from defects in workmanship and material under normal use and conditions for three years from the date of purchase.

Listen warrants its Noise Canceling Microphone (LA-270) to be free from defects in workmanship and material under normal use and conditions for one year from date of purchase.

All other products and accessories are warranted for 90 days from date of purchase.

This warranty is only available to the original end purchaser of the product and cannot be transferred. Warranty is only valid if warranty card has been returned, or online warranty registration, has been completed within 90 days of purchase. This warranty is void if damage occurred because of misuse or if the product has been repaired or modified by anyone other than a factory authorized service technician. Warranty does not cover normal wear and tear on the product or any other physical damage unless the damage was the result of a manufacturing defect. Warranty does not include inbound freight costs. Listen is not liable for consequential damages due to any failure of equipment to perform as intended. Listen shall bear no responsibility or obligation with respect to the manner of use of any equipment sold by it. Listen specifically disclaims and negates any warranty of merchantability or fitness of use of such equipment including, without limitation, any warranty that the use of such equipment for any purpose will comply with applicable laws and regulations. The terms of the warranty are governed by the laws of the state of Utah.

In the first ninety days after purchase, any defective product will be replaced with a new unit. After 90 days, Listen will, at its own discretion either repair or replace transmitters and receivers with a new unit or a unit of similar type and condition. Product that is not covered under warranty shall be repaired or replaced with a unit of similar type and condition based on a flat fee.

This limited warranty, prices and the specifications of products are subject to change without notice.

Contacting Listen

If technical service is needed, please contact Listen. Pre-authorization is required before returning Listen products. If products were damaged in shipment, please contact the carrier, then contact Listen for replacement or repair requirements payable by the carrier.

All Listen European markets are supported through the Listen Technologies GmbH office located in Oberasbach, Germany. For more information on Listen solutions, contact Listen Technologies at +1.801.233.8992, +1.800.330.0891 North America, Listen Technologies GmbH at +49 911 955159-0 or visit www.listentech.com. For Europe, Middle East, Africa and India office visit www.listentech.de.

14912 Heritagecrest way
Salt Lake City, Utah U.S.A. 84065-4818
+1.801.233.8992
+1.800.330.0891 North America
+1.801.233.8995 Fax
support@listentech.com
www.listentech.com

Listen Technologies GmbH
Jasminstr.16, 90522 Oberasbach, Germany
+49 911 955 159 0 Europe
+49 911 955 159 40 Fax
support@listentech.de
www.listentech.de



www.listentech.com

Listen Technologies Corporation
14912 Heritagecrest Way
Bluffdale, Utah 84065-4818, U.S.A.

+1.801.233.8992

+1.800.330.0891 North America

+1.801.233.8995 Fax

www.listentech.com

info@listentech.com

Listen Technologies GmbH
Jasminstr. 16
905 22 Oberasbach, Germany

+49 911 955159 0 EMEA1

+49 911 955159 40 Fax

www.listentech.de

info@listentech.de

Printed in the United States of America

© 2007 Listen Technologies Corporation® All Rights Reserved 20071015

Free Manuals Download Website

<http://myh66.com>

<http://usermanuals.us>

<http://www.somanuals.com>

<http://www.4manuals.cc>

<http://www.manual-lib.com>

<http://www.404manual.com>

<http://www.luxmanual.com>

<http://aubethermostatmanual.com>

Golf course search by state

<http://golfingnear.com>

Email search by domain

<http://emailbydomain.com>

Auto manuals search

<http://auto.somanuals.com>

TV manuals search

<http://tv.somanuals.com>