

User's Manual

LA-122 Universal Remote Antenna Kit

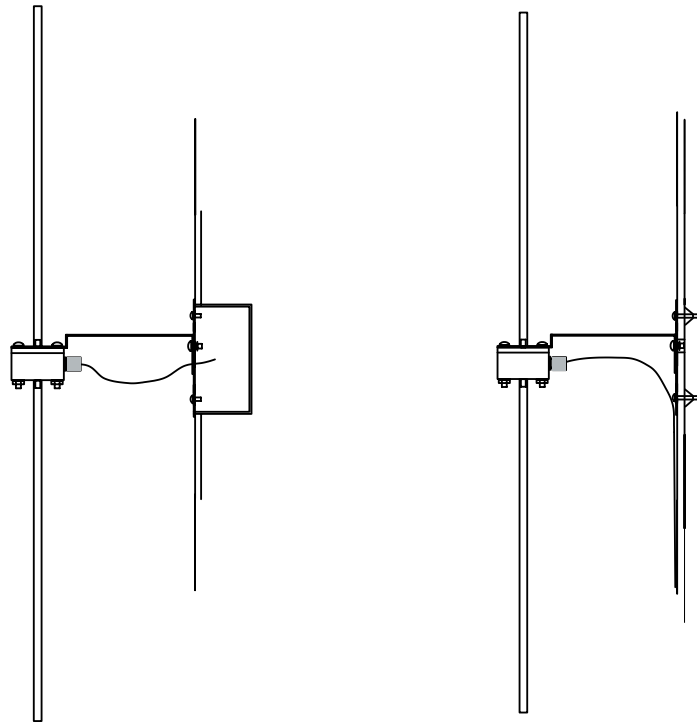

Listen[®]
www.ListenTech.com

Listen Technologies Corporation

8535 South 700 West, Suite A
Sandy, Utah 84070-2515 USA
Telephone: +1.801.233.8992
Toll-Free (USA): 1.800.330.0891
Fax: +1.801.233.8995
E-mail: info@listentech.com

V.020603. Listen and the Listen logo are registered trademarks of Listen Technologies Corporation. Document #LM-122
Copyright © 2002 Listen Technologies Corporation. All Rights Reserved.

Mounting Options:

Wall Mount (to your electrical box)
 Direct Wall Mount
 Ceiling Mount
 In-Wall or In-Ceiling Mount
 Mast Mount

Use With:

LT-800-072 Stationary Transmitter
 LT-800-216 Stationary Transmitter
 LR-100-072 Stationary Receiver /
 Power Amplifier
 LR-100-216 Stationary Receiver /
 Power Amplifier

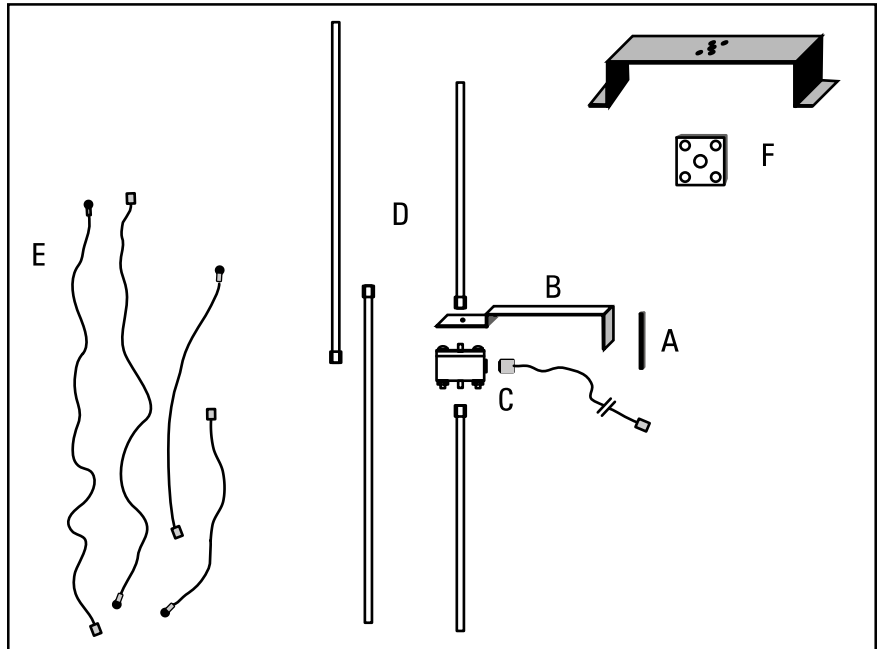

Kit Includes:

- A. Wall / Electrical Box Mounting Plate
- B. Mounting Bracket
- C. Antenna Module and 25 feet (7.6 m) RG58 coaxial cable with BNC connectors
- D. Telescoping antennas (2 for both 72 and 216 MHz)
- E. Flexible antennas (2 for both 72 and 216 MHz)
- F. Ground Plane and Shorting Plate
- G. Mounting Hardware (not shown):
 - (4) #6-32 Machine Screws - used to mount to a single or dual gang duplex box
 - (4) #8-32 Machine Screws - used to mount to a square or hex junction or light box
 - (4) #8 Sheet Metal Screws - used to mount to metal or wood, or for use with dry anchors
 - (4) Dry Anchors - used to mount to drywall, concrete, plaster, brick, or masonry
 - (2) Hex Kep Nuts (#10-32) and (1) Fiber Washer - used for mounting flexible antennas to the Antenna Module, and for grounding purposes

Thank you for purchasing this Listen product! If you have any questions or would like to offer suggestions on future Listen products, please contact us at the address shown below.

Table of Contents

Contents of Kit	page 2
Specifications	page 3
Architectural Specifications	page 3
Important Things to Note Before Starting	page 4
Selecting an Antenna Location	page 6
Choosing Which Antenna to Use	page 6
Dipole Antenna Mounting Options	page 7
Monopole Antenna Mounting Options	page 11
Troubleshooting	page 14
Warranty	page 16

Specifications

Center Frequencies:	73.50 MHz and 216.50 MHz
Antenna Types:	Monopole and Dipole
Antenna Gain:	Unity
Antenna Segment Lengths:	(same for both rigid and flexible antennas) 72 MHz: 39.25 in (1.0 m); 216 MHz: 12.25 in (31.1 cm)
Dipole Vertical Clearance:	72 MHz: 79.75 in (2.03 m); 216 MHz: 25.75 in (65.4 cm)
Connector:	Standard BNC
Coax Provided:	25 ft (7.6 m) RG58 with BNC connectors
Mounting Options:	Wall mount, dual and single electrical box, ceiling electrical box, horizontal surface mount (such as on top of a rack), ceiling / inverse mounting, flexible mounting in-wall or in-ceiling and mast or conduit mount
Mounting Hardware:	Provided. Includes self-tapping sheet metal screws, drywall anchors, and all hardware required to mount to electrical boxes. Does not include hardware required to mount to a mast (available at most hardware stores)
Mounting Bracket Dimensions:	4.5 in (11 cm) wide x 7.0 in (18 cm) deep x 2.5 in (6.4 cm) high
Mounting Plate Dimensions:	4.48 in (11.4 cm) x 4.55 in (11.6 cm)
Shipping Box Dimensions:	2.76 in x 16.3 in x 17.1 in (70 mm x 415 mm x 435 mm)
Weight:	4.4 Lbs. (2 kg)

Architectural Specifications

The Universal Antenna Kit shall be capable of operating from 72.0 to 76.0 MHz with a center frequency of 73.5 MHz and from 216.0 to 217.0 MHz with a center frequency of 216.5 MHz. The kit shall include the necessary mounting hardware to mount the antenna on a single or dual electrical box, directly on a wall, on a ceiling electrical box or on a flat surface. The antenna shall have a BNC connector and the kit shall come with 25 ft (7.6 m) of RG58 coax with BNC connectors. The kit shall include rigid and flexible antenna radials. The Listen LA-122 Universal Antenna Kit is specified.

Important Things to Note Before Starting Your Installation

Coaxial Cable

If you plan to use your own coaxial cable instead of the provided cable, you must use cable and connectors rated at 50 ohms. Although cable used for cable TV installations looks similar to this cable, it won't work with your Listen system.

If you need to run cable over a greater length than 50 feet for 216 MHz applications or greater than 100 feet for 72 MHz applications, we recommend that you use RG-8 cable rather than RG-58. It is a lower loss cable, meaning that more of your signal will reach the antenna.

Long cable runs can result in signal degradation due to "loss" characteristics of the cable. At 72 MHz, there is a loss of 2dB per 100 feet of cable and at 216 MHz, there is a loss of 5 dB per 100 feet of cable. (A 3dB loss means half of your power has been lost.) However, **it is better to suffer coaxial power loss than to try to shoot your signal through obstacles!** Obstacles, especially metal, can create drop-outs or reflections of your signal that will result in poor listening conditions.

Before Starting Assembly of Your Antenna

Please carefully compare the contents of your kit with the list found on page 2 of this manual. If any items are missing or damaged, please contact Listen Technologies. If items were damaged in shipment, contact your carrier immediately and retain all packaging for inspection by your carrier. Listen is not responsible for shipping damage.

Listen Technologies Corporation

8535 South 700 West, Suite A
Sandy, Utah 84070-2515 USA
Telephone: +1.801.233.8992
USA Toll Free: 1.800.330.0891
Fax: +1.801.233.8995
e-mail: info@listentech.com

Antenna Orientation

The antenna's pattern is hemispherical, meaning that it has an "active" side and a ground side. The active side directs the signal toward the receivers, so it is essential that the active side be oriented toward the area where the receivers will be used. The Antenna Module's ground side has the word "GROUND" molded into the plastic.

See Diagram A. If it is necessary to locate an antenna low on a wall, the ground side should face down. If you are mounting a monopole antenna in a ceiling or high on a wall, the ground side should face UP. It may be necessary to move the ground side of the antenna mount around in order to accomplish this.

To move the ground side of the module, simply remove the four nuts, reverse the module so that the ground side is facing the bracket, then re-attach the nuts. Be careful to not detach any wires if the module opens while it is not secured to the bracket.

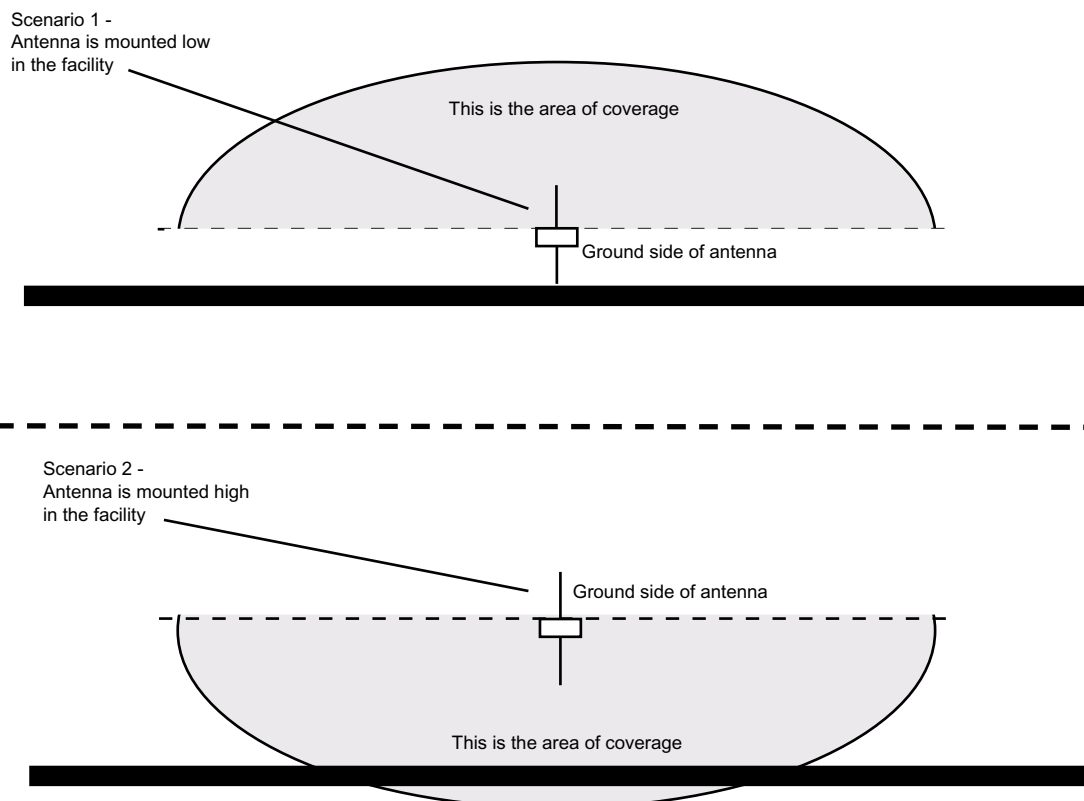

Diagram A. Antenna coverage patterns. In Scenario 1, the antenna is mounted low in the facility. The GROUND side of the antenna (marked on the module) should face down. In Scenario 2, the antenna is mounted high in the facility. The GROUND side of the antenna should face up.

Selecting an Antenna Location

The location and configuration of your antenna mount will determine the quality of your signal; therefore, there are some important factors to consider.

- Where will the receivers be located? Ideally, the antenna will be centrally positioned above that area.
- Where will the transmitter or stationary receiver / power amplifier be located? We recommend that it be located no more than 25 feet (7.6 meters) from the antenna.
- Are there any metal obstructions in the area? Ideally, there will be no metal between the antenna and the receivers. Also, try to avoid mounting the antenna in a location where nearby metal would be in parallel with the antenna – this degrades the signal.
- Will the antenna be mounted outdoors? Antennas work well outdoors, but if possible, try to place the antenna where it will not receive too much exposure to moisture or dirt. Covering exposed connections with petroleum jelly or silicone gel will extend the life of the antenna.

Choosing The Type of Antenna To Use

Several types of antennas are included in this kit. You will only use one of them. How do you select the best antenna?

- First, what is your operating frequency – 72 MHz or 216 MHz? This eliminates half of the antennas since you can only use an antenna that will work for your frequency range. Remember, the LONGER antennas work on the lower frequency of 72 MHz and the SHORTER antennas work at 216 MHz.
- Next, do you have any space restrictions? The rigid dipole antenna (the one with the two extendable arms) provides the best signal, but only if you can fully extend the sections of the antenna. If you can't fully extend the rigid dipole, you will need to go with either the flexible dipole or the monopole antenna. We recommend using a dipole antenna whenever possible.
- If you need to mount your antenna on top of an equipment rack, you will need to use the monopole antenna.
- For mounting in a ceiling or in a wall, or taking up the least amount of space along an outside edge of a wall, the flexible dipole antenna is a good choice. Remember, though, that you need to extend the sections of this "floppy" antenna as far apart from each other as possible.

Dipole Antenna Mounting Options

Mount to an Electrical Box in a Wall

See *Diagram B at right*

The antenna may be mounted to a single or dual gang duplex box, or to a square or hexagonal junction box.

Attach the kit's Mounting Plate to the electrical box (see photo, right). The cover plate has a number of holes and slots to accommodate a wide variety of electrical boxes. Next, secure the Mounting Bracket to the plate and connect your antenna as noted in the following pages.

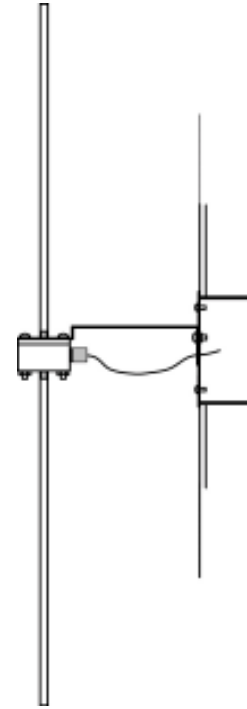

Diagram B. The Electrical Box mount uses the Mounting Plate and Mounting Bracket as shown above.

Mount Directly to a Wall

See *Diagram C at right*

We recommend using the Mounting Plate to make for a sturdier installation, however, it is not necessary to do so. If you use the Mounting Plate, you will need to provide two shallow clearance gaps in the wall to allow for the two protrusions in the Mounting Plate.

Use appropriate anchors to secure the Mounting Plate to the wall (hollow wall anchors are provided in this kit), then secure the Mounting Bracket to the plate. If you are not using the Mounting Plate, use appropriate wall anchors to mount the Mounting Bracket directly to the wall.

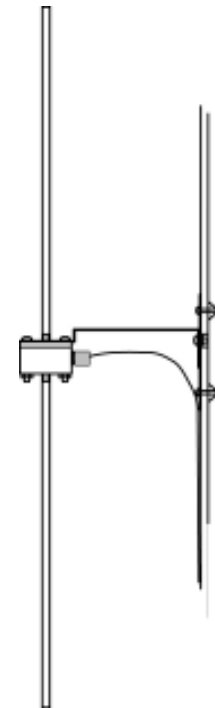

Diagram C. A direct Wall Mount should use the Mounting Plate for added strength, but it is not required for proper antenna operation.

Mounting Inside a Wall or Ceiling

See *Diagrams D and E*

The antenna may be hidden inside a wall or ceiling. **IMPORTANT:** Do not install the antenna inside a metal wall or ceiling, as this would obstruct the signal.

You will use a flexible dipole (the floppy wires) in this configuration. Select the correct wires for your configuration (72 MHz or 216 MHz). Connect one antenna wire to the ground side of the Antenna Module using one of the Hex Kep nuts provided. Connect the other wire to the active side using the other Hex Kep nut, as noted in Diagram D below. If you are using a Mounting Bracket, you will need to install the provided fiber washer between the antenna and mounting bracket.

Secure the mounting bracket to a beam, making sure the active (non grounded) side of the antenna is directed toward the area where the receivers will be located (see Diagram E below). Then, secure the ends of the antenna to beams using wood screws or the provided sheet metal screws. Try to make the wires as straight as possible, and make sure they extend in opposite directions.

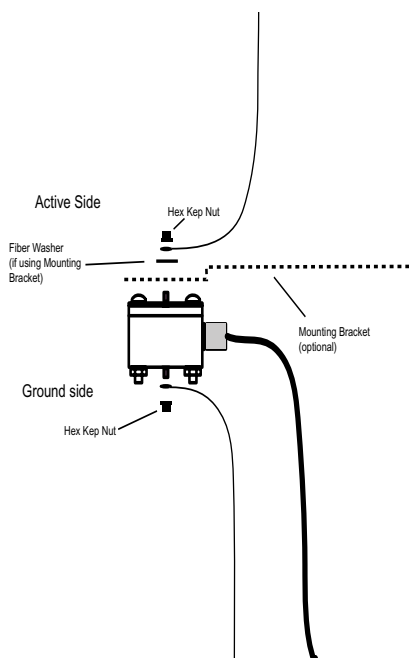

Diagram D. Flexible Dipole connection to the Antenna Module.

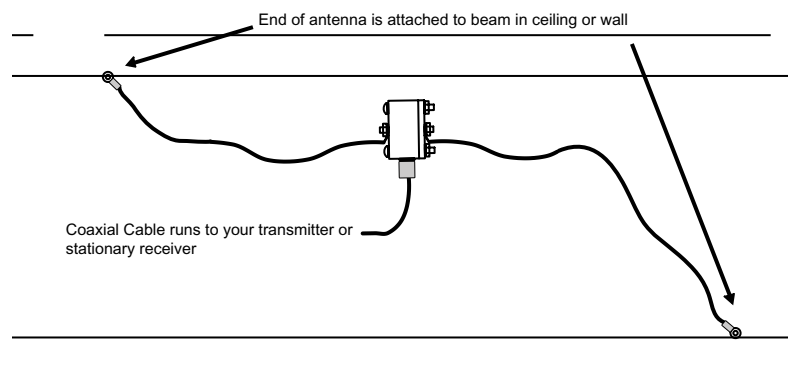
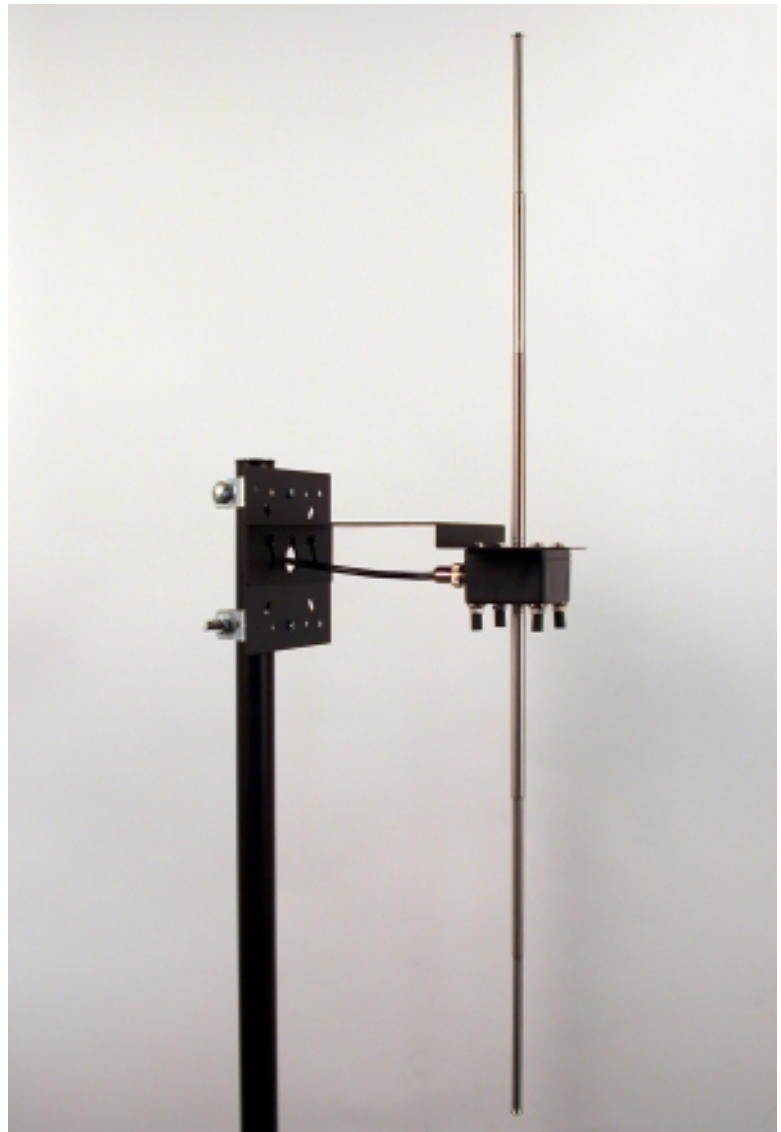

Diagram E. A flexible dipole can be mounted in your ceiling or wall as shown here. Although the Mounting Bracket is not shown here, it would be used to secure the Antenna Module to a beam.

Mounting to a Mast or Conduit

The antenna may be mounted to a mast, pole or section of vertical conduit. A mast made of non-conductive material works best; however, if you must use a metal mast, be sure to orient the antenna mount so the mast is not between the antenna and the designated receiving area.

The Mounting Plate is not required, but will provide a stronger mount for the antenna. Secure two commercially available conduit clamps (not included in this kit) to the mast, then attach the Mounting Plate to the clamps and connect the Mounting Bracket to the Mounting Plate, as shown in the photo at right.



Installation of a dipole antenna on a vertical mast with the Mounting Plate. Note that the antenna is installed at the TOP of the mast.

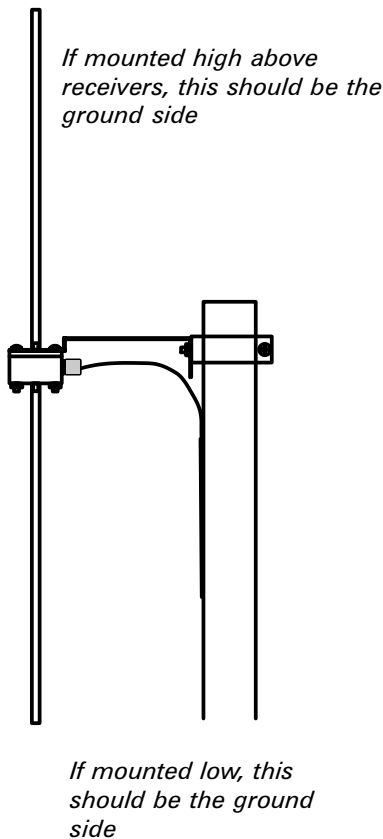

Diagram F. Mast Mount without the Mounting Plate.

IMPORTANT (see Diagram F at left): When installing an antenna on a metal mast, make sure the mast does not extend above the antenna module. If you are mounting the antenna in a high location (such as a stadium), the active element should be at the bottom. If mounted low, the active element will be at the top of the installation. Make sure the antenna is mounted in such a way that the mast will not interfere with the signal.

Connecting the Dipole Antenna

You have two choices of antenna with the dipole option: the rigid dipole, which has the two extendable arms, or the flexible dipole, which has the "floppy" wires with securing rings at the ends. Rigid dipole pieces screw onto the connectors at the top and bottom of the Antenna Module. Flexible dipole wires are secured using Hex Kep nuts and a fiber washer as indicated on page 9.

If you don't have enough room to fully extend the ground arm of a rigid dipole, you can use half of a rigid dipole for the active side and half of a flexible dipole for the ground side. Although the dipole works best when the wires are fully extended straight, satisfactory operation can still be obtained when you slightly bend the ground wire (not the active one!) to fit around a ceiling or floor corner.

Connect the coaxial cable (either the cable provided in the kit or your own) to the Antenna Module's BNC connector. Connect the other end to the LT-800 transmitter or the LR-100 Receiver / Power Amplifier, depending on which device you are using.

If you supply your own cable, you **MUST** use 50 Ohm coaxial cable and connectors. **Do not use cable made for cable TV installations;** it is rated at 75 Ohms and will not work in this application.

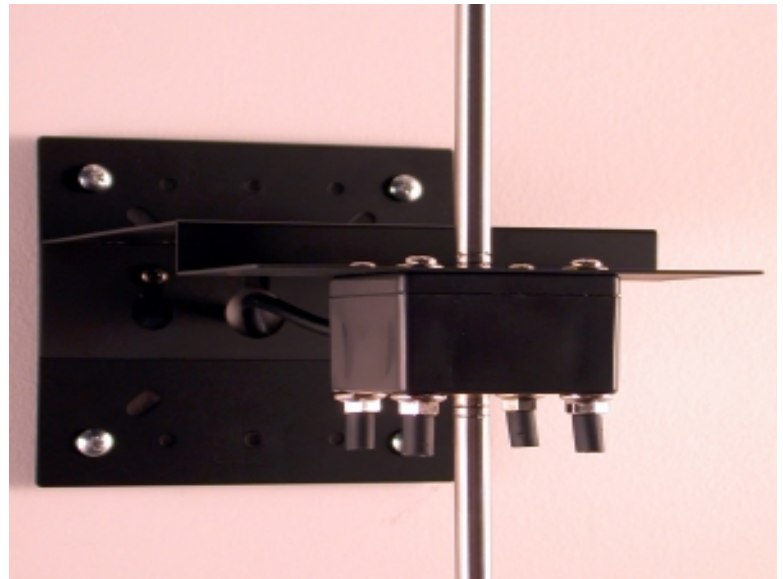

Rigid dipole sections screw onto the opposite sides of the antenna module, and are then fully extended.

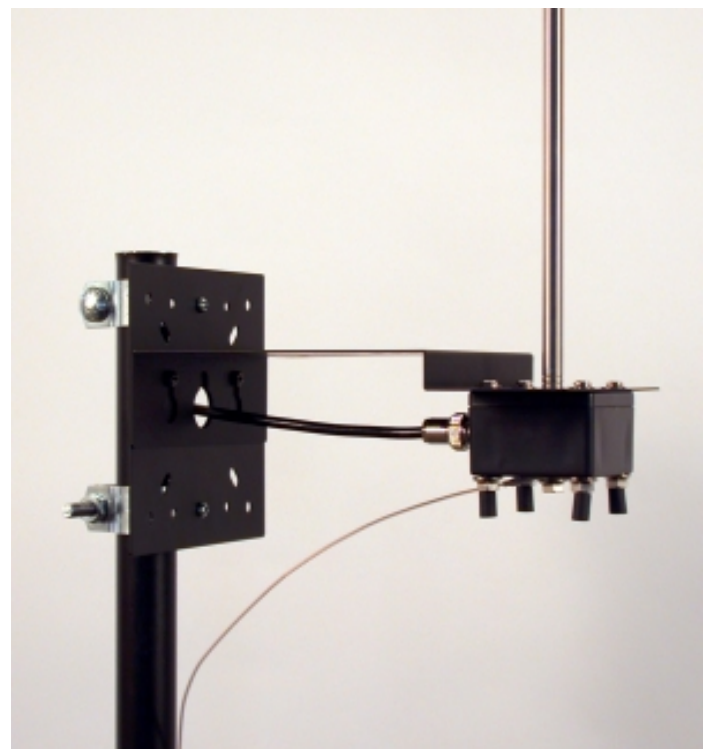

Using half of a flexible dipole for grounding a rigid dipole. This is a good choice when you don't have room to fully extend the ground side of the dipole.

Monopole Antenna Mounting Options

Mount to a Grounded Electrical Box, Ceiling or Floor

A monopole (single element) antenna may be mounted to a grounded light box or junction box in a ceiling or floor using the Mounting Plate and Mounting Bracket.

BEFORE STARTING, reverse the Antenna Module on the Mounting Bracket, then install the Hex Kep nut on the ground post (see Diagram G at right). The combination of the Mounting Bracket, nut and your grounded electrical box provides the required ground for the antenna.

If you do not have access to a grounded box, you will need to attach a flexible antenna element to the ground side of the Antenna Module (see Diagram I). Be sure to use the correct length element (longer wire for 72 MHz, shorter one for 216 MHz). Connect the wire underneath the shorting nut and run it up into the ceiling.

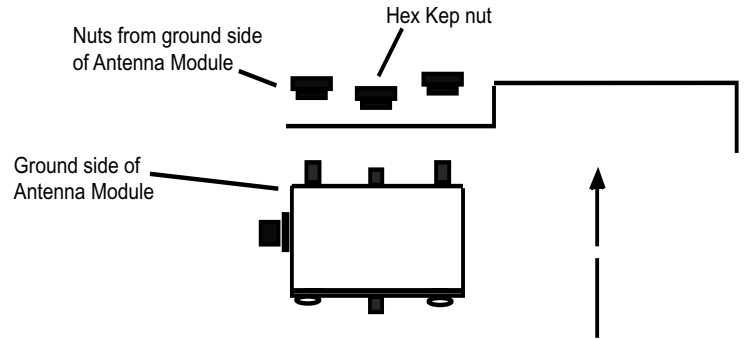

Diagram G. Reversing the Antenna Module on the Mounting Bracket.

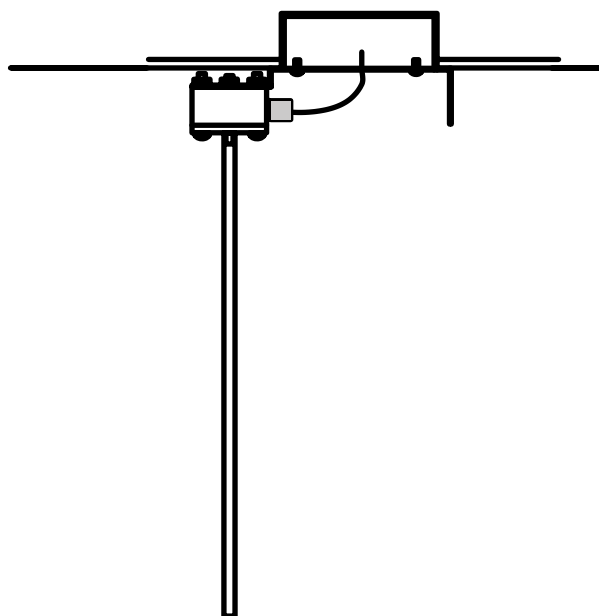

Diagram H. Ceiling mounted monopole with a grounded box.

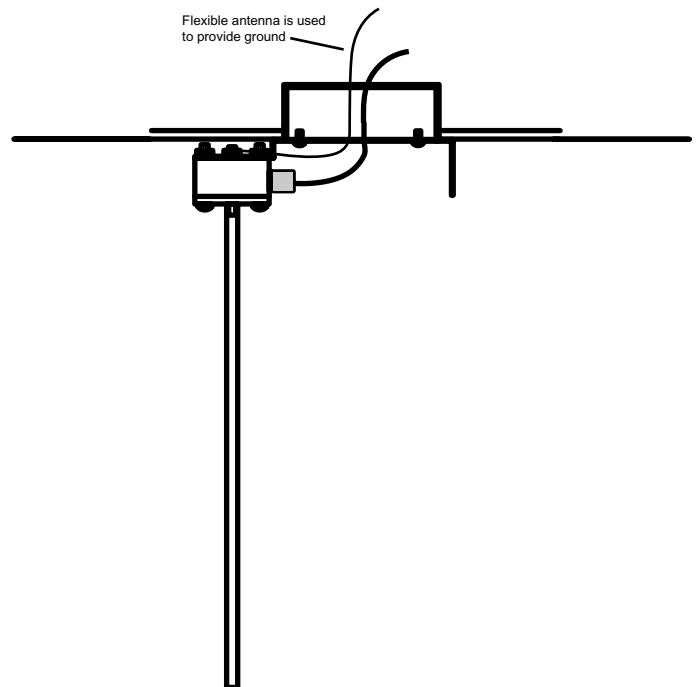

Diagram I. Ceiling mounted monopole with a flexible antenna attached to provide a ground. This installation creates a dipole antenna, which has better performance than a monopole. The Shorting Plate is not used in this configuration.

Mount to a Metal Surface Using the Ground Plane and Shorting Plate

See *Diagram J*

It is often convenient to place an antenna on top of a metal equipment rack. In order for the antenna to function properly, it must be secured to the equipment rack using the Grounding Plate and Grounding Base.

The Mounting Bracket is not used in this configuration. Remove the four nuts and screws from the Antenna Module and carefully remove it from the bracket. With a lockwasher still over each screw, put the screws through the Ground Plane. Make sure the ground side of the Antenna Module (as indicated on the module) is oriented AWAY from the Grounding Plane. Then, slide the Shorting Plate over the ground side (bottom) of the module. Replace the four nuts on the bottom of the assembly. Then, place a Hex Kep nut on the center ground post and tighten.

Secure the Ground Plane to your metal rack using sheet metal screws.

Attach the proper Monopole antenna element to the Antenna Module. Systems on 72 MHz will use the LONGER antenna; systems on 216 MHz will use the SHORTER one.

Connect the supplied coaxial cable between the Antenna Module and the stationary transmitter or receiver. If you use your own coaxial cable, be sure to use cable and connectors rated at 50 Ohms.

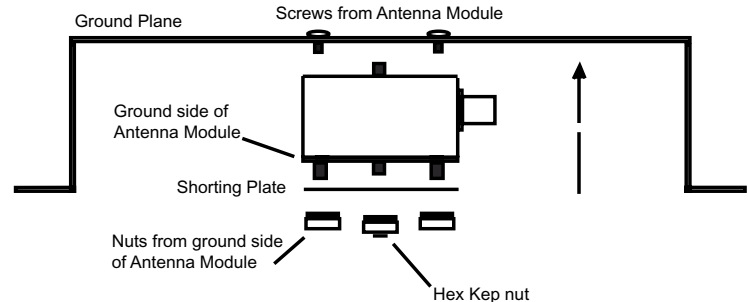

Diagram J. A reversed Antenna Module with Ground Plane and Shorting Plate.

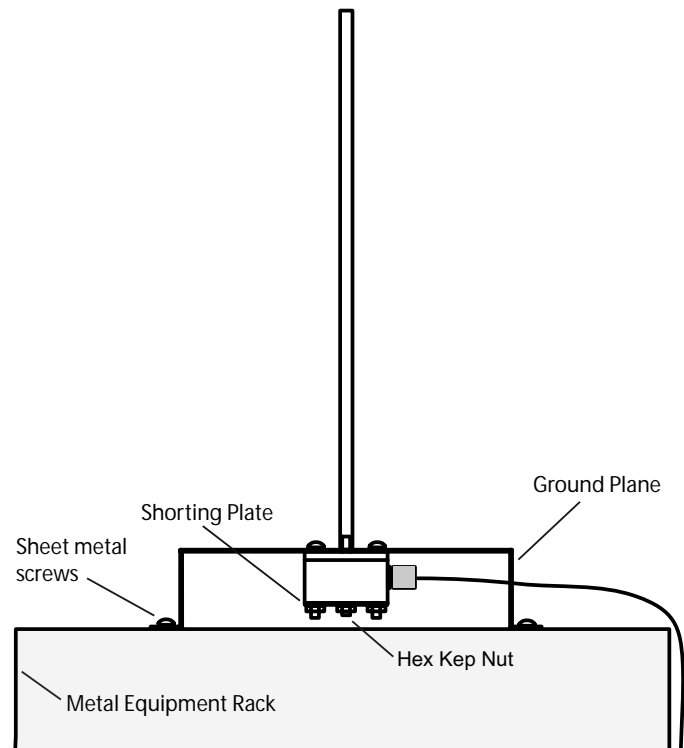

Diagram K. Mounting a Monopole on a metal surface.

Mounting a Monopole Antenna to a Metal Beam or Metal Ceiling

See *Diagram K*

Follow the instructions for mounting to a metal equipment rack, orienting the antenna downward rather than upward.

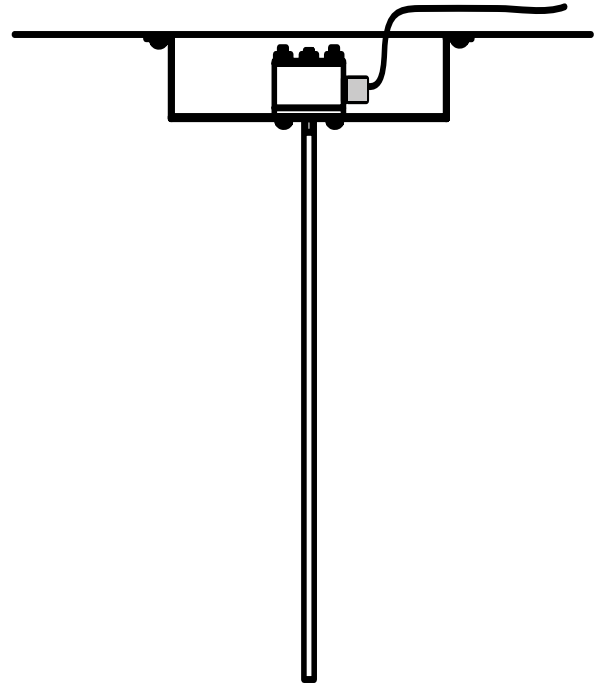

Diagram K. Inverse mounting of a monopole.

Mounting a Monopole Antenna to a Non-Conductive Surface

See *Diagram L*

Follow the instructions for mounting to a metal equipment rack, however, there are two additional steps:

1. Connect a length of flexible antenna (appropriate to the frequency you are using) on the ground post of the antenna module under the Hex Kep nut. You will NOT use the shorting plate in this configuration.
2. Drill a hole in the non-conductive surface and run the flexible antenna through the hole. This antenna will provide the ground for your antenna since the non-conductive surface cannot supply a ground.

If you are mounting the monopole upside down on a ceiling, run the flexible length inside the ceiling and stretch it out as far as possible from the monopole antenna element. Secure the antenna through the connection lug at the end of the wire.

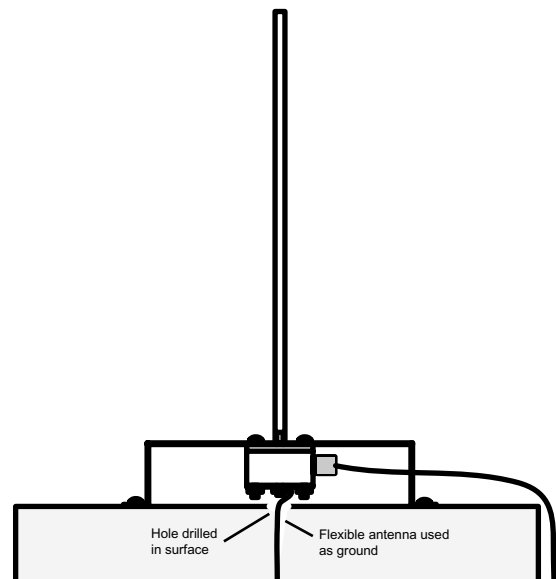

Diagram L. Mounting a monopole on a non-conductive surface. Use of the flexible wire creates a dipole, which is a better antenna than the monopole.

Troubleshooting

I'm not hearing anything in my receiver.

1. Make sure the receiver's batteries aren't dead, that it is turned on, set to the right channel, and the volume has been turned up.
2. Make sure your transmitter or stationary receiver has been powered up and set to the right channel, and the desired audio has been applied.
3. Make sure the coaxial cable has been tightly attached to both the antenna and the transmitter / stationary receiver.
4. Make sure you have used 50 ohm coaxial cable.
5. Make sure the antenna element(s) has been securely attached to the Antenna Module.

I'm getting a signal, but it isn't very strong.

1. Make sure you are using the correct antenna element(s) for your operating band (72 MHz or 216 MHz). Antennas for 72 MHz are longer than those used for 216 MHz.
2. If you are using a dipole antenna, make sure both elements are securely attached to the Antenna Module and that they have been fully extended in opposite directions.
3. If you are using a monopole antenna, make sure it has been grounded with either the grounding plate / grounding base or a flexible antenna attached to the grounding post on the Antenna Module.
4. Make sure the active element of the antenna is directed toward the area where the receivers are being used and that the ground side is directed AWAY from the receive area.
5. Make sure the antenna has been placed in an area free of metal obstructions.
6. Check the operating power of your transmitter - there are three settings, 1/4, 1/2 and full power. Increase the power if it's low.

My signal is strong but it is distorted.

1. Make sure your transmitter or stationary receiver is on the same channel as the receivers.
2. Make sure you are not too close to the antenna.
3. Lower the level of the audio signal being fed into the transmitter.

If you are still having problems after checking the above items, call Listen for help. We are available from 8 AM to 5 PM Mountain time, Monday through Friday, at 1.800.330.0881 or 801.233.8992, or you can e-mail us at support@listentech.com. Our full contact information is available on page 1 of this manual.

Warranty

Listen Offers a Limited Lifetime Warranty, Including a Performance Guarantee.

Listen Technologies Corporation (Listen) warrants its transmitters and receivers (LT-700, LT-800, LR-100, LR-300, LR-400, LR-500, LR-600, etc.) to be free from defects in workmanship and material under normal use and conditions for the useful lifetime of the product from date of purchase. All other products and accessories are warranted for ninety days from date of purchase. This warranty is only available to the original end purchaser of the product and cannot be transferred. Warranty is only valid if warranty card has been returned within 90 days of purchase. This warranty is void if damage occurred because of misuse or if the product has been repaired or modified by anyone other than a factory authorized service technician. Warranty does not cover normal wear and tear on the product or any other physical damage unless the damage was the result of a manufacturing defect. Listen is not liable for consequential damages due to any failure of equipment to perform as intended. Listen shall bear no responsibility or obligation with respect to the manner of use of any equipment sold by it. Listen specifically disclaims and negates any warranty of merchantability or fitness of use of such equipment including, without limitation, any warranty that the use of such equipment for any purpose will comply with applicable laws and regulations. The terms of the warranty are governed by the laws of the state of Utah.

Listen will only accept returned products with prepaid shipping and with a return authorization number. To receive a return authorization number call 1.800.330.0891 or +1.801.233.8992. Listen will refund the purchase price of the product to the original purchaser within the first ninety days after purchase if the product does not perform better than a similar competitive product subject to an annual amount to any one original purchaser not to exceed \$1,000 and subject to the conditions of this limited warranty. This is called our "Whatever-it-takes Performance Guarantee." To receive a refund, call Listen for a return authorization number. Refunds will only be given to the original purchaser of product once the product has been returned to the factory in good working order with an explanation for the refund. Return the product with a letter on the end user's letterhead stating the reason for the refund and a copy of the original invoice. If the product was purchased through a dealer, refunds must be processed through the original dealer.

In the first ninety days after purchase, any defective product will be replaced with a new unit. After ninety days, Listen will, at its own discretion, either replace transmitters and receivers with a new unit or a unit of similar type and condition. Product that is not covered under warranty can be replaced with a unit of similar type and condition based on a flat fee. Contact Listen for details.

This limited warranty, prices and the specifications of products are subject to change without notice. Visit www.listentech.com or contact Listen at the address shown below.

Free Manuals Download Website

<http://myh66.com>

<http://usermanuals.us>

<http://www.somanuals.com>

<http://www.4manuals.cc>

<http://www.manual-lib.com>

<http://www.404manual.com>

<http://www.luxmanual.com>

<http://aubethermostatmanual.com>

Golf course search by state

<http://golfingnear.com>

Email search by domain

<http://emailbydomain.com>

Auto manuals search

<http://auto.somanuals.com>

TV manuals search

<http://tv.somanuals.com>