



Lochinvar[®]
High Efficiency Water Heaters, Boilers and Pool Heaters



DESIGNER'S GUIDE COPPER-FIN[®] WATER HEATER

495,000 - 2,065,000 Btu/hr

Dear Specifier/Project Manager,

At Lochinvar, we have long recognized the importance of innovation to any product or service. Those who enter into business **must** also accept the challenge of meeting constantly changing needs.

The designer's guide you are now holding has been designed to make it more convenient for you to select the perfect Lochinvar water heater for your projects and provide correct specifications for your teams.

All information has been organized and presented in a succinct, easy-to-use manner, so you can use and share information confidently and with minimal effort.

However, it is important to remember that this guide is not intended to replace our installation manual. Installers should still refer to our installation manual for specific installation instructions.

We hope this manual will make your work easier and more productive. As always, we greatly appreciate your input on additional improvements for the future.

Thanks once again for specifying the Lochinvar family of quality standard and custom-built water heaters and boilers.

Sincerely,



Lochinvar Corporation

Table of Contents

Codes	2	TABLE A. Clearances From Combustible	3
Combustion & Ventilation Air	5	TABLE B. Flue Sizes	8
Contaminants	6	TABLE C. Outdoor Kits	10
Determining Total "Free Area"	5	TABLE D. Gas Supply Pipe Sizing	11
Electrical Requirements	14	TABLE E. Inlet Gas Pressure	11
Gas Supply	10	TABLE F. Required Temperature Rise	12
General Venting	6	TABLE G. Required Pump Performance	13
Location of Unit	2	TABLE H. Common Water Manifold Sizes	14
Low Water Temperature Delivery	12	TABLE I. Amp Draw	14
Outdoor Use	3		
Outdoor Installation	9		
Pump Operation	12		
Relief Valve	14		
Venting Options	8		
Water Connections	11		
Water Treatment	13		
Water Velocity Control	12		

Figures & Tables Index

FIG. 1 Models CW 495-2066 Requirements For Installation Over Combustible Floor	3	Appendix A - Water Heater Piping Diagrams	
FIG. 2 Water Heater Equipment & Control Orientation	4	Single Heater – Single Tank	A1
FIG. 3-6 Combustion & Ventilation Air	5,6	Single Heater – Two Tanks	A2
FIG. 7 Barometric Damper Installation	8	Two Temperature Installation Single Heater – Single Tank	A3
FIG. 8 Multiple Unit Barometric Damper Installation	9	Two Heaters – Single Tank	A4
FIG. 9 Outdoor Venting	9	Two Heaters – Two Tanks	A5
		Multi-Stack Frame Two Heaters – Single Tank	A6

In designing a water heater system, pay special attention to:

○ Water Velocity

(See page 12 for Required Degree Rise chart.)

○ Factory Supplied Pump Capacity

(See page 12 for Pump Operation.)

○ Manifold Pipe Size

When using more than one heater
(See page 14 for Common Water Manifold Size for Multiple Water Heater Installation Table.)

○ Storage Tank Circulating Tappings

(See page 14 for Manifold Pipe Size.)

○ Placement of Cold Water Inlet and Building Return

(See Appendix A for Water Heater Piping Diagrams.)

○ Water Hardness

(See page 13 for Water Treatment Information.)

CODES

The equipment shall be installed in accordance with those installation regulations in effect in the local area where the installation is to be made. These shall be carefully followed in all cases. Authorities having jurisdiction shall be consulted before installations are made.

In the absence of such requirements, the installation shall conform to the latest edition of the *National Fuel Gas Code, ANSI Z223.1*. Where required by the authority having jurisdiction, the installation **must** conform to *American Society of Mechanical Engineers Safety Code for Controls and Safety Devices for Automatically Fired Boilers, ASME CSD-1*. Where required by the authority having jurisdiction, the installation **must** comply with the *Canadian Association Code, CAN/CGA-B149.1 and/or B149.2* and/or local codes.

LOCATION OF UNIT

- 1.** Locate the unit so that if water connections should leak, water damage will not occur. When such locations cannot be avoided, it is recommended that a suitable drain pan, adequately drained, be installed under the unit. The pan **must** not restrict combustion air flow.

Under no circumstances is the manufacturer to be held responsible for water damage in connection with this unit or any of its components.

2. The indoor units **must** be installed so that the ignition system components are protected from water (dripping, spraying, rain, etc.) during appliance operation and service (circulator replacement, control replacement, etc.).

3. The appliance **must** be installed on a level, non-combustible floor. Concrete over wood is not considered a non-combustible floor. Maintain required clearances from combustible surfaces.

4. For installation on a combustible floor only when installed on special base: Units installed over a combustible floor **must** use the Special Combustible Floor Base. The unit **must** be centered on the base as shown in FIG. 1.

- Provide a base of hollow clay tile or concrete blocks from 8" to 12" thick and extending 24" beyond the sides.
- The blocks **must** be placed in line so that the holes line up horizontally to provide a clear passage through the blocks.

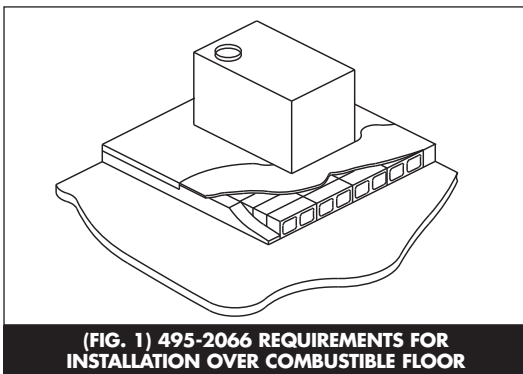

(FIG. 1) 495-2066 REQUIREMENTS FOR INSTALLATION OVER COMBUSTIBLE FLOOR

• **This procedure should also be followed if electrical conduit or radiant heat distribution piping runs through the floor and beneath the appliance.**

- Ensure that combustible floor base meets local fire code requirements.

5. Outdoor models require the installation of an optional vent cap. Instructions for placement of the vent cap are included in the venting section.

Outdoor models **must** not be installed directly on the ground. The outdoor unit **must** be installed on a concrete brick, block or other non-combustible pad.

(TABLE A) – CLEARANCES FROM COMBUSTIBLE CONSTRUCTION	
CLEARANCES	CW495-2066
Right Side	3"
Rear	3"
Left Side	3"
Front	(24" for Service) ALCOVE* (30" for Service)
Top	3"
Flue	1"***

* Alcove is a closet without a door.
** Consult local codes and/or vent material manufacturer.

SPECIAL LOCATION: OUTDOOR USE

Outdoor models have additional location and clearance requirements. These requirements **must** be adhered to carefully, since wind, rain, snow and cold cannot be controlled in outdoor applications. See **Outdoor Installation**, on page 9.

Lochinvar

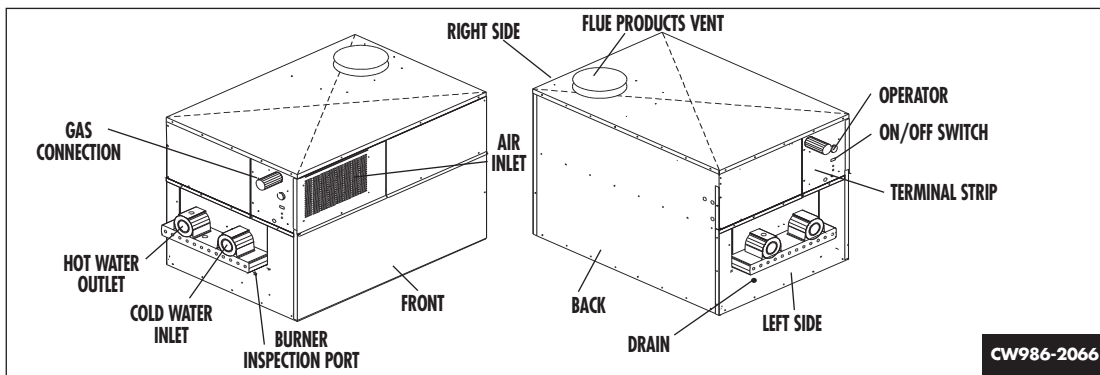
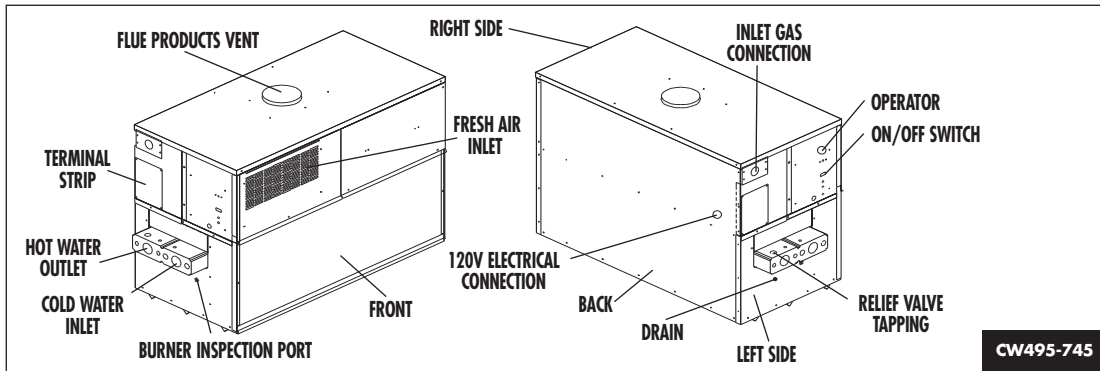

(FIG. 2) WATER HEATER EQUIPMENT AND CONTROL ORIENTATION.

COMBUSTION & VENTILATION AIR

Provisions for combustion and ventilation air **must** be in accordance with Section 5.3, Air for Combustion and Ventilation, of the latest edition of the *National Fuel Gas Code, ANSI Z223.1*; in Canada, the latest edition of *CGA Standard B149 Installation Code for Gas Burning Appliances and Equipment*; or applicable provisions of the local building codes.

The equipment room **must** be provided with properly sized openings to assure adequate combustion air and proper ventilation when the unit is installed with conventional venting or sidewall venting.

CAUTION: Under no circumstances should the equipment room be under a negative pressure when atmospheric combustion equipment is installed in the room.

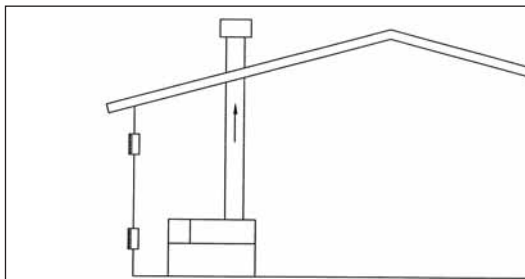

(FIG. 3) COMBUSTION AIR DIRECT FROM OUTSIDE

1. If air is taken directly from outside the building with no duct, provide two permanent openings:

A. Combustion air opening with a minimum free area of one square inch per 4000 Btu input (5.5 cm² per kW).

This opening **must** be located within 12" (30 cm) of the bottom of the enclosure.

B. Ventilation air opening with a minimum free area of one square inch per 4000 Btu input (5.5 cm² per kW). This opening **must** be located within 12" (30 cm) of the top of the enclosure.

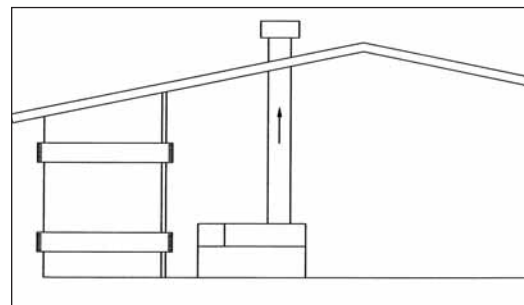

(FIG. 4) COMBUSTION AIR THROUGH DUCTWORK

2. If combustion and ventilation air is taken from the outdoors using a duct to deliver the air to the mechanical room, each of the two openings should be sized based on a minimum free area of one square inch per 2000 Btu input (11 cm² per kW).

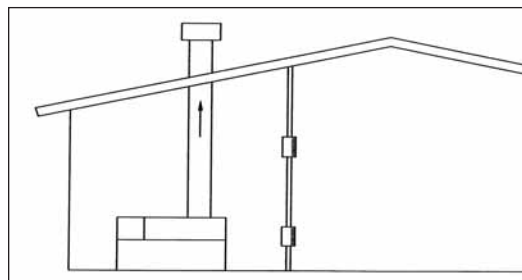

(FIG. 5) COMBUSTION AIR FROM AN INTERIOR SPACE

3. If air is taken from another interior space, each of the two openings specified above should have a net free area of one square inch for each 1000

EXAMPLE OF SIZING FOR COMBUSTION & VENTILATION AIR OPENINGS (WATER HEATER WITH 2,065,000 Btu/hr INPUT):

When combustion and ventilated air is taken from directly outside the building (FIG. 4), divide the total BTU's by 4,000. This yields 516.25 sq.in. of "Free Area" without restriction.

$$(2,065,000 \div 4000 = 516.25 \text{ sq.in.})$$

Since the air opening is 50% closed due to screens and louvers, the total opening must be multiplied by 2.

$$(516.25 \text{ sq. in.} \times 2 = 1,032 \text{ sq.in.})$$

This project requires one Ventilation Air Opening with net "Area" of 1,032 square inches with louver dimensions of 30" x 35" and one Combustion Air Opening with net "Area" of 1,032 square inches with louver dimensions of 30" x 35".

Btu (22 cm² per kW) of input, but not less than 100 square inches (645 cm²).

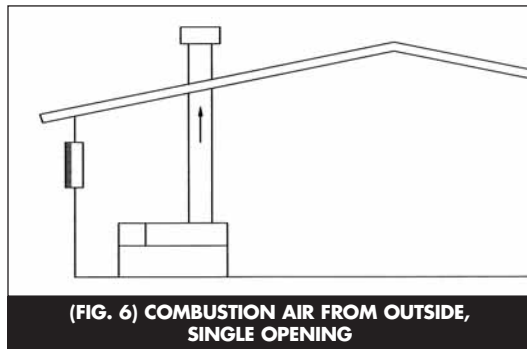

- 4. If a single combustion air opening is provided to bring combustion air in directly from the outdoors,** the opening **must** be sized based on a minimum free area of one square inch per 3000 Btu input (7 cm² per kW). This opening **must** be located within 12" (30 cm) of the top of the enclosure.

CAUTION!

EXHAUST FANS:

Any fan or equipment which exhausts air from the equipment room may deplete the combustion air supply and/or cause a down draft in the venting system. If a fan is used to supply combustion air to the equipment room, it must be sized such to make sure that it does not cause drafts which could lead to nuisance operational problems with the water heater.

CONTAMINANTS

Combustion air drawn from an interior or exterior space **must** be free of any chemical fumes which could be corrosive to the water heater. Burning chemical fumes results in the formation of corrosive acids which attack the water heater, cause improper combustion and premature failure of the water heater and vent.

These fumes are often present in areas where refrigerants, salts, and solvents are used. Therefore, be aware of swimming pool equipment, water softening, and cooling system placement.

VENTING

General

Copper-Fin II Water Heaters are classified as Category I appliances when tested to the latest ANSI Standard. This classification requires all conventionally vented combustion products to be vented using Category I listed vent pipe.

Additionally, it is recommended that this vent material be double wall construction or insulated in the field. A Category I appliance operates with a non-positive static vent pressure and with flue loss greater than 17 percent.

Vent installations for connection to gas vents or chimneys **must** be in accordance with Part 7, "Venting of Equipment," of the latest edition of the *National Fuel Gas Code, ANSI Z223.1*, or applicable provisions of the local building codes.

The connection from the appliance vent to the stack **must** be as direct as possible and sized correctly. The horizontal breeching of a vent **must** have at least 1/4" rise per linear foot. The horizontal portions should also be supported for the design and weight of the material employed to maintain clearances, prevent physical damage and separation of joints.

The connection from the appliance vent to the stack or vent termination outside the building **must** be made with listed

Category I double wall vent (or equivalent) connectors and sized according to vent sizing tables (FAN column) in the latest edition of the *National Fuel Gas Code*.

The Category I vent and accessories, such as firestop spacers, thimbles, caps, etc., **must** be installed in accordance with the vent manufacturer's listing. The vent connector and firestop **must** provide correct spacing to combustible surfaces and seal to the vent connector on the upper and lower sides of each floor or ceiling through which the vent connector passes.

Any improper operation of the common venting system in an existing building should be corrected when new equipment is installed, so the installation conforms to the latest edition of the *National Fuel Gas Code*, ANSI Z223.1.

When resizing any portion of the common venting system, it should be resized to approach the minimum size as determined using the appropriate tables in the *National Fuel Gas Code*.

The weight of the venting system **must** not rest on the water heater. The venting system **must** be adequately supported in compliance with local codes and other applicable codes.

Vent Terminations

The vent terminal should be vertical and exhaust outside the building at least 2 feet (0.6 m) above the highest point of the roof when within a 10 foot (3.05 m) radius.

Additionally, vertical terminations **must** be a minimum of 3 feet (0.9 m) above the roof line, and when less than 10 feet (3.05 m) from a parapet wall **must** be a minimum of 2 feet (0.61 m) higher than the parapet wall.

Vent caps should have a minimum clearance of 4 feet (1.2 m) horizontally from, and in no case above or below [unless a 4 feet (1.2 m) horizontal distance is maintained], electric meters, gas meters, regulators and relief equipment.

Maintain a distance of at least 3 feet (0.9 m) above any forced air inlet within 10 feet (3.05 m) and a distance of at least 4 feet (1.2 m) below, 4 feet (1.2 m) horizontally from, or 1 foot (30 cm) above any door, window or gravity air inlet.

Do not terminate the vent in a window well, stairwell, alcove, courtyard or other recessed area. **The vent can not terminate below grade.** The bottom of the vent terminal shall be located at least 12 inches (30 cm) above grade and clear of snow, ice, leaves or other debris.

The distance of the vent terminal from adjacent public walkways, adjacent buildings, windows, and building openings

Lochinvar

NOTE:
A vent system should never be sized based only on the vent connection diameter of the appliance. For proper vent design and sizing, please consult the National Fuel Gas Code (ANSI Z223.1).

must be consistent with the *National Fuel Gas Code Z223.1* or in Canada, the latest edition of *CGA Standard B149 Installation Code for Gas Burning Appliances and Equipment*.

VENTING OPTIONS

Conventional Venting

A conventional venting system utilizes the natural buoyancy of the heated flue products to generate a negative draft. This draft forces flue products to rise vertically through a rooftop flue termination. The vent connection is made directly to the top of the unit and combustion air supplied from the mechanical room. Properly sizing vent material and the use of a barometric damper (when required) will lead to proper vent operation.

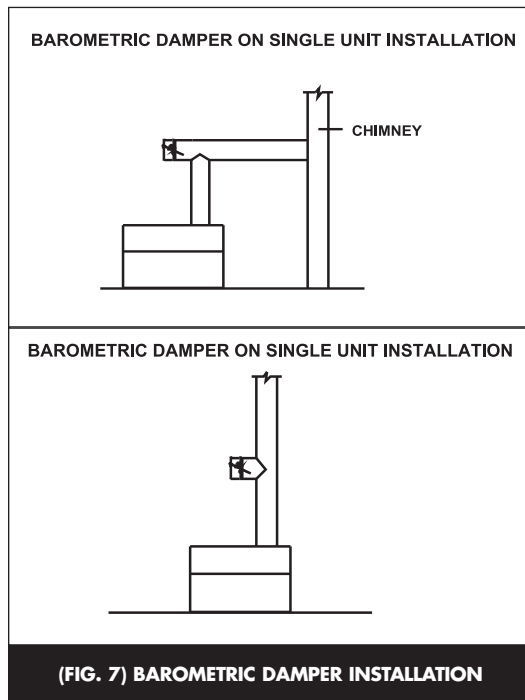

The minimum flue pipe diameters for Copper-Fin models, utilizing negative draft venting are as follows:

(TABLE B) FLUE SIZES AND COMBUSTION AIR PIPE SIZES	
MODEL NUMBER	FLUE SIZE
CW 495	6"
CW 645	8"
CW 745	8"
CW 986	10"
CW 1256	12"
CW 1436	12"
CW 1796	14"
CW 2066	14"

Size vent material using the "FAN" category of vent sizing tables in the latest edition of the *National Fuel Gas Code*. "FAN" applies to fan-assisted combustion appliances in Category I.

Barometric Dampers

A barometric damper is required when draft exceeds 0.08 inches of negative water column. When installed and adjusted properly, a barometric damper will maintain draft between 0.02 and 0.08 inches of negative water column ensuring proper operation.

Multiple unit installations with combined venting also require barometric dampers to regulate draft at each unit. Again, the negative draft **must** be within the range of 0.02 to 0.08 inches of negative water column to ensure proper operation.

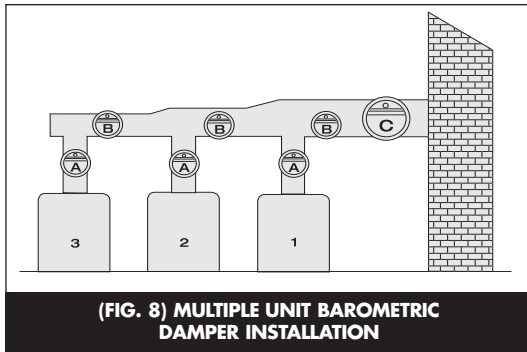

For this type of installation, it is best to use a draft control for each water heater located on the riser between the vent outlet and the breeching - Location "A". When this riser is too short to permit the installation of a draft control, locate a separate control for each water heater on the main breeching as illustrated in Location "B". If, because of general crowding or other reasons, neither of these locations are possible, use a single large control in the breeching between the water heater nearest the chimney and the chimney, as shown in Location "C".

All draft readings are made while unit is in stable operation (approximately 5 minutes running time).

Masonry Chimney

A masonry chimney **must** be properly sized for the installation of a high efficiency gas fired appliance. Exterior masonry chimneys, with one or more sides exposed to cold outdoor temperatures, are more likely to have venting problems. The temperature of the flue products from a high efficiency appliance may not be able to sufficiently heat the masonry structure of the chimney to generate proper draft. This will result in

condensing of flue products, damage of the masonry flue/tile, insufficient draft and possible spillage of flue products into an occupied living space.

Carefully inspect all chimney systems during the project design phase. If there is any doubt about the sizing or condition of a masonry chimney, it is prudent to reline the chimney with a properly sized and approved chimney liner system. Metallic liner systems (Type "B" doublewall or flexible or rigid metallic liners) are recommended. Consult with local code officials to determine code requirements or the advisability of using or relining a masonry chimney.

OUTDOOR INSTALLATION

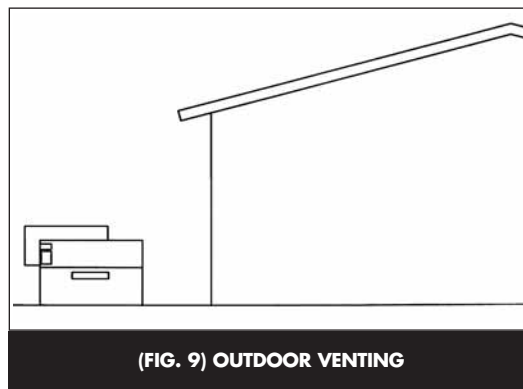

Units are self venting and can be used outdoors when installed with the optional Outdoor Cap. This cap mounts directly to the top of the water heater and covers the flue outlet and combustion air inlet openings on the jacket. No additional vent piping is required. Maintain a minimum clearance of 3" (76 mm) to combustible surfaces and a minimum of 3" (76 mm) clearance to the air inlet.

NOTE:
Common venting systems may be too large when an existing unit is removed. Be careful to resize any common venting system when new appliances are installed or existing appliances are replaced.

NOTE:
Flue gases will form a white plume in winter. Plume could obstruct window view. Flue gas condensate can freeze on exterior surfaces or on the vent cap. Flue gas condensate can cause discoloration of exterior building surfaces. Adjacent brick or masonry surfaces should be protected with a rust resistant sheet metal plate.

NOTE:
Venting of a high efficiency appliance into a cold or oversized masonry chimney can result in operational and safety problems.

Lochinvar

An outdoor unit should not be located so that high winds can deflect off of adjacent walls, buildings or shrubbery causing recirculation. Recirculation of flue products may cause operational problems, bad combustion or damage to controls. The unit should be located at least 3 feet (0.91 m) from any wall or vertical surface to prevent adverse wind conditions from affecting performance.

Multiple unit outdoor installations require 48" (1.22 m) clearance between each vent cap. The outdoor cap **must** be located 4 feet (1.22 m) below and 4 feet (1.22 m) horizontally from any window, door, walkway or gravity air intake.

The combustion air inlet of the outdoor cap **must** be located at least one foot (0.30 m) above grade and above normal snow levels. The water heater **must** be at least 10 feet (3.05 m) away from any forced air inlet and at least 3 feet (0.91 m) outside any overhang.

Do not install in locations where rain from building runoff drains will spill onto the water heater.

Lochinvar **must** furnish an outdoor vent kit in accordance with CSA international requirements. Each kit includes the flue outlet/combustion air inlet, assembly, gasket and pump cover.

(TABLE C) - OUTDOOR VENT KIT PART NUMBERS

MODEL NUMBER	PART NUMBER
CW 495	ODK3023
CW 645	ODK3024
CW 745	ODK3024
CW 986	ODK3046
CW 1256	ODK3047
CW 1436	ODK3047
CW 1796	ODK3048
CW 2066	ODK3048

Freeze Protection- Outdoor Installation

A snow screen should be installed to prevent snow and ice accumulation around the appliance or its venting system.

If for any reason the unit is to be shut off:

- (a.) Shut off water supply.
- (b.) Drain unit completely.
- (c.) Drain pump and piping.

If freeze protection is not provided for the system, a low ambient temperature alarm or automatic drain system is recommended.

GAS SUPPLY

- 1.** The gas pressure regulator supplied is for low pressure service. If upstream pressure exceeds 6 oz. (10.5" water column), an intermediate gas pressure regulator, of the lock up type, **must** be installed.
- 2.** The gas line should be a separate line direct from meter, unless the existing gas line is of sufficient capacity. Verify pipe size with your gas supplier.
- 3.** A trap (drip leg) should be provided in the inlet gas connection to the water heater.

4. A manual main gas shutoff valve is provided outside the jacket, upstream of the main gas valve.
5. In Canada, derated 10% from 2,000 - 4,500 ft., over 4,500 ft. derate **must** be in accordance with local authorities. Consult factory for installations at higher elevations.

High Altitude Applications

Atmospheric pressure decreases as the height above sea level increases. At any altitude above sea level, a cubic foot will contain less gas than a cubic foot at sea level. Thus, the heating value of a cubic foot of fuel gas will decrease as height above sea level increases.

Specific gravity of a gas with respect to sea level also decreases with altitude. These changes in heating value and specific gravity tend to offset each other.

However, as elevation above sea level is increased, there is less oxygen per cubic foot

of air. Therefore, heat input rate should be reduced in an appliance above 2000 feet. Ratings should be reduced at the rate of 4 percent for each 1000 feet above sea level.

(TABLE E) – INLET GAS PRESSURE		
MODELS	NAT. GAS	LP GAS
CW 495-745		
Minimum Allowable	4"	8"
Maximum Allowable	10.5"	13"
CW 986-2066		
Minimum Allowable	4.5"	8"
Maximum Allowable	10.5"	13"

WATER CONNECTIONS

Inlet and Outlet Water Connections

For ease of service, install unions on inlet and outlet of the water heater.

The connection on the unit marked "Inlet" should be used for return water from the storage tank. The connection on the header marked "Outlet" should be connected to the inlet of the storage tank. (See Appendix A for Water Heater Piping Diagrams).

EXAMPLE OF HIGH ALTITUDE APPLICATIONS

For example, if a unit's input is 100,000 Btu/hr at sea level, the rated input at 4000 feet of elevation can be calculated by derating input 4% per 1000 feet above sea level.

$$\begin{aligned}
 &[\text{Btu/hr Input}] \\
 &[1.00 - (\text{Elevation} / 1000 \\
 &\text{ft.} \times 0.04)] = \text{Btu/hr} \\
 &\text{Input at specified} \\
 &\text{elevation.} \\
 &[100,000][1.00 - (4000 \\
 &\text{ft.} / 1000 \text{ft.} \times 0.04)] \\
 &= \text{Btu/hr Input 4000'} \\
 &\text{elevation.} \\
 &[100,000][0.84] = \\
 &84,000 \text{ Btu/hr Input at} \\
 &4000 \text{ ft. elevation.}
 \end{aligned}$$

(TABLE D) – GAS SUPPLY PIPE SIZING

Nominal Iron Pipe Size, Inches ^{3/4}	Length of Pipe In Straight Feet													
	10	20	30	40	50	60	70	80	90	100	125	150	175	200
^{3/4}	369	256	205	174	155	141	128	121	113	106	95	86	79	74
1	697	477	384	328	292	267	256	246	210	200	179	164	149	138
1 1/4	1,400	974	789	677	595	543	502	472	441	410	369	333	308	287
1 1/2	2,150	1,500	1,210	1,020	923	830	769	707	666	636	564	513	472	441
2	4,100	2,820	2,260	1,950	1,720	1,560	1,440	1,330	1,250	1,180	1,100	974	871	820
2 1/2	6,460	4,460	3,610	3,100	2,720	2,460	2,310	2,100	2,000	1,900	1,700	1,540	1,400	1,300
3	11,200	7,900	6,400	5,400	4,870	4,410	4,000	3,800	3,540	3,300	3,000	2,720	2,500	2,340
3 1/2	23,500	16,100	13,100	11,100	10,000	9,000	8,300	7,690	7,380	6,870	6,150	5,640	5,130	4,720

Maximum capacity of pipe in thousands of BTU's per hour for gas pressures of 14" Inches Water Column (0.5 PSIG) or less and a total system pressure drop of 0.05 Inch Water Column (Based on NAT GAS, 1025 BTU's per Cubic Foot of Gas and 0.60 Specific Gravity).

LOW WATER TEMPERATURE DELIVERY

A number of water heating applications may require delivered water temperature in a system below 140°F. Systems such as nursing homes and hospitals would be examples of this type of system.

A water heating system that will be operated at less than 140°F **must** use a mixing valve on the outlet side of the storage tank in order to ensure that the products of combustion do not condense inside the combustion chamber of the water heater.

The mixing valve allows the water heater to operate above 140°F to protect from condensation, while still allowing a delivery of colder water to the system fixtures. Also inherent in this design is the protection of occupants from water containing bacteria such as Legionella. Legionella can be significantly reduced in the water storage vessel by heating the water to a minimum of 140°F. (See Appendix A for piping details.)

WATER VELOCITY CONTROL

IMPORTANT

To ensure proper velocity through the heat exchanger, it is necessary to regulate the temperature rise across the heat exchanger from inlet to outlet. (This **must** be done on initial installation and periodically rechecked).

With the correct temperature rise across the heat exchanger (See TABLE F), you may be

assured of the proper velocity in the tubes and long life and economical operation from the water heater.

(TABLE F) - REQUIRED TEMPERATURE RISE	
MODEL NUMBER	TEMPERATURE RISE °F
CW 495	15
CW 645	19
CW 745	22
CW 986	19
CW 1256	24
CW 1436	27
CW 1796	34
CW 2066	39

PUMP OPERATION

1. The water heater **MUST** be connected with a properly sized and installed, intermittent operating, all bronze pump that circulates water between heater and storage tank.
2. The pump is sized to heater input and water hardness. Should water hardness exceed 25 grains/350 TDS, consult factory for pump sizing.

The pump chart (TABLE H) is based on the following fittings:

6-90° elbows	2 ball valves
2 unions	1 cold water supply tee

Due to pump capacity the following specifications cannot be exceeded when using the standard pump:

- Not more than 45 feet of straight pipe.
- For every elbow and tee in excess of those shown above, DEDUCT 5 FEET from maximum allowable straight pipe in heater-to-tank circulating loop.

WATER TREATMENT

(TABLE G) – REQUIRED PUMP PERFORMANCE FOR WATER HARDNESS OF 5 TO 25 GRAINS					
MODEL	GPM	FT. HD	AMP DRAW	HORSE POWER	VOLTAGE/PHASE
CW 495-745	60	10	5.8	1/4	120/1
CW 986-2066	90	15	7.4	1/2	120/1

In hard water areas, water treatment should be used to reduce introduction of minerals into the system. Minerals in the water can collect in the heat exchanger tubes causing noise and inefficient operation. Excessive build-up of materials in the heat exchanger can cause a non-warrantable failure.

Acceptable Water Quality Levels

Maximum Water Hardness = 25 Grains

Minimum Water Hardness = 5 Grains

Maximum Total Dissolved Solids = 350 PPM

Range of Acceptable pH = 7.2 to 7.8

Standard production Lochinvar water heaters are designed to operate free of impurity build-up in the heat exchanger when properly installed and operated under the specified water quality conditions.

For installation in areas outside these parameters, please consult the factory.

Water Flow Switch

Due to the low water content (between 1 and 6 gallons) of the copper finned tube heat exchanger, a flow switch is factory installed as a low water cutoff device on models CW495 thru CW2066.

The flow switch is installed in the outlet piping from the water heater and wired in series with the ignition system safety controls.

In most localities, a flow switch is acceptable as a low water cutoff device on water heaters requiring forced circulation. It is prudent to verify acceptance with the local code official.

If the local water quality levels are slightly higher than recommended, it may be possible to use a copper-nickel heat exchanger. With copper-nickel being a harder alloy, flow rates can be safely increased to keep the greater water hardness and TDS in suspension. The flow rate can be increased up to 25% faster than the flow rates listed above.

NOTE:

A larger pump must be utilized in situations when the distance between the water and tank exceed those specified.

NOTE:

Care should be taken to measure temperature rise and maintain proper water velocity in the heat exchanger.

NOTE:

If a pressure reducing valve or check valve is in the system a properly sized expansion tank may be required.

Lochinvar

NOTE:
Incorrect piping of the cold water supply to the system will result in condensate formation on the heat exchanger and operational problems. Higher water temperatures reduce condensate formation. Refer to drawings in Appendix A.

Relief Valve

This water heater is supplied with temperature and pressure relief valve(s) sized in accordance with *ASME Boiler and Pressure Vessel Code, Section IV "Heating Boilers."*

(TABLE H) – COMMON WATER MANIFOLD SIZE FOR MULTIPLE WATER HEATER INSTALLATION

Pipe sizing chart provides minimum pipe size for common manifold piping to ensure adequate flow.

NUMBER OF UNITS	COMMON MANIFOLD SIZE (Min.)
CW 495 thru 745	
1	2"
2	3"
3	3 1/2"
4	4"
5	5"
6	5"
CW 986 thru 2066	
1	2 1/2"
2	4"
3	4"
4	5"
5	6"
6	6"

NOTE:
When the unit is installed in Canada, it must conform to the CAE C22.1, Canadian Electrical Code, Part 1, and/or local Electrical Codes.

ELECTRICAL REQUIREMENTS

(North America)

The appliance is wired for 120 volts.

- All wiring between the unit and field installed devices shall be made of type T wire [63°F (35°C) rise].
- The pump **must** be wired to run continuously when unit is firing.
- It is recommended that the water heater and pump be wired on separate circuits with properly sized breakers.

(TABLE I) – AMP DRAW DATA

MODEL NUMBER	FAN(S)	CONTROLS	PUMP	TOTAL AMPS w/PUMP
CW 495-745	3.4	4.6	5.8	13.8
CW 986-1256	3.4	4.6	7.4	15.4
CW 1436-2066	3.8	4.6	7.4	15.8

WATER HEATER PIPING DIAGRAMS APPENDIX A

PIPING DIAGRAM



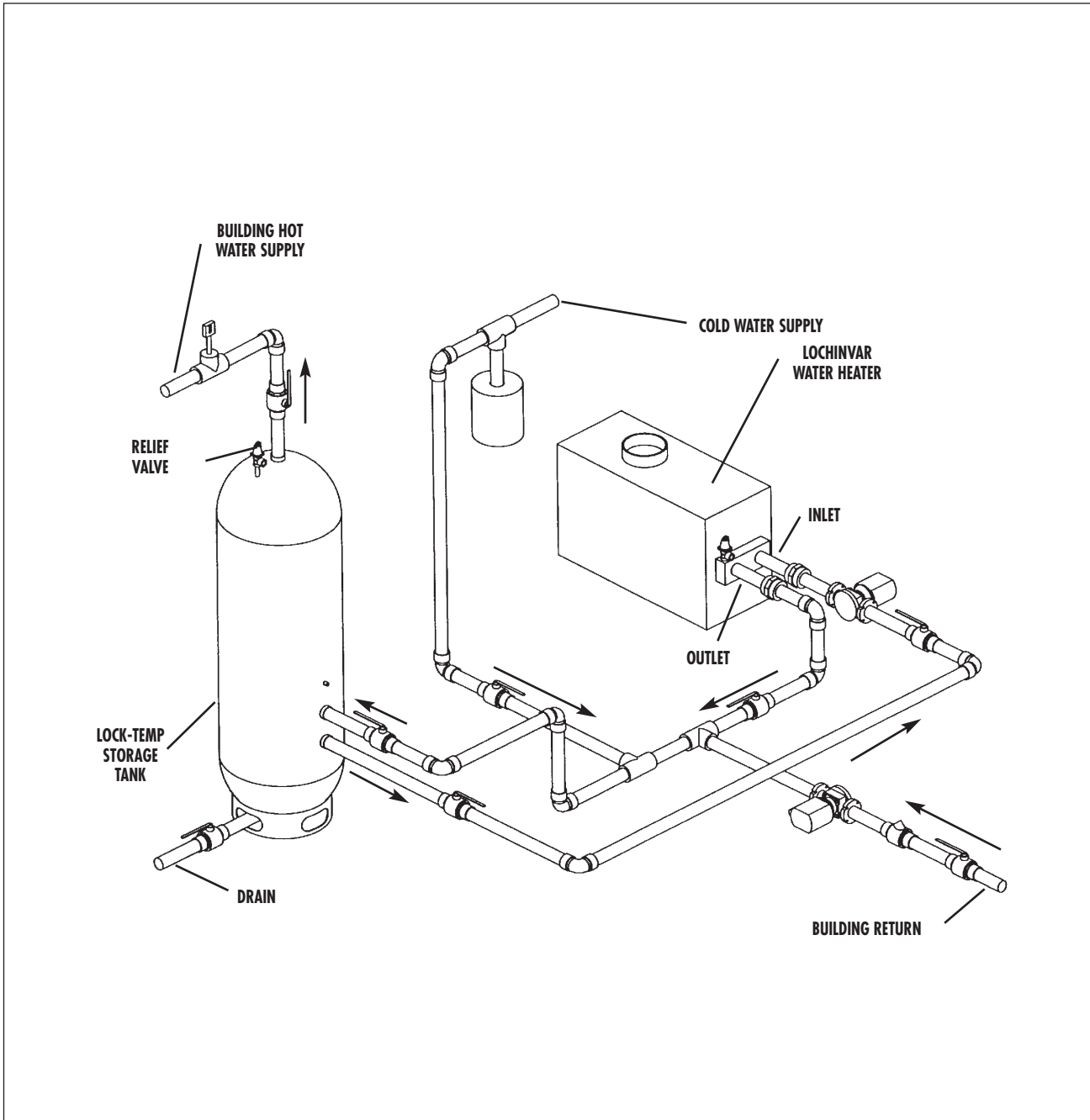





SINGLE HEATER - SINGLE TANK



This illustration is for concept only and should not be used for any actual installation without engineering or technical advice from a licensed engineer. All necessary equipment may not be illustrated.

LIT0133

LEGEND



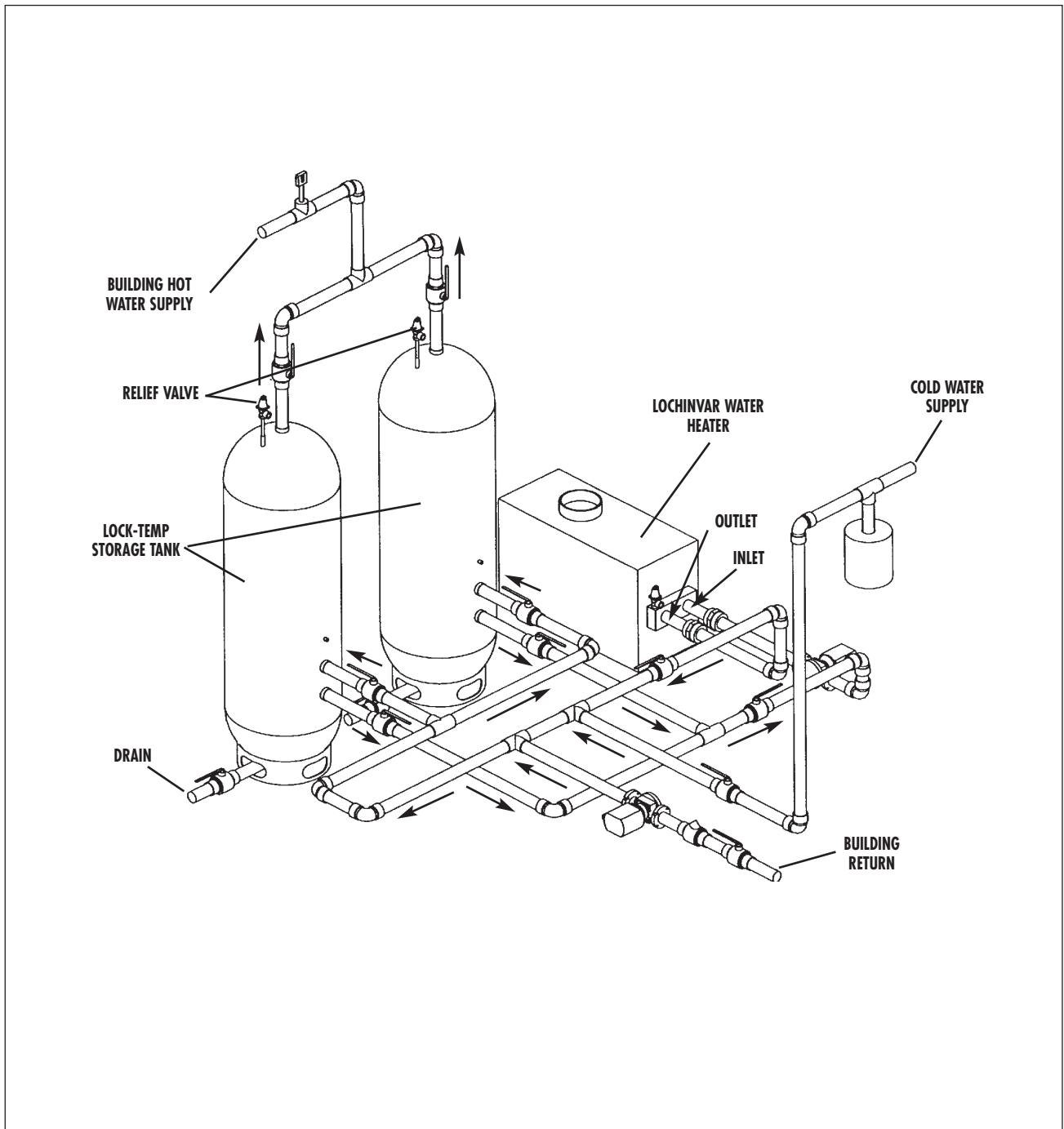





								
FULL PORT BALL VALVE	SYSTEM PUMP	SYSTEM RELIEF VALVE	TEE	ELBOW	UNION	EXPANSION TANK	CHECK VALVE	THERMOMETER



This illustration is for concept only and should not be used for any actual installation without engineering or technical advice from a licensed engineer. All necessary equipment may not be illustrated.

LIT0135

LEGEND



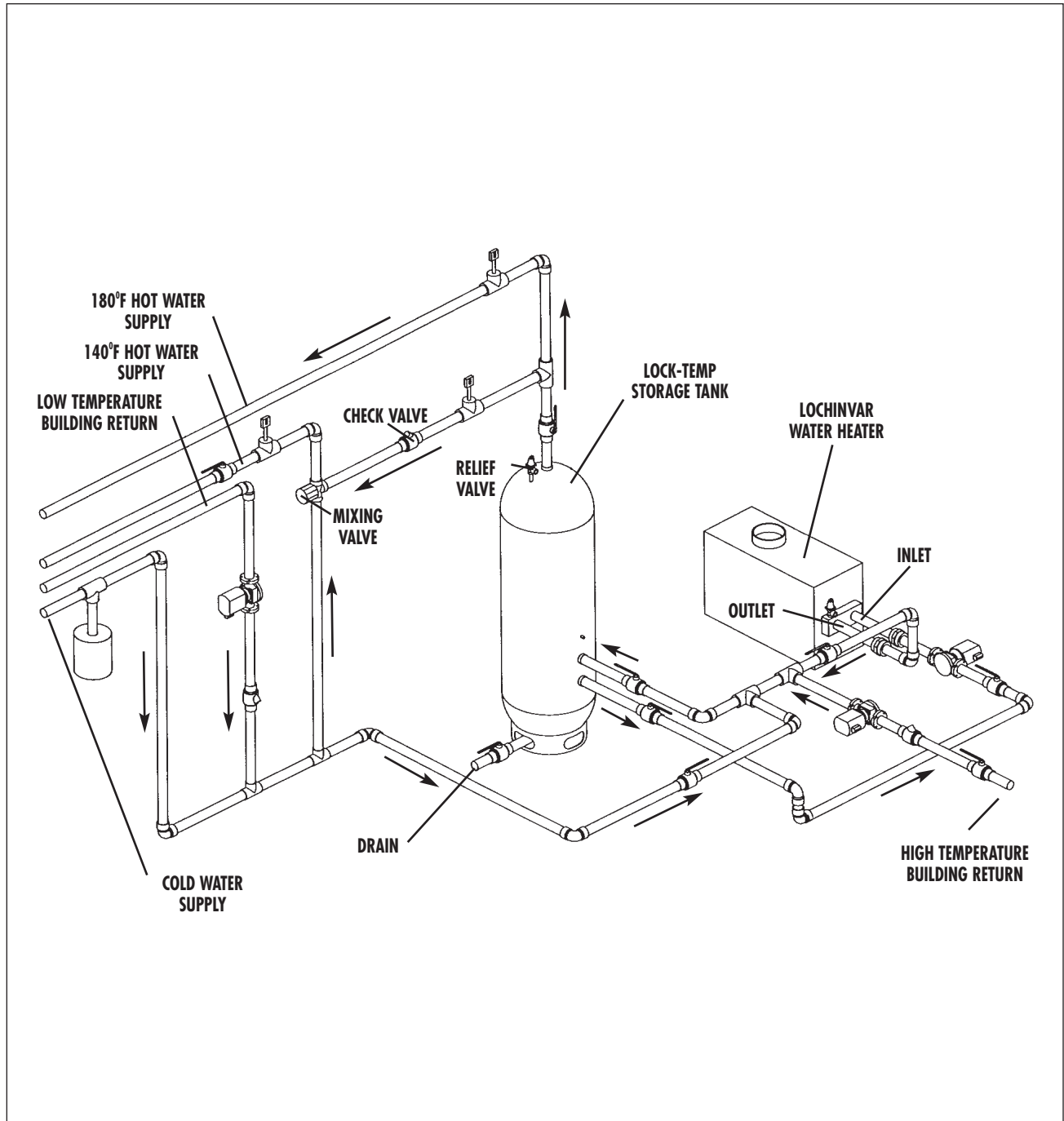





								
FULL PORT BALL VALVE	SYSTEM PUMP	SYSTEM RELIEF VALVE	TEE	ELBOW	UNION	EXPANSION TANK	CHECK VALVE	THERMOMETER



This illustration is for concept only and should not be used for any actual installation without engineering or technical advice from a licensed engineer. All necessary equipment may not be illustrated.

LIT0136

LEGEND

								
FULL PORT BALL VALVE	SYSTEM PUMP	SYSTEM RELIEF VALVE	TEE	ELBOW	UNION	EXPANSION TANK	CHECK VALVE	THERMOMETER

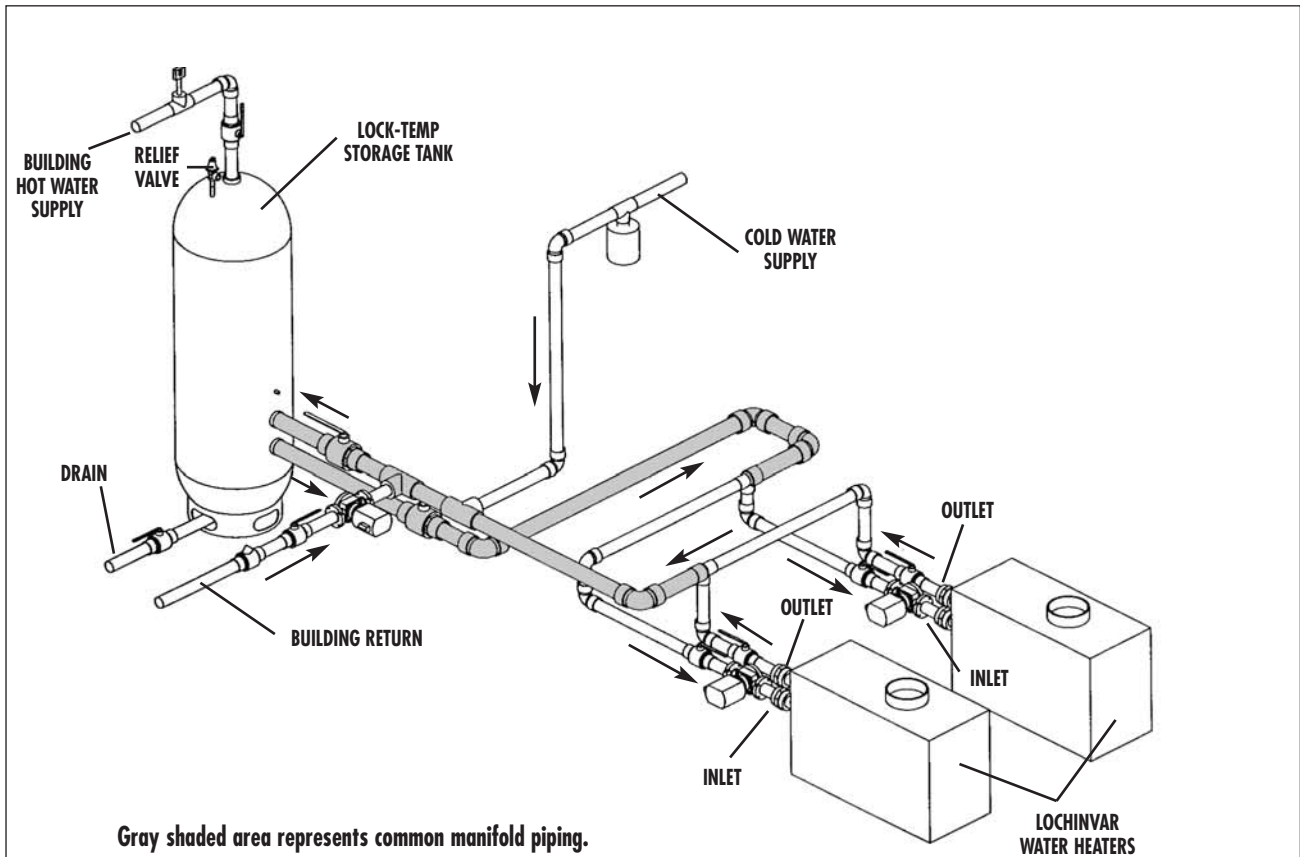

Gray shaded area represents common manifold piping.

COMMON WATER MANIFOLD SIZE FOR MULTIPLE WATER HEATER INSTALLATION			
<i>Pipe sizing chart provides minimum pipe size for common manifold piping to ensure adequate flow.</i>			
NUMBER OF UNITS	COMMON MANIFOLD SIZE (Min.)	NUMBER OF UNITS	COMMON MANIFOLD SIZE (Min.)
CW 495-745		CW 986-2066	
1	2"	1	2-1/2"
2	3"	2	4"
3	3-1/2"	3	4"
4	4"	4	5"
5	5"	5	6"
6	5"	6	6"

This illustration is for concept only and should not be used for any actual installation without engineering or technical advice from a licensed engineer. All necessary equipment may not be illustrated.

LIT0138

LEGEND

FULL PORT BALL VALVE	SYSTEM PUMP	SYSTEM RELIEF VALVE	TEE	ELBOW	UNION	EXPANSION TANK	CHECK VALVE	THERMOMETER	REDUCING TEE	REDUCING TEE

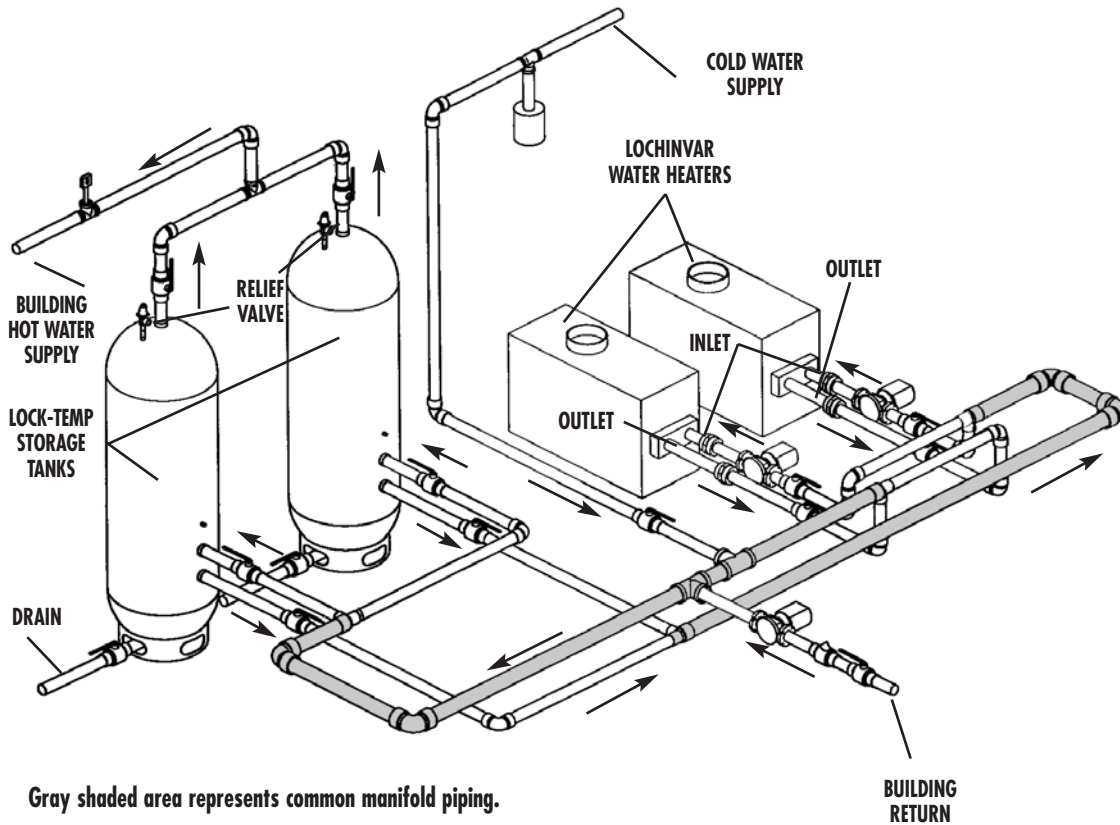

Gray shaded area represents common manifold piping.

COMMON WATER MANIFOLD SIZE FOR MULTIPLE WATER HEATER INSTALLATION

Pipe sizing chart provides minimum pipe size for common manifold piping to ensure adequate flow.

NUMBER OF UNITS	COMMON MANIFOLD SIZE (Min.)	NUMBER OF UNITS	COMMON MANIFOLD SIZE (Min.)
CW 495-745		CW 986-2066	
1	2"	1	2-1/2"
2	3"	2	4"
3	3-1/2"	3	4"
4	4"	4	5"
5	5"	5	6"
6	5"	6	6"

This illustration is for concept only and should not be used for any actual installation without engineering or technical advice from a licensed engineer. All necessary equipment may not be illustrated.

LIT0451

LEGEND

FULL PORT BALL VALVE	SYSTEM PUMP	SYSTEM RELIEF VALVE	TEE	ELBOW	UNION	EXPANSION TANK	CHECK VALVE	THERMOMETER	REDUCING TEE	REDUCING TEE

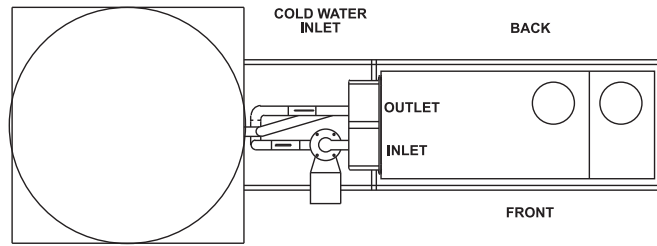

TOP VIEW

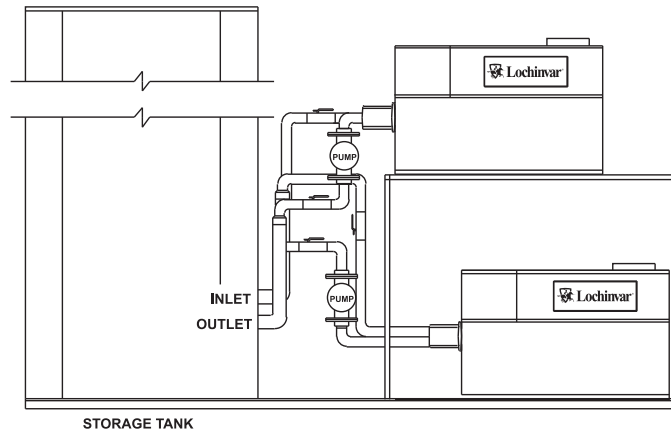

FRONT VIEW

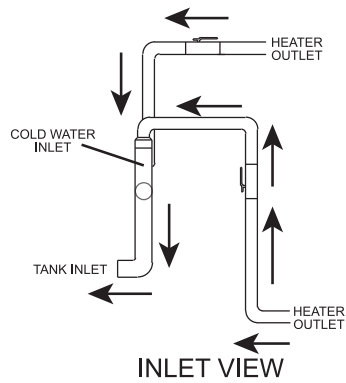

INLET VIEW

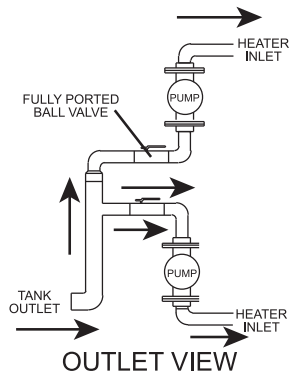

OUTLET VIEW

Heater Model	Heater Inlet/Outlet Size	Manifold Pipe Size
CW495-745	2"	3"
CW986-2066	2-1/2"	4"

LIT0396



Lochinvar Corporation • Lebanon, TN • 615-889-8900 / Fax: 615-547-1000
www.Lochinvar.com

Free Manuals Download Website

<http://myh66.com>

<http://usermanuals.us>

<http://www.somanuals.com>

<http://www.4manuals.cc>

<http://www.manual-lib.com>

<http://www.404manual.com>

<http://www.luxmanual.com>

<http://aubethermostatmanual.com>

Golf course search by state

<http://golfingnear.com>

Email search by domain

<http://emailbydomain.com>

Auto manuals search

<http://auto.somanuals.com>

TV manuals search

<http://tv.somanuals.com>