

LTV VALVE APPLICATION INSTRUCTIONS FOR LOW TEMPERATURE PROTECTION COPPER-FIN AND POWER-FIN MODELS CB 495 - 2066 / CH 401 - 2071 AND PB 501 - 2000

Kit components:

VAL30000 - 1 1/2" VALVE

Models: CB 45 - 500

- VAL20000 1 1/2" LTV Valve
- INS7238 Instruction Sheet

VAL3048 - 2" VALVE

Models: CB 495 - 745 and CH 401 - 751

- VAL2123 2" LTV Valve
- INS7238 Instruction Sheet

VAL3047 - 2 1/2" VALVE

Models: CB 986 - 2066, CH 991 - 2071, and PB 501 - 2000

- VAL2124 2 1/2" LTV Valve
- BLT2118 Bolt (12)
- BLT2119 Nut (12)
- BLT2026 Flat Washer (24)
- BLT2120 Star Washer (12)
- GKT2055 Gasket (3)
- TFL2092 Flange (3)
- INS7238 Instruction Sheet

CAUTION

Pump and motor unit are designed to be supported by the inline piping only. Do not support in any other manner. When placing pump between flanges, tighten flange bolts evenly and do not tighten excessively.

Figure 1_ 1 1/2" Valve

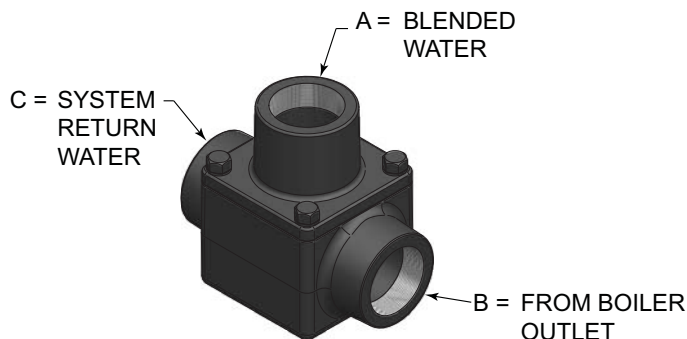

NOTE: A-B-C is noted on the valve to depict proper orientation.

Figure 2_ 2" Valve

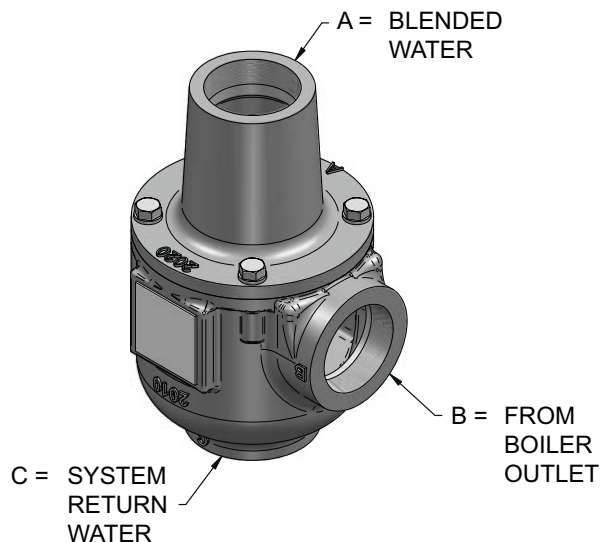

NOTE: A-B-C is noted on the valve to depict proper orientation.

Figure 3_ 2 1/2" Valve

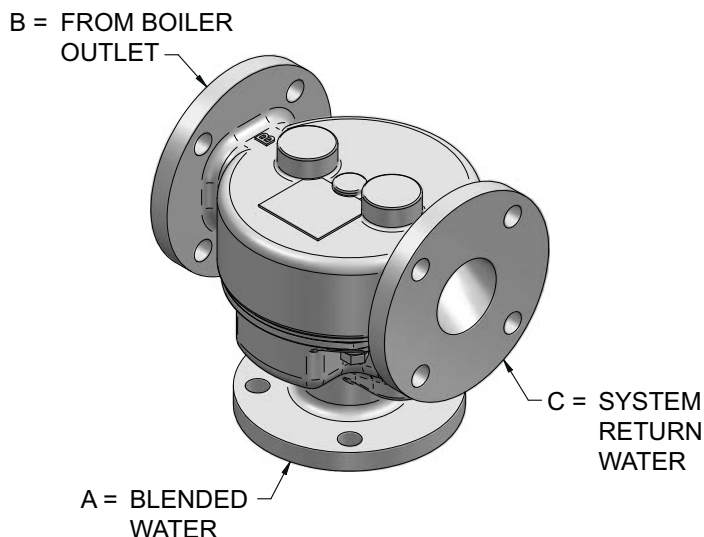

NOTE: A-B-C is noted on the valve to depict proper orientation.

Typical piping applications:

Figure 4_Primary/Secondary Piping of a Single Boiler - 1 1/2" Valve

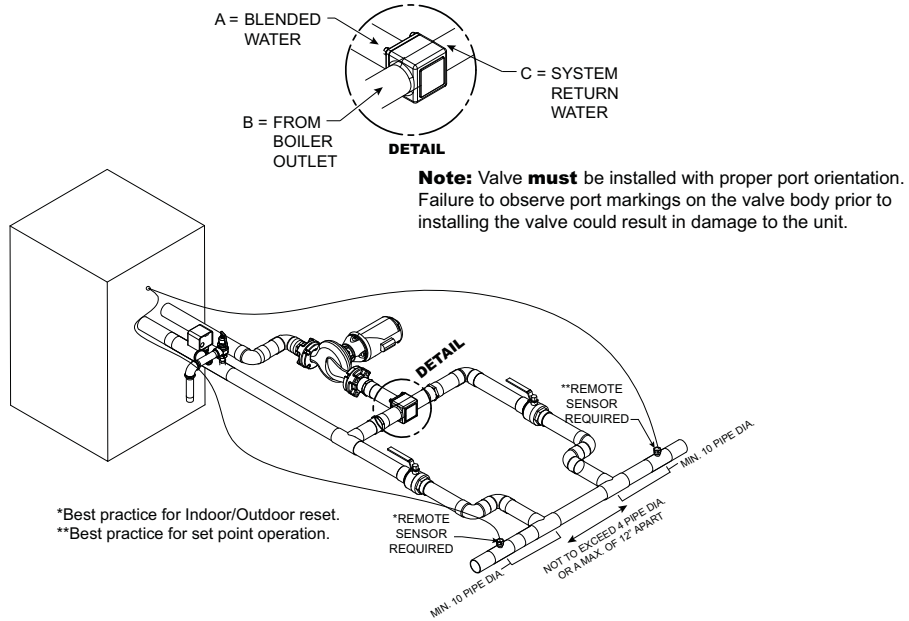

- NOTES:**
- 1) Unit(s) high limit must be set at max.
 - 2) Inlet and outlet connections to the boiler are shown for reference only. Actual connections may vary from those represented here. Consult the Installation and Service Manual for actual locations.
 - 3) Unit(s) pump should operate only during firing periods.

Figure 5_Primary /Secondary Piping of Multiple Boilers - 1 1/2" Valve for each boiler

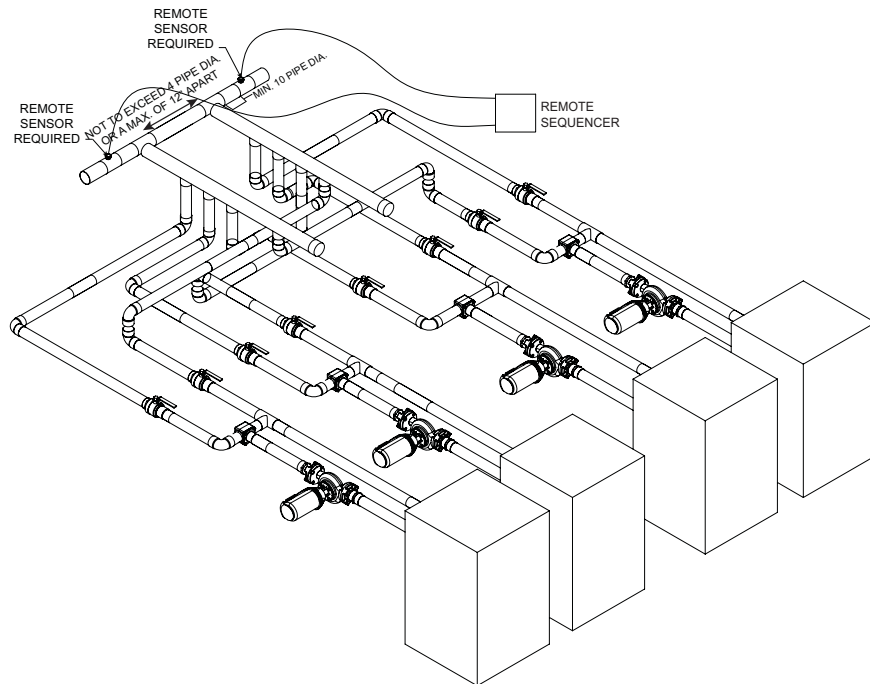

- NOTES:**
- 1) Unit(s) high limit must be set at max.
 - 2) Inlet and outlet connections to the boiler are shown for reference only. Actual connections may vary from those represented here. Consult the Installation and Service Manual for actual locations.
 - 3) Unit(s) pump should operate only during firing periods.

Typical piping applications (cont.):

Figure 6_Primary /Secondary Piping of a Single Boiler - 2" Valve

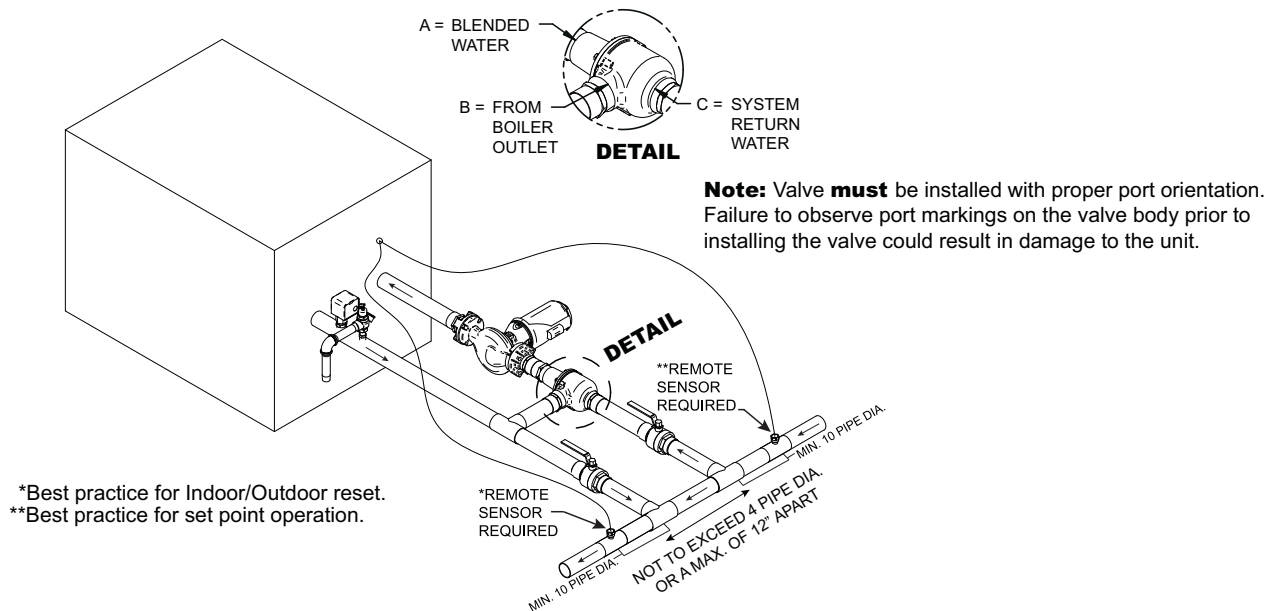

- NOTES:**
- 1) Unit(s) high limit must be set at max.
 - 2) Inlet and outlet connections to the boiler are shown for reference only. Actual connections may vary from those represented here. Consult the Installation and Service Manual for actual locations.
 - 3) Unit(s) pump should operate only during firing periods.

Figure 7_Primary/Secondary Piping of Multiple Boilers - 2" Valve for each boiler

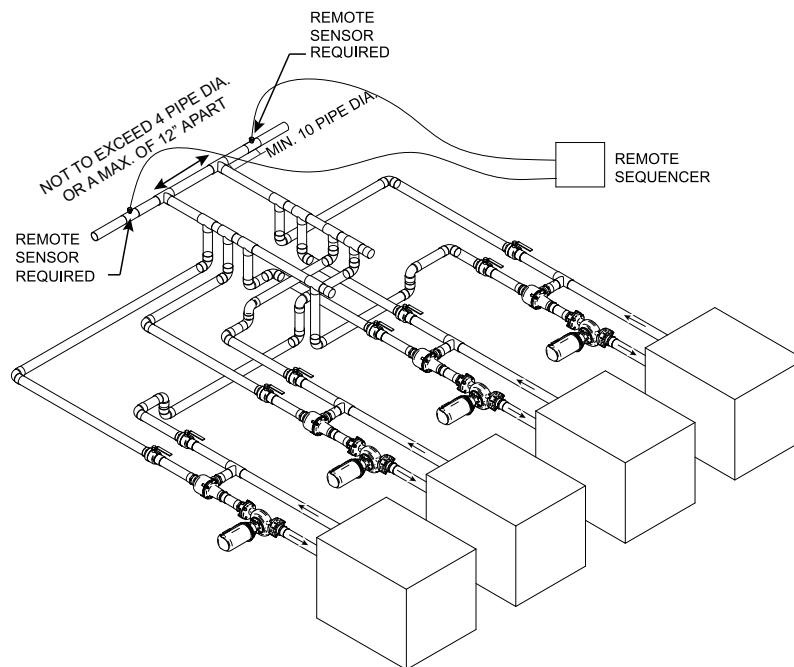

- NOTES:**
- 1) Unit(s) high limit must be set at max.
 - 2) Inlet and outlet connections to the boiler are shown for reference only. Actual connections may vary from those represented here. Consult the Installation and Service Manual for actual locations.
 - 3) Unit(s) pump should operate only during firing periods.

Typical piping applications (cont.):

Figure 8_Primary/Secondary Piping of a Single Boiler - 2 1/2" Valve

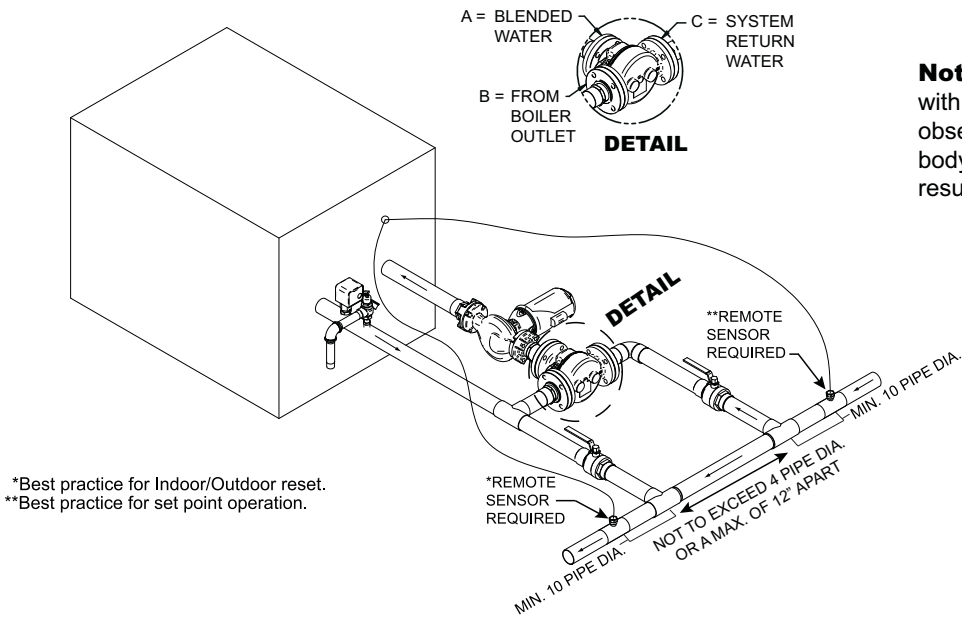

Note: Valve **must** be installed with proper port orientation. Failure to observe port markings on the valve body prior to installing the valve could result in damage to the unit.

- NOTES:**
- 1) Unit(s) high limit must be set at max.
 - 2) Inlet and outlet connections to the boiler are shown for reference only. Actual connections may vary from those represented here. Consult the Installation and Service Manual for actual locations.
 - 3) Unit(s) pump should operate only during firing periods.

Figure 9_Primary/Secondary Piping of Multiple Boilers - 2 1/2" Valve for each boiler

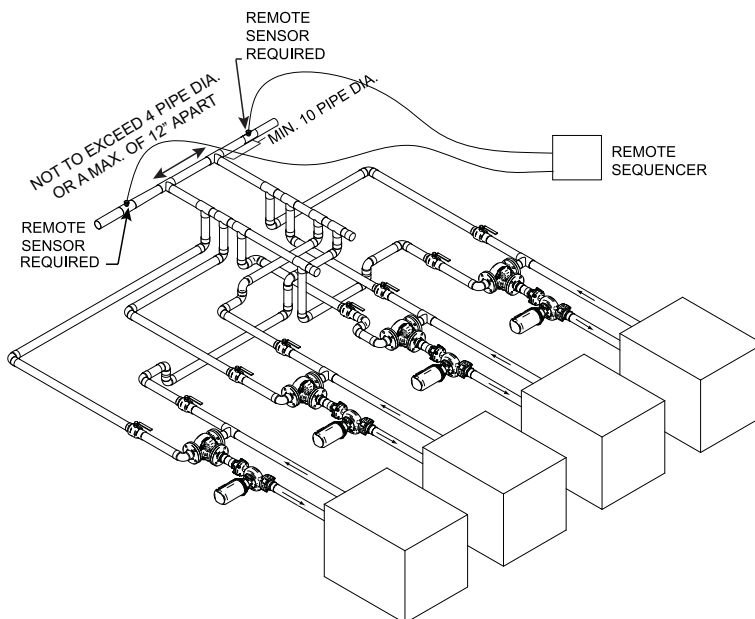

- NOTES:**
- 1) Unit(s) high limit must be set at max.
 - 2) Inlet and outlet connections to the boiler are shown for reference only. Actual connections may vary from those represented here. Consult the Installation and Service Manual for actual locations.
 - 3) Unit(s) pump should operate only during firing periods.

Figure 10_1 1/2" LTV Valve - 45,000 - 500,000 Btu/hr

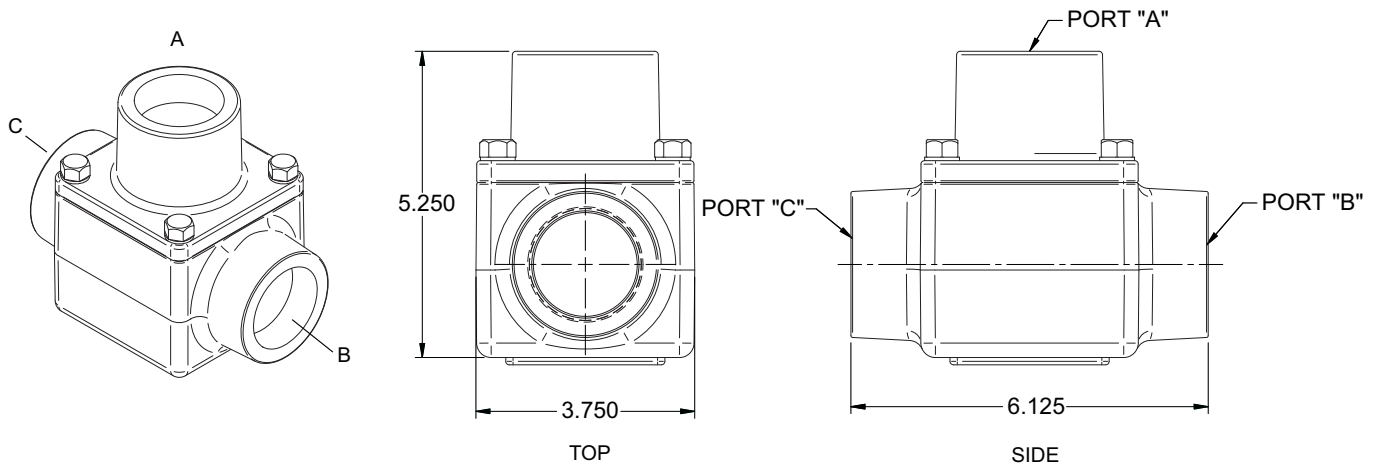

Figure 11_2" LTV Valve - Up to 750,000 Btu/hr

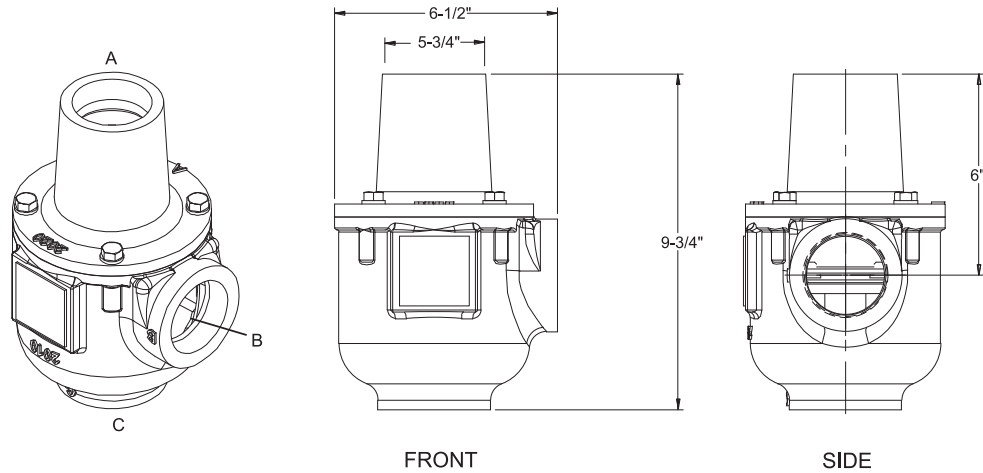

Figure 12_2 1/2" LTV Valve - 990,000 Btu/hr and up

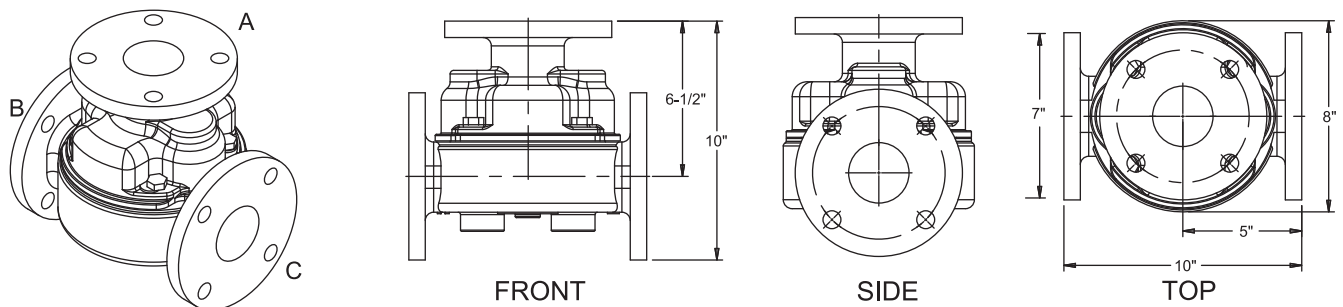

Figure 13_1 1/2" - Flow vs. Pressure Drop

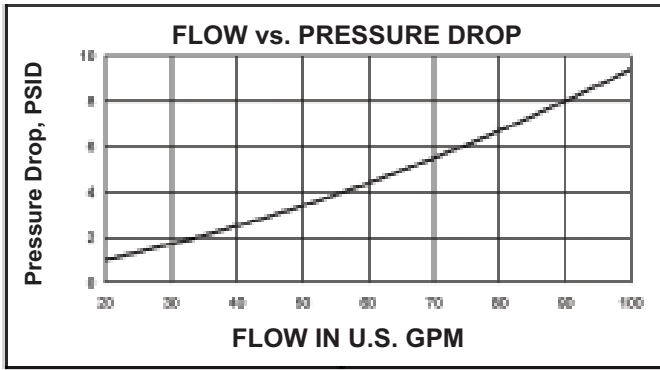

Figure 14_2" - Flow vs. Pressure Drop

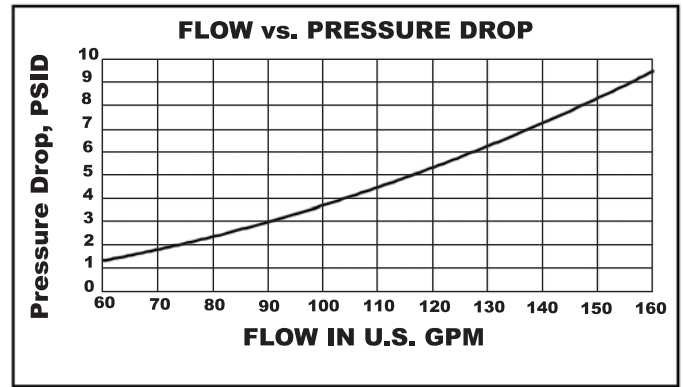
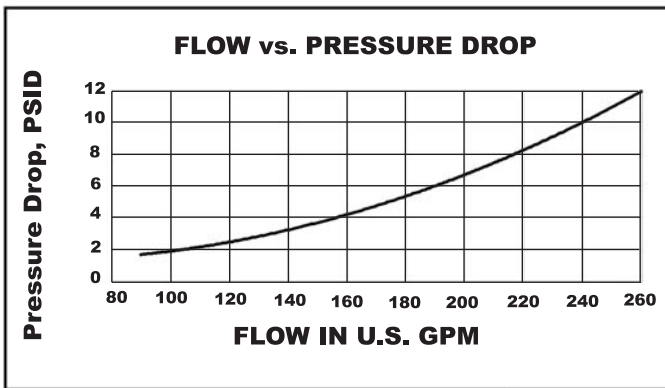

Figure 15_2 1/2" - Flow vs. Pressure Drop



Maintenance instructions

The LTV valve is maintenance free. It does not require regular cleaning or calibration. In most installations, the 1-1/2" and 2" valves are hard piped into place and do not afford access. The 2-1/2" valve has flanged connects which allows removal.

If the valve becomes unable to maintain a consistent inlet water temperature of 125°F during steady state firing conditions, replace the valve or the wax element inside the valve.

⚠ WARNING

The recommended maximum high temperature to the valve should be 175°F; the absolute maximum is 195°F.

Notes

Revision Notes: *Revision A (INS7238 Rev A) reflects the addition of the 1 1/2" valve.*

Revision B (INS7238 Rev B) reflects the addition of the maintenance instructions.

Revision C (ECO C02335) reflects the revision of FIG.'s. 1, 2, 3, 4, 6 & 8.

10/08 - Printed in U.S.A.

Free Manuals Download Website

<http://myh66.com>

<http://usermanuals.us>

<http://www.somanuals.com>

<http://www.4manuals.cc>

<http://www.manual-lib.com>

<http://www.404manual.com>

<http://www.luxmanual.com>

<http://aubethermostatmanual.com>

Golf course search by state

<http://golfingnear.com>

Email search by domain

<http://emailbydomain.com>

Auto manuals search

<http://auto.somanuals.com>

TV manuals search

<http://tv.somanuals.com>