



Finish Pro Series FP-148-C, FP-160-C, and FP-172-C



Operator's Manual

Locke Turf Inc.
307 Highway 52E, Opp, Alabama 36467, (334) 493-1300

CONGRATULATIONS

You have invested in the best implement of its type on the market today.

The care you give you Locke Turf implement will greatly determine your satisfaction with its performance and its service life. We urge a careful study of this manual to provide you with a thorough understanding of you new implement before operating, as well as suggestions for operation and maintenance.

If your manual should become lost or destroyed, Locke Turf will be glad to provide you with a new copy. Order from Locke Turf, 307 Highway 52E, Opp, Alabama 36467.

As and Authorized Locke Turf dealer, we stock genuine Locke Turf parts which are manufactured with the same precision and skill as our original equipment. Our trained service personnel are well informed on methods required to service Locke Turf equipment, and are ready and able to help you.

Should you require additional information or assistance, please contact us.

YOUR AUTHORIZED
LOCKE TURF DEALER

BECAUSE LOCKE TURF MAINTAINS AN ONGOING PROGRAM OF PRODUCT IMPROVEMENT, WE RESERVE THE RIGHT TO MAKE IMPROVEMENTS IN DESIGN OR CHANGES IN SPECIFICATIONS WITHOUT INCURRING ANY OBLIGATION TO INSTALL THEM ON UNITS PREVIOUSLY SOLD.

BECAUSE OF THE POSSIBILITY THAT SOME PHOTOGRAPHS IN THIS MANUAL WERE TAKEN OF PROTOTYPE MODELS, PRODUCTION MODELS MAY VARY IN SOME DETAIL. IN ADDITION, SOME PHOTOGRAPHS MAY SHOW SHIELDS REMOVED FOR PURPOSES OF CLARITY. **NEVER OPERATE** THIS IMPLEMENT WITHOUT ALL SHIELDS IN PLACE.

FP-100

TABLE OF CONTENTS

SECTION		SECTION	
Introduction	2	Operation	10
Dealer Preparation Check List	3	Transporting	10
Safety Alert Symbols	4	IV. MAINTENANCE	
Safety Precautions	5	Maintenance Check List	12
Federal Laws and Regulations	6	Lubrication	12
I. INTRODUCTION & DESCRIPTION	7	Spindle Belt Adjustment	13
Introduction	7	Spindle Belt Replacement	13
Description	7	Blade Replacement	14
II. PREPARATION FOR USE	8	Blade Spindle Service	15
Attaching To Tractor	8	Troubleshooting	15
III. OPERATING INSTRUCTIONS	9	Safety Decals	16
General Safety	9	Torque Specifications	18
Cutting Height Adjustment	9	Spindle Service Instructions	19

RETAIL CUSTOMER'S RESPONSIBILITY UNDER THE LOCKE TURF WARRANTY

It is the Retail Customer and/or Operator's responsibility to read the Operator's Manual, to operate, lubricate, maintain and store the product in accordance with all instructions and safety procedures. Failure of the operator to read the Operator's Manual is a misuse of this equipment.

It is the Retail Customer and/or Operator's responsibility to inspect the product and to have any part(s) repaired or replaced when continued operation would cause damage or excessive wear to other parts or cause a safety hazard.

It is the Retail Customer's responsibility to deliver the product to the authorized Locke Turf Dealer, from whom he purchased it, for service or replacement of defective parts that are covered by warranty. Repairs to be submitted for warranty consideration must be made with-in forty-five (45) days of failure.

It is the Retail Customer's responsibility for any cost incurred by the Dealer for traveling to or hauling of the product for the purpose of performing a warranty obligation or inspection.

INTRODUCTION

More than merely devices created for mowing grass, the excellence of design, construction and operation of Locke power mowers is unparalleled. Introduced in 1928, tested and proven, Locke power mowers may be considered, in terms of today's technology, the ultimate response to the need for the highest degree of quality lawn care. These magnificent green machines are legendary and known throughout the world for generation-spanning durability and unequalled performance in the precision cutting of grass.

Locke power mowers are heavy-duty, precision instruments. No capricious model year or cosmetic style changes are instituted, although improvements are continually incorporated into all models. The most recent evidence this is in the introduction of the new "Commercial Series". Design and manufacturing innovations make this the mower for the next century. Whatever model of Locke power mower you have purchased you have our assurance that, with proper care, you are the owner of a machine which will provide many years of dependable service.

To extract the fullest possible value from the performance of your Locke power mower we urge you to read this manual very carefully. Should you find any of the instructions unclear, please contact your Locke dealer or call the Locke Factory Service Department.

Phone: 334-493-1300

Fax: 334-493-1400

Locke Mowers: The Finest Cut....For The Finest Lawns

DEALER PREPARATION CHECK LIST

Single Deck Finishing Mower FP-100

BEFORE DELIVERING MACHINE- The following check list should be completed. Use the Operator's Manual as a guide.

- 1. Assembly completed.
- 2. Gearboxes filled with oil.
- 3. All fittings lubricated.
- 4. All shields in place and in good condition.
- 5. All fasteners torqued to specifications given in Torque Chart.
- 6. All decals in place and readable. (See decal page.)
- 7. Overall condition good (i.e. paint, welds)
- 8. Operators manual has been delivered to owner and he has been instructed on the safe and proper use of the mower.

Dealer's Signature _____

Purchaser's Signature _____

THIS CHECKLIST IS TO REMAIN IN OWNER'S MANUAL
It is the responsibility of the dealer to complete the procedures listed
above before delivery of this implement to the customer.

Safety Alert Symbol

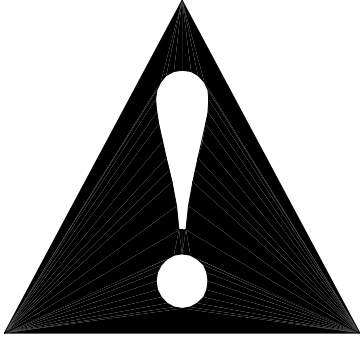

This Safety Alert Symbol means: “**ATTENTION! BECOME ALERT! YOUR SAFETY IS INVOLVED!**”

This symbol is used to call attention to safety precautions that should be followed by the operator to avoid accidents. When you see this symbol, carefully read the message that follows and heed its advice. Failure to comply with safety precautions could result in death or serious bodily injury.

Safety Signs Signal Words

The signal words **DANGER, WARNING AND CAUTION** are used on the equipment safety signs. These words are intended to alert the viewer to the existence and the degree of hazard seriousness.



This signal word indicates a potentially hazardous situation, which, if not avoided, will result in death or serious injury.



This signal word indicates a potentially hazardous situation, which, if not avoided, will result in death or serious injury. It may also be used to alert against unsafe practices.



This signal word indicates a potentially hazardous situation exist, which, if not avoided, may result in minor or moderate injury. It may also be used to alert against unsafe practices.

IMPORTANT SAFETY PRECAUTIONS

This symbol is used to call attention to safety precautions that should be followed by the operator to avoid accidents. When you see this symbol, carefully read the message that follows and heed its advice. Failure to comply with safety precautions could result in death or serious bodily injury.

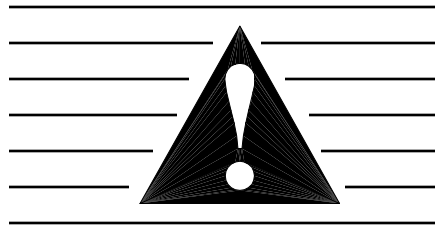

In addition to the design and configuration of equipment, hazard control and accident prevention are dependent upon the awareness, concern, prudence and proper training of personnel in the operation, transport, maintenance and storage of equipment. Lack of attention to safety can result in accident, personal injury, reduction of efficiency and worst of all – loss of life. Watch for safety hazards and correct deficiencies promptly. Use the following safety precautions as a general guide to safe operations when using this machine. Additional safety precautions are used throughout this manual for specific operation and maintenance procedures. Read this manual and review the safety precautions often until you know the limitations.

1. Read the Operator's Manual. Failure to read the Operator's Manual is considered a misuse of this equipment.
2. Become familiar with the entire machine's controls and all the caution, warning and danger decals affixed to the machine before attempting to start or operate.
3. Before starting or operating the machine, make a walking inspection and check for obvious defects such as loose mounting bolts and damaged components. Correct any deficiency before starting.
4. Do not allow children to operate the cutter. Do not allow adults to operate it without proper instruction.
5. Do not carry passengers.
6. Keep the area of operation clear of all persons, particularly small children and pets. The operator should cease mowing whenever anyone comes within the operating area.
7. Clear the work area of objects, which might be picked up and thrown.
8. Use a piece of cardboard or wood rather than hands to search for hydraulic leaks. Escaping hydraulic oil under pressure can penetrate skin. If fluid is injected into the skin, it must be surgically removed within a few hours by a doctor familiar with this form of injury or gangrene may result.
9. Do not operate without all guards and shields in place and in good condition.
10. Lower implement to ground, stop tractor engine, apply parking brake and allow blades to completely stop before leaving the tractor.
11. Keep hands and feet away from blades.
12. This cutter is not to be operated along highways or in any area where people may be present unless all sides of the unit are enclosed by permanent bans, safety chains or other factory approved safety shields that are in good repair.
13. Wear personal protective equipment such as, but not limited to, protection for eyes, ears, feet, hands and head when operating or repairing the equipment. Do not wear loose clothing or jewelry that may catch on equipment moving parts.
14. When performing adjustments or maintenance on the cutter, first lower it to the ground or block it securely at a workable height.
15. Never stand between tractor and cutter while tractor is being backed to the cutter hitch.
16. Reduce speed when transporting cutter to avoid bouncing and momentary loss of steering.
17. Use tractor flashing warning lights, day or night, when transporting cutter on road or high ways unless prohibited by law.
18. It is recommended that tractor be equipped with Rollover Protective System (ROPS) and seat belt be used in all mowing operations.

IMPORTANT FEDERAL LAWS AND REGULATIONS* CONCERNING EMPLOYERS, EMPLOYEES AND OPERATIONS.

*(This section is intended to explain in broad terms the concept and effect of the following federal laws and regulations. It is not intended as a legal interpretation of the laws and should not be considered as such.)

U.S. Public Law 91-596 (The Williams-Steiger Occupational and Health Act of 1970) OSHA

This Act Seeks:

"...to assure so far as possible every working man and woman in the nation safe and healthful working conditions and to preserve our human resources..."

DUTIES

Sec. 5 (a) Each employer-

- (1) shall furnish to each of his employees employment and a place of employment which are free from recognized hazard that are causing or are likely to cause death or serious physical harm to his employees;
- (2) shall comply with occupational safety and health standards promulgated under this Act.
 - a. Each employee shall comply with occupational safety and health standards and all rules, regulations and orders issued pursuant to this Act which are applicable to his own actions and conduct.

OSHA Regulations

Current OSHA regulations state in part: "At the time of initial assignment and at least annually thereafter, the employer shall instruct every employee in the safe operation and servicing of all equipment with which the employee is or will be involved." These will include (but are not limited to) instructions to:

Keep all guards in place when the machine is in operations:

Permit no riders on equipment;

Stop engine, disconnect the power source and wait for all machine movement to stop before servicing, adjusting, cleaning or unclogging the equipment, except where the machine must be running to be properly serviced or maintained, in which case the employer shall instruct employees as to all steps and procedures which are necessary to safely service or maintain the equipment.

Make sure everyone is clear of machinery before starting the engine, engaging power or operating the machine.

EMPLOYEE TRACTOR OPERATING INSTRUCTIONS:

1. Securely fasten your seat belt if the tractor has a ROPS
2. Where possible avoid operating the tractor near Ditches, embankments and holes.
3. Reduce speed when turning, crossing slopes and on rough, slick or muddy surfaces
4. Stay off slopes too steep for safe operation
5. Watch where you are going especially at row ends, on roads and around trees.
6. Do not permit others to ride.
7. Operate the tractor smoothly – jerky turns starts or stops
8. Hitch only to the drawbar and hitch points recommended by tractor manufacturers
9. When tractor is stopped, set brake securely and use park lock if available

Child Labor Under 16 Years Old

Some regulations specify that no one under the age of 16 (sixteen) may operate power machinery. It is your responsibility to know what these regulations are in you own area or situation. (Refer to U.S. Dept, of Labor, Employment Standard Administration, Wage & Home Division, Child Labor Bulletin #102.)

SECTION I INTRODUCTION AND DESCRIPTION

1-1 INTRODUCTION

We are pleased to have you as a Locke Turf customer. Your FP-100 has been carefully designed to give maximum service with minimum down time. This manual is provided to give you the necessary operating and maintenance instructions for keeping your mower in top operating condition. Please read this manual thoroughly. Understand what each control is for and how to use it. Observe all safety precautions decaled on the machine and noted throughout the manual for safe operation of the implement. If any assistance or additional information is needed, contact your authorized Locke Turf distributor.

NOTE

All references made to right, left, front, rear, top or bottom is as viewed facing the direction of travel with implement properly attached to tractor.

1-2 DESCRIPTION

The MP-172, (figure 1-1), is designed for turf maintenance applications where a high quality of cut on turf grasses is required.

Three sets of rotating blades (per deck) continue to cut the grass clippings several times before allowing the tiny pieces to fall to the ground. This eliminates a build up of grass residue on top of the turf. The caster wheel arrangement along with the flexible, floating deck attachment, the standard front mounted rollers and the under deck roller all work together to give an even cut and minimize scalping.

NOTE: All wheels on the mower deck are rigidly mounted and are not designed to caste.

Power from the tractor is transmitted through a telescoping driveline to a gearbox arrangement. Power is passed to the spindle housings by a B-section, Kevlar reinforced belt. Drive train protection is provided by belt slippage.

Technical Specifications

Specification	FP
Cutting Width	48", 60", 72"
Transport Width	48", 60", 72"
Cutting Height	1/2" to 4-1/4"
Blade Tip Speed (FPM)	15,000 FPM
Required Tractor PTO HP	15HP min.
Belts	Cat. IV 80° CV (main)
Driveline Size	540 RPM - 1-3/8"-6 Spline

Figure 1-1 FP-172



SECTION II PREPARATION FOR USE

Before operation, service all locations outlined in Section 4-2 "Lubrication" and remove transport lock pins from mower decks as shown in Figure 3-4. Unpin inside wing tires and reposition into a trailing position and re-pin in place. Break in the mower in a static condition at half throttle for 30 minutes. Inspect all belts for proper tension; check gearboxes for proper oil levels and check to make sure blade spindles are not overheating.

2-1 ATTACHING TO TRACTOR IMPORTANT (540 RPM ONLY)

The minimum required PTO horsepower is 15 HP for the FP-100.



WARNING

NEVER STAND BETWEEN TRACTOR AND MOWER WHILE TRACTOR IS BEING BACKED TO HITCH.

A. Adjust tractor drawbar length to dimension shown in Figure 2-1. Incorrect drawbar length will change angle of driveline causing possible damage to constant velocity joint. See tractor operator's manual for drawbar adjustment procedure.

Figure 2-1 Tractor Drawbar Adjustment

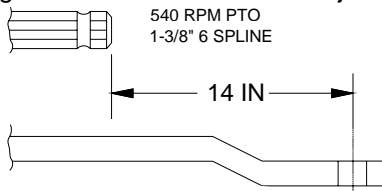

NOTE:
Offset drawbar must be turned down as shown.

If after turning the offset draw bar downward, there is less than 7" ground clearance, it should be replaced with a straight draw bar or the unit cannot be properly leveled.

IMPORTANT
PTO ADAPTERS SHOULD NOT BE USED WITH ANY LOCKE TURF EQUIPMENT. FAILURE TO FOLLOW THESE INSTRUCTIONS WILL CAUSE DRIVELINE FAILURE AND POSSIBLE TRACTOR DAMAGE.

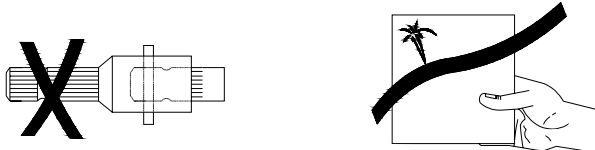

B. Attach jack stand to frame of cutter. Extend jack stand to support weight of frame.

C. Connect clevis hitch to tractor drawbar using a 1 inch (25 mm) diameter approved pin with lynch pin retainer or equivalent.

D. Adjust tongue and clevis angle as necessary to keep mower frame level with ground when attached to drawbar. (Figure 2-2)

Figure 2-2 Tongue/Clevis Adjustment

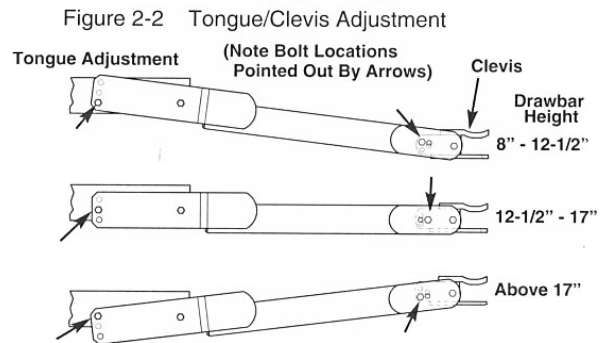

It is important that the FP is operated in a level position. Leveling can be accomplished by adjusting the tractor draw bar height, also by leveling the mower frame by use of the adjustable jack stand.

If after properly leveling the mower frame the draw bar height is less than 8", a standard pull pin may be too long. To prevent turf damage in uneven terrain, the standard pin should be replaced with a 1" x 5" Grade 5 bolt with locknut securely tightened.

E. Connect hydraulic hose to tractor remote quick couplers. (See tractor dealer if furnished couplers are not correct for your particular tractor.) Make sure hydraulic line is not twisted or kinked.



WARNING

USE A PIECE OF CARDBOARD OR WOOD RATHER THAN HANDS AND WEAR EYE PROTECTION WHEN SEARCHING FOR HYDRAULIC LEAKS. ESCAPING HYDRAULIC OIL UNDER PRESSURE CAN PENETRATE SKIN. IF OIL IS REMOVED WITHIN A FEW HOURS OR GANGRENE MAY RESULT.

F. Route control chain to convenient location and fasten to tractor. Be sure excess slack is removed from the chain to avoid entanglement with tractor tires or other moving parts. Make sure latch locking pins are in the stored positions so that latches can be released by pulling the chain. (Refer to Figures 3-3 and 3-4)

G. Attach driveline to tractor. Pull on each driveline section to be sure that yoke locks into place.
H. Securely attach safety chain to tractor.

Figure 2-3
Control Chain

SECTION III OPERATING INSTRUCTIONS

3-1 GENERAL SAFETY

Only qualified people familiar with this operator's manual and tractor operator's manual should operate this machine. Operator should wear hardhat, safety glasses and safety shoes. The operator should read, understand and practice all safety messages shown on the caution, warning and danger decals affixed to the mower to avoid serious injury or death. It is recommended that tractors be equipped with Rollover Protective System (ROPS) and a seat belt must be used. Before beginning operation, clear work area of any objects that may be picked up and thrown, check for ditches, stumps, holes or other obstacles that could upset tractor or damage mower. Always lower mower to ground and allow blades to come to a complete stop, having set parking brake and turn off the tractor's engine before leaving the tractor operator's seat.

NOTE: Before initial operation the FP-100 Series should be connected to the tractor for a 30-minute "run in" cycle. During the "run in" phase, the tractor should be operated at only half throttle. The "run in" cycle is complete, ALL belts should be inspected for proper tension and if adjustments are necessary, refer to Maintenance Section.

3-2 CUTTING HEIGHT ADJUSTMENT

The mower should be operated at the highest position that will give desired cutting results. This will help prevent blades from striking the ground, reducing blade wear and unnecessary strain on the machine. Cutting too much material may reduce mulching action and leave visible clippings on the lawn surface. The more frequently the grass is

- A. Raise the mower off ground enough to remove caster.



WARNING

THE MOWER CAN FALL FROM HYDRAULIC SYSTEM FAILURE. TO AVOID SERIOUS INJURY OR DEATH, SECURELY SUPPORT MOWER BEFORE WORKING UNDERNEATH.

- B. Remove pin securing caster stem to caster arm. Remove caster stem from caster arm.
C. Place amount of spacers on caster stem to give desired cutting height. With no spacers on the bottom, a 3/4" cutting height is given. (Figure 3-1)
D. Reinstall caster stem into caster arm. Place remaining spacers on caster stem above caster arm and install pin to retain.
E. Repeat operation for all caster wheels. Make certain all wheels are adjusted to the same height.

Figure 3-1

Caster Wheel
Spacers

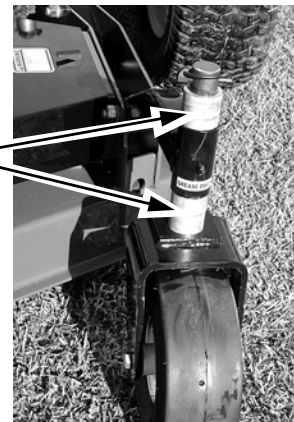

TIPS ON MOWING WITH A FINISHING MOWER

The Locke Turf Finish Pro is a turf maintenance mower that uses sharp blades to maintain a healthy and beautiful appearance of your turf. To obtain the maximum effectiveness from your Finish Pro the tips listed below should be followed:

Mow often – In general, mulching operations require more frequent mowing than would conventional mowing procedures.

Watch your speed – Normal conditions will allow a speed of up to approximately 5 mph, but thick, heavy, damp conditions will require reduced ground speed.

Mow at 540 RPM to keep tip speed at its maximum.

Mow with a clean mower – Avoid grassy build-up under the deck.

Mow with sharp blades – A sharp blade cuts cleaner.

Wet grass will decrease distribution effectiveness and increase horsepower requirements.

Mow at higher cutting heights – Remove no more than 2" – 2-1/2" of grass length with each mowing. (Experts recommend not cutting off more than 1/3 of the grass blade length at any given time.)

Mow twice, at different height settings, (high, then low), if grass is extra tall.

Remember that horsepower requirements will vary with the mowing conditions such as type and height of turf grass, moisture content, whether the terrain is flat or hilly, etc.

The ideal cutting height may be different from other types of mowing equipment you have used. Initially you should adjust your FP at least 1/2" higher than other types of equipment. Use a trial and error method to determine if the FP should be adjusted lower. Generally it is best to begin high and work your way lower.

SECTION IV MAINTENANCE

4-1 MAINTENANCE CHECK LIST

Perform scheduled maintenance as outlined below. Lower implement to ground, turn off tractor and set parking brake before doing maintenance inspections or work. All bolts should be torqued as indicated in torque chart unless otherwise indicated.



WARNING

THE MOWER CAN FALL FROM HYDRAULIC SYSTEM FAILURE. TO AVOID SERIOUS INJURY OR DEATH, SECURELY SUPPORT MOWER BEFORE WORKING UNDERNEATH.

BEFORE EACH USE

1. Check tractor tire air pressure. Refer to tractor operator's manual. **Mower transport tire pressure should be 22 psi; deck tire pressure should be 50 psi.**
2. Check blades and spindles to be sure that no foreign objects such as wire or steel strapping bands are wrapped around them.
3. Check blade bolts for tightness. **Tighten bottom blade bolts to 76 ft./lbs, top mulching blade bolts to 45 ft./lbs.**
4. Inspect blades for wear. Replace if necessary per paragraph 4-5. Use only genuine Locke Turf replacement parts. If it is necessary to sharpen the blades, remove the blades from the spindles before sharpening. **DO NOT sharpen blades while still attached to mower.**
5. Make certain all shields are in place and in good condition. Repair or replace any missing or damaged shields.
6. Inspect wheel(s) for wear, damage or foreign objects. Repair or replace any missing or damaged shields.
7. Perform BEFORE EACH USE lubrication per paragraph 4-2.
8. During operation, listen for abnormal sounds, which might indicate loose parts, damaged bearings, or other damage. Correct any deficiency before continuing operation.

AFTER EACH USE

1. Clean all debris from machine especially underside of deck, underneath belt shield and off safety decals. Replace any missing or illegible decals.
2. Inspect cutter for worn or damaged components. Repair or replace before next use. Any replacement components installed during repair shall include the components' current safety decals specified by the manufacturer to be affixed to the component.
3. Store cutter in a dry place.

40 HOURS

Check belt for proper tension. Refer to paragraph 4-3.

4-2 LUBRICATIONS

NOTE

The multi-purpose grease referenced in this section is a NLGI Grade 2 type grease. Figure 4-2 shows the necessary position for servicing wing drivelines.

BEFORE EACH USE

1. Drive line Universal Joints – Apply multi-purpose grease with grease gun.
2. Drive line Guard – Apply 2-3 shots of multi-purpose grease with grease gun to plastic fitting.
3. Wheels – Apply multi-purpose grease with grease gun.
4. Caster Pivot – Apply multi-purpose grease with grease gun.
5. **Constant Velocity (CV) Joint – Position CV joint as straight as possible to be sure grease will penetrate to ball joint. Lubricate the central body with a minimum of 30 shots of grease every 8 hours. Lubricate telescoping members with 10 shots every 8 hours and every 40 hours pull the two sections apart, apply thin coat of multi-purpose grease to outside of inner (male) section and reassemble.**

20 HOURS

6. Deck Drivelines – Disconnect PTO driveline, pull the two sections apart, apply thin coat of multi-purpose grease to outside of inner (male) section. Reassemble sections and install. Pull each section to be sure driveline and shields are securely connected. Make certain PTO shielding is in good condition.

40 HOURS

7. Gear boxes (5) – Add EW80W-90 gear oil, if necessary, to bring oil level to check plug or dip stick mark.

END OF SEASON

8. Transport Wheel Bearings – Pack transport wheel bearings with grease at end of each mowing season.



4-3 SPINDLE BELT ADJUSTMENT

Belt tensions should be checked every 40 hours to get maximum life from drive belts and best performance from the cutter. Belt tension is adjusted by increasing or decreasing the length of the spring on the moveable idlers.

For proper belt tension on the mower, the spring lengths should be set at 2-7/8". To adjust the spring length, loosen or tighten the 1/2" hex nuts on the spring adjustment rod until the correct spring length is reached.

4-4 SPINDLE BELT REPLACEMENT

Use only genuine Locke Turf replacements parts. It is not necessary to replace both belts if only one is worn.

- Flip up black latches and remove right and left side shields. To remove the outside shields on the wing cutter decks, the wings must be in the folded position.
- Relieve spring tension by loosening the two 1/2" hex nuts on each spring adjustment rod. (Figure 4-2)
- Remove old belts.
- Install new belts as shown below. (Also refer to the decal on underside of belt shield)

1. Belts must be installed at the same time. One belt cannot be installed and tightened down before the other.

4-5 BLADE REPLACEMENT



WEAR HEAVY WORK GLOVES TO PROTECT HANDS FROM SHARP EDGES. WHEN TURNING BLADES, BE AWARE OF OPPOSITE BLADE APPROACHING.

A complete spare set of blades comes with the cutter. The lower blades are pinned on the frame and the upper blades are stored in the tool box. (Figure 4-4) Always replace all (4) blades on an assembly to retain balance. In addition to replacing blades when they become worn and dull, they should also be replaced if the uplift angle on the trailing side of the blade becomes worn off. As the angle wears down, the mulching action deteriorates.

- Raise the cutter using the tractor hydraulic system and use transport locks before changing blades.
- Turn off tractor, set parking brake and remove key.

- Place both belts into their respective grooves on the driving sheave.
- Work the lower belt over the other sheaves. After the lower belt is in place, complete the installation of the upper belt. (Figure 4-3)
- Connect the upper adjustment rod and the upper idler assembly.
- Tighten the compression springs on the upper and lower drives to 2-7/8" long. Tighten the jam nuts on the adjustment rods.**
- Replace all shields before operating machine.

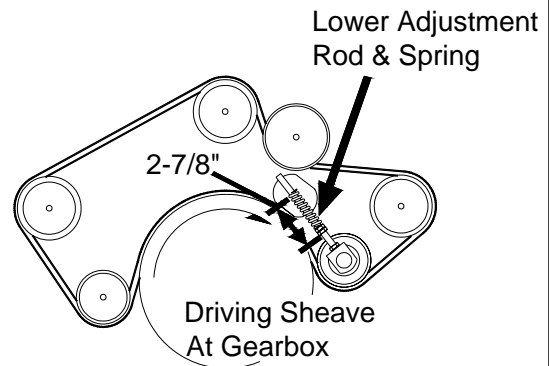

- Remove bolt and Belleville washer securing bottom blade to spindle. Remove blade. Shaft washer will come off with the blade.
- Install the blade washer over the spindle shaft. Install the bottom blade and **torque the 1/2" – 20 UNF Gr. 8 bolt to 76 ft./lbs.** Note: The concave side of the Belleville washer must be toward the blades. Do not substitute with a flatwasher.

Figure 4-4 Spare Blades and Tool Box

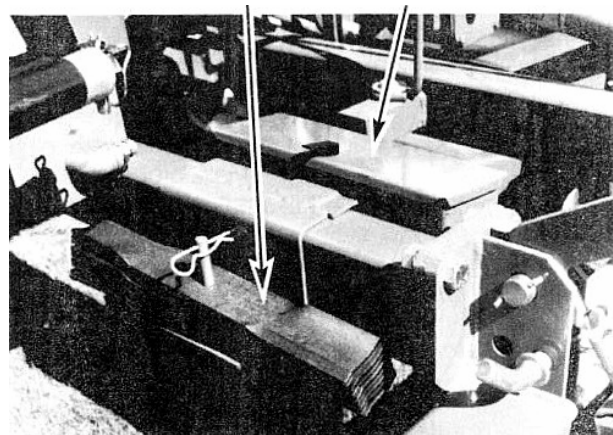

4-6 BLADE SPINDLE SERVICE

If shaft bearings or other parts require replacement, it is recommended that a Locke Turf dealer or other qualified person service the blade spindle. If blade spindles must be disassembled, a special wrench kit **must be used** to prevent damage to the assembly. This Wrench Kit (Part Number 50026073), including a sheave wrench, carrier wrench and complete instructions, is available from Locke Turf. (Figure 4-6) Refer to "Blade Spindle Service" at the rear of this manual.

Figure 4-6

Sheave Wrench

Carrier Wrench

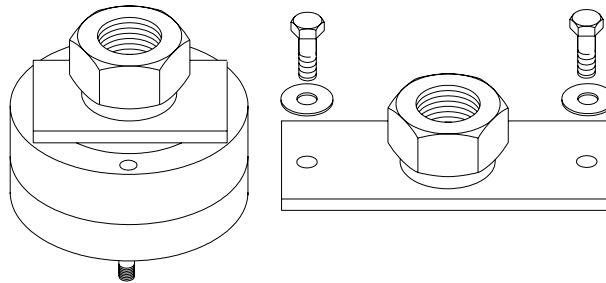

4-7 TROUBLESHOOTING

Troubleshooting procedures are listed in Table 4-1 below. If the problem cannot be solved or replacement parts are necessary, contact your authorized Locke Turf dealer. Please have ready your machine name, model number, serial number, purchase date and exact cause or description of the problem.

Table 4-1 Troubleshooting

PROBLEM	PROBABLE CAUSE	REMEDY
Uneven Cut	Cutter not level side to side or front to rear.	See SECTION III
	Belt slipping.	Adjust belt per paragraph 4-3
	Worn or bent blade(s).	Replace blade(s).
Streaking or Windrowing	Possible build-up of material under cutter.	Clean Cutter
	Cutter not level.	See SECTION III
	Worn blades.	Replace blades.
	Belt slipping.	Adjust belt per paragraph 4-3.
Noisy Cutter	Loose components.	Check all bolts for tightness.
	Low oil in gearbox.	Check oil per paragraph 4-2.
Rapid Blade Wear (cutting edge)	Blade contacting ground.	Adjust cutting height to eliminate ground contact.
Rapid Blade Wear	Cutter not being Operated at rated PTO speed.	Set tractor throttle for proper PTO speed. Use lower gear
	Cutter Vibrating	Cutter not being operated at rated PTO speed.
Cutter Vibrating	Blade(s) bent.	Replace blades.
	Foreign object wrapped around spindle or blade.	Remove object.

SAFETY DECALS

To promote safe operation, Locke Turf supplies safety decals on all products manufactured. Damage can occur to safety decals either through shipment, use or reconditioning, so Locke Turf will, upon request, provide safety decals for any of our products in the field at no charge. Contact your authorized Locke Turf dealer for more information.

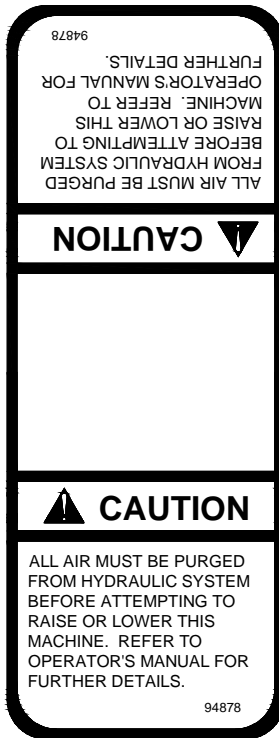

94878



83343



82619



50012615



82618



50012616

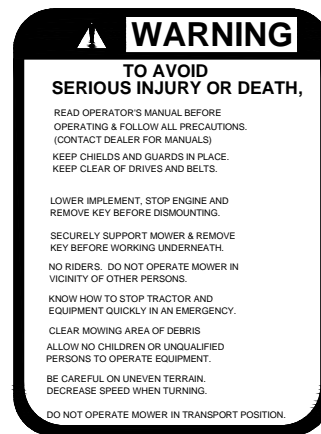

82617



60873



83056

DECALS CONTINUED

! **WARNING**



IMPLEMENT CAN FALL FROM HYDRAULIC SYSTEM FAILURE. TO AVOID SERIOUS INJURY OR DEATH,

- ★ BLOCK UP OR SECURELY SUPPORT IMPLEMENT BEFORE WORKING UNDERNEATH.
- ★ PURGE ALL AIR FROM HYDRAULIC SYSTEM BEFORE ATTEMPTING TO RAISE OR LOWER THIS IMPLEMENT.
- ★ DO NOT USE HAND OR SKIN TO CHECK FOR HYDRAULIC LEAKS. USE CARDBOARD OR WOOD.
- ★ DO NOT USE HAND OR SKIN TO CHECK FOR HYDRAULIC LEAKS. USE CARDBOARD OR WOOD.
- ★ HIGH PRESSURE OIL LEAKS CAN PENETRATE SKIN CAUSING SERIOUS INJURY AND GANGRENE. CONSULT A PHYSICIAN IMMEDIATELY.
- ★ LOWER THE IMPLEMENT AND RELEASE HYDRAULIC PRESSURE BEFORE LOOSENING FITTINGS.
- ★ REFER TO OWNERS MANUAL FOR DETAILS.

82683

! **WARNING**



TO AVOID SERIOUS INJURY AND DEATH,

- ★ DO NOT OPERATE WITH WINGS RAISED.
- ★ LOCK WINGS UP FOR TRANSPORT.
- ★ STAND CLEAR IF LOWERING OR RAISING WINGS.
- ★ DECREASE SPEED WHEN TURNING, BE CAREFUL ON SLOPES OR UNEVEN TERRAIN WITH WINGS IN RAISED POSITION.
- ★ BE ALERT TO OVERHEAD OBSTRUCTIONS AND ELECTRICAL WIRES WITH WINGS IN THE RAISED POSITION.

83105

TORQUE SPECIFICATIONS

Proper torque for American fasteners used on Locke Turf equipment.
Recommended Torque in Foot Pounds (Newton Meters). *

AMERICAN Bolt Head Markings

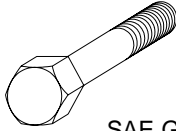

SAE Grade 2
(No Dashes)

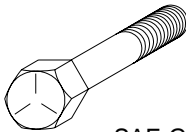

SAE Grade 5
(3 Dashes)

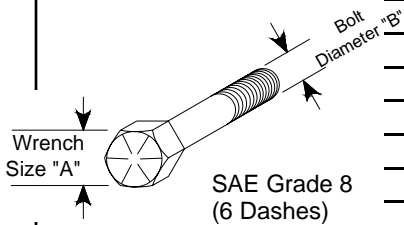

SAE Grade 8
(6 Dashes)

WRENCH SIZE (IN.) "A"	BOLT DIAMETER (IN.) "B" AND THREAD SIZE	SAE GRADE 2	SAE GRADE 5	SAE GRADE 8
7/16	1/4 -20 UNC	6 (7)	8 (11)	12 (16)
7/16	1/4 -28 UNF	6 (8)	10 (13)	14 (18)
1/2	5/16 - 18 UNC	11 (15)	17 (23)	25 (33)
1/2	5/16 - 24 UNF	13 (17)	19 (26)	27 (37)
9/16	3/8 - 16 UNC	20 (27)	31 (42)	44 (60)
9/16	3/8 - 24 UNF	23 (31)	35 (47)	49 (66)
5/8	7/16 - 14 UNC	32 (43)	49 (66)	70 (95)
5/8	7/16 - 20 UNF	36 (49)	55 (75)	78 (106)
3/4	1/2 - 13 UNC	49 (66)	76 (103)	106 (144)
3/4	1/2 - 20 UNF	55 (75)	85 (115)	120 (163)
7/8	9/16 - 12 UNC	70 (95)	109 (148)	153 (207)
7/8	9/16 - 18 UNF	79 (107)	122 (165)	172 (233)
15/16	5/8 - 11 UNC	97 (131)	150 (203)	212 (287)
15/16	5/8 - 18 UNF	110 (149)	170 (230)	240 (325)
1-1/8	3/4 - 10 UNC	144 (195)	266 (360)	376 (509)
1-1/8	3/4 -16 UNF	192 (260)	297 (402)	420 (569)
1-5/16	7/8 - 9 UNC	166 (225)	430 (583)	606 (821)
1-5/16	7/8 - 14 UNF	184 (249)	474 (642)	668 (905)
1-1/2	1 -8 UNC	250 (339)	644 (873)	909 (1232)
1-1/2	1 - 12 UNF	274 (371)	705 (955)	995 (1348)
1-1/2	1 - 14 UNF	280 (379)	721 (977)	1019 (1381)
1-11/16	1-1/8 - 7 UNC	354 (480)	795 (1077)	1288 (1745)
1-11/16	1-1/8 - 12 UNF	397 (538)	890 (1206)	1444 (1957)
1-7/8	1-1/4 - 7 UNC	500 (678)	1120 (1518)	1817 (2462)
1-7/8	1-1/4 - 12 UNF	553 (749)	1241 (1682)	2013 (2728)
2-1/16	1-3/8 - 6 UNC	655 (887)	1470 (1992)	2382 (3228)
2-1/16	1-3/8 - 12 UNF	746 (1011)	1672 (2266)	2712 (1992)
2-1/4	1-1/2 - 6 UNC	870 (1179)	1950 (2642)	3161 (4283)
2-1/4	1-1/2 - 12 UNF	979 (1327)	2194 (2973)	3557 (4820)

Proper torque for American fasteners used on Locke Turf equipment.
Recommended Torque in Foot Pounds (Newton Meters). *

METRIC

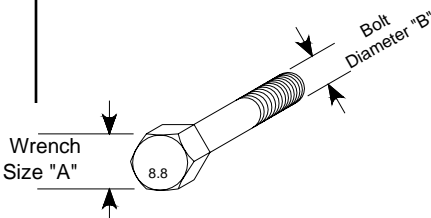

Numbers appearing on bolt heads
Indicate ASTM class.

*Use 75% of the specified torque value
for plated fasteners. Use 85% of the
specified torque values for lubricated
fasteners.

WRENCH SIZE (mm) "A"	BOLT DIA. (mm) "B"	ASTM 4.6	ASTM 8.8	ASTM 9.8	ASTM 10.9
8	5	1.8 (2.4)		5.1 (6.9)	6.5 (8.8)
10	6	3 (4)		8.7 (12)	11.1 (15)
13	8	7.3 (10)		21.1 (29)	27 (37)
16	10	14.5 (20)		42 (57)	53 (72)
18	12	25 (34)	74 (100)	73 (99)	93 (126)
21	14	40 (54)	118 (160)	116 (157)	148 (201)
24	16	62 (84)	167 (226)	181 (245)	230 (312)
30	20	122 (165)	325 (440)		449 (608)
33	22		443 (600)		611 (828)
36	24	211 (286)	563 (763)		778 (1054)
41	27		821 (1112)		1138 (1542)
46	30	418 (566)	1119 (1516)		1547 (2096)

LOCKE TURF BLADE SPINDLE SERVICE

BLADE SPINDLE DISASSEMBLY

1. Using **safety gloves**, hold the lower blade and remove the 1/2" x 1-3/4" capscrew, Belleville washer, blade and shaft washer.
2. Remove the (4) 3/8" capscrews holding the upper disc assembly to the blade carrier. Lift the disc assembly and shaft bushing off the spindle shaft.
3. Support the spindle housing in a press with the blade carrier turned up. Press the inner shaft top bearing and upper sheave out. (Figure 3)
4. Remove the 5/8" locknut from the inner shaft and press the sheave off.
5. Remove the woodruff key and top bearing.



CAUTION
USE SAFETY EYE PROTECTION
WHEN USING HAMMER AND
PUNCH TO PREVENT FLYING
PARTICLES FROM INJURING
EYES.

6. Using a blunt punch: unstage sheave from upper end of outer shaft and unstage blade carrier from lower end of outer shaft. (Use care so as not to damage the threads.) (Figure 4)

Figure 2

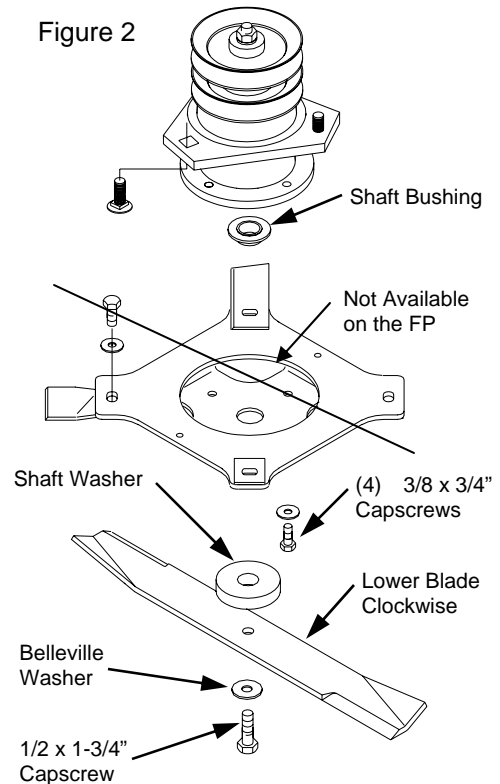
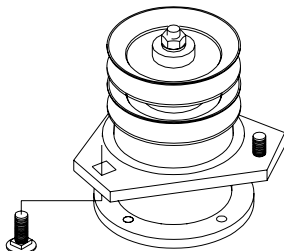

Figure 4



7. Using two 3/8" x 3/4" UNC threads Grade 8 capscrews, bolt the carrier wrench to the blade carrier. (Wrench Kit 50026073) (Figure 5)

8. Put the spindle in the upright position and place the blade carrier wrench in a vise and secure it. (Figure 5)

THE CARRIER WRENCH AND SHEAVE WRENCH REFERRED TO IN THESE INSTRUCTIONS ARE CONTAINED IN WRENCH KIT 50026073.

Figure 5

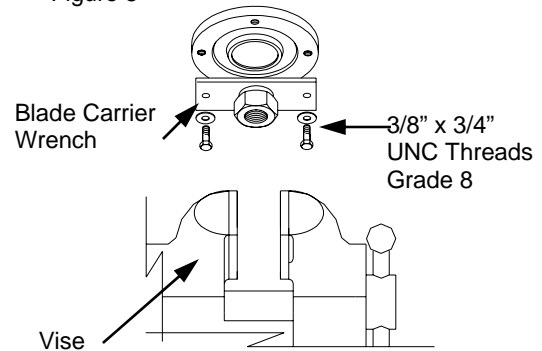

9. Place the sheave wrench on the sheave, aligning the two studs with the two holes in the sheave. (Wrench Kit 5002073) THESE THREADS ARE LEFT HANDED. TO LOOSEN, TURN CLOCKWISE. Remove sheave. (Figure 6)

10. Remove spindle from vise and place the housing in a press with the blade carrier turned down. Press the outer shaft, lower bearing and blade carrier out.

11. Place the outer shaft in a vise and remove the blade carrier. THESE THREADS ARE LEFT HANDED. TO LOOSEN, TURN CLOCKWISE. (Figure 7) You may have to heat shaft to loosen; if so, remove inner bearing first.

12. Press the bearing off the shaft.

13. Using a punch on a flat surface, drive the top outer bearing from the housing.

Figure 6

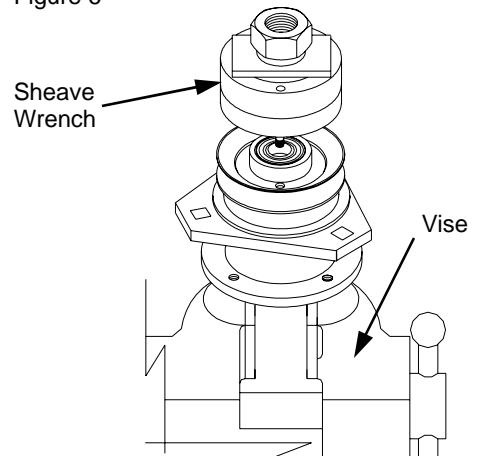
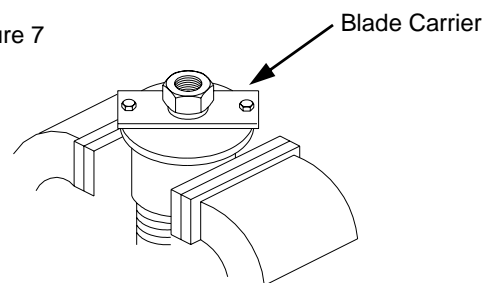
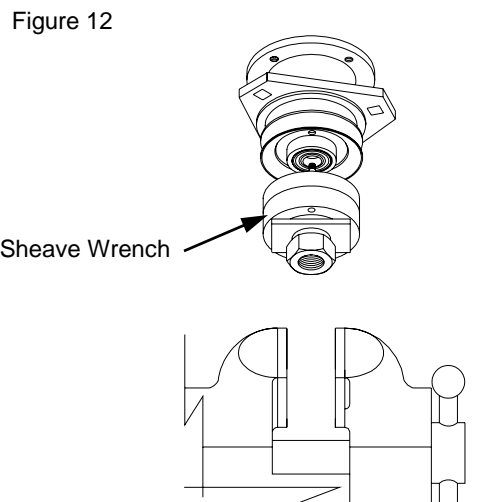
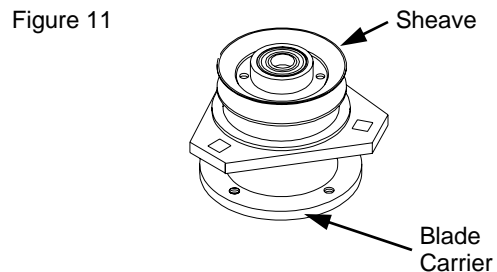
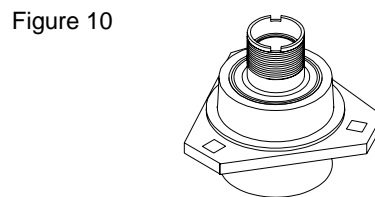
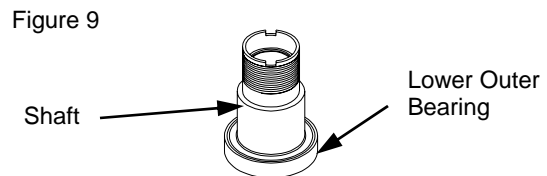
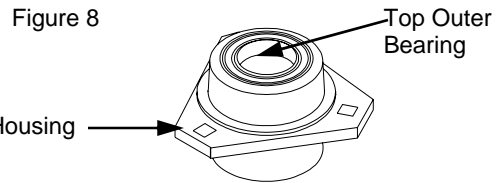

Figure 7



BLADE SPINDLE ASSEMBLY

1. Press the outer bearing in the housing until the bearing bottoms out. (Figure 8)
2. Press the lower outer bearing on the shaft until it bottom out. (Figure 9)
3. Place the outer shaft and lower bearing through the hub into the top outer bearing. Press together until both outer bearing races bottom out on housing and shaft. (Figure 10)
4. Press the inner bearing into the top of the outer shaft. (Figure 10)
5. Thread the blade carrier and the sheave on the outer shaft. (Figure 11)
6. Attach the blade carrier wrench to the blade carrier (Figure 5). Put the spindle in the upright position and place the blade carrier wrench in a vise and secure it.
7. Use the sheave wrench (Figure 6). Turn counterclockwise and tighten sheave to 200 ft.lbs.
8. Remove spindle from vise. Place the sheave wrench in the vise and secure it. (Figure 12) Place the spindle sheave on the sheave wrench and



- Remove the blade carrier wrench and restake the blade carrier into the notch of the outer shaft. (Figure 13)

⚠ CAUTION ⚠

**USE SAFETY EYE PROTECTION
WHEN USING HAMMER AND PUNCH
TO PREVENT FLYING PARTICLES
FROM INJURING EYES.**

- Restake the drive sheave into the notch of the outer shaft. (Figure 13)
- Press the bottom inner bearing on the lower end of the inner shaft. (Figure 14)

Figure 13

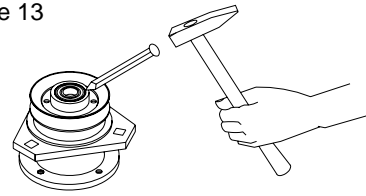
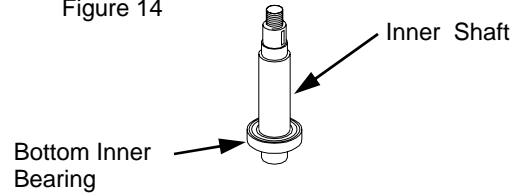
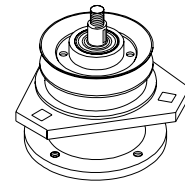

Figure 14



- Place the inner shaft and lower bearing through the outer shaft and top inner bearing. Press together until the top bearing has bottomed out on the shaft and the bottom bearing has bottomed out in the outer shaft. The top and bottom bearings will be recessed in the outer shaft. (Figure 15)
- Install the Woodruff key, sheave, flatwasher and nut onto the inner shaft. TORQUE NUT TO 76 FT.LBS.

Figure 15



NOTE

Before installing upper blade assembly, install the three 1/2" x 1-1/2" carriage bolts into the spindle housing. (Figure 16)

Figure 16

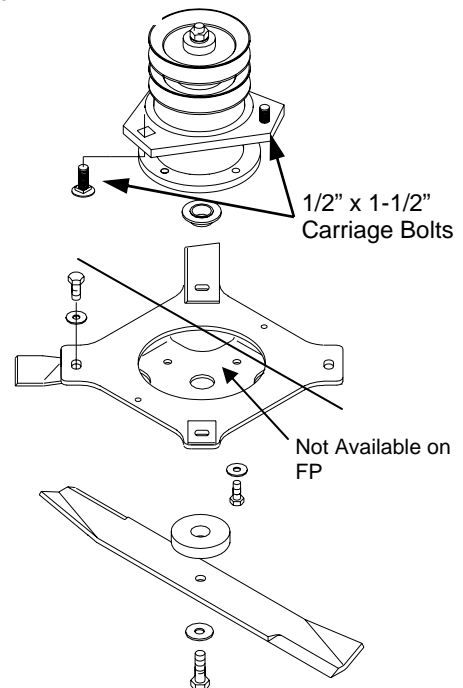

- Place the shaft bushing on the spindle shaft. Using the (4) 3/8" x 3/4" capscrews and Belleville washer, bolt the blade assembly to the blade carriers. TORQUE TO 32 FT.LBS.
- Using safety gloves, install the shaft washer, lower blade, Belleville washer and blade bolt onto the inner shaft. TORQUE TO 76 FT.LBS.

NOTES:



Locke Turf Inc.

307 Highway 52E, Opp, Alabama 36467, (334) 493-1300

Free Manuals Download Website

<http://myh66.com>

<http://usermanuals.us>

<http://www.somanuals.com>

<http://www.4manuals.cc>

<http://www.manual-lib.com>

<http://www.404manual.com>

<http://www.luxmanual.com>

<http://aubethermostatmanual.com>

Golf course search by state

<http://golfingnear.com>

Email search by domain

<http://emailbydomain.com>

Auto manuals search

<http://auto.somanuals.com>

TV manuals search

<http://tv.somanuals.com>