



Verticutter Mower TVM-3077 and TVM-5130



Parts Manual

Locke Turf

307 Highway 52E, Opp, Alabama 36467, (334) 493-1300

TVM 3077 & TVM 5130 VERTI - CUTTER

INDEX

SECTION DESCRIPTION	SECTION
Mainframe and Related Parts	1
Guards	2
Drives, Gearboxes, Belts, Driveshafts	3
Wheels, Axles, Hubs	4
Hydraulics	5
Mowing Units	6
Decals	7

PART DESCRIPTION	PAGE
Belt Idler	3-9
Compensator, Single	1-5
Dual	1-6
Cutter Head, TVM 3077	6-2, 6-3
Cutter Head, TVM 5130	6-4, 6-5
Adjusting Wheel	6-1
Decals	7-1, 7-2
Driveshaft, C.V.	3-5
Front Jackshaft	3-6
Rear Jackshaft, TVM 5130	3-7
Rear Jackshaft, TVM 3077	3-8
Gearbox and Sheaves, TVM 5130	3-1, 3-2
TVM 3077	3-3, 3-4
Guards, Primary	2-1
V-Belt, TVM 5130	2-2
V-Belt, TVM 3077	2-3
Hydraulic System, TVM 5130	5-1
TVM 3077	5-2
Lift Assembly TVM 5130	1-2
TVM 3077	1-4
Mainframe TVM 3077	1-1
TVM 5130	1-3
Wheel, Axle, Hub Assembly	4-1

(Note HHCS = Hex Head Cap Screw)

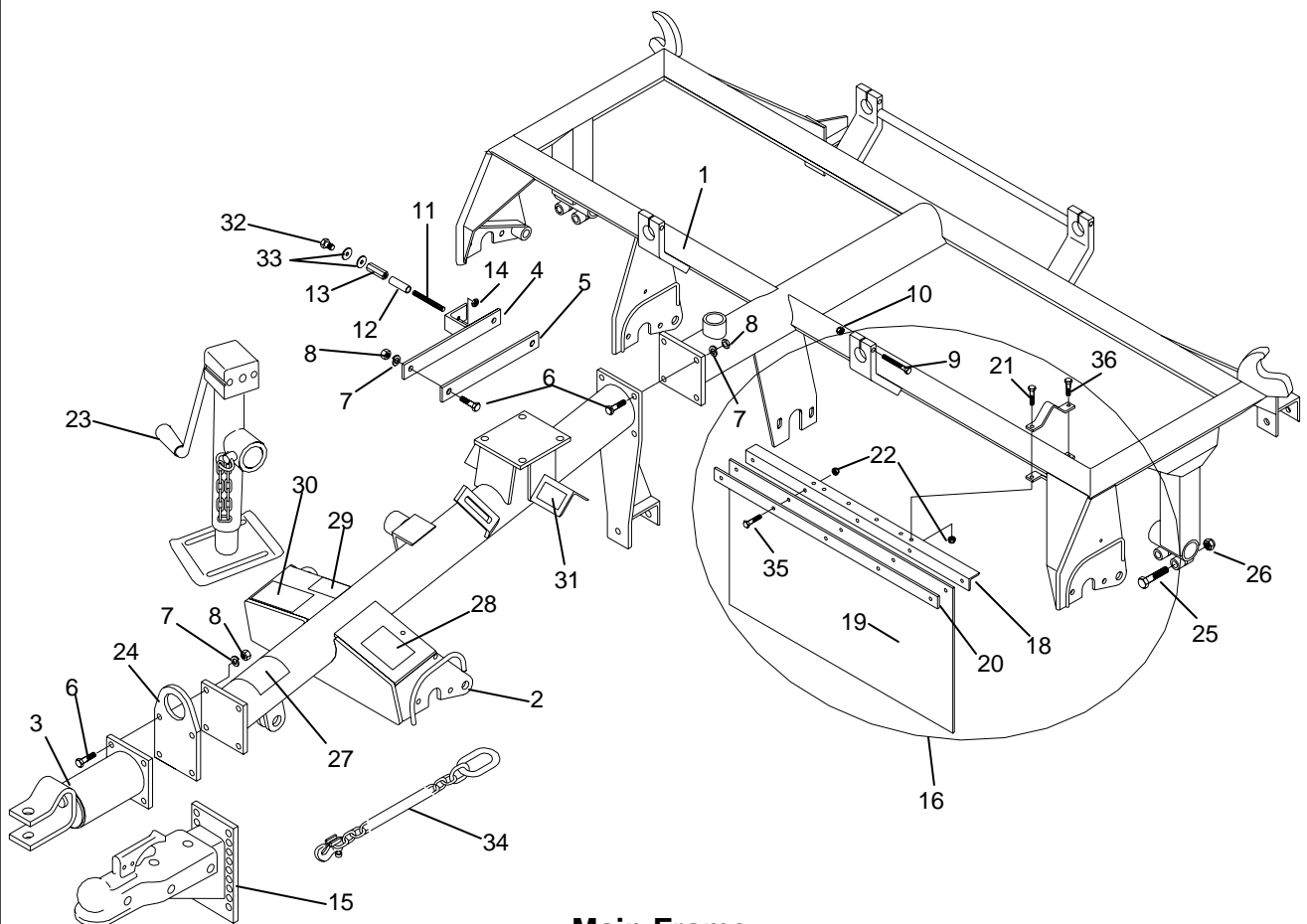

**Main Frame
TVM 5130 Verti Cutter**

REF. NO.	PART NO.	QTY	DESCRIPTION	REF. NO.	PART NO.	QTY	DESCRIPTION
1	50022306	1	Mainframe	19	50022367	2	Deflector
2	50022176	1	Tongue W/Decals	20	50022366	2	Clamp Bar
3	50019541	1	Swivel	21	20011	4	HHCS 5/16"-18 x 1-1/2" Gr.5
4	50019888	1	Tongue Brace, RH	22	44553	18	Hex Nut-Nylock 5/16"-18
5	50019938	1	Tongue Brace, LH	23	50022109	1	Jackstand Assy.
6	15093	8	HHCS 1/2"-13 x 1-1/2" Gr.5	24	50019877	1	Hose Holder Assy.
7	15806	8	Lock washer 1/2"	25	19065	4	HHCS 1/2"-13 x 2-1/2" Gr.5
8	8151600	8	Hex Nut 1/2"	26	44539	4	Hex Nut-Nylock 1/2"-13
9	19055	4	HHCS 3/8"-16 x 3" Gr.5	27	50022073	1	Warning Decal
10	8151200	3	Hex Nut-Nylock 3/8"-16	28	50022081	1	Notice Decal
11	50019944	1	Stud, Belt Guard	29	50022067	1	Decal, Flag
12	50019942	1	Spacer, RH Shield	30	50022070	1	Warning Decal
13	44600	1	Nut, Coupling 3/8"-16 x 1-3/4"	31	50022066	2	Danger Decal
14	10151200	1	Hex Nut, Jam 3/8-16	32	44721	1	HHCS 3/8"-16 c 3/4"
15	50019542	1	Ball Hitch Assy.	33	15830	2	Flatwasher 3/8"
16	50022369	2	Deflector Assembly (17-22)	34	91091	1	Safety Tow Chain
17	50022236	4	Deflector Clamp				
18	50022235	2	Mounting Angle				

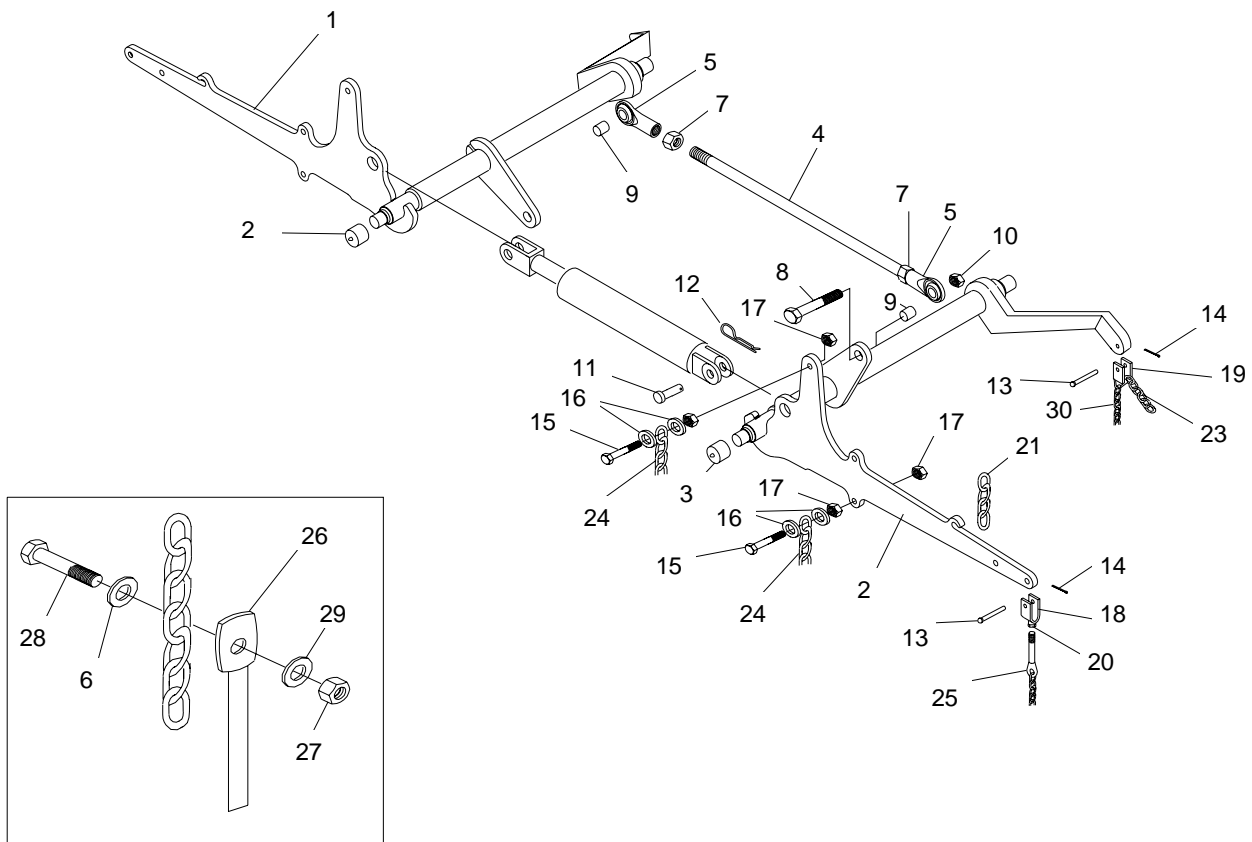

TVM 5130 Equalizer and Lift Arm Assembly

REF. PART NO.	QTY	DESCRIPTION	REF. PART NO.	QTY	DESCRIPTION		
1	50022328	1	Lift Arm (5 Gang) LH	17	10151200	6	Jam Nut 3/8"-16
2	50022329	1	Lift Arm (5 Gang) RH	18	50019916	2	Clevis Yoke w/ Hole
3	50019948	4	Bearing Cup Assy.	19	50019915	2	Clevis Yoke.
4	50019873	1	Synchronizing Rod	20	8151200	2	Hex Nut 3/8"-16
5	50019872	2	Rod End RH 3/4"-16F 3/4" Bore	21	50019952	2	Transport Lock Chain
6	50019644	12	Fender Washer 1/4" x 1"	22	50019949	1	Lift Chain #1
7	44606	2	Jam Nut 3/4"-16	23	50019893	2	Lift Chain #2 & #3 Outer
8	19021	2	HHCS 3/4"-10 x 3" Gr.5	24	50019950	2	Lift Chain #4 & #5 Inner
9	50019914	2	Spacer	25	50019895	2	Lift Chain #4 & #5 Outer
10	19517	2	Hex Nut 3/4"-10	26	50022099	4	Polly Strap 9"
11	50019659	2	Clevis Pin 1" x 2-3/4"	50022100	2	Polly Strap 15"	
12	1273	2	Presto Pin 3/16"	27	44566	12	Nylock Hex Nut 1/4"-20
13	25H49039	4	Clevis Pin 3/8" x 1-1/2"	28	44579	12	HHCS 1/4"-20 x 1-1/2" Gr.5
14	21020510	4	Cotter Pin 5/32" x 1"	29	15918	12	Flatwasher 1/4"
15	44174	4	HHCS 3/8"-16 x 1-3/4"	30	50019939	2	Lift Chain #2 & #3 Inner
16	15830	8	Flatwasher 3/8"				

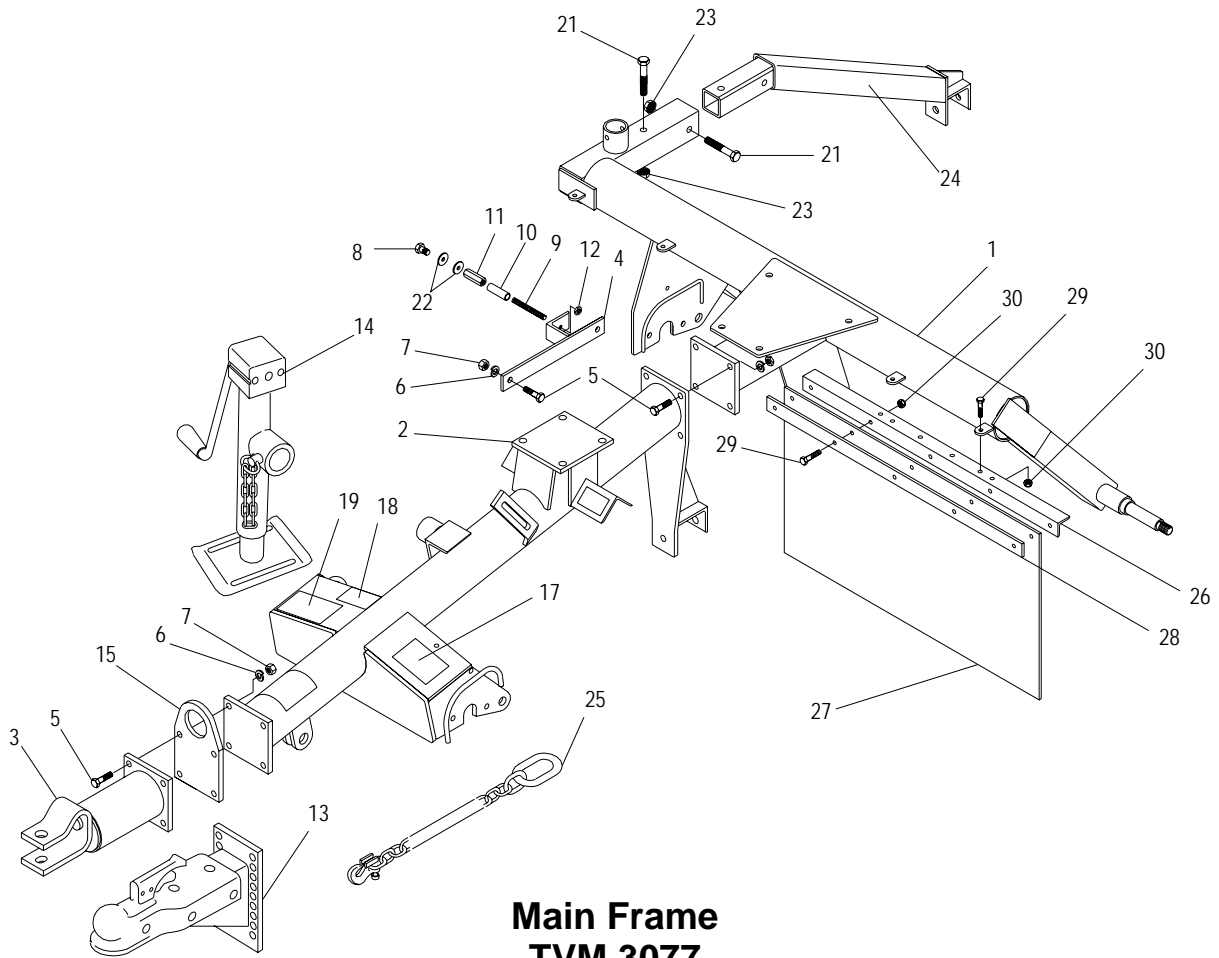

Main Frame TVM 3077

REF. NO.	PART NO.	QTY	DESCRIPTION	REF. NO.	PART NO.	QTY	DESCRIPTION
1	50022352	1	Mainframe	16	50022073	1	Warning Decal
2	50022176	1	Tongue W/Decals	17	50022081	1	Notice Decal
3	50019541	1	Swivel	18	50022067	1	Decal, Flag
4	50019888	1	Tongue Brace, RH	19	50022070	1	Warning Decal
5	15093	10	HHCS 1/2"-13 x 1-1/2" Gr.5	20	50022066	2	Danger Decal
6	15806	10	Lock washer 1/2"	21	20864	1	HHCS 1/2"-13 x 3" Gr.5
7	8151600	10	Hex Nut 1/2"	22	15830	2	Flatwasher 3/8"
8	44721	1	HHCS 3/8"-16 x 3/4" Gr.5	23	44615	2	Whiz Nut 1/2"-13
9	50019944	1	Stud, Belt Guard	24	50022355	1	Compensator Arm
10	50019942	1	Spacer, RH Shield	25	91091	1	Safety Tow Chain
11	44600	1	Nut, Coupling 3/8"-16 x 1-3/4"	26	50022235	2	Mounting Angle
12	10151200	1	Hex Nut, Jam 3/8"-16	27	50022367	2	Deflector
13	50019542	1	Ball Hitch Assy.	28	50022366	2	Clamp Bar
14	50022109	1	Jackstand Assy.	29	15086	18	HHCS 5/16"-18 x 1-1/4" Gr.5
15	50019877	1	Hose Holder Assy.	30	44553	18	Hex Nut - Nylock 5/16"-18

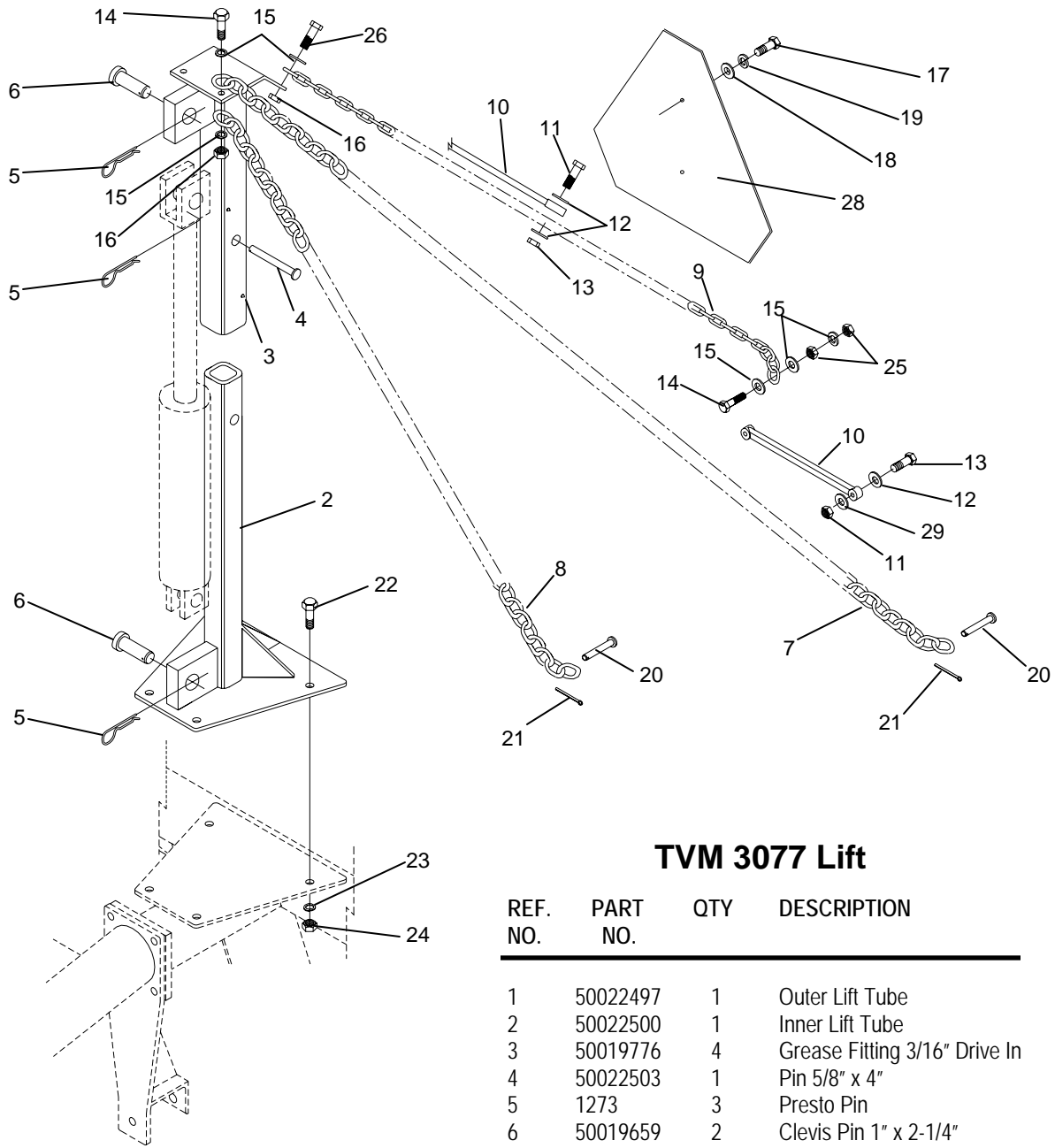

TVM 3077 Lift

REF. NO.	PART NO.	QTY	DESCRIPTION
19	25H49039	4	Pin 3/8" x 1-3/4"
20	21020510	4	Cotter Pin 5/32" x 1"
21	15093	4	HHCS 1/2" x 1-1/2" Gr.5
22	15806	4	Lockwasher 1/2"
23	8151600	4	Hex Nut 1/2"
24	10151200	4	Jam Nut 3/8"
25	20035	2	HHCS 3/8" x 1/2"
26	15812	2	Lockwasher 3/8"
27	50019854	1	SMV Sign
28	50019644	8	Fender Washer 1/4" x 1"

REF. NO.	PART NO.	QTY	DESCRIPTION
1	50022497	1	Outer Lift Tube
2	50022500	1	Inner Lift Tube
3	50019776	4	Grease Fitting 3/16" Drive In
4	50022503	1	Pin 5/8" x 4"
5	1273	3	Presto Pin
6	50019659	2	Clevis Pin 1" x 2-1/4"
7	50022337	2	Lift Chain - Outer Front
8	50022336	2	Lift Chain - Inner Front
9	50022335	2	Lift Chain - Rear
10	50022099	3	Strap, Rubber 8.25" Long
11	20016	6	HHCS 1/4" x 1-1/2"
12	15918	12	Flatwasher 1/4"
13	44539	6	Hex Nut 3/8" Nylock
14	44181	4	HHCS 3/8"
15	15830	10	Flatwasher 3/8"
16	44601	4	Hex Nut 3/8" -Nylock
17	1161006	2	HHCS 5/16" x 3/4" Gr.5
18	15907	2	Flatwasher 5/16"
19	15808	2	Lockwasher 5/16"
20	25H49039	4	Pin 3/8" x 1-3/4"

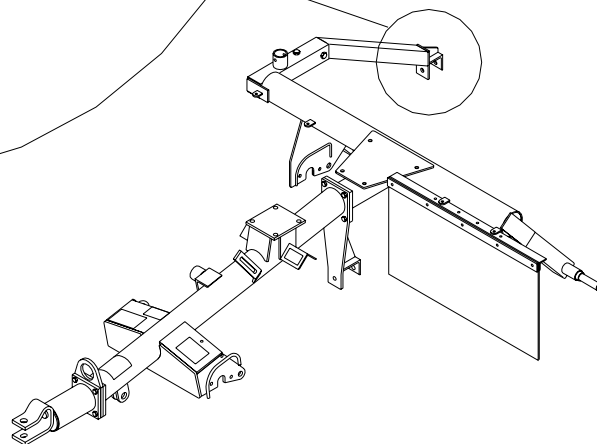
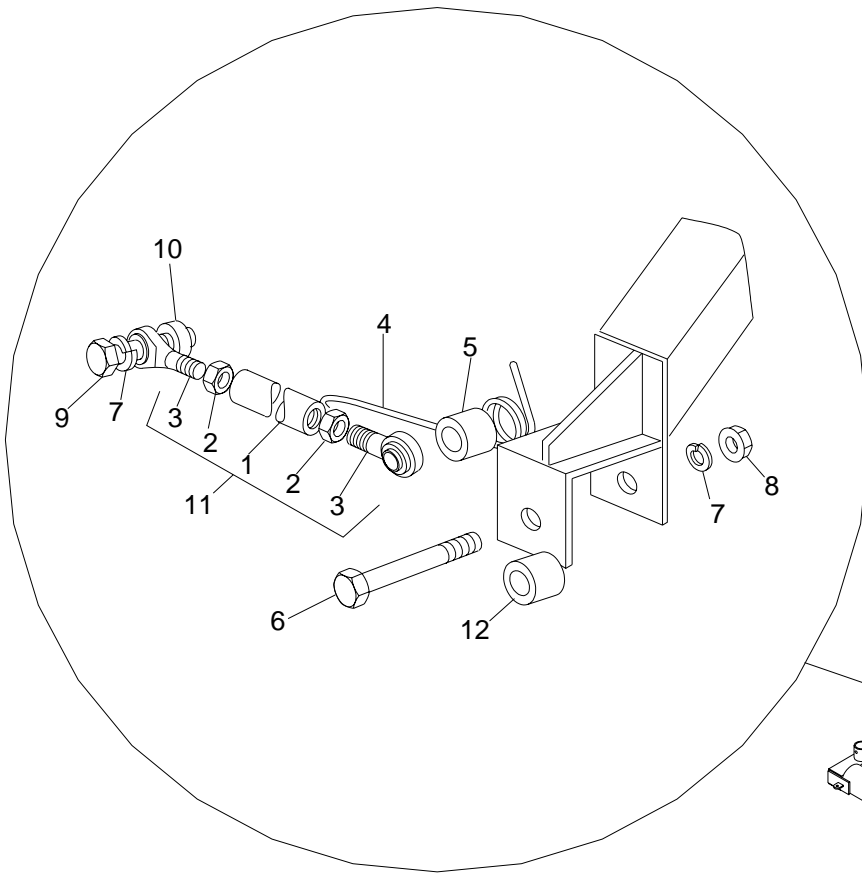

Single Compensator and Tie Rod Assemblies

Reel Unit No. 4 (TVM-5130)

Reel Unit No. 1 (TVM-3077)

REF. NO.	PART NO.	QTY	DESCRIPTION
1	50019910	1	Tie Rod
2	44743	1	Hex Nut 5/8"-18 UNF RH Thd
	44710	1	Hex Nut 5/8"-18 UNF LH Thd
3	50019870	1	Rod End 5/8" Bore w/Rh Thread 5/8"-18
	50019868	1	Rod End 5/8" Bore w/LH Thread 5/8"-18
4	50022083	1	Compensator Spring 1/4"
5	50019940	1	Spacer 7/8" Thick
6	44168	1	HHCS 5/8"-11 x 3-3/4" Gr.5
7	19486	1	Lockwasher 5/8"
8	15563	1	Hex Nut 5/8"-11
9	20947	1	HHCS 5/8"-11 x 2" Gr.5
10	50019875	1	Tie Rod Spacer
11	50019911	1	Tie Rod Assy.
12	50019941	1	Spacer 5/8" Thick

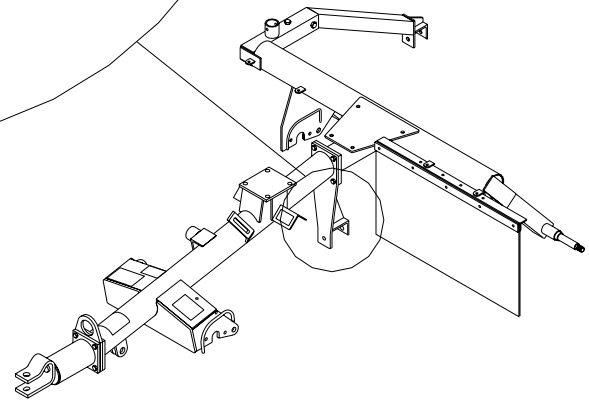
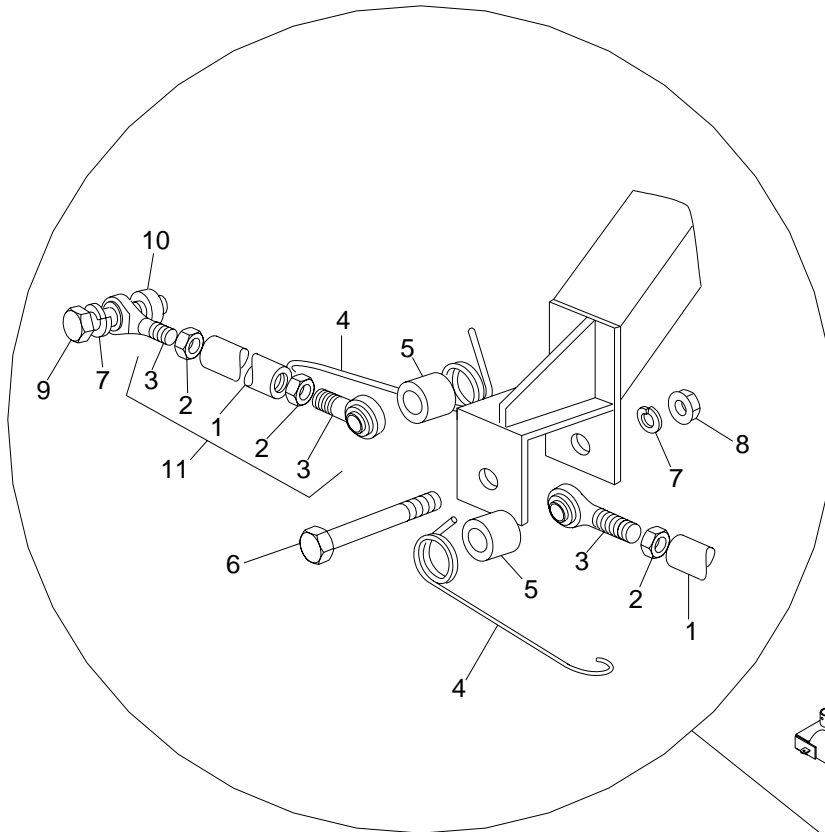

Dual Compensator and Tie Rod Assemblies

Reel Unit No. 4 (TVM-5130)
 Reel Unit No. 1 (TVM-3077)

REF. NO.	PART NO.	QTY	DESCRIPTION
1	50019910	1	Tie Rod
2	44743	1	Hex Nut 5/8"-18 UNF RH Thd
	44710	1	Hex Nut 5/8"-18 UNF LH Thd
3	50019870	1	Rod End 5/8" Bore w/Rh Thread 5/8"-18
	50019868	1	Rod End 5/8" Bore w/LH Thread 5/8"-18
4	50022083	1	Compensator Spring 1/4"
5	50019940	1	Spacer 7/8" Thick
6	44625	1	HHCS 5/8"-11 x 4-3/4" Gr.5
7	19486	1	Lockwasher 5/8"
8	15563	1	Hex Nut 5/8"-11
9	20947	1	HHCS 5/8"-11 x 2" Gr.5
10	50019875	1	Tie Rod Spacer
11	50019911	1	Tie Rod Assy.

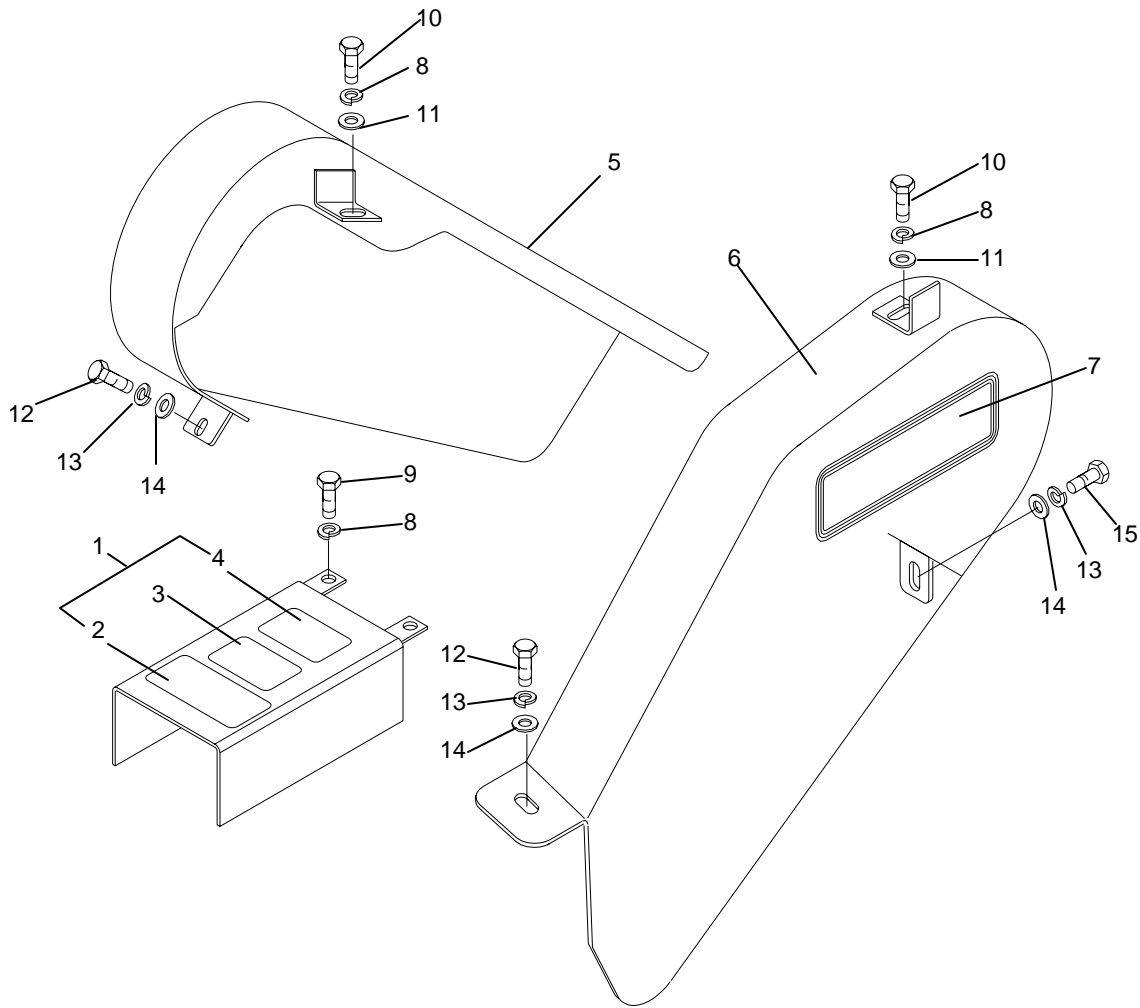

Primary Guards

REF. NO.	PART NO.	QTY	DESCRIPTION
1	50022175	1	Guard w/Decals - Driveshaft
2	50022072	1	Danger Decal
3	50022074	1	Decal - Notice to Owner
4	50022065	1	Danger Decal (Spanish)
5	50019968	1	R.H. Drive Guard
6	50019971	1	L.H. Drive Guard
7	50100034	2	Model Decal TVM-5130
	50100033	2	Model Decal TVM-3077
8	15806	4	Lockwasher 1/2"
9	44588	2	HHCS 1/2"-13 x 3/4" Gr.5
10	20054	2	HHCS 1/2"-13 x 1" Gr.5
11	15829	2	Flatwasher 1/2"
12	20035	2	HHCS 3/8"-16 x 1/2"
13	15812	3	Lockwasher 3/8"
14	15830	3	Flatwasher 3/8"
15	1161006	1	HHCS 5/16"-18 x 3/4"

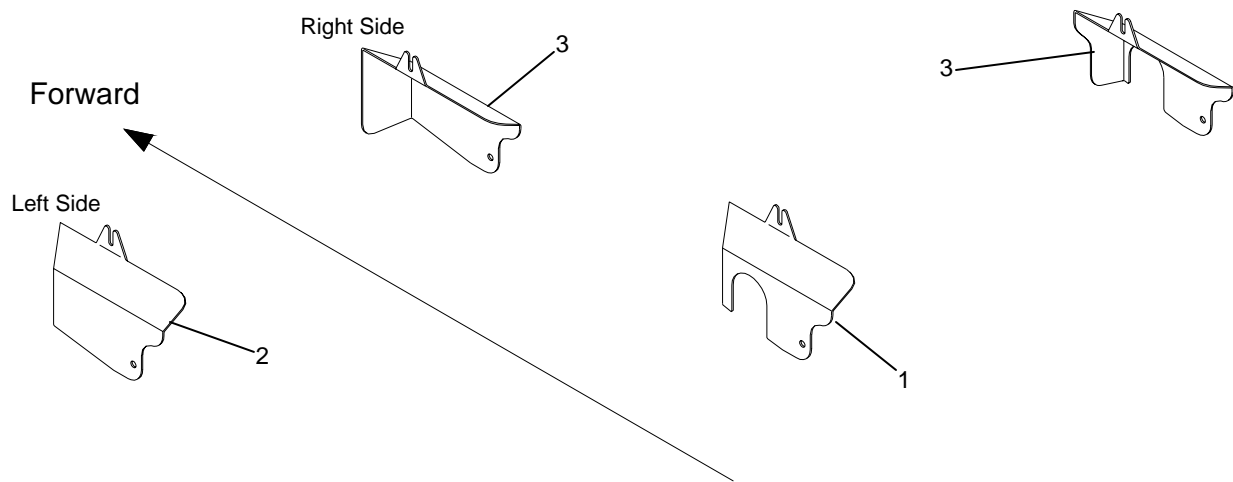

V-Belt Guards TVM-5130

REF. NO.	PART NO.	QTY	DESCRIPTION
1	50019931	1	Guard, Center Rear #1
2	50019933	2	Guard, L.H. Outside #2 & #4
3	50019934	2	Guard, R.H. Outside #3 & #5
4	1161006	5	HHCS 5/16"-18 x 3/4"
5	15801	5	Lockwasher 5/16"
6	15907	5	Flatwasher 5/16"
7	20009	5	HHCS 1/4"-20 x 1/2"
8	15905	5	Lockwasher 1/4"
9	15918	5	Flatwasher 1/4"

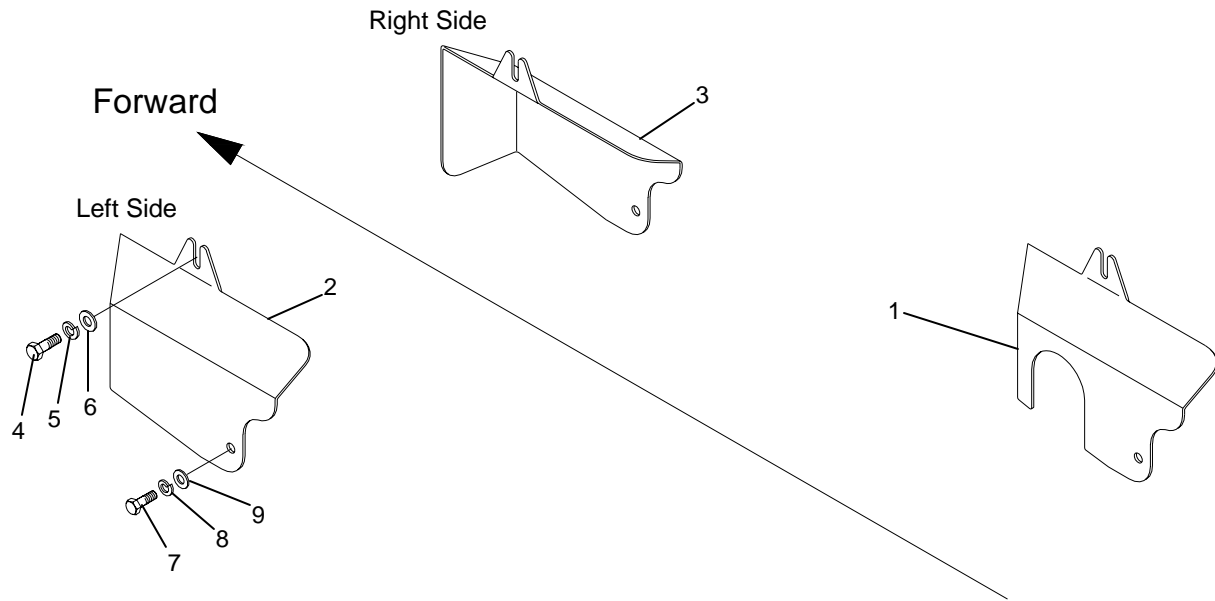

V-Belt Guards TVM-3077

REF. NO.	PART NO.	QTY	DESCRIPTION
1	50019931	1	Guard, Center Rear #1
2	50019933	1	Guard, L.H. Outside #2 & #4
3	50019934	1	Guard, R.H. Outside #3 & #5
4	1161006	5	HHCS 5/16"-18 x 3/4"
5	15801	5	Lockwasher 5/16"
6	15907	5	Flatwasher 5/16"
7	20009	5	HHCS 1/4"-20 x 1/2"
8	15905	5	Lockwasher 1/4"
9	15918	5	Flatwasher 1/4"

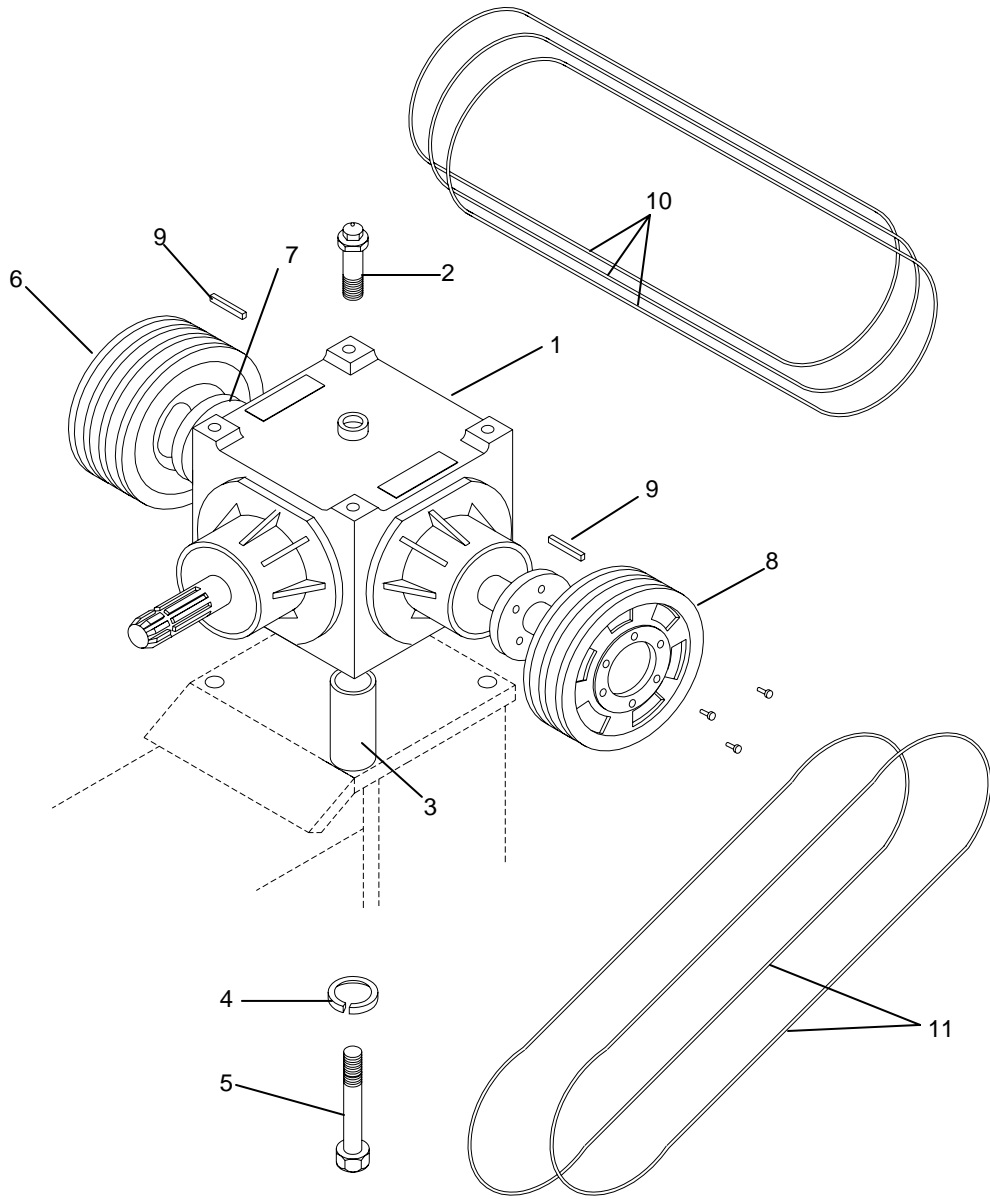

Gearbox & Sheaves TVM-5130

REF. NO.	PART NO.	QTY	DESCRIPTION
1	50022102	1	Gearbox Assy. (Comer) TVM-50
2	50022324	1	Vent Plug
3	50019943	1	Spacer, Gearbox
4	15806	4	Lockwasher 1/2"
5	20864	4	HHCS 1/2"-13 x 3" Gr.5
6	50022420	1	Pulley, 3 Belt 7" Dia.
7	50022107	2	Bushing, Tapered Split SK 1-1/8"
8	50022085	3	Pulley, 2 Belt 7" Dia.
9	65485	2	Key 2"
10	50022450	3	"V"-Belt BX-78
11	50022451	2	"V"-Belt BX-70

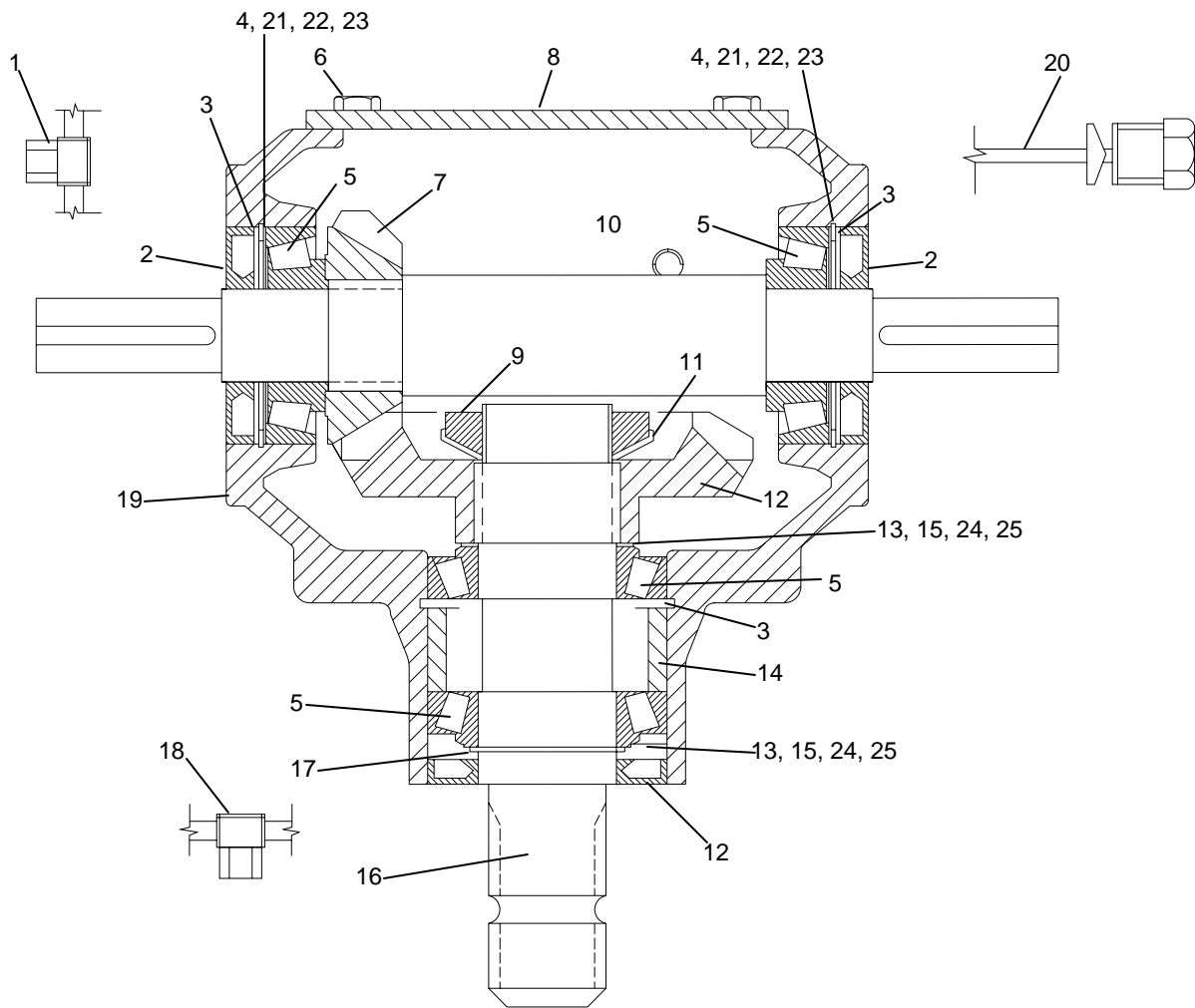

50022102 Gearbox Assembly
TVM-5130
Manufactured by Comer

REF. NO.	PART NO.	QTY	DESCRIPTION	REF. NO.	PART NO.	QTY	DESCRIPTION
1	70292	1	Oil Plug 3/8"	14	50022321	1	Spacer
2	70108	3	Oil Seal 35 x 72 x 10mm	15	70331	2	Shim 35.3 x 48 x .5
3	70133	3	Snap Ring 72 UNI7437	16	50022322	1	Shaft 1-3/8"
4	70642	2	Shim 60.3 x 71.7 x 1	17	70841	1	Snap Ring 35
5	70797	4	Bearing 30207	18	F7502880	1	Plug 1/4"
6	70903	4	Bolt M8 x 14 Gr.8.8	19	50022323	1	Casing
7	50022316	1	Pinion Z15 M5.7	20	50022324	1	Oil Level Plug
8	50022317	1	Cover	21	70639	2	Shim 60.3 x 71.7 x .3
9	70470	1	Locknut M35 x 1.5	22	70640	2	Shim 60.3 x 71.7 x .4
10	50022318	1	Shaft	23	70641	2	Shim 60.3 x 71.7 x .5
11	50022319	1	Spring Washer	24	70329	2	Shim 35.3 x 48 x .3
12	50022320	1	Crown Wheel Z22 M5.7	25	70330	2	Shim 35.3 x 48 x .4
13	70332	2	Shim 35.3 x 48 x 1.3				

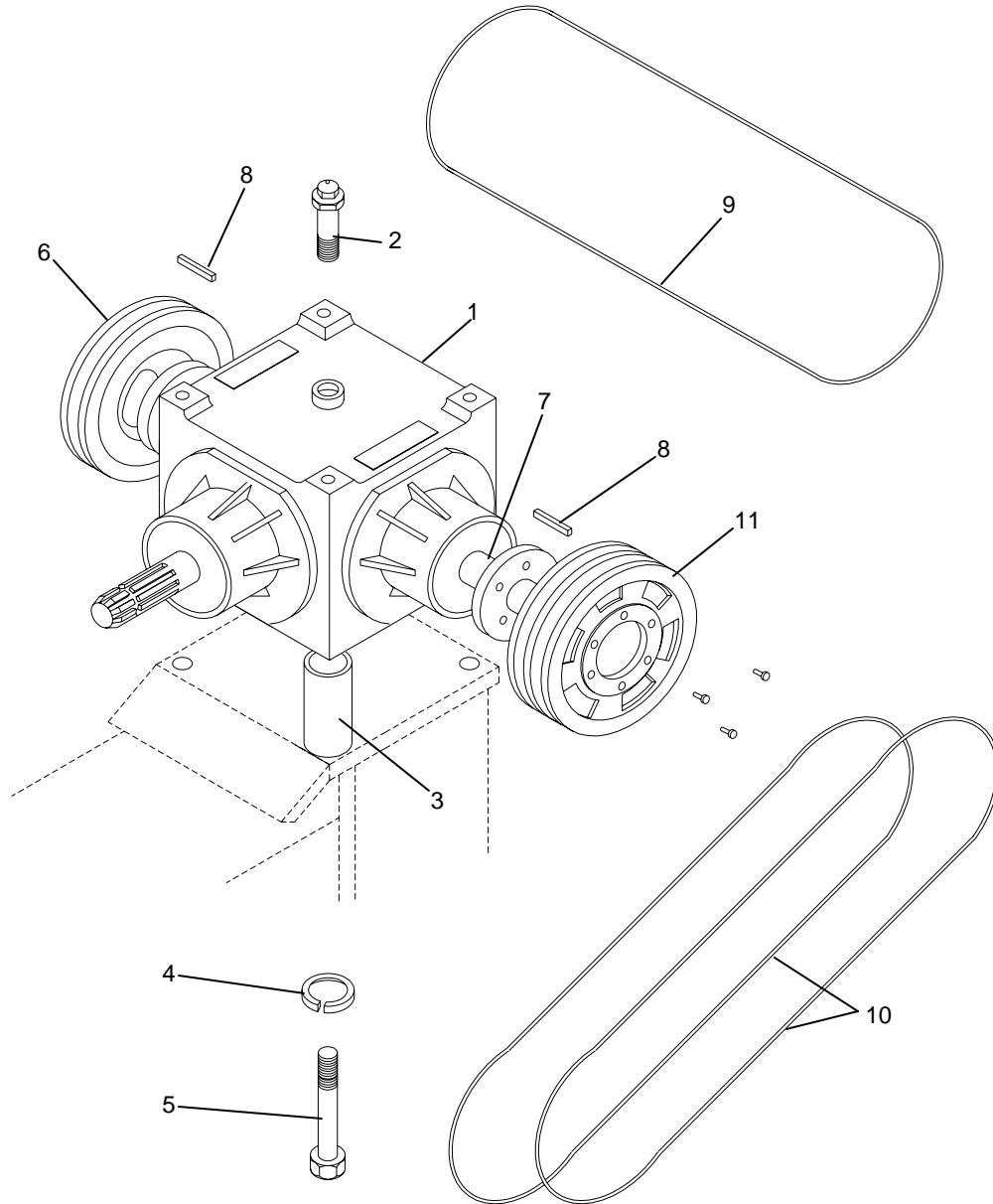

Gearbox & Sheaves TVM-3077

REF. NO.	PART NO.	QTY	DESCRIPTION
1	50019729	1	Gearbox Assy. (Omni) TVM-3077
2	50022324	1	Vent Plug
3	50019943	1	Spacer, Gearbox
4	15806	4	Lockwasher 1/2"
5	20864	4	HHCS 1/2"-13 x 3" Gr.5
6	50022086	1	Pulley, 1 Belt 7" Dia.
7	50022108	2	Bushing, Tapered Split SDS 1-1/8"
8	65485	2	Key 2"
9	50022450	3	"V"-Belt BX-78
10	50022451	2	"V"-Belt BX-70
11	50022085	1	Pulley, 2 Belt, 7" Dia.

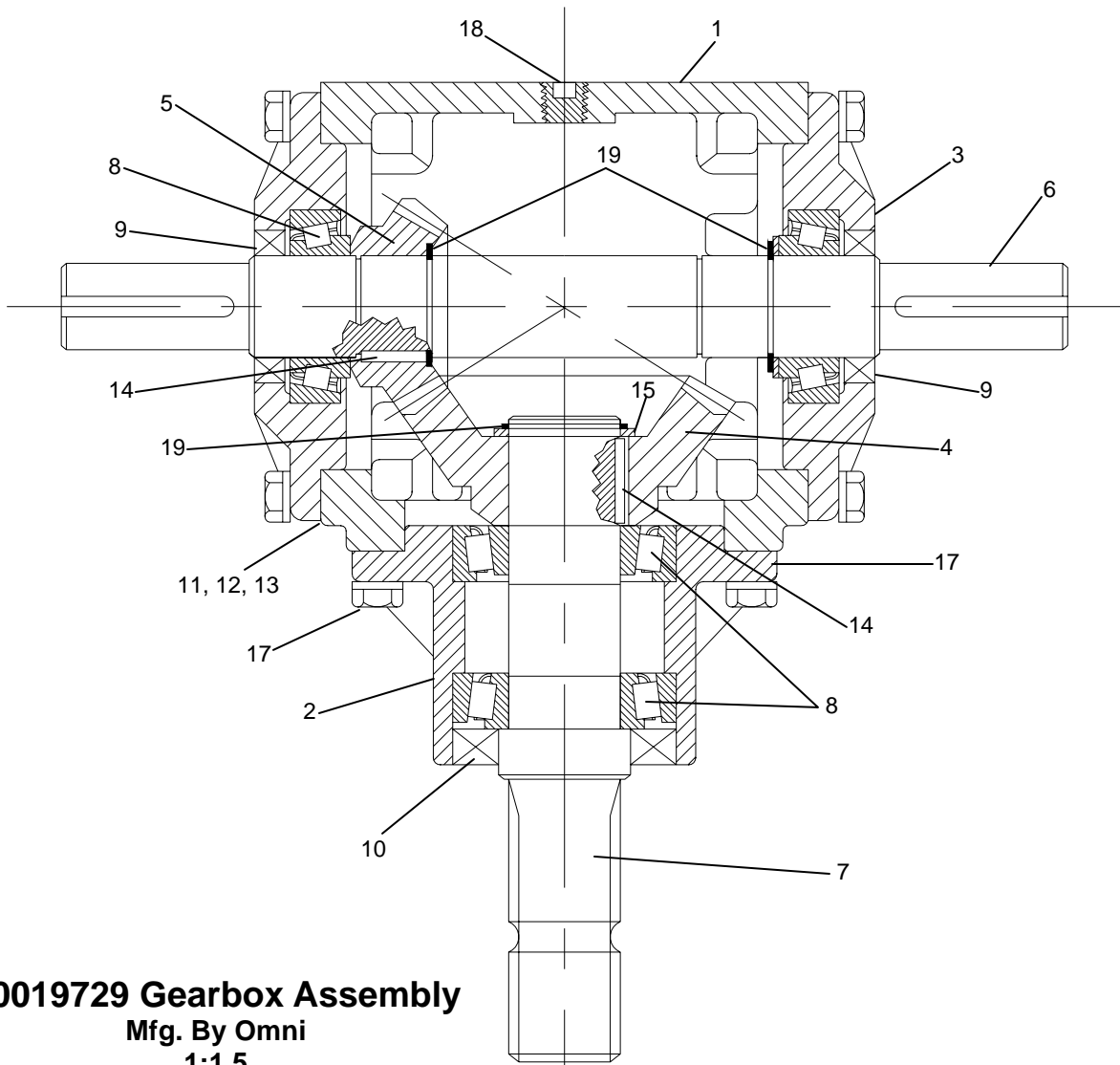

50019729 Gearbox Assembly
Mfg. By Omni
1:1.5
1-3/8"-6 Spline Input Shaft
TVM-3077

REF. NO.	PART NO.	QTY	DESCRIPTION	REF. NO.	PART NO.	QTY	DESCRIPTION
1	50022476	1	Housing	11	50022487	A/R	Gasket, Cap, 0.1
2	50022477	1	Cap, Cantilevered	12	50022488	A/R	Gasket, Cap, 0.2
3	50022478	2	Cap, Thru	13	50022489	A/R	Gasket, Cap, 0.3
4	50022479	1	Gear, 24T	14	50022490	2	Key, Square 10 x 25mm
5	50022480	1	Pinion, 16T	15	50022491	2	Spacer
6	50022481	1	Shaft, Output	16	1161010	24	HHCS 5/16" x 1" Gr.5
7	50022482	1	Shaft, Input	17	15808	24	Lockwasher 5/16"
8	70797	4	Bearing, 30207	18	78719	2	Plug, Socket Hd. 1/2"-14 NPTF
9	50022485	2	Seal, Thru Cap	19	50022493	4	Retaining
10	50022486	1	Seal, Cant. Cap				

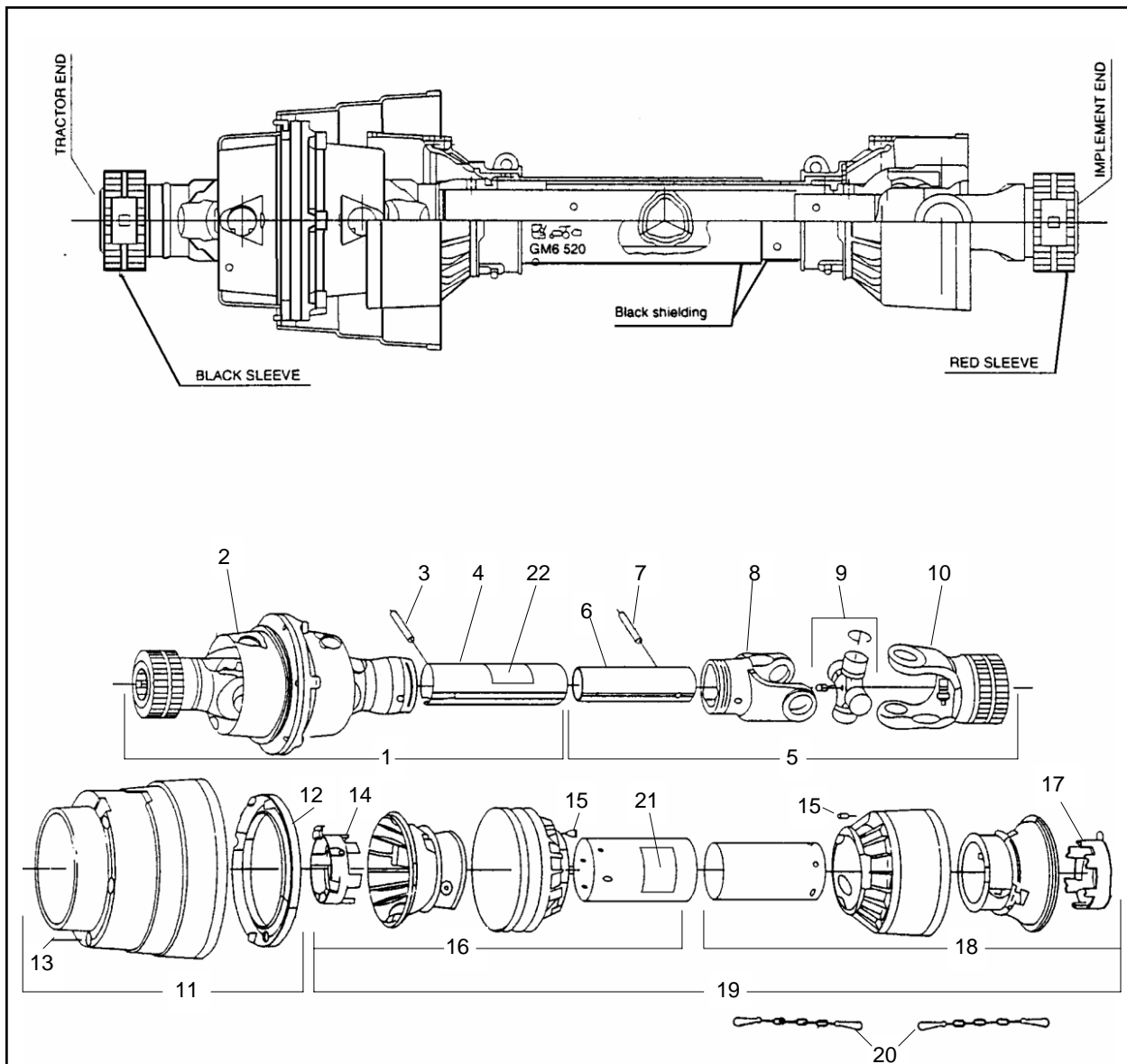

50022104 P.T.O. Shaft and Parts

REF. NO.	PART NO.	QTY	DESCRIPTION	REF. NO.	PART NO.	QTY	DESCRIPTION
1	50022676	1	Half Shaft, Outer	12	50022686	1	Bearing, Soft Cone
2	50022677	1	CV Joint Assembly	13	50022687	6	Screw, Self Tapping
3	50022678	1	Roll Pin 8mm x 65mm	14	50022688	1	Bearing, Shield Tube Outer
4	50022679	1	Outer Tube	15	50022669	2	Lock Pin
5	50022680	1	Half Shaft, Inner	16	50022675	1	Outer Half Shaft Shield
6	50022681	1	Inner Tube	17	50022689	1	Bearing, Shield Tube, Inner
7	50022682	1	Roll Pin 8mm x 55mm	18	50022690	1	Inner Half Shaft Shield
8	50022692	1	Yoke, Inner Tube	19	50022691	1	Complete Shield
9	64694	1	Cross Bearing Kit	20	50022673	3	Safety Chain
10	50022684	1	Yoke, Implement End	21	78608	1	Danger Decal
11	50022685	1	Wide Angle Shield	22	78786	1	Danger Decal

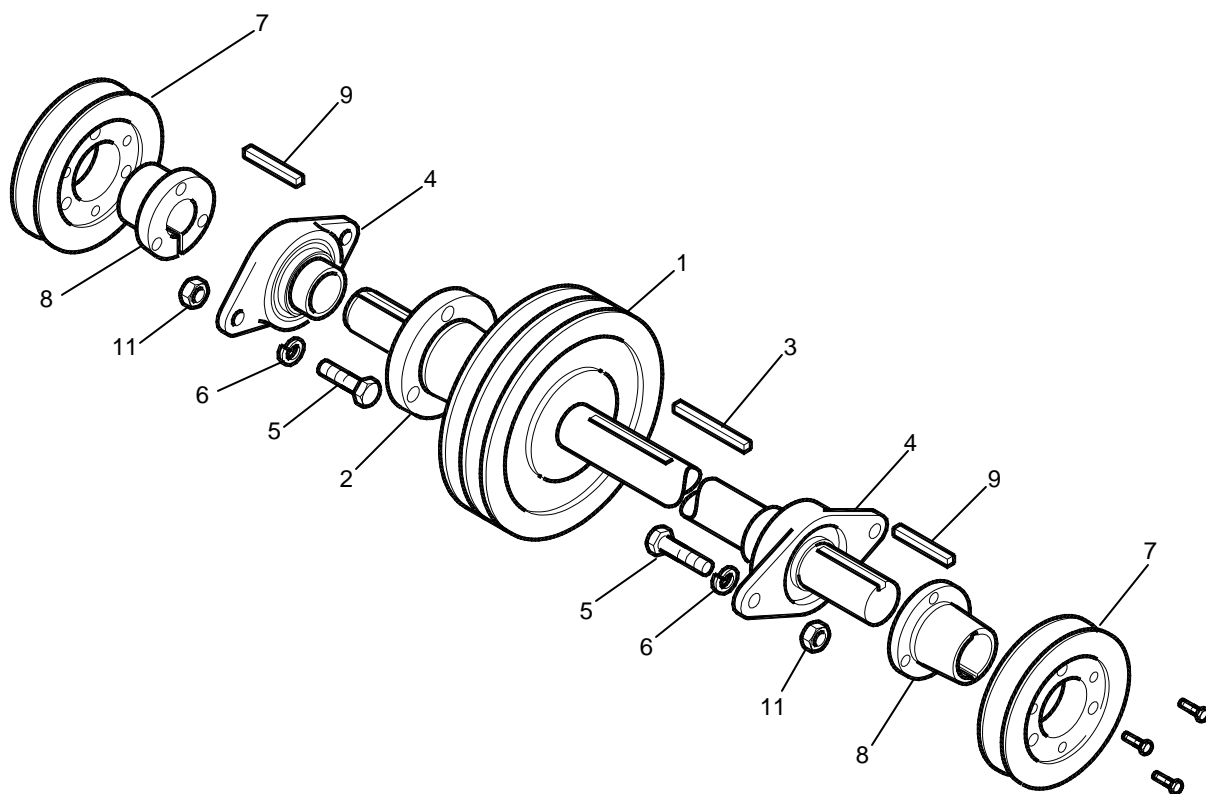

Front Jackshaft Assembly TVM-5130 & TVM-3077

REF. NO.	PART NO.	QTY	DESCRIPTION
1	50022087	1	Pulley 2 Belt 6.6PD
2	50022106	1	Bushing Split Taper SDS 1"
3	65484	1	Key 2"
4	50022101	2	Bearing 1" 2 Hole Flange
5	44614	4	HHCS 7/16"-14 x 1-1/4" Gr.5
6	15819	4	Lockwasher 7/16"
7		2	Pulley 1 Belt 4.4 PD
8	50022105	2	Bushing Split Taper SH 1"
9	93810	2	Key 1" x 1/4"
10	50019878	1	Front Jackshaft
11	8151400	4	Hex Nut 7/16"-14 Gr.5

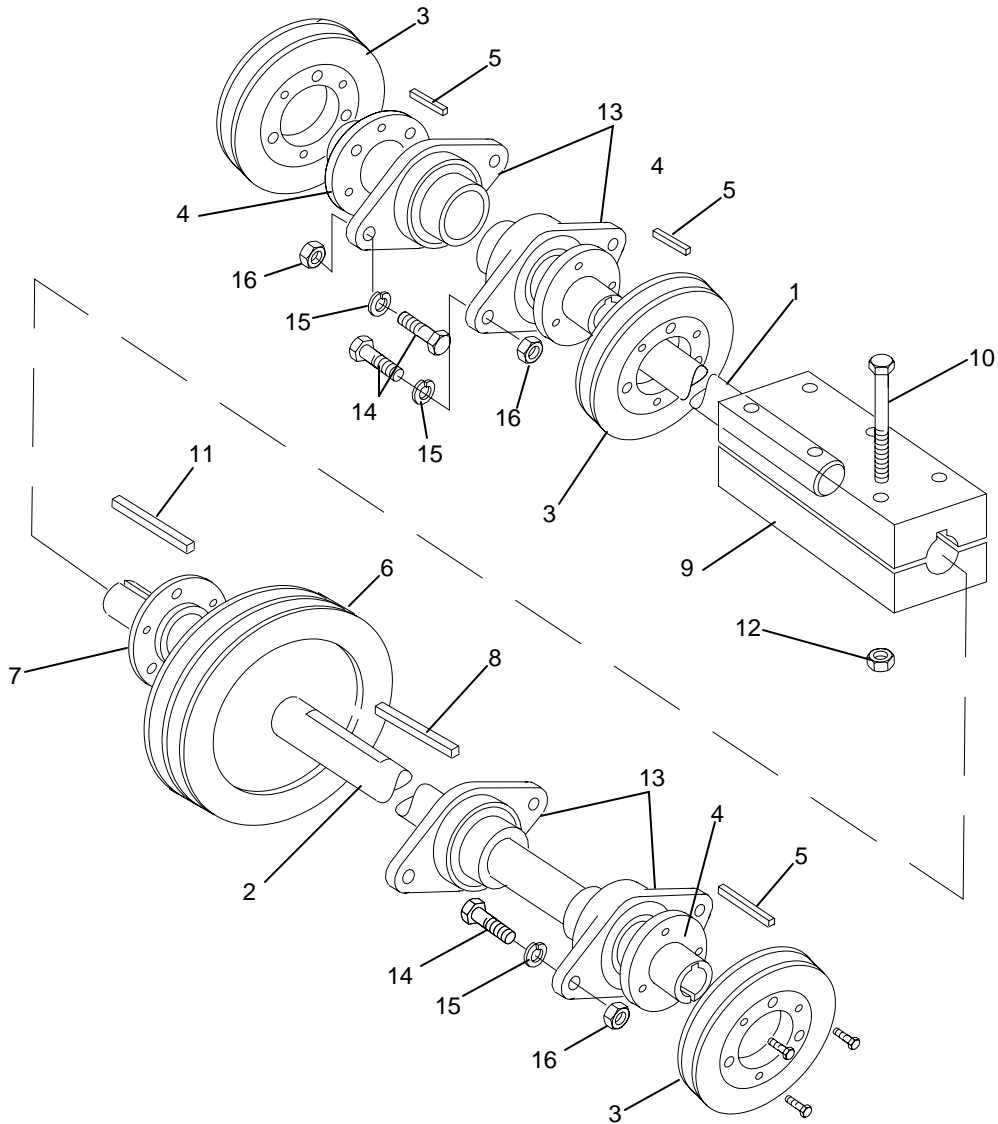

Rear Jackshaft Assembly

REF. NO.	PART NO.	QTY	DESCRIPTION	REF. NO.	PART NO.	QTY	DESCRIPTION
1	50022327	1	RH Rear Jackshaft	9	50019999	1	Jackshaft Coupling Assy.
2	50019883	1	LH Rear Jackshaft	10	20504	6	HHCS 5-16"-18 x 2-1/2"
3	50022084	3	Pulley, 1 Belt 4.4 PD	11	50019885	1	Key 5"
4	50022105	1	Bushing, Split Taper SH 1"	12	44553	6	Hex Nut, Nylock 5/16"-18
5	93810	5	Key 1" x 1/4"	13	50022101	3	Bearing 1", 2 Bolt Flange
6	50022419	1	Pulley, 3 Belt 6.6 PD	14	44614	6	HHCS 7/16"-14 x 1-1/4"
7	50022428	1	Bushing, Split Taper SD 1"	15	15819	6	Lockwasher 7/16"
8	50019884	1	3" Key	16	8151400	6	Hex Nut 7/16"-14

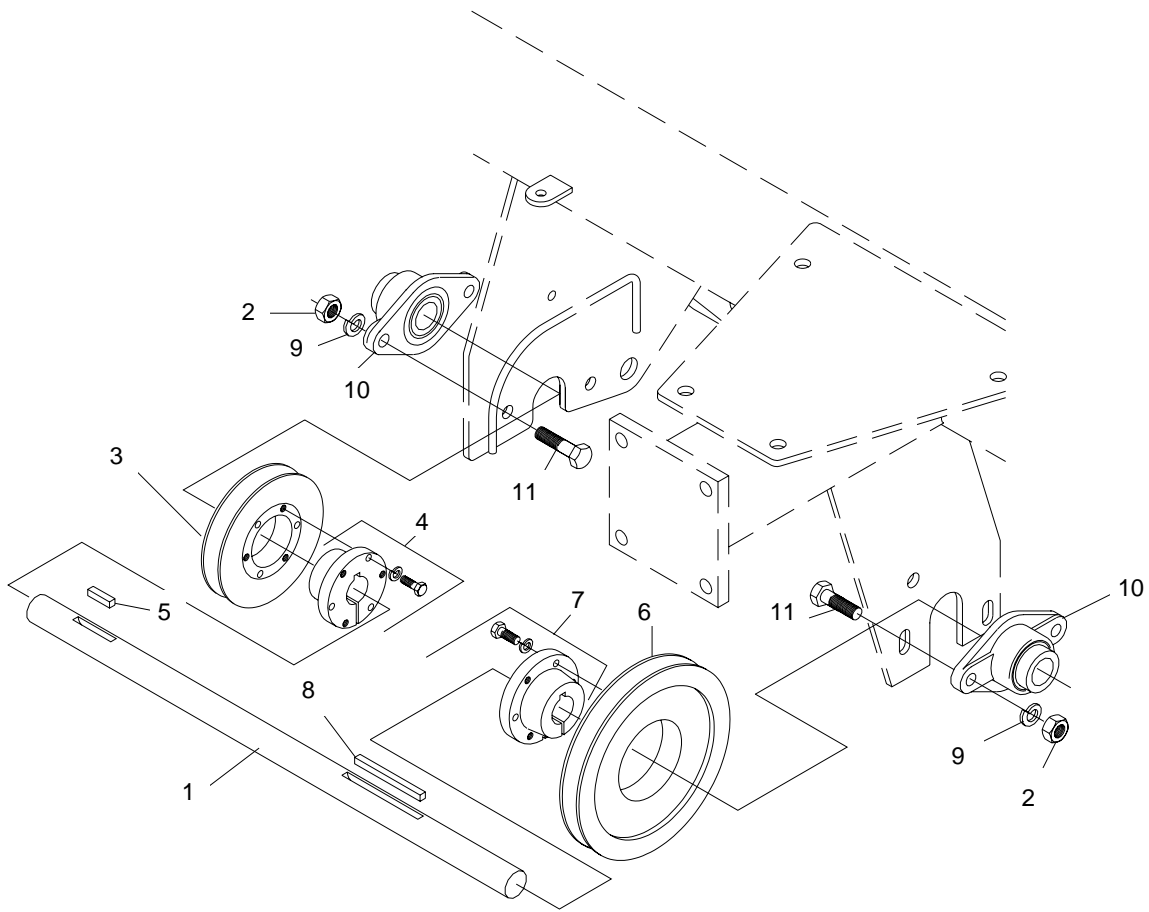

Rear Jackshaft Assembly

REF. NO.	PART NO.	QTY	DESCRIPTION
1	50022334	1	Jackshaft, Rear-3 Gang
2	8151400	4	Hex Nut 7/16"-14 Gr5
3	50022084	1	Pulley, 1 Belt 4.4" PD
4	50022105	1	Bushing, Split Taper SH 1"
5	93810	1	Key 1/4" x 1/4" x 1"
6	50022088	1	Pulley, 1 Belt 6.6" PD
7	50022106	1	Bushing, Split Taper SDS 1"
8	50019884	1	Key 1/4" x 1/4" x 3"
9	44618	4	Lockwasher 7/16"
10	50022101	2	Bearing, 2 Bolt Flange 1" Bore
11	15012	4	HHCS 7/16"-14 x 1-1/2"

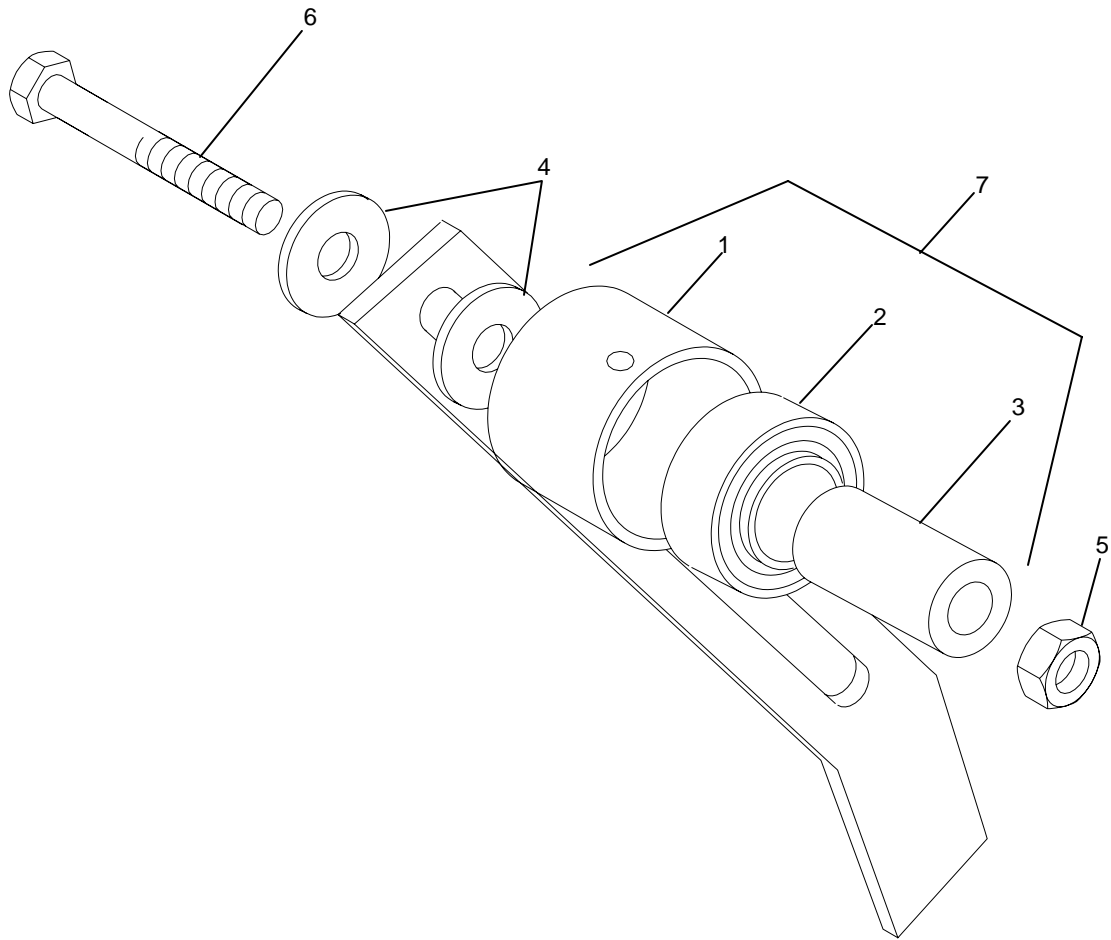

Belt Idler Assembly

REF. NO.	PART NO.	QTY	DESCRIPTION
1	50019889	1	Idler Shell 2-1/2"
	50019912	1	Idler Shell 2"
2	50019890	1	Bearing, 1" ID x 52 mm OD
3	50019891	1	Bushing 1" OD x 2"
4	15829	2	Flatwasher 1/2"
5	44539	1	Nylock Hex Nut 1/2"-13
6	20864	1	HHCS 1/2"-13 x 3" Gr.5
7	50019892	1	Belt Drive Idler Assy. 2-1/2"
	50019913	1	Belt Drive Idler Assy. 2"

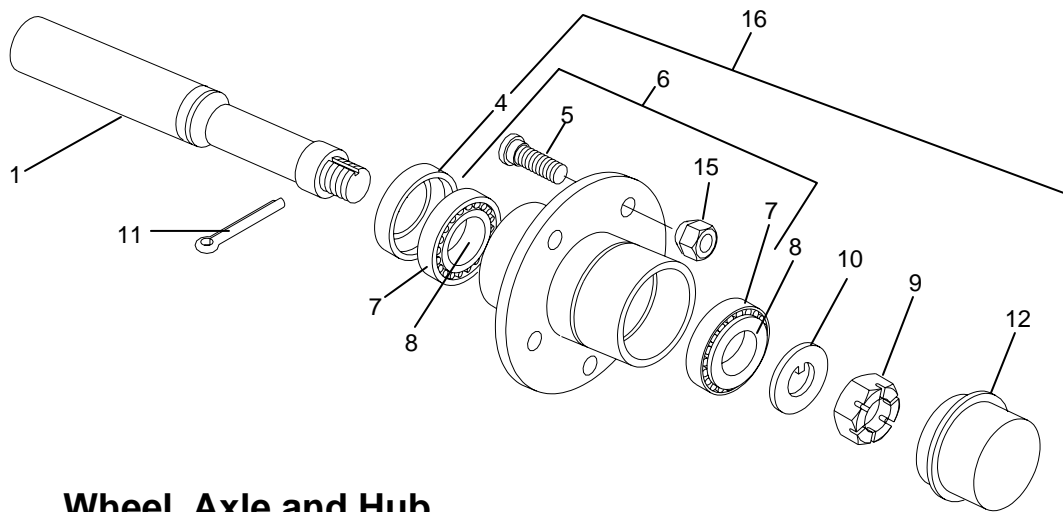

Wheel, Axle and Hub Assembly

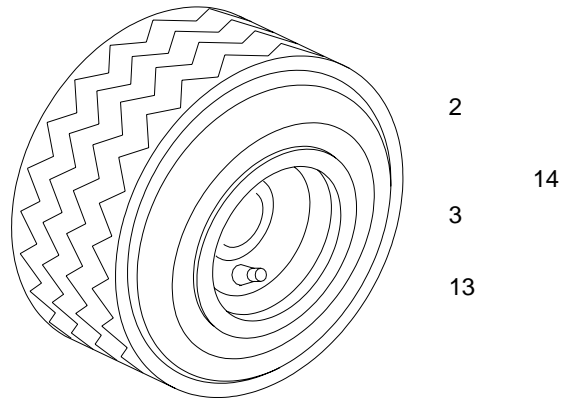

REF. NO.	PART NO.	QTY	DESCRIPTION
1	50019879	1	Axle 10"
2	50022630	1	Tire, 18 x 8.5 x 8 (Ribbed) TVM-5130
	50022625	1	Tire, 18 x 8.5 x 8 (Highway) TVM-5130
	50022628	1	Tire, 16 x 6.5 x 8 (Ribbed) TVM-3077
3	50022626	1	Wheel 8 x 7-5 Bolt, TVM-5130
	50022629	1	Wheel 8 x 5-3/8", 5 Bolt, TVM-3077
4	50022632	1	Seal
5	52012	5	Wheel Stud 1/2"-20 x 1-7/8"
6	50022631	1	Hub w/ Cups
7	170	2	Bearing Cup L44610
8	22	2	Bearing Cone L44643
9	120	1	Castle Nut 3/4"-16
10	50019662	1	Keyed Washer 3/4"
11	20166	1	Cotter Pin 1/8" x 1-1/4"
12	50022633	1	Dust Cap
13	50022627	1	Valve Stem
14	50022178	1	Ribbed Tire & Wheel Assy. TVM-5130
	50019920	1	Highway Tire & Wheel Assy. TVM-5130
	50022364	1	Highway Tire & Wheel Assy. TVM-3077
15	15515	5	Lug Nut, 1/2"-20 UNF
16	50022095	1	Hub Assy.

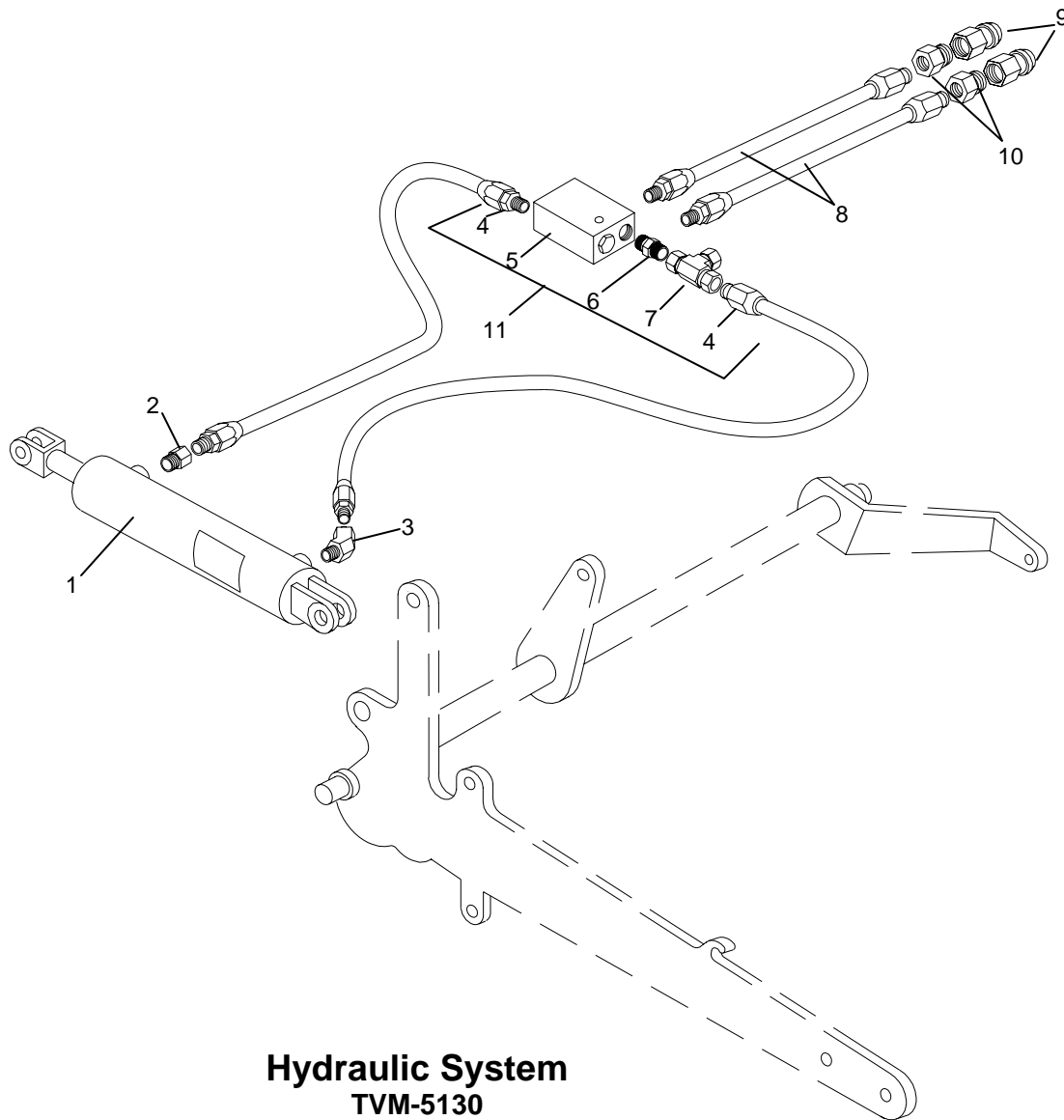

Hydraulic System TVM-5130

REF. NO.	PART NO.	QTY	DESCRIPTION
1	50022177	1	Hydraulic Cylinder 2-1/2" Bore x 10" Stroke x 1" Rod Dia. W/ Decal
	50022590	1	Seal repair Kit for 50022177 Hydraulic Cylinder
2	50022093	1	AD 1/4" NPTF x 1/4" NPTM -1/32" ORFC
3	50022094	1	Elbow 45° 1/4" NPTF x 1/4" NPTM
4	50019926	2	Hose Assembly 18" 1/4" NPTM ends
5	50019925	1	Check Valve
6	50019927	1	AD 1/4" NPTM Close Nipple
7	50019928	1	TE 1/4" NPTF Adaptor Tee
8	50022091	2	Hose Assembly 120"
9	50022092	2	QD Adaptor
10	50022090	2	AD 1/2" NPTM x 1/4" NPTF
11	50019929	1	Check Valve Assy.
12	50022079	1	Caution Decal

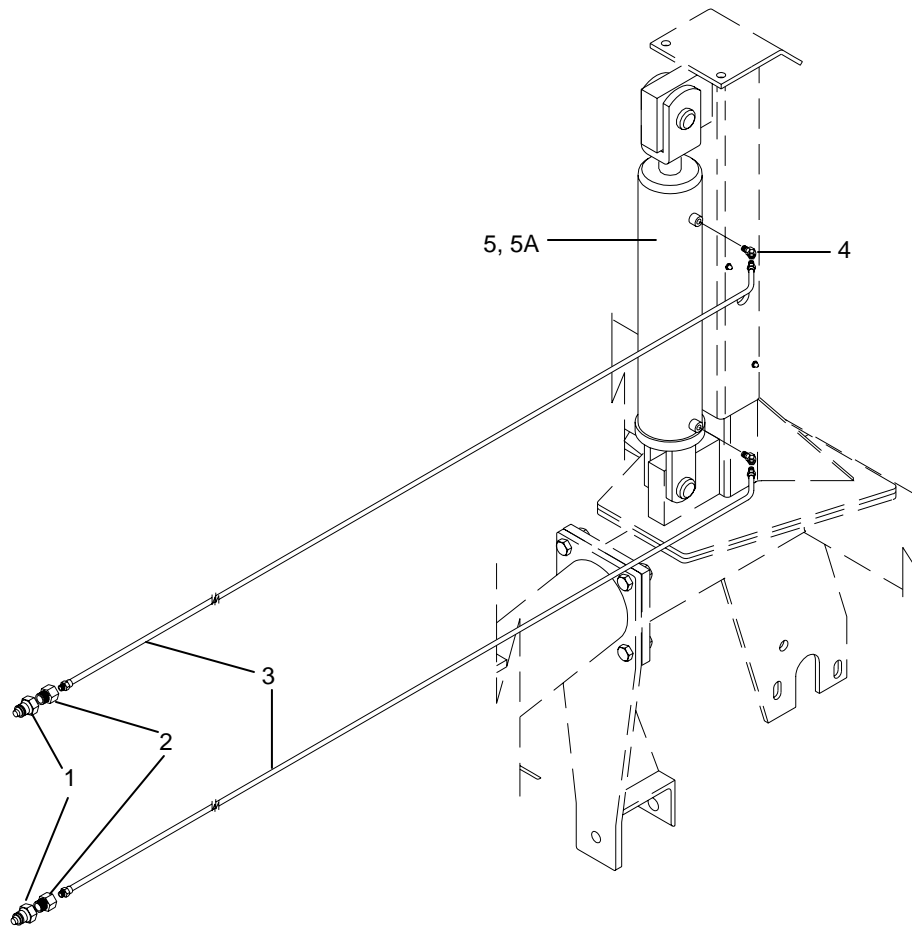

Hydraulics for Lift Bundle TVM-3077

REF. NO.	PART NO.	QTY	DESCRIPTION
1	50022092	2	Coupler 1/2" NPT
2	50022090	2	Adaptor 1/4" FNPT to 1/2" MNPT
3	50022091	2	Hose 1/4" FNPT to 1/2" MNPT
4	50022094	2	Elbow 45° 1/4" MNPT to 1/4" FNPT
5	50022089	2	Hydraulic Cylinder 2.5" Bore x 10" Stroke x 1-1/2" Rod Dia.
5A	50022590	1	Seal Kit for 50022089 Hydraulic Cyl.

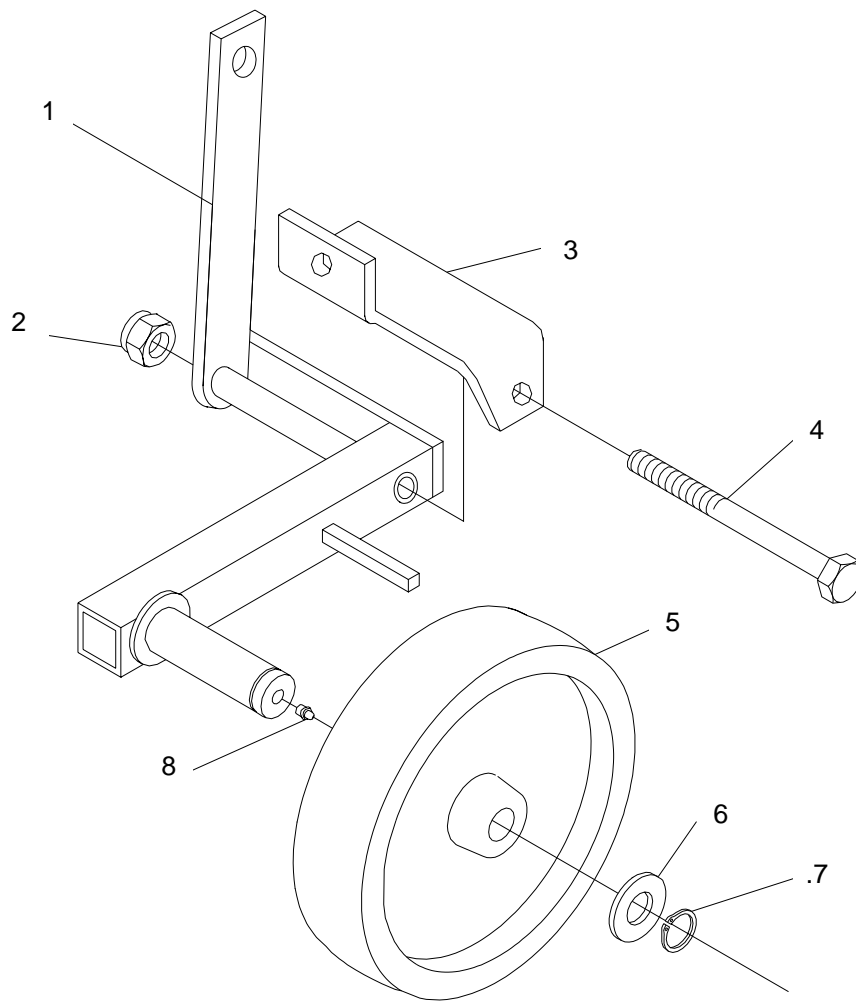

Adjusting Wheel TVM-3077 and TVM-5130

REF. NO.	PART NO.	QTY	DESCRIPTION
1	50038250	1	Wheel Pivot Arm Weldment Left Hand
	50037669	1	Wheel Pivot Arm Weldment Right Hand
2	44539	1	Hex Nut 1/2" CP Nylock
3	50037665	1	Wheel Brace Left Hand
	50037664	1	Wheel Brace Right Hand
4	20496	1	HHCS 1/2" x 5-1/2" G5 ZP
5	50022365	1	Wheel 8" x 2" x .75" Bore
6	50022409	1	Wheel Washer
7	50022408	1	Snap Ring External
8	449	1	Grease Fitting

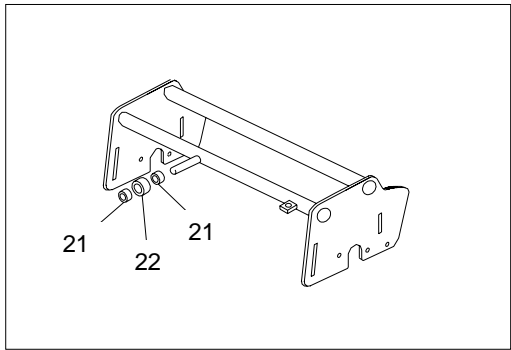
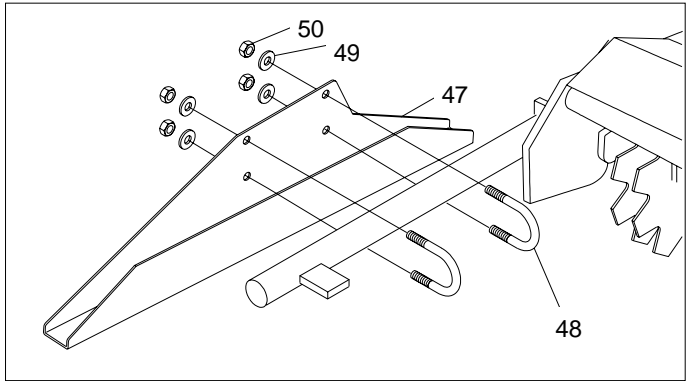
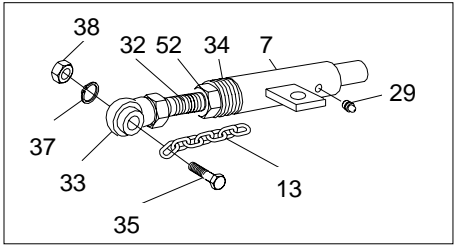
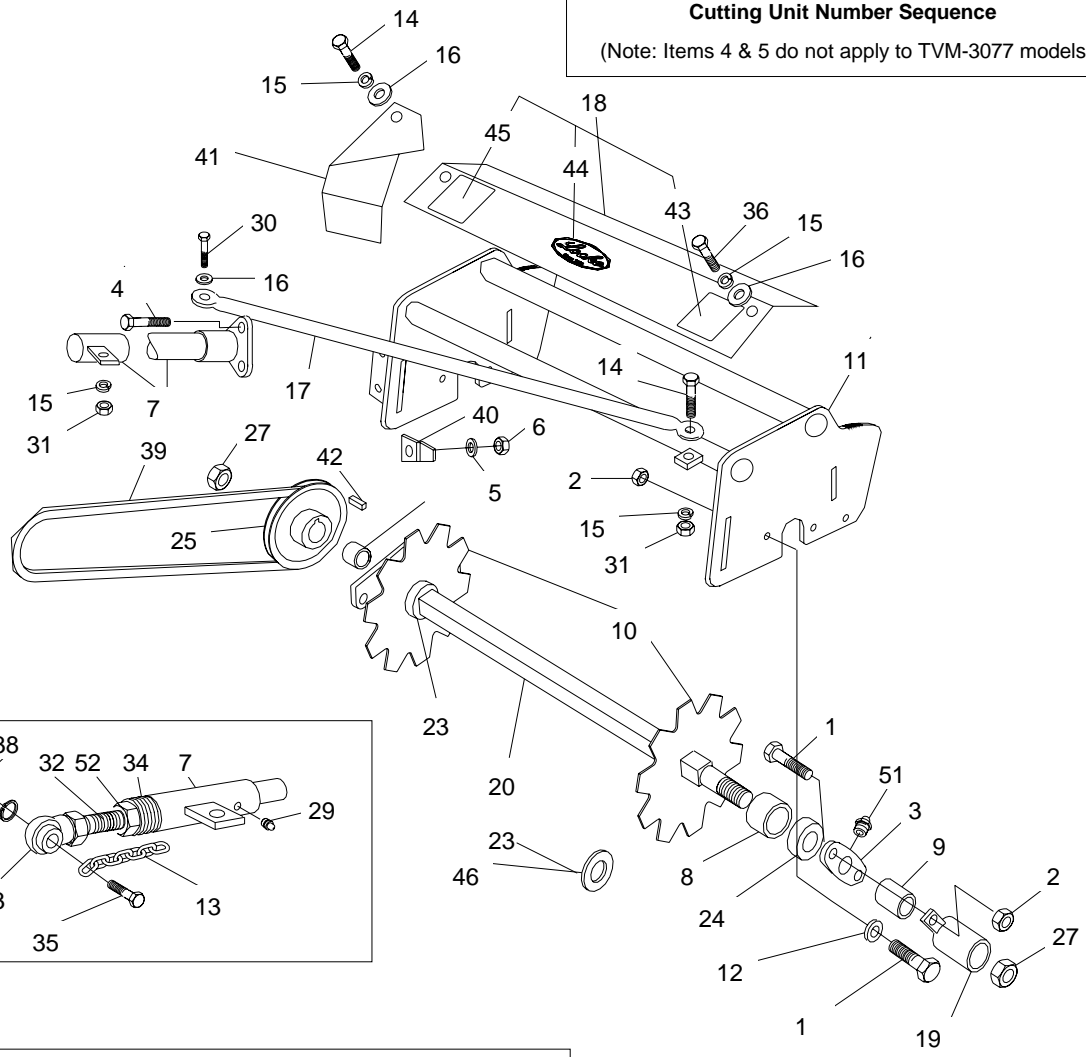
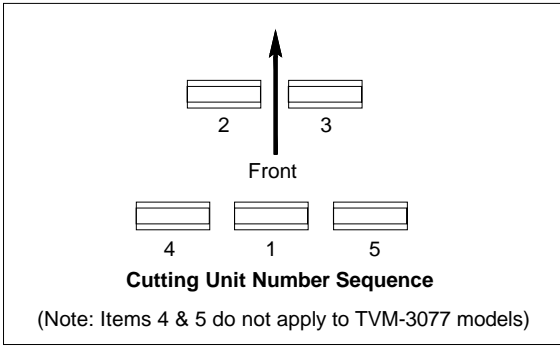

**Cutter Head
TVM-3077 & TVM-5130
(with standard .063" thick blades)**

REF. NO.	PART NO.	QTY	DESCRIPTION	REF. NO.	PART NO.	QTY	DESCRIPTION
1	44610	6	HHCS 7/16"-14 x 1" G8	26	50022106	1	Split Bushing, Taper SDS 1"
2	44617	6	Hex Nut, Nylock 7/16"-14	27	15614	2	Jam Nut 1"-14 UNF
3	50022380	2	Bearing 1" Bore, 2 Bolt Flange	28	50022374	1	Side Spacer (Drive Side)
4	44614	3	HHCS 7/16"-14 x 1-1/4" G8	29	449	1	Grease Fitting
5	15819	3	Lockwasher 7/16"	30	20011	1	HHCS 5/16"-18 x 1-1/2"
6	8151400	3	Hex Nut 7/16"-14 G5	31	15528	1	Hex Nut 5/16"-18
7	50037653	1	Telescoping Arm, Single Roller	32	50022363	1	Telescoping Arm Shaft
8	50022377	2	Outer Spacer	33	50022397	1	Ball Socket Weldment
9	50022375	1	Idler Side Spacer	34	50035243	1	Spring
10	50030203	22	Blade .063" Thick	35	50022123	1	Pivot Bolt w/ Shield Mount Hole
	110029	21	Dynablade w/Carbide tip (not shown)	36	1161006	1	HHCS 5/16"-18 x 3/4" G5
				37	146	1	Lockwasher 3/4"
11	50038260	1	No. 1, 2 & 3 Frame Weld.	38	19517	1	Hex Nut 3/4"-10
	50038261	1	No. 4 Frame Weld.	39	50022398	1	V-Belt BX68
	50038283	1	No. 5 Frame Weld.	40	50022395	1	Pulley Scraper RH
12	44618	A/R	Flatwasher 7/16" SAE G8		50022396	1	Pulley Scraper LH
13	50022142	1	Safety Chain	41	50038259	1	Pulley Guard LH
14	1161010	1	HHCS 5/16"-18 x 1"		50038258	1	Pulley Guard RH
15	15808	2	Lockwasher 5/16"	42	93810	1	Key 1" x 1/4"
16	20568	2	Flatwasher 5/16"	43	50022077	1	Danger Decal
17	50022199	1	Telescoping Arm Stay Rod	44	500033	1	Locke Turf Decal
18	50022325	1	#1, Shield Assy. w/ Decals	45	50022075	1	Danger Decal
	50022284	2	#2 & #3 Shield Assy. w/ Decals	46	50022378	A/R	Blade Spacer.125" Thick
	50022285	1	#4, Shield Assy. w/ Decals	47	50022459	1	Spring Guard
	50022286	1	#5, Shield Assy. w/ Decals	48	50022817	2	U-bolt 5/16" x 1-3/8" x 2-3/16"
19	50022394	1	Shaft Shield	49	20568	4	Flatwasher 5/16" SAE
20	50037663	1	Blade Shaft	50	44553	4	Hex Locknut 5/16" Nylock
21	50022212	1	Nylon Roller	51	50022184	2	Grease Fitting
22	50022213	2	Set Collar 1"	52	50035242	1	Jam Nut Nylon 1"-8
23	50022376	21	Blade Spacer, 22 Blade				
	50033874	33	Blade Spacer, 34 Blade				
	50033895	46	Blade Spacer, 46 Blade				
	50033894	82	Blade Spacer, 83 Blade				
24	50022381	2	Shaft Washer				
25	50022088	1	Pulley, 6.6" P.D.				

**50022425 Decal Kit
TVM-5130**

PART NO.	QTY	DESCRIPTION
50022064	1	Caution Decal (540 RPM, Gearbox)
50022065	1	Danger Decal (PTO Shield)
50022066	2	Danger Decal (Tongue)
50022067	2	Decal, Flag (Tongue)
50022070	1	Warning Decal (Tongue)
50022071	1	Warning Decal (Tongue)
50022072	1	Danger Decal (PTO Shield)
50022074	1	Notice Decal (PTO Shield)
50022075	10	Danger Decal (Reel Head Shield)
50022076	4	Caution Decal (Frame & Tire)
50022077	10	Danger Decal (Reel Head Shield)
50022079	1	Caution Decal (Cylinder)
50022081	1	Notice Decal (Tongue)
50022303	4	Caution Decal (Frame & Tire)
32767	4	Red Reflector
32768	4	Amber Reflector
50100034	1	Model Decal (TVM-5130)
500033	1	Locke Decal

**50022436 Decal Kit
TVM-3077**

PART NO.	QTY	DESCRIPTION
50022064	1	Caution Decal (540 RPM, Gearbox)
50022065	1	Danger Decal (PTO Shield)
50022066	2	Danger Decal (Tongue)
50022067	2	Decal, Flag (Tongue)
50022070	1	Warning Decal (Tongue)
50022071	1	Warning Decal (Tongue)
50022072	1	Danger Decal (PTO Shield)
50022074	1	Notice Decal (PTO Shield)
50022075	10	Danger Decal (Reel Head Shield)
50022076	4	Caution Decal (Frame & Tire)
50022077	10	Danger Decal (Reel Head Shield)
50022079	1	Caution Decal (Cylinder)
50022081	1	Notice Decal (Tongue)
50022303	4	Caution Decal (Frame & Tire)
32767	4	Red Reflector
32768	4	Amber Reflector
50100033	1	Model Decal (TVM-3077)
500033	1	Locke Decal



500033



50100033



50100034



50022064

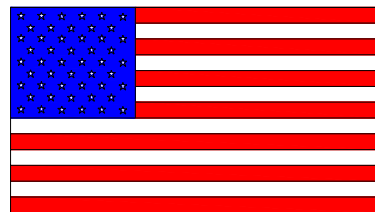

50022067



50022065



50022066



50022075



50022070



50022081

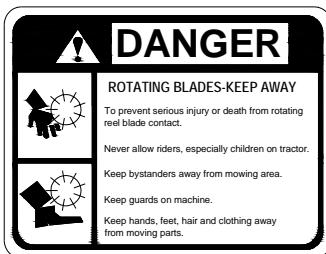

50022077

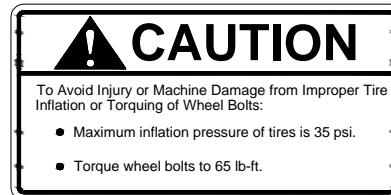

50022303

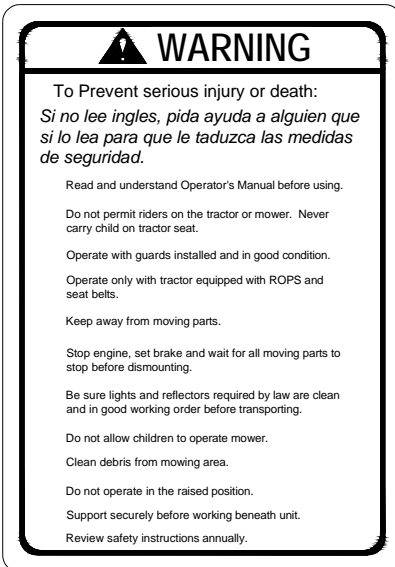

50022073



50022071

50022076

Red Reflector 53310



50022074

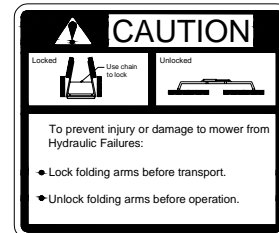

50022079



50022072

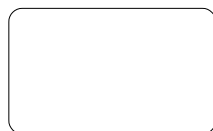

Amber Reflector 53315



Red Reflector 53316

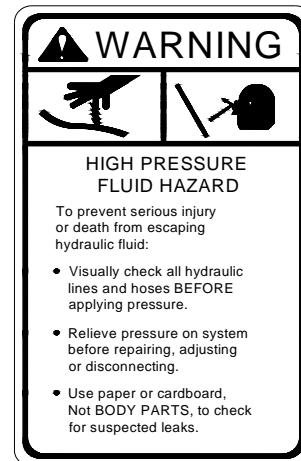

50022071

Notes

Notes



Locke Turf

307 Highway 52E, Opp, Alabama 36467, (334) 493-1300

Free Manuals Download Website

<http://myh66.com>

<http://usermanuals.us>

<http://www.somanuals.com>

<http://www.4manuals.cc>

<http://www.manual-lib.com>

<http://www.404manual.com>

<http://www.luxmanual.com>

<http://aubethermostatmanual.com>

Golf course search by state

<http://golfingnear.com>

Email search by domain

<http://emailbydomain.com>

Auto manuals search

<http://auto.somanuals.com>

TV manuals search

<http://tv.somanuals.com>