

LOWRANCE

SIRIUS 
SATELLITE RADIO



LWX-1



Satellite Weather Radio Module Installation Instructions

988-0158-13A

Copyright © 2009 Navico
All rights reserved.

No part of this manual may be copied, reproduced, republished, transmitted or distributed for any purpose, without prior written consent of Lowrance Electronics.

Lowrance® is a registered trademark of Navico.

Navico may find it necessary to change or end our policies, regulations and special offers at any time. We reserve the right to do so without notice. All features and specifications subject to change without notice.

For downloadable owner's manuals and the most current information on this product and its operation and accessories, visit our web site:

www.lowrance.com

Navico, Inc.
12000 E. Skelly Dr.
Tulsa, OK USA 74128-2486

This document covers the installation and status/diagnostic indicators available for the Lowrance LWX-1. It also details how to activate a SIRIUS subscription.



LWX-1 package include:

Main Components:

1. Antenna Receiver (AR) pre-configured for a mast mount
 - AR Interconnect Cable (attached to AR) connects to IM
2. Interface Module (IM)
 - IM Power Cable (attached to IM) connects to Vessel power
 - IM Network Cable (attached to IM) connects to ChartPlotter

Mounting Components:

1. AR Gasket (1)
2. AR Mounting Screws (4)
3. IM Mounting Screws (2)
4. AR Screw Caps (5; one extra)

Antenna Receiver (AR)



Interface Module (IM)

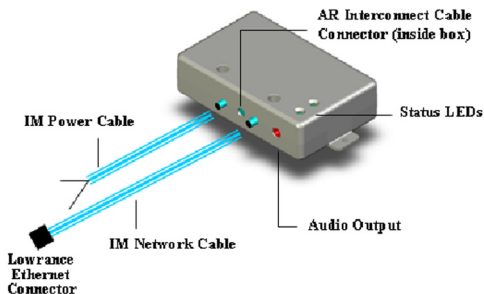

LWX-1 Installation Options

The LWX-1 can be mounted in three basic configurations:

1. AR Mast Mount (factory-installed option)
2. AR Flush Mount with cable routed through the mounting surface (e.g. deck)
3. AR Flush Mount with cable routed on top of the mounting surface

1. AR Mast Mount Installation

The LWX-1 AR is shipped in the retail box factory-configured for a mast mount.

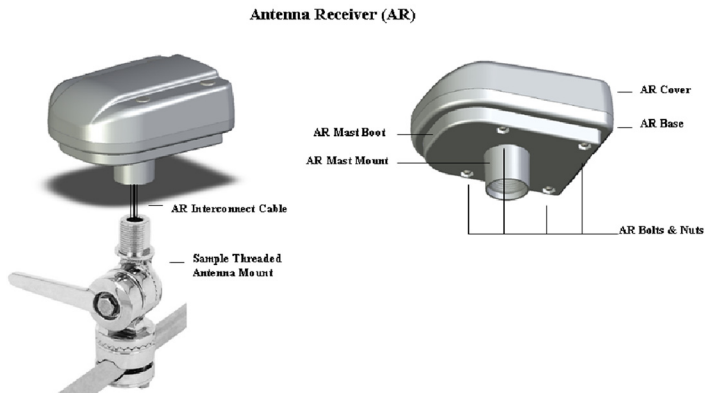

To use AR Mast Mount Installation:

1. Loosen the four AR Bolts & Nuts (a couple of counter-clockwise turns on each).
2. The AR Mast Boot will loosen, allowing the AR Mast Mount to turn.
3. Insert the AR Interconnect Cable into the Antenna Mount and route it carefully to the Interface Module (IM). Planning the cable route in advance will avoid multiple cable pulls that could increase the likelihood of damaging the connector.
4. Align the AR in the general position desired and screw the AR Mast Mount onto the Antenna Mount (hand-tighten as much as possible – DO NOT OVER-TIGHTEN). Note that the AR is a friction fit designed to allow for the occasional hand alignment.
5. With the AR Mast Mount installed, align the AR in position desired and re-tighten the four AR Bolt & Nuts.
6. Insert AR Screw Caps into AR Bolt recesses on the AR Cover.

2. AR Flush Mount Installation (through deck)

AR Flush Mount with cable routed through the deck.

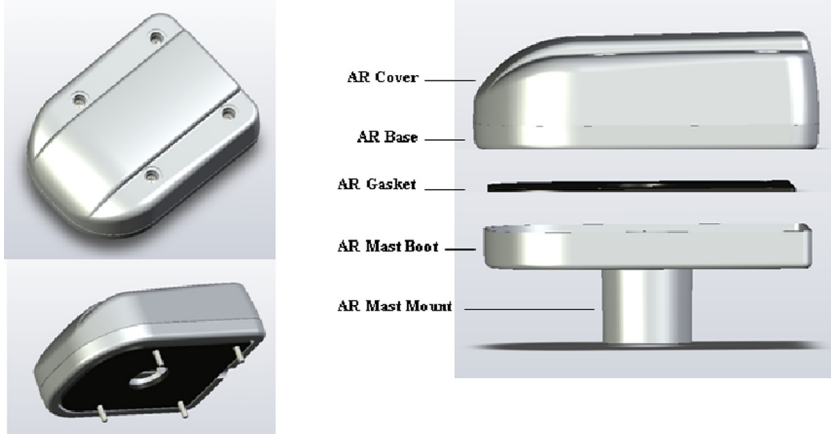

To use AR Flush Mount through-deck installation:

1. Remove the four AR Bolts & Nuts (the AR Cover and AR Base are factory fitted – DO NOT ATTEMPT TO SEPARATE THEM)
2. Use the AR Gasket as a template to mark where the AR Mounting Screws and AR Interconnect Cable holes are to be pre-drilled
3. Drill the 1/32 inch diameter starter holes for the AR Mounting Screws and the 1/2 inch diameter hole to route the AR Interconnect Cable through the deck. Make sure the gasket is sealed tightly against the deck
4. Insert AR Interconnect Cable through the deck and pull it through
5. Using the four AR Mounting Screws provided, mount the AR to the deck
6. Insert AR Screw Caps into AR Bolt recesses on the AR Cover

3. AR Flush Mount Installation (above deck)

In this AR Flush Mount installation, the cable is routed out the back of the LWX-1.

This installation is the same as AR Flush Mount through-deck Installation, except the AR Interconnect Cable is routed under the LWX-1 and out the back above the deck instead of through the deck.

To use AR Flush Mount above-deck installation:

1. With a pair of needle-nose pliers, break away and remove the AR Channel Stop
2. Insert the AR Interconnect Cable into cable channel on bottom of LWX-1
3. Ensure that the rubber boot on the AR Interconnect Cable is firmly in the AR Rubber Boot Inset so that it is flush with the bottom of the AR Base.
4. Gently form the AR Interconnect Cable from the exit of the rubber boot up and over the rear cable exit of the AR Base
5. Replace the AR Gasket on the AR Base, over the AR Interconnect Cable, and then install the AR as described in **“2. AR Flush Mount through deck installation.”**

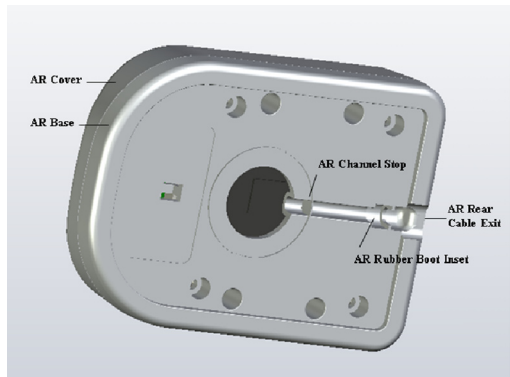

IM Installation

With all of the AR installation options, it is recommended that the IM is mounted/installed below deck.

To install the IM:

1. Open the IM enclosure by unscrewing the two IM Enclosure Screws on the front panel
2. Insert the male RJ45 connector on the end of the AR Interconnect Cable into the female RJ45 connector in the middle of the inside of the IM enclosure. The RJ45 connector will click into place when it is connected correctly
3. Route the AR Interconnect Cable through the exit slot of the IM enclosure (between the other two cables) and close the IM
4. Re-insert and tighten IM Enclosure Screws (from Step 1) on the IM cover
5. Mount the IM with the IM Mounting Screws provided, on a vertical surface, with the cables exiting downwards
6. Connect the IM Power Cable to the vessel's power (8 to 16 VDC source)
7. Connect the IM Network Cable to the Chartplotter

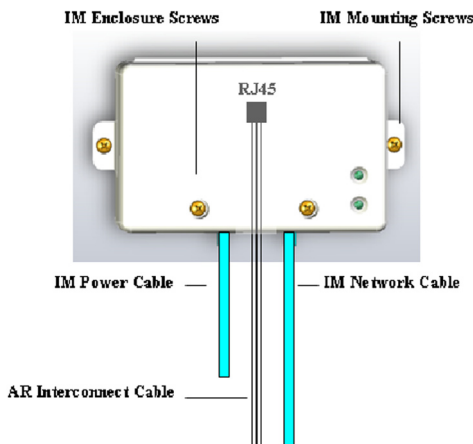

LWX-1 Status Indicators

The LWX-1 status indicators are the two LEDs on the Interface Module. The IM indicators are to be used to obtain connectivity with the end-user device, where more detailed problem diagnosis is available.

Power LED indicates LWX-1 Power:

1. LED OFF
 - No power to the Interface Module
2. LED ON (solid green)
 - Power to Interface Module

Status LED indicates LWX-1 Status:

1. LED OFF
 - Interface Module is not powered on
 - Antenna Receiver is disconnected
 - Antenna Receiver has malfunctioned and is inaccessible
2. LED ON (solid green)
 - Antenna Receiver is functioning correctly and providing SIRIUS Data and SIRIUS Audio (at least preview-level Audio and Data)
3. LED ON (blinks ON/OFF three times during the power-up cycle)
 - Antenna Receiver is functioning correctly; however, IM Network Cable is not connected to end-user device or end-user device is not operational.
4. LED ON (blinks ON/OFF three times during power-up cycle) then turns OFF
 - Antenna Receiver is not functioning correctly and IM Network Cable is not connected to end-user device

If LED blinks ON/OFF three times during the power-up cycle and then turns OFF, an Ethernet loop back connector should be connected to the IM Network Cable and the LWX-1 should be power cycled. If the blinking during power-up does not recur, then the IM Network Cable is good, and the end-user device should be checked.

When IM Network Cable is properly connected to the host device, the end-user can request a full LWX-1 Diagnostics Report to perform any further required diagnosis. The following section describes the information provided in this diagnostic report.

The SIRIUS satellite service activation process will require the SIRIUS ID for the SIRIUS Radio Module is visible to the user. This will allow the SIRIUS Listener Care call center to activate the user's subscription for the LWX-1. Signal Strength will also be important information for the user to verify that SIRIUS radio signal is available as this is required for successful activation.

LWX-1 SIRIUS Activation

You must have a SIRIUS subscription to use the LWX-1 module. Individual weather and audio subscriptions are available. You can also purchase a subscription that includes both weather and audio.

Before calling SIRIUS to activate a subscription for your LWX-1 make sure the following conditions are met:

- The LWX-1 and your display unit are turned on and connected via ethernet cable
- SIRIUS status info — antenna status and signal strength — is shown on your display unit screen (refer to your unit's operation manual to access the SIRIUS status screen)
- SIRIUS status screen shows signal strength of at least 1/3 with 2/3 or greater preferred
- Have the ESN — electronic serial number — for the LWX-1 readily available (ESN, a 12-digit number, can be found on the LWX-1 carton, LWX-1 antenna or via the SIRIUS status screen)
- Credit card/billing information is available

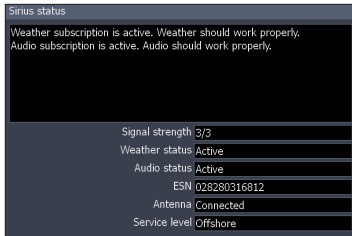

Signal strength, ESN and antenna status are shown on the SIRIUS status screen



Your ESN is also shown on the label attached to the LWX-1 carton

To activate a SIRIUS subscription:

1. After the LWX-1 module is installed, locate the label on the front flap of the LWX-1 carton
2. Record your ESN number (SIRIUS ID) and contact SIRIUS at 1-800-869-5480. SIRIUS Marine Weather service can only be activated by phone.



NOTE: *It may take several minutes for the activation signal to be received after subscription is activated.*

3. Access SIRIUS status screen to make sure subscription (Weather Status, Audio Status, or both) is listed as Active. If your account is inactive, contact information for SIRIUS will be displayed.
4. Check the SIRIUS signal level (1 is weak; 3 is excellent) and make sure your antenna is listed as “Connected.”

LWX-1 Diagnostic Report

The following information is shown in the Diagnostic Report retrievable by the Chartplotter. To view the Diagnostic report, access the SIRIUS Status screen and press **MENU**.

LWX-1 System Information		
Name	Description	Example
LWX-1 Software Version	Software version LWX-1 is running	LWX200807280148
LWX-1 Revision Level	Revision level of the LWX-1 hardware	LWX-NV-A
LWX-1 Electronic Serial Number	Serial number assigned to this LWX-1 during production	11090371
Data Activity	Indicates data is being received	1
Rx Count	Number of data messages received by the LWX-1	27871
Service Level	Activation level of the subscribed data service is shown. Values are assigned as follows: 0 – deactivated or unknown 1 – Inland Service Level 2 – Offshore Service Level	1
Position	The location of the receiver is shown. When the location is not known, the value will be reported as “Unknown”	37.352962- 73.536163

SIRIUS Module Information		
Name	Description	Example
Radio Activation Status - Data	<p>Indicates the activation status of the SIRIUS Radio Module. The first value indicating an active subscription.</p> <p>Parameter 1 — indicates is set to '1' when there are subscribed channels.</p> <p>Parameter 2 — provides a bit mask for the individualized, enabled and activated status indicators (counting up from bit 0). This is a hexadecimal value.</p> <p>Parameter 3 — indicates minutes left on a time limited activation. '-1' implies no timeout.</p>	<p>1 of -1</p> <p>This indicates a fully activated receiver.</p>
Radio Activation Status – Audio	Same as above	Same as above
Radio Active	Indicates SIRIUS Radio Module is active	1
Radio Antenna Status	Indicates the internal antenna is connected to the SIRIUS Radio Module.	1

Radio Signal Strength	Indicates the signal strength received by the SIRIUS Radio Module. The value is in the range of 0-3 with 3 being maximum. Values are defined as follows: 0 = no signal 1 = weak signal 2 = good signal 3 = excellent signal	2
Radio Channel – Data	Indicates the tuned data channel for the SIRIUS Radio Module	199
Radio SIRIUS ID	Indicates the SIRIUS ID for data of the SIRIUS Radio Module	005102294176
Radio Channel - Audio	Indicates the tuned audio channel for the SIRIUS Radio Module	14

NAVICO LIMITED TWO-YEAR LOWRANCE WARRANTY

“We,” “our,” or “us” refers to NAVICO, the manufacturer of this Lowrance product. “You” or “your” refers to the first person who purchases this product as a consumer item for personal, family or household use.

We warranty this product against defects or malfunctions in materials and workmanship, and against failure to conform to this product’s written specifications, all for two (2) years from the date of original purchase by you.

WE MAKE NO OTHER EXPRESS WARRANTY OR REPRESENTATION OF ANY KIND WHATSOEVER CONCERNING THIS PRODUCT.

Your remedies under this warranty will be available so long as you can show in a reasonable manner that any defect or malfunction in materials or workmanship, or any non-conformity with the product’s written specifications, occurred within two years from the date of your original purchase, which must be substantiated by a dated sales receipt or sales slip.

Any such defect, malfunction, or non-conformity which occurs within two years from the original purchase date will either be repaired without charge or be replaced with a new product identical or reasonably equivalent to this product, at our option, within a reasonable time after our receipt of the product. If such defect, malfunction, or non-conformity remains after a reasonable number of attempts to repair by us, you may elect to obtain without charge a replacement of the product or a refund for the product.

THIS REPAIR, OR REPLACEMENT OR REFUND (AS JUST DESCRIBED) IS THE EXCLUSIVE REMEDY AVAILABLE TO YOU AGAINST US FOR ANY DEFECT, MALFUNCTION, OR NON-CONFORMITY CONCERNING THE PRODUCT OR FOR ANY LOSS OR DAMAGE RESULTING FROM ANY OTHER CAUSE WHATSOEVER. WE WILL NOT UNDER ANY CIRCUMSTANCES BE LIABLE TO ANYONE FOR ANY SPECIAL, CONSEQUENTIAL, INCIDENTAL, OR OTHER INDIRECT DAMAGE OF ANY KIND.

Some states do not allow the exclusion or limitation of incidental or consequential damages, so the above limitations or exclusions may not apply to you. This warranty does NOT apply in the following circumstances: (1) when the product has been serviced or repaired by anyone other than us; (2) when the product has been connected, installed, combined, altered, adjusted, or handled in a manner other than according to the instructions furnished with the product; (3) when any serial number has been effaced, altered, or removed; or (4) when any defect, problem, loss, or damage has resulted from any accident, misuse, negligence, or carelessness, or from any failure to provide reasonable and necessary maintenance in accordance with the instructions of the owner’s manual for the product.

We reserve the right to make changes or improvements in our products from time to time without incurring the obligation to install such improvements or changes on equipment or items previously manufactured.

This warranty gives you specific legal rights and you may also have other rights which may vary from state to state. You must retain the sales slip or sales receipt proving the date of your original purchase in case warranty service is ever required.

NAVICO
12000 E. SKELLY DRIVE, TULSA, OK 74128
WWW.LOWRANCE.COM

LOWRANCE®

www.lowrance.com

988-0158-13A

Pub. 012809

© Copyright 2009
All Rights Reserved
Navico

Free Manuals Download Website

<http://myh66.com>

<http://usermanuals.us>

<http://www.somanuals.com>

<http://www.4manuals.cc>

<http://www.manual-lib.com>

<http://www.404manual.com>

<http://www.luxmanual.com>

<http://aubethermostatmanual.com>

Golf course search by state

<http://golfingnear.com>

Email search by domain

<http://emailbydomain.com>

Auto manuals search

<http://auto.somanuals.com>

TV manuals search

<http://tv.somanuals.com>