

**INSTALLATION AND OPERATION
INSTRUCTIONS**

MODEL

LDT-3001

**DIGITAL SURFACE TEMPERATURE
METER**



LOWRANCE ELECTRONICS, INC.
12000 E. SKELLY DR., TULSA, OK 74128

The LDT-3001 is a digital temperature meter. It's operation is completely automatic. There are no controls. This unit fits in a standard 2 1/8" (54 mm) hole used by most marine equipment manufacturers.

Mounting

This unit needs at least 2 1/2" (64 mm) of space to mount on any flat panel or dash. To install the unit, also make certain there is at least 3 3/4" (95 mm) from the *front* of the dash to any obstruction behind the dash. Check to be sure there is room to route the power and sensor cables. The *maximum* usable dash thickness is 1 1/8" (28.5 mm).

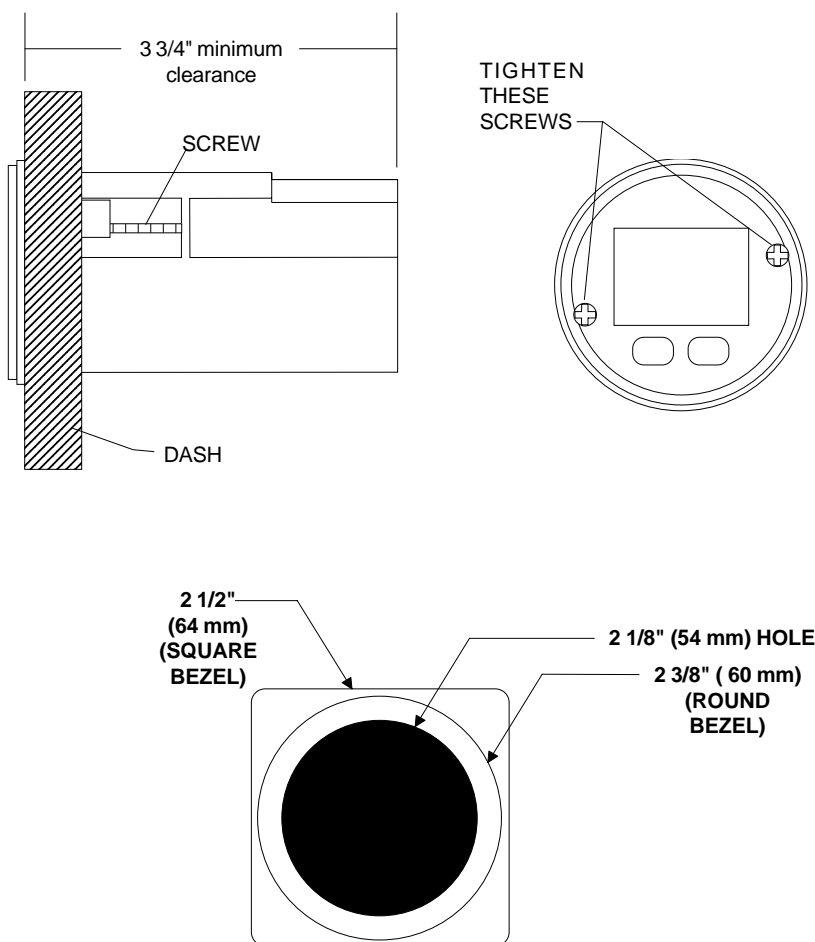

When you determine the location for the unit, drill a 2 1/8" (54 mm) hole in the dash. Slide the unit through the hole from the front of the dash. Align it so that it's straight, then tighten the two screws with a phillips-head screwdriver.

CAUTION!

To prevent damage to the unit, **DO NOT** use a pneumatic/power screwdriver. Use a hand-held screwdriver and the torque should not exceed 7 in lbs. Also, when removing the unit, do not back the screws out of the case. Damage to the faceplate will result. We recommend backing off the screws one complete turn before attempting to remove the unit. If further loosening of the screws is required, do so in half-rotation increments.

Place the bezel on the front of the unit and snap the bezel over the faceplate. The unit is now ready for wiring.

POWER CONNECTIONS (see diagram on the next page)

The 3001 operates from 10-15 VDC (12 volt battery). The power cable has three wires - red, black, and white. The red wire is the positive conductor. Connect it to an accessory switch.

IMPORTANT!

Make certain the red wire is fused. If the boat manufacturer installed your unit, check the wiring and locate the 3001's fuse holder. It should have a 1 amp fuse installed. If you purchased the 3001 from a dealer, a fuse holder with fuse is supplied. Follow the wiring diagram carefully.

The unit won't be harmed if the power wires are connected backwards, however it won't work until the wires are properly attached.

The black wire in the power cable is the negative or ground conductor. Connect it directly to the battery's negative terminal or the boat's ground buss.

The white wire is attached to the display's backlight. You can attach this wire to the power switch, a separate switch, or the boat's main lighting switch.

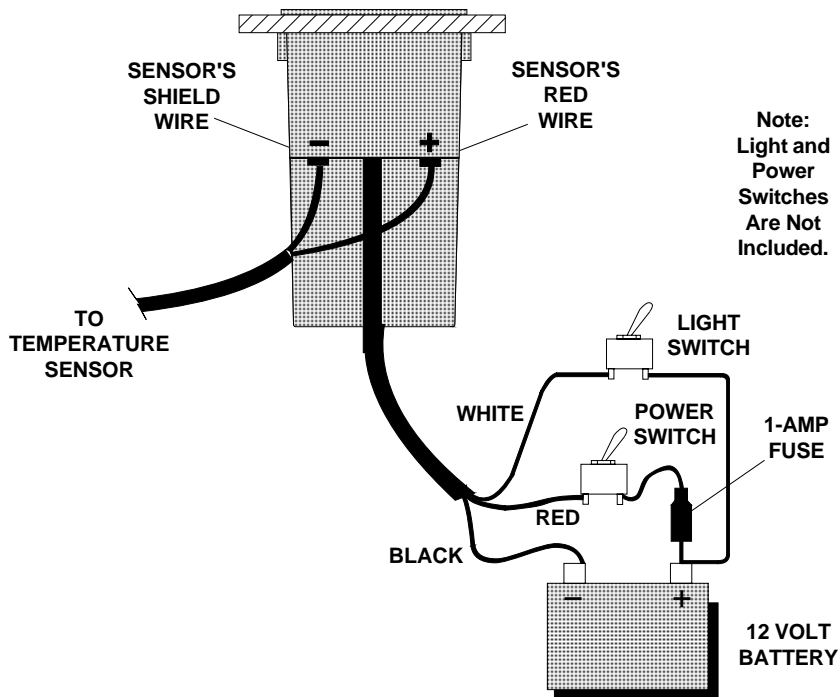

SENSOR CONNECTIONS

Mount the temperature sensor in a location that allows contact with the water at all times. The illustration below shows a typical location. Once a suitable place is found, mount the sensor to the hull with two #8 stainless steel screws. (not included) Route the sensor cable to the 3001. Do not cut the cable if it is too long! Coil and store it out of the way.

Attach the sensor wires to the 3001 using the supplied screws and washers. Make certain to attach the sensor's wires to the 3001 according to the diagram shown below. If the wires are reversed, no damage to the unit will occur, but it won't work properly. The 3001 is now ready for use.

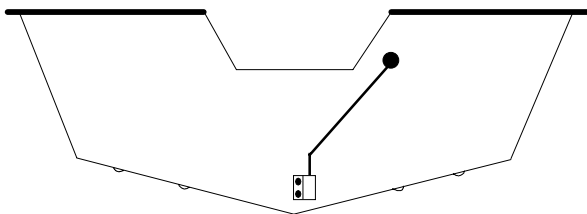

OPERATION

To use the 3001, simply turn the power switch on. The 3001 will instantly show the surface water temperature. This unit shows temperature in degrees Fahrenheit, in tenths of a degree. If the temperature is above 99.9 degrees, a small arrow appears in the upper left corner of the display appears. For example, if the display reads 01.4 and the arrow is also on, then the water temperature is 101.4 degrees.



TEMPERATURE = 75.6 DEGREES FAHRENHEIT



TEMPERATURE = 102.4 DEGREES FAHRENHEIT

LOWRANCE ELECTRONICS FULL ONE-YEAR WARRANTY

"We", "our", or "us" refers to LOWRANCE ELECTRONICS, INC., the manufacturer of this product. "You" or "your" refers to the first person who purchases this product as a consumer item for personal, family, or household use.

We warrant this product against defects or malfunctions in materials and workmanship, and against failure to conform to this product's written specifications, all for one year (1) from the date of original purchase by you. **WE MAKE NO OTHER EXPRESS WARRANTY OR REPRESENTATION OF ANY KIND WHATSOEVER CONCERNING THIS PRODUCT.** Your remedies under this warranty will be available so long as you can show in a reasonable manner that any defect or malfunction in materials or workmanship, or any non-conformity with the product's written specifications, occurred within one year from the date of your original purchase, which must be substantiated by a dated sales receipt or sales slip. Any such defect, malfunction, or non-conformity which occurs within one year from your original purchase date will either be repaired without charge or be replaced with a new product identical or reasonably equivalent to this product, at our option, within a reasonable time after our receipt of the product. If such defect, malfunction, or non-conformity remains after a reasonable number of attempts to repair by us, you may elect to obtain without charge a replacement of the product or a refund for the product. **THIS REPAIR, REPLACEMENT, OR REFUND (AS JUST DESCRIBED) IS THE EXCLUSIVE REMEDY AVAILABLE TO YOU AGAINST US FOR ANY DEFECT, MALFUNCTION, OR NON-CONFORMITY CONCERNING THE PRODUCT OR FOR ANY LOSS OR DAMAGE RESULTING FROM ANY OTHER CAUSE WHATSOEVER.** WE WILL NOT UNDER ANY CIRCUMSTANCES BE LIABLE TO ANYONE FOR ANY SPECIAL, CONSEQUENTIAL, INCIDENTAL, OR OTHER INDIRECT DAMAGE OF ANY KIND.

Some states do not allow the exclusion or limitation of incidental or consequential damages, so the above limitations or exclusions may not apply to you.

This warranty does NOT apply in the following circumstances: (1) when the product has been serviced or repaired by anyone other than us, (2) when the product has been connected, installed, combined, altered, adjusted, or handled in a manner other than according to the instructions furnished with the product, (3) when any serial number has been effaced, altered, or removed, or (4) when any defect, problem, loss, or damage has resulted from any accident, misuse, negligence, or carelessness, or from any failure to provide reasonable and necessary maintenance in accordance with the instructions of the owner's manual for the product.

We reserve the right to make changes or improvements in our products from time to time without incurring the obligation to install such improvements or changes on equipment or items previously manufactured.

This warranty gives you specific legal rights and you may also have other rights which may vary from state to state.

REMINDER: You must retain the sales slip or sales receipt proving the date of your original purchase in case warranty service is ever required.

How to Obtain Service (Canadian Customers Only)

We back your investment in quality products with quick, expert service and genuine Eagle replacement parts. If you need service or repairs, contact the Lowrance Factory Customer Service Department at the toll-free number listed below. A technician may be able to solve the problem and save you the inconvenience of returning your unit. You will be asked for your unit's serial number.

800-324-1356

Canada Only. Monday through Friday 8:00 A.M. - 8:00 P.M. Central Time.

How to Obtain Service (International Customers Only)

If you need service or repairs, contact the dealer in the country you purchased your unit.

**WARRANTY REPAIR WILL BE HONORED ONLY IN THE COUNTRY
UNIT WAS PURCHASED.**

Please follow the shipping instructions shown below on this page if you have to mail your unit to the dealer. For proper testing, repair, and service, send a brief note with the product describing the problem. Be sure to include your name, return shipping address, and a daytime telephone number.

Shipping Information

When sending a product for repair, we recommend you do the following:

1. Always use the original shipping container and filler material the product was packed in when shipping your product.
2. Always insure the parcel against damage or loss during shipment. Eagle does not assume responsibility for goods lost or damaged in transit.
3. For proper testing, repair, and service, send a brief note with the product describing the problem. Be sure to include your name, return shipping address, and a daytime telephone number.

Accessory Ordering Information

To order accessories such as power cables or transducers, please contact:

1. Your local marine dealer. Most quality dealers that handle marine electronic equipment should be able to assist you with these items. Consult your local telephone directory for listings.
2. Canadian customers only can write:
Lowrance/Eagle Canada, 919 Matheson Blvd., E. Mississauga, Ontario L4W2R7
or fax 416-629-3118

How to Obtain Service (U.S.A. Only)

We back your investment in quality products with quick, expert service and genuine Lowrance® replacement parts. If you're in the United States and you have questions, please contact the Factory Customer Service Department using our toll-free number listed below. You must send the unit to the factory for warranty service or repair. Please call the factory before sending the unit. You will be asked for your unit's serial number. Use the following toll-free number:

800-324-1356

Your unit is covered by a full one-year warranty. (See inside for complete warranty details.) If your unit fails and the failure is not covered by the original warranty, Lowrance has a flat-rate repair policy that covers your unit and accessories packed with the unit at the factory. There is a 180-day warranty on all non-warranty repairs from the factory, which is similar to the original warranty, but is for 180 days rather than one year. For further details, please call us at the above number.

Lowrance Electronics may find it necessary to change or end our shipping policies, regulations, and special offers at any time. We reserve the right to do so without notice.

Accessory Ordering Information

To order accessories such as power cables or transducers, please contact:

- 1) Your local marine dealer. Most quality dealers that handle marine electronic equipment should be able to assist you with these items. Consult your local telephone directory for listings.
- 2) LEI Extras, Inc. P.O. Box 129 Catoosa, OK 74015-0129
or call
800-324-0045
(USA orders only.)

LOWRANCE ELECTRONICS, INC. 12000 E SKELLY DR TULSA OK 74128

Free Manuals Download Website

<http://myh66.com>

<http://usermanuals.us>

<http://www.somanuals.com>

<http://www.4manuals.cc>

<http://www.manual-lib.com>

<http://www.404manual.com>

<http://www.luxmanual.com>

<http://aubethermostatmanual.com>

Golf course search by state

<http://golfingnear.com>

Email search by domain

<http://emailbydomain.com>

Auto manuals search

<http://auto.somanuals.com>

TV manuals search

<http://tv.somanuals.com>