

SA1232 3-WAY ACTIVE SPEAKER SYSTEM USER'S MANUAL

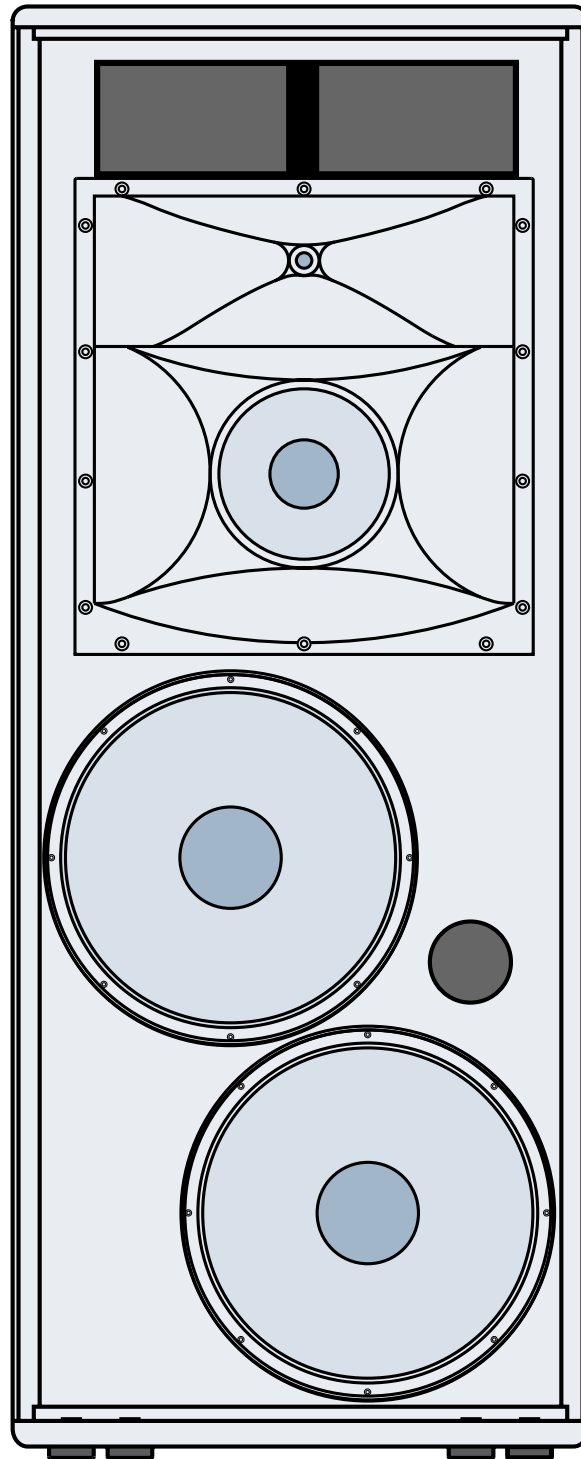

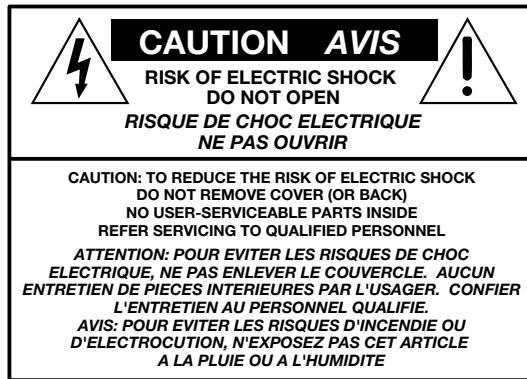

The lightning flash with arrowhead symbol within an equilateral triangle is intended to alert the user to the presence of uninsulated "dangerous voltage" within the product's enclosure that may be of sufficient magnitude to constitute a risk of electric shock to persons.

Le symbole éclair avec point de flèche à l'intérieur d'un triangle équilatéral est utilisé pour alerter l'utilisateur de la présence à l'intérieur du coffret de "voltage dangereux" non isolé d'ampleur suffisante pour constituer un risque d'électrocution.



The exclamation point within an equilateral triangle is intended to alert the user of the presence of important operating and maintenance (servicing) instructions in the literature accompanying the appliance.

Le point d'exclamation à l'intérieur d'un triangle équilatéral est employé pour alerter les utilisateurs de la présence d'instructions importantes pour le fonctionnement et l'entretien (service) dans le livret d'instruction accompagnant l'appareil.

SAFETY INSTRUCTIONS

1. Read Instructions — All the safety and operation instructions should be read before this Mackie product is operated.
2. Retain Instructions — The safety and operating instructions should be kept for future reference.
3. Heed Warnings — All warnings on this Mackie product and in these operating instructions should be followed.
4. Follow Instructions — All operating and other instructions should be followed.
5. Water and Moisture — This Mackie product should not be used near water — for example, near a bathtub, washbowl, kitchen sink, laundry tub, in a wet basement, near a swimming pool, swamp, or salivating St. Bernard dog, etc.
6. Cleaning — Clean only with a dry cloth.
7. Ventilation — This Mackie product should be situated so that its location or position does not interfere with its proper ventilation. For example, the Component should not be situated on a bed, sofa, rug, or similar surface that may block any ventilation openings, or placed in a built-in installation such as a bookcase or cabinet that may impede the flow of air through ventilation openings.
8. Heat — This Mackie product should be situated away from heat sources such as radiators or other devices which produce heat.

WARNING: The heatsink may reach high temperatures during standard use. To ensure proper operation, allow a minimum of 6 inches of clearance from the heatsink surface and adequate ventilation.

9. Power Sources — This Mackie product should be connected to a power supply only of the type described in these operation instructions or as marked on this Mackie product.

10. Power Cord Protection — Power supply cords should be routed so that they are not likely to be walked upon or pinched by items placed upon or against them, paying particular attention to cords at plugs, convenience receptacles, and the point where they exit this Mackie product.

11. Object and Liquid Entry — Care should be taken so that objects do not fall into and liquids are not spilled into this Mackie product.

12. Damage Requiring Service — This Mackie product should be serviced only by qualified service personnel when:

- A. The power-supply cord or the plug has been damaged; or
- B. Objects have fallen, or liquid has spilled into this Mackie product; or
- C. This Mackie product has been exposed to rain; or
- D. This Mackie product does not appear to operate normally or exhibits a marked change in performance; or
- E. This Mackie product has been dropped, or its chassis damaged.

13. Servicing — The user should not attempt to service this Mackie product beyond those means described in this operating manual. All other servicing should be referred to the Mackie Service Department.

14. To prevent electric shock, do not use this polarized plug with an extension cord, receptacle, or other outlet unless the blades can be fully inserted to prevent blade exposure.

Pour prévenir les chocs électriques ne pas utiliser cette fiche polarisée avec un prolongateur, un prise de courant ou une autre sortie de courant, sauf si les lames peuvent être insérées à fond sans laisser aucune partie à découvert.

15. Grounding or Polarization — Precautions should be taken so that the grounding or polarization means of this Mackie product is not defeated.

16. Power Precaution — Unplug this Mackie product during lightning storms or when unused for long periods of time. Note that this Mackie product is not completely disconnected from the AC mains service when the power switch is in the OFF position.

17. This apparatus does not exceed the Class A/Class B (whichever is applicable) limits for radio noise emissions from digital apparatus as set out in the radio interference regulations of the Canadian Department of Communications.

ATTENTION — *Le présent appareil numérique n'émet pas de bruits radioélectriques dépassant les limites applicables aux appareils numériques de class A/de class B (selon le cas) prescrites dans le règlement sur le brouillage radioélectrique édicté par les ministere des communications du Canada.*

WARNING — To reduce the risk of fire or electric shock, do not expose this appliance to rain or moisture.

WARNING — The cabinet has no rigging points and is not suitable for flying. Never attempt to suspend the cabinet by its handles. The SA 1232 should never be pole-mounted.

Lend Me Your Ears



Exposure to extremely high noise levels may cause permanent hearing loss. Individuals vary considerably in susceptibility to noise-induced hearing loss, but nearly everyone will lose some hearing if exposed to sufficiently intense noise for a period of time. The U.S. Government's Occupational Safety and Health Administration (OSHA) has specified the permissible noise level exposures shown in this chart.

According to OSHA, any exposure in excess of these permissible limits could result in some hearing loss. To ensure against potentially dangerous exposure to high sound-pressure levels, it is recommended that all persons exposed to equipment capable of producing these levels use hearing protectors while this unit is in operation. Ear plugs or protectors in the ear canals or over the ears must be worn when operating this amplification system in order to prevent a permanent hearing loss if exposure is in excess of the limits set forth here.

Duration Per Day In Hours	Sound Level dBA, Slow Response	Typical Example
8	90	Duo in small club
6	92	
4	95	Subway Train
3	97	
2	100	Very loud classical music
1.5	102	
1	105	Patrice screaming at Ron about deadlines
0.5	110	
0.25 or less	115	Loudest parts at a rock concert



The SA1232 can produce a maximum SPL of 136 dB @ 1m

Contents

SAFETY INSTRUCTIONS	2
INTRODUCTION	4
REAR PANEL DESCRIPTION	5
HOOKUP DIAGRAM	5
CONNECTIONS	6
PLACEMENT	6
AC POWER	7
THERMAL CONSIDERATIONS	8
SERVICE INFORMATION	9
Warranty Service	9
Troubleshooting	9
Repair	10
CARE AND MAINTENANCE	10
SA1232 SPECIFICATIONS	11
Architects and Engineers' Specifications	12
Graphs	13
SA1232 LIMITED WARRANTY	15

Don't forget to visit our website at www.mackie.com for more information about this and other Mackie products.



INTRODUCTION

Thank you for choosing Mackie Designs' active sound reinforcement speaker systems.

The SA1232 is a high-efficiency, extreme output, active 3-way, wide dispersion, sound reinforcement speaker system. The SA1232 benefits from the integration of 1300 watts of amplifier power, complete active control electronics, and RCF Precision components. These elements together form a speaker system with 103 dB of sensitivity (@ 1 watt/1 meter). The result is unprecedented output, resolution and clarity.

The SA1232 features the same horn assembly we introduced in the Mackie Designs SR1530 active 3-way speaker. The horn is a one piece design with 90° x 40° dispersion that integrates both the mid-range and high-frequency sections. This provides seamless coupling between the MF and HF sections. The 6-inch mid-range's basket assembly is designed as part of the horn assembly and is also designed to function as an optimized compression chamber, dramatically simplifying the mid-range assembly. The SA1232 features an "Optimized Wavefront" horn design. Unlike typical mid/high horns where the mid- and high-frequency horns are physically pointing to a different location in front of the box, the SA1232's high-frequency section is positioned to fire down into the six-inch mid-range's dispersion pattern. This creates a focused, single wave front with excellent phase and power response characteristics. With the resulting 90° x 40° dispersion pattern, the SA1232 provides very open, natural sound reproduction at extreme output levels.

The SA1232 Mid/High Section is designed to deliver over 136 dB of acoustic output. In order to achieve this, the SA1232 incorporates several state of the art advancements in transducer technology, which were developed over a two year period. The compression driver is a new 1.75-inch titanium diaphragm design. It features a 3-slot, low-distortion geometry phase plug.

The motor structure uses a high-grade neodymium magnet providing extraordinarily high BL (gauss) and performance. The magnetic structure for both the high-frequency and mid-frequency drivers

incorporate pure, high grade, neodymium providing a higher gauss capability, significant weight reduction, and higher BL (force) in the magnetic gap. This results in better control of the moving mass, and audio reproduction with lower distortion and excellent linearity.

The amplifiers for the compression driver and mid-range driver incorporate a Class AB topology renowned for its clarity and warmth, and for its ability to produce the high-

voltage output required to generate extreme SPL levels.

By using two 12-inch woofers, we provide a cone surface area larger than a single 18-inch device, yet we are able to move it by an order of magnitude faster. This results in an extremely tight, deep bottom end, while efficiently reaching the mid-frequency crossover point. The low-frequency amplifier features an innovative Class G hybrid topology, which features two power supplies for improved efficiency that delivers 1100 watts rms (continuous), and 1400 watts peak at 100 Hz.

The rear mounted amplifier assembly features separate signal and AC power panels separated by a large aluminum heatsink. The signal input panel contains:

- an input XLR and loop-through XLR
- a volume level control
- Power On indicator
- Signal Present indicator
- Limit indicator
- Thermal protection indicator

The system accepts a standard line-level signal via an XLR input connector.

The SA1232 cabinet is constructed using both multi-layered Baltic birch plywood and pressure-injected structural resin caps. The handles on each side are placed at the speaker's center of gravity for easy carrying and setup. The top and bottom sections both have handles for easy movement and relocation.

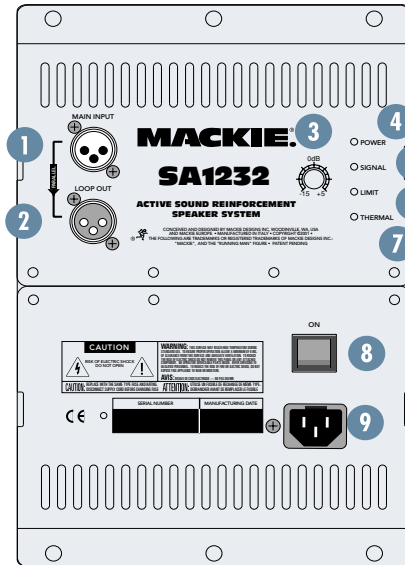

REAR PANEL DESCRIPTION 6 LIMIT Indicator

1 MAIN INPUT

This is a female XLR-type connector that accepts a balanced line-level signal from a mixing console or other signal source.

2 LOOP OUT

This is a male XLR-type connector that produces exactly the same signal that is connected to the MAIN INPUT jack. Use it to daisy-chain several SA1232s together off the same signal source.

3 Level Control

This controls the overall signal level at the input to the built-in power amplifiers. It ranges from -15 dB to $+5$ dB of gain. The center detent is 0 dB (unity gain).

4 Power ON Indicator

When the power switch is turned on, and the linecord is connected to an active AC power supply, this indicator lights green to let you know that you're ready to rock and roll. The cool blue LED on the front of the cabinet works in the same way.

5 SIGNAL Present Indicator

This LED illuminates whenever there is a signal present at the MAIN INPUT connector on the rear panel. It senses the signal just after the Level control, so if the Level control is turned down, the SIGNAL Present indicator turns off.

The SA1232 has a built-in limiter that prevents the amplifier outputs from clipping or overdriving the transducers. The LIMIT indicator lights when the limiter is activated. It's okay for the LIMIT indicator to blink occasionally, but if it blinks frequently or lights continuously, turn down the level control until the LIMIT indicator only blinks occasionally.

7 THERMAL Indicator

There is also a thermal protection circuit that monitors the internal temperature of the amplifiers and heatsink. If the temperature should exceed a safe operating level, this indicator lights and the signal is muted to allow the amplifiers to cool. When the temperature cools to a safe level once again, the thermal protection circuit deactivates and normal operation continues.

Note: Activation of the thermal protection circuit is an indication that you should take steps to avoid continued thermal problems. See "Thermal Considerations" on page 8.

8 Power Switch

Use this switch to turn the SA1232 on and off. Make sure the level control is turned down before you turn it on.

9 AC Receptacle

This is where you connect the AC linecord to provide AC power to the SA1232's built-in power amplifiers. Plug the linecord into an AC socket properly configured for your particular model.

HOOKUP DIAGRAM

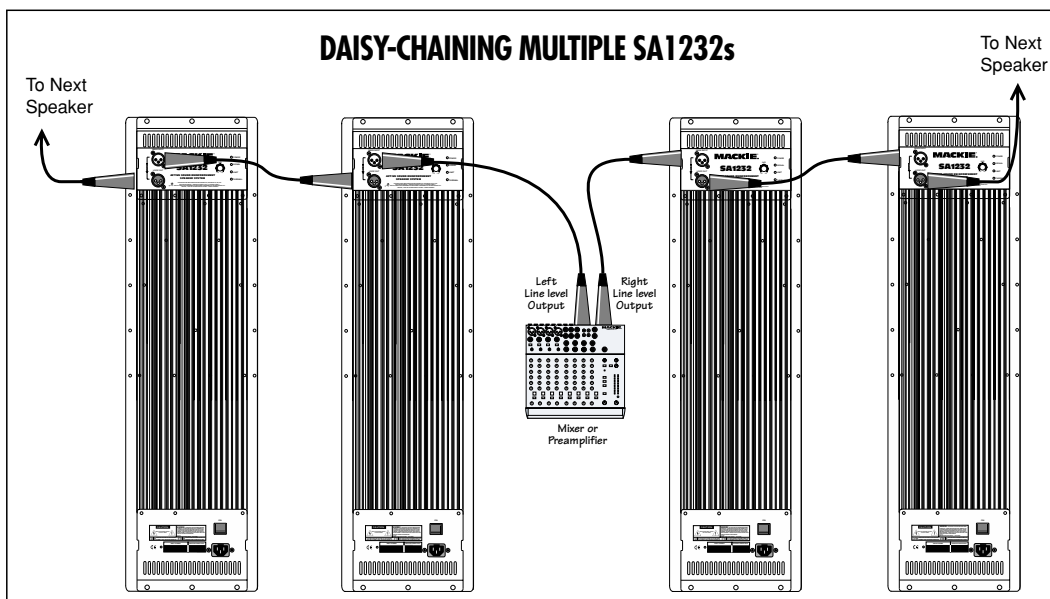

CONNECTIONS

The SA1232 has one female XLR input that accepts a balanced line-level signal. When connecting a balanced signal, be sure it's wired per AES (Audio Engineering Society) standards:

	XLR
Hot (+)	Pin 2
Cold (-)	Pin 3
Shield (Ground)	Pin 1

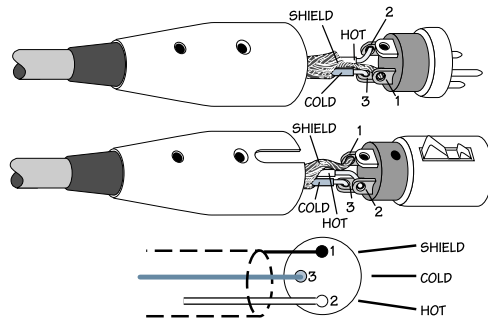

Balanced XLR Connectors

There is also a male XLR connector labeled LOOP OUT. This is also wired according to the above AES standard.

The LOOP OUT connector allows you to connect more than one SA1232 to your system. Simply plug the signal source (i.e., mixer output) into the first MAIN INPUT jack, and patch that speaker's LOOP OUT jack to the next MAIN INPUT jack, and so on, daisy-chaining multiple speakers.

The LOOP OUT jack is wired straight from the MAIN INPUT connector — there is no electronic circuitry between — so the signal coming out of the LOOP OUT jack is exactly the same as the signal going in.

PLACEMENT

The SA1232 speaker is designed to sit on the floor or stage.



WARNING: The cabinet has no rigging points and is not suitable for rigging. **NEVER** attempt to suspend the SA1232 by its handles.

The SA 1232 should never be pole-mounted.

You can create a horizontal array by placing the cabinets side-by-side. However, you should have a good understanding of the relationship between the splay angle (the angle between the facing sides of the cabinets), the on-axis power, and frequency cancellation effects between cabinets.

When two cabinets are placed side-by-side, the actual splay angle is 20° (determined by a 10° angle on each cabinet side). As the splay angle increases toward the angle of horizontal coverage (90° for the SA1232), the on-axis power decreases, but the frequency response becomes smoother as the comb-filtering effects (caused by the interaction in the area of double-coverage) decrease.



As with any powered components, protect them from moisture. If you are setting them up outdoors, make sure they are under cover if you expect rain.

AC POWER

Be sure the SA1232 is plugged into an outlet that is able to supply the correct voltage specified for your model. If the voltage should drop below 97% of the specified line voltage, the built-in amplifiers will no longer be able to supply rated power. (They will continue to operate down to 80% of the rated line voltage, but won't reach full power, resulting in lower headroom.)

Be sure the electrical service can supply enough amperage for all the components connected to it.

We recommend that a stiff (robust) supply of AC power be used because the amplifiers place high current demands on the AC line. The more power that is available on the line, the louder the speakers will play and the more peak output power will be available for cleaner, punchier bass. A suspected problem of "poor bass performance" is often caused by a weak AC supply to the amplifiers.



CAUTION: Never remove the ground pin on the power cord of the SA1232 or any other component. This is very dangerous.

SA1232 systems are available in 115V and 230V AC configurations. Mackie Designs specifies a specific amount of amperage service availability for individual active cabinets. It is a good rule of thumb, especially in countries using 115V AC power, to know precisely the amount of voltage/amperage service available to operate your active speaker systems safely and to their full output capacity. We have provided specifications relative to minimum amperage requirements that should be used as a general guideline. Additionally, it is necessary to comprehend the demands put upon the AC service when running the cabinets for prolonged periods of time at maximum output levels. Depending on the source material and level, cabinets running on 115V AC can demand as much as 20 amps of peak amperage service. Depending on the type of service available, this could be beyond the capability of your AC system and produce unwanted audible by-products.

	Minimum Amperage	Recommended Service
115V	15 Amps	20 Amps
230V	10 Amps	16 Amps

AC sags, or lack of current can be audible. When running into this type of problem, the anomaly generally encountered is similar to that of a processor compressing the input signal very hard. This is caused by the inability of the toroid transformer to recharge the amplifier capacitors fast enough. As a result, the audio performance gets very thin sounding and you must lower the input level in order for the system to recuperate. This is a very common problem for the pro-audio industry in general. When you begin talking about amplifier systems that deliver high power levels (more than 1,000 watts), the limitations of 115V AC service create problems.

Here are some basic calculations for some high power amplifiers:

Amp Output Power	AC Service	Required Amps
1000 watts	115V	8.7 Amps
1500 watts	115V	13 Amps
2000 watts	115V	17.4 Amps
2500 watts	115V	21.7 Amps
3000 watts	115V	26 Amps

If the signal reproduced were a full bandwidth sine wave, then the above data would be true at full output with an absolutely flat signal. An audio signal presents a distinct problem when it comes to the reproduction of transient signals found in the typical programs. For a very short time, the amplifier's power supply could require up to four times the amperage as it tries to reproduce a 6 dB peak. This is especially true of subwoofer amplifier systems trying to reproduce frequencies below 50 Hz, which is the frequency that AC power usually travels at. The SA1232 amplifiers have extremely robust toroidal transformers and use a large number of capacitors. Toroidal power supplies have one huge advantage over other types of supplies, which is their ability to provide higher output beyond their nominal rating. For a very short period of time, a well designed 2500 watt transformer can deliver up to

5000 watts of power. This provides the headroom necessary to deal with the peak transient signals that must be reproduced.

The AC current supplied to the active speaker is especially critical to the overall performance of the audio system. In light of the limitations created by standard 115V service, we have a list of suggestions that will help you avoid problems.

AC Recommended Checklist

- Always check your installation/set up for available AC supply rated circuit amperage
- Locate the main electrical board for breaker location
- Make sure you are not sharing the AC supply for amplifiers with lighting or other services
- Whenever possible, specify 20 amp (15 minimum) service for individual boxes
- Use 16 gauge AC cable as a minimum standard.

The 230 volt AC systems are more stable and run into far fewer current supply problems. In fixed applications where 220-230 volt service is available, we highly recommend using the SA1232 in 230 volt mode. The power supply in the SA1232 can be switched between 115 volt and 230 volt setting. Contact your local service center or Mackie Designs for information.

THERMAL CONSIDERATIONS

The SA1232 has three powerful built-in amplifiers capable of producing a combined 1300 watts of power. As amplifiers produce heat, it is important to dissipate the heat as quickly as possible. This results in increased reliability and longevity for the amplifier.

The amplifier module is mounted on a large heatsink, which is cooled by convection where cool air is drawn through its fins, carrying the heat away. In order for this convection cooling to work efficiently, it is important to provide adequate airspace behind the loudspeaker. When you position the SA1232, we recommend leaving at least six inches of air space behind it.

In the unlikely event of the amplifier overheating, a built-in thermal switch will activate, which mutes the signal and lights the THERMAL LED. When the amplifier has cooled down to a safe operating temperature, the thermal switch resets itself, and the SA1232 resumes normal operation.

If the thermal switch activates frequently, try turning down the level control a notch or two on the mixing console (or the back of the SA1232) to avoid overheating the amplifier.

If the temperature in the room is too high, it could cause the amplifier to overheat. In this case, you should try aiming a fan at the rear panel to move more air through the fins.

SERVICE INFORMATION

Warranty Service

If you think your loudspeaker has a problem, please do everything you can to confirm it before calling for service, including reading through the following Troubleshooting section. Doing so might save you from being deprived of your Mackie loudspeaker.

Of all Mackie products returned for service (which is hardly any at all), many are coded “CND” — Could Not Duplicate— which usually means the problem lay somewhere else in the system. The following troubleshooting tips may sound obvious, but here are some things you can check:

Troubleshooting

No power

- Our favorite question: Is it plugged in? Make sure the AC outlet is live (check with a tester or lamp).
- Our next favorite question: Is the POWER switch on? If not, try turning it on.
- Is the POWER LED on the rear panel glowing green? If not, make sure the AC outlet is live. If so, refer to “No sound” below.
- The internal AC line fuse may be blown. This is not a user serviceable part. If you suspect the AC line fuse is blown, please see the “Repair” section next.

No sound

- Is the input LEVEL control for the input source turned all the way down? Verify that all the volume controls in the system are properly adjusted.
- Is the signal source working (and making union scale)? Make sure the connecting cables are in good repair and securely connected at both ends. Make sure the output volume (gain) control on the mixing console is turned up sufficiently to drive the inputs of the speaker.
- Make sure the mixer does not have a Mute on or a Processor loop engaged. If you find something like this, make sure the volume/gain is turned down before disengaging the offending switch.

- Is the THERMAL indicator lit red on the rear panel? Make sure there is at least six inches of free space behind the SA1232.

Poor bass performance

- Check the polarity of the connections between the mixer and the loudspeakers. You may have your positive and negative connections reversed at one end of one cable, causing one loudspeaker to be out-of-phase.

Poor sound

- Is it loud and distorted? Make sure that you’re not overdriving a stage in the signal chain. Verify that all level controls are set properly.
- Is the input connector plugged completely into the jack? Be sure all connections are secure. It’s a good idea to periodically clean all electrical connections with a non-lubricating electrical contact cleaner.

Noise

- Make sure all connections to the active loudspeakers are good and sound.
- Make sure none of the signal cables are routed near AC cables, power transformers, or other EMI-inducing devices.
- Is there a light dimmer or other SCR-based device on the same AC circuit as the SA1232? Use an AC line filter or plug the SA1232 into a different AC circuit.

Hum

- Try disconnecting the cable connected to the MAIN INPUT jack. If the noise disappears, it could be a “ground loop,” rather than a problem with the SA1232. Try some of the following troubleshooting ideas:
- Use balanced connections throughout your system for the best noise rejection.
- Whenever possible, plug all the audio equipment’s linecords into outlets which share a common ground. The distance between the outlets and the common ground should be as short as possible.

Repair

Service for the SA1232 is available only from one of our authorized domestic service stations or at the factory service center located in Whitinsville, Massachusetts. Service outside the United States can be obtained through local dealers or distributors.

If your SA1232 needs service, please follow these instructions:

1. Review the preceding troubleshooting suggestions. Please.
2. Call Tech Support at 1-800-258-6883, 7am to 5pm PST, to explain the problem in detail. They will ask you all sorts of impertinent questions in the hope of sorting out the problem. If it appears that the SA1232 needs repair, request an RA (Return Authorization) number. Have your loudspeaker's serial number ready. You must have an RA number before you can obtain service at the factory or an authorized service center.
3. Keep this user's manual. We don't need it to repair the loudspeaker.
4. Pack the loudspeaker in its original packaging, including protective wrap, endcaps, and box. *This is very important.* When you call for the RA number, please let Tech Support know if you need new packaging. *Mackie is not responsible for any damage that occurs due to non-factory packaging.*
5. Include a legible note stating your name, shipping address (no P.O. boxes), daytime phone number, RA number, and a detailed description of the problem, including how we can duplicate it.
6. Write the RA number in **BIG PRINT** on top of the box.
7. Ship the loudspeaker to us. We suggest insurance for all forms of cartage. Ship to this address:

Mackie/EAW Service
Building #11
One Main Street
Whitinsville, MA 01588

8. We'll try to fix the loudspeaker in three to five business days. Ask Tech Support for current turnaround times when you call for your RA number. The product **MUST** be packaged in its original packing box and have the RMA number appear on the box. Once it is repaired, we'll ship it back to you the same way in which it was received. This paragraph does not necessarily apply to non-warranty service.

CARE AND MAINTENANCE

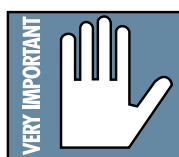

Your Mackie loudspeakers will provide many years of reliable service if you follow these guidelines:

- Avoid exposing the loudspeakers to moisture. If they are set up outdoors, be sure they are under cover if you expect rain.
- Avoid exposure to extreme cold (below freezing temperatures). If you must operate the loudspeakers in a cold environment, warm up the voice coils slowly by sending a low-level signal through them for about 15 minutes prior to high-power operation.
- Use a slightly damp cloth with a mild soap solution to clean the cabinets. Only do this when the power is turned off. Avoid getting moisture into any of the openings of the cabinet, particularly where the drivers are located.

SA1232 SPECIFICATIONS

Acoustic Performance

-3 dB points	45 Hz-18 kHz
-10 dB points	38 Hz-20 kHz
Directivity Factor; Q (DI)	13.2 (11.2), averaged 2 kHz to 10 kHz
System Sensitivity ¹	103 dB, 1W@1m
Max SPL long-term	130 dB
Max SPL Peak	136 dB
Crossover	24 dB/octave @ 700 Hz and 3000 Hz

Input/Output

Input	Bal/Unbal Female XLR
Loop-Through (parallel w/input)	Bal/Unbal Male XLR
Level Control	Rotating knob (-15 to + 5 dB), center detent @ 0 dB

Amplifiers

Total Amplifier Power	1300 watts rms continuous*
High Frequency	100 watts
Type	Class AB
Rated THD	0.03 %
Mid Frequency	100 watts
Type	Class AB
Rated THD	0.03 %
Low Frequency	1100 watts
Type	Class G Hybrid
Rated THD	0.03 %

*Rated power is continuous rms wattage into transducer's minimum rated impedance @ 1 kHz for HF and MF amps and 100 Hz for LF amps

High-Frequency Section

Diaphragm Size	1.75"
Horn Exit Diameter	1"
Phase Plug	3-Slot Optimized Geometry
Diaphragm Material	Damped titanium
Magnet Type	Neodymium

Mid-Frequency Section

Diaphragm Size	6"
Voice Coil Diameter	2"
Phase Plug	Optimized Geometry
Diaphragm Material	Epoxy-reinforced Cellulose
Magnet Type	Neodymium

Mid/High Horn Design

Horizontal Coverage (-6 dB)	90° 1 kHz to 10 kHz avg.
Vertical Coverage (-6 dB)	40° 1 kHz to 10 kHz avg.
Type	Constant Directivity
Design Feature	Optimized Wavefront High/Mid Integration

Low Frequency Section

Number of Drivers	2
Woofer Size	12"
Voice Coil Diameter	3" with Inside/Outside winding
Diaphragm Material	Epoxy-reinforced Cellulose
Magnet Type	Ferrite

Construction Features

Basic Design	Trapezoidal
Material	13-ply Baltic birch, resin end caps
Finish	Wear-resistant textured black PVC vinyl
Handles	One on each side, One top, One Bottom
Grille	Perforated metal with weather- resistant coating

Line Input Power

Power Consumption	450 W long term with IEC pink noise and limiter on
US	120 VAC, 60 Hz Recommended Amperage Service: 20 amps
Europe	230 VAC, 50 Hz Recommended Amperage Service: 16 amps
AC Connector	3-pin IEC 250 VAC

Control System Functions

Electronic Crossover
Phase Alignment
Time Correction
Equalization
Parametric Equalization

Safety Features

Protection	Low Frequency Dynamic Bass Protection, RMS Limiting, Power Supply and Amplifier Thermal Protection
Display LEDs	Power ON, Signal Present, Limit, Thermal (Cool Down Auto Reset)

Physical

Height	50.0 in/127.0 cm
Front Width	19.1 in/48.5 cm
Back Width	13.9 in/35.3 cm
Depth	18.1 in/46.0 cm
Weight	132 lb/60 kg
Mounting Methods	Floor mount only. The SR1530 should never be pole-mounted. The cabinet has no rig- ging points and is not suitable for flying. Never attempt to sus- pend the cabinet by its handles.

¹ Measured on-axis in the far field, referenced back to 1 watt rms from maximum power and to 1 meter distance using the inverse square law.

Architects and Engineers' Specifications

The active three-way, full-range loudspeaker system shall incorporate two 12-inch low-frequency (LF) transducers, a 6-inch horn loaded mid-frequency (MF) transducer, and a 1-inch exit, 1.75-inch titanium dome compression driver high-frequency (HF) transducer. The LF drivers shall be mounted in a vented enclosure tuned for optimum low-frequency response. The MF and HF transducers shall be loaded on a symmetrical constant-directivity horn assembly designed for wide dispersion.

The system shall have a nominal coverage pattern of 90° (horizontal) x 40° (vertical). System frequency response shall vary no more than ± 3 dB from 45 Hz to 18 kHz measured on axis. The loudspeaker shall incorporate a Class G low-frequency amplifier capable of delivering 1100 watts rms over a frequency range of 20 Hz–700 Hz. The system shall incorporate two Class AB 100 watt rms amplifiers specifically designed to power the MF and HF drivers over the range of 700 Hz–3000 Hz and 3000 Hz–20 kHz respectively. The amplifiers shall be mounted on an aluminum heat sink, which shall be mounted on the rear of the speaker system, and shall be convection cooled.

The rear mounted amplifier assembly shall comprise separate signal and AC power panels separated by a large aluminum heat sink. The signal input panel shall contain an input and loop-through XLR, a volume level control, and four status LEDs for Power ON, Signal Present, Limit, and Thermal functions. The system shall accept a standard line-level signal via the XLR input connector. The power switch and IEC AC connector shall be located on the power panel.

Thermal protection shall be provided by a thermal sensor mounted on the heat sink, which monitors the heat sink temperature and triggers the thermal protection circuit should the temperature exceed 158° F (70° C). The Thermal LED shall light and the input signal shall be muted until the heat sink cools to a safe operating level, at which point the thermal protection circuit auto-resets and normal operation resumes.

Overload protection shall be provided by a limiter circuit, which monitors the low-frequency amplifier output and reduces the input level to the amplifier should the amplifier output begin to clip.

The loudspeaker enclosure shall have a trapezoidal shape and shall incorporate two side handles, one on each side, and a top and bottom relocation handle. The enclosure shall be constructed of a combination multi-ply wood and high-pressure injected structural resin, with a black PVC vinyl finish. The front of the loudspeaker shall be covered with a powder coated, weather-resistant perforated steel grille.

The active three-way full-range loudspeaker system shall be a Mackie Designs SA1232.

Dimensions

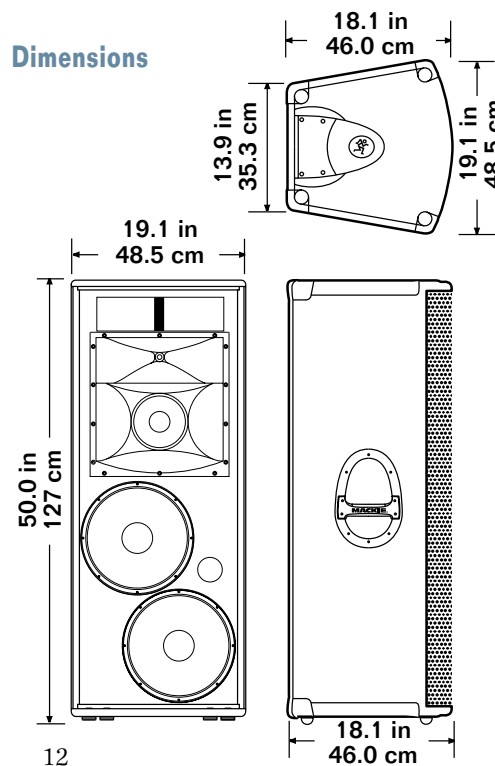

Disclaimer

Since we are always striving to make our products better by incorporating new and improved materials, components, and manufacturing methods, we reserve the right to change these specifications at any time without notice.

“Mackie” and the “Running Man” figure are trademarks or registered trademarks of Mackie Designs Inc.

All other brand names mentioned are trademarks or registered trademarks of their respective holders, and are hereby acknowledged.

©2003 Mackie Designs Inc. All Rights Reserved.

Graphs

SA1232 Frequency Response On-Axis

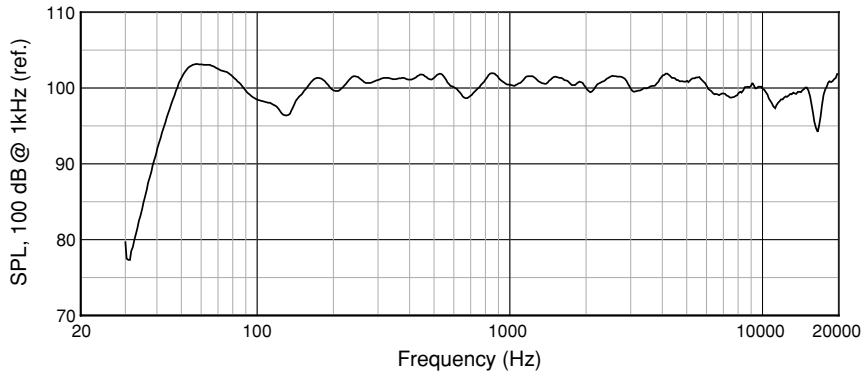

SA1232 Beamwidth vs. Frequency

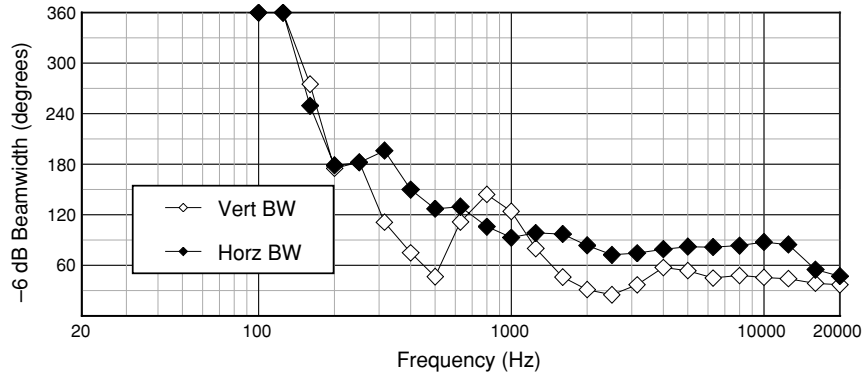

SA1232 Directivity Index

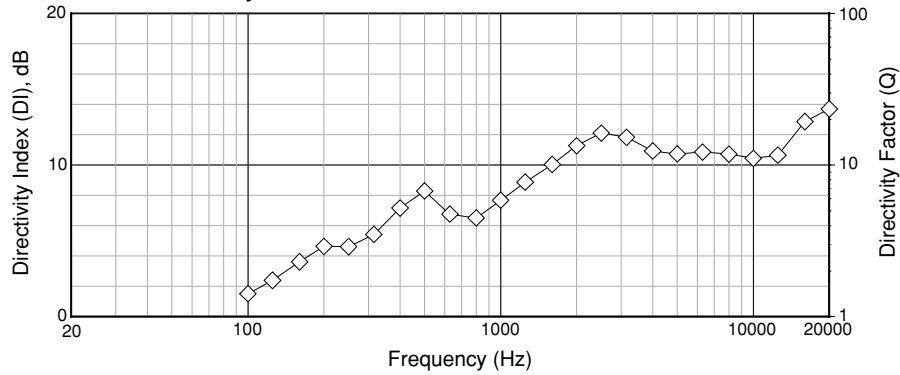

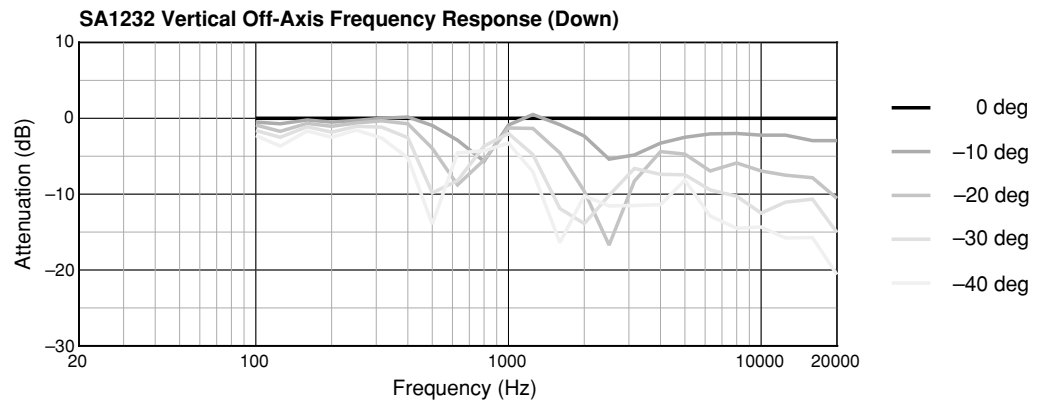
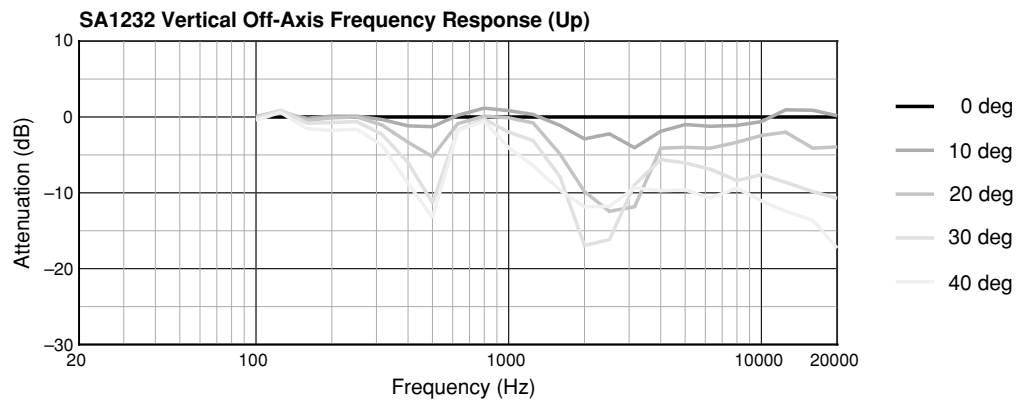
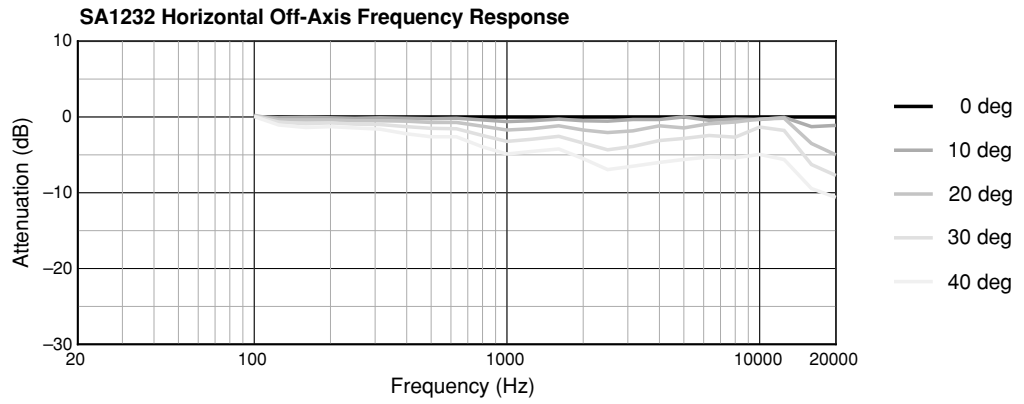



SA1232 LIMITED WARRANTY

Please keep your sales receipt in a safe place.

A. Mackie warrants all materials, workmanship and proper operation of this SA1232 for a period of **one year** from the original date of purchase. If you complete the optional questionnaire portion of the Product Registration Card, the warranty will be extended for an **additional FOUR years** with the following exception: warranty on all its loudspeaker components including woofers and compression drivers are only warranted for an additional one year (for a total of two years). If any defects are found in the materials or workmanship or if the product fails to function properly during the applicable warranty period, Mackie, at its option, will repair or replace the product. This warranty applies only to equipment sold and delivered within the U.S. by Mackie or its authorized dealers.

B. Failure to return the card will not void the 1-year warranty.

C. Service and repairs of Mackie products are to be performed **only** at the factory (see D below) OR at an Authorized Mackie Service Center (see E below). Unauthorized service, repairs, or modification will void this warranty.

D. To obtain factory service:

1. Call Mackie at 800/258-6883, 8AM to 5PM Monday through Friday (Pacific Time) to get a Return Authorization (RA). Products returned without an RA number will be refused.

2. Pack the SA1232 in its original shipping carton. If you do not have the carton, just ask for one when you get your RA number, and we'll send a shipping carton out promptly. More information on packing can be found in the *Service* section of this manual. Also include a note explaining exactly how to duplicate the problem, a copy of the sales receipt with price and date showing, and your return street address (no P.O. boxes or route numbers, please!). If we cannot duplicate the problem at the Mackie Factory or establish the starting date of your Limited Warranty, we may, at our option, charge for service time.

3. Ship the product in its original shipping carton, **freight prepaid** to:

Mackie/EAW Service
Building #11
One Main Street
Whitinsville, MA, 01588, USA

IMPORTANT: Make sure that the RA number is plainly written on the shipping carton.

E. To obtain service from an Authorized Mackie Service Center:

1. Call Mackie at 800/258-6883, 8AM to 5PM Monday through Friday (Pacific Time) to get:

1) The name and address of your nearest Mackie Authorized Service Center and 2) A return authorization (RA). You must have an RA number before taking your unit to a service center.

2. Make sure that you have a copy of your loudspeaker's sales receipt from the store where you bought the product. It is necessary to establish purchase date and thus determine whether or not your loudspeaker is still under warranty. If you can't find it, the Authorized Service Center may charge you for repairs even if your loudspeaker is still covered by Mackie's 1-Year Limited Warranty.

3. Make sure that the problem can be duplicated. If you bring your loudspeaker to an Au-

thorized Service Center and they can't find any thing wrong with it, you may be charged a service fee.

4. If the Mackie Authorized Service Center is located in another city, pack the loudspeaker in its original shipping carton. More information on packing can be found in the *Service* section of this manual.

5. Contact the Mackie Authorized Service Center to arrange service or bring the loudspeaker to them.

F. Mackie and Mackie Authorized Service Centers reserve the right to inspect any products that may be the subject of any warranty claims before repair or replacement is carried out. Mackie and Mackie Authorized Service Centers may, at their option, require proof of the original date of purchase in the form of a dated copy of the original dealer's invoice or sales receipt. Final determination of warranty coverage lies solely with Mackie Designs Inc. or its Authorized Service Centers.

G. Mackie loudspeakers returned to Mackie and deemed eligible for repair or replacement under the terms of this warranty will be repaired or replaced within thirty days of receipt by Mackie. Products returned to Mackie that do not meet the terms of this Warranty will be repaired and returned C.O.D. with billing for labor, materials, return freight, and insurance. Products repaired under warranty at Mackie's factory will be returned freight prepaid by Mackie to any location within the boundaries of the USA.

H. Mackie assumes no responsibility for the quality or timeliness of repairs performed by Mackie Authorized Service Centers.

I. This warranty is extended to the original purchaser and to anyone who may subsequently purchase this product within the applicable warranty period.

J. This is your sole warranty. Mackie does not authorize any third party, including any dealer or sales representative, to assume any liability on behalf of Mackie Designs or to make any warranty for Mackie Designs.

K. THE WARRANTY GIVEN ON THIS PAGE IS THE SOLE WARRANTY GIVEN BY MACKIE AND IS IN LIEU OF ALL OTHER WARRANTIES, EXPRESS AND IMPLIED, INCLUDING THE WARRANTIES OF MERCHANTABILITY AND FITNESS FOR A PARTICULAR PURPOSE. THE WARRANTY GIVEN ON THIS PAGE SHALL BE STRICTLY LIMITED IN DURATION TO ONE YEAR FROM THE DATE OF ORIGINAL PURCHASE FROM AN AUTHORIZED MACKIE DEALER. UPON EXPIRATION OF THE APPLICABLE WARRANTY PERIOD, MACKIE SHALL HAVE NO FURTHER WARRANTY OBLIGATION OF ANY KIND. MACKIE SHALL NOT BE LIABLE FOR ANY INCIDENTAL, SPECIAL, OR CONSEQUENTIAL DAMAGES THAT MAY RESULT FROM ANY DEFECT IN THE MACKIE PRODUCT OR ANY WARRANTY CLAIM. Some states do not allow exclusion or limitation of incidental, special, or consequential damages or a limitation on how long warranties last, so some of the above limitations and exclusions may not apply to you. This warranty provides specific legal rights and you may have other rights which vary from state to state.



*Some of the
people at our
factory who helped
design, build, sell,
and support your
product.*

MACKIE®

Mackie Designs Inc.

16220 Wood-Red Rd. NE • Woodinville, WA 98072 • USA
US & Canada: 800/898-3211

Europe, Asia, Central & South America: 425/487-4333

Middle East & Africa: 31-20-654-4000

Fax: 425/487-4337 • www.mackie.com

E-mail: sales@mackie.com

Free Manuals Download Website

<http://myh66.com>

<http://usermanuals.us>

<http://www.somanuals.com>

<http://www.4manuals.cc>

<http://www.manual-lib.com>

<http://www.404manual.com>

<http://www.luxmanual.com>

<http://aubethermostatmanual.com>

Golf course search by state

<http://golfingnear.com>

Email search by domain

<http://emailbydomain.com>

Auto manuals search

<http://auto.somanuals.com>

TV manuals search

<http://tv.somanuals.com>