

HD1521

*2-Way High-Definition
Powered Loudspeaker*

OWNER'S MANUAL

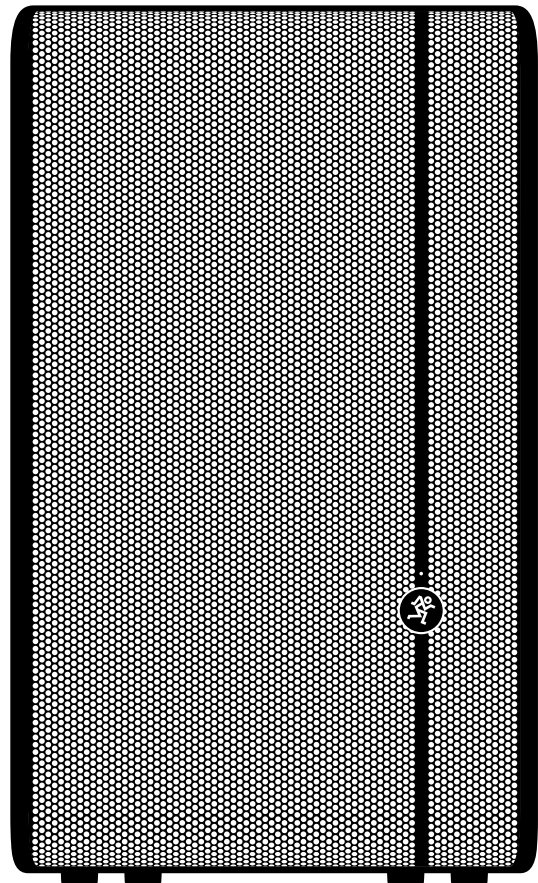

MACKIE®

Important Safety Instructions

1. Read these instructions.
2. Keep these instructions.
3. Heed all warnings.
4. Follow all instructions.
5. Do not use this apparatus near water.
6. Clean only with a dry cloth.
7. Do not block any ventilation openings. Install in accordance with the manufacturer's instructions.
8. Do not install near any heat sources such as radiators, heat registers, stoves, or other apparatus (including amplifiers) that produce heat.
9. Do not defeat the safety purpose of the polarized or grounding-type plug. A polarized plug has two blades with one wider than the other. A grounding-type plug has two blades and a third grounding prong. The wide blade or the third prong are provided for your safety. If the provided plug does not fit into your outlet, consult an electrician for replacement of the obsolete outlet.
10. Do not overload wall outlets and extension cords as this can result in a risk of fire or electric shock.
11. Protect the power cord from being walked on or pinched particularly at plugs, convenience receptacles, and the point where they exit from the apparatus.
12. Only use attachments/accessories specified by the manufacturer.
13. Use only with a cart, stand, tripod, bracket, or table specified by the manufacturer, or sold with the apparatus. When a cart is used, use caution when moving the cart/apparatus combination to avoid injury from tip-over.
14. Unplug this apparatus during lightning storms or when unused for long periods of time.
15. Refer all servicing to qualified service personnel. Servicing is required when the apparatus has been damaged in any way, such as power-supply cord or plug is damaged, liquid has been spilled or objects have fallen into the apparatus, the apparatus has been exposed to rain or moisture, does not operate normally, or has been dropped.
16. This apparatus shall not be exposed to dripping or splashing, and no object filled with liquids, such as vases or beer glasses, shall be placed on the apparatus.
17. This apparatus has been designed with Class-I construction and must be connected to a mains socket outlet with a protective earthing connection (the third grounding prong).
18. The MAINS plug or an appliance coupler is used as the disconnect device, so the disconnect device shall remain readily operable.



19. NOTE: This equipment has been tested and found to comply with the limits for a Class B digital device, pursuant to part 15 of the FCC Rules. These limits are designed to provide reasonable protection against harmful interference in a residential installation. This equipment generates, uses, and can radiate radio frequency energy and, if not installed and used in accordance with the instructions, may cause harmful interference to radio communications. However, there is no guarantee that interference will not occur in a particular installation. If this equipment does cause harmful interference to radio or television reception, which can be determined by turning the equipment off and on, the user is encouraged to try to correct the interference by one or more of the following measures:
 - Reorient or relocate the receiving antenna.
 - Increase the separation between the equipment and the receiver.
 - Connect the equipment into an outlet on a circuit different from that to which the receiver is connected.
 - Consult the dealer or an experienced radio/TV technician for help.

CAUTION: Changes or modifications to this device not expressly approved by LOUD Technologies Inc. could void the user's authority to operate the equipment under FCC rules.

20. This apparatus does not exceed the Class A/Class B (whichever is applicable) limits for radio noise emissions from digital apparatus as set out in the radio interference regulations of the Canadian Department of Communications.

ATTENTION — *Le présent appareil numérique n'émet pas de bruits radioélectriques dépassant les limites applicables aux appareils numériques de class A/de class B (selon le cas) prescrites dans le règlement sur le brouillage radioélectrique édicté par les ministere des communications du Canada.*

21. Exposure to extremely high noise levels may cause permanent hearing loss. Individuals vary considerably in susceptibility to noise-induced hearing loss, but nearly everyone will lose some hearing if exposed to sufficiently intense noise for a period of time. The U.S. Government's Occupational Safety and Health Administration (OSHA) has specified the permissible noise level exposures shown in the following chart. According to OSHA, any exposure in excess of these permissible limits could result in some hearing loss. To ensure against potentially dangerous exposure to high sound pressure levels, it is recommended that all persons exposed to equipment capable of producing high sound pressure levels use hearing protectors while the equipment is in operation. Ear plugs or protectors in the ear canals or over the ears must be worn when operating the equipment in order to prevent permanent hearing loss if exposure is in excess of the limits set forth here:

	CAUTION AVIS	
RISK OF ELECTRIC SHOCK. DO NOT OPEN RISQUE DE CHOC ELECTRIQUE. NE PAS OUVRIR		
CAUTION: TO REDUCE THE RISK OF ELECTRIC SHOCK DO NOT REMOVE COVER (OR BACK) NO USER-SERVICEABLE PARTS INSIDE. REFER SERVICING TO QUALIFIED PERSONNEL ATTENTION: POUR EVITER LES RISQUES DE CHOC ELECTRIQUE, NE PAS ENLEVER LE COUVERCLE. AUCUN ENTRETIEN DE PIECES INTERIEURES PAR L'USAGER. CONFIER L'ENTRETIEN AU PERSONNEL QUALIFIE. AVIS: POUR EVITER LES RISQUES D'INCENDIE OU D'ELECTROCUTION, N'EXPOSEZ PAS CET ARTICLE A LA PLUIE OU A L'HUMIDITE		

The lightning flash with arrowhead symbol within an equilateral triangle is intended to alert the user to the presence of uninsulated "dangerous voltage" within the product's enclosure, that may be of sufficient magnitude to constitute a risk of electric shock to persons.
Le symbole éclair avec point de flèche à l'intérieur d'un triangle équilatéral est utilisé pour alerter l'utilisateur de la présence à l'intérieur du coffret de "voltage dangereux" non isolé d'ampleur suffisante pour constituer un risque d'électrocution.

The exclamation point within an equilateral triangle is intended to alert the user of the presence of important operating and maintenance (servicing) instructions in the literature accompanying the appliance.
Le point d'exclamation à l'intérieur d'un triangle équilatéral est employé pour alerter les utilisateurs de la présence d'instructions importantes pour le fonctionnement et l'entretien (service) dans le livret d'instruction accompagnant l'appareil.

Duration, per day in hours	Sound Level dBA, Slow Response	Typical Example
8	90	Duo in small club
6	92	
4	95	Subway Train
3	97	
2	100	Very loud classical music
1.5	102	
1	105	Steve screaming at Troy about deadlines
0.5	110	
0.25 or less	115	Loudest parts at a rock concert

WARNING — To reduce the risk of fire or electric shock, do not expose this apparatus to rain or moisture.

- 22. Rigging Precautions:** When mounting or suspending loudspeaker enclosures, it is essential that load ratings, rigging techniques, and special safety considerations be appropriate for the installation. Use only the mounting/rigging points on the loudspeaker enclosure intended for this purpose. The user must determine the load requirements, dynamic loading, and any other contributing factors affecting the loudspeaker installation. The user must determine the proper design factor for specific applications and the required load rating of the connection to structure. Comply with all applicable federal, state, and local regulations.

We strongly recommend the following rigging system practices:

- **Documentation:** Thoroughly document the mounting/rigging design with detailed drawings and parts lists.
- **Analysis:** Have a licensed structural engineer or other qualified professional review and approve the mounting/rigging design before its implementation.
- **Installation:** Use personnel experienced and qualified for mounting/rigging loudspeakers in accordance with and in compliance with all federal, state and local regulations.



DANGER: Loudspeakers should be mounted or suspended only by persons with knowledge of the proper hardware and rigging techniques. When stacking or pole-mounting loudspeakers, be sure that they are stabilized and secured from falling over or being accidentally pushed over. Failure to follow these precautions may result in damage to the equipment, personal injury, or death.

Introduction

The HD1521 Powered Loudspeaker represents the first step into portable high-definition live sound, providing precise, articulate full-range sound at the high-output levels demanded of modern PA systems. Two Class-D Fast Recovery™ amplifiers efficiently drive 1600 Watts of total system power, providing maximum output with minimal distortion. True high-definition sound is possible thanks to an arsenal of technological innovations including our patented acoustic correction processing that was previously only available on high-end stadium touring systems. This complex processing, along with a phase-coherent electronic crossover and transducer time-alignment provide unparalleled acoustic accuracy that has to be heard to be believed.

The 15" neodymium woofer and heat-treated titanium compression driver are custom designed by the award winning engineering team at EAW, delivering the ultimate in both quality and performance. A user-adjustable 3-band contour EQ is built into the loudspeaker and features a sweepable mid frequency for precise tonal shaping.

All of these high-end components are housed in a rugged, all-wood enclosure that not only protects, but allows for multiple mounting options including flying and pole mounting. The HD1521 brings high-definition sound to the world of portable PA systems.

Contents

IMPORTANT SAFETY INSTRUCTIONS	2
INTRODUCTION	3
FEATURES	3
HOOKUP DIAGRAMS	4
REAR PANEL FEATURES	5
PLACEMENT	7
ROOM ACOUSTICS	7
RIGGING	8
THERMAL CONSIDERATIONS	9
AC POWER	9
CARE AND MAINTENANCE	9
APPENDIX A: SERVICE INFORMATION	10
APPENDIX B: CONNECTIONS	11
APPENDIX C: TECHNICAL INFORMATION	12
HD1521 BLOCK DIAGRAM	13
HD1521 GRAPHS AND DIMENSIONS	14
HD1521 LIMITED WARRANTY	15

Features

- 1600W of ultra-efficient Class-D Fast Recovery™ amplification
 - LF 700W RMS / 1400W peak
 - HF 100W RMS / 200W peak
- High-definition audio processing includes:
 - Revolutionary patented acoustic correction algorithms
 - Transducer time alignment and phase correction
 - Precision 2-way crossover
- Custom designed transducers by EAW
 - 15" neodymium woofer with 3" voice coil
 - 1.75" compression driver with heat-treated titanium diaphragm
- User-adjustable 3-band contour EQ with sweepable mid-frequency
- Ultra-compact and lightweight
- Integrated limiting and protection circuitry
- Rugged all wood cabinet (15mm birch plywood)
- 12 integrated fly points for horizontal and vertical rigging
- Stand / pole mountable

Hookup Diagrams

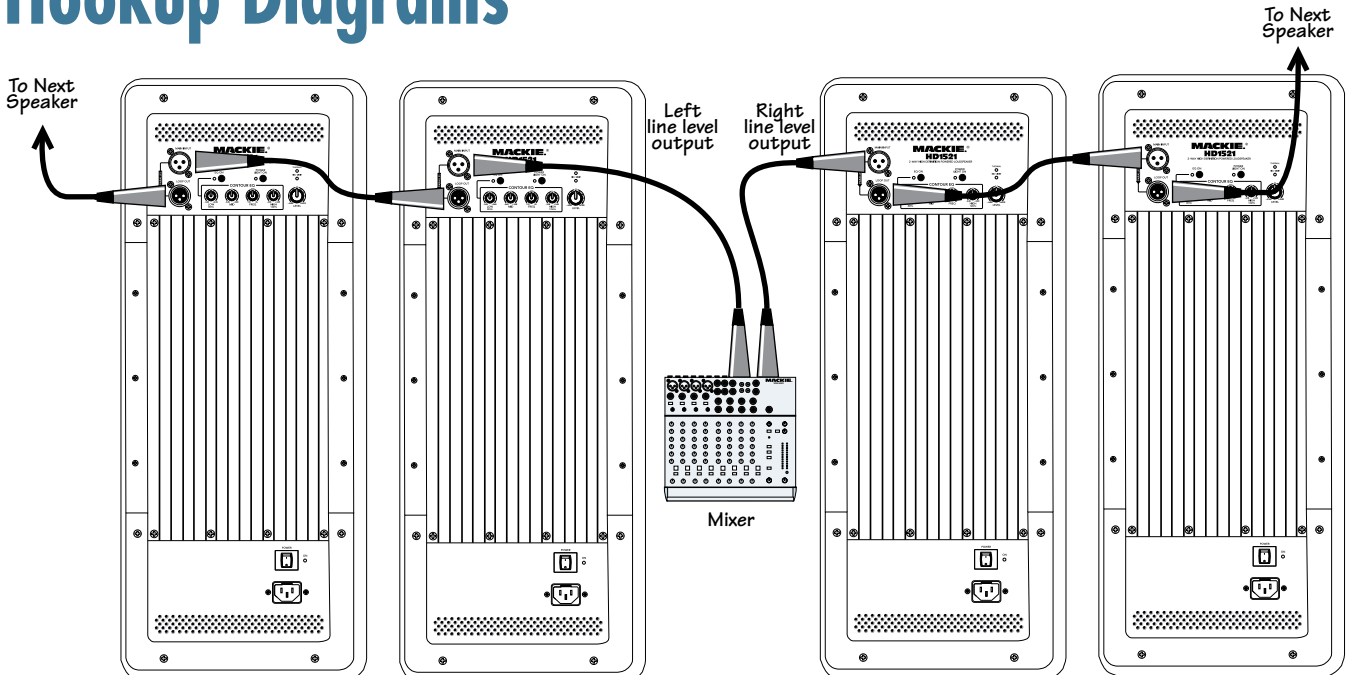

DAISY-CHAINING MULTIPLE HD1521s

HD1521 reproduces all frequencies above the subwoofer's crossover point

HD1521 reproduces all frequencies above the subwoofer's crossover point

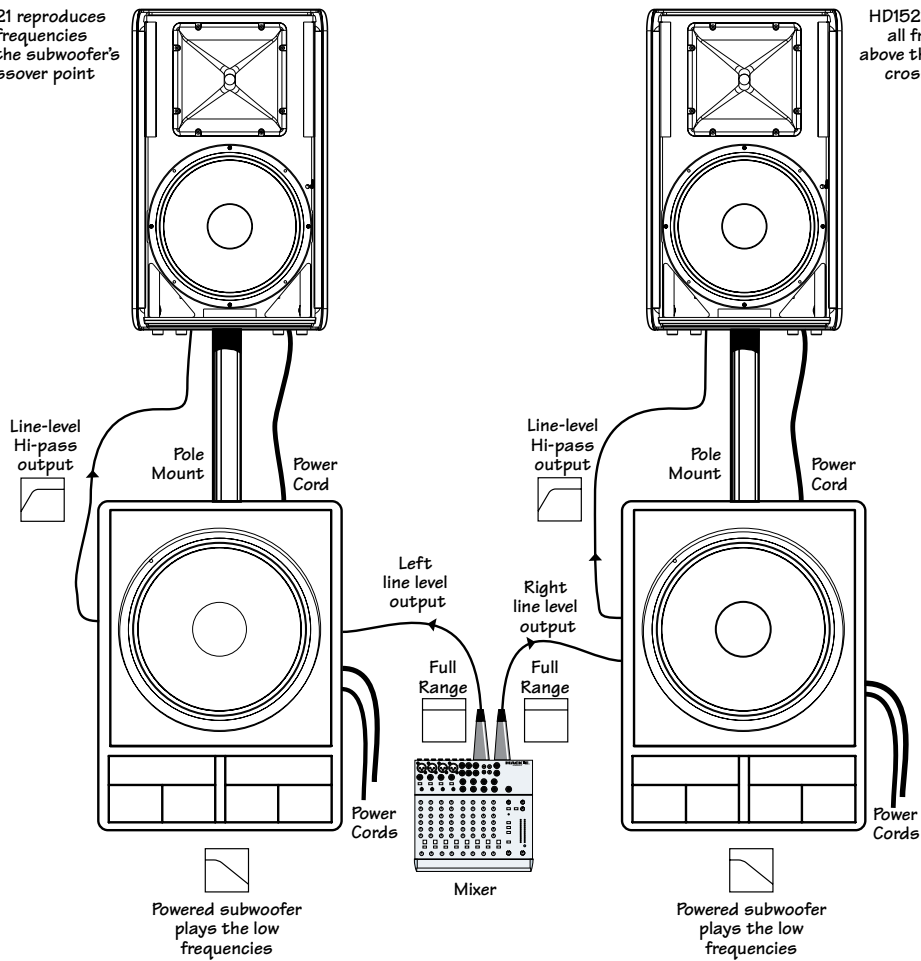

HD1521: 3-WAY SYSTEM WITH POWERED SUBWOOFERS

Rear Panel Features

1. MAIN INPUT

This is a female XLR-type connector that accepts a balanced line-level signal from a mixing console or other signal source.

2. LOOP OUT

This is a male XLR-type connector that produces exactly the same signal that is connected to the main input jack. Use it to daisy-chain several HD1521's together off the same signal source.

Contour EQ

This built-in 3-band EQ allows the HD1521 to be tailored for any sound application. Use it to help compensate for poor room acoustics, boost highs and lows for low-volume applications, or for any other variety of needs.

3. EQ ON

Press this switch in to engage the Contour EQ circuit. The LED next to the switch will light to indicate that the EQ is on. Use this switch to engage or bypass the EQ, or toggle it repeatedly while listening carefully to judge the EQ's effect.

4. LOW

This knob allows up to 3 dB of boost or cut at 80 Hz, with no change in level at the unity (U) mark. This is a shelving EQ.

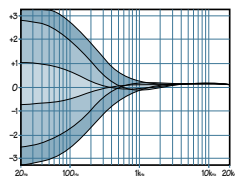

5. MID

This knob allows up to 3 dB of boost or cut at a mid frequency set by the freq knob (6), with no change in level at the unity (U) mark. This is a peaking EQ.

6. FREQ

This knob allows you to adjust the center frequency of the mid-peaking EQ, from 100 Hz to 8 kHz, with 600 Hz at the center position.

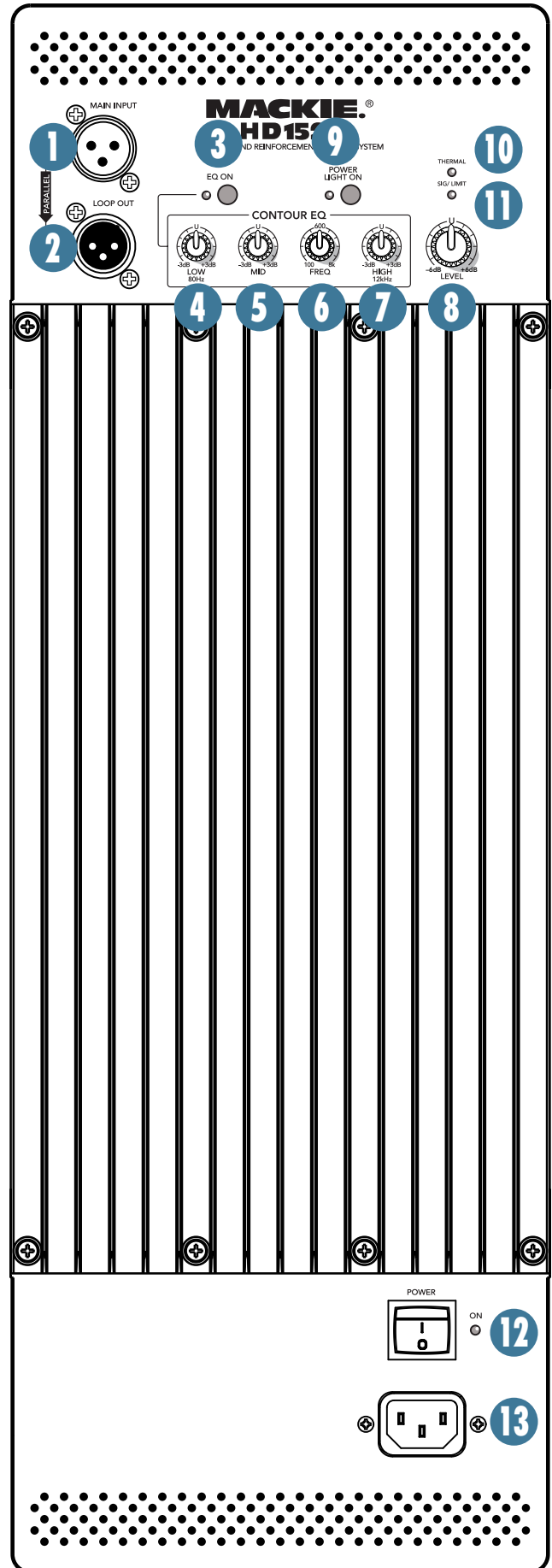
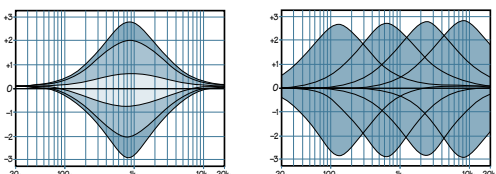

7. HIGH

This knob allows up to 3 dB of boost or cut at 12 kHz, with no change in level at the unity (U) mark. This is a shelving EQ.

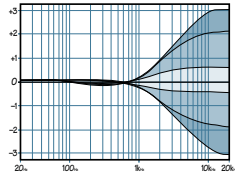

8. LEVEL

This controls the overall signal level at the input to the built-in power amplifiers. It ranges from -6 dB to $+6$ dB of gain. The center detent is 0 dB (unity gain).

9. POWER LIGHT ON

Press this switch in to turn on the front panel power LED if a visual indicator is preferred. The LED next to the switch will light as a reminder.

If this switch is out, and the HD1521 is turned on, the LED on the front of the cabinet will not light, nor will the LED next to the switch.

10. THERMAL LED

The HD1521 is equipped with a thermal protection circuit that monitors the internal temperature of the amplifiers and heatsink. If the temperature exceeds a safe operating level, this indicator lights and the input signal is muted to allow the amplifiers to cool. When the temperature cools to a safe level once again, the thermal protection circuit deactivates, the thermal LED turns off and the HD1521 returns to normal operation.

When the HD1521 is in thermal protect mode, the power LED (12) will remain lit, indicating that the unit is still powered on despite the lack of output. If power light on (9) is engaged, the front panel power LED will go out when in thermal protect mode.



Activation of the thermal protection circuit is an indication that you should take steps to avoid continued thermal problems. See “Thermal Considerations” on page 9.

11. SIG/LIMIT LED

This bi-color LED illuminates green whenever there is a signal present at the main input connector. It senses the signal just after the level control, so adjustments to the level control will affect the sig/limit indicator.

The HD1521 has a built-in limiter that helps to prevent the amplifier outputs from clipping or overdriving the transducers. The sig/limit indicator lights in yellow when the limiter is activated. It's okay for it to blink yellow occasionally, but if it blinks frequently or lights continuously, turn down the level control until it only blinks occasionally.



Excessive limiting may lead to overheating, which in turn trips the thermal protect circuitry and interrupts the performance. See ‘Thermal Considerations’ on page 9 for more information.

12. POWER

Use this switch to turn the HD1521 on and off. The LED next to the switch will illuminate when powered on. The front panel LED will also turn on, but only if the power light on switch (9) is engaged.

Press the bottom of this switch to put the speaker into standby mode. The HD1521 will not function, but the circuits are still live. To remove AC power, either turn off the AC mains supply, or unplug the power cord from the speaker and the AC mains supply.



As a general guide, the powered speakers should be turned on last, after the mixer and other sources. They should also be the first things turned off. This will reduce the possibility of any turn-on, or turn-off thumps in your speakers.

13. IEC AC Receptacle

This jack accepts the supplied 3-prong AC power cord.



Before you plug the AC power cord into the powered loudspeaker, make sure that the voltage of your unit (listed above the IEC AC receptacle) is the same voltage as your local AC mains supply. Use only the power cord supplied. Also, disconnecting the plug's ground pin is dangerous. Don't do it. And no running with scissors either. Let's be safe out there!

Placement



WARNING: Installation should only be done by an experienced technician. Improper installation may result in damage to the equipment, injury or death. Make sure that the loudspeaker is installed in a stable and secure way in order to avoid any conditions that may be dangerous for persons or structures.

The HD1521 speaker is designed to sit on the floor or stage. It may also be pole-mounted via the built-in socket on the bottom of the cabinet. Be sure the pole is capable of supporting the weight of the HD1521. The HD1521 may also be flown horizontally or vertically via its 12 integrated fly points.

Check to make sure that the support surface (e.g., floor, etc.) has the necessary mechanical characteristics to support the weight of the loudspeaker(s).

When pole-mounting loudspeakers, be sure that they are stabilized and secured from falling over or being accidentally pushed over. Failure to follow these precautions may result in damage to the equipment, personal injury, or death.

You can create a horizontal array by placing the cabinets side-by-side. However, you should have a good understanding of the relationship between the splay angle (the angle between the facing sides of the cabinets), the on-axis power, and frequency cancellation effects between cabinets.

When two cabinets are positioned vertically side-by-side, the actual splay angle is 20° (determined by a 10° angle on each cabinet side). As the splay angle increases toward the angle of horizontal coverage (80° for the HD1521), the on-axis power decreases, but the frequency response becomes smoother as the comb-filtering effects (caused by the interaction in the area of double-coverage) decrease.

As with any powered components, protect them from moisture. Avoid installing the loudspeaker in places exposed to harsh weather conditions. If you are setting them up outdoors, make sure they are under cover if you expect rain.

Room Acoustics

The HD1521 loudspeakers are designed to sound neutral; that is, to reproduce the input signal as accurately as possible.

Room acoustics play a crucial role in the overall performance of a sound system. Here are some additional placement tips to help overcome some typical room problems that might arise:

- Avoid placing loudspeakers in the corners of a room. Doing so increases the low frequency output and can cause the sound to be muddy and indistinct.
- Avoid placing loudspeakers against a wall. This, too, increases the low frequency output, though not as much as corner placement. However, this is a good way to reinforce the low frequencies, if so desired.
- Avoid placing the speakers directly on a hollow stage floor. A hollow stage can resonate at certain frequencies, causing peaks and dips in the frequency response of the room. It is better to place the loudspeakers on a sturdy table or stand designed to handle the weight of the HD1521.
- Position the loudspeakers so the high-frequency drivers are 2 to 4 feet above ear level for the audience (make allowances for a standing/dancing in the aisles audience). High frequencies are highly directional and tend to be absorbed much easier than lower frequencies. By providing direct line-of-sight from the loudspeakers to the audience, you increase the overall brightness and intelligibility of the sound system.
- Highly reverberant rooms, like many gymnasiums and auditoriums, are a nightmare for sound system intelligibility. Multiple reflections off the hard walls, ceiling, and floor play havoc with the sound. Depending on the situation, you may be able to take some steps to minimize the reflections, such as putting carpeting on the floors, closing draperies to cover large glass windows, or hanging tapestries or other materials on the walls to absorb some of the sound. However, in most cases, these remedies are not possible or practical. So what do you do? Making the sound system louder generally doesn't work because the reflections become louder, too. The best approach is to provide as much direct sound coverage to the audience as possible. The farther away you are from the speaker, the more prominent will be the reflected sound. Use more speakers strategically placed so they are closer to the back of the audience. If the distance between the front and back speakers is more than about 100 feet, you should use a delay processor to time-align the sound. (Since sound travels about 1 foot per millisecond, it takes about 1/10 of a second to travel 100 feet.)

Keep in mind that the Contour EQ is a great way to compensate for some of these issues.

Rigging

HD1521s may be individually flown horizontally or vertically using M10 X 1.5 X 37 mm forged shoulder eyebolts.



WARNING: Installation should only be done by an experienced technician. Improper installation may result in damage to the equipment, injury or death. Make sure that the loudspeaker is installed in a stable and secure way in order to avoid any conditions that may be dangerous for persons or structures.



WARNING: The cabinet is suitable for rigging via its fly points. NEVER attempt to suspend the HD1521 by its handles.

Rigging Design Practices

Rigging a loudspeaker requires determining:

1. The rigging methods and hardware that meet static, shock, dynamic, and any other load requirements for supporting the loudspeaker from structure.
2. The design factor for and the required WLL (Working Load Limit) for this support.

Mackie strongly recommends the following rigging practices:

1. Documentation: Thoroughly document the design with detailed drawings and parts lists.
2. Analysis: Have a qualified professional, such as a licensed Professional Engineer, review and approve the design before its implementation.
3. Installation: Have a qualified professional rigger do the installation and inspection.
4. Safety: Use adequate safety precautions and back-up systems.

12 Fly Points

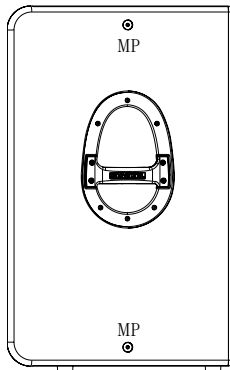

Two per side

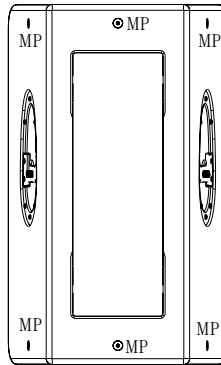

Two on the rear

MP=Mounting Point

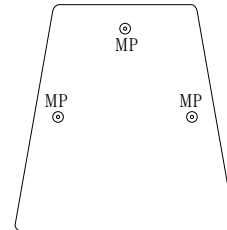

Three each on the top and bottom

Flown Horizontally

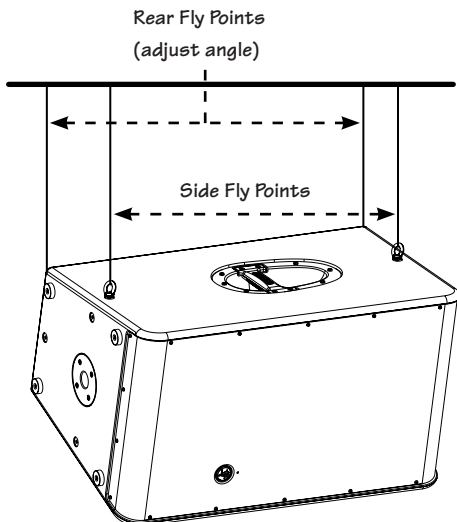

Flown Vertically

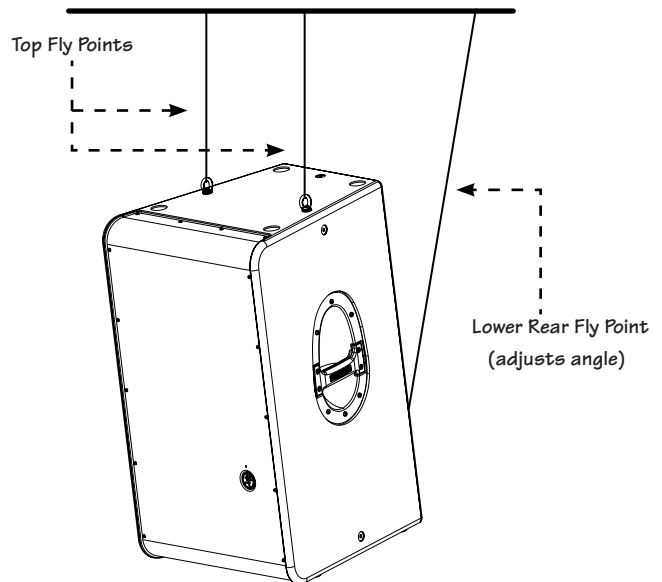

Rigging Hardware and Accessories

Rigging Mackie loudspeakers will invariably require hardware not supplied by Mackie. Various types of load-rated hardware are available from a variety of third-party sources. There are a number of such companies specializing in manufacturing hardware for, designing, and installing rigging systems. Each one of these tasks is a discipline in its own right. Because of the hazardous nature of rigging work and the potential liability, engage companies that specialize in these disciplines to do the work required.

Mackie does offer certain accessory rigging items, primarily for attachment to the hardware integral with the loudspeaker. Some items, such as eyebolts, may be used with a variety of products. While these accessories are intended to facilitate installation, the wide variety of possible installation conditions and array configurations do not permit Mackie to determine their suitability or load rating for any particular application.

Mackie is not in the business of providing complete rigging systems, either as designers, manufacturers, or installers. It is the responsibility of the installer to provide a properly engineered, load-certified rigging system for supporting the loudspeaker from structure.

Rigging Notes

The HD1521's integral mounting points are designed to support only the weight of their own loudspeaker with suitable, external hardware. This means that each HD loudspeaker must be supported independently of any other HD loudspeaker and any other loads.

A minimum of two rigging points must be used to hang an HD1521. More may be used for creating the desired hanging angle as shown in the illustrations on page 8. All mounting points are fully load bearing so any two may be used for rigging; no mounting points are restricted to angle control only.

Thermal Considerations

The HD1521 has two powerful built-in amplifiers capable of producing a combined 800 watts of rms power. As an amplifier works, it produces heat. The higher the signal level, the louder and hotter it gets. It is important to dissipate the heat as quickly as possible. This results in increased reliability and longevity for the amplifier.

The amplifier module is mounted on a large heatsink, which is cooled by convection where cool air is drawn through its fins, carrying the heat away. In order for this convection cooling to work efficiently, it is important to provide adequate airspace behind the loudspeaker. When positioning the HD1521, we recommend leaving at least six inches of air space behind it.

In the unlikely event of the amplifier overheating, a

built-in thermal switch will activate, muting the signal and lighting the thermal LED. When the amplifier has cooled down to a safe operating temperature, the thermal switch resets itself, and the HD1521 resumes normal operation.

If the thermal switch activates frequently, try turning down the level control a notch or two on the mixing console (or the back of the HD1521) to avoid overheating the amplifier. Be aware that direct sunlight and/or hot stage lights may be the culprit of an amplifier overheating.

AC Power

Be sure the HD1521 is plugged into an outlet that is able to supply the correct voltage specified for your model. If the voltage should drop below 95% of the specified line voltage, the built-in amplifiers will no longer be able to supply rated power. (They will continue to operate down to 80% of the rated line voltage, but won't reach full power, resulting in lower headroom.)

Be sure the electrical service can supply enough amperage for all the components connected to it.

We recommend that a stiff (robust) supply of AC power be used because the amplifiers place high current demands on the AC line. The more power that is available on the line, the louder the speakers will play and the more peak output power will be available for a cleaner, punchier bass. A suspected problem of "poor bass performance" is often caused by a weak AC supply to the amplifiers.



Never remove the ground pin on the power cord or any other component of the HD1521. This is very dangerous.

Care and Maintenance

Your Mackie loudspeakers will provide many years of reliable service if you follow these guidelines:

- Avoid exposing the loudspeakers to moisture. If they are set up outdoors, be sure they are under cover if rain is expected.
- Avoid exposure to extreme cold (below freezing temperatures). If you must operate the loudspeakers in a cold environment, warm up the voice coils slowly by sending a low-level signal through them for about 15 minutes prior to high-power operation.
- Use a dry cloth to clean the cabinets. Only do this when the power is turned off. Avoid getting moisture into any of the openings of the cabinet, particularly where the drivers are located.

Appendix A: Service Information

If you think your Mackie product has a problem, please check out the following troubleshooting tips and do your best to confirm the problem. Visit the Support section of our website (www.mackie.com/support) where you will find lots of useful information such as FAQs and other documentation. You may find the answer to the problem without having to send your Mackie product away.

Troubleshooting

No power

- Is it plugged in? Make sure the AC outlet is live (check with a tester or lamp).
- Our next favorite question: Is the power switch on? If not, try turning it on.
- Is the power LED on the rear panel glowing green? If not, make sure the AC outlet is live. If so, refer to "No sound" below.
- The internal AC line fuse may be blown. This is not a user serviceable part. If you suspect the AC line fuse is blown, please see the "Repair" section next.

No sound

- Is the input level control for the input source turned all the way down? Verify that all the volume controls in the system are properly adjusted.
- Is the signal source working? Make sure the connecting cables are in good repair and securely connected at both ends. Make sure the output volume (gain) control on the mixing console is turned up sufficiently to drive the inputs of the speaker.
- Make sure the mixer does not have a Mute on or a Processor loop engaged. If you find something like this, make sure the volume/gain is turned down before disengaging the offending switch.
- Is the thermal indicator lit red on the rear panel? Make sure there is at least six inches of free space behind the HD1521.

Poor bass performance

- Check the polarity of the connections between

the mixer and the loudspeakers. You may have your positive and negative connections reversed at one end of one cable, causing one loudspeaker to be out-of-phase.

Poor sound

- Is it loud and distorted? Make sure that you're not overdriving a stage in the signal chain. Verify that all level controls are set properly.
- Is the input connector plugged completely into the jack? Be sure all connections are secure.

Noise

- Make sure all connections to the active loudspeakers are good and sound.
- Make sure none of the signal cables are routed near AC cables, power transformers, or other EMI-inducing devices.
- Is there a light dimmer or other SCR-based device on the same AC circuit as the HD1521? Use an AC line filter or plug the HD1521 into a different AC circuit.

Hum

- Try disconnecting the cable connected to the main input jack. If the noise disappears, it could be a "ground loop," rather than a problem with the HD1521. Try some of the following troubleshooting ideas:
- Use balanced connections throughout your system for the best noise rejection.
- Whenever possible, plug all the audio equipment's linecords into outlets which share a common ground. The distance between the outlets and the common ground should be as short as possible.

Repair

For warranty service, refer to the warranty information on page 15.

Non-warranty service for Mackie products is available at a factory-authorized service center. To locate the nearest service center, visit www.mackie.com, click "Support" and select "Locate a Service Center." Service for Mackie products living outside the United States can be obtained through local dealers or distributors.

If you do not have access to our website, you may call the Tech Support department at 1-800-898-3211, Monday-Friday, during normal business hours, Pacific Time, to explain the problem. Tech Support will tell you where the nearest factory-authorized service center is located in your area.

Appendix B: Connections

“XLR” Connectors

The HD1521 has one female XLR input that accepts a balanced line-level signal. When connecting a balanced signal, be sure it's wired per AES (Audio Engineering Society) standards:

XLR

Hot (+) Pin 2

Cold (–) Pin 3

Shield (Ground) Pin 1

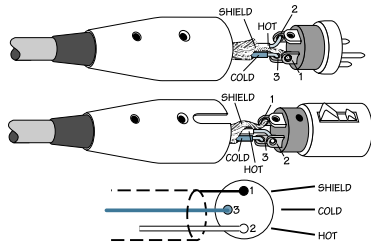

Balanced XLR Connectors

There is also a male XLR connector on the HD1521 labeled loop out. This is also wired according to the AES standards listed above.

The loop out connector allows you to connect several HD1521's. Simply plug the signal source (i.e., mixer output) into the input jack, and patch that speaker's loop out jack to the next speaker's input jack, and so on, daisy-chaining multiple speakers. See page 4 for a visual example of daisy-chaining.



There is a limit to how many you can daisy-chain together. A general rule is to maintain a load impedance ten times or more than the source impedance to prevent excessive loading on the source. For example, if your mixer has an output impedance of 120 ohms, then you can daisy chain up to nine HD1521s. This is a load of 1222 ohms (HD1521 input impedance=11 kohms; 9 of these in parallel=1222 ohms). Since microphones typically have a higher output impedance, you should limit daisy-chaining from a mic source to two HD1521s.

The loop out jack is wired straight from the main input connector — there is no electronic circuitry between — so the signal coming out of the loop out jack is exactly the same as the signal going in.

Appendix C: Technical Information

HD1521 Specifications

Acoustic Performance:

Frequency Response (-10 dB)	40 Hz-20 kHz
Frequency Response (-3 dB)	50 Hz-18 kHz
Horizontal Coverage (-6 dB)	80 degrees averaged 2 kHz to 10 kHz
Vertical Coverage (-6 dB)	50 degrees averaged 2 kHz to 10 kHz
Directivity Index (dB)	11.4 averaged 2 kHz to 10 kHz
Directivity Factor (Q)	14.0 averaged 2 kHz to 10 kHz
Max peak SPL (calculated) ¹	135 dB
Max peak SPL (measured) ²	125 dB
Crossover Point	1200 Hz

Equalization

Contour EQ	
Low Shelving	-3 dB to +3 dB 80 Hz, 6 dB / octave
Mid-Peaking	-3 dB to +3 dB 100 Hz to 8 kHz, Q=1.5
High Shelving	-3 dB to +3 dB 12 kHz, 6 dB / octave

High-Frequency Section

Voice Coil Diameter	1.75" / 44.5 mm
Horn Entry Diameter	1.0" / 25 mm
Diaphragm Material	Heat-treated titanium
Magnet Material	Ferrite

Low-Frequency Section

Woofers Diameter	15.0" / 381 mm
Voice Coil Diameter	3.0" / 76.2 mm
Diaphragm Material	Paper
Magnet Material	Neodymium

¹ Calculated from driver sensitivity and amplifier power.

² Measured with pink noise, free field at 1 meter, before limiting.

Power Amplifiers

Low Frequency Power Amplifier	
Rated Power	700 watts rms 1400 watts peak
Rated THD	< 0.03%
Design	Class D
High Frequency Power Amplifier	
Rated Power	100 watts rms 200 watts peak
Rated THD	< 0.03%
Design	Class D

Input/Output

Input Type	Female XLR balanced
Input Impedance	11 kohm balanced
Loop Out	Male XLR balanced

Line Input Power

US model	120 VAC, 60 Hz
Recommended Service	9 amps
European model	230 VAC, 50 Hz
Recommended Service	5 amps
AC Connector	3-pin IEC 250 VAC

Safety Features

Input Protection:	RMS limiting, power supply and amplifier thermal protection
Display LEDs:	Power ON, EQ ON, Sig/Limit, Thermal protection, Front Power ON

Construction Features

Basic Design	Trapezoidal, 20 degree included angle
Cabinet	15 mm exterior grade premium birch plywood
Finish	High durability black paint
Handles	One on each side
Grille	Powder-coated galvanized steel
Fly Points	Twelve M10 x 1.5 mm

Physical Properties

Height	30.00 in / 762 mm
Front Width	18.25 in / 463.5 mm
Rear Width	11.82 in / 300.2 mm
Depth	18.81 in / 477.8 mm
Weight	80 lb / 36 kg

Mounting Methods

Floor mount, pole mount, or fly via 12 integrated M10 mounting points (using M10 x 1.5 x 37 mm forged shoulder eyebolts). See page 8 for more information.

Disclaimer

Since we are always striving to make our products better by incorporating new and improved materials, components, and manufacturing methods, we reserve the right to change these specifications at any time without notice.

“Mackie” and the “Running Man” figure are registered trademarks of LOUD Technologies Inc.

All other brand names mentioned are trademarks or registered trademarks of their respective holders, and are hereby acknowledged.

©2009 LOUD Technologies Inc.
All Rights Reserved.

HD1521 Block Diagram

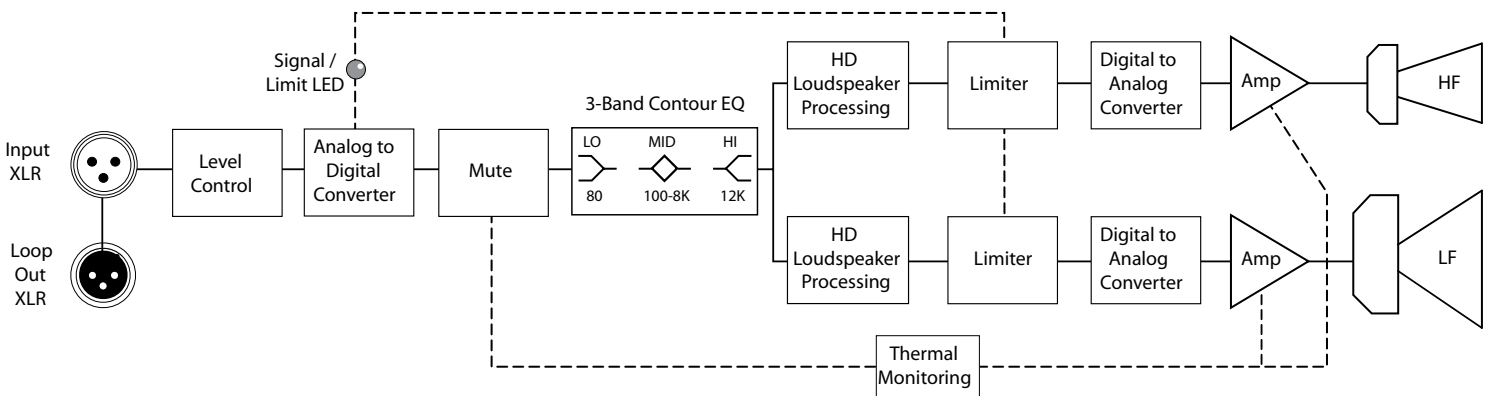

 **Correct disposal of this product.** This symbol indicates that this product should not be disposed of with your household waste, according to the WEEE Directive (2002/96/EC) and your national law. This product should be handed over to an authorized collection site for recycling waste electrical and electronic equipment (EEE). Improper handling of this type of waste could have a possible negative impact on the environment and human health due to potentially hazardous substances that are generally associated with EEE. At the same time, your cooperation in the correct disposal of this product will contribute to the effective usage of natural resources. For more information about where you can drop off your waste equipment for recycling, please contact your local city office, waste authority, or your household waste disposal service.

HD1521 Frequency Response On-Axis

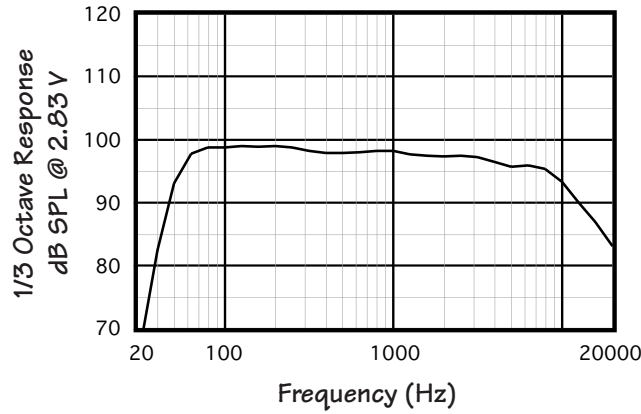

HD1521 Beamwidth vs. Frequency

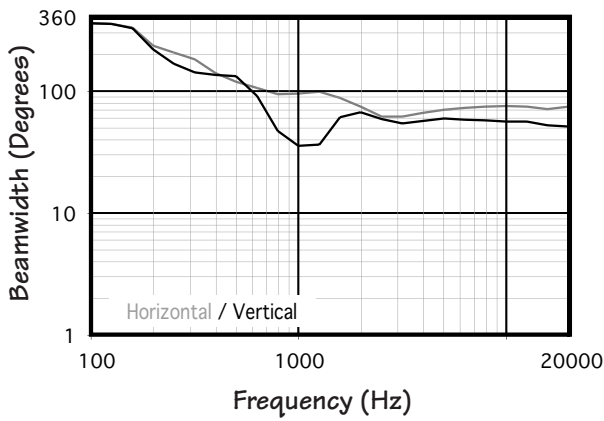

HD1521 Directivity vs. Frequency

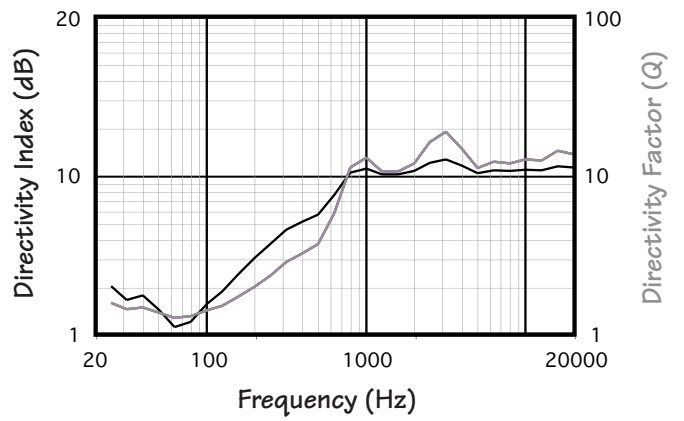

HD1521 Dimensions

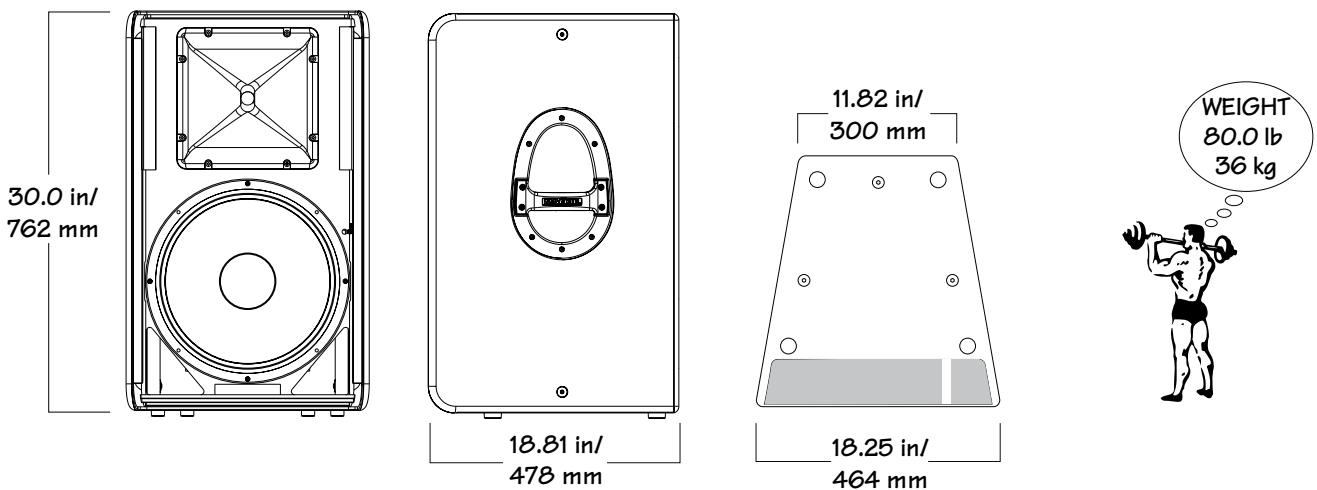

Mackie Limited Warranty

Please keep your sales receipt in a safe place.

This Limited Product Warranty ("Product Warranty") is provided by LOUD Technologies Inc. ("LOUD") and is applicable to products purchased in the United States or Canada through a LOUD-authorized reseller or dealer. The Product Warranty will not extend to anyone other than the original purchaser of the product (hereinafter, "Customer," "you" or "your").

For products purchased outside the U.S. or Canada, please visit www.mackie.com/warranty to find contact information for your local distributor, and information on any warranty coverage provided by the distributor in your local market.

LOUD warrants to Customer that the product will be free from defects in materials and workmanship under normal use during the Warranty Period. If the product fails to conform to the warranty then LOUD or its authorized service representative will at its option, either repair or replace any such nonconforming product, provided that Customer gives notice of the noncompliance within the Warranty Period to the Company at: www.mackie.com/support or by calling LOUD technical support at 1.800.898.3211 (toll-free in the U.S. and Canada) during normal business hours Pacific Time, excluding weekends or LOUD holidays. Please retain the original dated sales receipt as evidence of the date of purchase. You will need it to obtain any warranty service.

For full terms and conditions, as well as the specific duration of the Warranty for this product, please visit www.mackie.com/warranty.

The Product Warranty, together with your invoice or receipt, and the terms and conditions located at www.mackie.com/warranty constitutes the entire agreement, and supersedes any and all prior agreements between LOUD and Customer related to the subject matter hereof. No amendment, modification or waiver of any of the provisions of this Product Warranty will be valid unless set forth in a written instrument signed by the party to be bound thereby.

Need help with your new powered loudspeaker?

- Visit www.mackie.com and click Support to find: FAQs, manuals, and addendums.
- Email us at: techmail@mackie.com.
- Telephone 1-800-898-3211 to speak with one of our splendid technical support chaps (Monday through Friday, normal business hours, PST).

MACKIE®

16220 Wood-Red Road NE • Woodinville, WA 98072 • USA

United States and Canada: 800.898.3211

Europe, Asia, Central and South America: 425.487.4333

Middle East and Africa: 31.20.654.4000

Fax: 425.487.4337 • www.mackie.com

E-mail: sales@mackie.com

Free Manuals Download Website

<http://myh66.com>

<http://usermanuals.us>

<http://www.somanuals.com>

<http://www.4manuals.cc>

<http://www.manual-lib.com>

<http://www.404manual.com>

<http://www.luxmanual.com>

<http://aubethermostatmanual.com>

Golf course search by state

<http://golfingnear.com>

Email search by domain

<http://emailbydomain.com>

Auto manuals search

<http://auto.somanuals.com>

TV manuals search

<http://tv.somanuals.com>