

SWA1801

■ The SWA1801 is an 18-inch high output, active subwoofer system. It features a newly designed high-precision 18-inch transducer combined with application-specific amplifier technology. The system is composed of a single, compact subwoofer cabinet with built-in control and amplifier electronics.

■ The transducer used in the SWA1801 system features a precision 4-inch voice coil that offers extreme power handling capabilities. The magnetic assembly used features advancements in coil venting, composite polyimide former construction, and structural cooling that provide lower temperature rise and substantially improved power compression characteristics.

■ The amplifier found in the SWA1801 cabinet is an example of application-specific amplifier design that can be exercised when designing active speaker systems. The system uses a proprietary high-efficiency, high-current amplifier designed to provide high current levels at all levels of operation. Having access to high current levels, no matter what the power output, is absolutely critical in achieving precise, total control of the woofer mass. This control is responsible for lowering audible distortion artifacts and providing aggressive attack through the operating band pass of the system. The amplifier, which is mounted on a large, finned aluminum heat sink, is rated at 800 watts rms continuous output.

■ The SWA1801 features a sophisticated on board control system, allowing for flexible integration with active or passive full range or mid/high speaker systems. The input panel accepts a line-level input signal and has LOOP OUT connectors for signal routing to other devices. It also has HIGH PASS out connectors for connection to active full range speakers or amplifiers powering passive full range speakers. All signal routing is through XLR connectors in L+R stereo or mono. There is a phase selection switch and a recessed level control. The system features thermal protection for the power supply and amplifier and also incorporates rms limiting protection for the amplifier stage that limits the amount of long term power delivered to the transducer.

■ The cabinet is constructed using 18 mm thick multi-layered birch plywood and finished in black splatter paint. There is one handle on each side for efficient loading and transport as well as a top, female pole mount fixture.

RELATED PRODUCTS

SRM350/SRM450/SR1530/SA1521/SA1232 Active Loudspeakers, SWA1501 Active Subwoofer, 1202-VLZ PRO 12-Channel Mic/Line Mixer, 1402-VLZ PRO 14-Channel Mic/Line Mixer, 1604-VLZ PRO and 1642-VLZ PRO 16-Channel Mic/Line Mixers.

Active Subwoofer System



Features

- Active, high-output 18-inch subwoofer system with 4-inch voice coil
- High-efficiency, high-current 800 watt rms continuous output amplifier
- High output 135 dB of peak SPL
- Response down to 35Hz (-10 dB point)
- Can be used with active or passive speaker systems
- Built-in crossover network with stereo or mono high-pass outputs
- Recessed level control, center detent rotating knob (-15 to +5 dB)
- Recessed phase switch (0°-180°)
- Compact, portable enclosure
- Small footprint allows for unobtrusive, strategic placement
- Baltic birch wood construction, built-in pole mount
- Correctly weight-balanced enclosure
- Two comfortable side handles for easy carrying and setup

Applications

- Live Sound/Music Reinforcement
- High-Level AV Playback
- Small to Medium-Sized Portable PA Systems
- Corporate Events
- Night Clubs
- Houses of Worship

SWA1801 Active Subwoofer System

SWA1801 Technical Specifications

System Acoustic

Acoustic Performance	
-3 dB Response:	45 Hz–120 Hz
-10 dB Response:	35 Hz–120 Hz
Max SPL Long-term:	129 dB
Max SPL Peak:	135 dB
Crossover Point:	120 Hz

Input/Output

Input:	Stereo bal./unbal. female XLR
Input Impedance:	50 kΩ
Loop-Through:	Stereo bal./unbal. male XLR
High Pass Output:	Stereo bal./unbal. male XLR
Level Control:	Recessed rotating knob, center detent (-15 to +5 dB)
Phase Control (0° – 180°)	Recessed sliding switch

Amplifier

Total Amplifier Power:	800 W continuous* 1000 W peak
Type:	High-efficiency, high-current Class G hybrid
Rated THD:	.03%

*Rated power is continuous rms wattage into transducer's rated impedance @ 100 Hz

Transducer

Number of Drivers:	1
Woofer Size:	18" (457 mm)
Voice Coil Diameter:	4" (102 mm)
Diaphragm Material:	Epoxy-reinforced cellulose
Magnet Type:	Ferrite

Line Input Power

US:	120 VAC, 60 Hz
Recommended Amperage Service:	15 A
Europe:	230 VAC, 50 Hz
Recommended Amperage Service:	8 A
AC Connector:	3-pin IEC 250 VAC, 16 A male

Control System Function

Electronic Crossover
Equalization

Safety Features

Protection:	Low-frequency dynamic bass protection, rms limiting, power supply and amplifier thermal protection
Display:	Signal present, limit, power on, and thermal (cool down auto-reset) LEDs

Physical

Basic Design:	Compact/rectangular
Material:	.75" (18 mm) thick 13-ply baltic birch plywood
Finish:	High-quality splatter black paint
Handles:	One on each side
Pole Mount:	Metal pole mount located on top of cabinet
Moving Wheels:	4 each (2 swivel with bushing-mounted ball bearings)
Dimensions (HxWxD):	28.5" x 23.5" x 23.5" (724 mm x 597 mm x 597 mm)
Weight:	132 lbs/60 kg

SWA1801 Dimensions

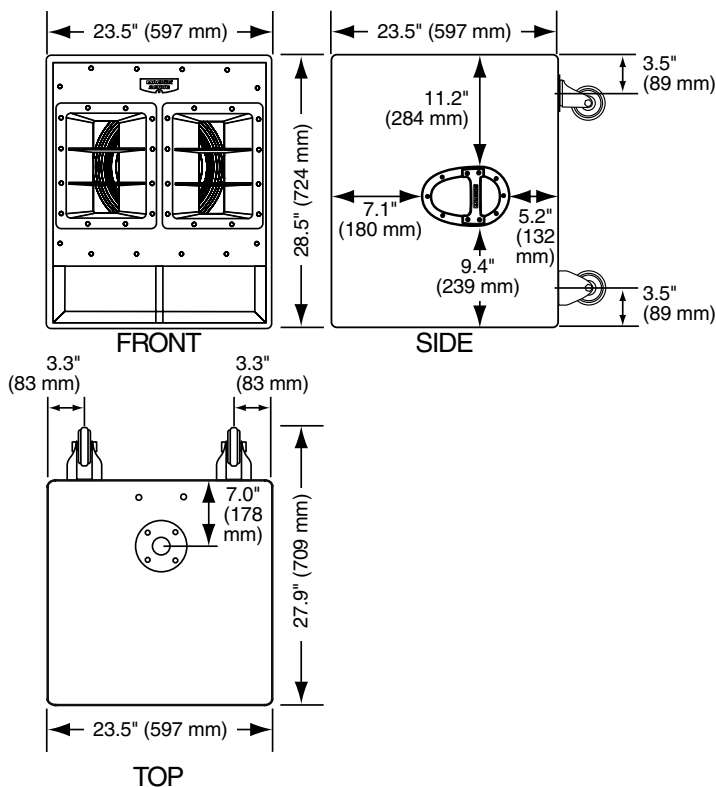

SWA1801 Active Subwoofer System

SPEAKER

SWA1801

SWA1801 On-Axis Frequency Response (With Second and Third Harmonic Components)

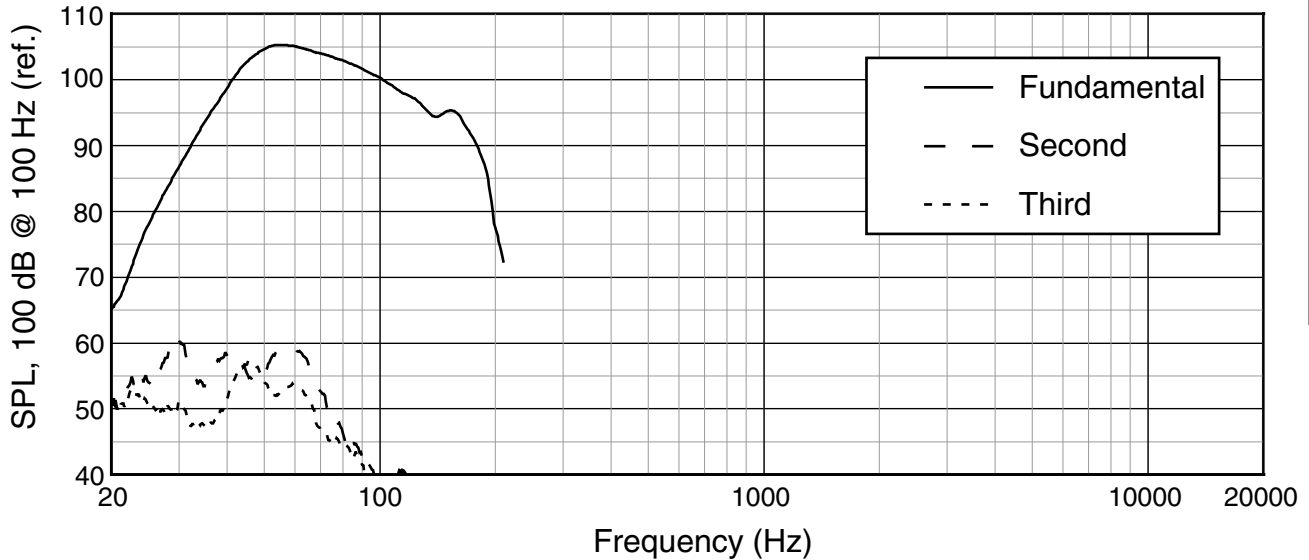

SWA1801 Rear Panel Connector Plate

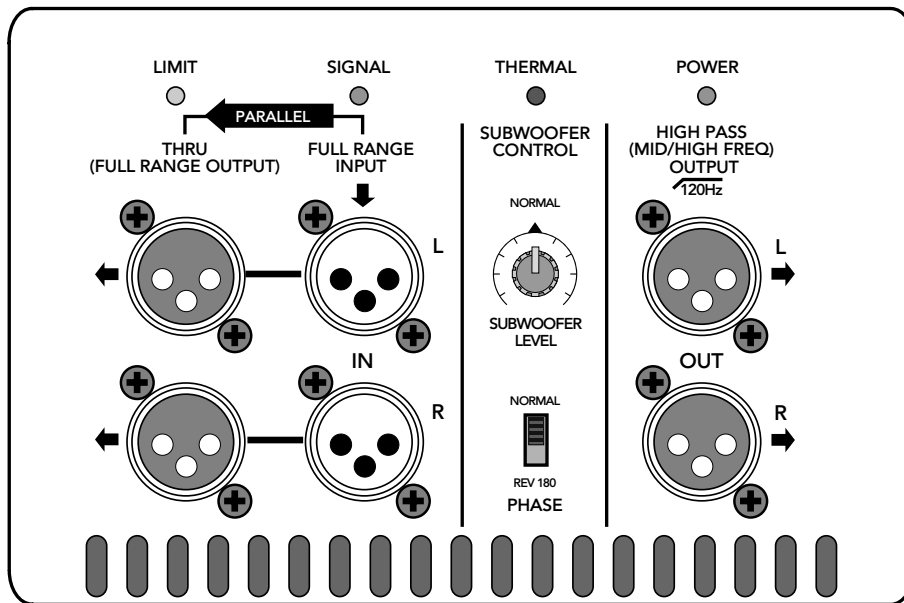

SWA1801 Active Subwoofer System

Architects' and Engineers' Specifications

The active subwoofer loudspeaker system shall incorporate one 18-inch low-frequency (LF) transducer mounted within a vented enclosure and tuned for optimum low-frequency response. System frequency response shall vary no more than ± 3 dB from 45 Hz to 120 Hz measured on axis. The loudspeaker shall incorporate a low-frequency amplifier system capable of delivering 800 watts rms over a frequency range of 30 Hz to 150 Hz. The system shall provide 129 dB of continuous output and 135 dB of peak output. The amplifier system shall be mounted on an aluminum heat sink, which shall be mounted on the rear of the enclosure, and shall be convection cooled.

The rear-mounted amplifier assembly shall comprise separate signal and AC power panels separated by a large aluminum heat sink. The signal input panel shall contain two input and two loop-through XLR connectors, two high-pass output XLR connectors, a volume level control, a phase switch, and four status LEDs for Power ON, Signal Present, Limit, and Thermal functions. The system shall accept a standard line-level signal via the XLR input connectors. The power switch and IEC AC connector shall be located on the power panel.

Thermal protection shall be provided by a heat sink-mounted thermal sensor, which monitors the heat sink temperature and triggers the thermal protection circuit should the temperature exceed 140° F (60° C). The Thermal LED shall light and the input signal shall be muted until the heat sink cools to a safe operating level, at which point the thermal protection circuit auto-resets and normal operation resumes.

Overload protection shall be provided by a limiter circuit, which monitors the amplifier output and reduces the input level to the amplifier should the amplifier output begin to clip.

The enclosure shall have a rectangular shape and shall incorporate two side handles, one on each side, and a top-mounted pole receptacle. The enclosure shall be constructed of multi-ply wood.

The active subwoofer loudspeaker system shall be the Mackie SWA1801.

Electronic files for this product available at:
www.mackie.com

This Specification Sheet	SWA1801_SS.PDF
Owner/Operator's Manual	SWA1801_OM.PDF

MACKIE®

www.mackie.com

16220 Wood-Red Road NE, Woodinville, WA 98072 USA
800.898.3211, fax 425.487.4337, sales@mackie.com

UK +44.1268.570.808, fax +44.1268.570.809, uk@mackie.com

LOUD Technologies continually engages in research related to product improvement. New material, production methods, and design refinements are introduced into existing products without notice as a routine expression of that philosophy. For this reason, any current LOUD Technologies product may differ in some respect from its published description, but will always equal or exceed the original design specifications unless otherwise stated. ©1999-2004 LOUD Technologies Inc. All rights reserved.

Part No. 0003348 Rev C 09/05

Free Manuals Download Website

<http://myh66.com>

<http://usermanuals.us>

<http://www.somanuals.com>

<http://www.4manuals.cc>

<http://www.manual-lib.com>

<http://www.404manual.com>

<http://www.luxmanual.com>

<http://aubethermostatmanual.com>

Golf course search by state

<http://golfingnear.com>

Email search by domain

<http://emailbydomain.com>

Auto manuals search

<http://auto.somanuals.com>

TV manuals search

<http://tv.somanuals.com>