

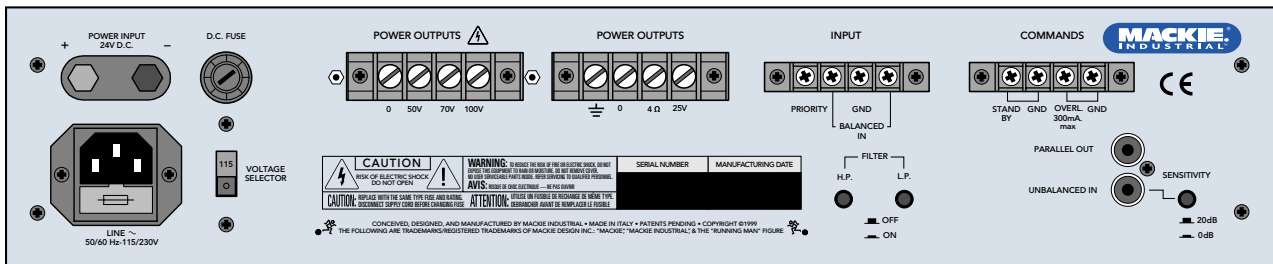

UP4000 SERIES POWER AMPLIFIER

UP4061 • UP4121 • UP4161

INSTRUCTION MANUAL

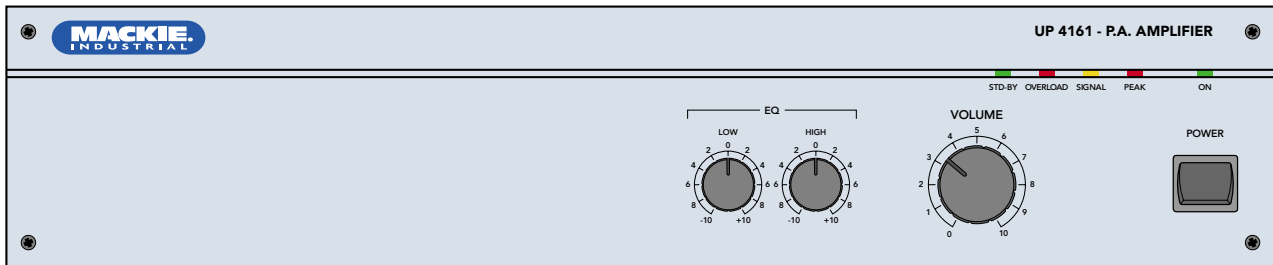

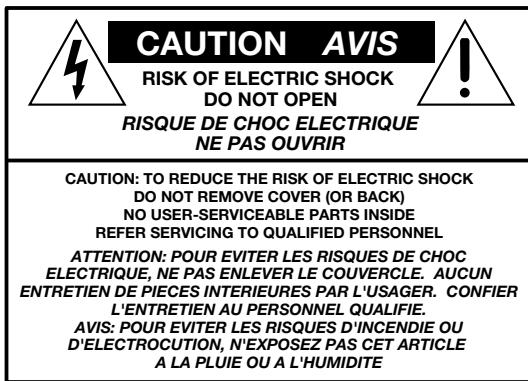

The lightning flash with arrowhead symbol within an equilateral triangle is intended to alert the user to the presence of uninsulated "dangerous voltage" within the product's enclosure, that may be of sufficient magnitude to constitute a risk of electric shock to persons.

Le symbole éclair avec point de flèche à l'intérieur d'un triangle équilatéral est utilisé pour alerter l'utilisateur de la présence à l'intérieur du coffret de "voltage dangereux" non isolé d'ampleur suffisante pour constituer un risque d'électrocution.



The exclamation point within an equilateral triangle is intended to alert the user of the presence of important operating and maintenance (servicing) instructions in the literature accompanying the appliance.

Le point d'exclamation à l'intérieur d'un triangle équilatéral est employé pour alerter les utilisateurs de la présence d'instructions importantes pour le fonctionnement et l'entretien (service) dans le livret d'instruction accompagnant l'appareil.

1. SAFETY INSTRUCTIONS

- 1. Read Instructions** — Read all the safety and operation instructions before operating the UP4000.
- 2. Retain Instructions** — The safety and operating instructions should be kept for future reference.
- 3. Heed Warnings** — Follow all warnings on the UP4000 and in these operating instructions.
- 4. Follow Instructions** — Follow all operating and other instructions.
- 5. Water and Moisture** — Do not use the UP4000 near water — for example, near a bathtub, washbowl, kitchen sink, laundry tub, in a wet basement, near a swimming pool, etc.
- 6. Ventilation** — This UP4000 should be situated so that its location or position does not interfere with its proper ventilation. For example, it should not be situated on a bed, sofa, rug, or similar surface that may block any ventilation openings, or placed in a built-in installation such as a bookcase or cabinet that may impede the flow of air through ventilation openings.
- 7. Heat** — Locate the UP4000 away from heat sources such as radiators, or other devices which produce heat.

8. Power Sources — Connect the UP4000 to a power supply only of the type described in these operation instructions or as marked on the rear panel.

9. Power Cord Protection — Route power supply cords so that they are not likely to be walked upon or pinched by items placed upon or against them, paying particular attention to cords at plugs, convenience receptacles, and the point where they exit the UP4000.

10. Object and Liquid Entry — Do not drop objects into or spill liquids into the inside of the UP4000.

11. Damage Requiring Service — The UP4000 should be serviced only by qualified service personnel when:

- The power-supply cord or the plug has been damaged; or
- Objects have fallen, or liquid has spilled into the UP4000; or
- The UP4000 has been exposed to rain; or
- The UP4000 does not appear to operate normally or exhibits a marked change in performance; or
- The UP4000 has been dropped, or its chassis damaged.

12. Servicing — The user should not attempt to service the UP4000 beyond those means described in this operating manual. All other servicing should be referred to the Mackie Service Department.

13. To prevent electric shock, do not use this polarized plug with an extension cord, receptacle or other outlet unless the blades can be fully inserted to prevent blade exposure.

Pour prévenir les chocs électriques ne pas utiliser cette fiche polarisée avec un prolongateur, un prise de courant ou une autre sortie de courant, sauf si les lames peuvent être insérées à fond sans laisser aucune partie à découvert.

14. Grounding or Polarization — Precautions should be taken so that the grounding or polarization means of the UP4000 is not defeated.

15. This apparatus does not exceed the Class A/Class B (whichever is applicable) limits for radio noise emissions from digital apparatus as set out in the radio interference regulations of the Canadian Department of Communications.

ATTENTION — *Le présent appareil numérique n'émet pas de bruits radioélectriques dépassant les limites applicables aux appareils numériques de class A/de class B (selon le cas) prescrites dans le règlement sur le brouillage radioélectrique édicté par les ministere des communications du Canada.*

WARNING — To reduce the risk of fire or electric shock, do not expose this appliance to rain or moisture.

TABLE OF CONTENTS

1. SAFETY INSTRUCTIONS	2	4. OPERATION	9
2. INTRODUCTION	3	USING THE BALANCED INPUT	9
KEY FEATURES	3	USING THE UNBALANCED INPUT	9
FRONT PANEL FEATURES	4	USING THE PARALLEL OUT	9
REAR PANEL FEATURES	4	COMMANDS STANDBY	9
3. INSTALLATION	6	POWER OUTPUTS	9
APPLICATION DIAGRAM	6	POWER INPUT 24V D.C.	9
CONNECTIONS	7	5. SPECIFICATIONS	10
INTERNAL SETTINGS	8	UP4000 SERIES BLOCK DIAGRAM	10
AC POWER CONSIDERATIONS	8	UP4000 SERIES SPECIFICATIONS	10
THERMAL CONSIDERATIONS	8	6. SERVICE INFORMATION	11

2. INTRODUCTION

The UP4000 Series Power Amplifiers are designed for continuous duty in speech, music, paging, and sound reinforcement applications in churches, schools, offices, and other venues demanding high performance, flexible features, and rugged dependability.

Two discrete inputs with priority are provided. The main program input is actively balanced and terminated to a barrier strip connection on the rear panel. The second input is unbalanced and terminated to a single RCA connector. A contact closure will give priority to the balanced input by muting the unbalanced input. The unbalanced input features a parallel output and 0 dB/20 dB sensitivity switch.

Output modes include 4Ω constant impedance and 25V, 50V, 70V, and 100V constant voltage. The smart output stage is fully protected against permanent damage caused by overloading, shorts, and extreme temperatures. Activation of the overload protection circuit turns on 18 VDC (300mA) power at a barrier connector on the rear panel, which may be used to drive a relay or indicating LED. The UP4000 Series will operate on either 115 VAC or 230 VAC, 50/60Hz, as determined by the Voltage Selector switch, and supplied by a detachable IEC power cord. Insulated terminals to connect a backup 24 VDC battery are provided on the rear panel. Switchover to DC is automatic. A programmable stand-by mode allows the amplifier to be turned on remotely with a contact closure.

The front panel provides a Master volume control, and Low and High EQ controls. The control knobs can be removed for security, and their recessed shafts covered with the supplied inserts. LEDs indicate power, stand-by mode, signal present at the output, peak, and output overload. 12 dB/octave Low and High shelving equalization with up to 12 dB of boost or cut at 100Hz and 10kHz can be applied to the output signal.

Accessories include a rack mounting kit.

KEY FEATURES

- Balanced and Unbalanced Inputs
- Balanced Input Priority Function
- Unbalanced Line-Level Output
- Convection Cooled Power Amplifier
 - UP4061: 60 Watts RMS
 - UP4121: 120 Watts RMS
 - UP4161: 160 Watts RMS
- 4Ω Constant-Impedance Output
- 25V, 50V, 70V, and 100V Constant-Voltage Outputs
- High-Pass and Low-Pass Filters
- 2 RU Rack-Mounting Kit
- Automatic 24 VDC Backup Power Input



FRONT PANEL FEATURES

- 1 **LOW EQ** is a shelving filter that provides 12 dB of boost and cut below 100Hz.
- 2 **HIGH EQ** is a shelving filter that provides 12 dB of boost and cut above 10kHz.
- 3 **VOLUME** is a master volume control used to adjust the overall volume of the signal at the **POWER OUTPUTS**.
- 4 Use the **POWER** switch to turn the UP4000 Series on and off.
- 5 The **STD-BY** indicator lights when the amplifier is in standby mode.
Note: Standby mode is disabled by default. An internal jumper (J1 on the input board) must be changed to enable standby mode. See "Internal Settings" on page 8.
- 6 The **OVERLOAD** indicator lights when the amplifier is operating in overload, a condition generally caused by a problem on the speaker line. When the amplifier is switched on, the **OVERLOAD** light comes on for a few seconds. This is normal and does not indicate a problem.
- 7 The **SIGNAL** indicator lights when a signal is present at the **POWER OUTPUTS**.
- 8 The **PEAK** indicator lights when the output signal is approaching clipping.
- 9 The **ON** indicator lights when the UP4000 is turned on and ready for operation.

REAR PANEL FEATURES

- 10 **POWER INPUT** provides a means to connect an external 24 VDC power supply or battery as an alternative or backup power source. The UP4000 Series seamlessly switches to the backup supply if there's an AC power loss. When both AC power and 24 VDC power are connected, the DC power is switched off.

Note: The unit is not equipped with battery charging capability.

- 11 The **D.C. FUSE** protects the DC power input to the amplifier circuit. Replace with the same type fuse only.

- 12 **POWER OUTPUTS** are screw-terminal connections for connecting speakers to the 4-ohm, 25V, 50V, 70V, or 100V outputs.

WARNING: To prevent the risk of electric shock, never touch the bare wires coming from the output terminals of the amplifier when it is switched on. When all connections have been made, insulate the output terminals of the amplifier using the protective cover provided.

Constant-Impedance Output

The total impedance of the speakers and cable connected to the "4Ω" constant-impedance output should be 4 ohms. Connect the "4Ω" terminal to the "+" (HIGH) speaker terminal, and the "0" terminal to the "-" (LOW) speaker terminal.

Constant-Voltage Output

In a constant-voltage system, each speaker must be equipped with a line transformer having an input voltage equal to that of the line (e.g., 25V, 50V, 70V, or 100V). Typically, these line transformers have selectable power taps (i.e., 2.5W, 5W, 10W) for connecting to the constant-voltage line. **CAUTION:** The sum of the wattage values of the speakers must not exceed the output power of the amplifier.

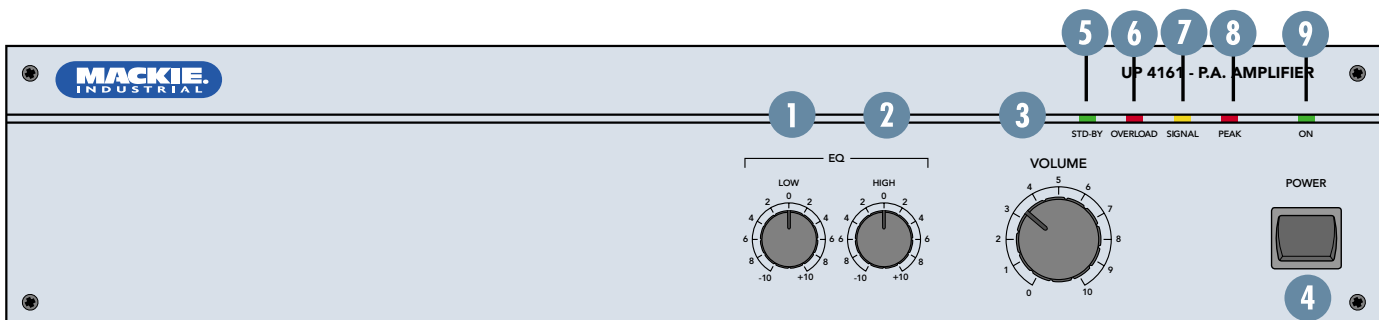

Connect the appropriate **POWER OUTPUT** voltage terminal to the "+" (HIGH) leg and the "0" terminal to the "-" (LOW) leg of the distributed speaker system.

13 The ground (\equiv) terminal is internally connected to the chassis and safety ground on the AC linecord.

14 The **PRIORITY** terminal activates the priority function for the **BALANCED IN** by using an external normally-open switch to short-circuit the **PRIORITY** terminal to the **GND** 15 (ground) terminal. When the **PRIORITY** function is enabled, the **UNBALANCED IN** is muted (no signal from the **UNBALANCED IN** is transmitted to the outputs).

15 This **GND** terminal is the common connection point for **BALANCED IN** and **PRIORITY**.

16 The **BALANCED IN** terminals are the main input for the amplifier and accept a balanced line-level signal (0 dBu nominal). This input has a priority function, which mutes the **UNBALANCED IN** signal when the **PRIORITY** terminal is shorted to **GND**.

17 The **STAND BY** terminal is used to turn on the amplifier with a remote switch.

Note: Standby mode must first be activated by moving a jumper (J1) on the input board (standby mode is disabled by default). See "Internal Settings" on page 8.

When the **POWER** switch is turned on, the amplifier goes into standby mode. In this state, the amplifier is on but signal is not allowed to pass. Shorting the **STAND BY** terminal to the **GND** 18 terminal with an external switch causes the amplifier to become fully operational.

18 The **STANDBY GND** terminal on the **COMMANDS** terminal strip is the common connection point for **STAND BY**.

19 The **OVERL. 300mA** terminal is active whenever the amplifier's overload protection circuit is activated. This provides 18 VDC with a maximum output capacity of 300mA for driving an auxiliary relay or indicating LED.

20 The **OVERL. GND** terminal on the **COMMANDS** terminal strip is the common connection point for **OVERL. 300mA**.

21 AC Protection Fuse protects the power supply and amplifier circuitry. Replace only with same type fuse.

22 Connect the supplied AC linecord to the IEC AC Socket. The AC line fuse is contained in the socket, behind the cover located at the bottom of the socket. Replace only with same type fuse.

23 The **VOLTAGE SELECTOR** switch is used to select the AC supply voltage for the amplifier. Move the switch so the AC line voltage used appears on the switch (DOWN for 115V, UP for 230V).

24 The **H.P.** switch activates a high-pass filter on the balanced and unbalanced inputs, which attenuates frequencies below 300Hz at 12 dB/octave.

25 The **L.P.** switch activates a low-pass filter on the balanced and unbalanced inputs, which attenuates frequencies above 7kHz at 12 dB/octave.

26 **UNBALANCED IN** is an RCA jack that can be used instead of the **BALANCED IN**, or both can be used with the **PRIORITY** function, which gives the **BALANCED IN** priority over the **UNBALANCED IN**.

27 **PARALLEL OUT** is an RCA jack that is in parallel with the **UNBALANCED IN** jack for connecting to the input of another power amplifier.

28 The **SENSITIVITY** switch adjusts the input sensitivity of the **UNBALANCED IN** from 0 dB (typical line-level signals) to 20 dB (for low-level signals).

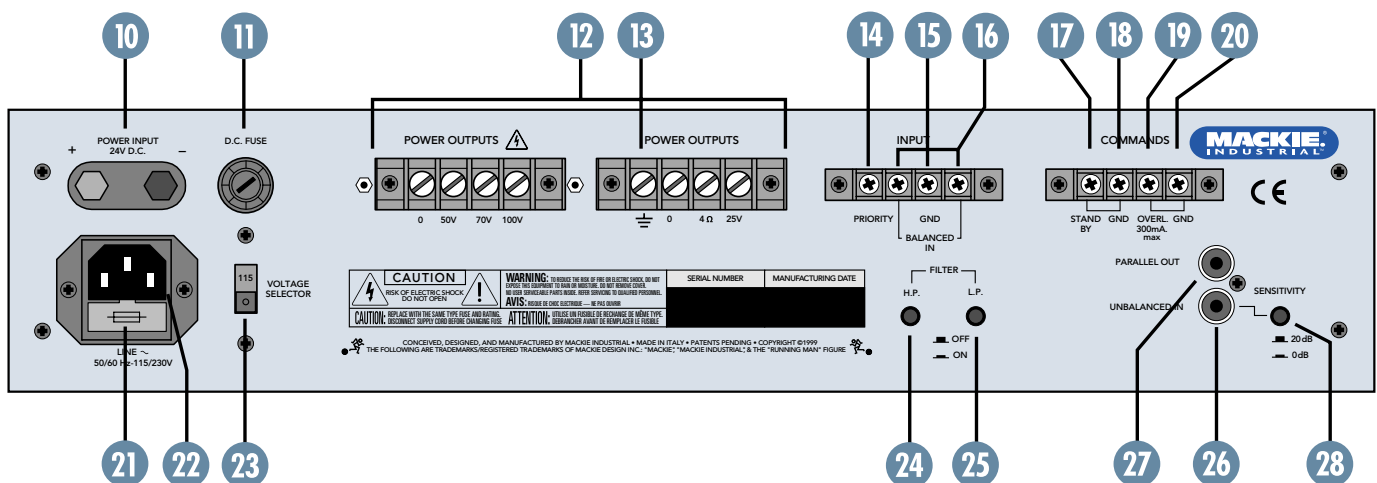

3. INSTALLATION APPLICATION DIAGRAM

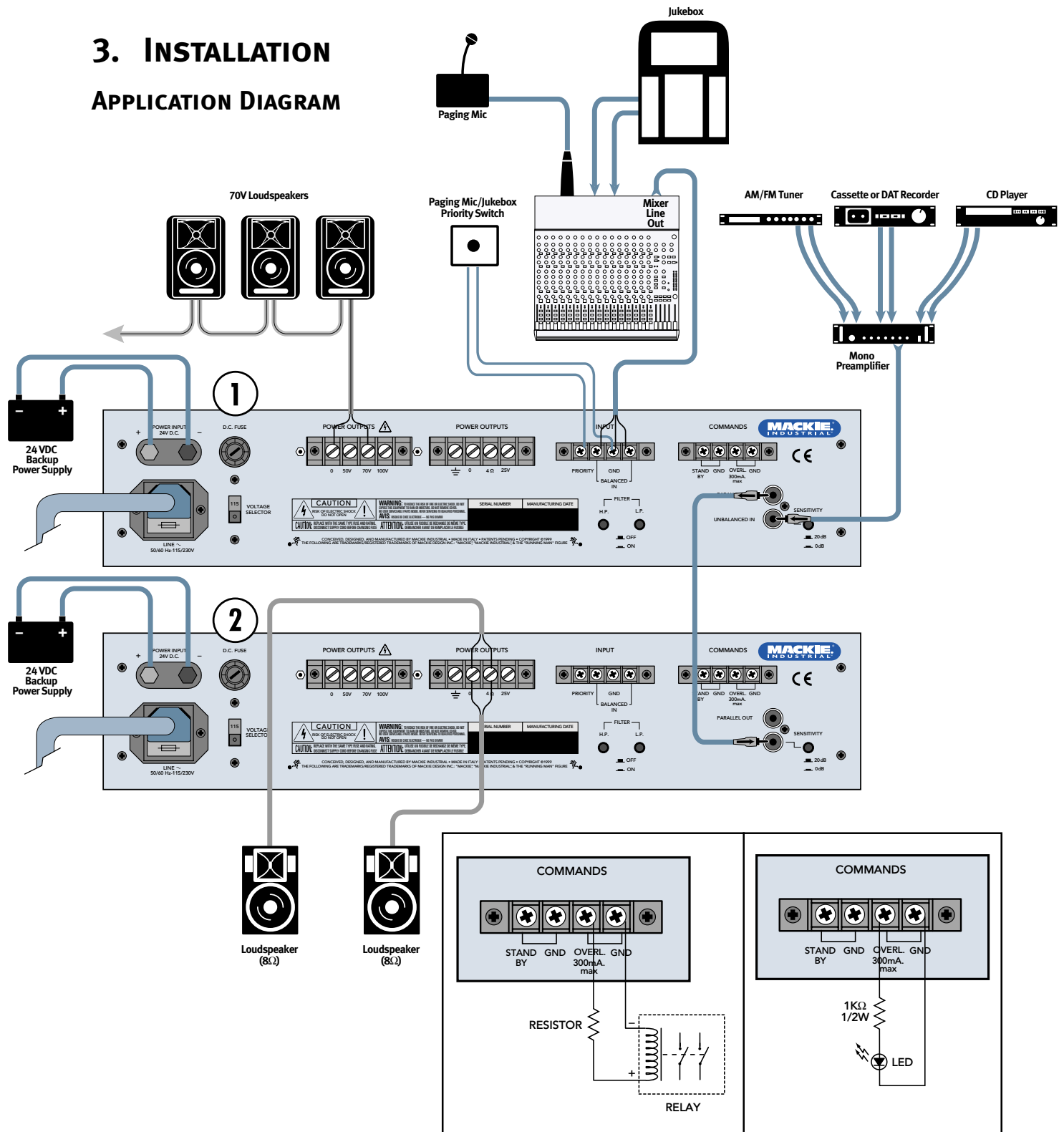

Note: This illustration demonstrates a typical application using a pair of UP4000 Series Power Amplifiers. A paging microphone and a jukebox are connected to the Balanced Input of Amp 1 via the Mixer, and the Input priority function can be switch-activated to give the paging mic and jukebox priority over the signal source connected to the Unbalanced Input. A preamplifier is connected to the Unbalanced Input, with source selections for an AM/FM Tuner, Cassette or DAT Recorder, and CD Player. The Parallel Out is connected to the Unbalanced Input on a second UP4000 Series. 70V constant-voltage speakers are connected to the 70V tap on Amp 1, and a pair of 8-ohm speakers (connected in parallel for a total impedance of 4 ohms) are connected to the 4Ω tap on Amp 2.

CONNECTIONS

CONNECTING THE INPUT

The Input has a balanced screw terminal connector that accepts a line-level signal. The screw terminals should be connected as shown in the following figure:

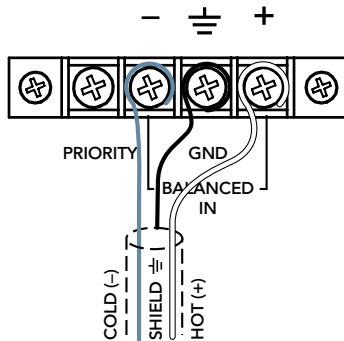

INPUT Terminal Strip: Balanced Connection

Strip the wire back about 1/2" inch, loosen the screw enough to loop the wire around the shaft of the screw (clockwise), and tighten down the screw with either a slot-head or phillips-head screwdriver.

Use high-quality, three-conductor shielded cable for balanced connections. The better the shield, the better the audio signal is protected from induced EMI and RFI.

If connecting an unbalanced line-level signal to the Input, wire the connections as shown in the following figure:

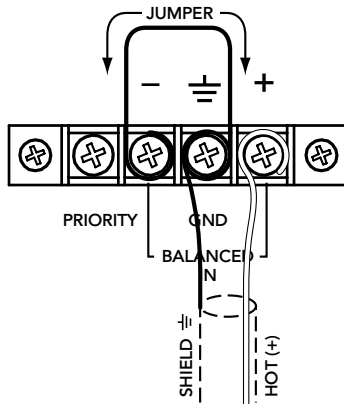

INPUT Terminal Strip: Unbalanced Connection

CONNECTING THE UNBALANCED IN

The UNBALANCED IN uses an RCA-type connector. It accepts a line-level signal (-10 dBV) with the SENSITIVITY switch in the 0 dB position (pushed IN). When connecting a low-level signal, push the SENSITIVITY switch OUT (20 dB position). Use high-quality, two-conductor shielded cable to make these connections.

CONNECTING THE SPEAKERS

The speaker output connectors are screw terminals. Use 16 or 18 gauge wire for connecting the amplifier outputs to the speakers. Strip the wire back about 1/2" inch, loosen the screw enough to loop the wire around the shaft of the screw (clockwise), and tighten down the screw with a slot-head screwdriver.

If using a 4-ohm speaker, connect the 4Ω output terminal to the "+" terminal on the speaker, and connect the "0" output terminal to the "-" terminal on the speaker.

If using a constant-voltage distributed speaker system, connect either the 25V, 50V, 70V, or 100V output terminal to the "+" side of the speaker system, and connect the "0" output terminal to the "-" side of the speaker system. Make sure that the taps on the speakers add up to no more than the rated power for the UP4000 Series Amplifier being used.



CAUTION: To prevent the risk of electric shock, never touch the bare wires coming from the **OUTPUT TERMINALS** of the amplifier when it is switched on.

When the connections have been made, insulate the 50V, 70V, and 100V terminals of the amplifier using the protective cover supplied.

CONNECTING THE POWER INPUT 24V.D.C.

Connect a 24 VDC power supply to these spring terminals as an alternate method to power the UP4000 Series. To minimize the voltage drop across the wire and prevent overheating, use at least 16 AWG wire for the UP4061, and 14 AWG wire for the UP4121 and UP4161.

INTERNAL SETTINGS

There is one setting that can be changed inside the UP4000 Series Amplifier. This setting should be made prior to installation.



CAUTION: These servicing instructions are for use by qualified personnel only. To avoid electric shock, do not perform any servicing other than that contained in the Operating Instructions unless you are qualified to do so. Refer all servicing to qualified service personnel. *Make sure the power is off and the power cord disconnected* before removing the top cover to gain access to the inside of the UP4000 Series.

STANDBY MODE

Jumper J1 on the input board allows you to enable the Standby function. Standby mode is disabled by default. You must change jumper J1 on the input board to enable the Standby function.

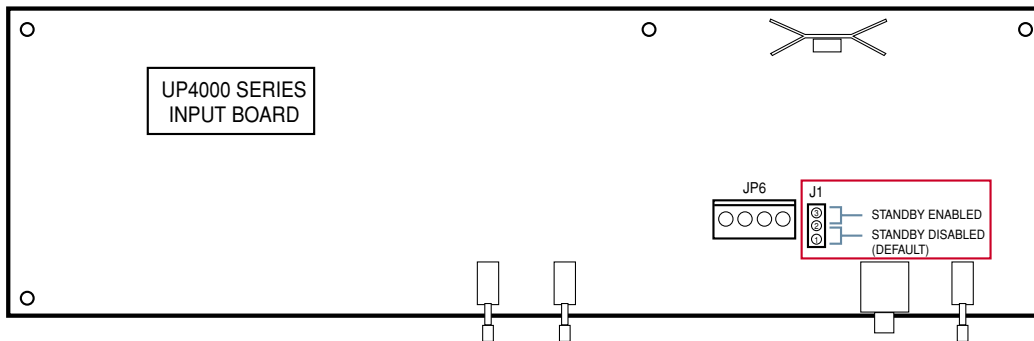

UP4000 Series Input Board Jumper

THERMAL CONSIDERATIONS

IMPORTANT: The UP4000 Series amplifier is convection cooled rather than fan cooled. Heat is drawn away from the amplifier by the heatsink and radiated through the cooling vents in the top cover. When installing the UP4000 Series, be sure to allow sufficient air space around the top and rear of the amplifier to allow adequate cooling for the heatsink. *Leave at least one rack space above and below the UP4000 and at least 6 inches behind the chassis to allow proper ventilation.*

If the amplifier should overheat, a thermal switch is activated that turns off the power amplifier, allowing the heatsinks to cool down. The ON indicator on the front panel will remain lit. Once the amplifier has cooled to a safe operating temperature, the thermal switch resets and reactivates the amplifier. If this should occur, identify the cause of the problem and take

corrective action (i.e., provide better ventilation, install a fan in the rack, make sure the amplifier is not overloaded by too low of a load impedance or by a short circuit on the speaker line).

AC POWER CONSIDERATIONS

The UP4000 Series draw an average AC line current as indicated on the following chart:

	115VAC	230VAC
UP4060	1.5A	0.8A
UP4120	4.0A	2.0A
UP4160	4.8A	2.4A

VOLTAGE CONVERSION

The UP4000 Series can be configured to operate at 115 VAC or 230 VAC. Be sure the **VOLTAGE SELECTOR** switch on the rear panel is set to the correct position for the AC power supply being used.

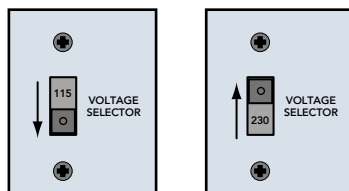

4. OPERATION

USING THE BALANCED IN

The **BALANCED IN** accepts a line-level signal. Connect the input source to the **BALANCED IN** barrier strip screw terminals.

PRIORITY FUNCTION

The **BALANCED IN** has priority over the **UNBALANCED IN**. The priority function can be activated by connecting a normally-open switch between the input **PRIORITY** terminal and the **GND** terminal on the **INPUT** barrier strip on the rear panel. Closing the switch activates the priority function and mutes the **UNBALANCED IN**.

USING THE UNBALANCED IN

The **UNBALANCED IN** accepts either a line-level signal (0 dB position) or a low-level signal (20 dB position), using the input **SENSITIVITY** switch.

HIGH-PASS FILTER

Push in the H.P. switch to engage the high-pass filter, which rolls off frequencies below 300Hz at 12 dB/octave.

LOW-PASS FILTER

Push in the L.P. switch to engage the low-pass filter, which rolls off frequencies above 7kHz at 12 dB/octave.

Note: The H.P. and L.P. filters affect both the balanced and unbalanced inputs.

USING THE PARALLEL OUT

The **PARALLEL OUT** connector is provided to connect the **UNBALANCED IN** signal to multiple amplifiers in a daisy-chain configuration.

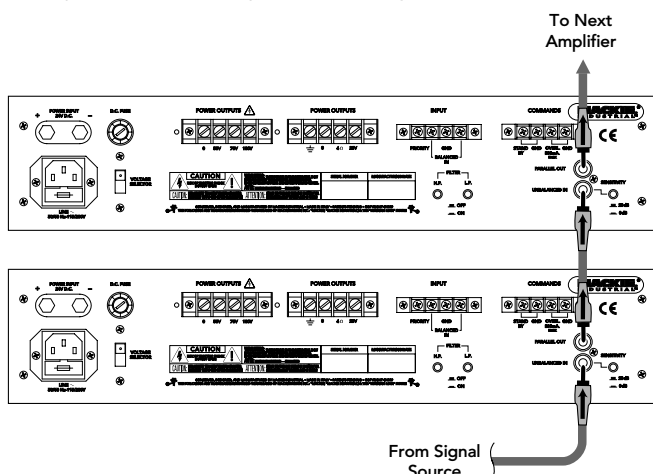

UP4000 Series Daisy-Chaining Inputs

COMMANDS STANDBY

An external normally-open switch can be connected between the **STANDBY** terminal and the **GND** terminal on the **COMMANDS** barrier strip on the rear panel. Closing the switch enables the signal to pass through the amplifier, and opening the switch puts the amplifier in standby mode (power on, no signal).

Note: The UP4000 Series is shipped with the Standby Mode disabled. Move jumper J1 on the input board to enable the Standby Mode (see instructions on page 8).

OVERL.

Connect an LED or relay between this terminal and the **GND** terminal to provide an external indication if the overload circuit has been activated. It provides +18 VDC with a maximum output capacity of 300mA when activated. See "Application Diagram" on page 6.

POWER OUTPUTS

The amplifier outputs on the UP4000 Series can be used with a 4-ohm impedance load, or to directly drive a 25V, 50V, 70V, or 100V distributed system (constant-voltage system).

DIRECT SPEAKER CONNECTION

If the UP4000 Series is not being used in a distributed speaker system, you can connect a speaker with a 4-ohm load between the "4Ω" terminal and the "0" terminal.

DISTRIBUTED SPEAKER SYSTEM

When using the UP4000 Series in a distributed system, connect the distributed system between the appropriate **POWER OUTPUT** terminal (25V, 50V, 70V, or 100V) and the "0" terminal. Make sure the speakers in the system are tapped appropriately so they do not exceed the rated power of the amplifier. (AM4060 = 60 watts, AM4120 = 120 watts, AM4160 = 160 watts).

POWER INPUT 24V D.C.

The UP4000 Series can be powered using a 24 VDC power supply. This can serve as the primary power supply for the UP4000 Series, or as a backup supply in case of an AC power failure. The UP4000 Series seamlessly switches to the backup supply if there is a power loss. When both AC power and 24 VDC power are connected, the AC power is used and no current is drawn from the DC supply.

Note: The unit is not equipped with battery charging capability.

5. SPECIFICATIONS

UP4000 SERIES BLOCK DIAGRAM

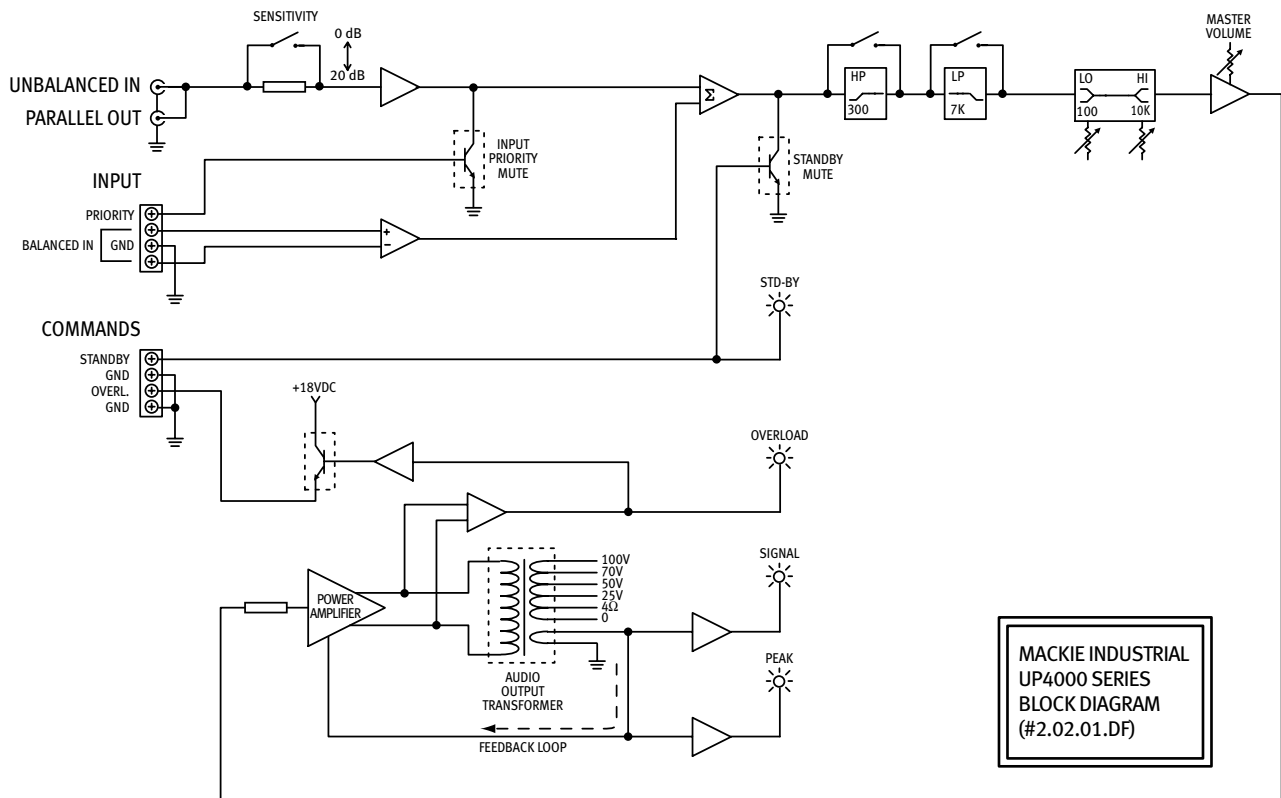

UP4000 SERIES SPECIFICATIONS

POWER AMPLIFIER SECTION

CONTINUOUS SINE WAVE AVERAGE OUTPUT POWER, BOTH CHANNELS DRIVEN:

UP4061:	60 watts RMS nominal; 90 watts peak (10ms)
UP4121:	120 watts RMS nominal; 180 watts peak (10ms)
UP4161:	160 watts RMS nominal; 220 watts peak (10ms)

FREQUENCY RESPONSE

50Hz to 15kHz (±3 dB)

DISTORTION

THD: < 1% @ 1kHz nominal power

SIGNAL-TO-NOISE RATIO

> 80 dB below nominal power

AUDIO INPUTS

Balanced Line Input: One active balanced barrier strip
 Unbalanced Line Input: One unbalanced RCA connector with Sensitivity switch

INPUT IMPEDANCE

Balanced Line Input:	100kΩ
Unbalanced Line Input:	
0 dB:	50kΩ
20 dB:	50kΩ

INPUT SENSITIVITY

Balanced Line Input:	775mV
Unbalanced Line Input:	
0 dB:	775mV
20 dB:	80mV

EQ

HP Filter:	300Hz @ 12 dB/octave
LP Filter:	7kHz @ 12 dB/octave

2-Band Output EQ:

High Shelving:	±12 dB @ 10kHz
Low Shelving:	±12 dB @ 100Hz

AUDIO OUTPUTS

Low Impedance:	4Ω
Constant Voltage:	25V, 50V, 70V, 100V
Unbalanced Out:	One unbalanced RCA connector, parallel to Unbalanced In

CONTROL INPUTS AND OUTPUTS

Inputs:	Priority switch, dry contact closure Standby switch, dry contact closure
Outputs:	Overload Indicator, 18 VDC @ 300mA

GENERAL

POWER CONSUMPTION

UP4060:	180 VA
UP4120:	450 VA
UP4160:	550 VA

AC LINE VOLTAGE

115 VAC, 60Hz
230 VAC, 50Hz

FUSE RATINGS

Model	Line Fuse 230 VAC	Line Fuse 115 VAC	24 VDC Fuse
UP4060	1.25AT	2.5AT	5AT
UP4120	2.5AT	5AT	10AT
UP4160	3.15AT	6.3AT	16AT

DIMENSIONS

Height:	3.5" (88mm)
Width:	17.0" (431mm)
Depth:	12.4" (314mm)
Weight:	UP4061: 22 lbs. (10.0kg) UP4121: 28 lbs. (12.7kg) UP4161: 31 lbs. (14.1kg)

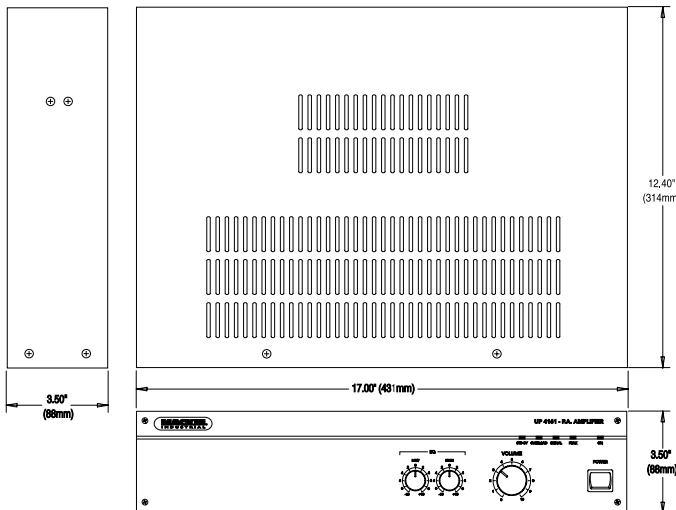

6. SERVICE INFORMATION

In the event that your UP4000 Series amplifier should require servicing, please follow these instructions:

1. Call Mackie Industrial Tech Support at 1-888-337-7404, 8 am to 5 pm PST (Monday-Friday), to verify the problem and obtain a Return Authorization (RA) Number. Be sure to have the serial number of the unit when you call. *You must have a Return Authorization Number in order to obtain warranty service at the factory or at an authorized service center.*
2. Pack the unit in its original packaging. **This is very important.** Mackie Industrial is not responsible for any damage that occurs during shipping due to non-conventional packaging. Original packaging helps to minimize the possibility of shipping damage.
3. Include a legible note stating your name, return shipping address, (no P.O. boxes), daytime phone number, Return Authorization Number, and a detailed description of the problem, including how we can duplicate it.
4. Write the Return Authorization Number in **BIG BOLD PRINT** on the top of the box.
5. Ship the unit to us. We suggest insurance for all forms of cartage. Ship to this address:

Mackie Industrial
Service Department
One Main Street
Whitinsville, MA 01588

Disclaimer

Mackie Industrial continually engages in research related to product improvement, new materials, and production methods. Design refinements are introduced into existing products without notice as a routine expression of that philosophy. For this reason, any current Mackie Industrial product may differ in some respect from its published description, but will always equal or exceed the original design specifications unless otherwise stated.

Mackie Industrial is a trademark of Mackie Designs Inc.

All other brand names mentioned are trademarks or registered trademarks of their respective holders, and are hereby acknowledged.

© 2001 All Rights Reserved.
Mackie Industrial.
Printed in the U.S.A.





**UP4000 SERIES
POWER AMPLIFIER**

**MACKIE®
INDUSTRIAL™**

www.mackieindustrial.com

16220 Wood-Red Road NE, Woodinville, WA 98072 USA

TEL 888.337.7404, FAX 425.487.4337, industrial@mackie.com

UK +44.1268.571.212, FAX +44.1268.570.809 industrial@rcf-uk.com

ITALY +39.0522.354.111, FAX +39.0522.926.208 industrial@rcf.it

FRANCE +33.3.8546.9160, FAX +33.3.8546.9161 rcf.commercial@wanadoo.fr

GERMANY +49.2572.96042.0, FAX +49.2572.96042.10 industrial@mackie.de

Free Manuals Download Website

<http://myh66.com>

<http://usermanuals.us>

<http://www.somanuals.com>

<http://www.4manuals.cc>

<http://www.manual-lib.com>

<http://www.404manual.com>

<http://www.luxmanual.com>

<http://aubethermostatmanual.com>

Golf course search by state

<http://golfingnear.com>

Email search by domain

<http://emailbydomain.com>

Auto manuals search

<http://auto.somanuals.com>

TV manuals search

<http://tv.somanuals.com>