



DEEP FRYER

INSTRUCTION MANUAL

Model: MCSDF12W



THANK YOU FOR PURCHASING A MAGIC CHEF PRODUCT. PLEASE READ ALL INSTRUCTIONS CAREFULLY BEFORE USING THE PRODUCT.

CONTENTS

SAFETY INSTRUCTIONS	3
IMPORTANT SAFEGUARDS	4
PARTS AND FEATURES	7
BEFORE USE	8
OPERATING INSTRUCTIONS	9
COOKING GUIDE	10
CARE AND MAINTENANCE	12
WARRANTY	13

What You Need to Know About Safety Instructions

Warning and Important Safety Instructions appearing in this manual are not meant to cover all possible conditions and situations that may occur. Common sense, caution and care must be exercised when installing, maintaining or operating this appliance.

Always contact your dealer, distributor, service agent or manufacturer about problems or conditions you do not understand.

Recognize Safety Symbols, Words, Labels

WARNING

WARNING-Hazards or unsafe practices which **COULD** result in severe personal injury or death.

CAUTION

CAUTION-Hazards or unsafe practices which **COULD** result in minor personal injury.

IMPORTANT SAFEGUARDS

WARNING

**SAVE THESE INSTRUCTIONS
FOR HOUSEHOLD USE ONLY**

IMPORTANT SAFEGUARDS

When using an electrical appliance, basic safety precautions should always be followed including the following:

- 1. READ ALL INSTRUCTIONS.**
2. This appliance is for household use only. Do not use outdoors.
3. Do not use this appliance for other than its intended use.
4. Before using for the first time, check if the voltage indicated on the base of the appliance corresponds to the voltage on the electrical outlet.
5. Do not turn the power on unless this appliance is properly assembled and filled with the recommended amount of oil or fat.
6. Close supervision is necessary when any appliance is used by or near children.
7. Do not operate any appliance with a damaged cord or plug, or after the appliance malfunctions or has been damaged in any manner.
8. The use of attachments or accessories not recommended or sold by the manufacturer may result in fire, electric shock or injury.
9. When not in use, assembling and disassembling, or before cleaning, unplug the appliance from the electrical outlet. Make sure the appliance cools down completely before assembling, disassembling and cleaning.
10. Do not immerse the heating element in water or any other liquid.
11. Do not let the cord hang over edge of table or counter.
12. Do not touch hot surfaces of the appliance. Use handles or knobs.
13. Leave about 6 to 8 inches of open space around the exterior of this appliance.
14. Do not place anything on top of this appliance.
15. Do not operate the appliance on a wall-mount, shelf or near flammable materials such as blinds, curtains, etc.
16. If the electric circuit is overloaded with other appliances, this appliance may not operate properly. This appliance should be operated on a separate electrical circuit from other operating appliances.
17. Do not clean the appliance with metal scouring pads.
18. Do not place on or near a hot gas or electric burner, or in a heated oven.
19. Do not use an external timer or a separate remote-control system for this appliance.
20. Only use oil or fat that does not foam and suitable for frying (see labels on the oil purchased).

21. The deep fryer must be filled with oil or fat between marks “MAX” and “MIN” inside the pot. Do not operate the Deep Fryer if it not filled with sufficient amount of oil or fat.
22. After use, turn the thermostat dial counterclockwise to the lowest temperature setting. Carefully remove the plug from the electrical outlet and allow the oil or fat to cool.
23. Do not move the deep fryer until its contents are completely cooled.

Notes on the cord plug

This appliance has a polarized plug. To reduce the risk of electric shock, this plug is intended to fit into a polarized outlet only in one way. If the plug does not fit fully into an electrical outlet, reverse the plug. If it still does not fit, contact a qualified electrician. Do not attempt to modify the plug in any way.

1. A shorter power-supply cord (or detached power-supply cord) is provided to reduce the risk resulting from being entangled in or tripping over a longer cord.
2. Longer detachable power-supply cords or extension cords are available and may be used if care is exercised in their use.
3. If a long detachable power-supply cords or extension cord is used:
 - A. The marked electrical rating of the detachable power-supply cord or extension cord should be at least equal or great than the electrical rating of the appliance.
 - B. If the appliance is a grounded type, the extension cord should be a grounding-type 3-wire cord.
 - C. The longer cord should be arranged so that it will not drape over the counter top or table top where it can be pulled on by children or tripped over.

WARNING:

To protect against electric shock, fire, and injury to persons, do not immerse main cord, plug, or unit in water or any other liquid.

This product is equipped with a polarized plug (one blade is wider than the other blade) as a safety feature to reduce the risk of electrical shock. This polarized plug will fit into a polarized outlet only one way; this is a safety feature. If the plug does not fit, contact a qualified electrician.

A short power supply cord is provided to reduce the risk of personal injury resulting from entanglement or tripping over a longer cord. Use of an extension cord is not recommended with this appliance.

Safety Thermal Cut-Out

This unit is designed with a safety thermal cut-out switch. If the deep fryer overheats, the safety thermal cut-out switch will automatically discontinue the power to the heating element. This can happen if the fryer is not filled with sufficient oil or the solid frying fat is not melted in the fryer. In the case of solid fat, the heating element is not able to radiate the produced heat quickly enough.

Frying with Solid Fat

We recommend the use of frying oil or liquid frying fat. When using fresh fat, allow the blocks of fat to melt slowly on moderate heat in a normal frying pan. Carefully pour the melted fat into the fryer. After the use, store the fryer with solidified fat in a cool, dark area.

CAUTION: If the fat is too cold, it can spatter when reheated. To prevent this, poke the solid fat with a fork. Be careful not to damage the heating element.

WARNING:

DO NOT plug in or turn on the deep fryer without oil in the removable oil pot.

DO NOT plug in or turn on the deep fryer if the oil is below the minimum recommended level.

DO NOT fill the removable oil pot above the maximum recommended level.

ONLY use oil or fats recommended for deep frying.

CAUTION:

IN THE EVENT OF AN OIL/GREASE FIRE, NEVER USE WATER TO EXTINGUISH THE FIRE. When water comes into contact with hot oil or grease, it will immediately vaporize and spread the oil or grease, inducing fire.

Fire caused by oil or grease should **ONLY** be extinguished with a fire extinguisher or by smothering with baking soda, salt or fire fighting foam.

PARTS AND FEATURES

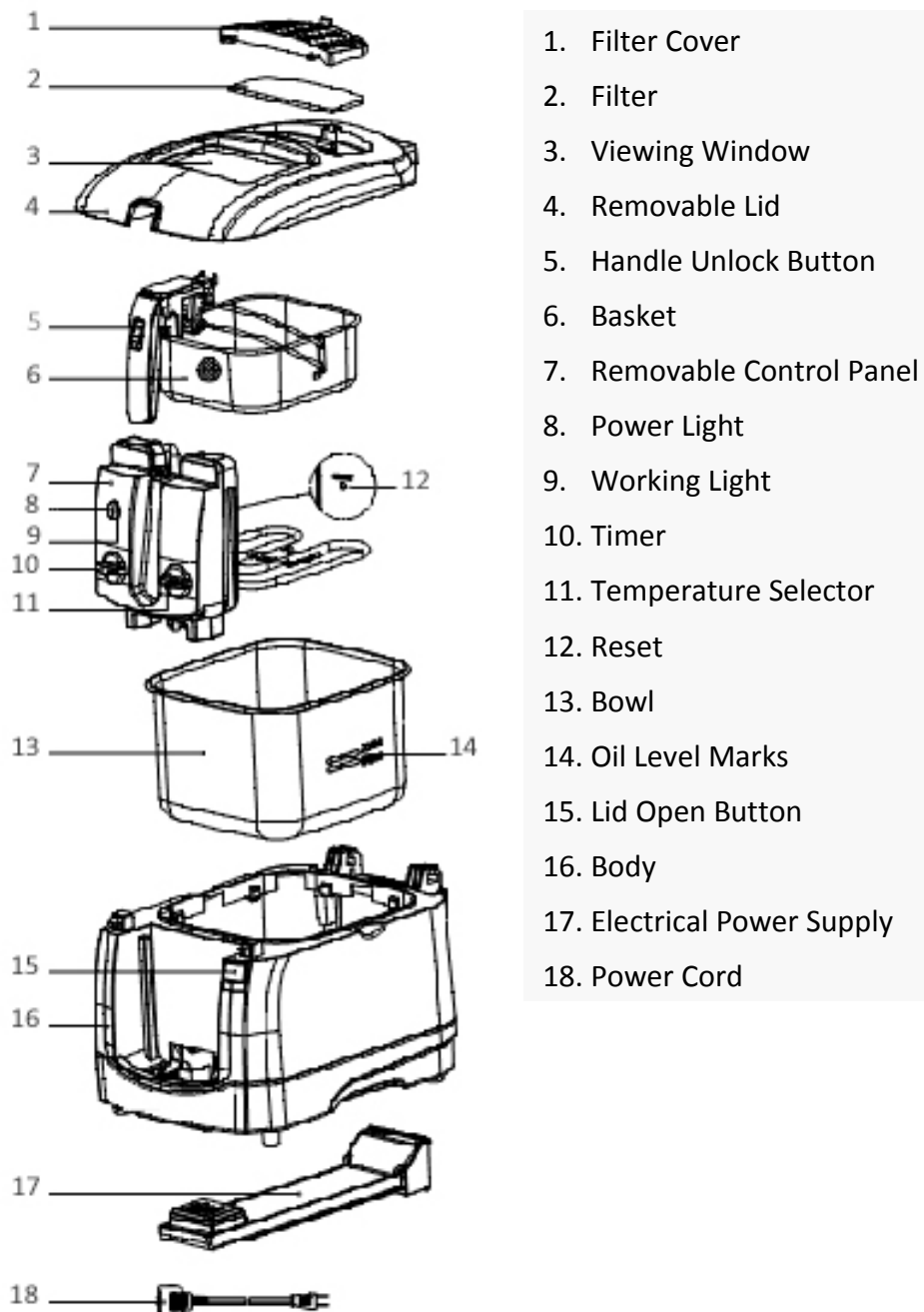

Specifications

- Voltage Rating: 120V 60Hz
- Power Rating: 1500 Watts
- Maximum Capacity: 3.2 Quarts

BEFORE USE

CAUTION: All electrical parts must remain dry at all times.

1. Before using the deep fryer for the first time, the individual parts must be cleaned using warm water and dried thoroughly as instructed in CARE AND MAINTENANCE. (Fig. 1)
2. Place the deep fryer on a horizontal, level, and stable surface.
3. Connect the Electrical Power Supply. (Fig. 2)
4. Insert the Filter and the Filter Cover. (Fig. 3)
5. Fill the dry and empty oil pot with oil or melted fat between marks "MAX" and "MIN" (see FRYING WITH SOLID FAT).
6. Never exceed the maximum level of oil or fat indicated in the bowl. (Fig. 4)
7. Never mix different types of fat or oil.
8. Never mix new oil with used oil.

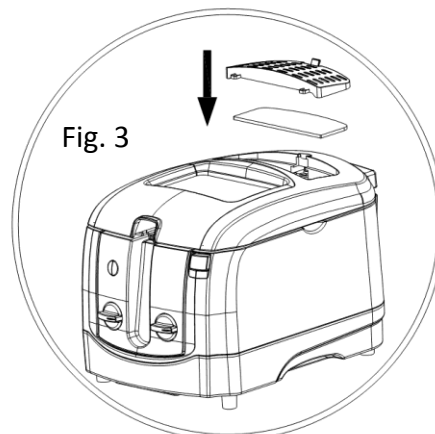
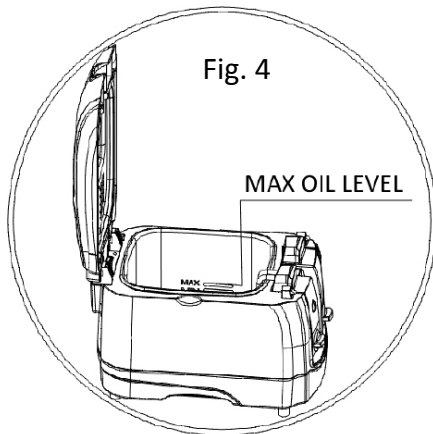
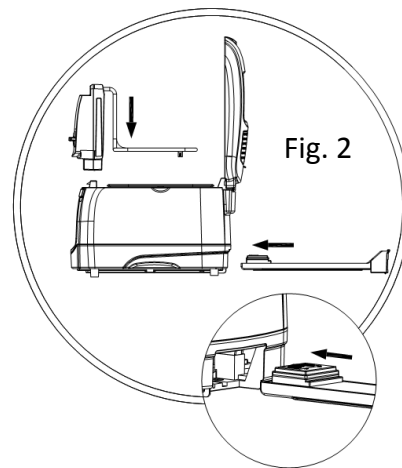
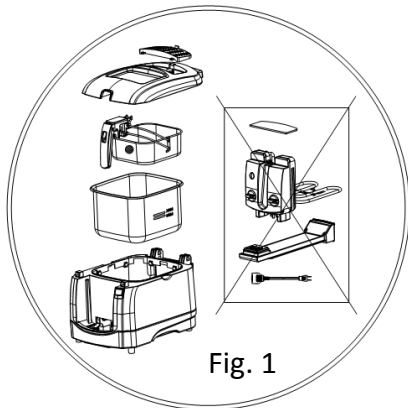

OPERATING INSTRUCTIONS

1. After filling the bowl with oil, connect the Electrical Power Supply and plug the Power Cord into an electrical outlet without the Frying Basket.
2. Set the Temperature Selector as recommended for frying certain food.
3. Remove the Frying Basket from the Deep Fryer.
4. Remove excess moisture (i.e. water and ice) from the food being fried.
5. Insert the food in the Frying Basket.

CAUTION: Do not overfill the Frying Basket. Reduce the food quantity for frozen food.

6. Place the Frying Basket on the edge of the Bowl while keeping the handle horizontal. (Fig. 5)
7. Close the Lid.

**NOTE: Cut food in similar sizes for frying evenly.
Avoid frying foods that are thick.**

8. When the oil reaches the selected temperature, WORKING LIGHT will turn off.
9. Press the Handle Unlock Button and fold the Handle very slowly for lowering the Frying Basket in the oil.

CAUTION: Do not plunge the Frying Basket in the oil.

10. Set the Timer to the desired time.
11. While frying, it is normal for the temperature light to turn on and off.
12. The Timer will chime when the cooking cycle completes.
13. After the Deep Fryer shuts off, lift the Basket Handle horizontally until it locks with a clicking sound.
14. Turn the Temperature Selector to the lowest setting.
15. Open the Lid.
16. Remove the Frying Basket completely out of the Deep Fryer.

NOTE: Close the Lid when the Deep Fryer is not in use.

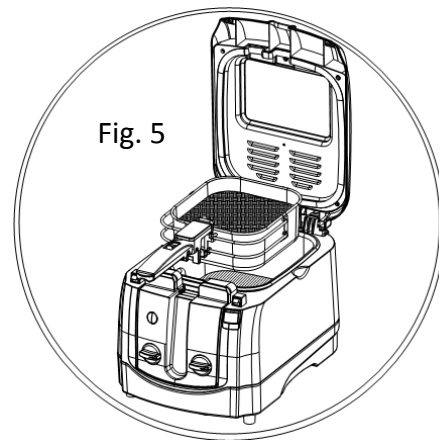

COOKING GUIDE

This chart is only a guide and should be adjusted accordingly.

FOOD	OIL TEMPERATURE (in Fahrenheit)	WEIGHT (in grams)	ESTIMATED COOKING TIME (in minutes)
Shrimp	265	250	3 to 5
Mushrooms	300	300	3 to 5
Crumbed Chicken	340	500	12 to 14
Whole Shrimp	340	250	2 to 4
Fish Cakes	340	400	3 to 5
Filletts	340	400	4 to 6
French Fries (1st time)	340	550	8 to 10
French Fries (2nd time)	375	550	2 to 4
Onion	375	150	2 to 4
Potato Chips	375	150	2 to 4

*Oil should be warmed-up for 10-15 minutes.

*You can make French Fries lighter and crispier by frying twice.

*Use a maximum of 200 grams of French Fries per liter of oil.

TIPS

How to make delicious, crispy chips:

1. Potatoes intended for deep-frying should reflect fresh appearance.
2. Floury or firm potatoes should be used for deep-frying.
3. After peeling the potatoes, cut them as desired (strips or slices).
4. Lay the potatoes in water for about one hour before use. Part of the sugar, one of the primary substances responsible for the formation of acrylamide, is then released.
5. Allow the potatoes to dry thoroughly.
6. Always deep-fry home-made chips twice; 4-6 minutes at 300°F for the first time and 2-4 minutes at 340°F for the second time.
7. When deep-frying for the second time, lift the basket out of the fryer a few times and shake the basket to loosen the chips.
8. Deep-frozen chips are pre-cooked and therefore only need to be deep-fried once. Please follow the instructions on the cooking instructions of the food.

Deep-Frozen Products

Deep-frozen products (-61 to -64°F) will cool the oil or fat and therefore do not fry the food quickly enough to absorb much oil or fat. This can be prevented as follows:

1. Do not fry large quantities at once (see Table).
2. Allow the deep-frozen food to defrost at room temperature. Remove as much ice and water as possible before placing the food in the fryer.
3. Pre-heat the oil for at least 15 minutes.
4. Set the temperature specified in these instructions or on the food package.
5. Place the food slowly and carefully in the fryer since frozen foods have the tendency to cause the hot oil or fat to abruptly bubble.

How to remove undesired tastes

Some fried food releases liquid which accumulates in the frying oil or fat and affects the smell and taste of other food subsequently fried in the same oil or fat. The taste of the oil or fat can be neutralized by the following procedure:

1. Heat the oil or fat to 300°F
2. Add two thin slices of bread or some parsley to the deep fat fryer.
3. Wait until the oil or fat stops bubbling and remove the bread or parsley with a slotted spoon.
4. The taste of the oil or fat should be neutralized.

Healthy eating

Nutritionists recommend the use of vegetable oils and fats containing unsaturated fatty acids (e. g. linoleic acid). However, these oils or fats may lose their positive properties quicker than other types; hence they need to be changed more frequently.

CARE AND MAINTENANCE

Cleaning

CAUTION: Oil or fat must be cooled to room temperature before removal and/or disposal.

1. Disconnect the plug from the electrical outlet.
2. Remove the lid and basket. Remove the oil pot from the fryer and pour out the oil or fat.
3. The control/heating element should never be immersed in water or cleaned under running water. These parts must be cleaned with a moist cloth if necessary.
4. Clean the lid, bowl and basket with mild dishwashing detergent in hot water. Rinse with clean water and dry thoroughly. Do not use any abrasive cleaning agents or materials.
5. Reassemble the fryer by inserting the bowl and basket and attaching the lid.
6. Attach the handle by folding it into the basket.
7. Wrap and store the power cord inside the empty oil pot.
8. Lift the fryer with the aid of the side carrying handles.
9. Store the fryer with the lid closed in a cool, dark area. This will keep the inside of the fryer clean and dust-free.

Storing Oil

CAUTION: Oil or fat must be cooled to room temperature before removal and/or disposal.

1. If the fryer is not used regularly, it is recommended to store the oil or fat, after cooling, in a container and then placed in a refrigerator or other cool, dark area.
2. Filter the oil or fat through a fine sieve before storing in a container to remove food particles from the oil or fat. If the fryer is used mostly for chips and the oil or fat is sieved after each use, it may be re-used several times.
3. For best results, change the oil or fat regularly. Do not re-use oil for longer than six months. Observe the instructions on the food label.
4. Change the oil or fat if it begins to foam when heated, develops a strange taste or smell or becomes dark and/or has a syrup-like consistency.

Disposing Oil

CAUTION: Oil or fat must be cooled to room temperature before removal/or and disposal.

Used oil or liquid fat can be best disposed of by pouring it back into the original plastic bottle and sealing properly. Solid fat should be solidified in the fryer and removed with a spoon or spatula. Removed solid fat may be placed in a paper type of material such as newspaper. Bottles or newspapers containing used oil or fat should be disposed of in accordance to the applicable national or state regulations.



LIMITED WARRANTY

Unless otherwise prohibited, MC Appliance Corporation warrants each **DEEP FRYER MCSDF12W** to be free from defects in material and workmanship and agrees to remedy any such defect or to furnish a new part(s) (at the company's option) of the unit that fails during the warranty period. **A copy of the dated sales receipt or invoice is required to receive warranty service or a refund.**

This warranty covers an appliance in use within the continental United States, Puerto Rico and Hawaii. The warranty does not cover the following:

- Damages due to shipping or improper installation.
- Damages due to misuse or abuse.
- Content losses due to failure of the unit.
- Repairs performed by unauthorized service agents.
- Service calls that do not involve defects in material and workmanship such as instruction on proper use of the product or improper installation.
- Failure of this product if used for other than for its intended purpose.
- Disposal costs for any failed unit not returned to our factory.
- Any delivery costs incurred as the result of a unit that fails to perform as specified.

This warranty is in lieu of any and all warranties expressed or implied and no representative or person is authorized to assume for us any other liability in connection with the sale of this product. Under no circumstances is the consumer permitted to return this unit to the factory without prior written consent from MC Appliance Corporation.

Model	Parts & Labor	Type of Service
MCSDF12W	One-Year	Carry-In

For Service or Assistance please call

888-775-0202

Or visit us on the web at www.magicchef.com to request warranty service

Free Manuals Download Website

<http://myh66.com>

<http://usermanuals.us>

<http://www.somanuals.com>

<http://www.4manuals.cc>

<http://www.manual-lib.com>

<http://www.404manual.com>

<http://www.luxmanual.com>

<http://aubethermostatmanual.com>

Golf course search by state

<http://golfingnear.com>

Email search by domain

<http://emailbydomain.com>

Auto manuals search

<http://auto.somanuals.com>

TV manuals search

<http://tv.somanuals.com>