

Installation and Operations Manual

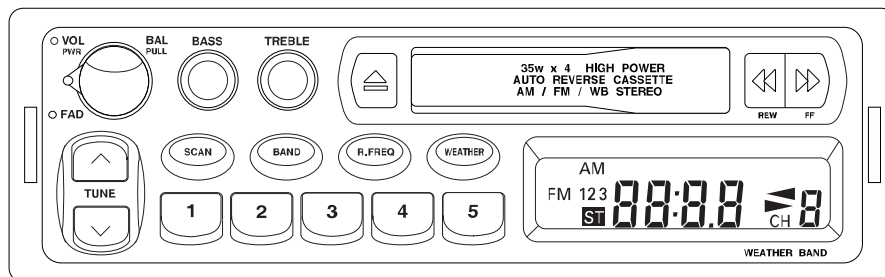

M9850 High Power (35 Watts x 4) AM/FM/WB Stereo Receiver and Auto Reverse Cassette Deck

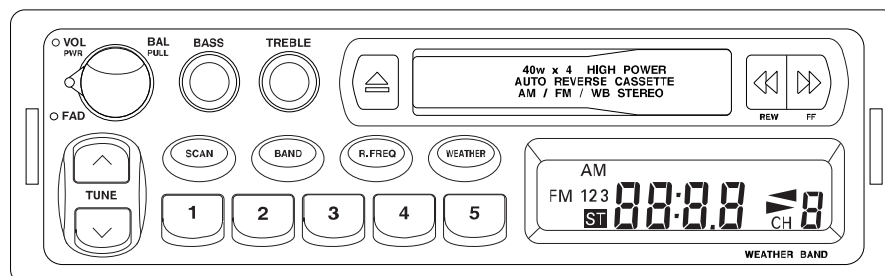

M9860 High Power (40 Watts x 4) AM/FM/WB Stereo Receiver and Auto Reverse Cassette Deck

Introduction

Your new AM/FM/WB cassette unit incorporates a microcomputer managed electronic AM/FM stereo tuning system and FM Optimizer along with rugged auto reverse cassette mechanism. The two as a combination will provide the user with the finest crystal clear AM/FM stereo radio broadcast reproduction and flawless reproduction of your personal cassette tape library.

To insure trouble free long term performance from your new unit, please

take a moment to read this manual completely to make yourself aware of all basic radio operation and memory setting procedures.

Also at this time, it would be a good idea to write down the serial number of the unit in the space provided. In the unlikely event that the radio will need warranty service, you will need this number to obtain the service.

Serial # _____

Mechanical Installation

Space Requirements:

To mount your new AM/FM cassette unit, you will need a rectangle hole in the mounting location 182mm (width) x 53mm (height), ($\frac{7}{8}$ " x $2\frac{1}{8}$ ") and a full 6" of unobstructed space behind the mounting location.

Step 1:

After obtaining the required space and mounting hole dimensions required, remove the mounting sleeve from the unit. Insert the mounting sleeve into the hole on the dashboard. Secure it by bending the tabs inward as shown in fig 1. Select the appropriate tab according to the thickness of the dashboard.

Step 2:

Bring the power, ground, antenna and speaker wires through the center of the mounting sleeve. Make all the speaker and power connections to the main harness supplied with the unit. Refer to the "wiring" section of

this unit for proper connection. After all the connections have been made and are correct, plug the harness and the antenna cable into the mating plugs located on the rear of the unit.

Step 3:

Turn on the ignition key and do a pre-installation check of all the functions with the unit out of the dashboard to make sure that everything is operating properly before final installation.

Step 4:

Securely attach the rear support strap provided to the rear of the unit with the fasteners provided. Bend the strap to allow the unit to slide into its mounting sleeve. Reach up behind the unit and grab the strap while sliding the unit into the mounting sleeve until it snaps into place. Secure the end of the strap to a solid portion of the dashboard structure or the fire wall.

Installation Procedure

Removing the Unit:

In the event that the unit requires removal from its mounting location, repeat the following procedures.

- A. Release the rear support strap.
- B. Insert the keys provided into the slot on both sides of the chassis until locked. (snapped into place)
- C. Pull on the keys with equal pressure to release and remove the unit from the mounting sleeve.
- D. Disconnect the wire harness and the antenna.

Wiring:

Note 1: If you are installing a completely new system, install all of the speakers and antenna first, then run the wires up to the radio mounting location and bring them through the radio mounting hole.

Note 2: Your new AM/ FM cassette unit has been designed to operate properly when connected to a "12 Volt Negative Ground" electrical system. Any other power supply may not be acceptable. Connecting your new unit to other than the specified power source will damage the unit and will void the warranty. If you are not sure that your vehicle uses a "12 Volt Negative Ground" electrical system, contact your local car stereo installation center and find out before making any connections.

Red Wire:

Connect the red wire to a source of 12 volts that is controlled by the ignition key. Use a test light or volt meter to locate a connection point at the fuse block.

Black Wire:

Connect the black wire to the frame of the vehicle. It is strongly recommended that the black wire be connected to a part of the vehicles frame, floorboard or sub structure to insure a good ground. It is Not advisable to connect the black wire to a factory provided ground wire. It is possible that many other electrical items will be connected to this wire and electrical noises such as pops and clicks could be present in your speakers. In addition, shared grounds tend to amplify engine noise into the unit and you will hear the noise in your speakers.

Orange Wire: (with fuse holder)

Connect the orange wire to a constant source of 12 volts. The battery (+) post or the battery portion of the fuse block is a good location for this wire. Use a test light or volt meter to locate a connection point at the fuse block.

Installation Procedure

Figure 1

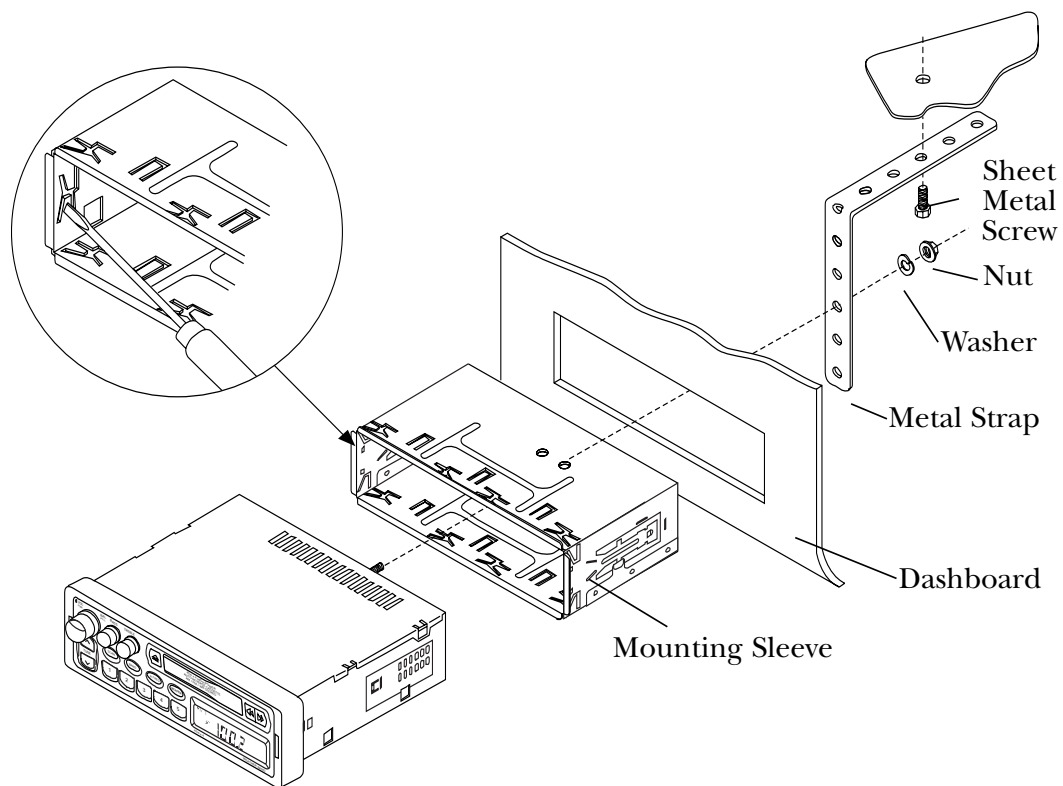

Removing the Unit

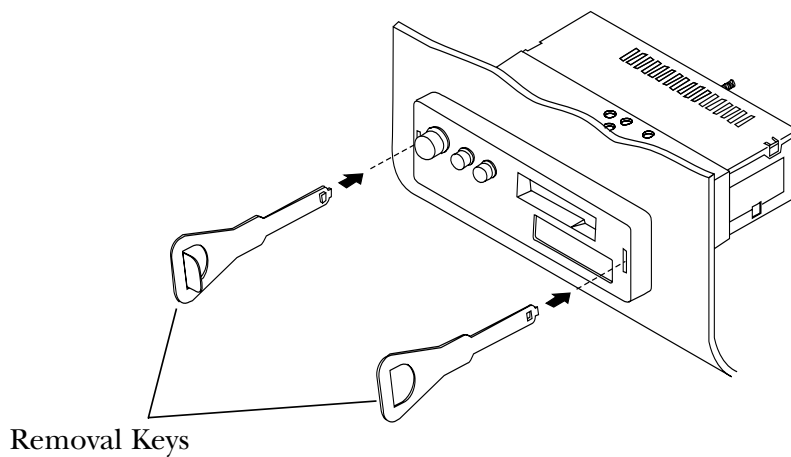

Installation Procedure

Speaker Connections:

Note: Every speaker has a positive (+) and a negative (-) connection terminal, therefore every speaker must have two wires connected to it. To properly connect the speaker system to your new AM/FM cassette unit, you must have a + and - wire coming from every speaker to connect to the unit.

If you are connecting 2 speakers, you should have 4 wires to connect. If you are connecting 4 speakers, you should have 8 wires to connect.

Wiring Four Speakers:

(Fader Control Operational)

Green Wire:

Connect the Green wire to the Left Front speaker "Positive" wire.

Green/Black Wire:

Connect the Green/Black wire to Left Front speaker "Negative" wire.

Green/Red Wire:

Connect the Green/Red wire to the Left Rear speaker "Positive" wire.

Black/Green Wire:

Connect the Black/Green wire to the Left Rear speaker "Negative" wire.

Gray Wire:

Connect the Gray wire to Right Front speaker "Positive" wire.

Gray/Black Wire:

Connect the Gray/Black wire to the Right Front speaker "Negative" wire.

Gray/Red Wire:

Connect the Gray/Red wire to the Right Rear speaker "Positive" wire.

Black/Gray Wire:

Connect the Black/Gray wire to the Right Rear speaker "Negative" wire.

Wiring Two Speakers:

Green Wire:

Connect the Green wire to the Left speaker "Positive" wire.

Green/Black Wire:

Connect the Green/Black wire to the Left speaker "Negative" wire.

Gray Wire:

Connect the Gray wire to Right speaker "Positive" wire.

Gray/Black Wire:

Connect the Gray/Black wire to the Right speaker "Negative" wire.

Warning !

1. Do Not Ground any speakers to the frame of the vehicle or to any other grounding system.
2. The fader control used in the M9850/M9860 radio can not be deleted. When connecting two speakers to the unit, use only the front set of wires provided in the harness. Insulate the remaining rear speaker wires provided in the harness. (Tape the wires)
3. Do Not Connect the left front and left rear wires together for any reason. This will damage the unit.

Installation Procedure

Four Speaker Wiring

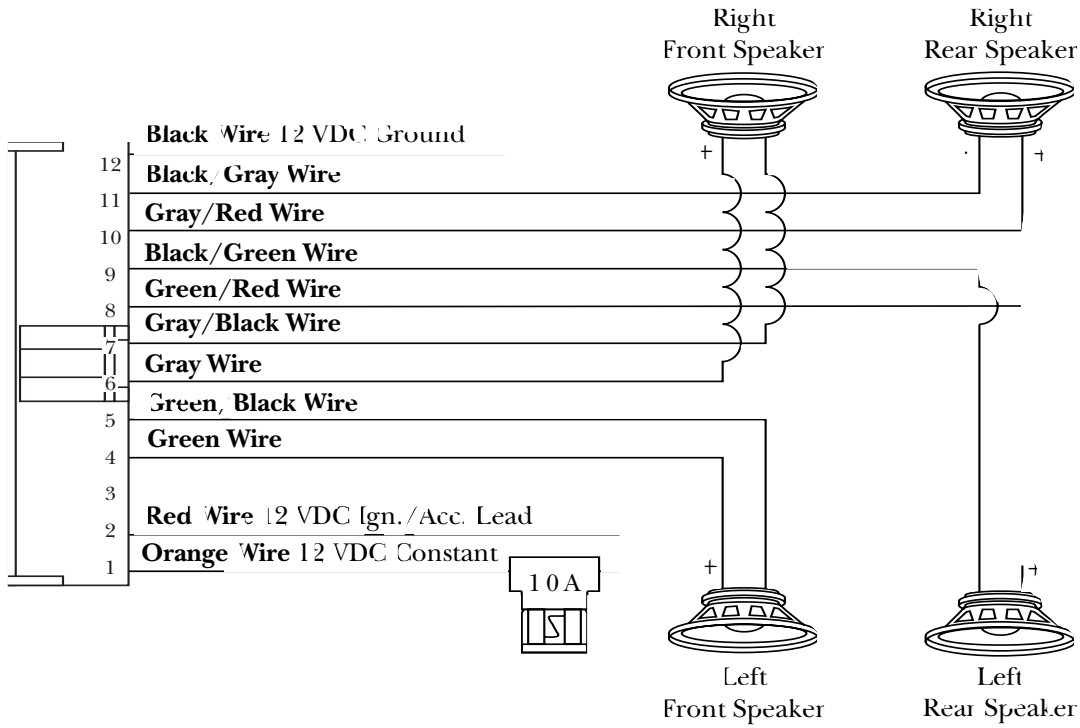

Two Speaker Wiring

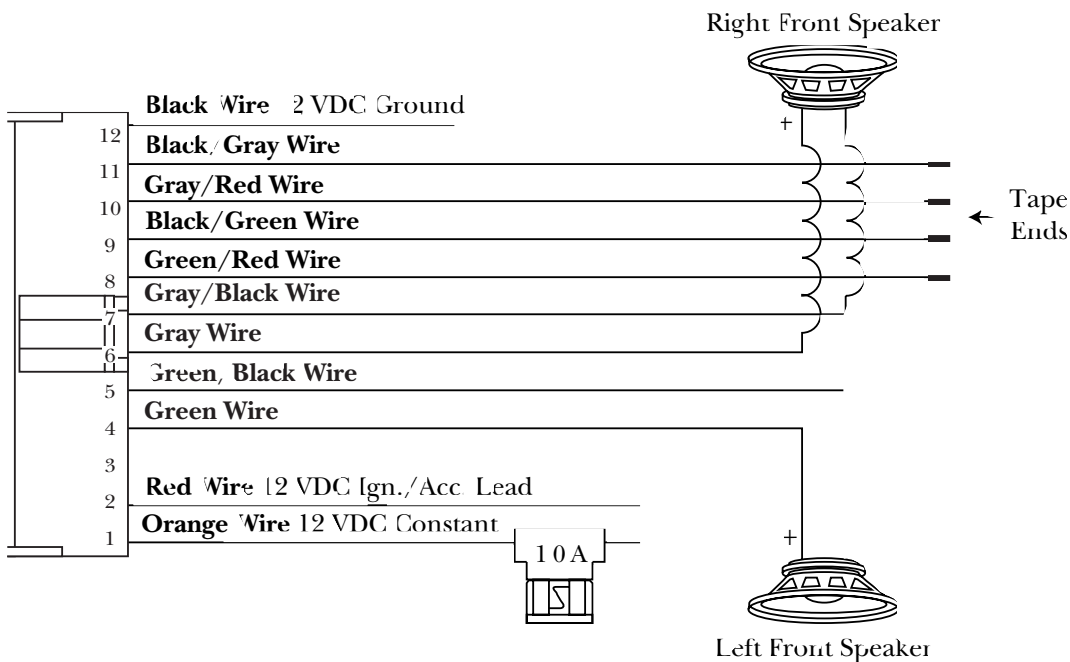

Control Button Identification

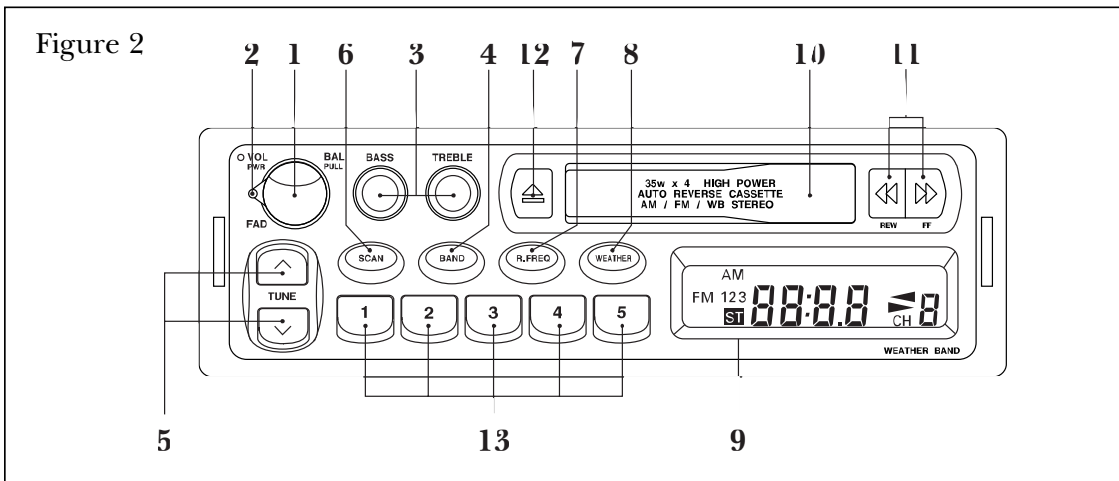

1. On/Off Power Switch, Balance Control and Volume Level Adjuster.
2. Fader Control.
3. Bass/Treble Tone Controls.
4. Radio Band Selector Button.
5. Manual Tuning Control Buttons.
6. Radio Station Scan Button.
7. Frequency Selector Button.
8. Weatherband Radio Selector Switch.
9. Display.
10. Tape Door Slot.
11. Fast Forward and Rewind Buttons.
12. Eject Button.
13. Preset Stations Buttons.

Radio Display

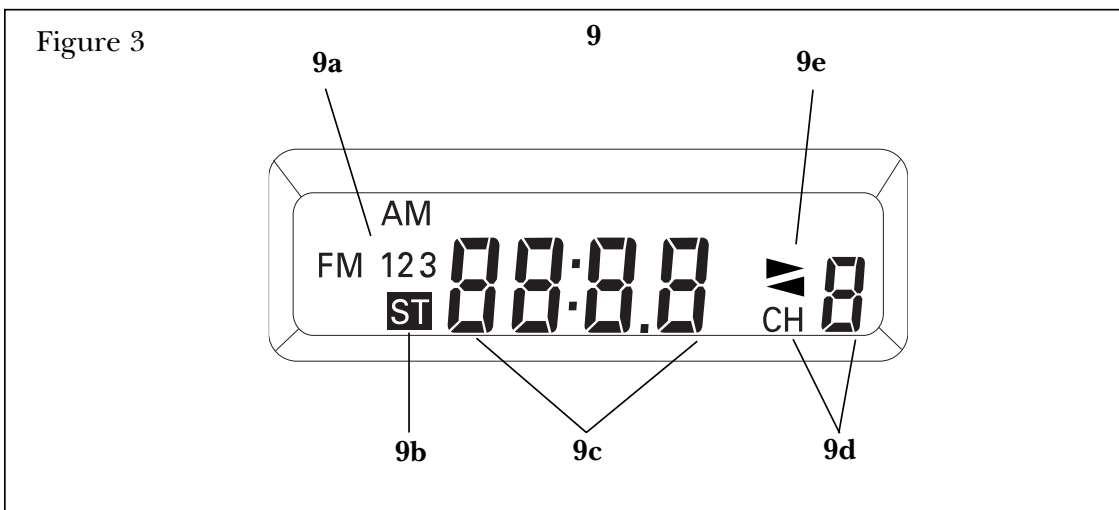

Radio Display

Figure 4

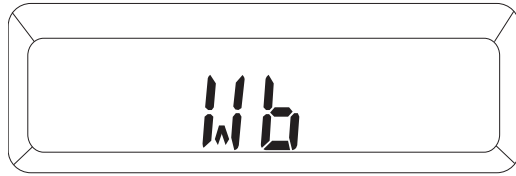

Using the Radio

Listening to the Radio:

1. Turn the vehicle's ignition key to the "on" or "acc" position to provide power to the radio.
2. Rotate knob (1) clockwise to turn the radio on. Adjust the volume knob (1) to a low listening level.
3. Use the band button (4) to select the AM or FM radio band. The FM band has 3 banks (FM1, 2, and 3). The AM band has 2 banks (AM 1 and AM 2)
4. Use the tuning button (5) to select a desired radio station. Press the "∧" (up) button to tune to higher radio stations. Use the "∨" (down) button to tune to lower radio stations. Pressing and releasing the tuning control buttons (5) will cause the tuner to move up or down two decimal increments. Pressing and holding the up or down tuning buttons (5) will cause the tuner to count up or down at high speed.
5. If you are traveling in an area where you are not familiar with the local radio stations, Press and release the scan button (6). This will activate the auto tuning system and the tuner will scan up to the next available strong station and stop for 5 seconds. After 5 seconds has passed, the tuner will search up to the next strongest station and stop. If you find a station to your liking, simply press and release the scan button once again to stop the scan operation.
6. Adjust the treble, bass, fader, balance and volume controls as needed using the information "Audio adjustments" section of this manual.

Display Priority Note:

The priority of the display area (9) is for the clock. 5 seconds after the last tuning control command, the display will change and display the clock. To recall the radio frequency, press and release the "R.Freq" button (7). The display will change to show the radio frequency then will revert back to the clock after 5 seconds.

Using the Radio

Listening to the Weatherband Radio

1. At any time when the AM/FM radio or tape is playing, you can press the “Weather” button (8). The automatic weatherband seek tuning will begin to find the strongest broadcast frequency in the area you are traveling in . When the weatherband radio is activated, “WB” will appear in the display area (Figure 4). Once the tuner has locked on to a station, the weatherband radio will operate.
2. To turn the weatherband radio off, press the “weather” button (8) once more and the unit will return to the signal source (AM/FM or Tape) you were previously listening to.
3. 7 weather stations are available. If you would like to scroll through the stations, press the weather button (8) to activate the weatherband and then press the “^” or “v” tuning button (5) to scroll up or down the 7 stations.

Note: All 7 stations may not be available in the area you are traveling in.

Cassette Operation

Some Notes About Cassette Tapes

- * It is not recommended to use any tape with a length longer than 90 minutes playing time. Longer tapes create excessive load on the tape motor and mechanism causing premature wear and failures. Longer tapes have a tendency to tangle and jam automotive tape mechanisms.
- * Cassette tape housings that are warped or that have loose indicator labels should not be used. Doing so will result in the tape becoming jammed in the mechanism.
- * Storing cassette tapes in areas directly exposed to sunlight or high temperatures will cause the cassette cases to warp rendering them unusable. Store cassette tapes in a case designed specifically for that purpose. This will prevent warpage and foreign material contamination.

Periodic Tape Mechanism Cleaning

While the tape is playing, small deposits of foreign material attach themselves to the tape head, pinch rollers and capstans of the tape player mechanism. Failure to periodically clean the foreign material off will result in poor sound quality and a tape mechanism that will "eat" cassette tapes. To prevent this from happening, the use of a good quality "wet type" cassette head and capstan cleaner is recommended every 10 hours of use.

FAILURE TO CLEAN THE TAPE DECK AT REASONABLE INTERVALS WILL RESULT IN TAPE DECK SERVICE THAT IS NOT COVERED BY WARRANTY.

How to Listen to a Tape

1. Turn the vehicles ignition key to the ON or ACC position to provide power to the radio.
2. Rotate knob (1) clockwise to turn on the unit. Adjust the volume knob (1) to a low listening level.
3. Insert a cassette tape into the the cassette opening (10) with the thick side pointing toward the right
Note: The cassette tape will only fit in one direction. If the tape does not insert easily, DO NOT FORCE IT. Turn the tape over and reinsert it. At this time the display (9) will be showing the tape play indicators (9e)
4. Adjust the volume, bass and treble controls to suit your taste.

Changing the Tape Program

Cassette tapes have two playing sides, side (A) and side (B). The cassette player in this unit will play either side of the tape. If you wish to change play from side (A) to side (B) or vice versa, press and release the FF and REW buttons at the same time. The tape play indicator (9E) will show the new direction and the tape will begin to play.

Note: If the tape is allowed to run to the end of the side that is playing , it will automatically change over to the remaining side and play.

Cassette Operation Programming

Using the Fast Forward and Rewind Controls

The two buttons located to the right side of the tape opening (10) are the fast forward and rewind buttons (11). While the tape is playing you can use these buttons to fast advance the tape to search for special sound tracks or rewind the tape to listen to it from the beginning. To operate these buttons, simply press one or the other in until it locks. To release it, press the opposite button slightly. The "FF" button will always fast advance the tape forward and the "REW" button will always fast rewind the tape.

Listing to the Radio Tuner While Fast Advancing the Tape

To listen to the AM/FM radio while the tape is rewinding or fast forwarding, press the "R.FREQ" button after the FF or REW button is pushed. This will turn on the radio tuner until the FF or REW button is released and the tape begins to play again. Once this feature is turned on, each time the "FF" and "REW" buttons are pushed, the radio tuner will come on automatically. If you want to turn this feature off, press the "R.FREQ" button while the tape is fast forwarding or rewinding. The tuner will be off.

Programming the Radio Station Recall Buttons

1. Rotate knob (1) clockwise to turn on the unit. Adjust the volume knob (1) to a low listening level.
2. Use the band button (4) to select the AM or FM radio band you want to memorize a radio station. The FM band has 3 banks (FM 1, 2, and 3). The AM band has 2 banks (AM 1 and 2). Continue pressing the band button (4) until the desired radio band is displayed (9a).
3. Use the tuning button (5) to select a desired radio station. Press the "Λ" (up) button to tune to higher radio stations. Use the "∇" (down) button to tune to lower radio stations. Pressing and releasing the tuning control buttons (5) will cause the tuner to move up or down two decimal increments. Pressing and holding the up or down tuning buttons (5) will cause the tuner to count up or down at high speed.
4. Once the desired station is selected, press and hold down one of the 5 station recall buttons (13) until the channel indicator (9d) is displayed, release the button. The station is now memorized to the band indicated (9a) and the recall button indicated (9d). Repeat procedures 2 thru 4 for all 5 preset buttons.
5. Select another radio bank and repeat steps 2 thru 4 above to memorize all 15 FM radio stations and 10 AM radio stations.

Clock Settings

Setting the Clock with the Radio Off

1. Turn the vehicles ignition key to the ON or ACC position to provide power to the radio. You will know that radio has sufficient power as the clock will be displayed in the LCD display window (9).
2. Press the 'R.FREQ" button (7) and hold it down.
3. Adjust the HOURS by pressing the "V" (down) tuner control button (5) until the correct hour is displayed.
Note: The clock is a 12 hour clock and does not indicate " AM or PM".
4. Adjust the MINUTES by pressing the " ^ " (up) tuner control button (5) until the correct minutes are displayed.

Setting the Clock with the Radio On

1. While the radio is on, press the 'R.FREQ" button (7) to display the time. Hold the button down.
2. Adjust the HOURS by pressing the "V" (down) tuner control button (5) until the correct hour is displayed.
Note: The clock is a 12 hour clock and does not indicate " AM or PM".
3. Adjust the MINUTES by pressing the " ^ " (up) tuner control button (5) until the correct minutes are displayed.

Audio Adjustments

Volume Level

1. Rotate the volume control knob (1) clockwise to increase the volume.
2. Rotate the volume control knob (1) counter clockwise to decrease the volume.

Left to Right Balance

1. Pull the volume control knob (1) outward until it locks.
2. Rotating the knob to the left will balance the speakers to the left.
3. Rotating the knob to the right will balance the speakers to the right
4. The mechanical center of the control has a “click” feel to it.
5. When the speaker balance is set as desired, unlock the knob by pushing on it. The knob will now adjust the volume.

Front to Rear Speaker Balance (Fader Control)

Rotate the fader control clockwise or counter clockwise to adjust the speaker balance from the front of the vehicle to the rear of the vehicle.

Bass Tone Control

1. Rotate the bass control (3) clockwise to increase the bass tones.
2. Rotate the bass control (3) counter clockwise to decrease the bass tones.
3. The mechanical center of the control has a “click” feel and is considered flat.

Treble Tone Control

1. Rotate the treble control (3) clockwise to increase the high tones.
2. Rotate the treble control (3) counter clockwise to decrease the high tones.
3. The mechanical center of the control has a “click” feel and is considered zero.

Loudness Boost

1. The loudness boost is automatic. For the first 1/2 rotation of the volume control, the loudness circuit is active and will boost up the low range (100Hz) and high range (10Khz) to compensate for the music tones that are not normally heard at low volume listening.
2. After the volume control is rotated past the 1/2 way mark, the loudness effect will diminish as at these higher volumes, the boost is not needed.

Specifications

AM/FM Tuner

| | |
|-----------------------------|--------------------|
| FM Frequency Range | 87.5 - 107.9MHz |
| AM Frequency Range | 520 - 1720 KHz |
| IF Rejection | AM 45dB FM 70dB |
| Image Rejection | AM 55dB FM 55dB |
| Selectivity | AM 30dB FM 60dB |
| S/N ratio (Signal to Noise) | AM 48dB FM 65dB |
| Stereo Separation | 32dB |

Cassette:

| | |
|--------------------|------------------------|
| Wow & Flutter | Less than 0.35% WRMS |
| Signal to Noise | Ratio Better than 45dB |
| Frequency Response | 60Hz - 10kHz |

General:

| | |
|--------------------|----------------------------------|
| Power Requirements | 11.2V - 14.4V DC Negative Ground |
| Treble Control | ± 10dB @ 10kHz |
| Bass Control | ± 10 dB @ 100Hz |

Speaker Impedance Requirements

4 or 8 Ohm

Output Power:

M9850

20 Watts x 4 @ 10% THD

35 Watts x 4 Max

M9860

22 Watts x 4 @ 10% THD

40 Watts x 4 Max

Weight 2.5 lbs.

Features and Specifications are subject to change and improvement without notice.

Notes:

Warranty

ONE (1) YEAR LIMITED WARRANTY

Magnadyne Corporation or its authorized agents will within 1 year from the date of sale to you, repair, replace or refund the retail sales price of said product or any part thereof, at the option of the Magnadyne Corporation or its authorized agents, if said product or part is found defective in materials or workmanship, when properly connected and operating on the correct power requirements designated for the specific product. This warranty and Magnadyne Corporation or its authorized agents obligations hereunder do not apply where the product was; damaged while in the possession of the consumer, subjected to unreasonable or unintended use, not reasonably maintained, utilized in commercial or industrial operations, or serviced by anyone other than Magnadyne Corporation or its authorized agents, or where the warning seal on the product is broken or the power and/or plugs are detached from the unit. Magnadyne Corporation or any of its authorized agents will not assume any labor costs for the removal and re-installation of any product found to be defective, or the cost of transportation to Magnadyne Corporation or its authorized agents. Such cost are the sole responsibility of the purchaser.

This warranty does not cover the cabinet appearance items or accessories used in connection with this product, or any damage to recording or recording tape, or any damage to the products resulting from improper installation, alteration, accident, misuse, abuse or acts of nature.

MAGNADYNE CORPORATION OR ITS AUTHORIZED AGENTS SHALL NOT BE LIABLE TO ANYONE FOR CONSEQUENTIAL OR INCIDENTAL DAMAGES OR CLAIMS EXCEPT THOSE ACCORDED BY LAW. NO EXPRESSED WARRANTY OR IMPLIED WARRANTY IS GIVEN EXCEPT THOSE SET FORTH HEREIN. NO IMPLIED WARRANTY SHALL EXTEND BEYOND 1 YEAR FROM THE DATE OF SALE.

This warranty extends only to the original purchaser of the product and is not transferable.

Some states do not allow limitations on how long an implied warranty lasts, and some states do not allow the exclusion or limitation of incidental or consequential damages, so the above limitations or exclusion may not apply to you. This warranty gives you specific legal rights, and you may have other rights that vary from state to state.

Defective merchandise should be returned to the original point of purchase or secondly, to Magnadyne Corporation, 1111 W. Victoria Street, Compton CA 90220, or 2061 Cohen Street, Montreal, Quebec H4R 2N7. Return Authorization must be obtained before sending, or merchandise may be refused.

© Copyright 1998
Magnadyne Corporation

Free Manuals Download Website

<http://myh66.com>

<http://usermanuals.us>

<http://www.somanuals.com>

<http://www.4manuals.cc>

<http://www.manual-lib.com>

<http://www.404manual.com>

<http://www.luxmanual.com>

<http://aubethermostatmanual.com>

Golf course search by state

<http://golfingnear.com>

Email search by domain

<http://emailbydomain.com>

Auto manuals search

<http://auto.somanuals.com>

TV manuals search

<http://tv.somanuals.com>