

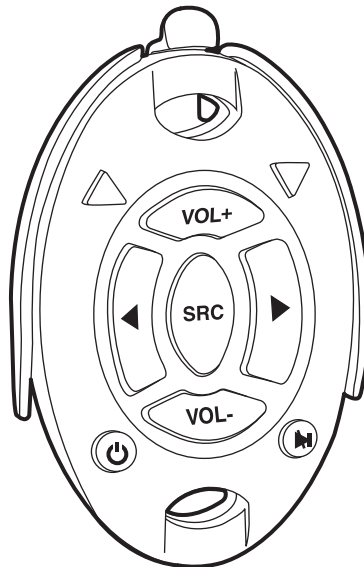

Operation and Installation Manual



MRC-2U Universal Watertight Marine Radio Controller with Speed Indicators

Index

Introduction	3
Safety Information	3
Button Locations and Functions	3
General Operations	3-4
Removing the Remote	5
Remote Installation	5
Speed-Up / Slow-Down Indicator Installation	5
Wiring Diagram	6
Learning the Radio's Remote Code	7-9
Learning an Additional Aquavibe Marine Remote Controller Code	10
Clearing All the Aquavibe Marine Remote Controller Codes	11
Warranty	12

Introduction

Please carefully read all of the information in this manual. Familiarity with operation and installation procedures will help you obtain the best possible performance from your new Marine Radio Controller.

Safety Information

DO NOT OPEN COVERS AND DO NOT REPAIR BY YOURSELF. PLEASE REFER SERVICING TO A QUALIFIED TECHNICIAN.

CHANGES OR MODIFICATIONS TO THIS PRODUCT NOT APPROVED BY THE MANUFACTURER WILL VOID THE WARRANTY AND WILL VIOLATE FCC APPROVAL.

Button Locations and Functions

- 1. Speed-Up Button:** Press to alert driver to speed up. Driver's speed-up indicator will flash twice.
- 2. Slow-Down Button:** Press to alert driver to slow down. Driver's slow-down indicator will flash twice.
- 3. Source Button (SRC):** Press to change the source/mode: Radio, CD and Auxiliary Input. Depending on what other input sources are connected (IPOD, Sirius, USB or CD Changer) these sources will also be available for selection.
- 4. Tune/Track Buttons:**
 - Radio:** Press either button and the tuner will scan to the next strong station and stop.
 - Note:** Depending on the radio, the tuner may only move to the next frequency digit instead of scanning to the next strong stations. Refer to the radio's manual for more information.
 - CD Mode:** Press to change to a lower or higher track.
- 5. Volume Control:** Press the **VOL+** button to increase the volume level and press the **VOL-** button to decrease the volume level.
- 6. Power On/Off Button:** Press to turn the unit on or off.
- 7. Mute Button:** Press to mute the volume level. Press again to restore.

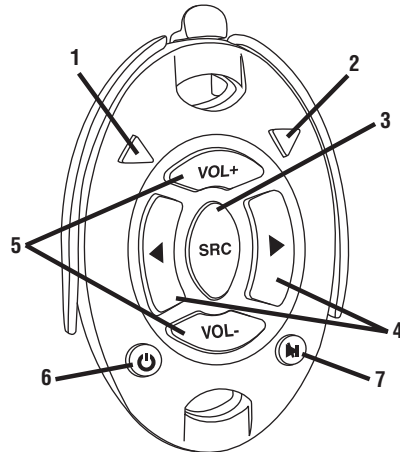

General Operations

Power On/Off:

Press the  button to turn the unit on or off.

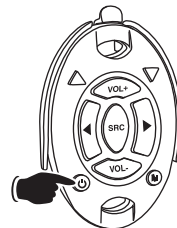

General Operations

Selecting a Source/Mode:

To select a play source, press the **SRC** button until the desired source/mode is selected.

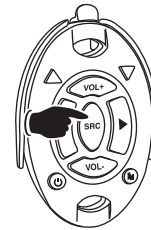

Volume:

Increase the volume by pressing the **VOL+** button.
Decrease the volume by pressing the **VOL-** button.

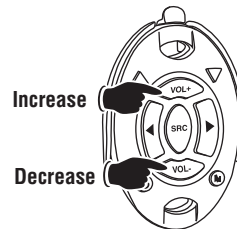

Mute:

Press the  button to mute the volume level. If a CD is playing, the  button will pause the disc. Press the  button again to restore the volume or resume playing the disc.

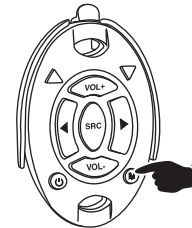



Tuning in a Radio Station Using Seek:

Press either button and the tuner will scan up to the next strong station, stop seeking and start playing.

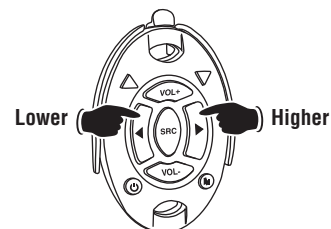
Note: Depending on the radio setting the tuner may move to the next frequency digit. Refer to the radio's manual for more information.



Track Selection:

Press the  button to select a lower track.
Press the  button to select a higher track.

Speed-Up and Slow-Down Button:

Press the **Green** arrow button to illuminate the driver's green speed-up indicator.

Press the **Red** arrow button to illuminate the driver's red slow-down indicator.

Note: Pressing either the Red or Green arrow button once will cause the driver's speed indicator light to flash twice.

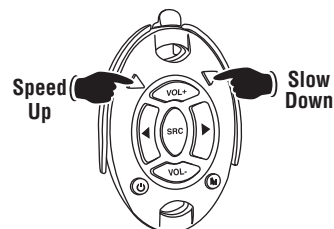

Removing the Remote

Removing the Remote from Holder:

Press the release tab and slide out the remote.
To reinstall, slide the remote into the holder until it snaps into place.

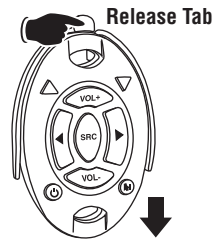

Remote Installation

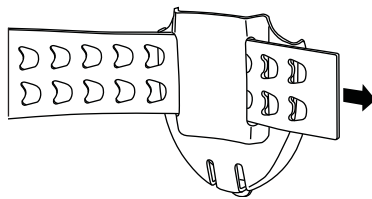

Inserting Strap:

Insert strap through the remote holder with tabs facing outward.

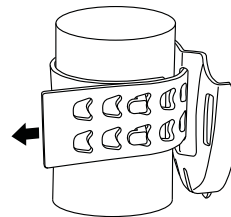

Connecting Strap:

Pull strap until the holes line up with the corresponding tabs to reach desired tension.

Speed-Up / Slow-Down Indicator Installation

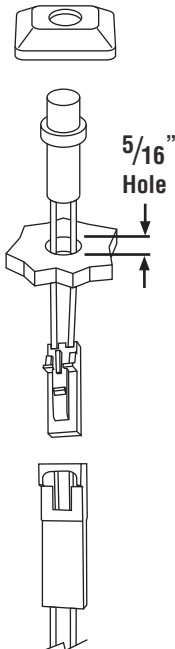

1. Find a desired location that is clearly visible to the driver.
2. Before installing the speed indicators, verify that there are no obstructions behind the location that could be damaged during installation.
3. Drill a 5/16" hole in the desired locations.
4. Feed the connector of the indicator cable through the hole until the LED is securely fastened.
5. Remove the backing from the indicator cover and attach the cover to the corresponding indicator.

Green Indicator = Speed-Up

Red Indicator = Slow-Down

Wiring Diagram

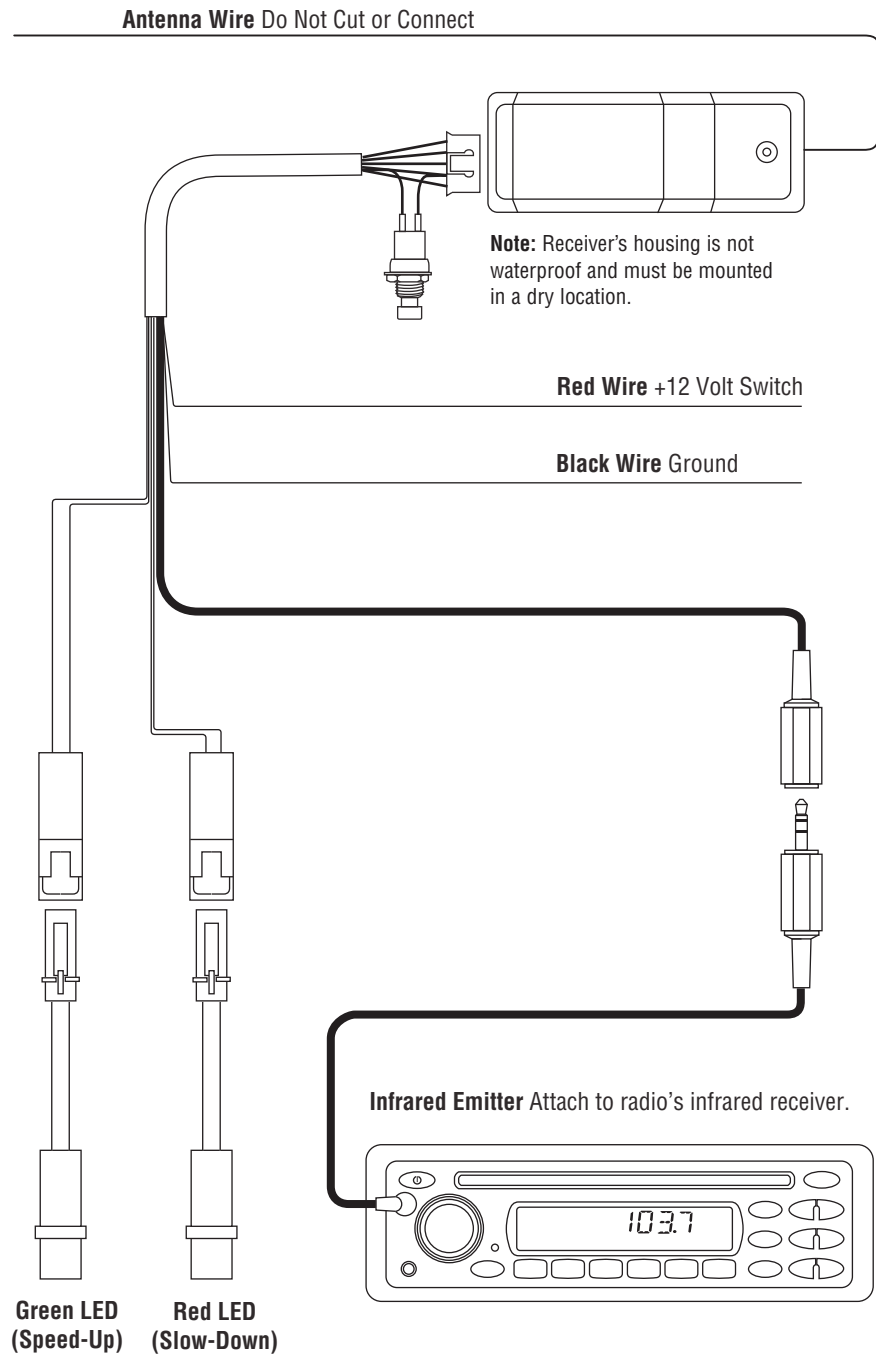

Learning the Radio's Remote Code

First, see if your radio is in the Manufacturer's Code Look-Up Table below. If your radio is listed in the table go to "Automatic Code Learning". If you can not find your radio in the list go to "Manual Code Learning".

Note: This receiver will only retain the one Radio Remote Code.

Manufacturer's Code Look-Up Table			
Manufacturer	Group	Sub-Group	Radio
Alpine, JVC, Pioneer	1	1	Alpine
		2	JVC
		3	Pioneer
MobileVision, MB Quart, Kenwood	2	1	MobileVision and MB Quart
		2	Kenwood
Sony	3	1	Sony

Automatic Code Learning

Step 1

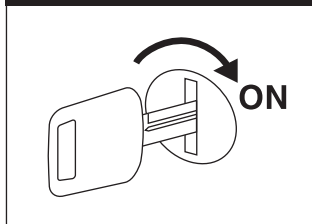

Turn on the power to the receiver's housing.

Step 2

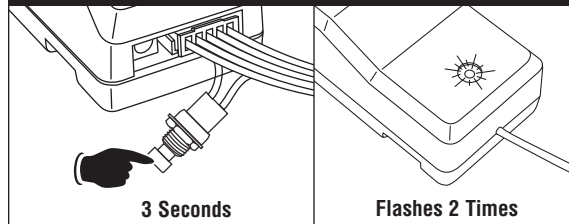

Press and hold the button on the receiver for **3** seconds. The LED on the receiver will flash **2** times and then turn off. Release the switch. You are now in "Automatic Code Learning" mode.

Step 3

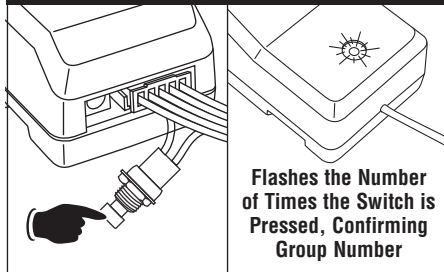

Press the switch on/off the number of times according to the radio manufacturer's **Group** number listed in the Manufacturer's Code Look-Up Table.

The LED will flash the number of times confirming the manufacturer's group selected.

Step 4

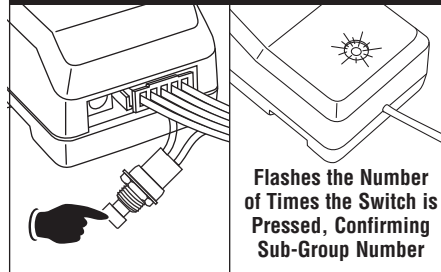

Press the switch on/off the number of times according to the radio manufacturer's **Sub-Group** number listed in the Manufacturer's Code Look-Up Table.

The LED will flash the number of times confirming the manufacturer's sub-group selected.

Automatic Code Learning (continued)

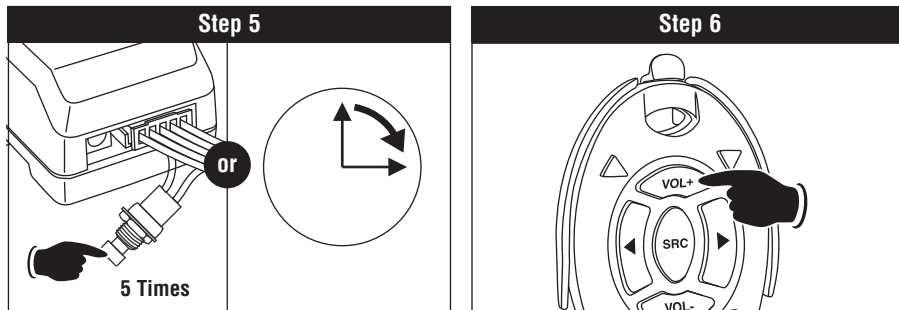

To exit programming push the switch on/off 5 times or wait 15 seconds and the system will automatically exit the "Automatic Code Learning" mode.

Try each button on the remote to make sure each button has been learned properly. If the remote does not function properly proceed to "Manual Code Learning" section below.

Manual Code Learning

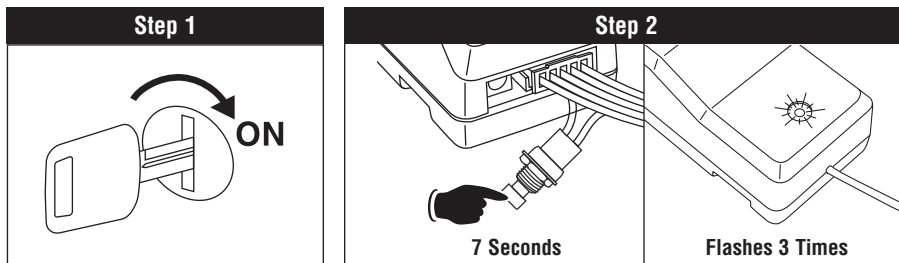

Turn on the power to the receiver's housing.

Press and hold the button on the receiver for 7 seconds. The LED on the receiver will flash 3 times and then turn off. Release the switch. You are now in "Manual Code Learning" mode

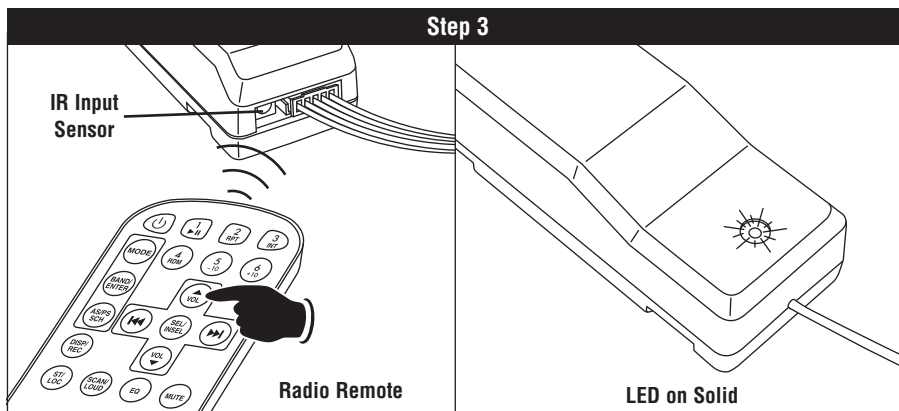

Within 15 seconds, aim the radio remote at the IR input sensor and push the "VOLUME UP" button on the radio remote.

The LED will light up solid when the code has been copied.

Manual Code Learning (continued)

Step 4

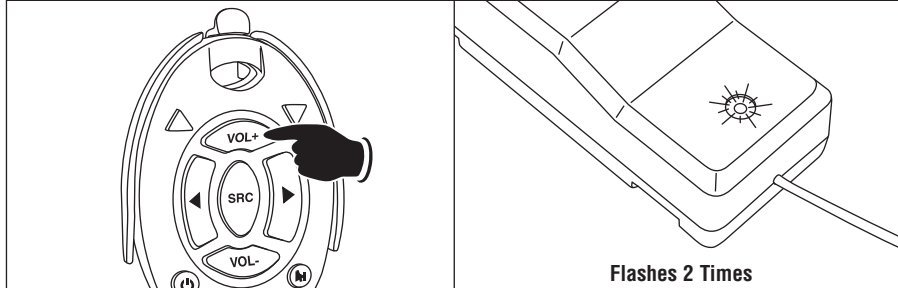

Using the RF Marine Remote press the corresponding "VOLUME UP" button to assign this function.

The LED will flash 2 times indicating the "VOLUME UP" button of the radio remote has been programmed. The LED will then turn off and is now ready for the next button to be programmed.

Step 5

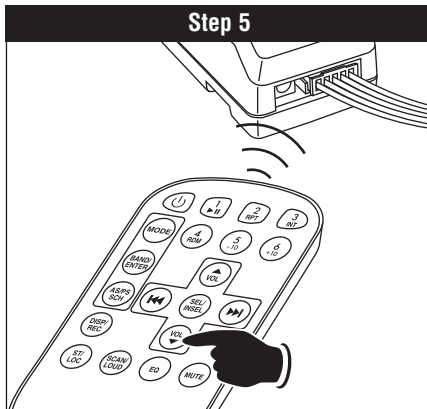

Repeat Step 3 and 4 for the remaining 7 buttons. Each button has a unique LED flash indicator confirming when they have been programmed.

Step 6

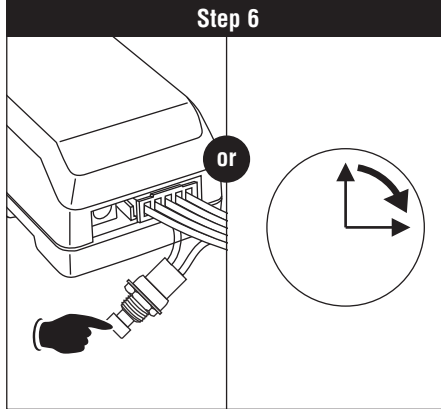

To exit programming push the switch on/off 3 times or wait 15 seconds and the system will automatically exit the "Manual Code Learning" mode.

Power On/Off Button	= 1 Flash
Volume Up Button	= 2 Flashes
Volume Down Button	= 2 Flashes
Seek Up Button	= 3 Flashes
Seek Down Button	= 4 Flashes
Mode/SRC Button	= 5 Flashes
Mute Button	= 6 Flashes

Learning an Additional Aquavibe Marine Remote Controller Code

The Aquavibe Marine Remote Controller is already pre-programmed to the receiver. No programming is necessary. If you want to program additional Aquavibe Marine Remote Controllers follow the instructions below.

Note: This receiver will only retain the 4 Marine Remote Controller codes. If the receiver's memory is exceeded, the receiver will start deleting transmitters codes from memory in chronological order.

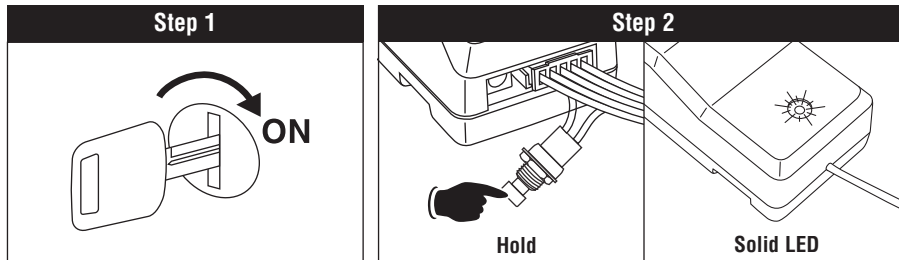

Turn on the power to the receiver's housing.

Press and hold the button on the receiver until the LED turns on solid.

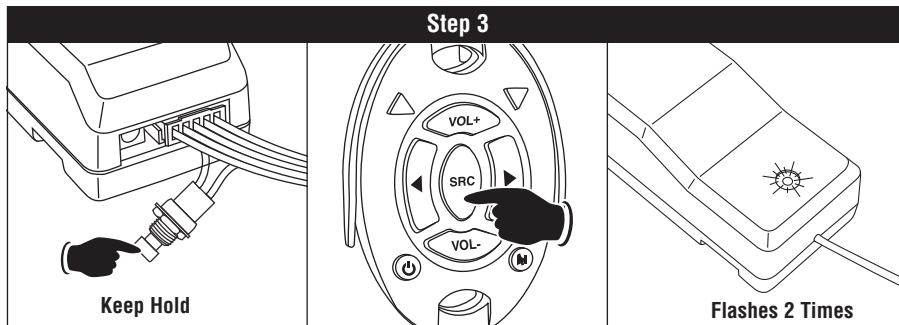

While still pressing the button on the receiver, press and release the SRC button on the remote until the LED on the receiver flashes 2 times, indicating the code is learned.

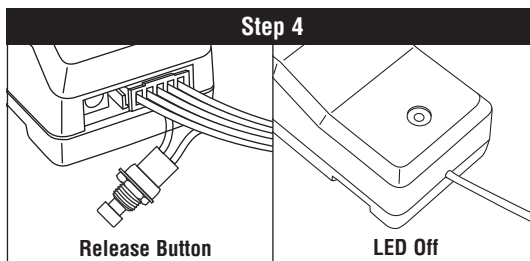

Release the receiver's button and the LED will turn off. Repeat Steps 2-4 to program additional remotes.

Note: Up to 4 remotes can be programmed.

Clearing All the Aquavibe Marine Remote Controller Codes

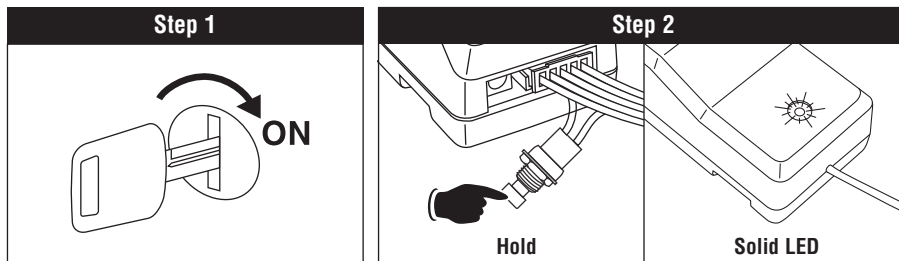

Turn on the power to the receiver's housing.

Press and hold the button on the receiver until the LED turns on solid then release button.

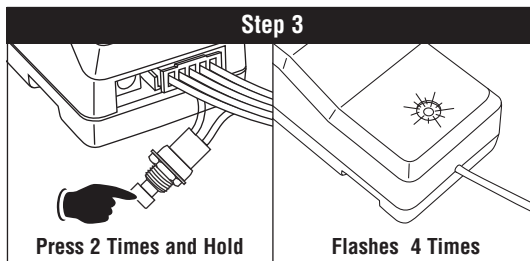

Push the receiver button 2 more times, holding on the last push. The LED will flash 4 times indicating that all remote codes are cleared.

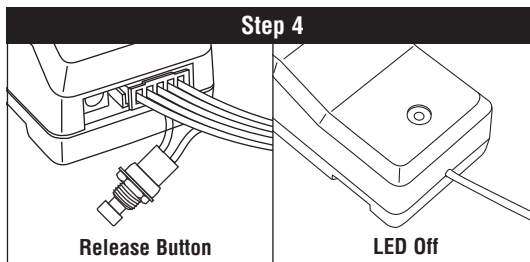

Release the receiver's button and the LED will turn off.

Warranty

ONE (1) YEAR LIMITED WARRANTY

Magnadyne Corporation or its authorized agents will within one year from the date of sale to you, repair, replace or refund the retail sales price of said product or any part thereof, at the option of the Magnadyne Corporation or its authorized agents, if said product or part is found defective in materials or workmanship, when properly connected and operating on the correct power requirements designated for the specific product. This warranty and Magnadyne Corporation or its authorized agent's obligations hereunder do not apply where the product was; damaged while in the possession of the consumer, subjected to unreasonable or unintended use, not reasonably maintained, utilized in commercial or industrial operations, or serviced by anyone other than Magnadyne Corporation or its authorized agents, or where the warning seal on the product is broken or the power and/or plugs are detached from the unit. Magnadyne Corporation or any of its authorized agents will not assume any labor costs for the removal and reinstallation of any product found to be defective, or the cost of transportation to Magnadyne Corporation or its authorized agents. Such cost are the sole responsibility of the purchaser.

This warranty does not cover the cabinet appearance items or accessories used in connection with this product, or any damage to recording or recording tape, or any damage to the products resulting from improper installation, alteration, accident, misuse, abuse or acts of nature.

MAGNADYNE CORPORATION OR ITS AUTHORIZED AGENTS SHALL NOT BE LIABLE TO ANYONE FOR CONSEQUENTIAL OR INCIDENTAL DAMAGES OR CLAIMS EXCEPT THOSE ACCORDED BY LAW. NO EXPRESSED WARRANTY OR IMPLIED WARRANTY IS GIVEN EXCEPT THOSE SET FORTH HEREIN. NO IMPLIED WARRANTY SHALL EXTEND BEYOND ONE YEAR FROM THE DATE OF SALE.

This warranty extends only to the original purchaser of the product and is not transferable. Some states do not allow limitations on how long an implied warranty lasts, and some states do not allow the exclusion or limitation of incidental or consequential damages, so the above limitations or exclusion may not apply to you. This warranty gives you specific legal rights, and you may have other rights that vary from state to state.

“NOTE: The manufacturer is not responsible for any radio or TV interference caused by unauthorized modifications to this equipment. Such modifications could void the User's authority to operate the equipment.”

Defective merchandise should be returned to the original point of purchase or secondly, to Magnadyne Corporation, 1111 W. Victoria Street, Compton CA 90220.

Return Authorization must be obtained before sending, or merchandise may be refused.

Free Manuals Download Website

<http://myh66.com>

<http://usermanuals.us>

<http://www.somanuals.com>

<http://www.4manuals.cc>

<http://www.manual-lib.com>

<http://www.404manual.com>

<http://www.luxmanual.com>

<http://aubethermostatmanual.com>

Golf course search by state

<http://golfingnear.com>

Email search by domain

<http://emailbydomain.com>

Auto manuals search

<http://auto.somanuals.com>

TV manuals search

<http://tv.somanuals.com>