

# Installation and Operations Manual

---

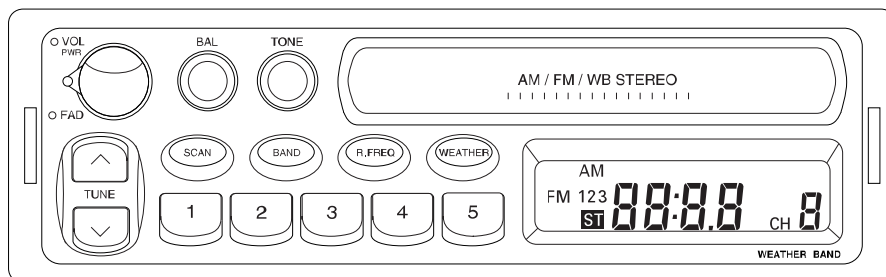

**M9800 AM/FM/WB Stereo Receiver**

## Introduction

Your new AM/FM unit incorporates a microcomputer managed electronic AM/FM stereo tuning system and FM Optimizer. The two as a combination will provide the user with the finest crystal clear AM/FM stereo radio broadcast reproduction.

To insure trouble free long term performance from your new unit, please take a moment to read this manual completely to make yourself aware of all basic radio operation and memory setting procedures.

Also at this time, it would be a good idea to write down the serial number of the unit in the space provided. In the unlikely event that the radio will need warranty service, you will need this number to obtain the service.

Serial # \_\_\_\_\_

## Mechanical Installation

### Space Requirements:

To mount your new AM/FM unit, you will need a rectangle hole in the mounting location 182mm (width) x 53mm (height), (7 $\frac{1}{8}$ " x 2 $\frac{1}{8}$ ") and a full 6" of unobstructed space behind the mounting location.

### Step 1:

After obtaining the required space and mounting hole dimensions required, release the mounting sleeve from the unit. Insert the mounting sleeve into the hole on the dashboard. Secure it by bending the tabs inward as shown in fig 1. Select the appropriate tab according to the thickness of the dashboard.

### Step 2:

Bring the power, ground, antenna and speaker wires through the center of the mounting sleeve. Make all the speaker and power connections to the main harness supplied with the unit. Refer to the "wiring" section of this unit for proper connection. After

all the connections have been made and are correct, plug the harness and the antenna cable into the mating plugs located on the rear of the unit.

### Step 3:

Turn on the ignition key and do a pre-installation check of all the functions with the unit out of the dashboard to make sure that everything is operating properly before final installation.

### Step 4:

Securely attach the rear support strap provided to the rear of the unit with the fasteners provided. Bend the strap to allow the unit to slide into its mounting sleeve. Reach up behind the unit and grab the strap while sliding the unit into the mounting sleeve until it snaps into place. Secure the end of the strap to a solid portion of the dashboard structure or the fire wall.

## Installation Procedure

### Removing the Unit:

---

In the event that the unit requires removal from its mounting location, repeat the following procedures.

- A. Release the rear support strap.
- B. Insert the keys provided into the slot on both sides of the chassis until locked. (snapped into place)
- C. Pull on the keys with equal pressure to release and remove the unit from the mounting sleeve.
- D. Disconnect the wire harness and the antenna.

### Wiring:

---

**Note 1:** If you are installing a completely new system, install all of the speakers and antenna first, then run the wires up to the radio mounting location and bring them through the radio mounting hole.

**Note 2:** Your new AM/FM unit has been designed to operate properly when connected to a "12 Volt Negative Ground" electrical system. Any other power supply may not be acceptable. Connecting your new unit to other than the specified power source will damage the unit and will void the warranty. If you are not sure that your vehicle uses a "12 Volt Negative Ground" electrical system, contact your local car stereo installation center and find out before making any connections.

### Red Wire:

---

Connect the red wire to a source of 12 volts that is controlled by the ignition key. Use a test light or volt meter to locate a connection point at the fuse block.

### Black Wire:

---

Connect the black wire to the frame of the vehicle. It is strongly recommended that the black wire be connected to a part of the vehicles frame, floorboard or sub structure to insure a good ground. It is Not advised to connect the black wire to a factory provided ground wire as it is possible that many other electrical items will be connected to this wire and electrical noises such as pops and clicks could be present in your speakers. In addition, shared grounds tend to amplify engine noise into the unit and you will hear the noise in your speakers.

### Orange Wire: (with fuse holder)

---

Connect the orange wire to a constant source of 12 volts. The battery portion of the fuse block is a good location for this wire. Use a test light or volt meter to locate a connection point at the fuse block.

# Installation Procedure

Figure 1

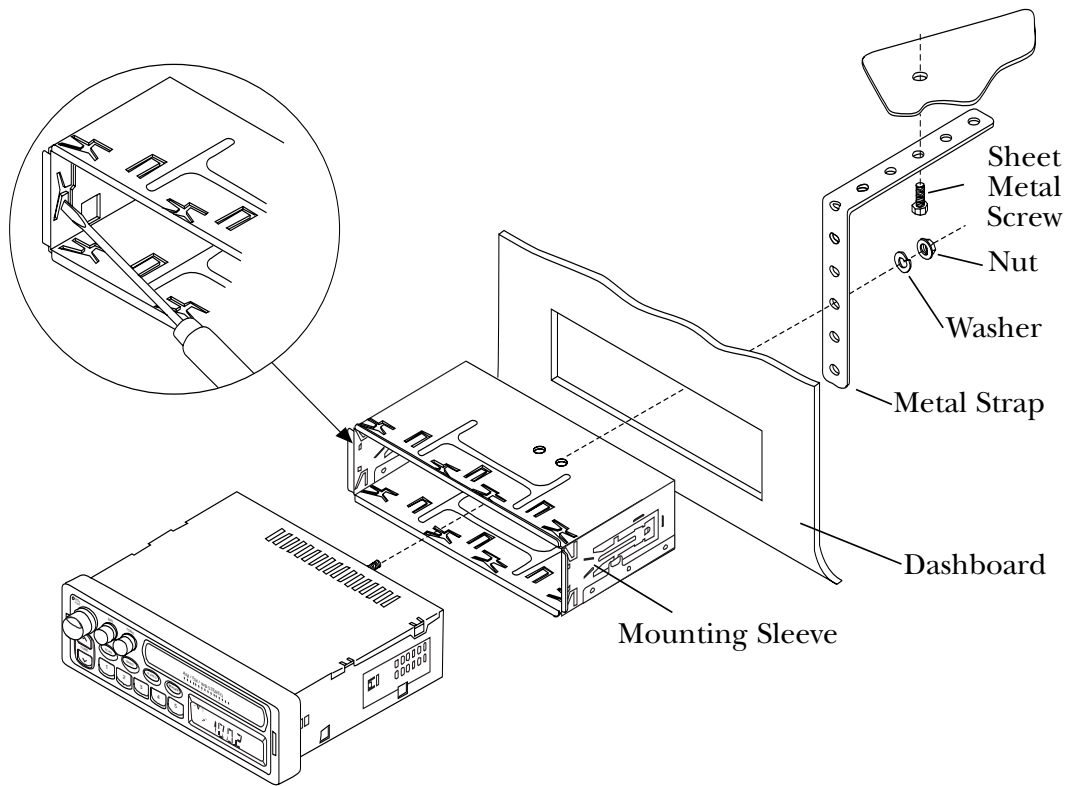

## Removing the Unit

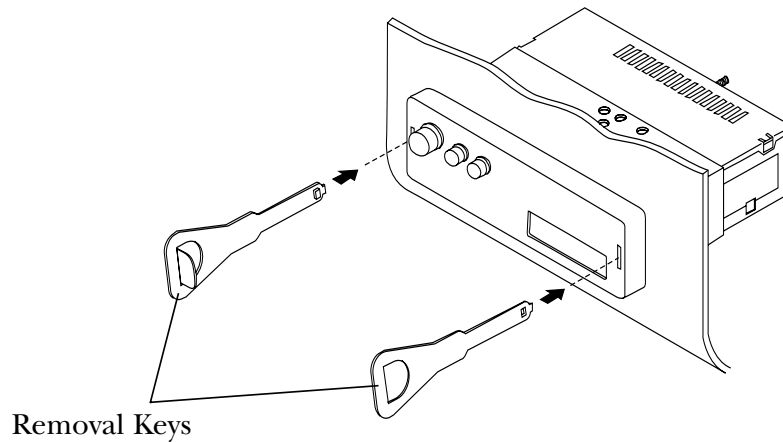

## Installation Procedure

### Speaker Connections:

**Note:** Every speaker has a positive (+) and a negative (-) connection terminal, therefore every speaker must have two wires connected to it. To properly connect the speaker system to your new Magnadyne radio, you must have a + and - wire coming from every speaker to connect to the unit. If you are connecting 2 speakers, you should have 4 wires to connect. If you are connecting 4 speakers, you should have 8 wires to connect.

### Wiring Four Speakers:

(Fader Control Operational)

#### Green Wire:

Connect the Green wire to the Left Front speaker "Positive" wire.

#### Green/Black Wire:

Connect the Green/Black wire to the Left Front speaker "Negative" wire.

#### Green/Red Wire:

Connect the Green/Red wire to the Left Rear speaker "Positive" wire.

#### Black/Green Wire:

Connect the Black/Green wire to the Left Rear speaker "Negative" wire.

#### Gray Wire:

Connect the Gray wire to Right Front speaker "Positive" wire.

#### Gray/Black Wire:

Connect the Gray/Black wire to the Right Front speaker "Negative" wire.

#### Gray/Red Wire:

Connect the Gray/Red wire to the Right Rear speaker "Positive" wire.

#### Black/Gray Wire:

Connect the Black/Gray wire to the Right Rear speaker "Negative" wire.

### Wiring Two Speakers:

#### Green Wire:

Connect the Green wire to the Left speaker "Positive" wire.

#### Black/Green Wire:

Connect the Black/Green wire to the Left speaker "Negative" wire.

#### Gray Wire:

Connect the Gray wire to the Right speaker "Positive" wire.

#### Black/Gray Wire:

Connect the Black/Gray wire to the Right speaker "Negative" wire.

### Warning !

1. Do Not Ground any speakers to the frame of the vehicle or to any other grounding system other than the wires provided in the harness.
2. When the 2 speaker wiring is followed, the fader control of the unit is non-functional

# Installation Procedure

## Four Speaker Wiring

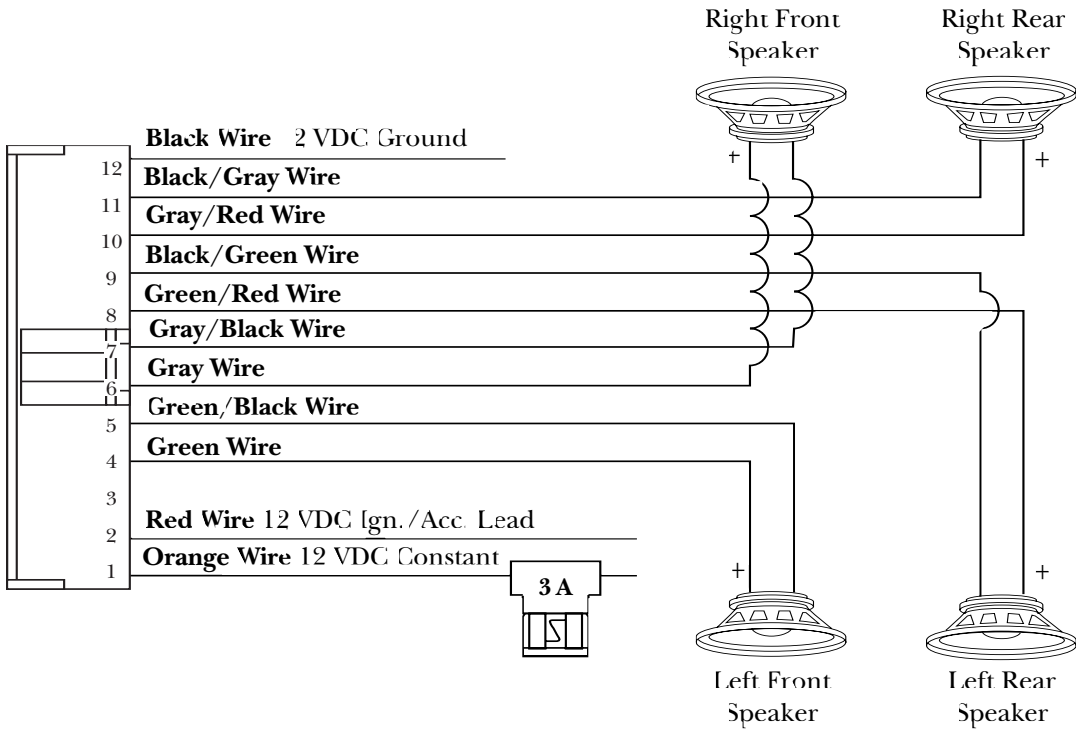

## Two Speaker Wiring

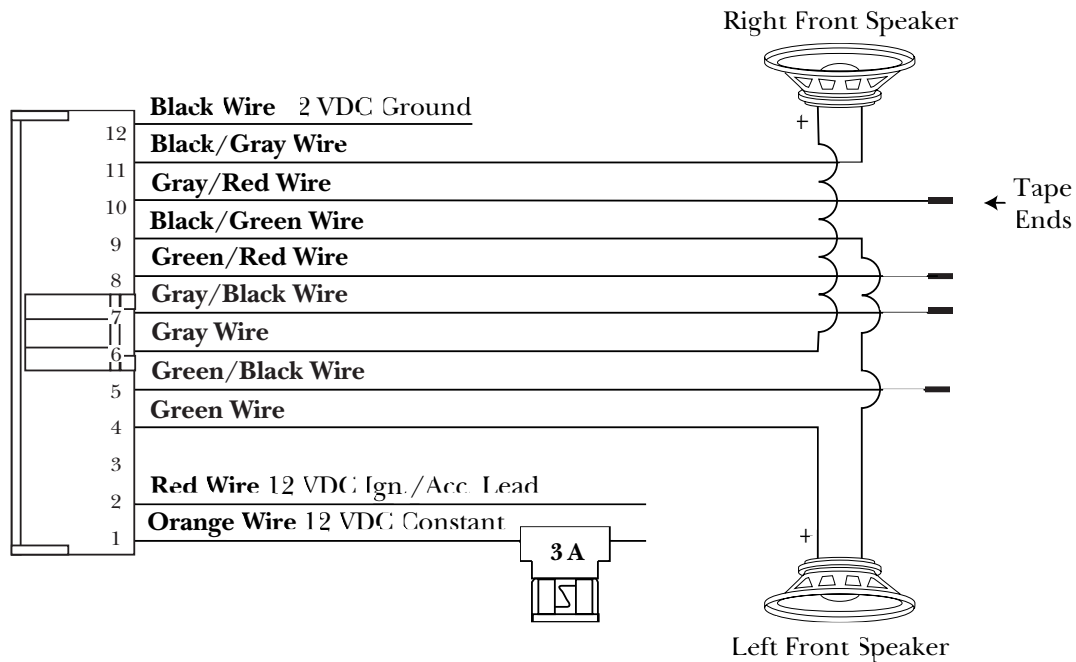

## Control Button Identification

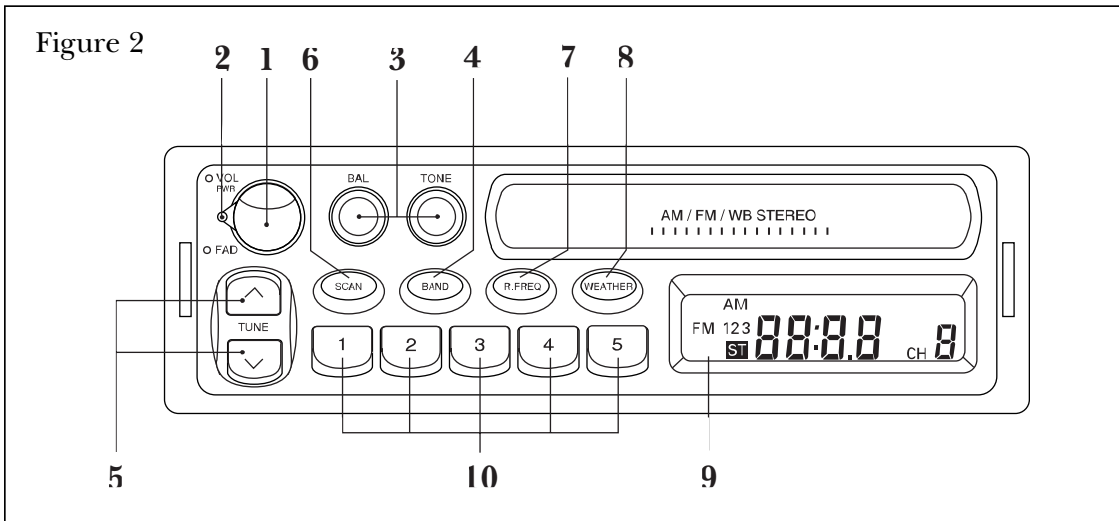

1. On/Off Power Switch, Control and Volume Level Adjuster.
2. Fader Control.
3. Balance and Tone Controls.
4. Radio Band Selector Button.
5. Manual Tuning Control Buttons.
6. Radio Station Scan Button.
7. Frequency Selector Button.
8. Weatherband Radio Selector Switch.
9. Display.
10. Preset Stations.

## Display

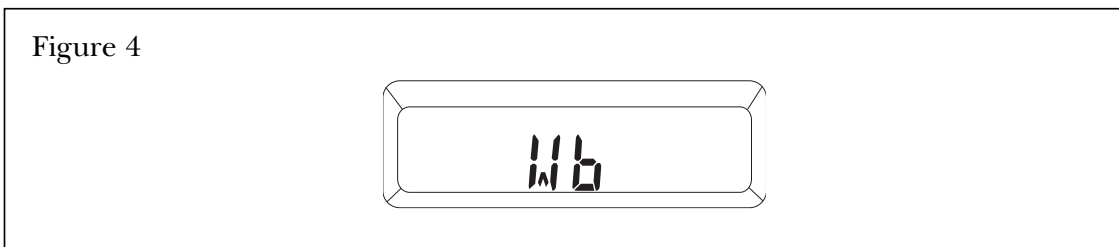
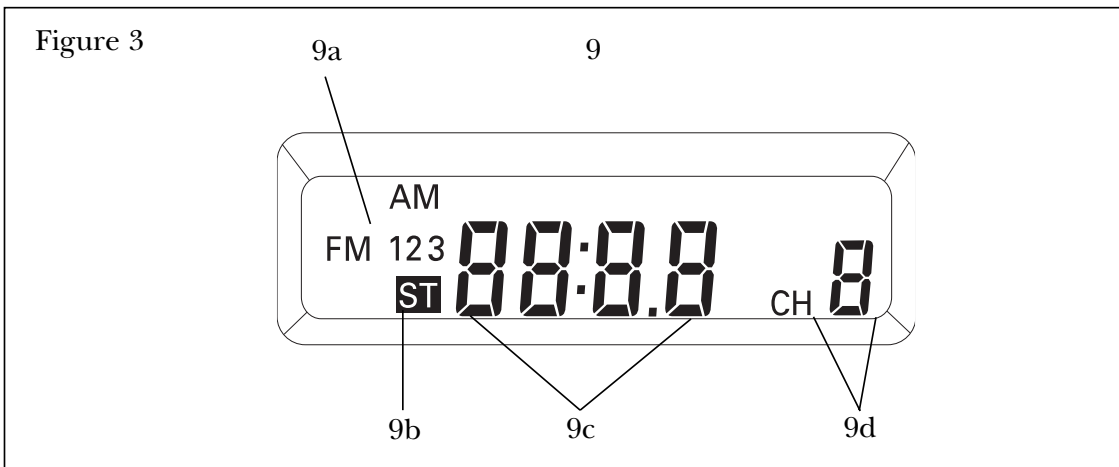

## Using the Radio

### Listening to the Radio:

1. Turn the vehicle's ignition key to the "ON" or "ACC" position to provide power to the radio.
2. Rotate knob (1) clockwise to turn the radio on. Adjust the volume knob (1) to a low listening level.
3. Use the band button (4) to select the AM or FM radio band. The FM band has 3 banks (FM1, 2, and 3). The AM band has 2 banks (AM 1 and 2)
4. Use the tuning button (5) to select a desired radio station. Press the "Λ" (up) button to tune to higher radio stations. Use the "∇" (down) button to tune to lower radio stations. Pressing and releasing the tuning control buttons (5) will cause the tuner to move up or down two decimal increments. Pressing and holding the up or down tuning buttons (5) will cause the tuner to count up or down at high speed.
5. If you are traveling in an area where you are not familiar with the local radio stations, press and release the scan button (6). This will activate the auto tuning system and the tuner will scan up to the next available strong station and stop for 5 seconds. After 5 seconds has passed, the tuner will search up to the next strongest station and stop. If you find a station to your liking, simply press and release the scan button once again to stop the scan operation.
6. Adjust the tone, fader, balance and volume controls as needed using the information "Audio adjustments" section of this manual.

### Display Priority Note:

The priority of the display area (9) is for the clock. 5 seconds after the last tuning control command, the display will change and display the clock. To recall the radio frequency, press and release the "R.Freq" button (7). The display will change to show the radio frequency then will revert back to the clock after 5 seconds.

### Listening to the Weatherband Radio

1. At any time when the AM/FM radio is playing, you can press the "Weather" button (8). The automatic weatherband seek tuning will begin to find the strongest broadcast frequency in the area you are traveling in. When the weatherband radio is activated "WB" will appear in the display area (9c) figure 4. Once the tuner has locked on to a station, the weatherband radio will operate.
2. To turn the weatherband radio off, press the "weather" button (8) once more and the unit will return to the signal source (AM/FM) you were previously listening to.
3. 7 weather stations are available. If you would like to scroll through the stations, press the weather button (8) to activate the weatherband and then press the "Λ" or "∇" tuning button (5) to scroll up or down the 7 stations.

**Note:** All 7 stations may not be available in the area you are traveling in.



### Setting the Clock with the Radio OFF

1. Turn the vehicles ignition key to the "ON" or "ACC" position to provide power to the radio. You will know that radio has sufficient power as the clock will be displayed in the LCD display window (9).
2. Press the 'R.FREQ' button (7) and hold it down.
3. Adjust the HOURS by pressing the "∨" (down) tuner control button (5) until the correct hour is displayed. Note: The clock is a 12 hour clock and does not indicate "AM or PM".
4. Adjust the MINUTES by pressing the "∧" (up) tuner control button (5) until the correct minutes are displayed.

### Setting the Clock with the Radio ON

1. While the radio is on, press the 'R.FREQ' button (7) to display the time. Hold the button down.
3. Adjust the HOURS by pressing the "∨" (down) tuner control button (5) until the correct hour is displayed.  
**Note:** The clock is a 12 hour clock and does not indicate "AM or PM".
4. Adjust the MINUTES by pressing the "∧" (up) tuner control button (5) until the correct minutes are displayed.

### Programming the Radio Station Recall Buttons

1. Rotate knob (1) clockwise to turn on the unit. Adjust the volume knob (1) to a normal listening level.
2. Use the band button (4) to select the AM or FM radio band you want to memorize radio stations to. The FM band has 3 banks (FM 1, 2, and 3). The AM band has 2 banks (AM 1 and 2). Continue pressing the band button (4) until the desired radio band is displayed (9a).
3. Use the tuning button (5) to select a desired radio station. Press the "∧" (up) button to tune to higher radios stations. Use the "∨" (down) button to tune to lower radio stations. Pressing and releasing the tuning control buttons (5) will cause the tuner to move up or down two decimal increments. Pressing and holding the up or down tuning buttons (5) will cause the tuner to count up or down at high speed.
4. Once the desired station is selected, press and hold down one of the 5 station recall buttons (10) until the channel indicator (9d) is displayed, release the button. The station is now memorized to the band indicated (9a) and the recall button indicated (9d). Repeat procedures 2 thru 4 for all 5 preset buttons.
5. Select another radio bank and repeat steps 2 thru 4 above to memorize all 15 FM radio stations and 10 AM radio stations.

## Audio Adjustments

### Volume Level

1. Rotate the volume control knob (1) clockwise to increase the volume.
2. Rotate the volume control knob (1) counter clockwise to decrease the volume.

### Left to Right Balance

2. Rotating the "BAL " knob (3) to the left will balance the speakers to the left.
3. Rotating the "BAL" knob (3) to the right will balance the speakers to the right.

### Front to Rear Speaker Balance

(Fader Control)

Rotate the fader control (2) clockwise or counter clockwise to adjust the speaker balance from the front of the vehicle to the rear of the vehicle.

### Tone Control

Rotate the tone control (3) from the left to the right to achieve the desired tonal quality.

### Loudness Boost

1. The loudness boost is automatic. For the first 1/2 rotation of the volume control, the loudness circuit is active and will boost up the low range (100Hz) and high range (10Khz) to compensate for the music tones that are not normally heard at low volume listening.
2. After the volume control is rotated past the 1/2 way mark, the loudness effect will diminish as at these higher volumes, the boost is not needed.

## Specifications

### AM/FM Tuner:

FM Frequency Range .. 87.5 - 107.9MHz

AM Frequency Range .. 520 - 1720 KHz

IF Rejection ..... AM 45dB  
FM 70dB

Image Rejection ..... AM 55dB  
FM 55dB

Selectivity ..... AM 30dB  
FM 60dB

S/N ratio (Signal to Noise) .. AM 48dB  
FM 65dB

Stereo Separation ..... 32dB

### General:

Power Requirements ..... 11.2V - 14.4V

DC Negative Ground

Tone Control .....  $\pm 15\text{dB}$ @ 10kHz

Speaker Impedance Requirements

4 or 8 Ohm

### Output Power:

5 Watts x 2 @ 10% THD

Weight ..... 1.8 lbs.

Features and Specifications are subject to  
change and improvement without notice.

## Warranty

### ONE (1) YEAR LIMITED WARRANTY

Magnadyne Corporation or its authorized agents will within 1 year from the date of sale to you, repair, replace or refund the retail sales price of said product or any part thereof, at the option of the Magnadyne Corporation or its authorized agents, if said product or part is found defective in materials or workmanship, when properly connected and operating on the correct power requirements designated for the specific product. This warranty and Magnadyne Corporation or its authorized agents obligations hereunder do not apply where the product was; damaged while in the possession of the consumer, subjected to unreasonable or unintended use, not reasonably maintained, utilized in commercial or industrial operations, or serviced by anyone other than Magnadyne Corporation or its authorized agents, or where the warning seal on the product is broken or the power and/or plugs are detached from the unit. Magnadyne Corporation or any of its authorized agents will not assume any labor costs for the removal and re-installation of any product found to be defective, or the cost of transportation to Magnadyne Corporation or its authorized agents. Such cost are the sole responsibility of the purchaser.

This warranty does not cover the cabinet appearance items or accessories used in connection with this product, or any damage to recording or recording tape, or any damage to the products resulting from improper installation, alteration, accident, misuse, abuse or acts of nature.

MAGNADYNE CORPORATION OR ITS AUTHORIZED AGENTS SHALL NOT BE LIABLE TO ANYONE FOR CONSEQUENTIAL OR INCIDENTAL DAMAGES OR CLAIMS EXCEPT THOSE ACCORDED BY LAW. NO EXPRESSED WARRANTY OR IMPLIED WARRANTY IS GIVEN EXCEPT THOSE SET FORTH HEREIN. NO IMPLIED WARRANTY SHALL EXTEND BEYOND 1 YEAR FROM THE DATE OF SALE.

This warranty extends only to the original purchaser of the product and is not transferable.

Some states do not allow limitations on how long an implied warranty lasts, and some states do not allow the exclusion or limitation of incidental or consequential damages, so the above limitations or exclusion may not apply to you. This warranty gives you specific legal rights, and you may have other rights that vary from state to state.

Defective merchandise should be returned to the original point of purchase or secondly, to Magnadyne Corporation, 1111 W. Victoria Street, Compton CA 90220, or 2061 Cohen Street, Montreal, Quebec H4R 2N7. Return Authorization must be obtained before sending, or merchandise may be refused.

© Copyright 1998  
Magnadyne Corporation

## Free Manuals Download Website

<http://myh66.com>

<http://usermanuals.us>

<http://www.somanuals.com>

<http://www.4manuals.cc>

<http://www.manual-lib.com>

<http://www.404manual.com>

<http://www.luxmanual.com>

<http://aubethermostatmanual.com>

Golf course search by state

<http://golfingnear.com>

Email search by domain

<http://emailbydomain.com>

Auto manuals search

<http://auto.somanuals.com>

TV manuals search

<http://tv.somanuals.com>