

TECHNICAL INFORMATION



PRODUCT

P 1/10

Model No. ▶ BHP456 (LXPH01*1)

Description ▶ Cordless Hammer Driver Drill

*1 Model number for North and Central American countries

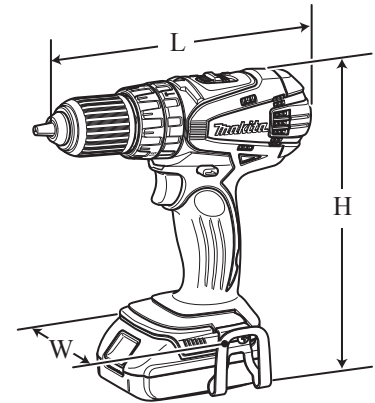

(with Battery BL1815)

CONCEPT AND MAIN APPLICATIONS

Model BHP456 (LXPH01) is the improved version of model BHP452, featuring:

- More compact and lightweight design than BHP452
- More comfortable operation will be provided by re-designed ergonomic grip
- Compatible with the 18V Li-ion batteries equipped with the Battery protection circuit designed to protect the battery from damages due to overdischarge, high temperature or overload current

This new product is available in the following variations.

Model No.	Battery		Battery cover	Charger	Plastic carrying case	Housing color
	Type	Quantity				
BHP456RHE (LXPH01C)	BL1815	2	1	DC18RA	Yes	Makita blue
BHP456RHEW (LXPH01CW)						white
BHP456RFE (LXPH01)	BL1830	2	1	DC18RA	Yes	Makita blue
BHP456RFEW (LXPH01W)						white
BHP456Z (LXPH01Z)	No	No	No	No	No	Makita blue
BHP456ZW (LXPH01ZW)						white
BHP456SHE	BL1815	2	1	DC18SD	Yes	Makita blue
BHP456SHEW						white

Dimensions: mm (")	
Length (L)	206 (8-1/8)
Width (W)	79 (3-1/8)
Height (H)	234 (9-1/4)*2
	251 (9-7/8)*3

*2: with Battery BL1815
*3: with Battery BL1830

Model number in parentheses is for North and Central American countries.
All models also include the accessories listed below in "Standard equipment".

▶ Specification

Battery	Voltage: V	18
	Capacity: Ah	1.3/ 3.0
	Cell	Li-ion
	Charging time (approx.): min.	15/ 22 with DC18RA
Max output: W		300
No load speed: min-1=rpm		Low/ High 0 - 400/ 0 - 1,500
Impacts per minute: min-1= rpm		Low/ High 0 - 6,000/ 0 - 22,500
Capacity of drill chuck: mm (")		1.5 (1/16) - 13 (1/2)
Capacity: mm (")	Steel	13 (1/2)
	Wood	38 (1-1/2)
	Masonry	13 (1/2)
Torque setting		16 stage + drill mode
Clutch torque setting: N.m (in.lbs)		1.0 - 5.0 (9 - 44)
Lock torque: N.m (in.lbs)		54 (480)
Max. fastening torque: N.m (in.lbs)	Soft joint	36 (320)
	Hard joint	50 (440)
Electric brake		Yes
Mechanical speed control		Yes (2 speed)
Variable speed control		Yes
Reversing switch		Yes
LED job light		Yes
Weight according to EPTA-Procedure 01/2003*4: kg (lbs)		1.6 (3.4)*2/ 1.8 (4.0)*3

*2: with Battery BL1815, *3: with Battery BL1830

*4 with the lightest battery available for the model

▶ Standard equipment

- + - bit 2-45 1
- Belt clip 1

Note:

The standard equipment for the tool shown above may vary by country.

▶ Optional accessories

- Fast charger DC18RA,
- Charger DC18SD,
- Charger DC24SC (for all countries except North American countries),
- Automotive Charger DC18SE,
- Battery BL1815,
- Battery BL1830,
- Drill bits for wood,
- Drill bits for steel,
- Drill bits for masonry,
- Belt clip,
- Bit holder

► Repair

CAUTION: Repair the machine in accordance with “Instruction manual” or “Safety instructions”.

[1] NECESSARY REPAIRING TOOLS

Code No.	Description	Use for
	Hex wrench 10	Removing / Assembling drill chuck
1R359	Drill chuck removing tool	Removing Drill chuck (Use this tool if Drill chuck cannot be removed by the method described in “[3]-1. Drill chuck disassembling”.)

[2] LUBRICATIONS

Lubrications are not required as Gear section is replaced as a factory-lubricated gear unit.

[3] DISASSEMBLY/ASSEMBLY

[3]-1. Drill chuck

DISASSEMBLING

(1) Set Machine and Repairing tools. (Figs. 1, 2, 3)

Fig. 1

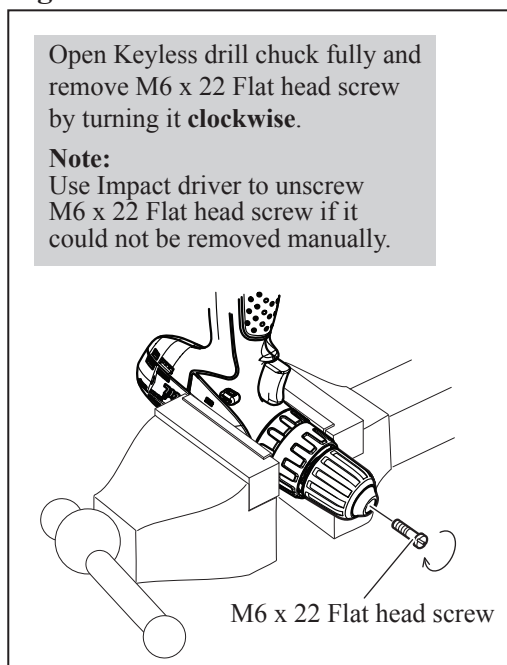

Fig. 2

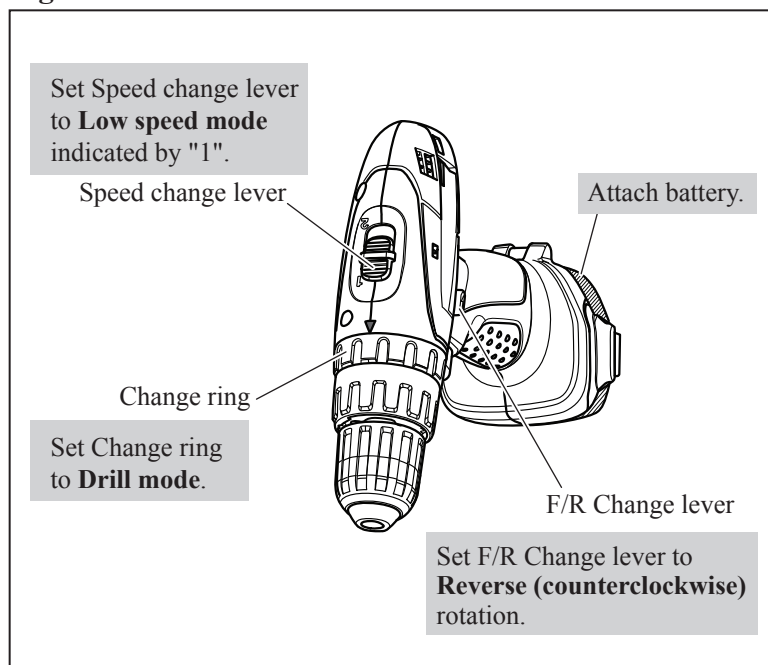
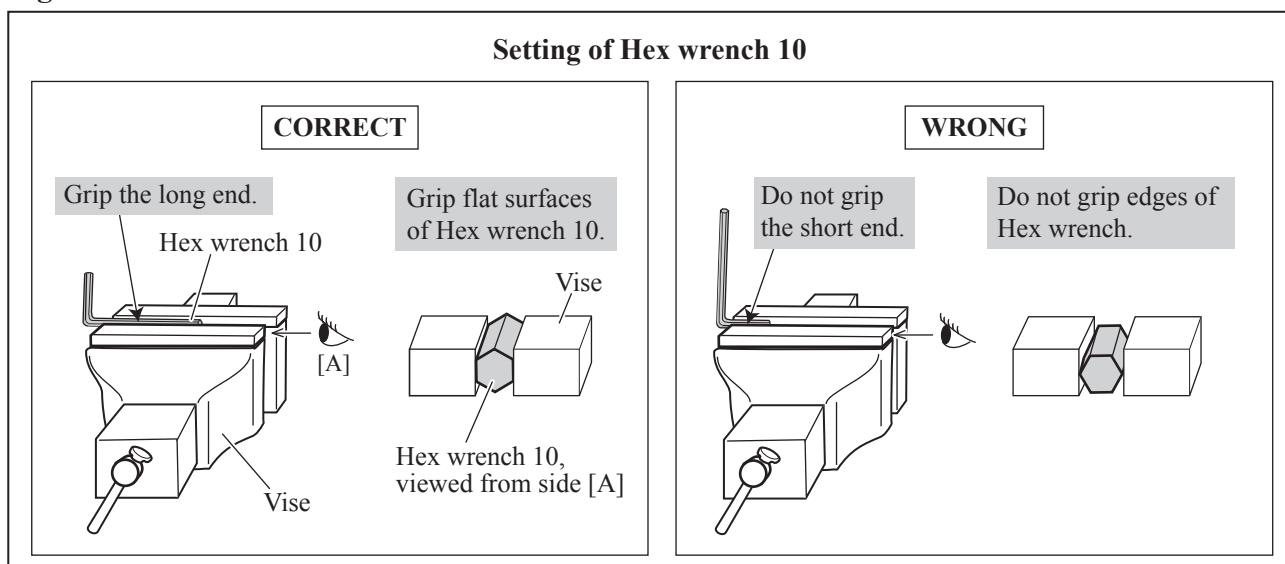

Fig. 3



► **Repair**

[3] DISASSEMBLY/ASSEMBLY

[3]-1. Drill chuck (cont.)

DISASSEMBLING

(2) Remove Drill chuck. (Fig. 4)

Fig. 4

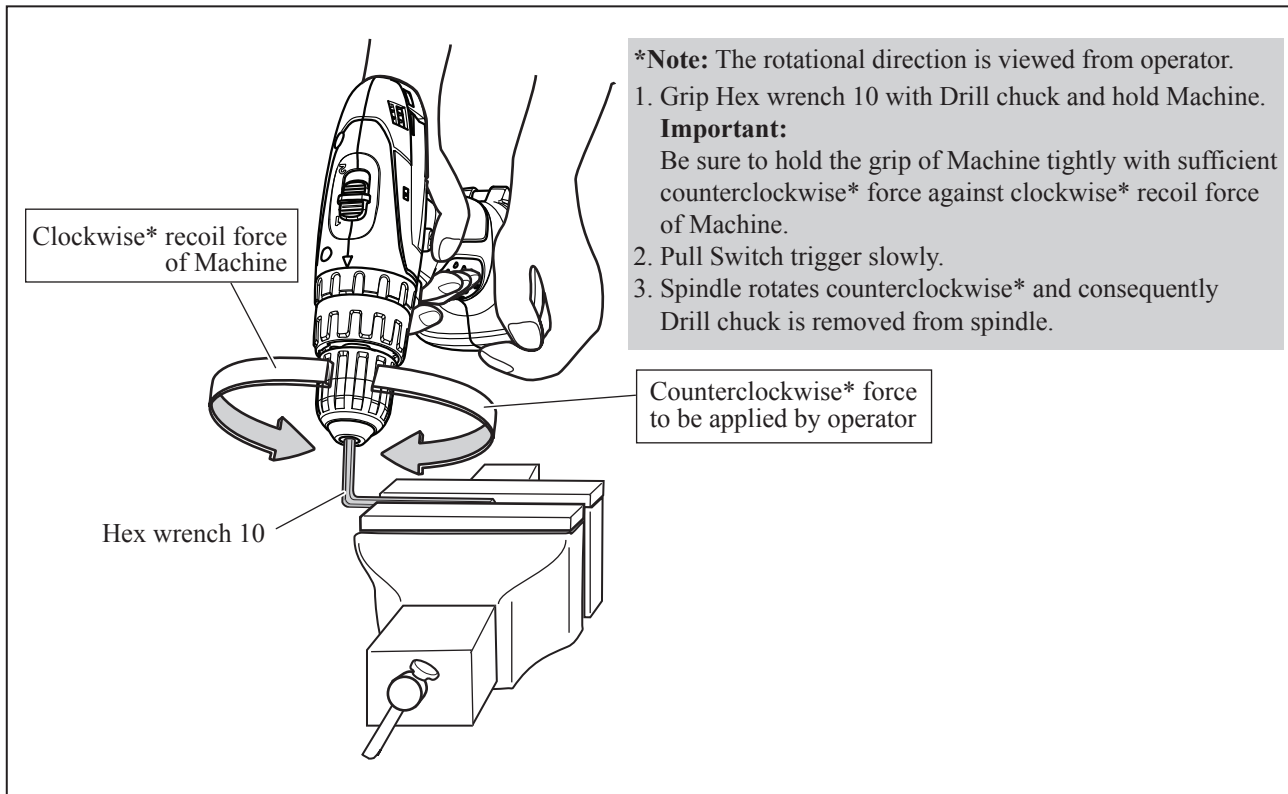

ASSEMBLING

(1) Set the machine. (Figs. 5, 6)

(2) Set Hex wrench 10 to vise as described in Fig. 3.

Fig. 5

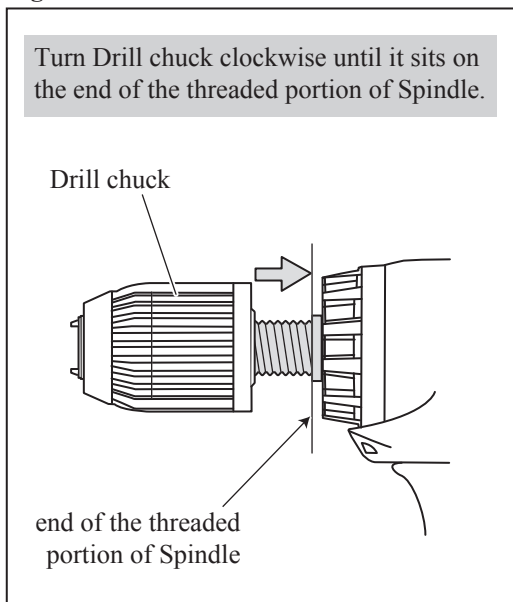
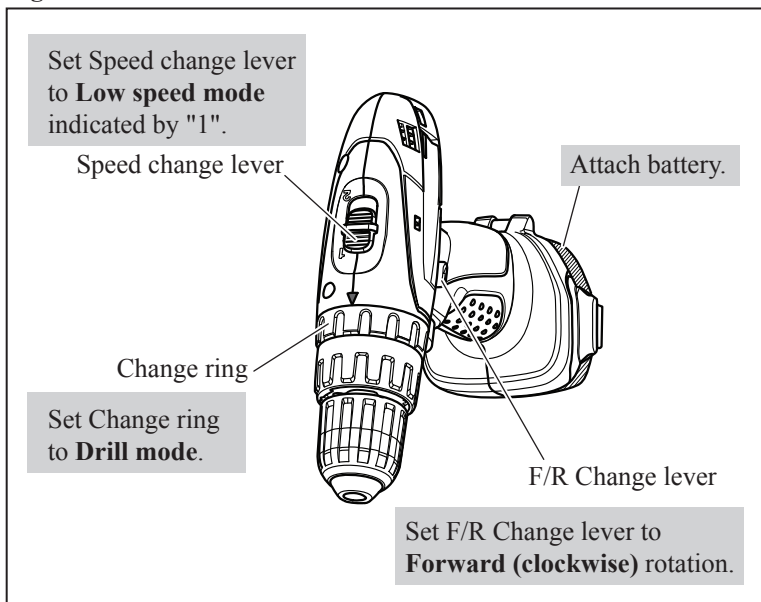

Fig. 6



► Repair

[3] DISASSEMBLY/ASSEMBLY

[3]-1. Drill chuck (cont.)

ASSEMBLING

(3) Tighten Drill chuck. (Fig. 7)

Fig. 7

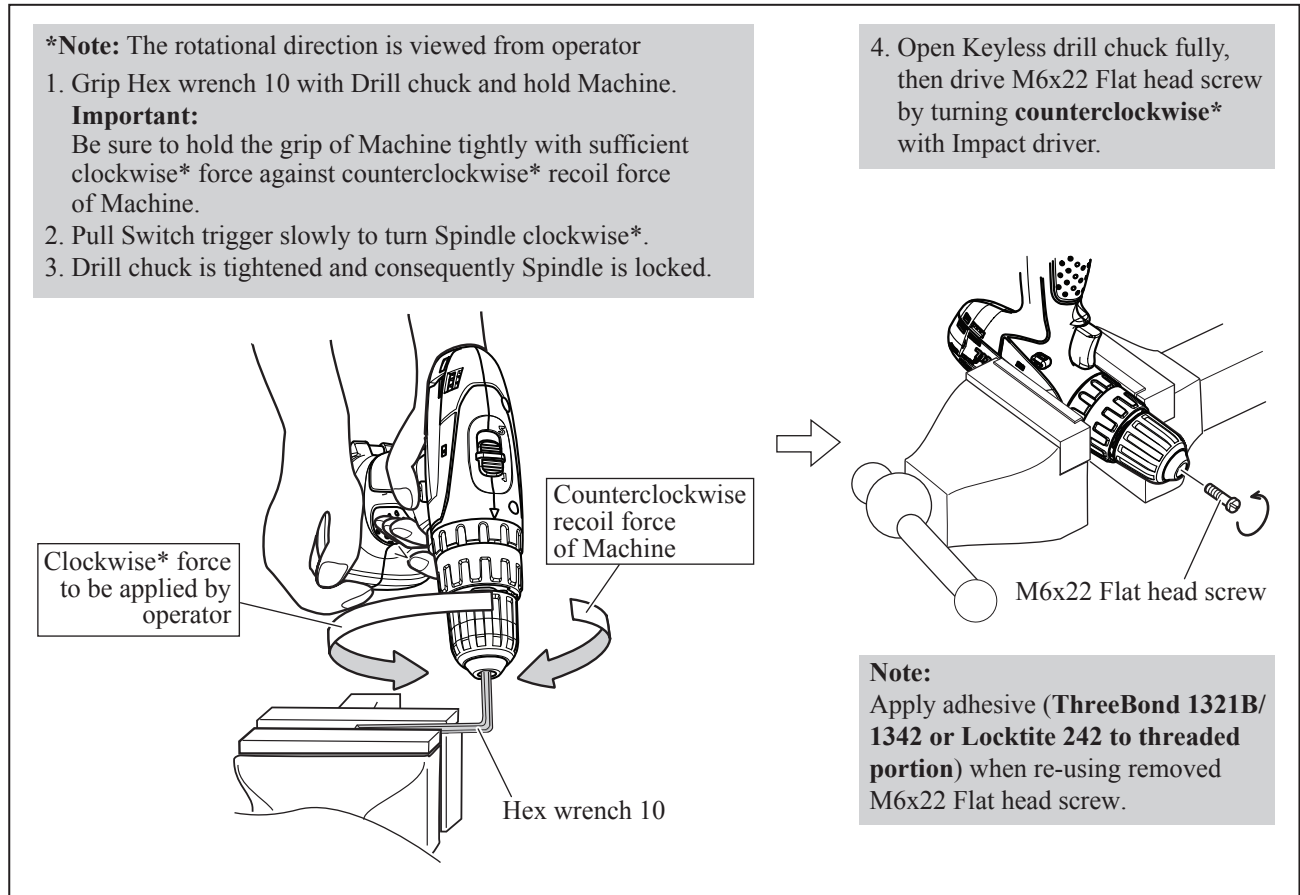

[3]-2. Gear assembly and Motor section

DISASSEMBLING

- (1) First, remove Drill chuck. (Figs. 1, 2, 3, 4)
- (2) Then remove Rear cover and disconnect Carbon brushes from Armature's Commutator before dismantling Housing set. (Fig. 8)

Fig. 8

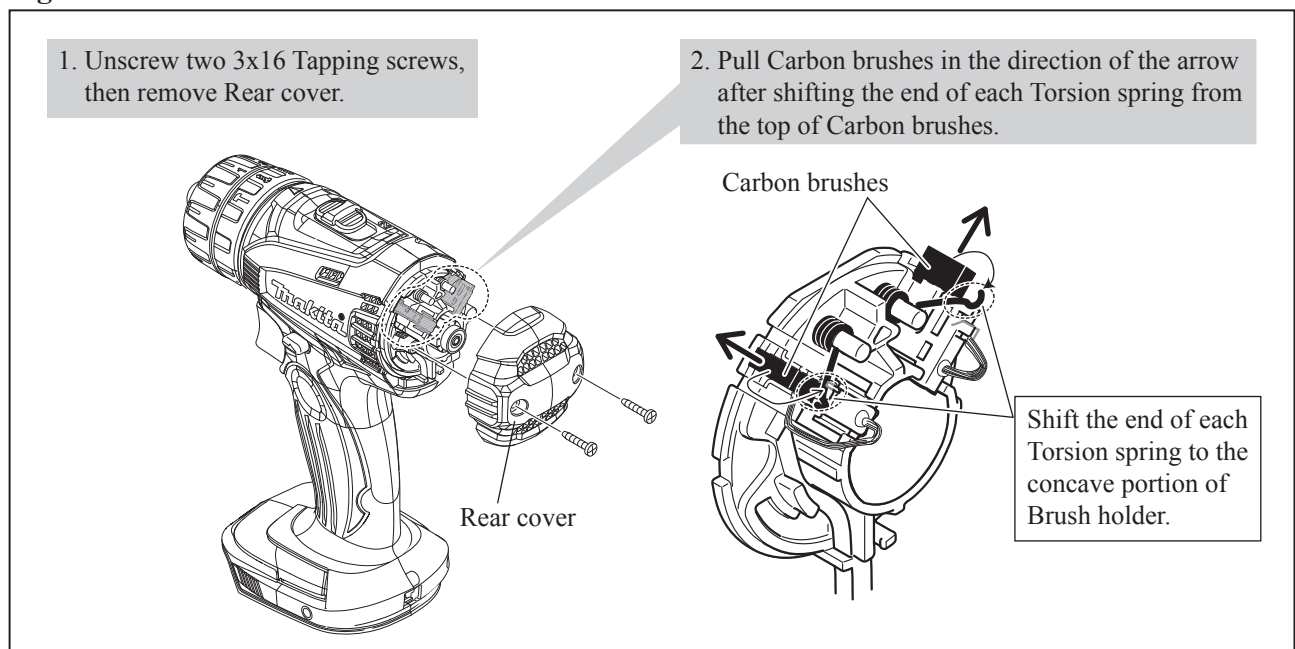

► Repair

[3] DISASSEMBLY/ASSEMBLY

[3]-2. Gear assembly and Motor section

DISASSEMBLING

(3) Disassemble Gear assembly and Motor section. (Fig. 9)

Fig. 9

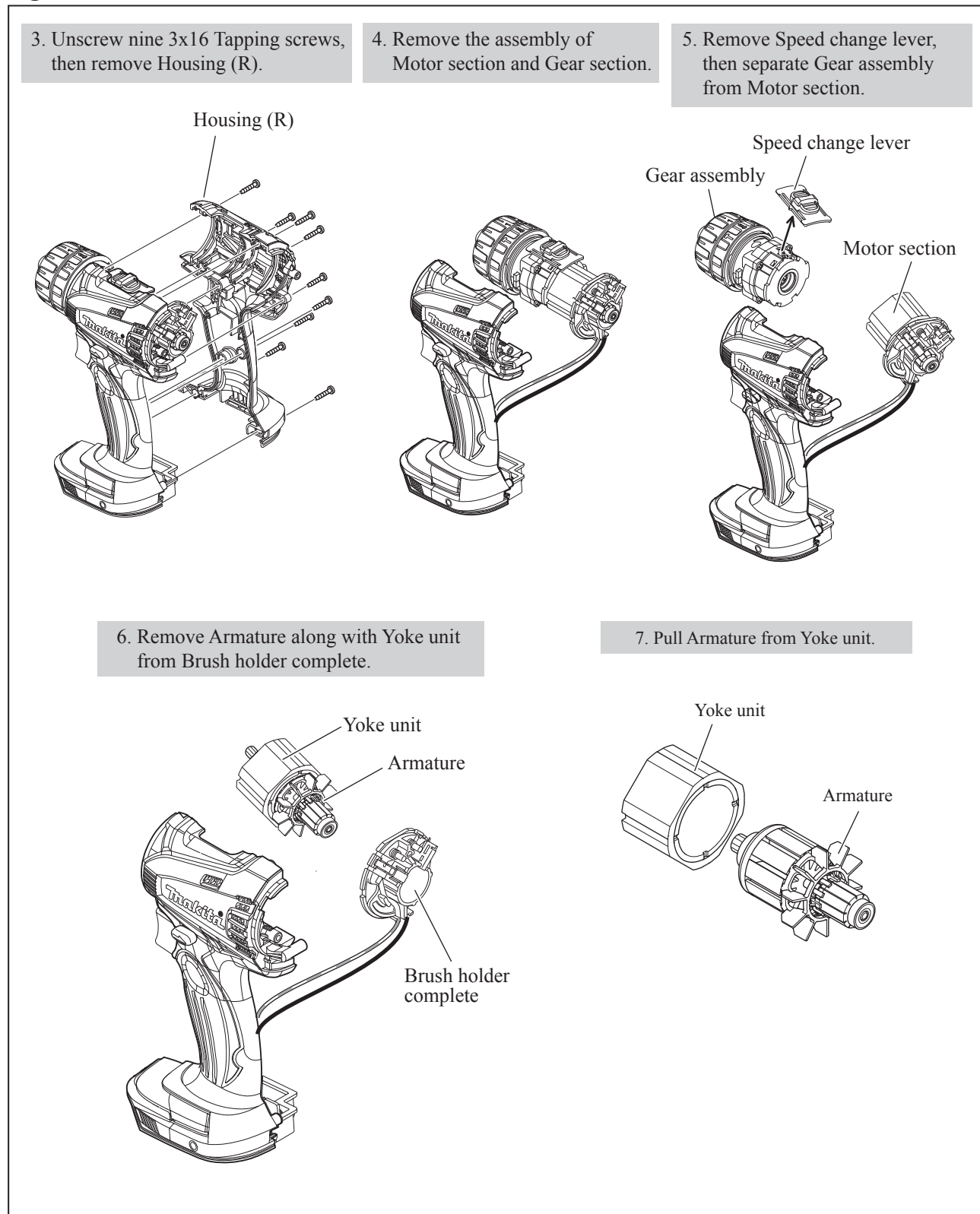

► **Repair**

[3] DISASSEMBLY/ASSEMBLY

[3]-2. Gear assembly and Motor section (cont.)

ASSEMBLING

(3) Put Leaf spring in place on the inside of Housing (L). (**Fig. 10**)

Fig. 10

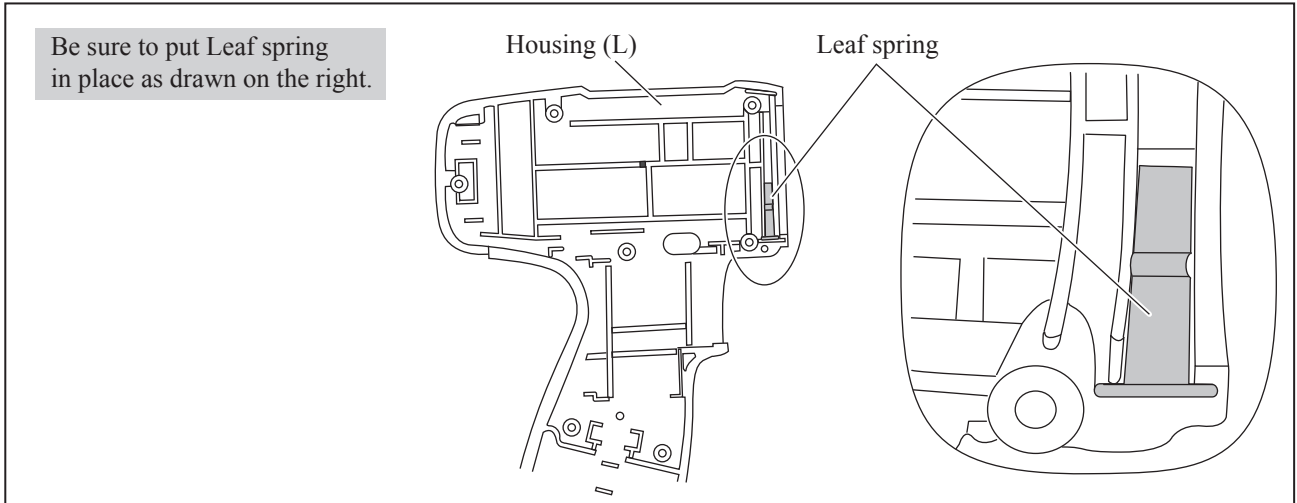

(4) Insert Armature into Yoke unit carefully and connect Motor section to Gear assembly. (**Fig. 11**)

Fig. 11

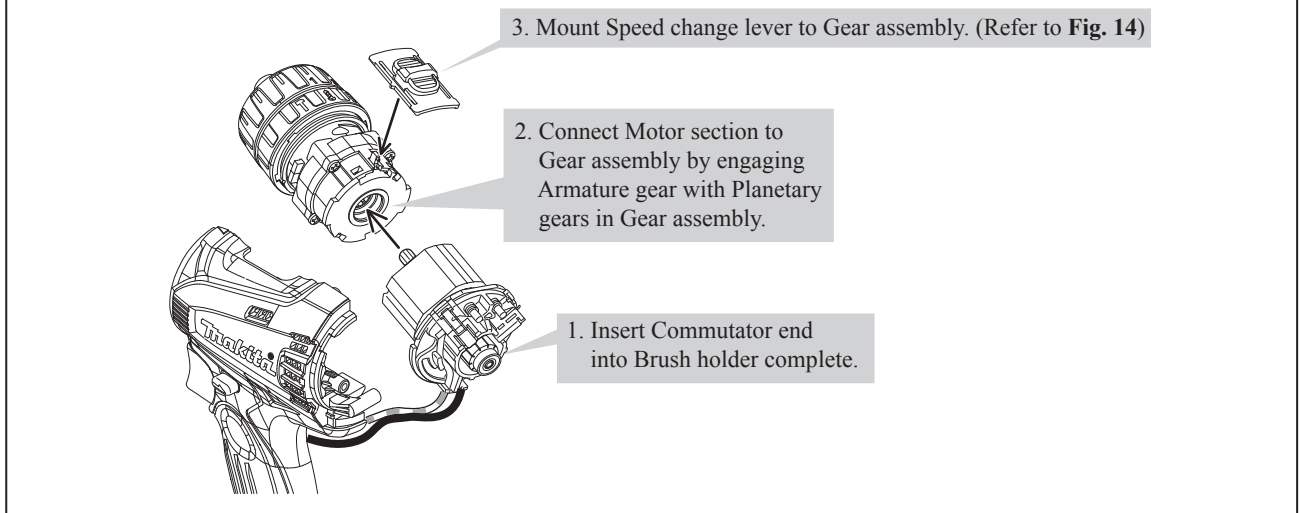
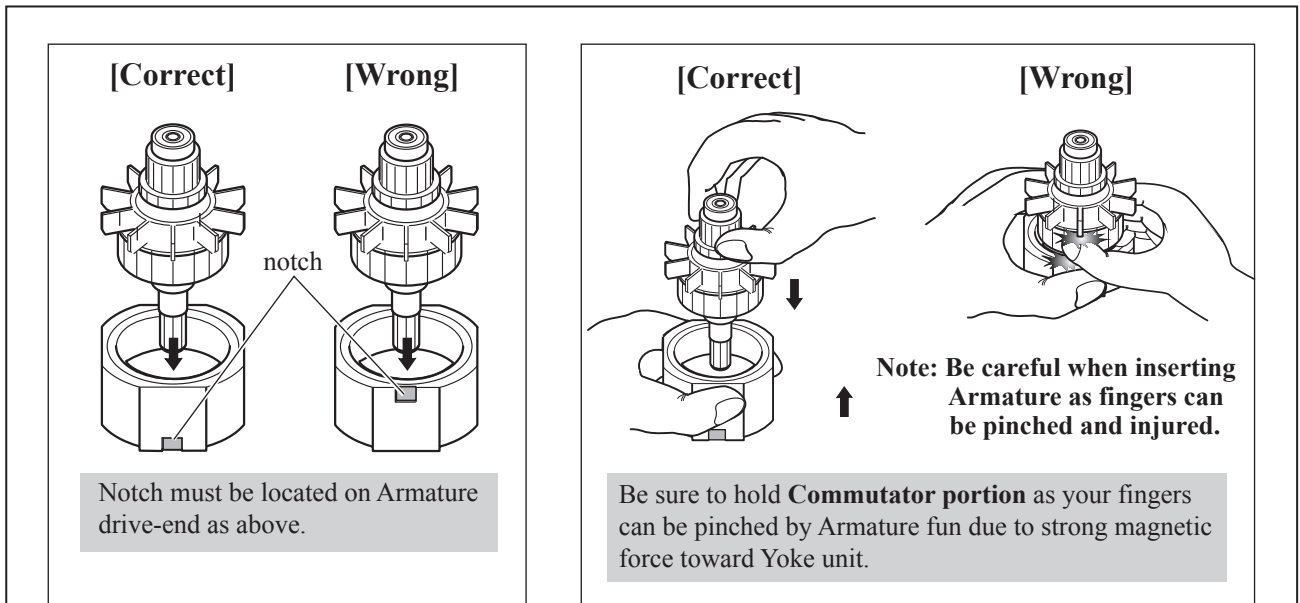

► Repair

[3] DISASSEMBLY/ASSEMBLY

[3]-2. Gear assembly and Motor section (cont.)

ASSEMBLING

- (5) Engage the notch of Yoke unit with the projection inside of Housing (L) when mounting the assembly of Gear section and Motor section to Housing (L). (**Fig. 12**)

Fig. 12

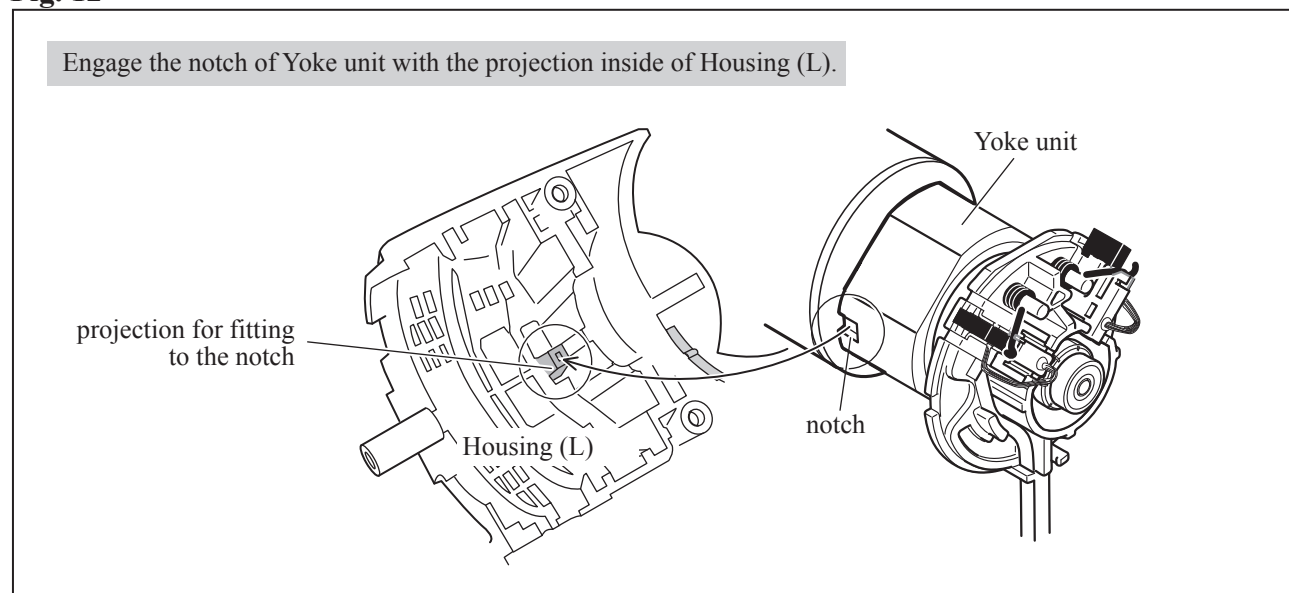

- (6) Adjust the assembly of Motor section and the Gear section to the correct position in Housing (L) so as to assemble Housing (R) to Housing (L) smoothly and exactly. (**Fig. 13**)

Fig. 13

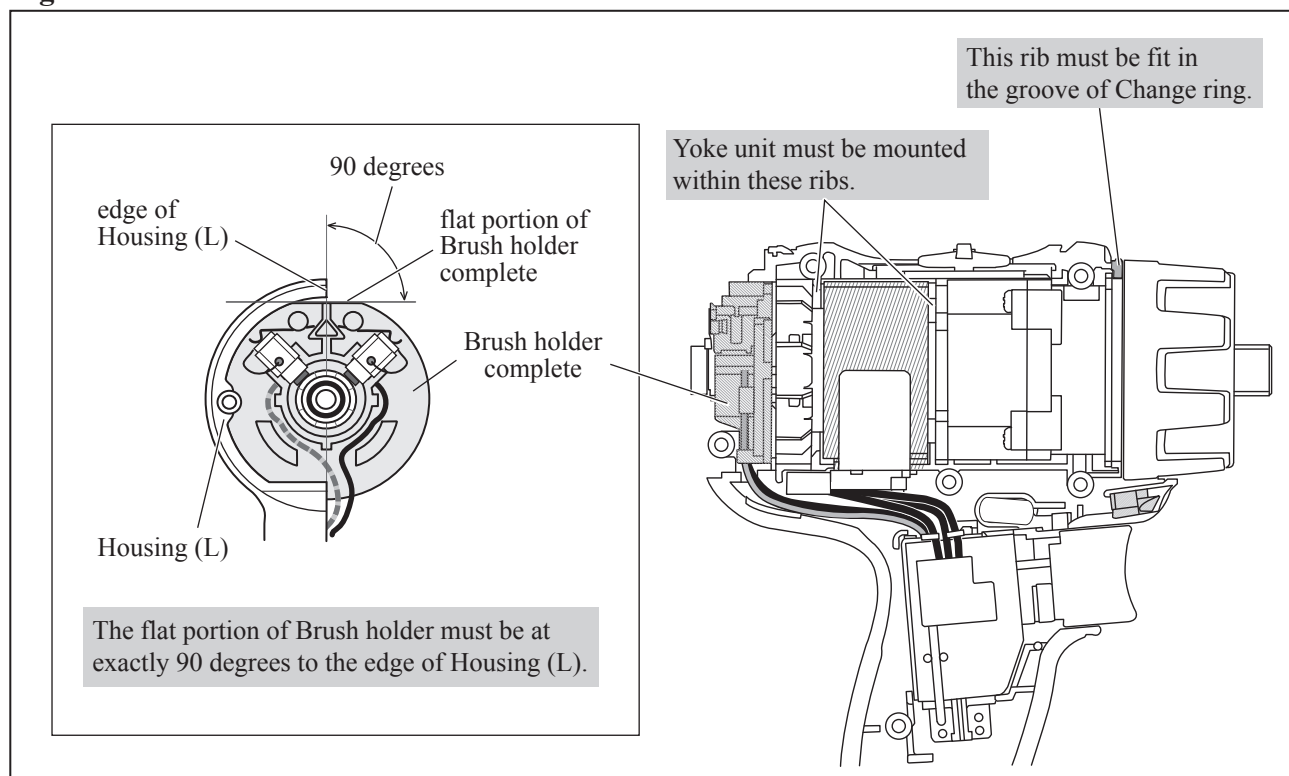

► **Repair**
[3] DISASSEMBLY/ASSEMBLY
[3]-3. Speed change lever

ASSEMBLING

Assemble Speed change lever to Gear assembly. (Fig. 14)

Fig. 14

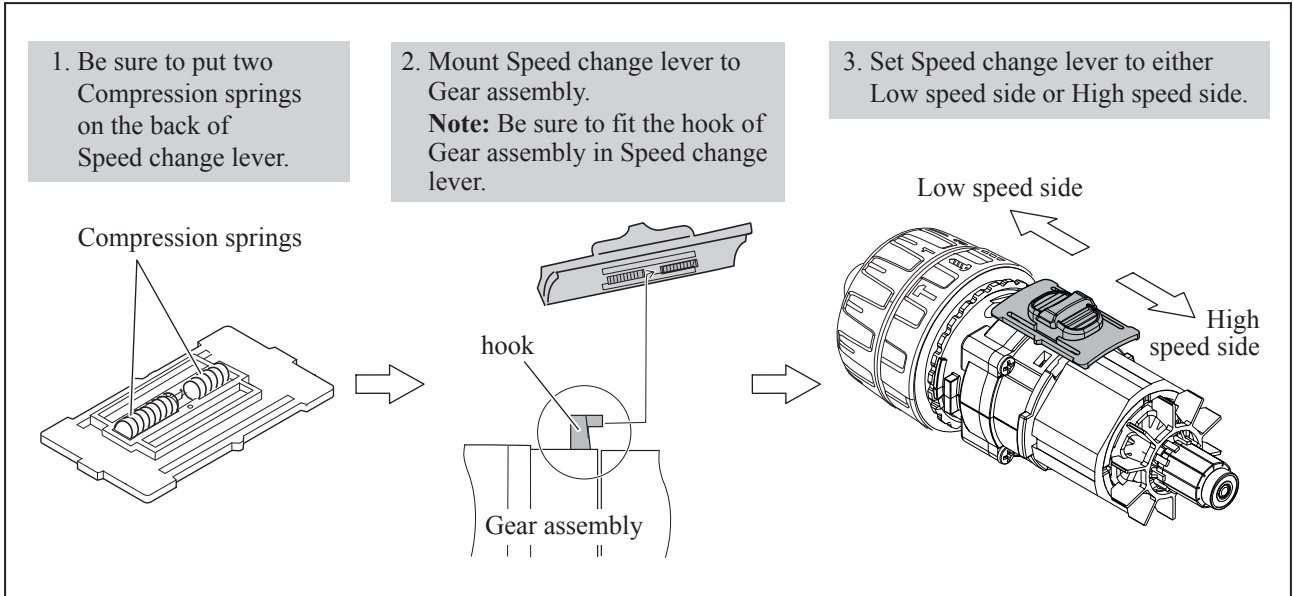

[3]-4. F/R Change lever

Mount F/R Change lever on Switch before assembling Housing (R) to Housing (L). (Fig. 15)

Fig. 15

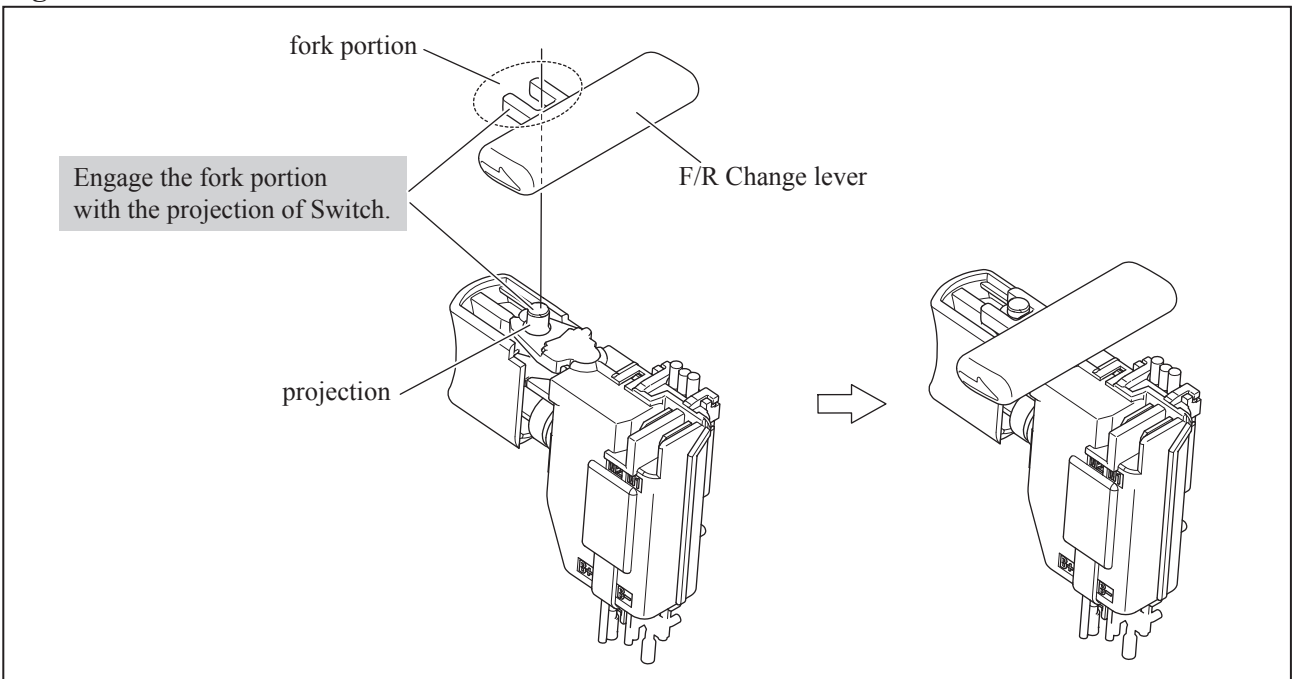

► **Circuit diagram**

Fig. D-1

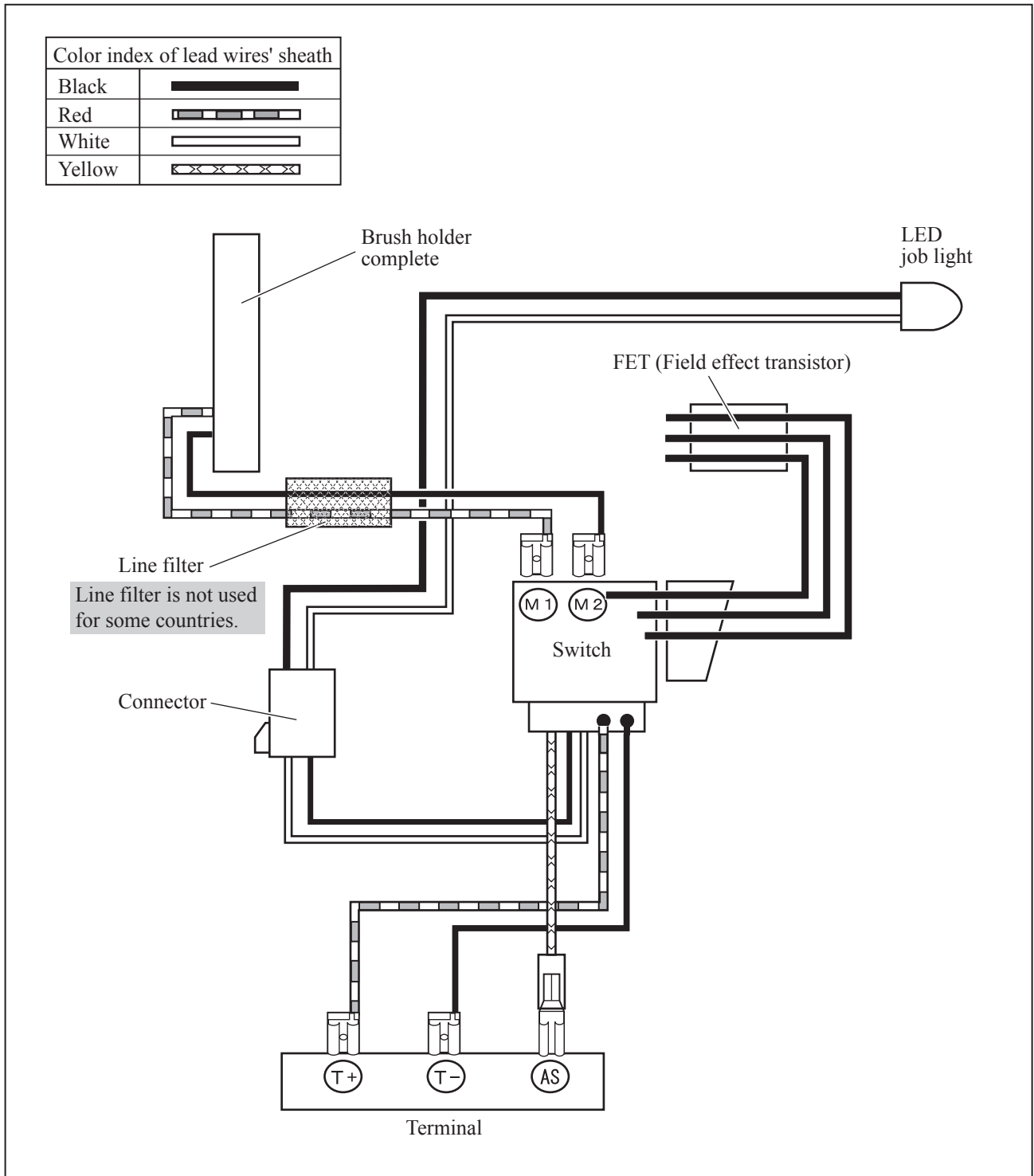

► **Wiring diagram**

Fig. D-2

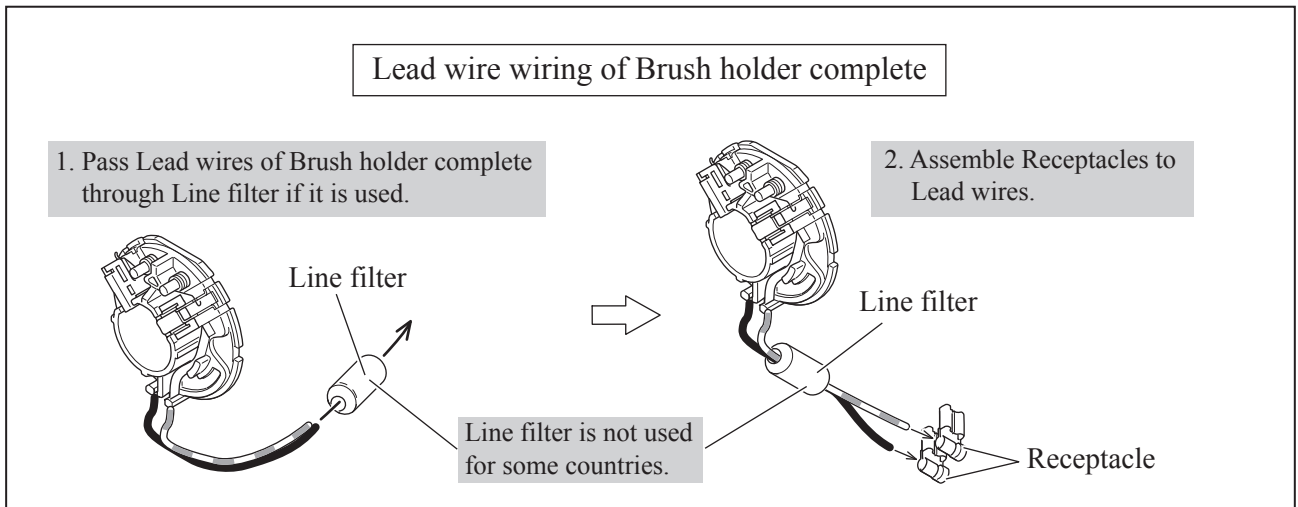
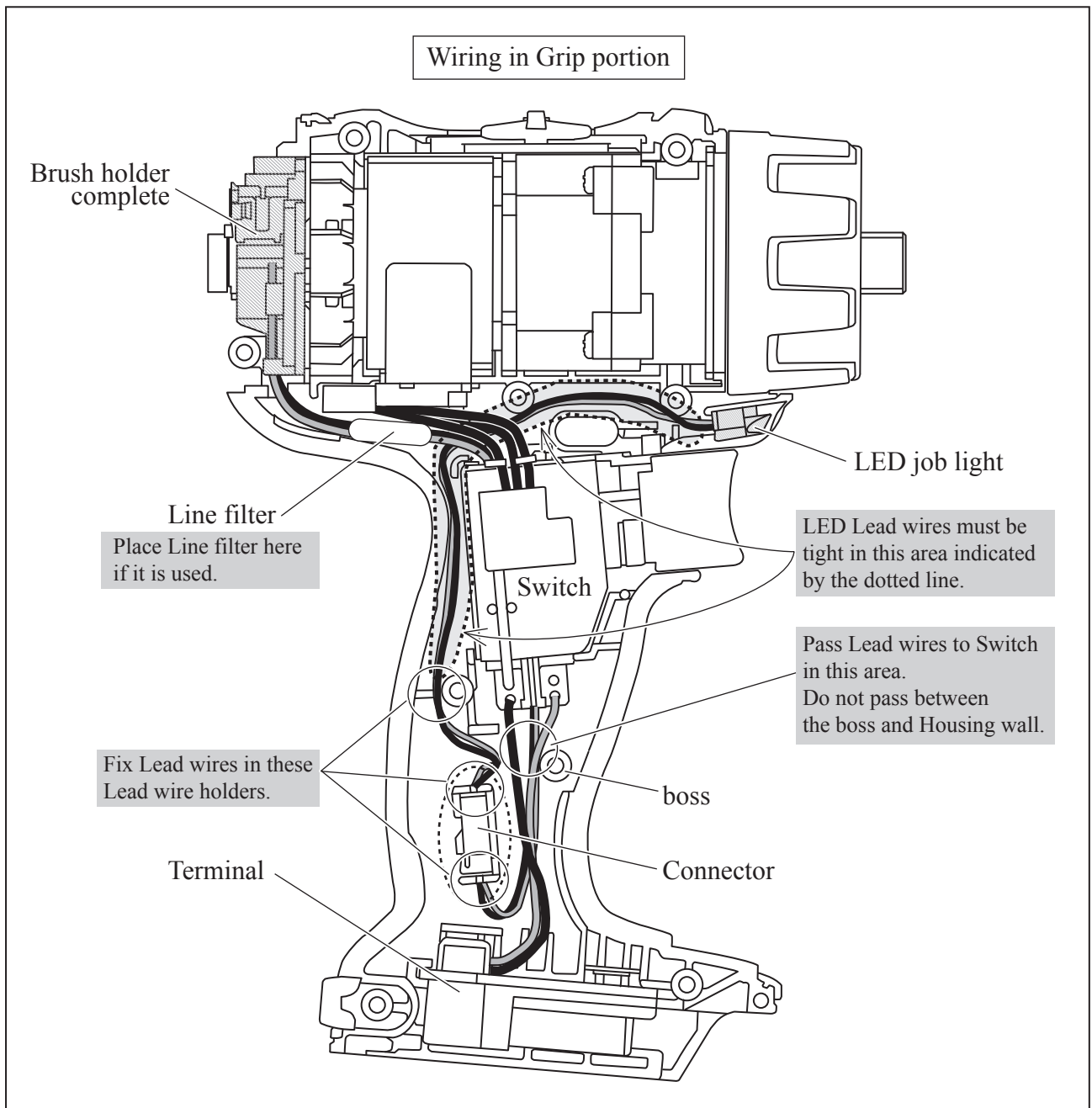

Fig. D-3



Free Manuals Download Website

<http://myh66.com>

<http://usermanuals.us>

<http://www.somanuals.com>

<http://www.4manuals.cc>

<http://www.manual-lib.com>

<http://www.404manual.com>

<http://www.luxmanual.com>

<http://aubethermostatmanual.com>

Golf course search by state

<http://golfingnear.com>

Email search by domain

<http://emailbydomain.com>

Auto manuals search

<http://auto.somanuals.com>

TV manuals search

<http://tv.somanuals.com>