

Makita

Slide Compound Saw

305 mm (12") MODEL LS1211

Equipped with Electric Brake

INSTRUCTION MANUAL

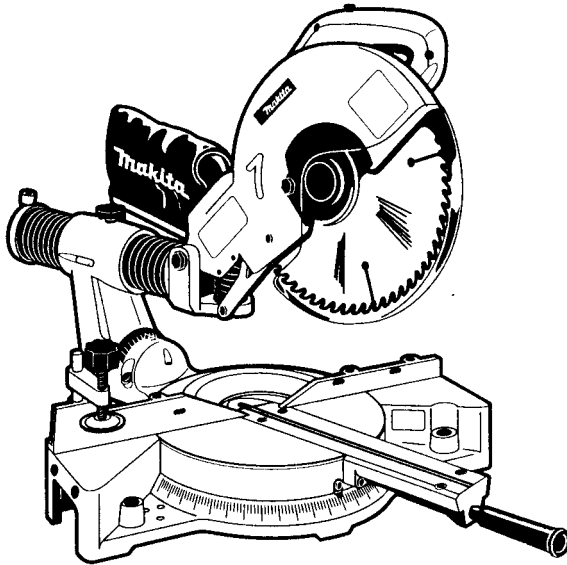

 **DOUBLE
INSULATION**

SPECIFICATIONS

Blade diameter 305 mm (12")

Arbor diameter 25.4 mm (1")

Max. cutting capacities (H x W)

Bevel angle	Left 45°	Right 45°	0°
Miter angle			
0°	<ul style="list-style-type: none"> 65 mm x 230 mm (2-9/16" x 9-1/16") 57 mm x 290 mm (2-1/4" x 11-7/16") 48 mm x 310 mm (1-7/8" x 12-3/16") 	<ul style="list-style-type: none"> 49 mm x 230 mm (1-15/16" x 9-1/16") 40 mm x 290 mm (1-9/16" x 11-7/16") 31 mm x 310 mm (1-1/4" x 12-3/16") 	<ul style="list-style-type: none"> 120 mm x 230 mm (4-3/4" x 9-1/16") 107 mm x 290 mm (4-3/16" x 11-7/16") 94 mm x 310 mm (3-11/16" x 12-3/16")
Left and right 45°	<ul style="list-style-type: none"> 65 mm x 162 mm (2-9/16" x 6-3/8") 57 mm x 205 mm (2-1/4" x 8-1/16") 48 mm x 219 mm (1-7/8" x 8-5/8") 	<ul style="list-style-type: none"> 49 mm x 162 mm (1-15/16" x 6-3/8") 40 mm x 205 mm (1-9/16" x 8-1/16") 31 mm x 219 mm (1-1/4" x 8-5/8") 	<ul style="list-style-type: none"> 120 mm x 162 mm (4-3/4" x 6-3/8") 107 mm x 205 mm (4-3/16" x 8-1/16") 94 mm x 219 mm (3-11/16" x 8-5/8")
Left and right 60°	—————	—————	<ul style="list-style-type: none"> 120 mm x 115 mm (4-3/4" x 4-1/2") 107 mm x 145 mm (4-3/16" x 5-11/16") 94 mm x 155 mm (3-11/16" x 6-1/8")

(Note)

- mark indicates that a wood facing with the following thickness is used.

Miter angle	Thickness of wood facing
0°	30 mm (1-3/16")
Left and right 45°	21 mm (13/16")
Left and right 60°	15 mm (9/16")

No load speed (RPM) 4,000

Dimensions (L x W x H) 1,040 mm x 605 mm x 620 mm
(40-15/16" x 23-13/16" x 24-7/16")

Net weight 23.2 kg (51.2 lbs)

- Manufacturer reserves the right to change specifications without notice.

- Note: Specifications may differ from country to country.

WARNING: For your personal safety, READ and UNDERSTAND before using.

SAVE THESE INSTRUCTIONS FOR FUTURE REFERENCE.

For Your Own Safety Read Instruction Manual Before Operating Slide Compound Saw

Save it for future reference

GENERAL SAFETY PRECAUTIONS

(For All Tools)

1. **KNOW YOUR POWER TOOL.** Read the owner's manual carefully. Learn the tools applications and limitations, as well as the specific potential hazards peculiar to it.
2. **KEEP GUARDS IN PLACE** and in working order.
3. **REMOVE ADJUSTING KEYS AND WRENCHES.** Form habit of checking to see that keys and adjusting wrenches are removed from tool before turning it on.
4. **KEEP WORK AREA CLEAN.** Cluttered areas and benches invite accidents.
5. **DON'T USE IN DANGEROUS ENVIRONMENT.** Don't use power tools in damp or wet locations, or expose them to rain. Keep work area well lighted. Don't use tool in presence of flammable liquids or gases.
6. **KEEP CHILDREN AWAY.** All visitors should be kept safe distance from work area.
7. **MAKE WORKSHOP CHILD PROOF** with padlocks, master switches, or by removing starter keys.
8. **DON'T FORCE TOOL.** It will do the job better and safer at the rate for which it was designed.
9. **USE RIGHT TOOL.** Don't force tool or attachment to do a job for which it was not designed.
10. **WEAR PROPER APPAREL.** Wear no loose clothing, gloves, neckties, rings, bracelets, or other jewelry which may get caught in moving parts. Nonslip footwear is recommended. Wear protective hair covering to contain long hair.
11. **ALWAYS USE SAFETY GLASSES.** Also use face or dust mask if cutting operation is dusty. Everyday eyeglasses only have impact resistant lenses, they are NOT safety glasses.
12. **SECURE WORK.** Use clamps or a vise to hold work when practical. It's safer than using your hand and it frees both hands to operate tool.
13. **DON'T OVERREACH.** Keep proper footing and balance at all times.
14. **MAINTAIN TOOLS WITH CARE.** Keep tools sharp and clean for best and safest performance. Follow instructions for lubricating and changing accessories.
15. **DISCONNECT TOOLS** before servicing, when changing accessories such as blades, bits, cutters, and the like.

- 16. EXTENSION CORDS.** Make sure your extension cord is in good condition. When using an extension cord, be sure to use one heavy enough to carry the current your product will draw. An undersized cord will cause a drop in line voltage resulting in loss of power and overheating. Table 1 shows the correct size to use depending on cord length and nameplate ampere rating. If in doubt, use the next heavier gauge. The smaller the gauge number, the heavier the cord.

TABLE 1 MINIMUM GAUGE FOR CORD SETS

		Total Length of Cord in Feet			
		0 – 25	26 – 50	51 – 100	101 – 150
Ampere Rating More Than	Not More Than	A W G			
0	– 6	18	16	16	14
6	– 10	18	16	14	12
10	– 12	16	16	14	12
12	– 16	14	12	Not Recommended	

- 17. REDUCE THE RISK OF UNINTENTIONAL STARTING.** Make sure switch is in off position before plugging in.
- 18. USE RECOMMENDED ACCESSORIES.** Consult the owner's manual for recommended accessories. The use of improper accessories may cause risk of injury to persons.
- 19. NEVER STAND ON TOOL.** Serious injury could occur if the tool is tipped or if the cutting tool is accidentally contacted.
- 20. CHECK DAMAGED PARTS.** Before further use of the tool, a guard or other part that is damaged should be carefully checked to determine that it will operate properly and perform its intended function — check for alignment of moving parts, binding of moving parts, breakage of parts, mounting, and any other conditions that may affect its operation. A guard or other part that is damaged should be properly repaired or replaced.
- 21. DIRECTION OF FEED.** Feed work into a blade or cutter against the direction of rotation of the blade or cutter only.
- 22. NEVER LEAVE TOOL RUNNING UNATTENDED. TURN POWER OFF.** Don't leave tool until it comes to a complete stop.
- 23.** When servicing use only identical replacement parts.

VOLTAGE WARNING: Before connecting the tool to a power source (receptacle, outlet, etc.) be sure the voltage supplied is the same as that specified on the nameplate of the tool. A power source with voltage greater than that specified for the tool can result in **SERIOUS INJURY** to the user — as well as damage to the tool. If in doubt, **DO NOT PLUG IN THE TOOL.** Using a power source with voltage less than the nameplate rating is harmful to the motor.

ADDITIONAL SAFETY RULES

1. Wear eye protection.
2. Do not operate saw without guards in place.
3. Don't use the tool in the presence of flammable liquids or gases.
4. Check the blade carefully for cracks or damage before operation. Replace cracked or damaged blade immediately.
5. Use only flanges specified for this tool.
6. Be careful not to damage the arbor, flanges (especially the installing surface) or bolt. Damage to these parts could result in blade breakage.
7. Make sure that the turn base is properly secured so it will not move during operation.
8. For your safety, remove the chips, small pieces, etc. from the table top before operation.
9. Avoid cutting nails. Inspect for and remove all nails from the workpiece before operation.
10. Make sure the shaft lock is released before the switch is turned on.
11. Be sure that the blade does not contact the turn base in the lowest position.
12. Hold the handle firmly. Be aware that the saw moves up or down slightly during start-up and stopping.
13. Do not perform any operation freehand. The workpiece must be secured firmly against the turn base and guide fence with the vise during all operations. Never use your hand to secure the workpiece.
14. Keep hands out of path of saw blade. Avoid contact with any coasting blade. It can still cause severe injury.
15. Never reach around saw blade.
16. Make sure the blade is not contacting the workpiece before the switch is turned on.
17. Before using the tool on an actual workpiece, let it run for a while. Watch for vibration or wobbling that could indicate poor installation or a poorly balanced blade.
18. Wait until the blade attains full speed before cutting.
19. Stop operation immediately if you notice anything abnormal.
20. Do not attempt to lock the trigger in the on position.
21. Shut off power and wait for saw blade to stop before servicing or adjusting tool.
22. Be alert at all times, especially during repetitive, monotonous operations. Don't be lulled into a false sense of security. Blades are extremely unforgiving.
23. Always use accessories recommended in this manual. Use of improper accessories such as abrasive wheels may cause an injury.
24. Don't abuse cord. Never yank cord to disconnect it from the receptacle. Keep cord away from heat, oil, water and sharp edges.

SAVE THESE INSTRUCTIONS.

Socket wrench

Store the socket wrench in the wrench holder at the rear of the tool after using it.

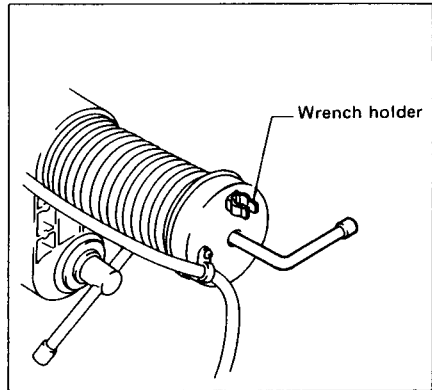

Bench mounting saw

When the tool is shipped, the handle is locked in the lowered position. Release the handle from the lowered position by lowering it slightly and removing the chain from the screw on the motor housing.

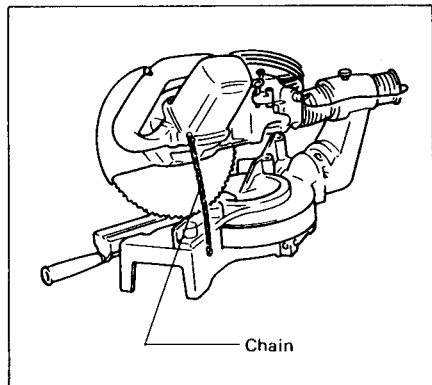

This tool should be bolted with two bolts to a level and stable surface using the bolt holes provided in the tool's base. This will help prevent tipping and possible injury.

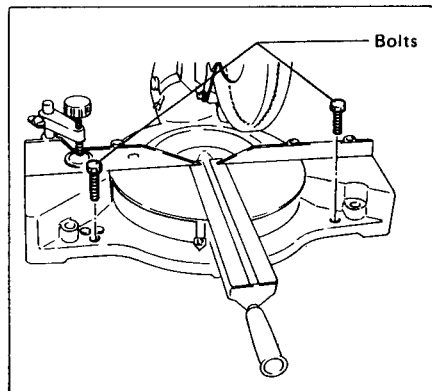

Installing or removing saw blade

CAUTION:

Always be sure that the tool is switched off and unplugged before installing or removing the blade.

Use the socket wrench to loosen the hex bolt which secures the center cover by turning counterclockwise. Raise the safety cover and the center cover.

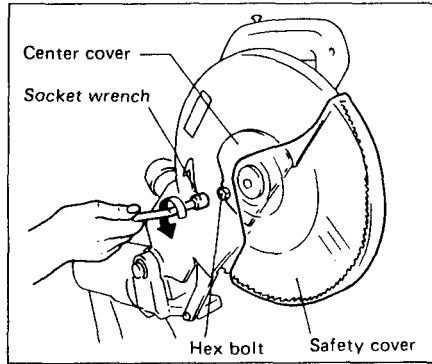

Press the shaft lock to lock the spindle and use the socket wrench to loosen the hex bolt by turning it clockwise. Then remove the hex bolt, outer flange and blade.

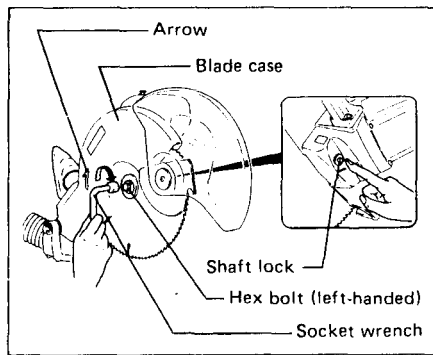

To install the blade, mount it carefully onto the spindle, making sure that the direction of the arrow on the surface of the blade matches the direction of the arrow on the blade case.

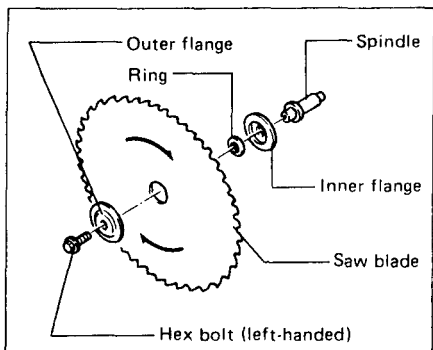

Install the outer flange and hex bolt, and then use the socket wrench to tighten the hex bolt securely by turning it counter-clockwise while pressing the shaft lock. Return the safety cover and the center cover to the original position. Then tighten the hex bolt to secure the center cover. Lower the handle to make sure that the safety cover moves properly.

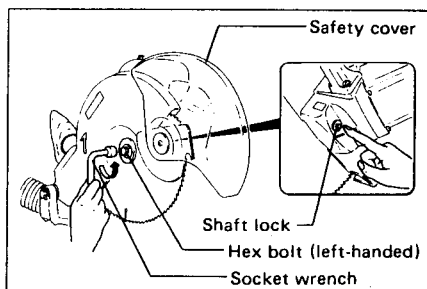

CAUTION:

Use only the Makita socket wrench provided to install or remove the blade. Failure to do so may result in overtightening or insufficient tightening of the hex bolt. This could cause serious injury to operator or others in the general vicinity of the tool.

Safety cover

When lowering the handle, the safety cover rises automatically. The cover returns to its original position when the cut is completed and the handle is raised. NEVER DEFEAT OR REMOVE THE SAFETY COVER. In the interest of your personal safety, always maintain the safety cover in good condition. Any irregular operation of the safety cover should be corrected immediately. NEVER USE THE TOOL WITH A FAULTY SAFETY COVER. If the see-through safety cover becomes dirty, or sawdust adheres to it in such a way that the blade and/or work-piece is no longer easily visible, unplug the saw and clean the cover carefully with a damp cloth. Do not use solvents or any petroleum-based cleaners on the plastic cover.

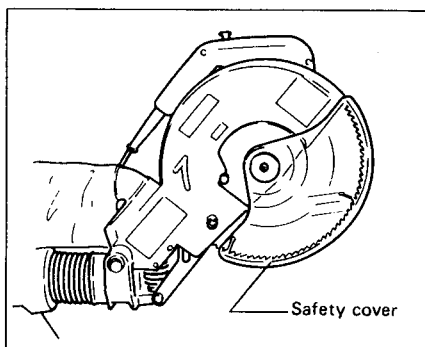

Dust bag

To attach the dust bag, fit it into the elbow. When the dust bag is about half full, remove the dust bag from the tool and pull the fastener out. Empty the dust bag by tapping it lightly to remove as much dust as possible.

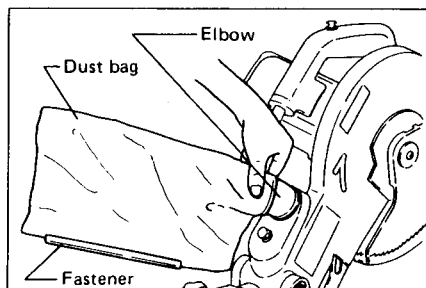

NOTE:

If you connect a vacuum cleaner to your saw, more efficient and cleaner operations can be performed.

Positioning kerf boards

This tool is provided with kerf boards in the turn base. The kerf boards are factory-adjusted so that the saw blade does not contact the kerf boards. Before use, adjust the kerf boards as follows:

First unplug the tool. Loosen the all screws (2 each on left and right) which secure the kerf boards. Retighten them to the extent that the kerf boards can be easily moved by hand. Loosen the clamp screw on the arm. Pull the carriage toward you fully and lower the handle fully. Adjust the kerf boards so that the kerf boards just contact the sides of blade teeth slightly. Tighten the front screws (do not tighten firmly). Push the carriage toward the guide fence fully and adjust the kerf boards so that the kerf boards just contact the sides of blade teeth slightly. Tighten the rear screws (do not tighten firmly). After adjusting the kerf boards, tighten the all screws securely.

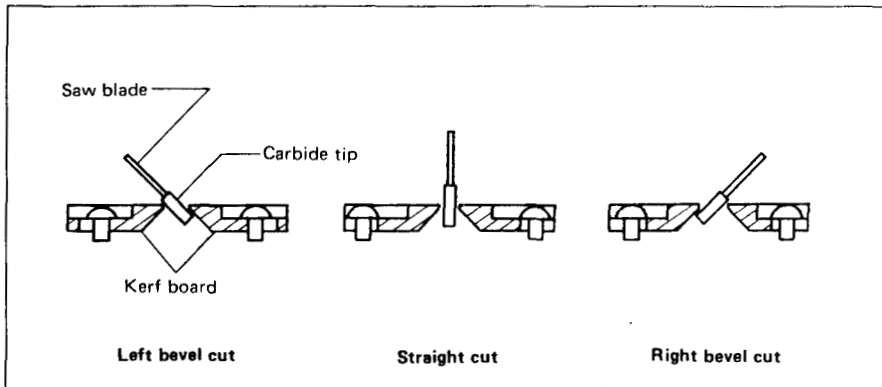
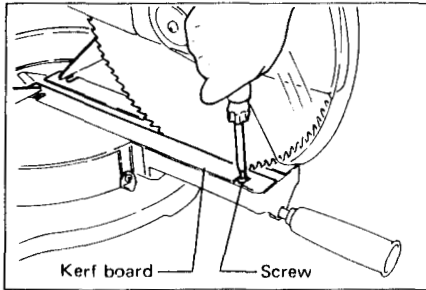

CAUTION:

After changing the bevel angle, always readjust the kerf boards as described above.

Maintaining maximum cutting capacity

This tool is factory adjusted to provide the max. cutting capacity for a 305 mm (12") saw blade. When using a saw blade other than the 305 mm (12") saw blade, adjust the lower limit position of the blade as follows:

First unplug the tool. Push the carriage toward the guide fence fully and lower the handle completely. Use the socket wrench to turn the adjusting bolt until the periphery of the blade extends slightly below the top surface of the turn base at the point where the front face of the guide fence meets the top surface of the turn base. With the tool unplugged, rotate the blade by hand while holding the handle all the way down to be sure that the blade does not contact any part of the lower base. Re-adjust slightly, if necessary.

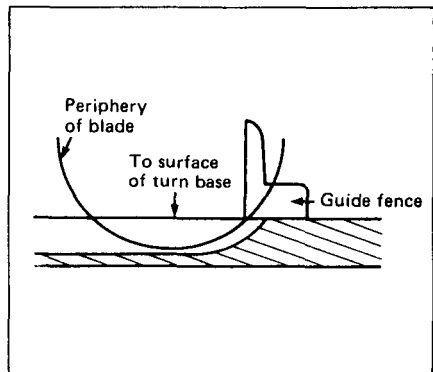
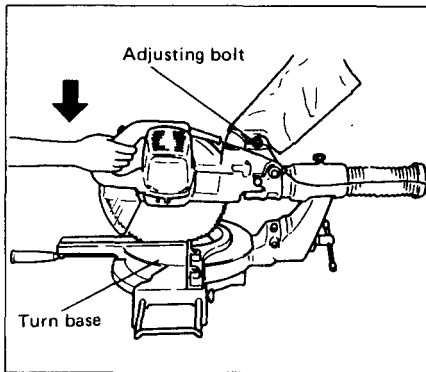

CAUTION:

After installing a new blade, always be sure that the blade does not contact any part of the lower base when the handle is lowered completely.

Positioning for adjusting the miter angle

The turn base turns up to 60° to the left and right. Loosen the grip and turn the turn base to the position where the pointer points to the desired angle on the miter scale. Then, tighten the grip firmly to secure turn base.

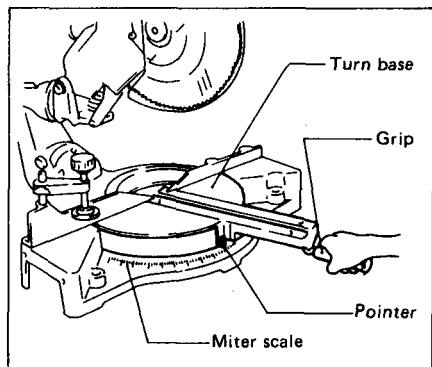

CAUTION:

- When turning the turn base, be sure to raise the handle fully.
- After changing the miter angle, always secure the turn base by tightening the grip firmly.

Positioning for adjusting the bevel angle

The saw blade tilts up to 45° to the left and right. To adjust the bevel angle, loosen the lever at the rear of the tool.

For left bevel cutting, tilt the saw blade to the left until the pointer points to the desired angle. Then tighten the lever firmly to secure the arm.

For right bevel cutting, press the release button after tilting the saw blade slightly to the left. While pressing the release button, tilt the saw blade to the right until the pointer points to the desired angle. Then tighten the lever firmly to secure the arm.

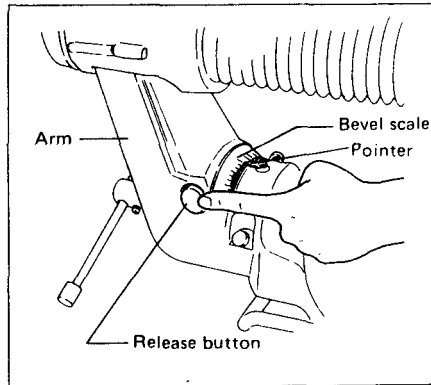
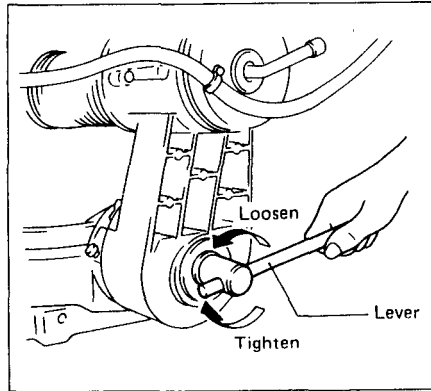

CAUTION:

- When tilting the saw blade, be sure to raise the handle fully.
- After changing the bevel angle, always secure the arm by tightening the lever.
- When changing bevel angles, be sure to position the kerf boards appropriately as explained in the "Positioning kerf boards" section.

Securing workpiece

WARNING:

It is extremely important to always secure the workpiece properly and tightly with the vise. Failure to do so can cause the tool to be damaged and/or the workpiece to be destroyed. **PERSONAL INJURY MAY ALSO RESULT.** Also, after any cutting operation, **DO NOT** raise the blade until the blade has come to a complete stop.

1. Vertical vise

The vertical vise can be installed in two positions on either the left or right side of the guide fence, or holder assembly (optional accessory). Insert the vise rod into the hole in the guide fence or holder assembly and tighten the screw to secure the vise rod. (Note: When using the holder assembly, install it on the holder (optional accessory) as shown in the figure.) Position the vise arm according to the thickness and shape of the workpiece and secure the vise arm by tightening the screw. Make sure that no part of the tool contacts the vise when lowering the handle fully or when pulling or pushing the carriage. If some part contacts the vise, re-position the vise. Press the workpiece flat against the guide fence and the turn base. Position the workpiece at the desired cutting position and secure it firmly by tightening the clamp screw of the vise. The maximum thickness of workpieces which can be secured by the vertical vise is 120 mm (4-3/4").

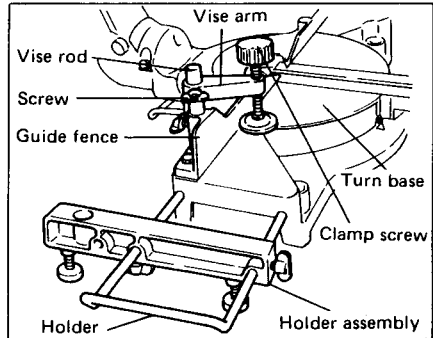

CAUTION:

The workpiece must always be secured firmly against the turn base and guide fence with the vise during all operations.

2. Horizontal vise (optional accessory)

The horizontal vise can be installed in two positions on either the left or right side of the base. When performing 15° or greater miter cuts, install the horizontal vise on the side opposite the direction in which the turn table is to be turned. By flipping the vise nut to the left, the vise is released, and rapidly moves in and out. To grip workpieces, push the vise knob forward until the vise plate contacts the workpiece and flip the vise nut to the right. Then turn the vise knob clockwise to secure the workpiece. The maximum width of workpieces which can be secured by the horizontal vise is 200 mm (7-7/8").

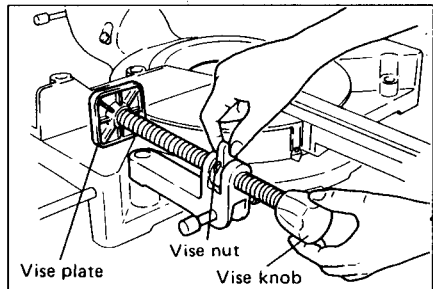

CAUTION:

Always set the vise nut to the right fully when securing the workpiece. Failure to do so may result in insufficient securing of the workpiece. This could cause the workpiece to be thrown, cause damage to the blade or cause the dangerous loss of control of the tool.

3. Holders and holder assembly (optional accessories)

The holders and the holder assembly can be installed on either side as a convenient means of supporting workpieces horizontally. Install them as shown in the figures. Then tighten the screws firmly to secure the holders and the holder assembly.

CAUTION:

Always support long workpieces level with the top surface of the turn base for accurate cuts and to prevent dangerous loss of control of the tool.

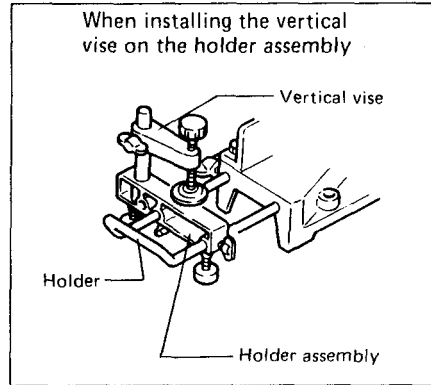
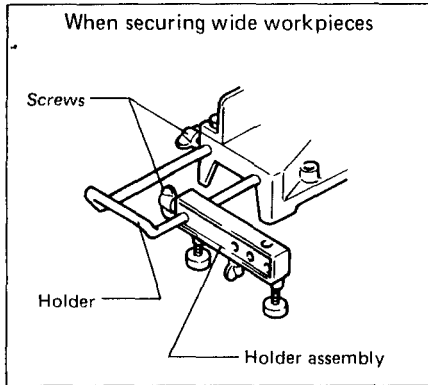

Switch action

To prevent the trigger from being accidentally actuated, a lock-off button is provided. To start the tool, press in the lock-off button and pull the trigger at the same time. Release the trigger to stop.

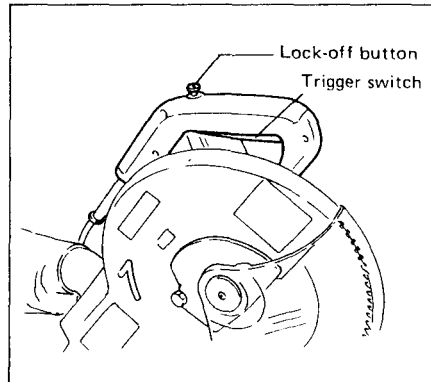

CAUTION:

- Before plugging in the tool, always check to see that the trigger switch actuates properly and returns to the "OFF" position when released.
- When not using the tool, remove the lock-off button and store it in a secure place. This prevents unauthorized operation.
- Do not pull the trigger hard without pressing in the lock-off button. This can cause breakage of the switch.

Operation

CAUTION:

- Make sure the blade is not contacting the workpiece, etc. before the switch is turned on.
- Do not apply excessive pressure on the handle when cutting. Too much force may result in overload of the motor and/or decreased cutting efficiency.
- Gently press down the handle to perform the cut. If the handle is pressed down with force or if lateral force is applied, the blade will vibrate and leave a mark (saw mark) in the workpiece and the precision of the cut will be impaired.
- During a slide cut, gently push the carriage toward the guide fence without stopping. If the carriage movement is stopped during the cut, a mark will be left in the workpiece and the precision of the cut will be impaired.

1. Press cutting (cutting small workpieces)

- Workpieces up to 94 mm (3-11/16") high and 130 mm (5-1/8") wide or 107 mm (4-3/16") high and 110 mm (4-5/16") wide can be cut in the following way.
- Push the carriage toward the guide fence fully and tighten the clamp screw on the arm to secure the carriage in the "back" position. Secure the workpiece with a vise. Switch on the tool and wait until the blade attains full speed before lowering gently into the cut. When the cut is completed, switch off the tool and **WAIT UNTIL THE BLADE HAS COME TO A COMPLETE STOP** before returning the blade to its fully elevated position.

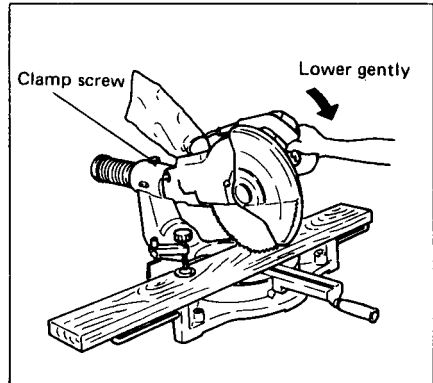

CAUTION:

Firmly tighten the clamp screw on the arm so that the carriage will not move during operation. Insufficient tightening may cause unexpected kickback of the blade. Possible serious injury may result.

2. Slide (push) cutting (cutting wide workpieces)

- Workpieces up to 94 mm (3-11/16") high and 310 mm (12-3/16") wide or 107 mm (4-3/16") high and 290 mm (11-7/16") wide can be cut in the following way.
- Loosen the clamp screw on the arm so that the carriage can slide freely. Secure the workpiece with a vise. Pull the carriage toward you fully. Switch on the tool and wait until the blade attains full speed. Then gently lower the handle to the fully lowered position and PUSH THE CARRIAGE TOWARD THE GUIDE FENCE TO CUT THE WORKPIECE. When the cut is completed, switch off the tool and WAIT UNTIL THE BLADE HAS COME TO A COMPLETE STOP before returning the blade to its fully elevated position.

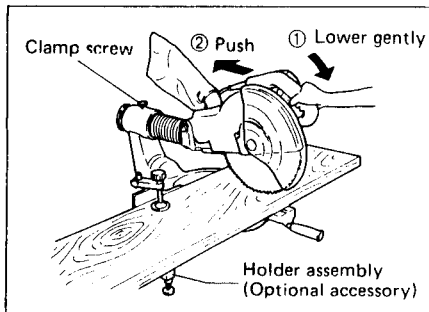

CAUTION:

Whenever performing the slide cut, FIRST PULL THE CARRIAGE TOWARD YOU FULLY and press down the handle to the fully lowered position, then PUSH THE CARRIAGE TOWARD THE GUIDE FENCE. If you perform the slide cut without pulling the carriage fully or if you perform the slide cut toward your direction, the blade may kick back unexpectedly with the potential to cause serious injury.

3. Miter cutting

Refer to the previously covered "Positioning for adjusting the miter angle".

4. Bevel cut

- Left and right 0° – 45° bevel cuts can be performed. At a left 45° bevel angle, workpieces up to 48 mm (1-7/8") high and 310 mm (12-3/16") wide or 57 mm (2-1/4") high and 290 mm (11-7/16") wide can be cut. At a right 45° bevel angle, workpieces up to 31 mm (1-1/4") high and 310 mm (12-3/16") wide or 40 mm (1-9/16") high and 290 mm (11-7/16") wide can be cut.
- Loosen the lever and tilt the saw blade to set the bevel angle. Be sure to re-tighten the lever firmly to secure the selected bevel angle safely. Secure the workpiece with a vise. Switch on the tool and wait until the blade attains full speed. Then gently lower the handle to the fully lowered position while applying pressure in parallel with the blade and PUSH THE CARRIAGE TOWARD THE GUIDE FENCE TO CUT THE WORKPIECE. When the cut is completed, switch off the tool and WAIT UNTIL THE BLADE HAS COME TO A COMPLETE STOP before returning the blade to its fully elevated position.

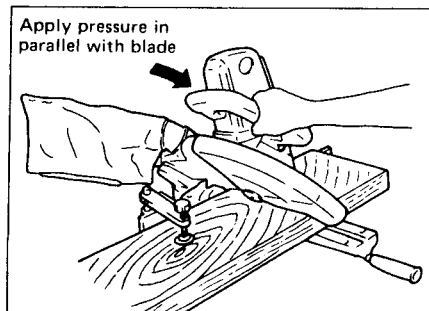

CAUTION:

- During a bevel cut, it may create a condition whereby the piece cut off will come to rest against the side of the blade. If the blade is raised while the blade is still rotating, this piece may be caught by the blade, causing fragments to be scattered around which is dangerous. The blade should be raised **ONLY** after the blade has come to a complete stop.
- When pressing down the handle, apply pressure in parallel with the blade. If a force is applied perpendicularly to the turn base or if the pressure direction is changed during a cut, the precision of the cut will be impaired.

5. Compound cutting

Compound cutting is the process in which a bevel angle is made at the same time in which a miter angle is being cut on a workpiece. Compound cutting can be performed at angle shown in the table below.

Bevel angle	Miter angle
Left and right 45°	Left and right 0° – 45°
Left and right 40°	Left and right 0° – 50°
Left and right 35°	Left and right 0° – 55°
Left and right 0° – 30°	Left and right 0° – 60°

At the miter angle of left and right 45° and bevel angle of left 45°, workpieces up to 48 mm (1-7/8") high and 219 mm (8-5/8") wide or 57 mm (2-1/4") high and 205 mm (8-1/16") wide can be cut.

At the miter angle of left and right 45° and bevel angle of right 45°, workpieces up to 31 mm (1-7/32") high and 219 mm (8-5/8") wide or 40 mm (1-9/16") high and 205 mm (8-1/16") wide can be cut.

When performing compound cutting, refer to "Press cutting", "Slide cutting", "Miter cutting" and "Bevel cut" explanations.

6. Cutting crown and cove moldings

- Crown and cove moldings can be cut on a compound miter saw with the moldings laid flat on the turn base.
- There are two common types of crown moldings and one type of cove molding: 52/38° wall angle crown molding, 45° wall angle crown molding and 45° wall angle cove molding. See illustrations below.

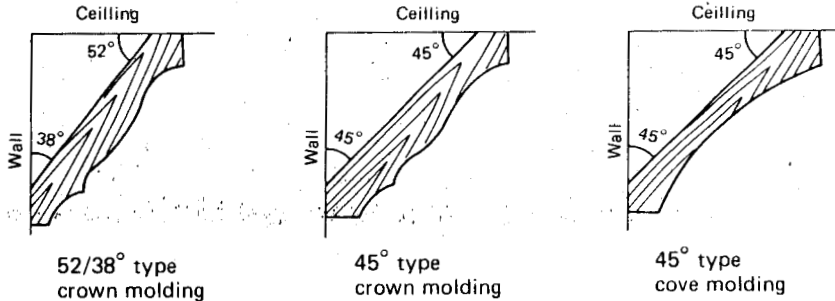

- There are crown and cove molding joints which are made to fit "Inside" 90° corners (① and ② in Fig. A) and "Outside" 90° corners (③ and ④ in Fig. A).

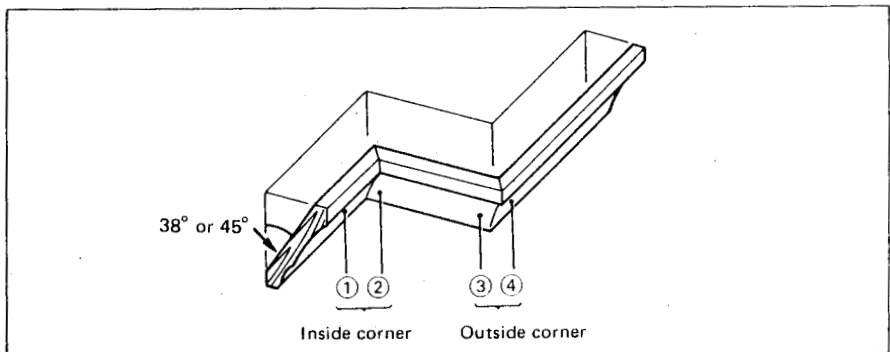
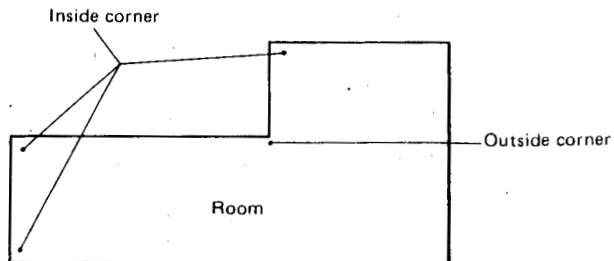

Fig. (A)



When cutting crown and cove moldings, set the bevel angle and miter angle as indicated in the table (A) and position the moldings on the top surface of the saw base as indicated in the table (B).

Table (A)

	Molding position in Fig. (A)	Bevel angle		Miter angle	
		52/38° type	45° type	52/38° type	45° type
For inside corner	①	33.9°	30°	Right 31.6°	Right 35.3°
	②			Left 31.6°	Left 35.3°
For outside corner	③			Right 31.6°	Right 35.3°
	④				

Table (B)

	Molding position in Fig. (A)	Molding edge against guide fence	Finished piece
For inside corner	①	Ceiling contact edge should be against guide fence.	Finished piece will be on the Left side of blade.
	②	Wall contact edge should be against guide fence.	
For outside corner	③	Ceiling contact edge should be against guide fence.	Finished piece will be on the Right side of blade.
	④		

(Example)

In the case of cutting 5/38° type crown molding for position ① in Fig. (A):

- Tilt and secure bevel angle setting to 33.9°.
- Adjust and secure miter angle setting to 31.6° RIGHT.
- Lay crown molding with its broad back surface down on the turn base with its CEILING CONTACT EDGE against the guide fence on the saw.
- The finished piece to be used will always be on the LEFT side of the blade after the cut has been made.

7. Cutting aluminum extrusion

When securing aluminum extrusions, use spacer blocks or pieces of scrap as shown in the figure to prevent deformation of the aluminum. Use a cutting lubricant on the blade teeth when cutting the aluminum extrusion to prevent build-up of the aluminum material on the blade.

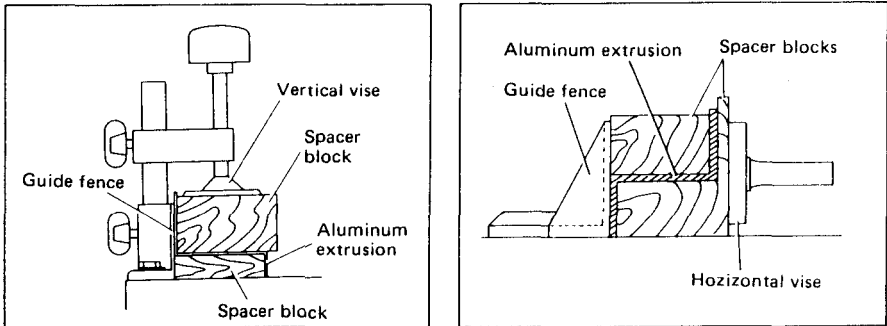

CAUTION:

Never attempt to cut thick or round aluminum extrusions. Thick aluminum extrusions may come loose during the cutting operation and round aluminum extrusions are very difficult to be secured firmly and safely with this tool.

8. Wood facing

When cutting workpieces from 107 mm (4-3/16") to 120 mm (4-3/4") high, use a wood facing attached to the face of the guide fence to prevent a portion of the workpiece near the guide fence from being left uncut. Attach a straight wood board of even thickness to the guide fence using the holes in the guide fence and screws. The screws should be installed so that their heads remain beneath the surface of the wood facing. See the figure below concerning the dimensions for a suggested wood facing.

NOTE:

When using a wood facing, the max. cutting width will be reduced by the thickness of the wood facing.

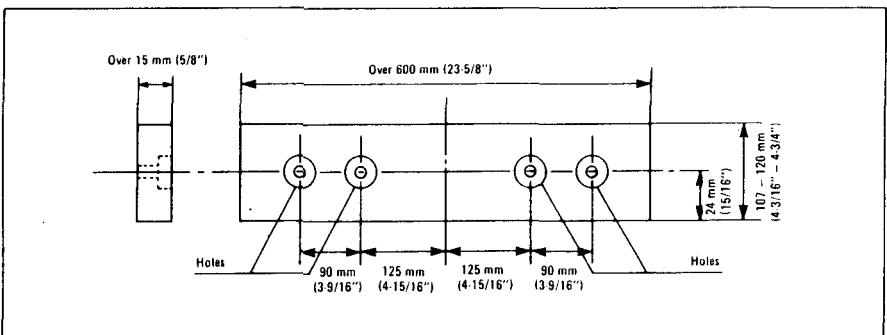

(Example)

When cutting workpieces 120 mm (4-3/4") high, use a wood facing with the following thickness.

Miter angle	Thickness of wood facing
0°	Over 30 mm (1-3/16")
Left and right 45°	Over 21 mm (13/16")
Left and right 60°	Over 15 mm (9/16")

9. Cutting repetitive lengths

When cutting several pieces of stock to the same length, ranging from 305 mm (12") to 440 mm (17-5/16"), use of the set plate (optional accessory) will facilitate more efficient operation. Install the set plate on the holder (optional accessory) as shown in the figure. Align the cutting line on your workpiece with either the left or right side of the groove in the kerf board, and while holding the workpiece from moving, move the set plate flush against the end of the workpiece. Then secure the set plate with the screw. When the set plate is not used, loosen the screw and turn the set plate out of the way.

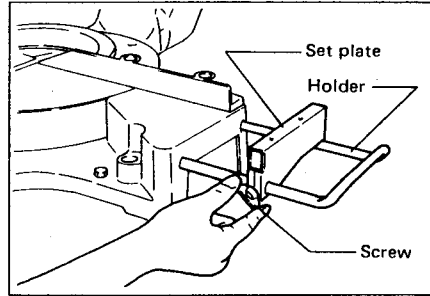

10. Groove cutting

A dado type cut can be made by proceeding as follows: Adjust the lower limit position of the blade using the adjusting screw on the stopper arm to limit the cutting depth of the blade. To adjust it, rotate the stopper arm to the position shown in the figure. Adjust the adjusting screw so that the blade stops at the desired position when lowering the handle fully. After adjusting the lower limit position of the blade, cut parallel grooves across the width of the workpiece using a slide (push) cut as shown in the figure. Then remove the workpiece material between the grooves with a chisel. Do not attempt to perform this type of cut using wide (thick) blades or with a dado blade. Possible loss of control and injury may result.

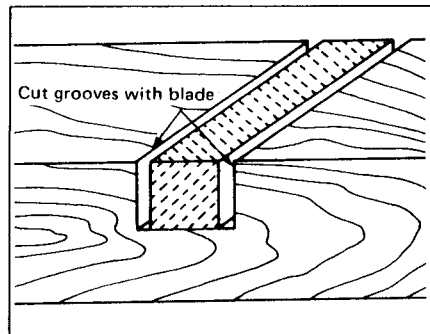
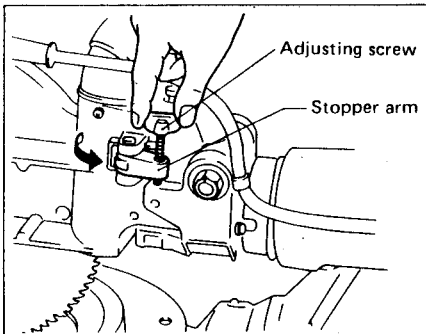

Carrying tool

Make sure that the tool is unplugged. Secure the blade at 0° bevel angle and the turn base at 60° miter angle to the right. Secure the slide pole after pulling the carriage toward you fully. Lower the handle fully and lock it in the lowered position by hooking the chain to the screw on the motor housing. Carry the tool by holding both sides of the tool base as shown in the figure. If you remove the holders, dust bag, vise, tec., you can carry the tool more easily.

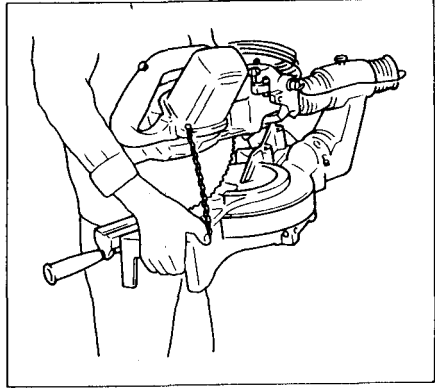

CAUTION:

Always secure all moving portions before carrying the tool.

MAINTENANCE

CAUTION:

Always be sure that the tool is switched off and unplugged before attempting to perform inspection or maintenance.

WARNING:

Always be sure that the blade is sharp and clean for the best and safest performance.

Adjusting the cutting angle

This tool is carefully adjusted and aligned at the factory, but rough handling may have affected the alignment. If your tool is not aligned properly, perform the following:

1) Miter angle

Push the carriage toward the guide fence and tighten the clamp screw on the arm to secure the carriage in the "back" position. Loosen the grip which secures the turn base. Rotate the turn base so that the pointer points to 0° on the miter scale. Then turn the turn base slightly to the left and right to seat the turn base snugly in the 0° miter notch. (Leave as it is even if the pointer does not point to 0° .) Loosen the four hex bolts which secure the guide fence using the socket wrench.

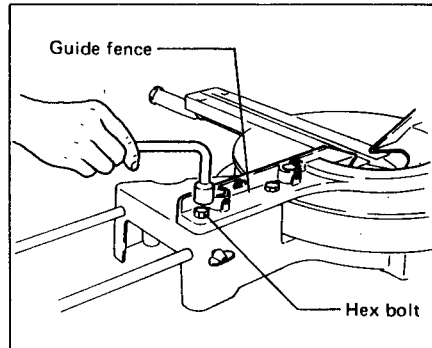

Lower the handle fully and square the side of the blade with the face of the guide fence using a triangular rule, try-square, etc. Then securely tighten the hex bolts on the guide fence in order starting from left side.

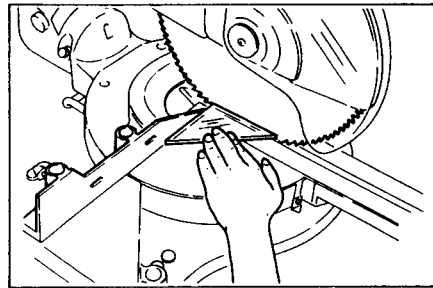

Make sure that the pointer points to 0° on the miter scale. If it does not point to 0° , loosen the screw which secures the pointer and adjust it so that it will point to 0° .

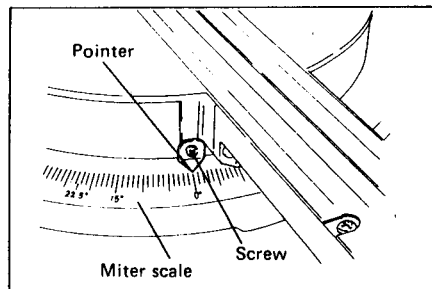

2) Bevel angle

i) 0° bevel angle

Push the carriage toward the guide fence and tighten the clamp screw on the arm. Loosen the lever at the rear of the tool. Turn the hex bolt (A) on the turn base two or three revolutions counterclockwise to tilt the blade to the right.

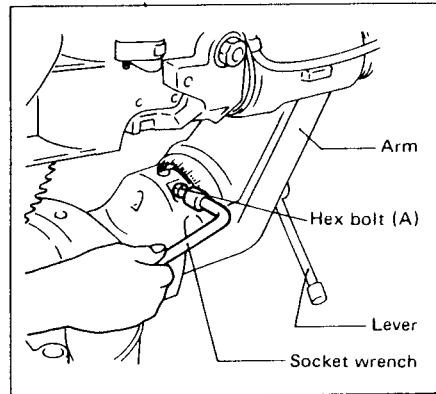

Lower the handle fully and carefully square the side of the blade with top surface of the turn base using the triangular rule, try-square, etc. by turning the hex bolt (A) clockwise. Then tighten the lever securely.

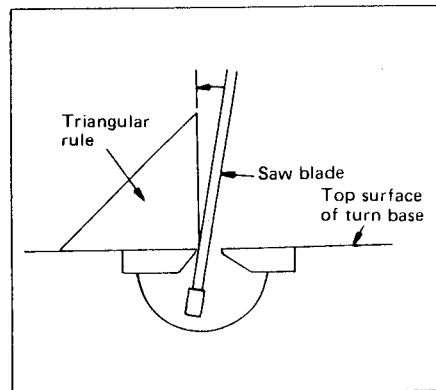

Make sure that the pointer on the arm points to 0° on the bevel scale on the arm holder. If it does not point to 0°, loosen the screw which secures the pointer and adjust it so that it will point to 0°.

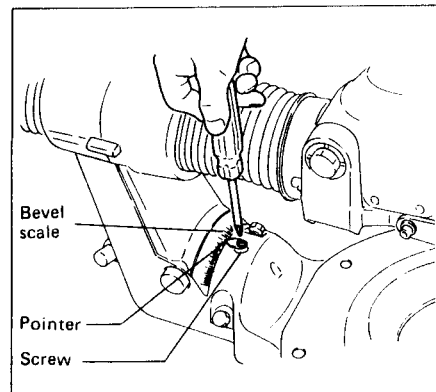

ii) 45° bevel angle

Adjust the 45° bevel angle only after performing 0° bevel angle adjustment. To adjust left 45° bevel angle, loosen the lever and tilt the blade 45° to the left. Make sure that the pointer on the arm points to 45° on the bevel scale on the arm. If the pointer does not point to 45°, turn the hex bolt (B) on the side of the turn base until the pointer points to 45°.

To adjust right 45° bevel angle, perform the same procedure described above.

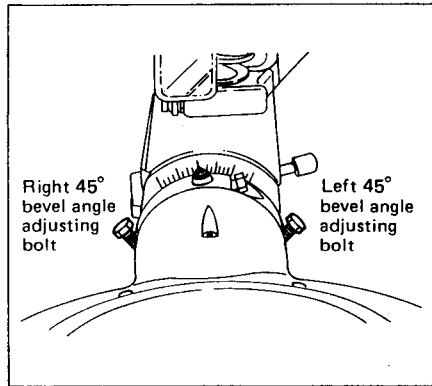

Adjusting for smooth handle action

The hex lock nut which holds the blade case and the arm together has been factory adjusted to assure smooth handle action up and down and to guarantee precise cutting. Do not tamper it. Should looseness develop at the blade case and arm connection, tighten the hex lock nut using a wrench while holding the bolt with another wrench. After adjusting the hex lock nut, be sure that the handle returns automatically to the initial, raised position from any position. If the hex lock nut is too loose, the cutting accuracy will be affected; if it is too tight, it will be difficult to work the handle up and down. Note that this is a self locking nut. It is a special type that does not loosen during normal use. It should not be overtightened or replaced with other types of nuts. The ideal amount to tighten the hex lock nut is: tight enough to just barely prevent any binding of the handle action when the handle is moved up or down.

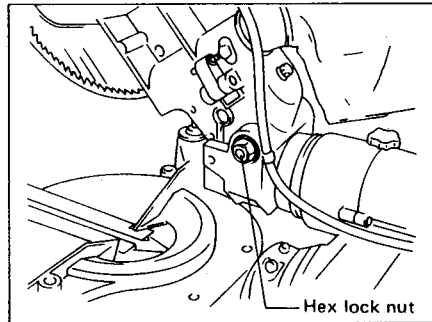

Replacing carbon brushes

Remove and check the carbon brushes regularly. Replace when they wear down to the limit mark. Keep the carbon brushes clean and free to slip in the holders. Both carbon brushes should be replaced at the same time. Use only identical carbon brushes.

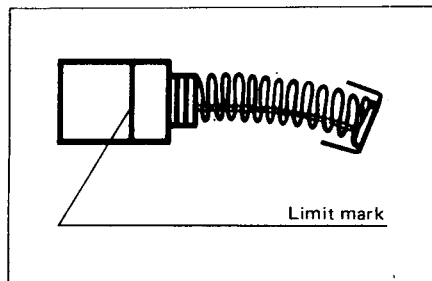

Use a screwdriver to remove the brush holder caps. Take out the worn carbon brushes, insert the new ones and secure the brush holder caps.

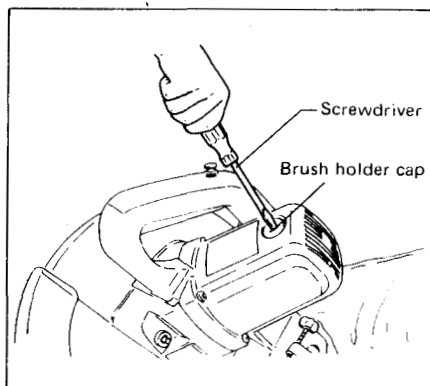

After use

After use, wipe off chips and dust adhering to the tool with a cloth or the like. Keep the safety cover clean according to the directions in the previously covered "Safety cover". Lubricate the sliding portions with machine oil to prevent rust.

To maintain product SAFETY and RELIABILITY, repairs, any other maintenance or adjustment should be performed by Makita Authorized or Factory Service Centers, always using Makita replacement parts.

OPTIONAL ACCESSORIES

The accessories listed in this manual are available at an extra cost from your Makita distributor or Makita factory service center. Service centers are listed on the warranty card packed with your tool.

CAUTION:

These accessories or attachments are recommended for use with your Makita tool specified in this manual. The use of any other accessories or attachments might present a risk of injury to persons. The accessories or attachments should be used only in the proper and intended manner.

- **Dust bag**

Part No. 122469-9



- **Socket wrench 13**

Part No. 782212-4

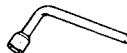

- **Holder**

Part No. 322602-5

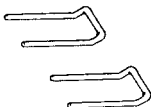

- **Set plate**

Part No. 344049-3

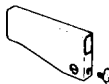

- **Triangular rule**

Part No. 762001-3



- **Lock-off button (2 pcs.)**

Part No. 411478-6



- **Holder Assembly**

Part No. 122446-1

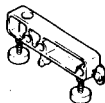

- **Vise assembly**

Part No. 122470-4



- **Carbide-tipped saw blade**

Part No. A-10665



- **Vertical vise**

Part No. 122468-1

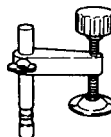

Diameter (mm)	Hole dia. (mm)	No. teeth
305 (12")	25.4 (1")	96

305 mm (12") SLIDE COMPOUND SAW Model LS1211

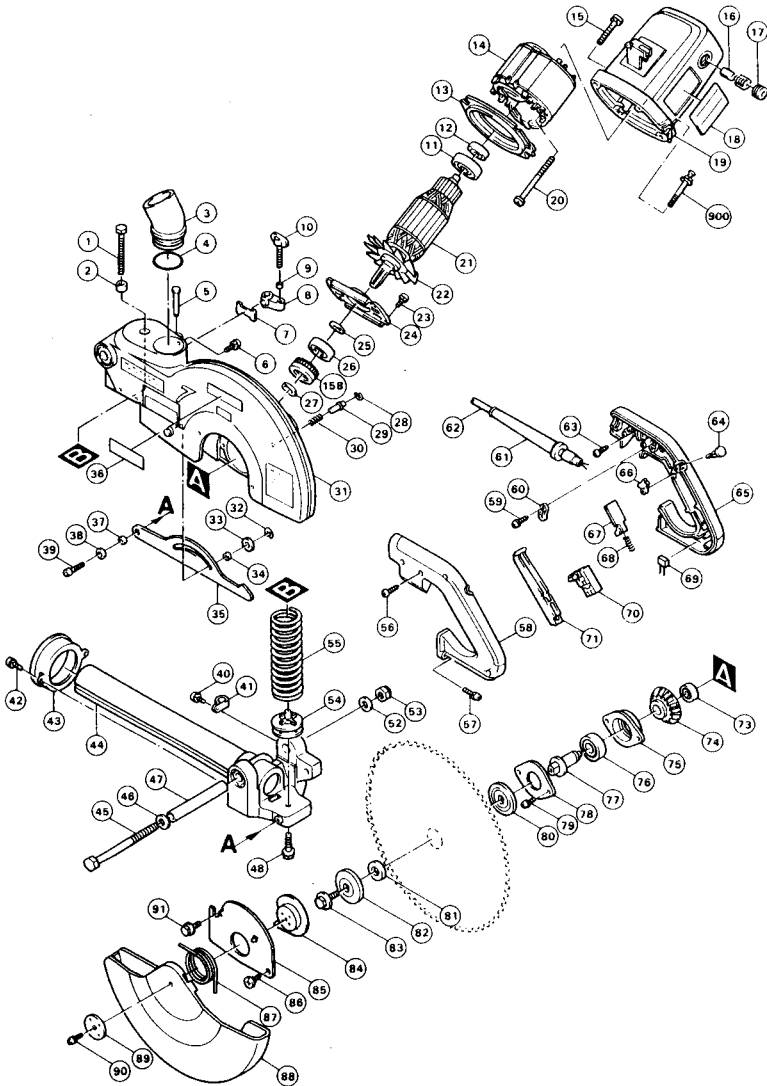

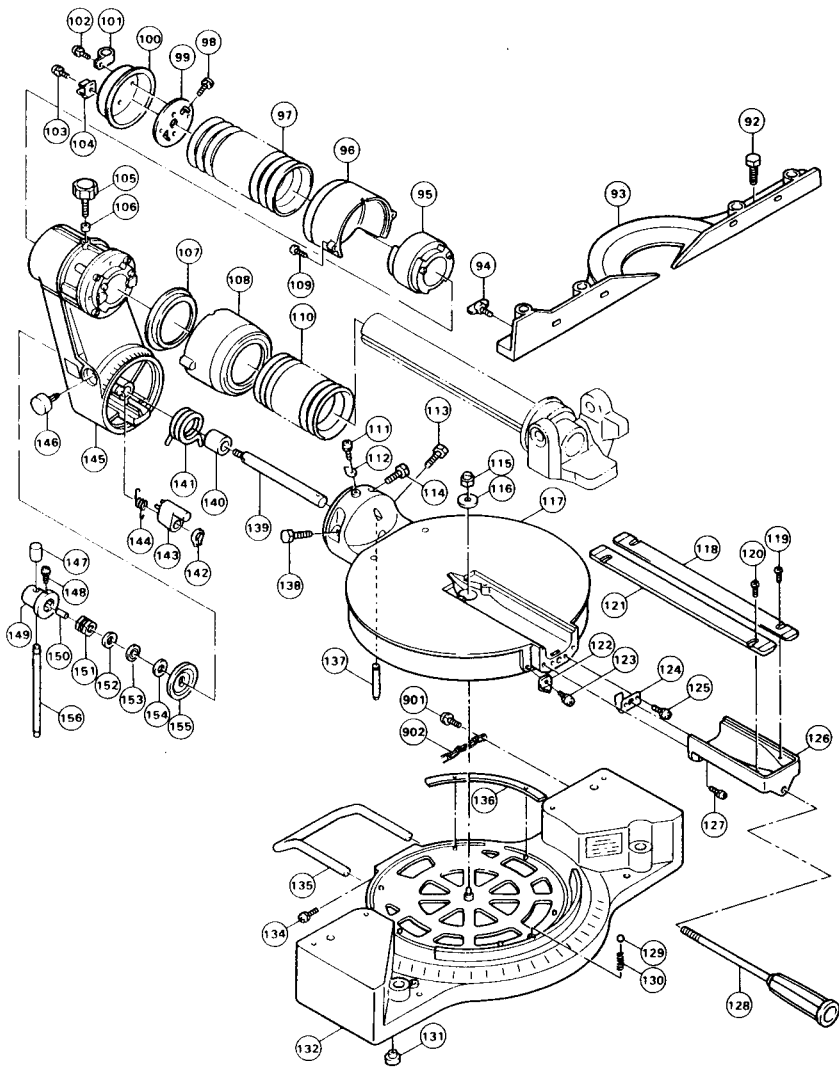

Note: The switch, noise suppressor and other part configurations may differ from country to country.

ITEM NO.	NO. USED	DESCRIPTION	ITEM NO.	NO. USED	DESCRIPTION
MACHINE			MACHINE		
1	1	Hex. Bolt M8x75	84	1	Center Plate
2	1	Rubber Sleeve 6	85	1	Center Cover
3	1	Elbow	86	1	Flat Head Screw M5
4	1	O Ring 42	87	1	Torsion Spring 45
5	1	Pin 8	88	1	Safety Cover
6	1	Pan Head Screw M4x10 (With Washer)	89	1	Flat Washer 6
7	1	Stopper Arm Plate	90	1	Pan Head Screw M5x16 (With Washer)
8	1	Stopper Arm	91	1	Hex. Flange Head Bolt M8x12
9	1	Urethane Ring 5	92	4	Hex. Bolt M8x30
10	1	Screw M6x43	93	1	Guide Rule
11	1	Insulation Washer	94	1	Screw M6x10
12	1	Ball Bearing 629LLB	95	1	Ball Spline G45
13	1	Baffle Plate	96	1	Rear Arm Cover
14	1	Field	97	1	Bellows
15	4	Pan Head Screw M6x40 (With Washer)	98	2	Pan Head Screw M4x10 (With Washer)
16	2	Carbon Brush	99	1	Rear Bellows Plate
17	2	Brush Holder Cap	100	1	Rear Bellows Cover
18	1	Name Plate	101	1	Strain Relief
19	1	Motor Housing	102	2	Pan Head Screw M4x10 (With Washer)
20	2	Pan Head Screw M5x80 (With Washer & Bond)	103	2	Pan Head Screw M4x10 (With Washer)
21	1	ARMATURE ASSEMBLY	104	1	Leaf Spring
22	1	(With Item 11, 12 & 22)	105	1	Screw M5x33
22	1	Fan 92	106	1	Urethane Ring 5
23	4	Pan Head Screw M5x16 (With Washer)	107	1	Front Bellows Plate
24	1	Bearing Retainer 92	108	1	Front Arm Cover
25	1	Flat Washer 15	109	2	Tapping Screw BT4x20
26	1	Ball Bearing 6202LLB	110	1	Bellows
27	1	Retaining Ring S - 15	111	1	Pan Head Screw M4x10 (With Washer)
28	1	Ring Spring 8	112	1	Pointer
29	1	Pin 6	113	1	Hex. Bolt M8x30
30	1	Compression Spring 7	114	1	Hex. Bolt M8x30
31	1	Blade Case	115	1	Hex. Lock Nut M8 - 13
32	1	Stop Ring E - 5	116	1	Flat Washer 8
33	1	Flat Washer 6	117	1	Turn Base
34	1	Ring 6	118	1	Kerf Board
35	1	Link Plate	119	2	Screw M4x12
36	1	Makita Mark	120	2	Screw M4x12
37	1	Ring 6	121	1	Kerf Board
38	1	Flat Washer 6	122	1	Pointer
39	1	Hex. Socket Head Bolt M6x20	123	1	Pan Head Screw M4x10 (With Washer)
40	1	Pan Head Screw M4x10 (With Washer)	124	1	Lock Plate
41	1	Strain Relief	125	2	Pan Head Screw M5x12 (With Washer)
42	2	Pan Head Screw M4x10 (With Washer)	126	1	Front Cover
43	1	Front Bellows Cover	127	2	Pan Head Screw M5x20 (With Washer)
44	1	Slide Pipe	128	1	Grip 34
45	1	Hex. Bolt M10x130	129	1	Steel Ball 7.9
46	1	Flat Washer 10	130	1	Compression Spring 6
47	1	Pipe 16 - 113	131	2	Cap 20
48	1	Hex. Bolt M8x30 (With Washer)	132	1	Base
52	1	Flat Washer 10	134	2	Pan Head Screw M5x20 (With Washer)
53	1	Hex. Lock Nut M10 - 17	135	1	Holder
54	1	Spring Holder	136	3	Slide Plate
55	1	Compression Spring 34	137	1	Pin 6
56	2	Tapping Screw BT4x20	138	1	Hex. Bolt M8x30
57	2	Pan Head Screw M5x20 (With Washer)	139	1	Lock Bolt M10
58	1	Handle Set (With Item 65)	140	1	Sleeve 17
59	2	Tapping Screw BT4x18	141	1	Torsion Spring 30
60	1	Strain Relief	142	1	Retaining Ring S - 14
61	1	Cord Guard	143	1	Stopper
62	1	Cord	144	1	Torsion Spring 15
63	1	Tapping Screw BT4x20	145	1	Arm
64	1	Lock-Off Switch Button	146	1	Release Button
65	1	Handle Set (With Item 58)	147	2	Cap 16
66	1	Cam	148	1	Pan Head Screw M5x12 (With Washer)
67	1	Lock-Off Lever	149	1	Lever Holder
68	1	Compression Spring 3	150	1	Rubber Pin 4
70	1	Switch	151	1	Hex. Nut M10 - 17
71	1	Switch Lever	152	1	Flat Washer 10
73	1	Ball Bearing 608LLB	153	1	Thrust Needle Cage 1024
74	1	Spiral Bevel Gear 39	154	1	Flat Washer 10
75	1	Bearing Box	155	1	Lock Flange
76	1	Ball Bearing 6203LLB	156	1	Lever Rod 10
77	1	Spindle	157	1	O Ring 9
78	1	Bearing Retainer 66	158	1	Rubber Ring 35
79	2	Pan Head Screw M5x16 (With Washer)	900	1	Hex. Bolt M6x40 (With Washer)
80	1	Flange 55	901	1	Pan Head Screw M6x16 (With Washer)
81	1	Ring 15.8	902	1	Chain
82	1	Flange 55			
83	1	Hex. Flange Head Bolt M10x20			

Note: The switch and other part specifications may differ from country to country.

MAKITA LIMITED ONE YEAR WARRANTY

Warranty Policy

Every Makita tool is thoroughly inspected and tested before leaving the factory. It is warranted to be free of defects from workmanship and materials for the period of ONE YEAR from the date of original purchase. Should any trouble develop during this one-year period, return the COMPLETE tool, freight prepaid, to one of Makita's Factory or Authorized Service Centers. If inspection shows the trouble is caused by defective workmanship or material, Makita will repair (or at our option, replace) without charge.

This Warranty does not apply where:

- repairs have been made or attempted by others;
- repairs are required because of normal wear and tear;
- The tool has been abused, misused or improperly maintained;
- alterations have been made to the tool.

IN NO EVENT SHALL MAKITA BE LIABLE FOR ANY INDIRECT, INCIDENTAL OR CONSEQUENTIAL DAMAGES FROM THE SALE OR USE OF THE PRODUCT. THIS DISCLAIMER APPLIES BOTH DURING AND AFTER THE TERM OF THIS WARRANTY.

MAKITA DISCLAIMS LIABILITY FOR ANY IMPLIED WARRANTIES, INCLUDING IMPLIED WARRANTIES OF "MERCHANTABILITY" AND "FITNESS FOR A SPECIFIC PURPOSE," AFTER THE ONE-YEAR TERM OF THIS WARRANTY.

This Warranty gives you specific legal rights, and you may also have other rights which vary from state to state. Some states do not allow the exclusion or limitation of incidental or consequential damages, so the above limitation or exclusion may not apply to you. Some states do not allow limitation on how long an implied warranty lasts, so the above limitation may not apply to you.

Makita Corporation of America
2650 Gainesville Hwy., Buford, GA 30518

MCA - 3/94

883860-065

PRINTED IN U.S.A.
1994-3-C

Free Manuals Download Website

<http://myh66.com>

<http://usermanuals.us>

<http://www.somanuals.com>

<http://www.4manuals.cc>

<http://www.manual-lib.com>

<http://www.404manual.com>

<http://www.luxmanual.com>

<http://aubethermostatmanual.com>

Golf course search by state

<http://golfingnear.com>

Email search by domain

<http://emailbydomain.com>

Auto manuals search

<http://auto.somanuals.com>

TV manuals search

<http://tv.somanuals.com>