

T ECHNICAL INFORMATION



PRODUCT

P 1 / 15

Models No. ▶ BTW074, BTW104

Description ▶ Cordless Impact Wrench

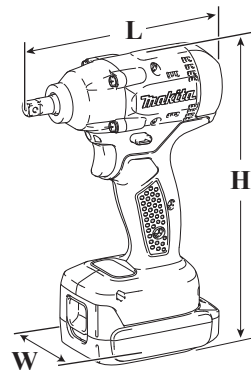

(The image above is Model BTW074.)

Dimensions: mm (")	
Length (L)	144 (5-5/8)*1
Width (W)	74 (2-15/16)
Height (H)	216 (8-1/2)*1/ 234 (9-1/4)*2

*1 149mm (5-7/8") for Anti-wobble anvil version

*2 with 1.5Ah Li-ion battery BL1415NA

*3 with 3.0Ah Li-ion battery of BL1430A

CONCEPT AND MAIN APPLICATIONS

These cordless impact wrenches for manufacturing industry as the successors of BTW072 series models.

Their main features are:

- Extra compact design with a short overall length of 144mm (5-5/8")*1
- Powered by our new 14.4V Li-ion batteries with battery fuel gauge:
BL1415NA (1.5Ah)/ BL1415NP (1.5Ah)/
BL1430A (3.0Ah)/ BL1430AP (3.0Ah)
- Automatic impact stop system to avoid under-tightening and over-tightening
- Torque stabilization system to stabilize the torque of each fastening
- Automatic battery shut-off system to avoid incomplete fastenings

► Specification

Model No.		BTW074	BTW104
Battery	Cell	Li-ion	
	Voltage: V	14.4	
	Capacity: Ah	1.5/ 3.0	
	Energy capacity: Wh	22/ 44	
	Charging time (approx.): min.	15/ 22 with DC18RC	
Max output (W)		140	150
Driving shank		9.5mm (3/8") Square drive	
Capacities	Standard bolt	M5 - M12 (3/16 - 1/2")	
	High tensile bolt	M5 - M10 (3/16 - 3/8")	
Impacts per min.: min. ⁻¹ =ipm		0 - 3,500	
No load speed: min. ⁻¹ =rpm		0 - 2,500	0 - 2,700
Max. fastening torque: N.m [kgf·cm] (in.lbs)		65 [660] (575)*4	95 [970] (841)*5
Battery fuel gauge*6		Yes	
Automatic battery shut-off system		Yes	
Electric brake		Yes	
LED job light		Yes	
Variable speed control by trigger		Yes	
Reverse switch		Yes	
Weight according to EPTA-Procedure 01/2003*7: kg (lbs)		1.1/ 1.3	(2.4/ 2.9)

*4 The fastening torque at 3 seconds after seating, when fastening M10 (grade 10.9) high tensile bolt.

*5 The fastening torque at 3 seconds after seating, when fastening M12 (grade 10.9) high tensile bolt.

*6 located on battery BL1415NA/ BL1415NAP/ BL1430A/ BL1430AP, not on the tool body

*7 with battery

► Standard equipment

No

► Optional accessories

Li-ion Battery BL1415NA
Li-ion Battery BL1415NAP
Li-ion Battery BL1430A
Li-ion Battery BL1430AP
Battery protector
Charger DC18SD

Charger DC24SC
Automotive charger DC18SE
Fast charger DC18RA (for USA, Canada, Guam, Panama, Mexico, Colombia)
Fast charger DC18RC (for all countries except the countries above)
Protectors (blue/ white/ red)
Automatic refreshing adapter ADP03

► Repair

CAUTION: Repair the machine in accordance with “Instruction manual” or “Safety instructions”.

[1] NECESSARY REPAIRING TOOLS

Code No.	Description	Use for
1R004	Retaining Ring S Pliers	disassembling / assembling Ring spring 7
1R045	Gear extractor	disassembling / assembling Hammer section
1R222	Socket Adapter	securing Ring spring 7
1R288	Screwdriver magnetizer	removing Steel ball 5.6 from Spindle

[2] LUBRICATION

Apply **Makita grease FA No.2** to the following portions designated with the black triangle to protect parts and product from unusual abrasion.

Item No.	Description	Portion to lubricate	Amount
⑭	Anvil	Drum portion which is accepted by Needle bearing 1412 mounted in Hammer case complete	a little
⑯	Steel ball 3.5 (24 pcs.)	Whole portion	a little
⑳	Spindle	(a) Tip portion which is inserted into ⑭ Anvil	a little
		(b) in the hole where Spur gear 16 engages with Armature's gear	approx. 2 g
㉕	Steel ball 5.6 (2 pcs.)	Whole portion	a little

Fig. 1

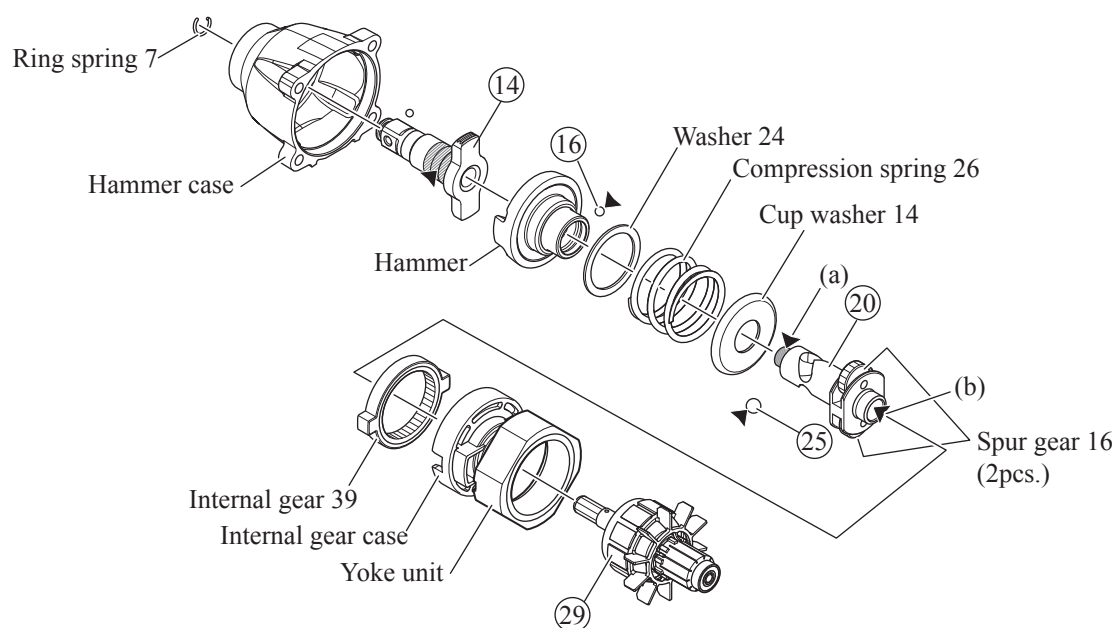

► Repair

[3] DISASSEMBLY/ASSEMBLY

[3] -1. Note for Assembly/Disassembly

The models can be distinguished depending on the max. fastening torque. See **Fig. 2**.

Fig. 2

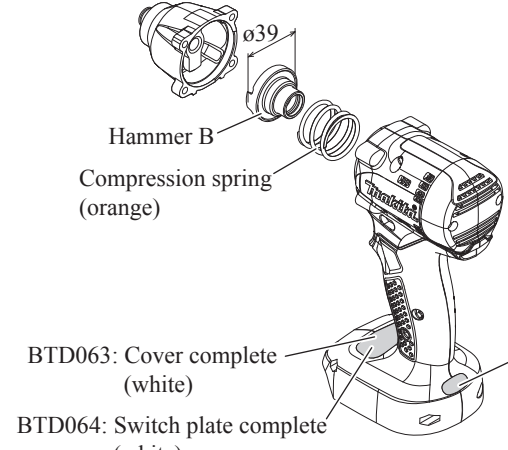
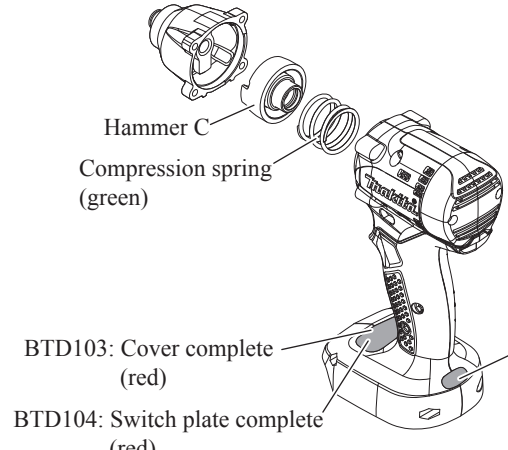
Max. fastening torque	Model No.	Distinctive Parts
65 N.m	BTW073 BTW074	 <p>Hammer B Compression spring (orange)</p> <p>BTD063: Cover complete (white) BTD064: Switch plate complete (white)</p> <p>ID plate (white)</p> <p>ø39</p>
95 N.m	BTW103 BTW104	 <p>Hammer C Compression spring (green)</p> <p>BTD103: Cover complete (red) BTD104: Switch plate complete (red)</p> <p>ID plate (red)</p>

When repairing the products, be sure to assemble Hammer, Compression spring and Switch plate complete or Cover complete as shown in **Fig.2**.

► **Repair**

[3] DISASSEMBLY/ASSEMBLY

[3] -2. Armature

DISASSEMBLING

(1) Remove Armature section from Housing set as drawn in **Fig. 3**, and remove Brush holder from Armature in **Fig. 4**.

Fig. 3

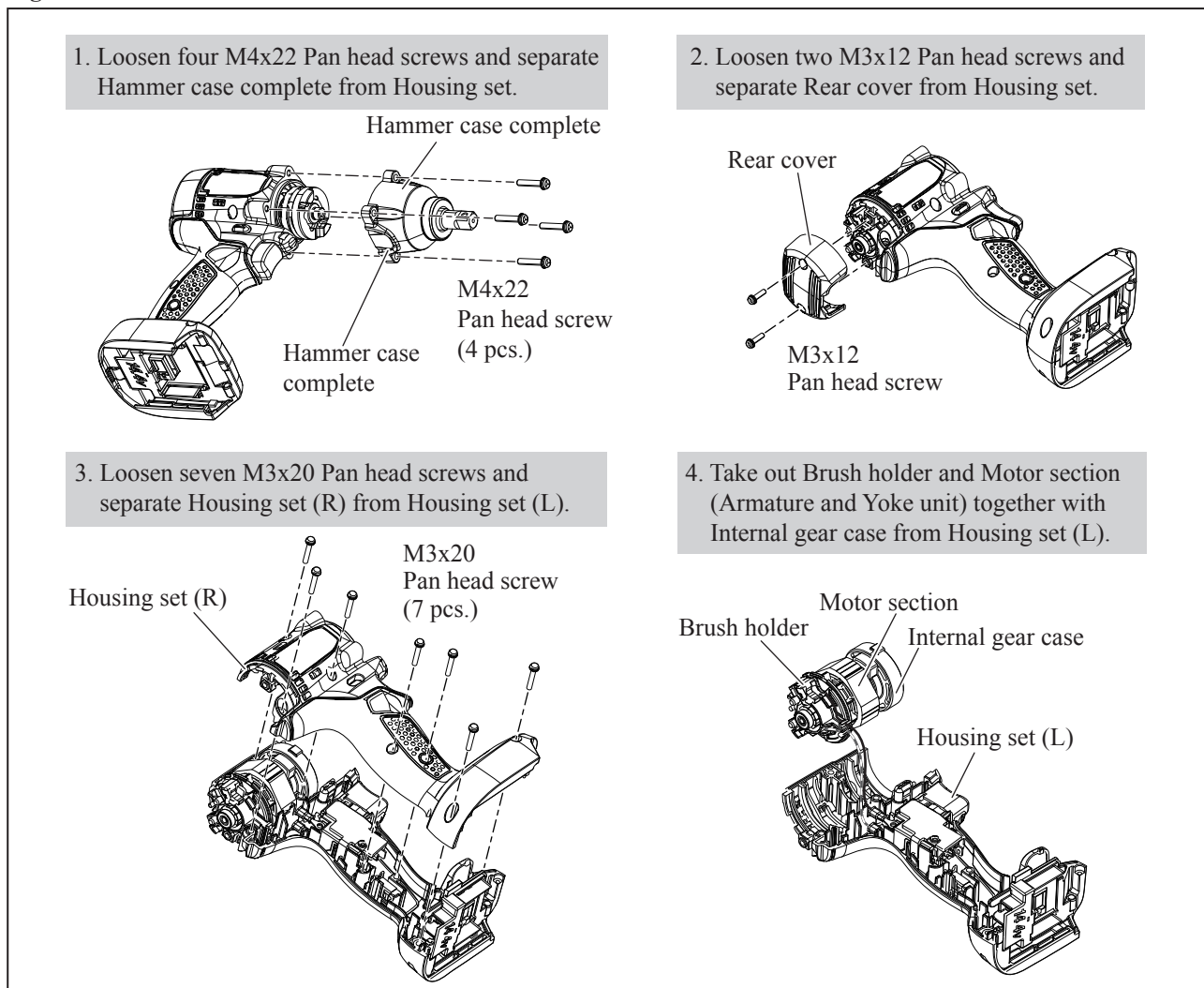
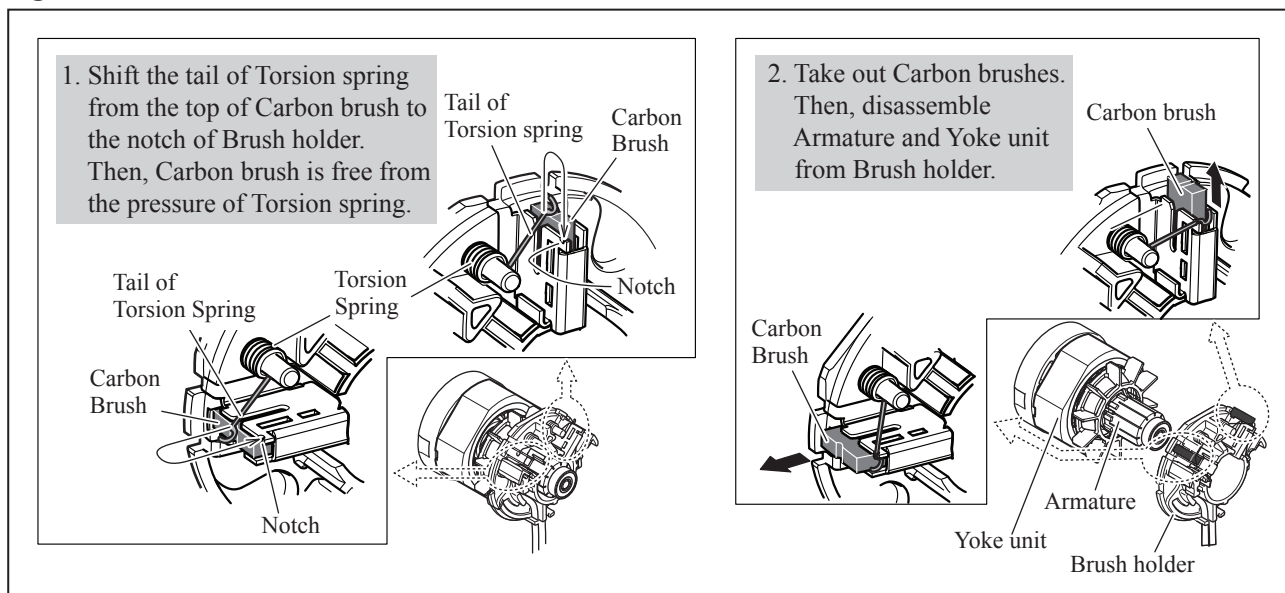

Fig. 4



► Repair

[3] DISASSEMBLY/ASSEMBLY

[3] -2. Armature (cont.)

DISASSEMBLING

(1) Remove Armature as drawn in **Fig. 5**.

Fig. 5

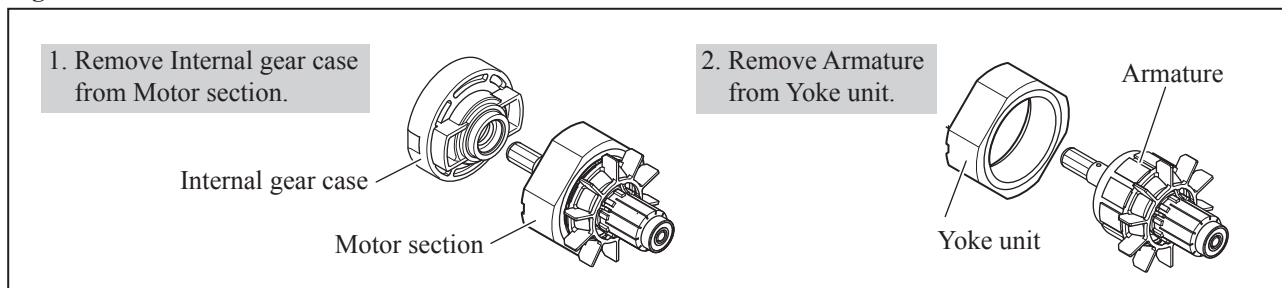

ASSEMBLING

(1) Insert Armature into Yoke unit so as not to damage the wiring of Armature and not to be pinched your fingers between yoke unit and Armature fan. And insert the drive end of Armature into Internal gear case as drawn in **Fig. 6**.

Fig. 6

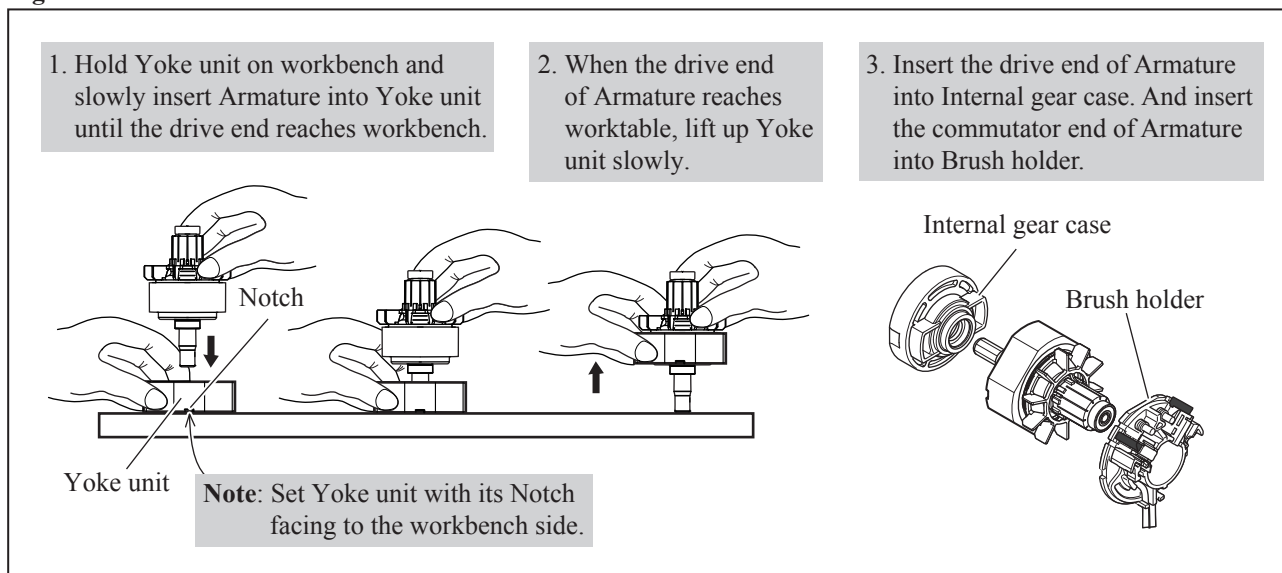

(2) Assemble Motor section (Armature, Yoke unit), Internal gear case and Brush holder as drawn in **Fig. 7**.

Fig. 7

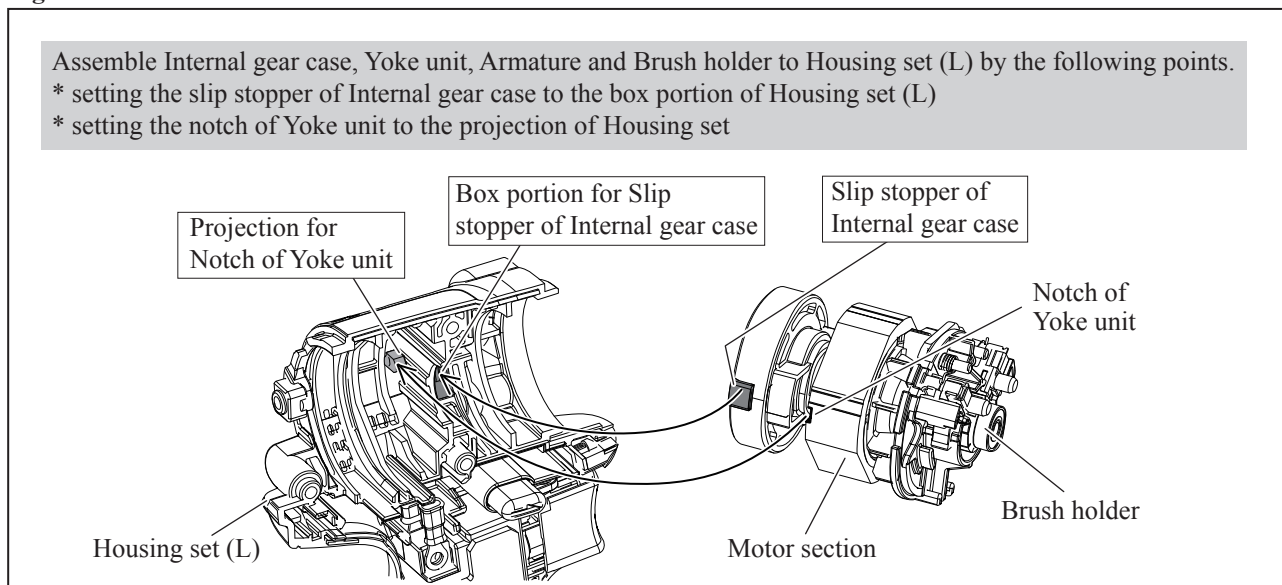

► Repair

[3] DISASSEMBLY/ASSEMBLY

[3] -2. Armature (cont.)

ASSEMBLING

(3) Assemble Motor section (Armature, Yoke unit), Internal gear case and Brush holder to Housing set (L) as drawn in Fig. 8.

Fig. 8

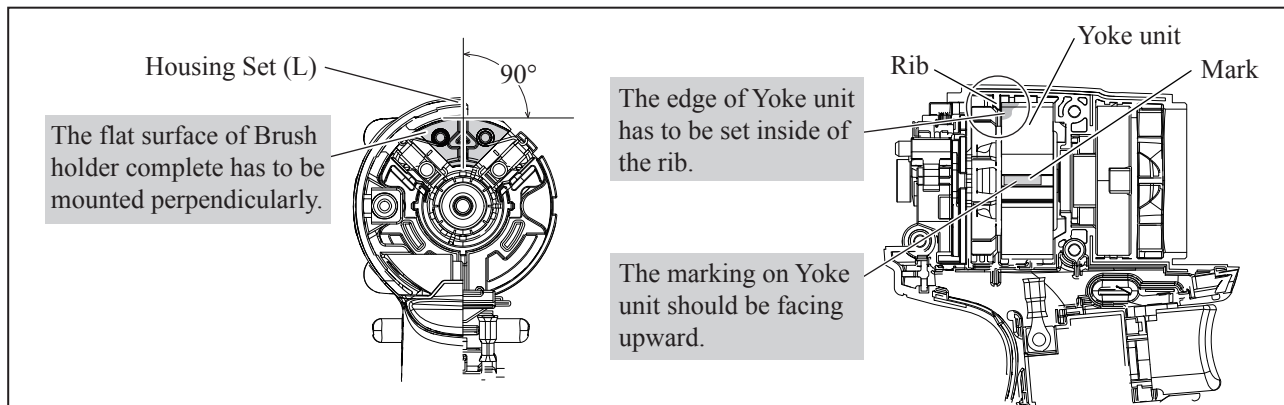

(4) Mount Pig tails and Spacers as drawn in Fig. 9.

Fig. 9

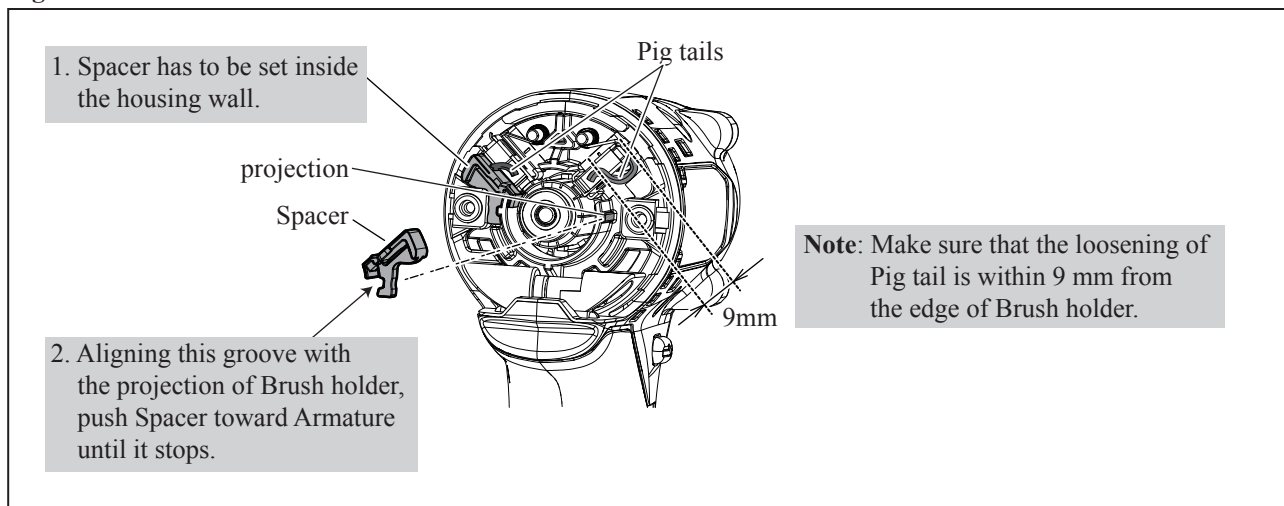

(5) Assemble F/R change lever as drawn in Fig. 10.

Fig. 10

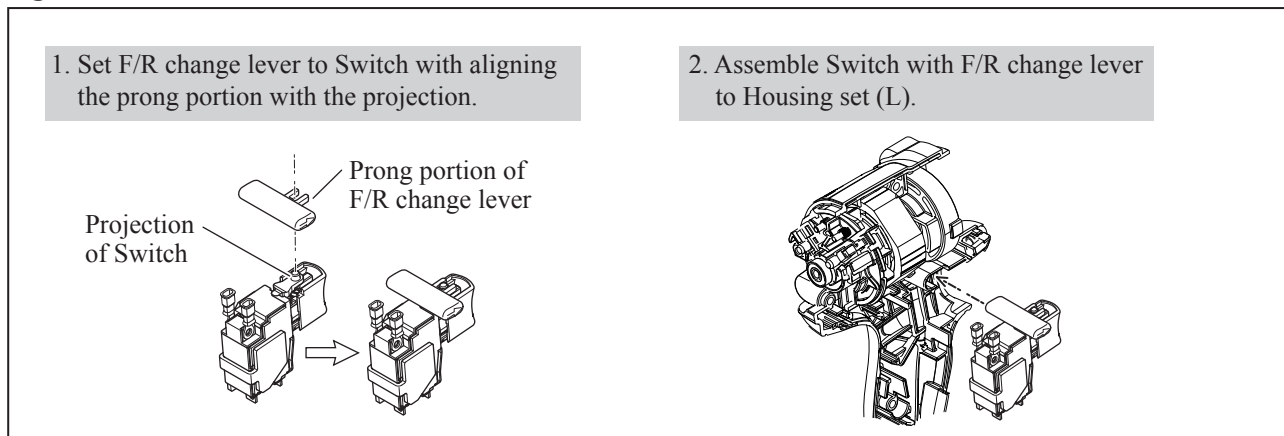

(6) Be sure to assemble ID plate and Cover complete or Switch plate complete to Housing set (L) in accordance with [3] -1. **Note for Assembly/Disassembly** and the drawings in Fig. 2. And then, assemble Housing set (R).

► Repair

[3] DISASSEMBLY/ASSEMBLY

[3] -3. Ball bearing 6801LLB in Internal gear case

DISASSEMBLING

- (1) Disassemble Brush holder and Motor section together with Internal gear case as drawn in **Fig. 3**.
- (2) Remove Internal gear case from Armature as drawn on the left in **Fig. 5**.
- (3) Remove Ball bearing 6801LLB from Internal gear case as drawn in **Fig. 11**.

Fig. 11

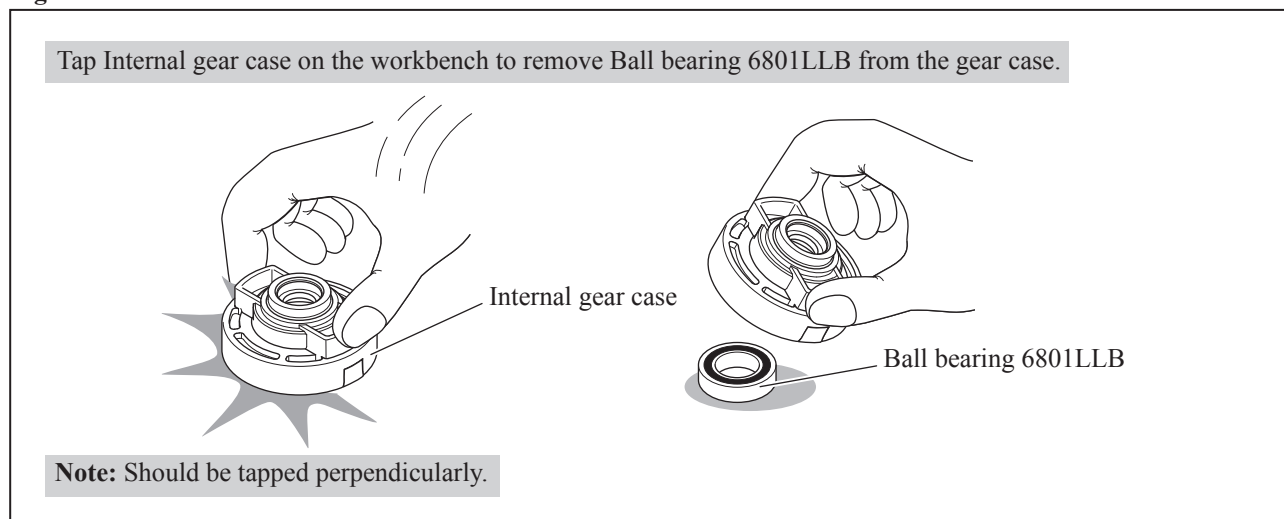

► Repair

[3] DISASSEMBLY/ASSEMBLY

[3] -4. Bit holder section, Anvil

DISASSEMBLING

- (1) Loosen four M4x22 Pan head screws and separate Hammer case complete from Housing set.
See the drawing on the upper left in **Fig. 3**.
- (2) Remove Ring spring 7 as drawn in **Fig. 12**. And then, remove Anvil as drawn in **Fig. 13**.
*For Anvil without Ring spring 7, Anvil can be removed as drawn in **Fig. 13** skipping **Fig. 12**.

Fig. 12

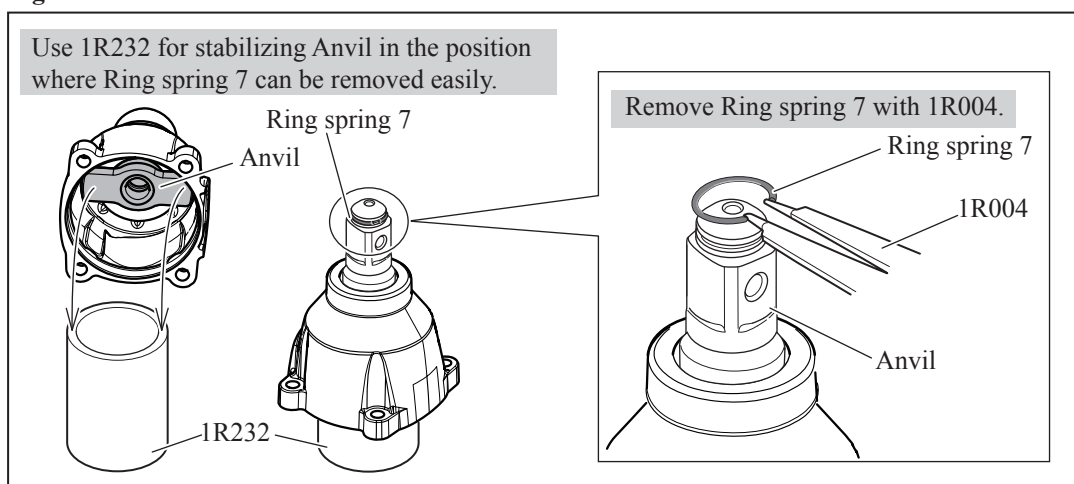
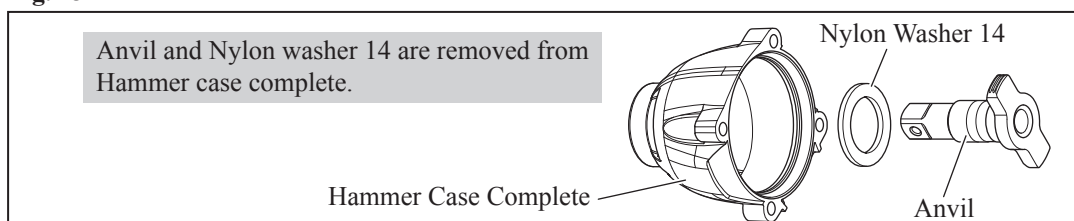

Fig. 13



ASSEMBLING

- (1) Pass Anvil through Nylon Washer 14 and mount them to Hammer case complete. Refer to **Fig. 13**.
*For Anvil without Ring spring 7, Hammer case section can be assembled to Housing set. Refer to **Fig. 3**.
- (2) To stabilize Anvil in the position where Ring spring 7 can be assembled easily, set Hammer case complete on 1R232. Refer to the drawing on the left in **Fig. 12**.
- (3) Assemble Ring spring 7 as drawn in **Fig. 14**.

Fig. 14

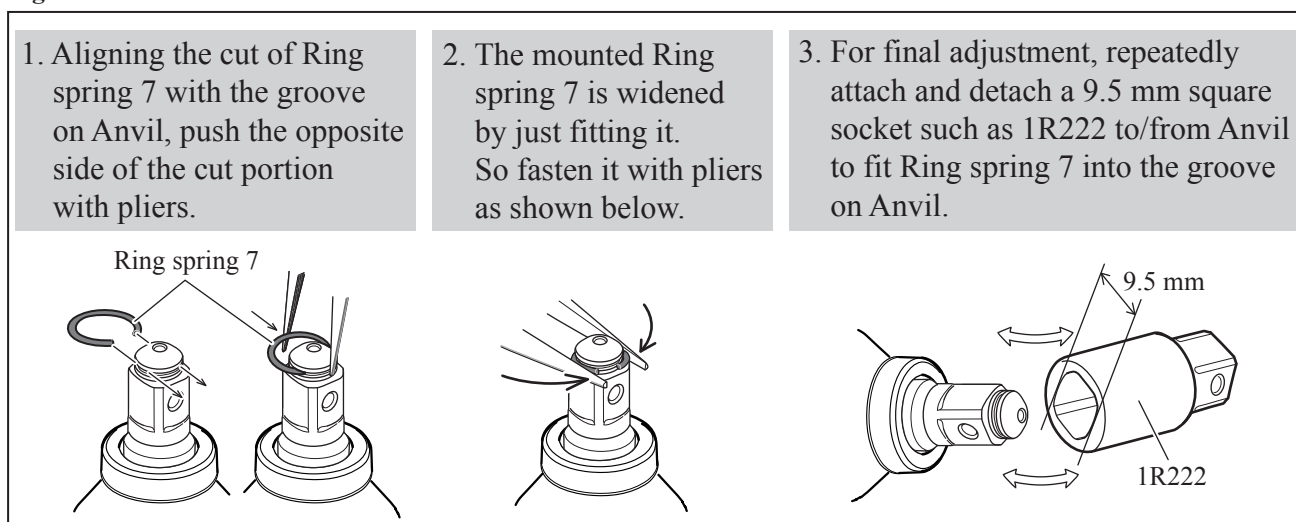

► Repair

[3] DISASSEMBLY/ASSEMBLY

[3] -5. Hammer section

DISASSEMBLING

- (1) Loosen four M4x22 Pan head screws and separate Hammer case complete from Housing set.
See the drawing on the upper left in **Fig. 3**.
- (2) Remove Hammer section from Housing set. See **Fig. 15**.

Fig. 15

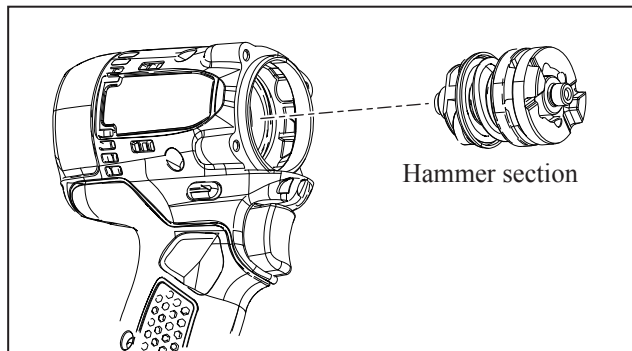

- (3) Take out Steel ball 5.6 with 1R045 as drawn in **Fig. 16**.

Fig. 16

1. Pull Hammer downwards using 1R045 to align the opening for Steel ball insertion with the top of the cam grooving on Spindle, and then remove Steel balls 5.6 from Spindle.

2. Hold Hammer section as shown below in **Fig. 16R**, and then release it from 1R045.

Caution: Do not hold Hammer section as shown below in **Fig. 16F** when releasing Hammer section from 1R045. Failure to follow this instruction could cause Steel balls 3.5 to fall out from it.

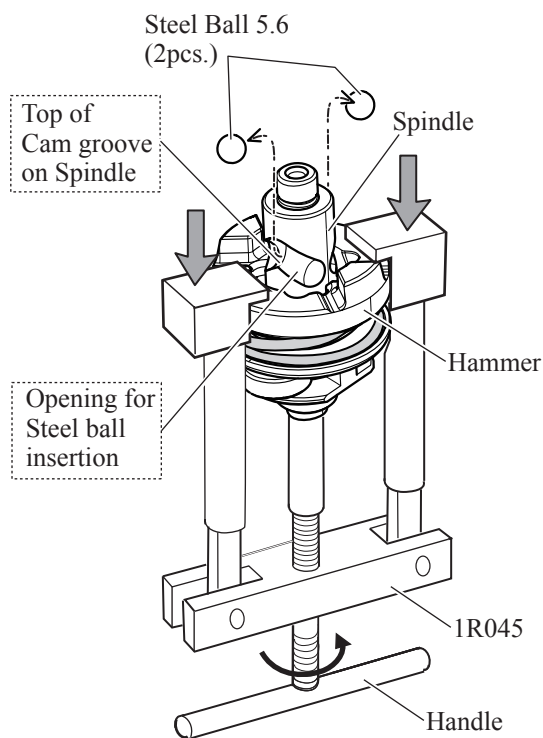

Fig. 16R

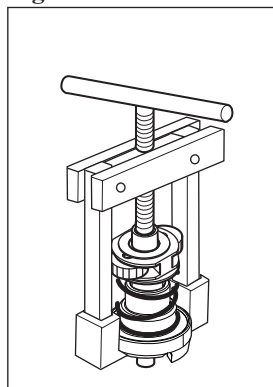
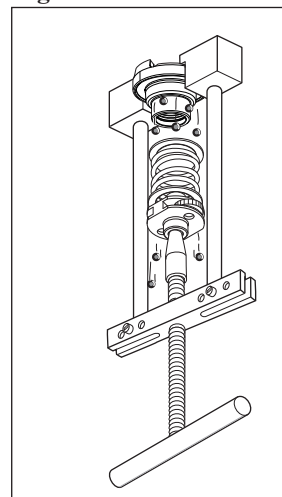

Fig. 16F



► **Repair**

[3] **DISASSEMBLY/ASSEMBLY**

[3] **-5. Hammer section (cont.)**

DISASSEMBLING

(4) Disassemble Hammer section as drawn in **Fig. 17**.

Fig. 17

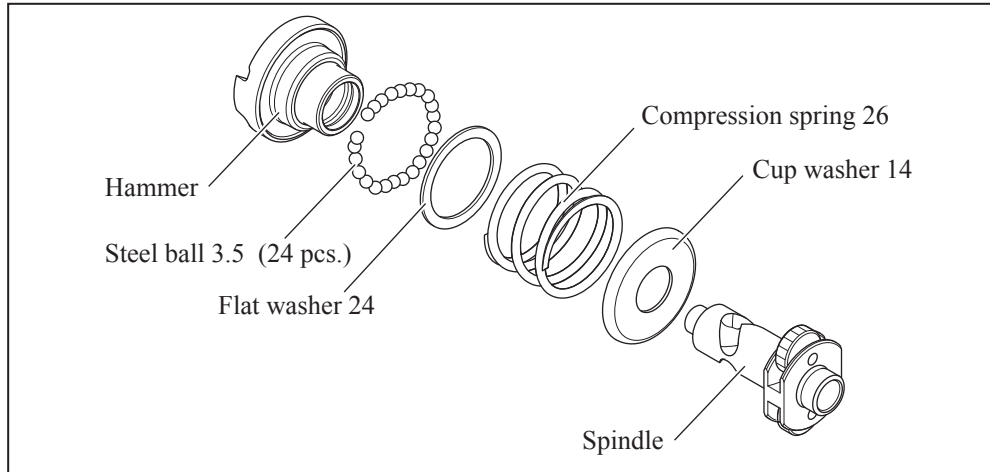

ASSEMBLING

Assemble Hammer section by reversing the disassembly procedure. (Refer to **Fig. 17**)

Note for Assembling:

Before putting Flat washer 24 in Hammer, make sure that twenty-four Steel balls 3.5 are put in the groove of Hammer as shown in **Fig. 18**.

Fig. 18

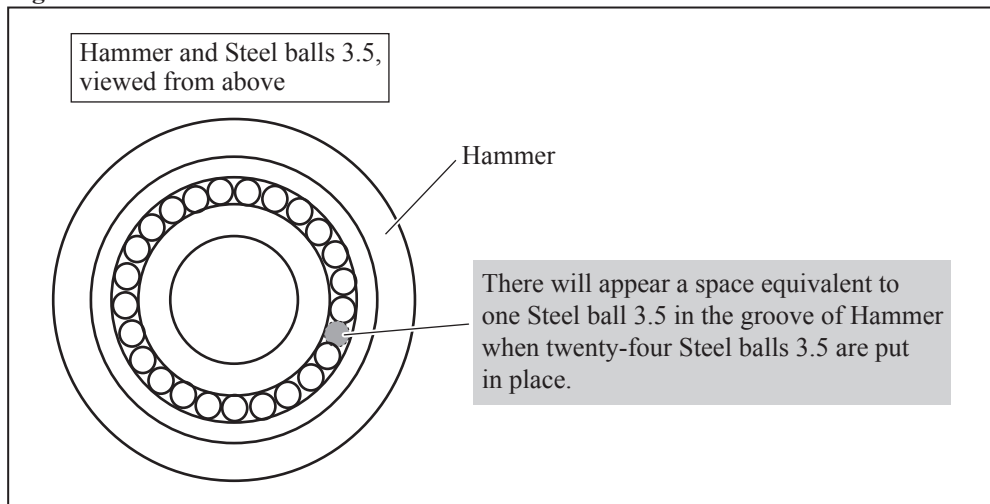

► **Circuit diagram**

BTW073, BTW103
(without Automatic Impact Stop System)

Fig. D-1

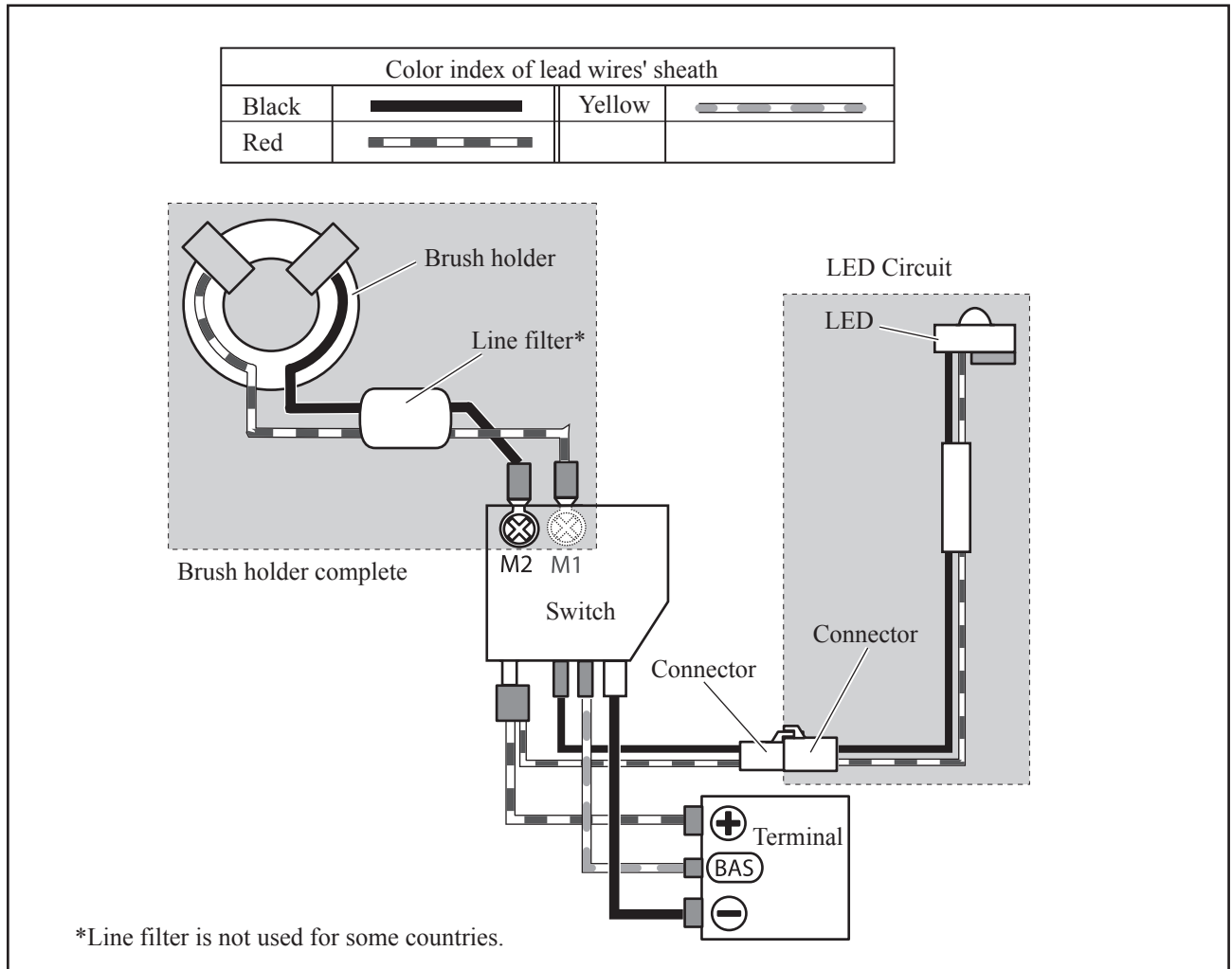

► **Wiring diagram**

BTW073, BTW103
(without Automatic Impact Stop System)

Fig. D-2

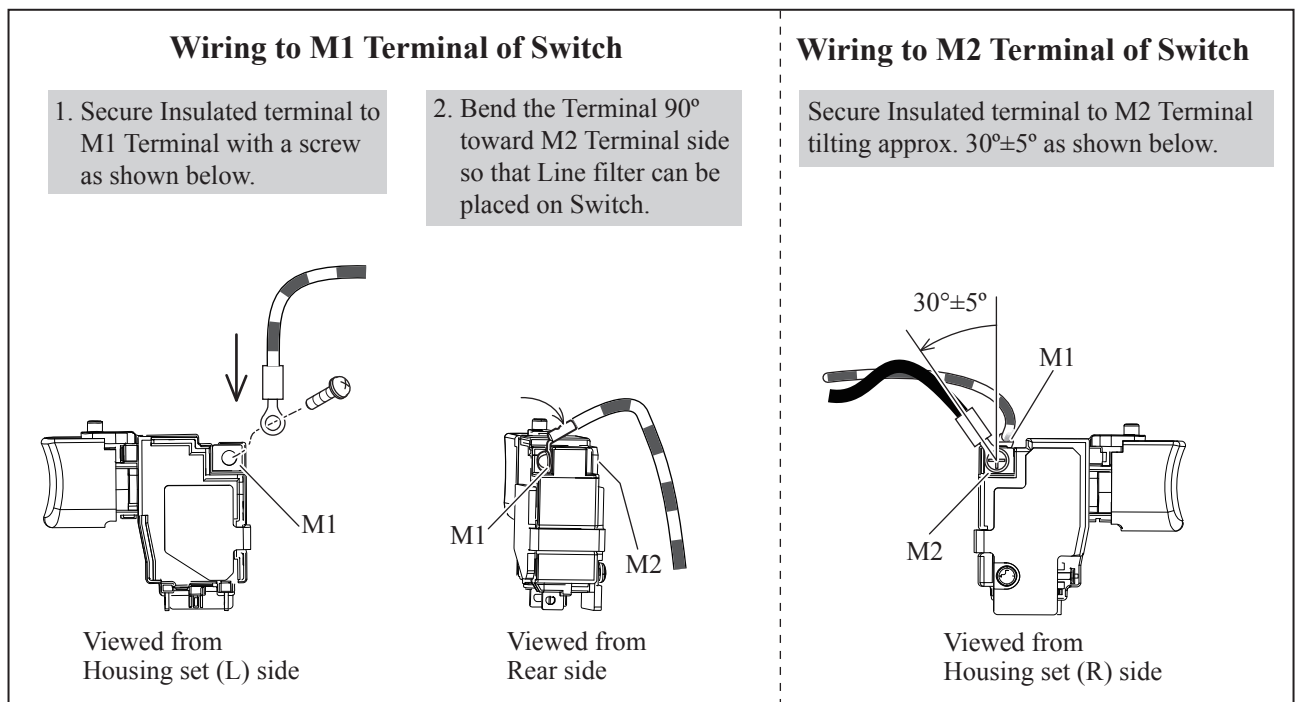

► **Wiring diagram**

BTW073, BTW103
(without Automatic Impact Stop System)

Fig. D-3

Wiring of LED Lead Wire (before setting Switch)

Route Lead wires (black, red) between Rib A and the inner wall of Housing set (L).

Route lead wires (black, red) between Rib A and Rib B so that they are not pinched with Switch.

Route Lead wires (black, red) between Rib B and the inner wall of Housing set (L).

If Connectors are put in Connector box A, route Lead wires (black, red) through Connector box A and secure them with Lead wire holder A .

Connectors in Connector Box A

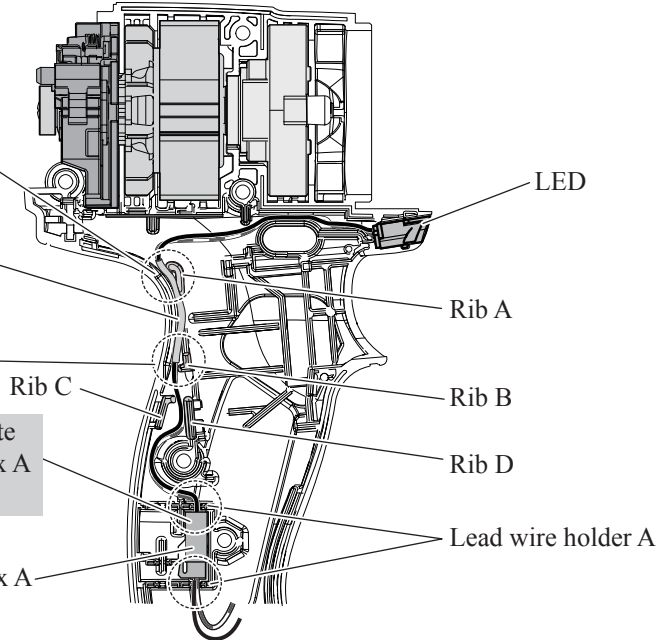

Connectors in Connector box B

Lead wire holder B

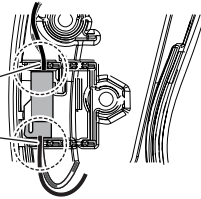

Connectors can be also routed through Connector box B. In this case, Lead wires have to be secured with Lead wire holder B.

Wiring in Housing set (L) (after setting Switch)

Be careful not to route any Lead wires on this Rib.

Rib E
Line filter

Place Line filter between Rib E and Rib F.

Note for Wiring:

If Line filter interferes with Housing set (R) in assembling, check that Insulated terminal is tilted enough to save the space for Line filter referring to **Fig. D-2**.

Route Lead wires connected to Switch between Boss and the inner wall of Housing set (L).

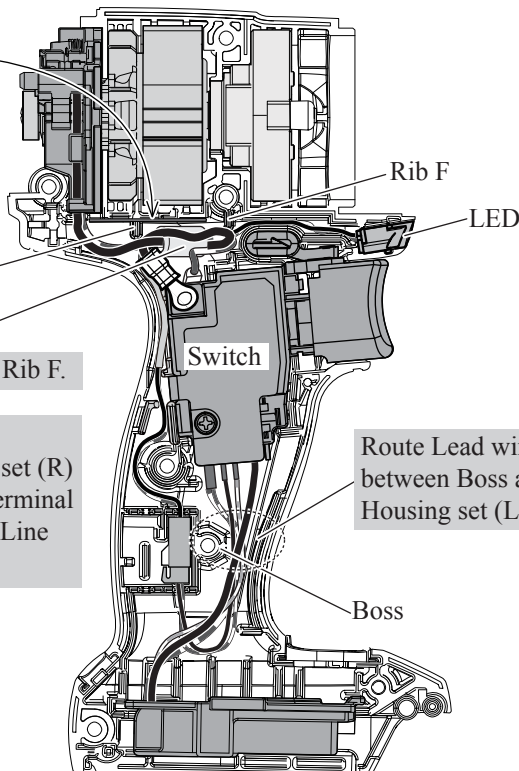

► **Circuit diagram**

BTW074, BTW104
(equipped with Automatic Impact Stop System)

Fig. D-4

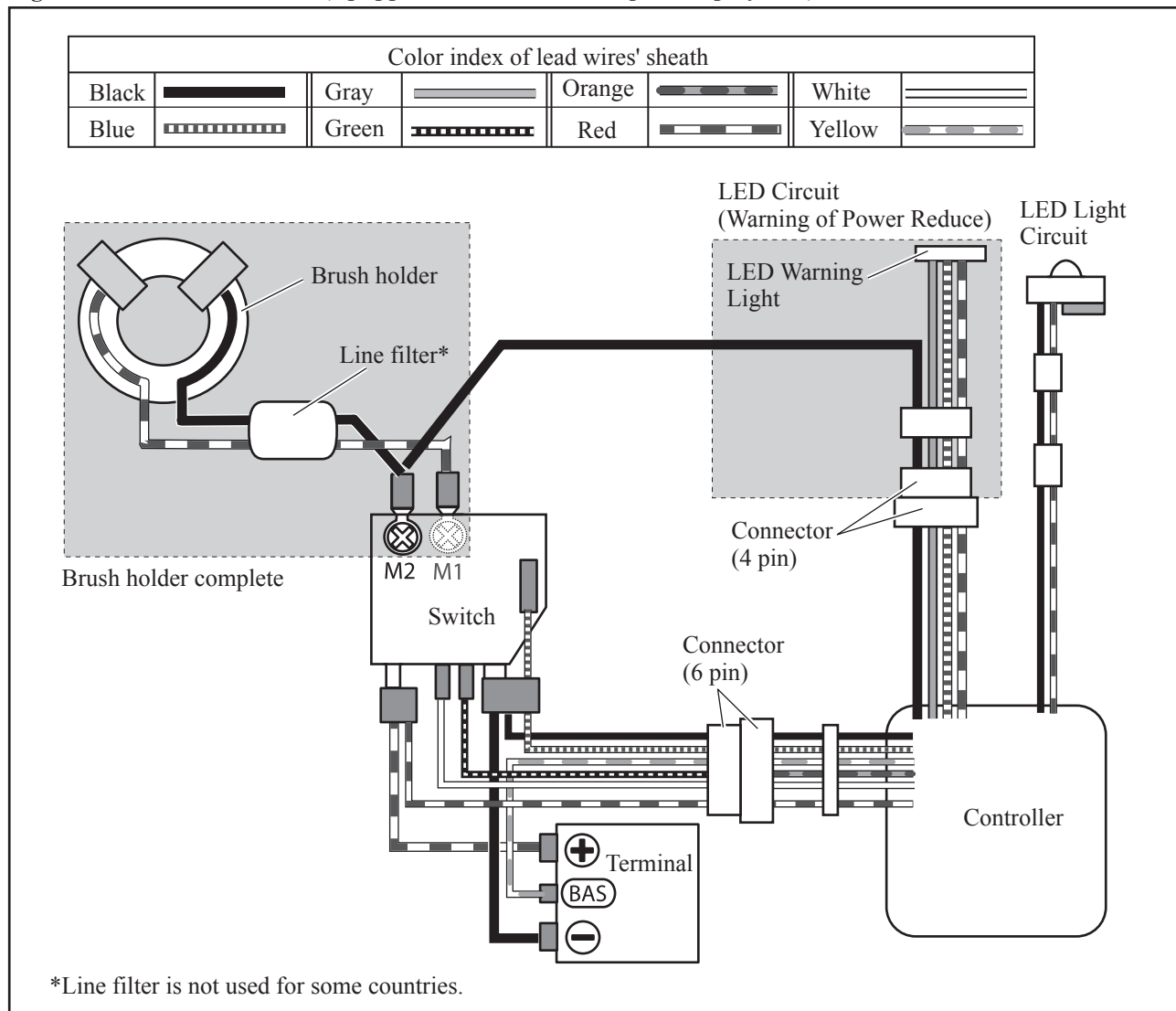

► **Wiring diagram**

BTW074, BTW104
(equipped with Automatic Impact Stop System)

Fig. D-5

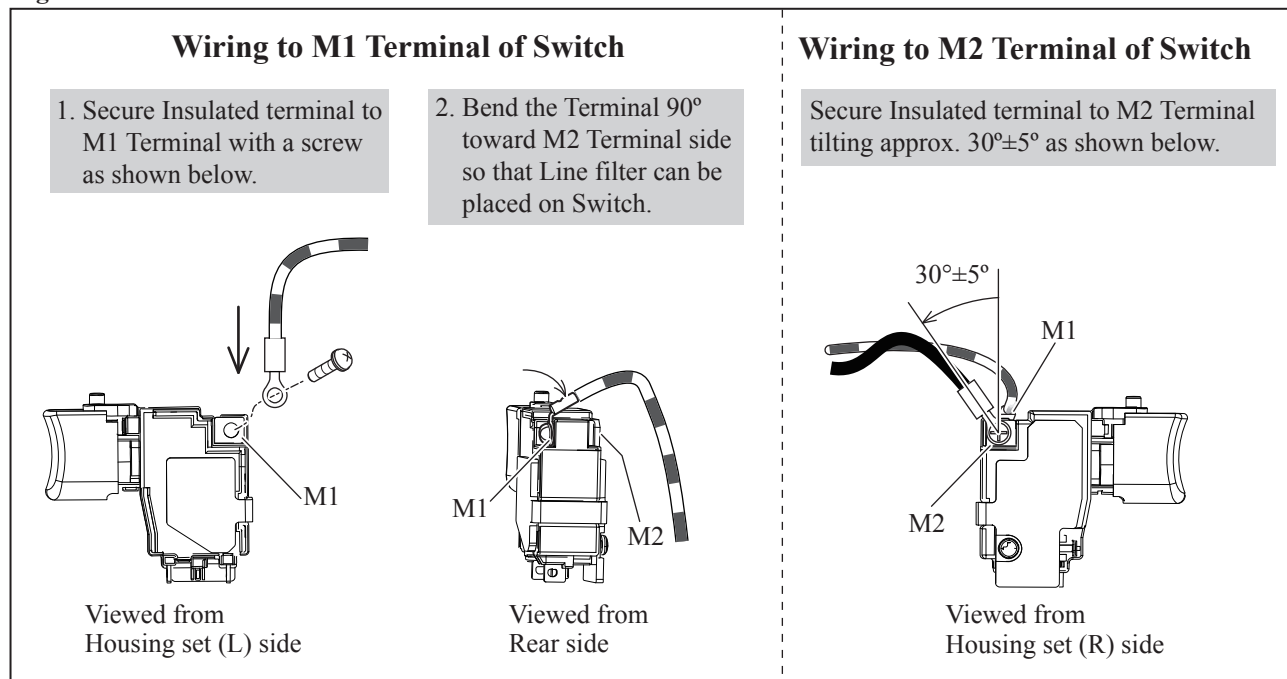

► **Wiring diagram**

BTW074, BTW104
(equipped with Automatic Impact Stop System)

Fig. D-6

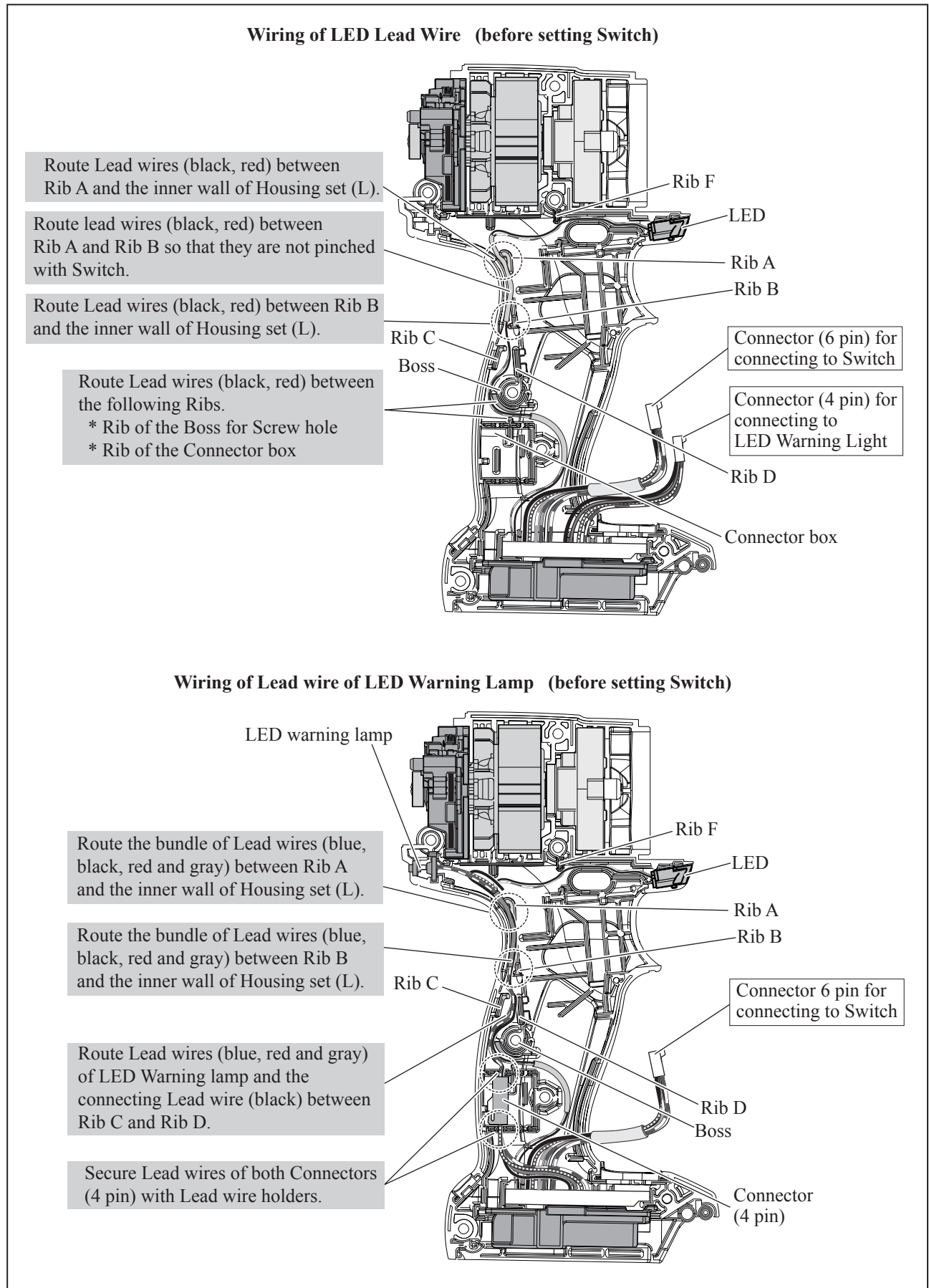

► **Wiring diagram**

BTW074, BTW104
(equipped with Automatic Impact Stop System)

Fig. D-7

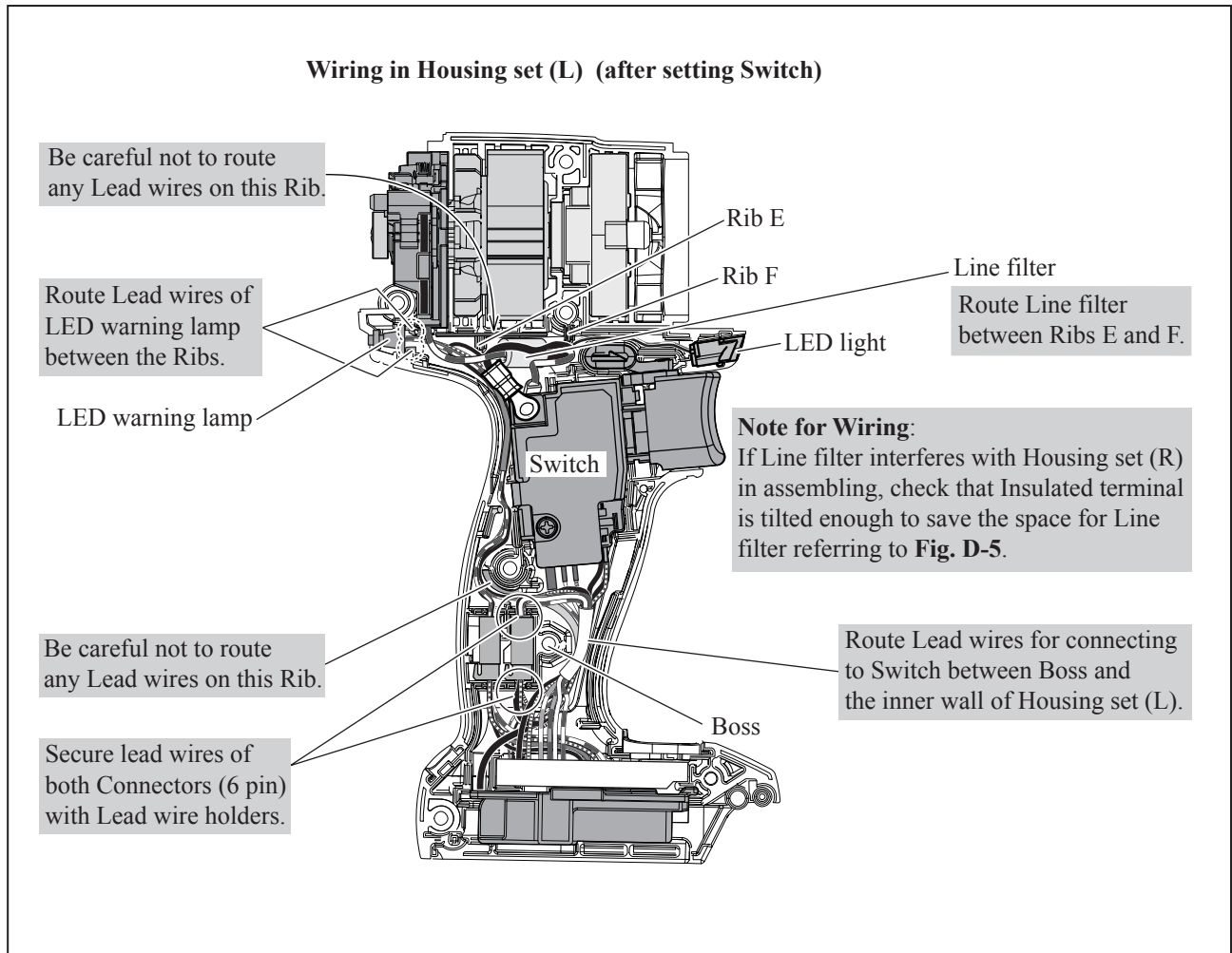

Free Manuals Download Website

<http://myh66.com>

<http://usermanuals.us>

<http://www.somanuals.com>

<http://www.4manuals.cc>

<http://www.manual-lib.com>

<http://www.404manual.com>

<http://www.luxmanual.com>

<http://aubethermostatmanual.com>

Golf course search by state

<http://golfingnear.com>

Email search by domain

<http://emailbydomain.com>

Auto manuals search

<http://auto.somanuals.com>

TV manuals search

<http://tv.somanuals.com>