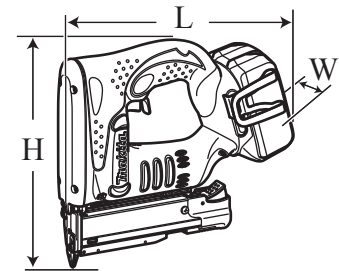


# TECHNICAL INFORMATION

**Models No.** ▶ BPT351 (LXTP01\*1)

**Description** ▶ Cordless Pin Nailer  
\*1 Model number for North and Central American countries



## CONCEPT AND MAIN APPLICATIONS

Model BPT351 has been developed as a 18V Cordless Pin Nailer with more working capacity than that of 14.4V Model BPT350. Its features and benefits are the same as BPT350 except for 18V Li-ion battery.

This model is available in the following variations.

Model No.	Charger	Battery		Plastic carrying case	Systainer case
		Type	Quantity		
BPT351RFE (LXTP01)	DC18RA	BL1830	2	Yes	No
BPT351RFX				No	Yes
BPT351Z (LXTP01Z)	No	No	No	No	No
BPT351ZX					Yes

Dimensions: mm (")	
Length (L)	249 (9-3/4)
Width (W)	79 (3-1/8)
Height (H)	227 (8-15/16)

All models also include the accessories listed below in "Standard equipment".

### ► Specification

Specifications		Model No.	BPT351 (LXTP01)
Battery	Voltage: V		18
	Capacity: Ah		1.3/ 3.0
	Energy capacity: Wh		24/ 54
	Cell		Li-ion
	Charging time: min.		22 with DC18RA
Pin nails (23Ga)	Length: mm (")		18, 25, 30, 35 (11/16, 1, 1-3/16, 1-3/8)
	Diameter: mm (")		0.6 (1/32)
Magazine capacity: pcs.			130
Weight according to EPTA-Procedure 01/2003: kg (lbs)			1.9*2/ 2.1*3 (4.2*2/ 4.6*3)

\*2 with battery BL1815

\*3 with battery BL1830

### ► Standard equipment

Safety goggles ..... 1  
Nose adapter ..... 1  
Hex wrench 3 ..... 1  
Belt clip ..... 1

**Note:** The standard equipment for the tool shown above may vary by country.

### ► Optional accessories

Pin nails; 18mm (11/16"), 25mm (1"), 30mm (1-3/16"), 35mm (1-3/8")  
Fast Charger DC18RA  
Li-ion Battery BL1815  
Li-ion Battery BL1830

► **Repair**

**CAUTION:** Repair the machine in accordance with “Instruction manual” or “Safety instructions”.

**[1] NECESSARY REPAIRING TOOLS**

Code No.	Description	Use for
783201-2	Hex. wrench 3 (standard equipment)	screwing / unscrewing Hex socket head bolt and M3x4 Pan head screw
1R220	Ratchet head 9.5	
1R222	Socket adapter	
1R228	1/4" Hex. shank bit for M4	
1R254	Torque wrench shaft 2-6N.m	
134873-0	Bit adapter	
1R266	Spring pin extractor M2	disassembling magazine section
1R268	Spring pin extractor M3	

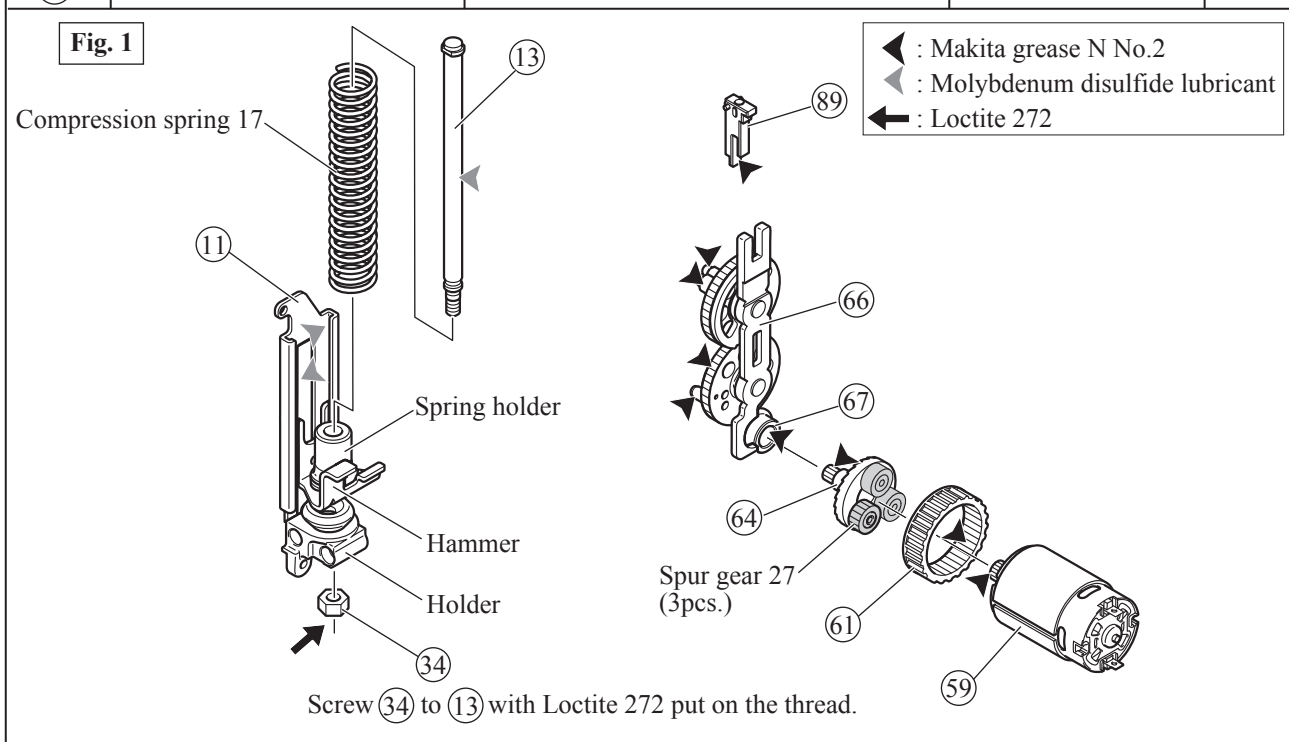
**[2] LUBRICANT AND ADHESIVE APPLICATION**

Apply the following lubricants to protect parts and product from unusual abrasion.

Apply the following adhesive.

LUBRICANT				
Item No.	Description	Portion to lubricate	Lubricant	Amount
⑪	Rail	Grooves of both sides where Hammer slides	Molybdenum disulfide lubricant	a little
⑬	Guide bolt	Shaft surface except thread portion		
⑤⑨	DC motor	Pinion gear	Makita grease N No.2	
⑥①	Internal gear 69	Teeth that engages with Spur gear 27		
⑥④	Spur gear 7 complete	Teeth that engages with the lower gear of ⑥⑥ Spur gear 55 complete		
⑥⑥	Spur gear 55 complete	Teeth Pin and cam portions		
⑥⑦	Plane bearing 10	Inside surface that contacts ⑥④ Spur gear 7 complete		
⑧⑨	Cam block	Portion that contacts ⑥⑥ Spur gear 55 complete		

ADHESIVE				
Item No.	Description	Portion to apply adhesive	Adhesive	Amount
③④	M6 Hex nut	Thread	Loctite 272	a little



## ► Repair

### [3] DISASSEMBLY/ASSEMBLY

#### [3] -1. Replacing Driver

- (1) Remove four Bind PT3x16 Tapping screws and Front cover. (Fig. 2)
- (2) Remove Upper plate as drawn in Fig. 3.
- (3) Remove Pin 4 for connecting Driver and Hammer. (Fig. 4)
- (4) Remove Driver as drawn in Fig. 5.

Fig. 2

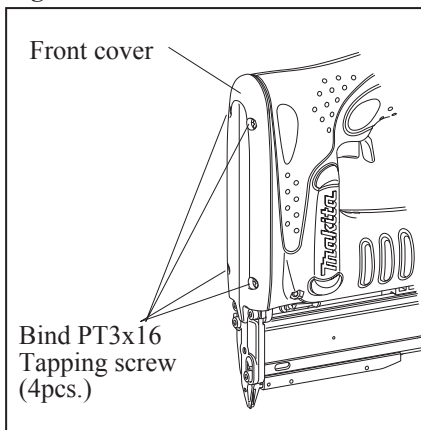


Fig. 3

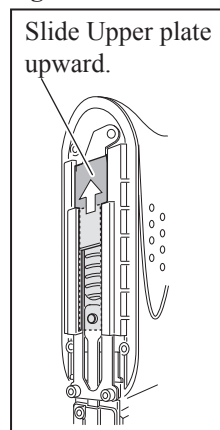


Fig. 4

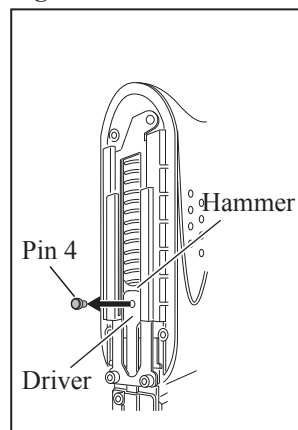
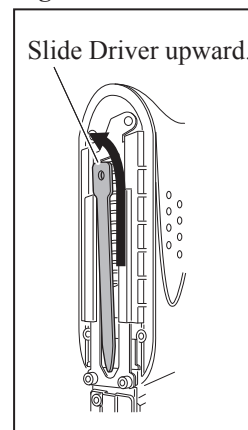


Fig. 5



**Note: A few of pin nails often remain in the tool, and if so, it is impossible to insert Driver into Driver guide.**

- (5) Remove two M4x6 Hex socket head bolts and Driver guide cover. Remove the jammed pin nails. (Fig. 6)
- (6) Slide the new Driver into the groove of Driver guide. (Fig. 7)

**Note: If M4x10 Hex socket head bolt(s) are loosened, the stroke of Driver guide may tilt.**

**In that case, slide Driver into the groove of Driver guide before securing M4x10 Hex socket head bolt(s), and then secure M4x10 Hex socket head bolt(s).**

- (7) Insert Pin 4 for connecting Driver and Hammer.
- (8) Set Driver guide cover in place with two M4x6 Hex socket head bolts.
- (9) Slide the side ends of Upper plate into the guides of Housing set. (Fig. 8)
- (10) Assemble Front cover to Housing set with four Bind PT3x16 Tapping screws.

Fig. 6

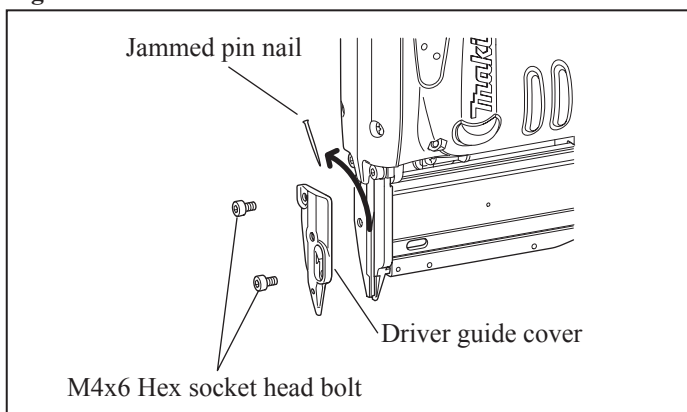


Fig. 7

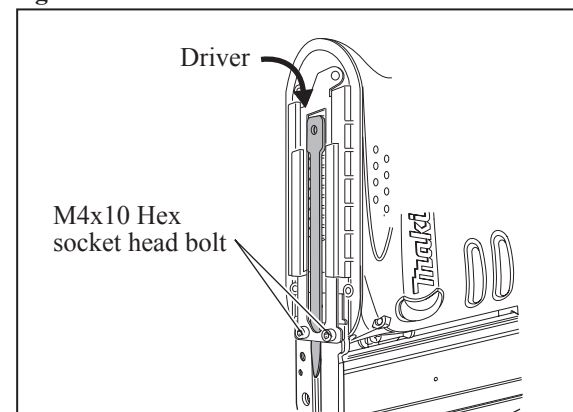
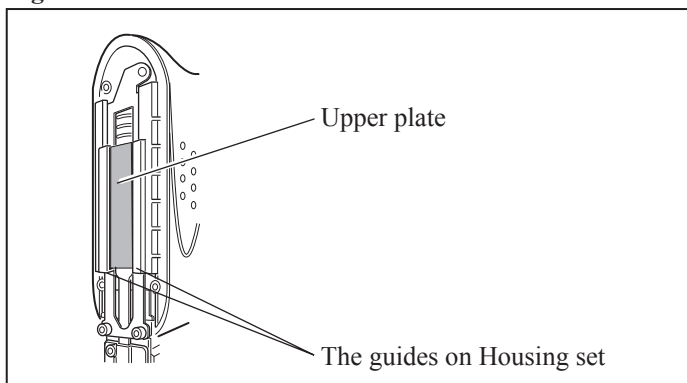


Fig. 8



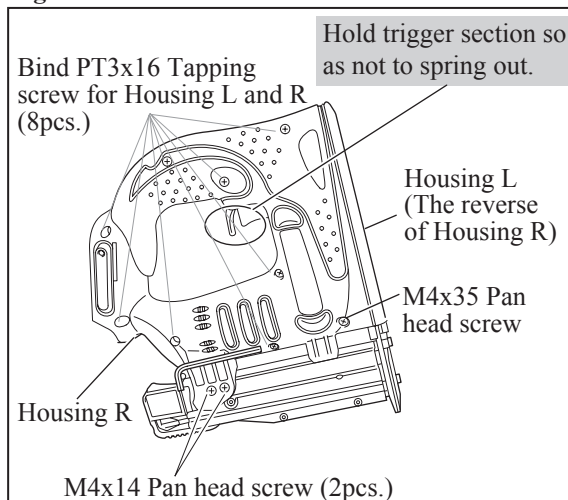
## ► Repair

### [3] DISASSEMBLY/ASSEMBLY

#### [3] -2. Replacing Switch, LED circuit and Terminal

- (1) Do the steps (1), (2), (3) and (4) of the previous page.
- (2) Insert Battery and pull the trigger to locate Hammer at lowest position to release tension of Compression spring 17. Remove Battery after this procedure is finished. Go to the next step without changing spring position in case Switch or DC motor is disorder.
- (3) Separate housing R by removing Tapping screws and Pan head screws drawn in **Fig. 9** while holding trigger section to prevent spring from jumping out.
- (4) Switch, LED circuit and Terminal now can be removed.

Fig. 9



#### [3] -3. Replacing Motor

- (1) Remove Front cover and Housing R as drawn in **Fig. 2** and **Fig. 9**.
  - (2) Remove M4x6 Hex socket head bolt. Pull out Upper rail complete, and then separate Magazine ass'y from Housing L by removing two M4x10 Hex socket head bolts. (**Fig. 10**)
  - (3) Dismantle Housing R by removing 8 pcs. of Bind PT3x16 Tapping screws, 2 psc of M4x14 Pan head screw and a M4x35 PAN head screw. Now DC motor can be removed provided Compression spring 17 has no tension.
  - (4) When Motor or Switch is out of order, Hammer of Spring section often stops in the halfway position and Compression spring 17 remains compressed. It is impossible to remove DC motor from Housing L. In this condition, remove 2pcs. of Bin PT3x16 Tapping screw (**Fig.11**), and insert slotted screwdriver into the gap between Housing L and Rail of Spring section, and then lever up Spring section with the slotted screwdriver as drawn in **Fig. 12**.
- Note • Cover Spring section with cloth in order not to pinch your finger.**  
**• Hold Spring section by hand to prevent Compression spring 17 from jumping out.**
- (5) Remove Motor from Housing L.

Fig. 10

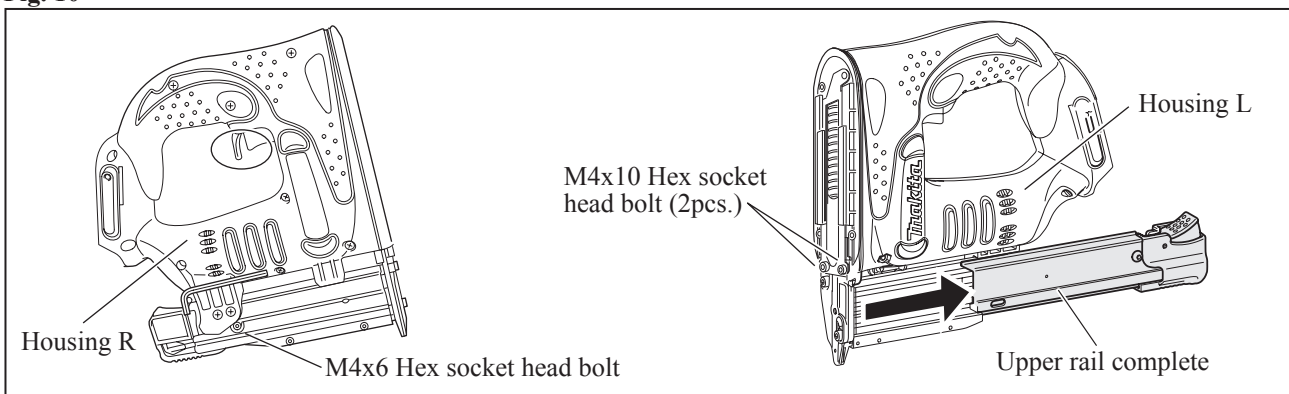


Fig. 11

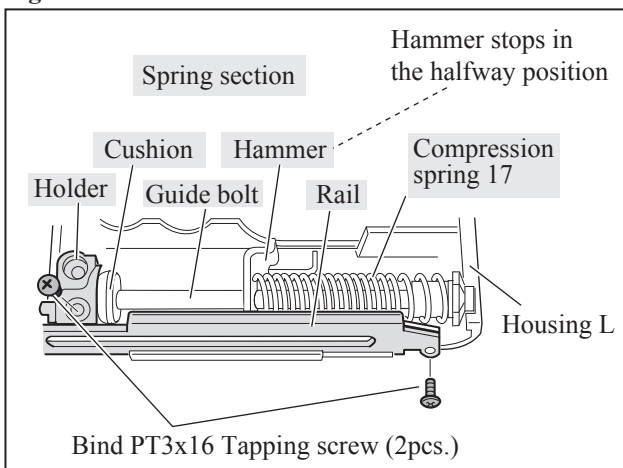
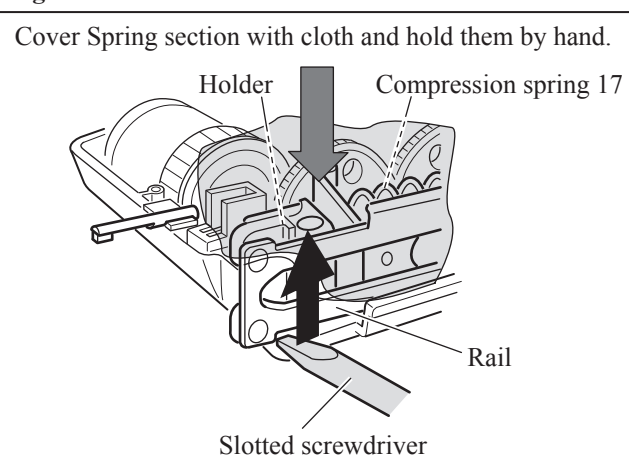


Fig. 12



► **Repair**

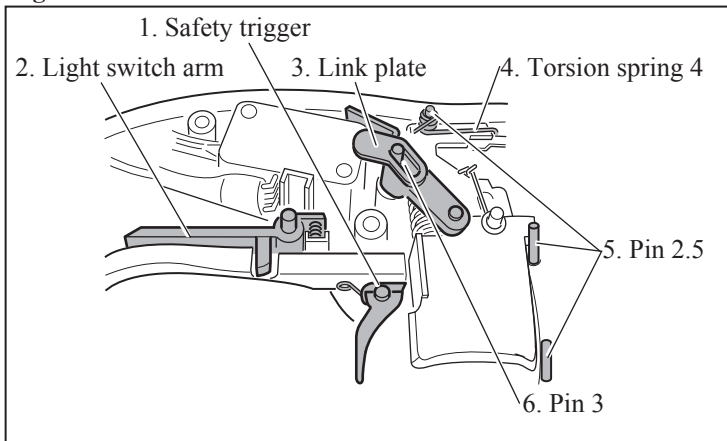
**[3] DISASSEMBLY/ASSEMBLY**

**[3] -4. Trigger Section**

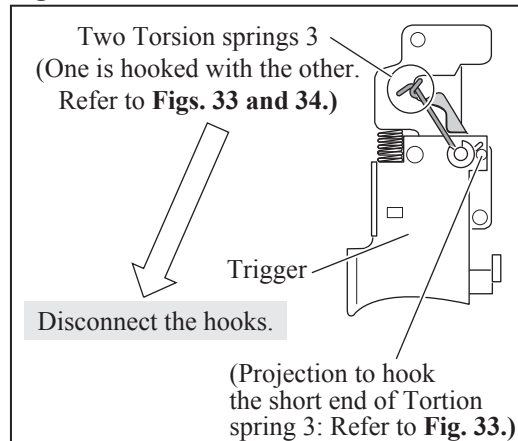
**DISASSEMBLING**

- (1) Remove Front cover and Housing R. (Fig. 2 and Fig. 9)
- (2) Remove the parts around trigger section in the following order. (Fig. 13)
  1. Safety trigger 2. Light switch arm 3. Link plate 4. Torsion spring 4 5. Pin 2.5 (3pcs.) 6. Pin 3
- (3) Disassemble guide plate in order of Figs. 14, 15 and 16.

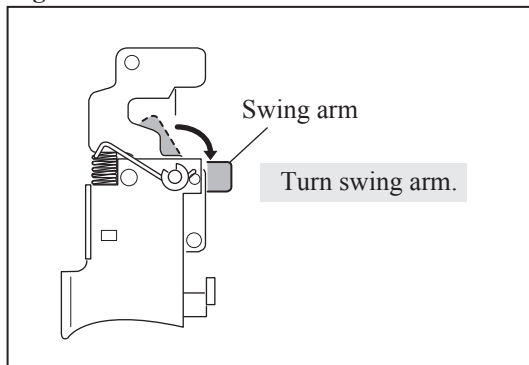
**Fig. 13**



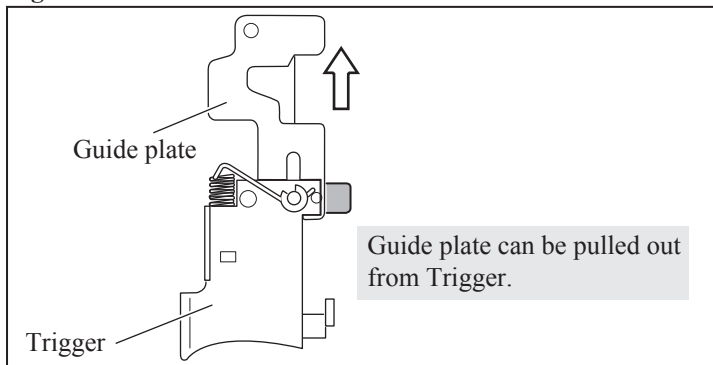
**Fig. 14**



**Fig. 15**



**Fig. 16**

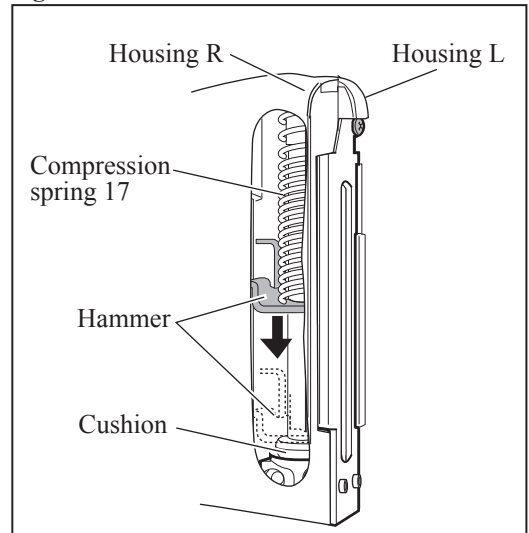


**[3] -5. Spring Section**

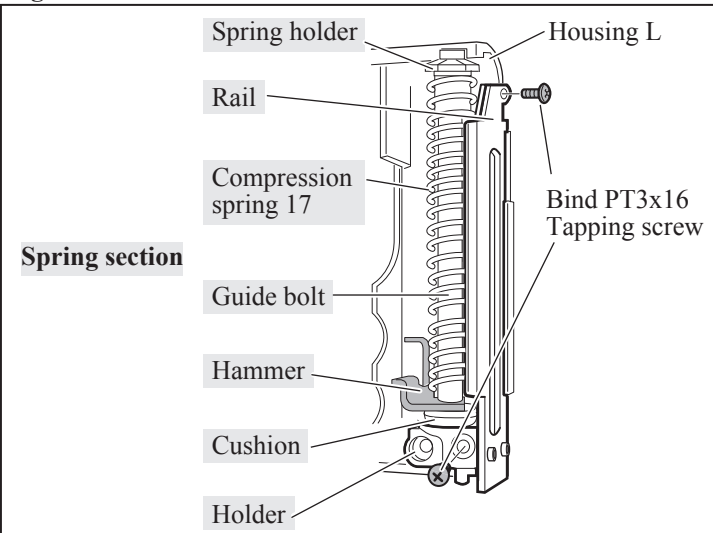
**DISASSEMBLING**

- (1) Install Battery BL1430. Slide Sliding door section of Magazine to make anti-fire mechanism invalid. Pull Trigger in a blink and release it until Hammer reaches the lowest position. (Fig. 17)
- Note: Be sure to remove Battery BL1430 after the above step.**
- (2) After removing Housing R and Front cover, separate Spring section from Housing L by removing Two Bind PT3x16 Tapping screws. (Fig. 18)

**Fig. 17**



**Fig. 18**



► **Repair**

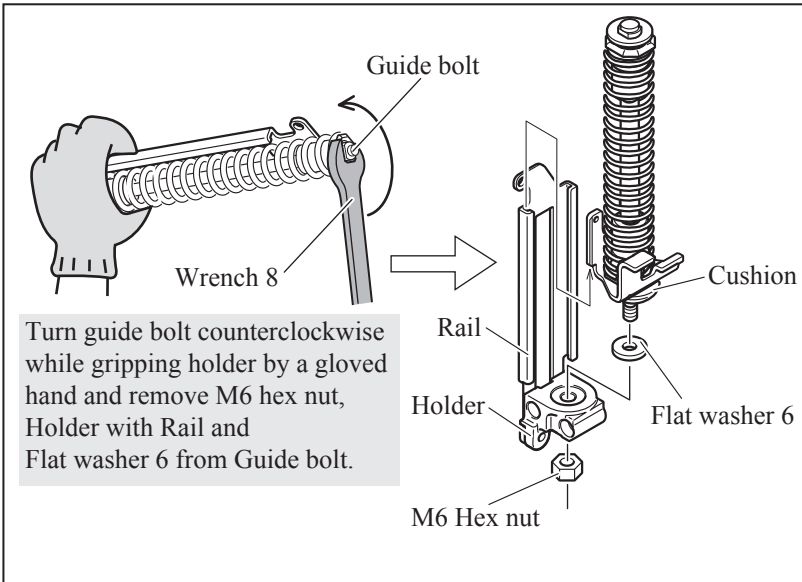
**[3] DISASSEMBLY/ASSEMBLY**

**[3] -5. Spring Section (cont.)**

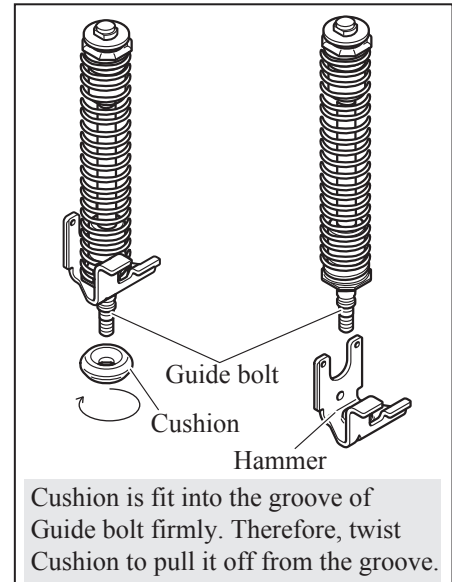
DISASSEMBLING

(3) Disassemble the Spring section in order of **Fig. 19, 22**. Spring section is removed as drawn in **Fig. 23**.

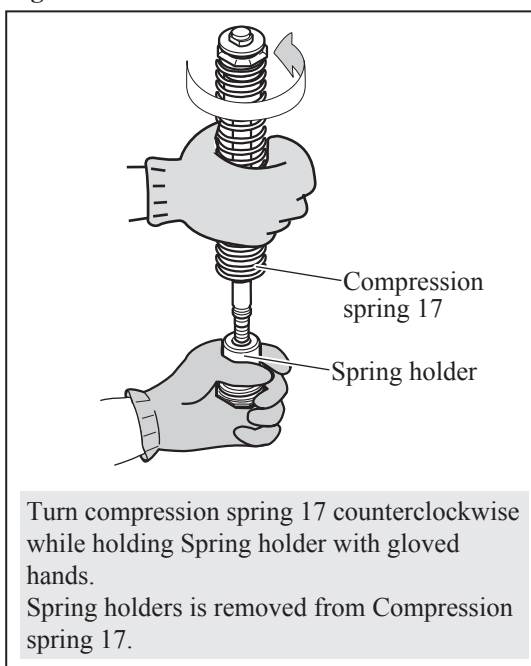
**Fig. 19**



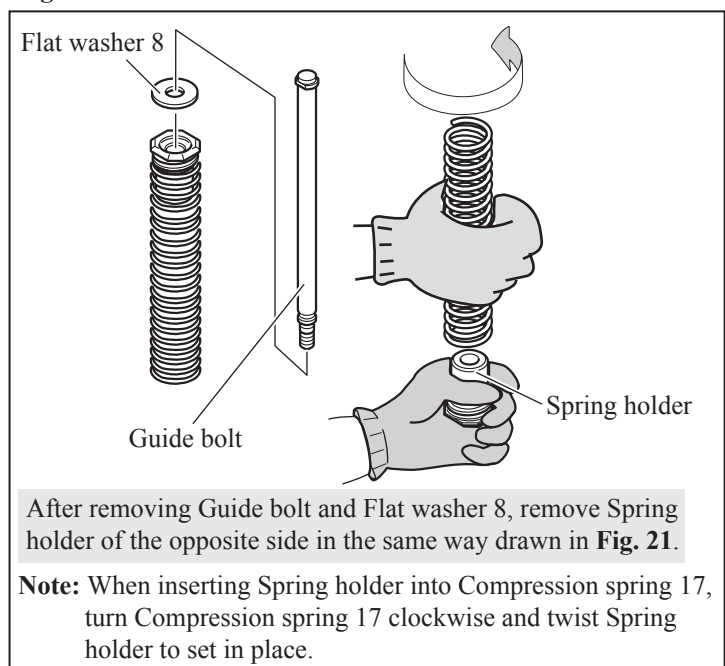
**Fig. 20**



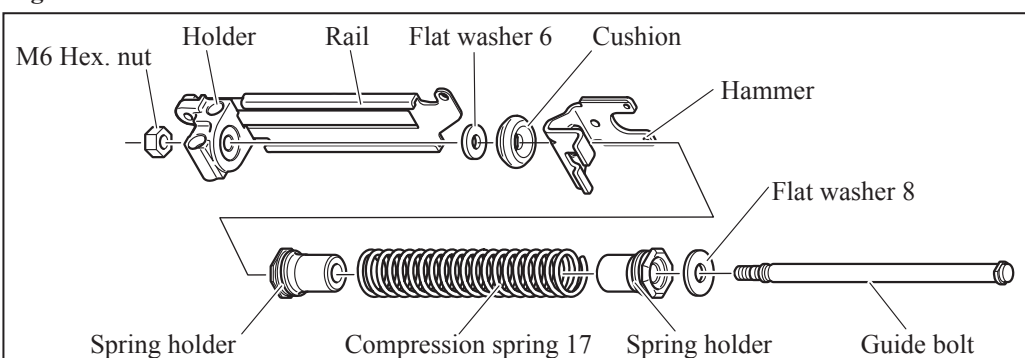
**Fig. 21**



**Fig. 22**



**Fig. 23**



## ► Repair

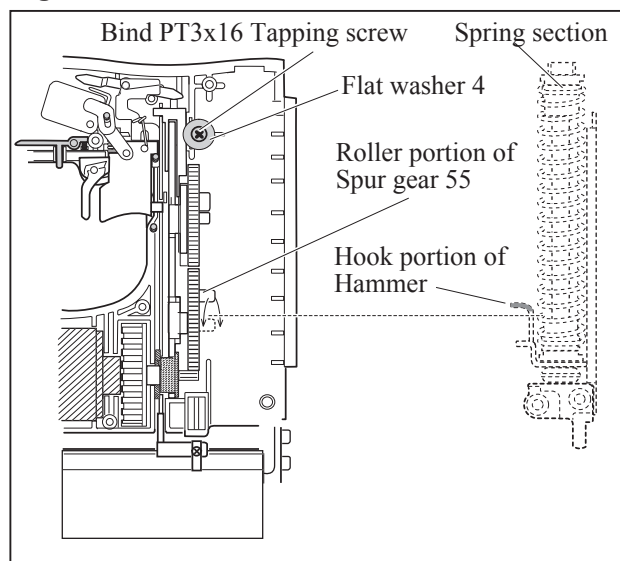
### [3] DISASSEMBLY/ASSEMBLY

#### [3] -6. Spring section (cont.)

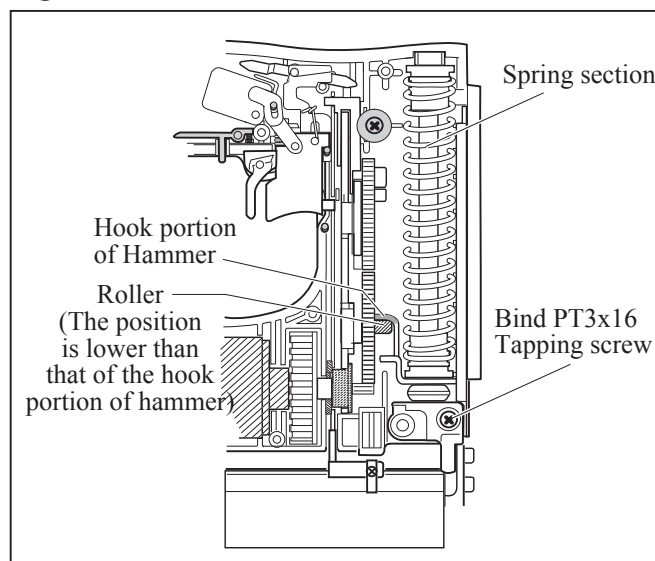
##### ASSEMBLING

- (1) Take the reverse steps of the disassembling procedure for Spring section.
- (2) Fix Spur gear 55 complete with Flat washer 4 and Bind PT3x16 Tapping screw.  
Install Spring section in Housing L while adjusting Roller position of Spur gear 55 complete to under the hook portion of hammer (**Fig. 24**).
- (3) Fix Spring section with Bind PT3x16 Tapping screw and mount driver guide, driver, and driver guide cover to Housing R. (**Fig. 25**)

**Fig. 24**



**Fig. 25**



► **Repair**

**[3] DISASSEMBLY/ASSEMBLY**

**[3] -5. Motor and Gear Section**

**ASSEMBLING**

(1) Assemble Cam block section to Spur gear 55 complete. (**Fig. 26**) Usually, there is no need to disassemble Cam block section for repair.

**Note: Put Makita grease N No.2 to the inner and the outer surface of Internal gear 69, the pins of Spur gear 7 complete and the teeth of Spur gear 55 complete.**

(2) Mount the following parts on Housing L (**Fig. 27**);

Spur gear 55 complete, Cam block section, Lock arm section and two Leaf springs

**Note: When disassembling Lock arm section, do not remove M3x4 Pan head screw. It becomes easy to set gear section in place.**

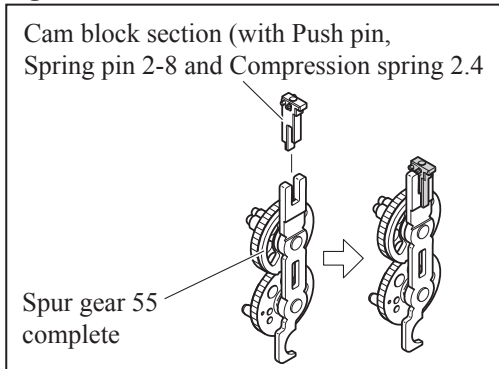
Regarding two Leaf springs, install them in the space for Internal gear 69 as drawn in **Fig. 28**.

(3) Face the rim portion of Internal gear 69 oposit side of DC motor and assemble Internal gear section (**Fig. 29**).

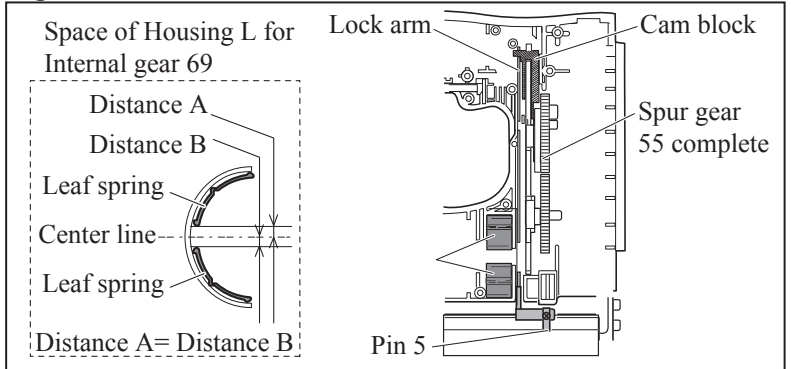
(4) Install Anti back plate to Spur gear 7 complete with the direction described in **Fig. 30**

and mount them in Housing L. (**Fig. 31**) Be sure to put Roller portion of Spur gear 55 complete under the hook of Hammer.

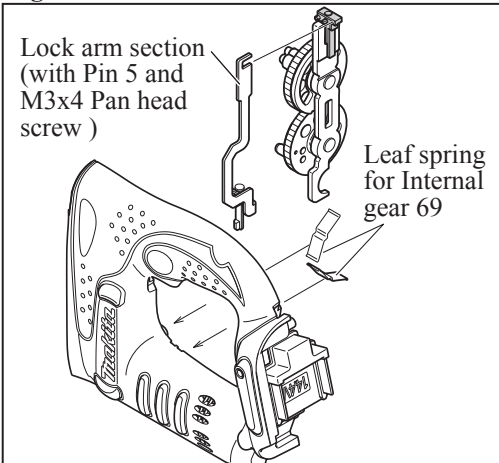
**Fig. 26**



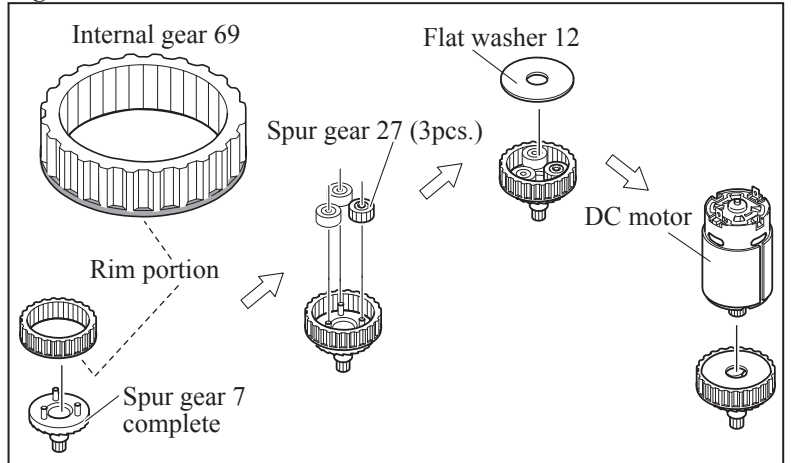
**Fig. 27**



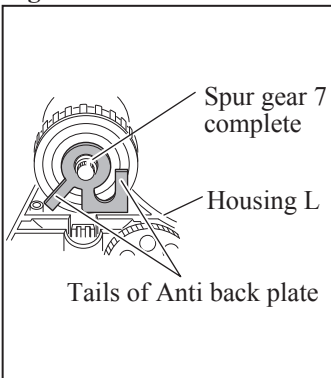
**Fig. 28**



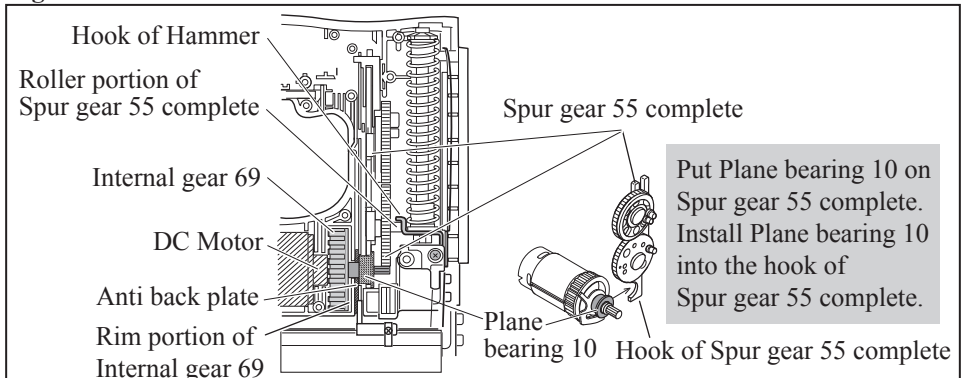
**Fig. 29**



**Fig. 30**



**Fig. 31**



**Caution: If using the tool on condition that Roller portion of Spur gear 55 complete is put on the hook of Hammer by mistake, DC motor runs without transmitting the torque to gear section.**



► **Repair**

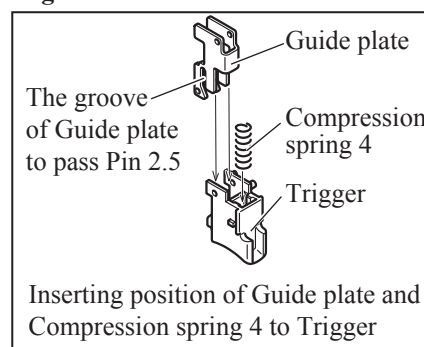
**[3] DISASSEMBLY/ASSEMBLY**

**[3] -6. Switch Mechanism**

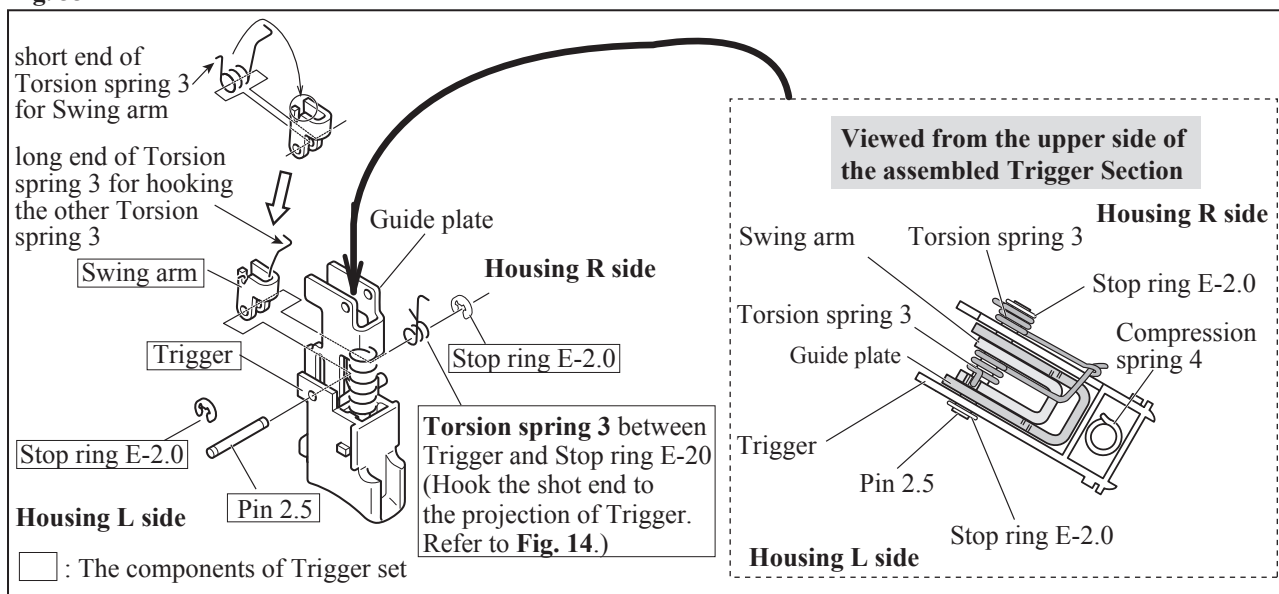
**ASSEMBLING**

- (1) Insert Guide plate and Compression spring 4 into Trigger. (**Fig. 32**)
- (2) Hook the short end of Torsion spring 3 with Swing arm, and then insert the Torsion spring 3 into Swing arm. (**Fig. 33**)
- (3) Insert Swing arm into Guide plate so that Pin 2.5 can be passed through the grooves of Guide plate in the next step. (**Figs. 32 and 33**)
- (4) Pass Pin 2.5 through the holes of Trigger and the grooves of Guide plate while setting two Torsion springs 3 as drawn in **Figs. 14 and 33** and secure Pin 2.5 with two Stop rings E-2.0.

**Fig. 32**

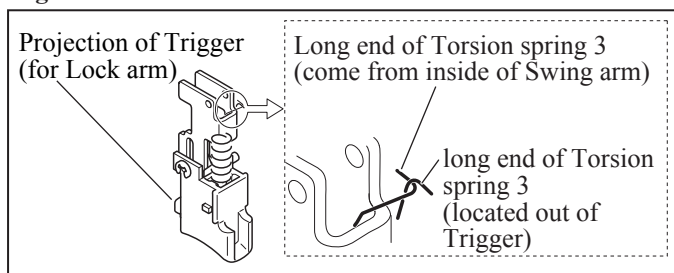


**Fig. 33**

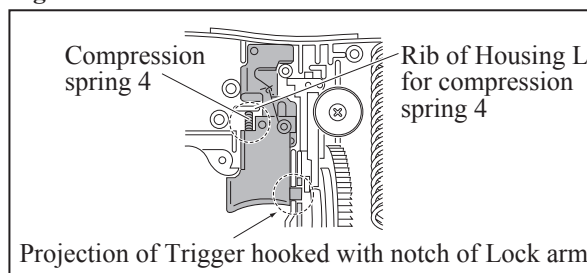


- (5) Hook one Torsion spring 3 with the other (Ref. **Fig. 33**) as drawn in **Fig. 34**.
- Note: Torsion spring 3 for Swing arm is different from Torsion spring 3 for Guide plate and Switch arm.**
- (6) Hook the projection of Trigger with the notch of Lock arm. (**Figs. 34 and 35**)
  - (7) Install Trigger section in Housing L while compressing Compression spring 4 to put it on the rib of Housing L as drawn in **Fig. 35**.
  - (8) After putting Switch arm in Guide plate, insert Pin 2.5 through the holes of Guide plate and Switch arm. Pay attention to the direction of Switch arm. Refer to **Fig. 36**.
  - (9) Install Torsion spring 4 for Guide plate and Switch arm (Ref. **Fig. 33**) as drawn in **Fig. 37**.

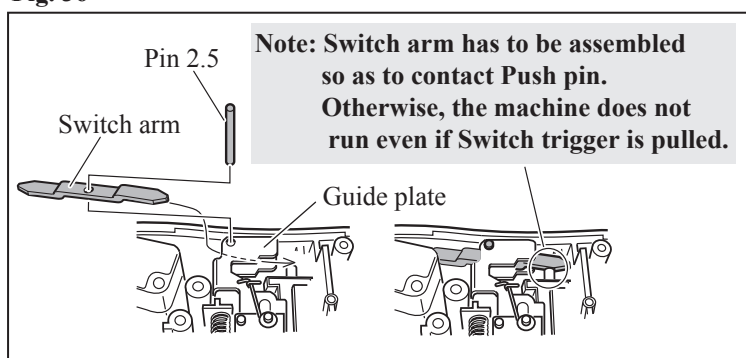
**Fig. 34**



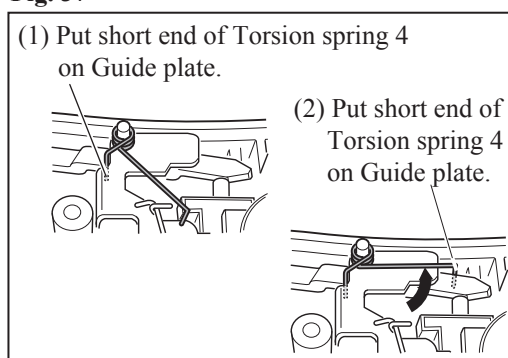
**Fig. 35**



**Fig. 36**



**Fig. 37**



► **Repair**

**[3] DISASSEMBLY/ASSEMBLY**

**[3] -6. Switch Mechanism (cont.)**

**ASSEMBLING**

- (7) Insert the remaining two Pins 2.5 firmly into Housing set L until they stop as drawn in **Fig. 38**.
- (8) Install Link plate to Housing L with Pin 3 through Link plate. (**Fig. 39**)
- (9) Insert the projection of Light switch arm into Compression spring 2 firmly. And then insert the axis of Light switch arm into hole of Housing L and push Compression spring 2 to the emboss of Housing L. (**Fig. 40**)
- (10) Set Torsion spring 4 in place. Install Safety trigger and Torsion spring 4 to Housing L with Pin 3 as drawn in **Fig. 41**.

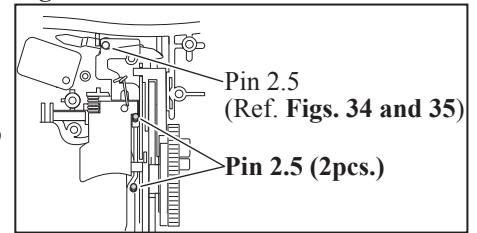
All the components are assembled as drawn in **Fig. 42**.

- (11) Fasten the two positions with two Bind PT3x16 tapping screws as drawn in **Fig. 43** before assembling Housing R to Housing L.

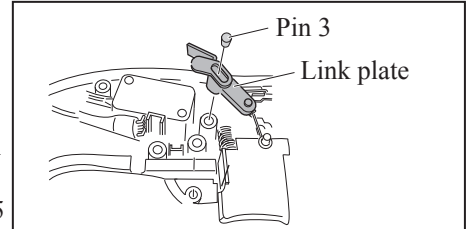
**Note:** Avoid loosening M3x4 Pan head screw that fastens Lock arm and Pin 5 as much as possible.

If loosening is unavoidable, pretighten M3x4 Pan head screw with Loctite 242 put on the thread and finish the all reassembling work. After that, check the trigger's smooth action and finally tighten the screw when the smooth action can be obtained.

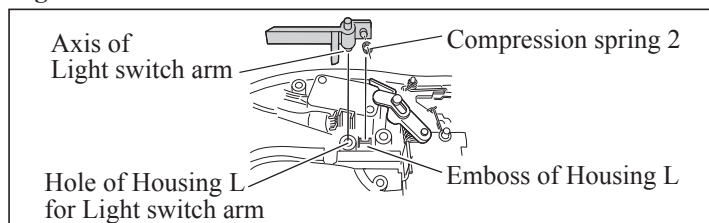
**Fig. 38**



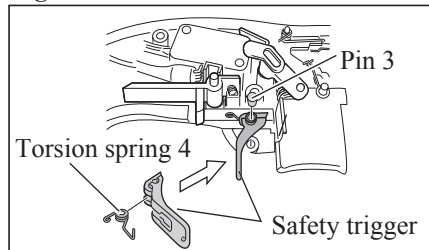
**Fig. 39**



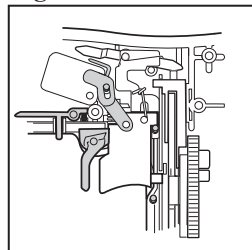
**Fig. 40**



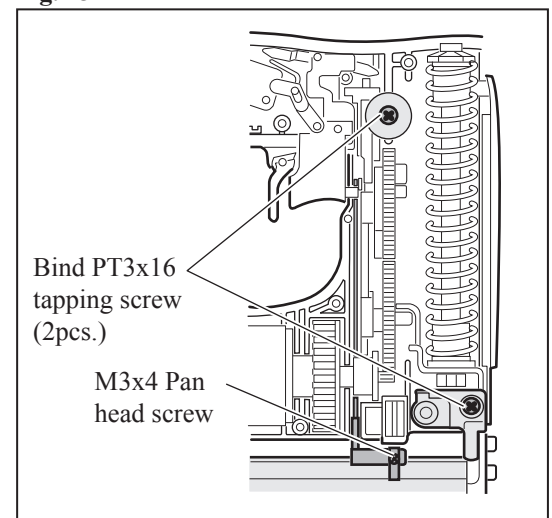
**Fig. 41**



**Fig. 42**



**Fig. 43**



► **Repair**

**[3] DISASSEMBLY/ASSEMBLY**

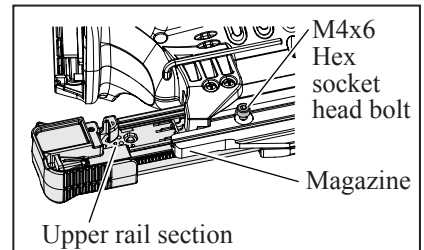
**[3] -7. Magazine**

**DISASSEMBLING**

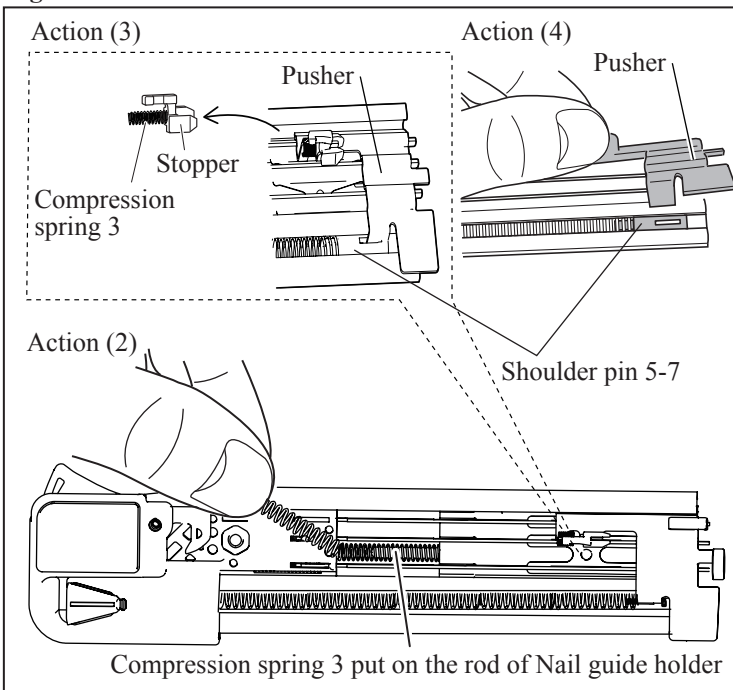
- (1) Loosen M4x6 Hex socket head bolt three turns, then pull out Upper rail section from Magazine . (Fig. 44)
- (2) Remove large Compression spring 3 that is put on Nail guide holder. (Fig. 45)
- (3) Remove Stopper with small Compression spring 3 from Pusher. (Fig. 45)
- (4) Pusher is just inserted into the slit of Shoulder pin 5-7. Therefore, Pull Pusher out straight from the slit side of Shoulder pin 5-7. (Fig. 45)
- (5) Loosen M4x10 Pan head screw three turns so that Upper rail section has a clearance to push down three Nail stoppers and remove their hooks from Nail guide holder in the next step.

**Note: Do not remove the screw. This is because the complete removing will cause the removal of Slide door cap and all the small Springs in the magazine section.**

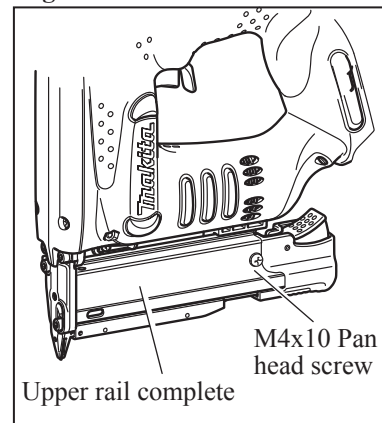
**Fig. 44**



**Fig. 45**



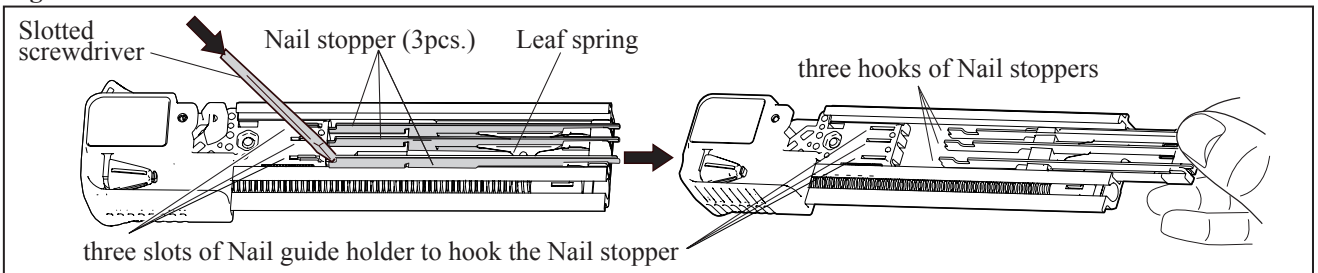
**Fig. 46**



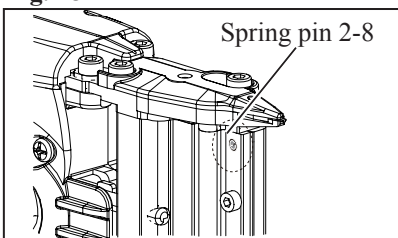
- (6) Remove three Nail stoppers in order. Push each Nail stopper with Slotted screwdriver to remove the hook from the slot of each Nail stopper. (Fig. 47)  
Nail guide holder is removed.

- (7) Use 1R266 to remove Spring pin 2-8. (Fig. 48) Use 1R267 to remove Spring pins 3-10 and 3-18. (Fig. 49)

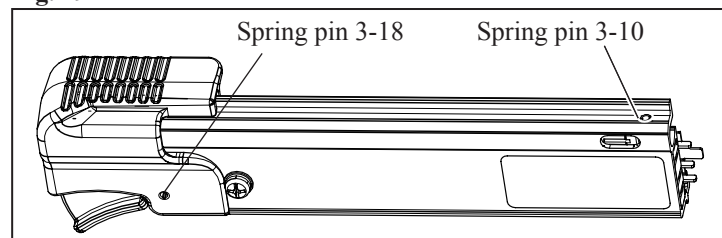
**Fig. 47**



**Fig. 48**



**Fig. 49**



► **Repair**

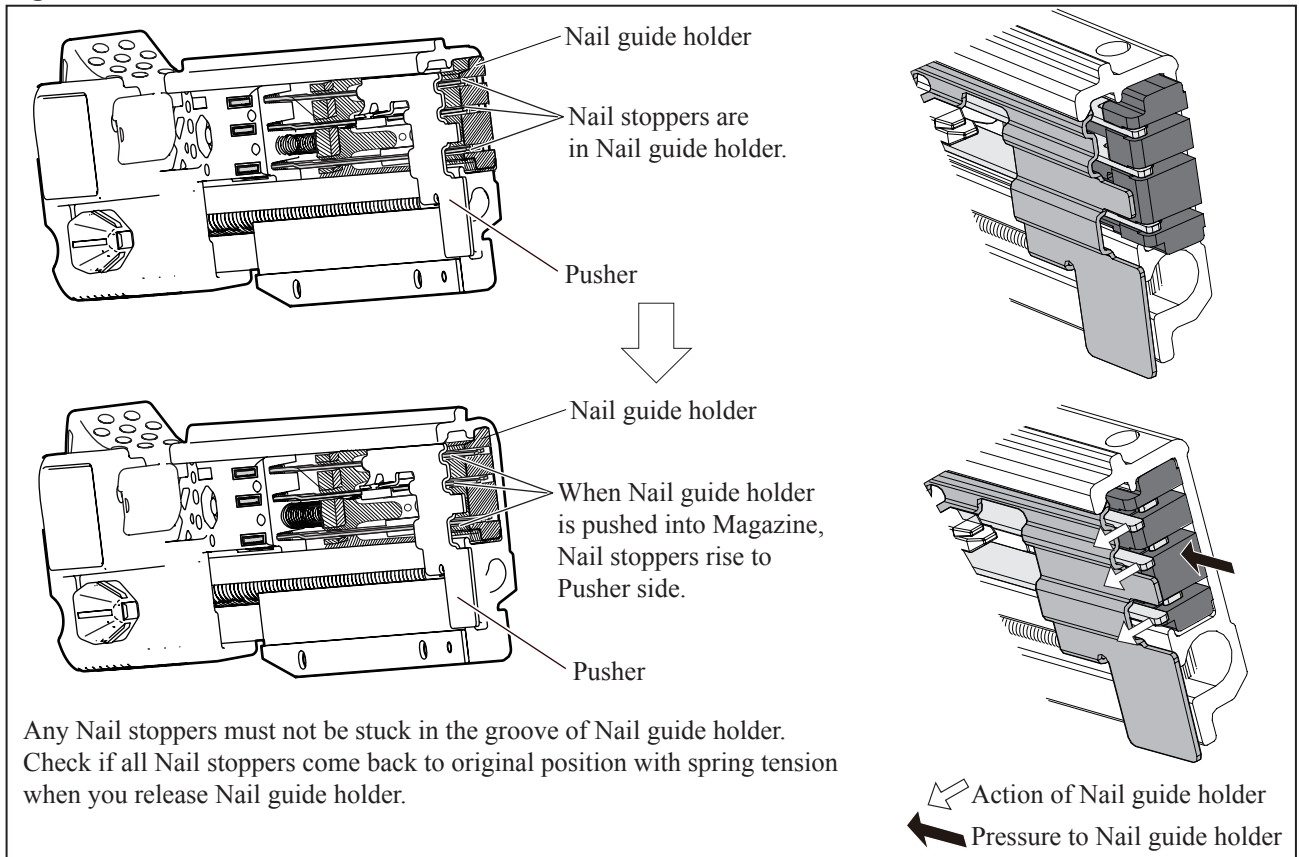
**[3] DISASSEMBLY/ASSEMBLY**

**[3] -7. Magazine (cont.)**

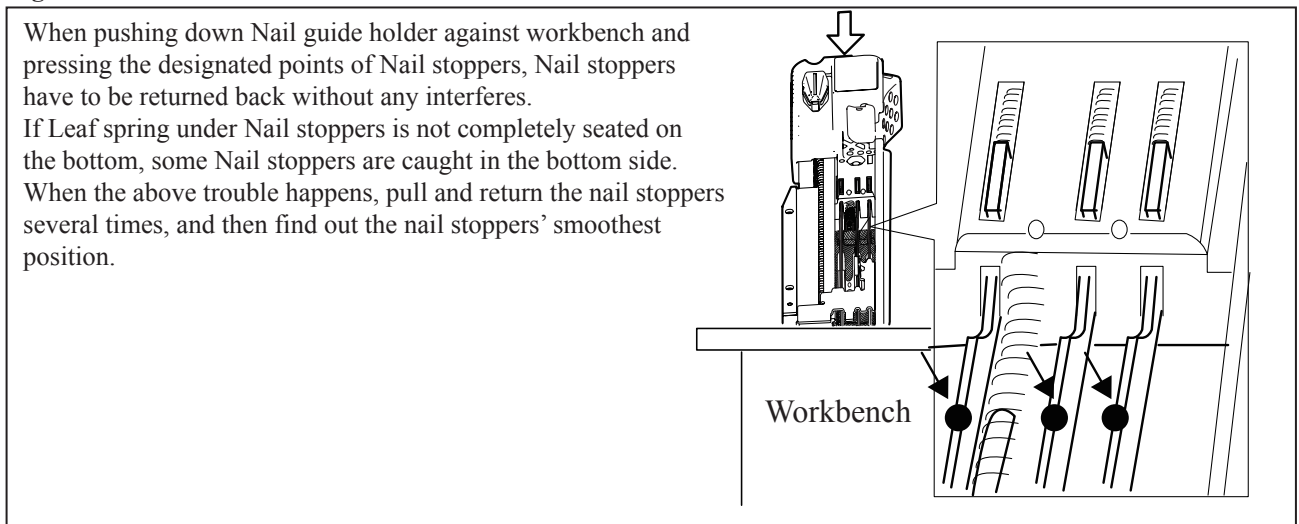
Points of ASSEMBLING

- Be sure to check that Nail stoppers work properly as drawn in **Figs. 50 and 51**.

**Fig. 50**

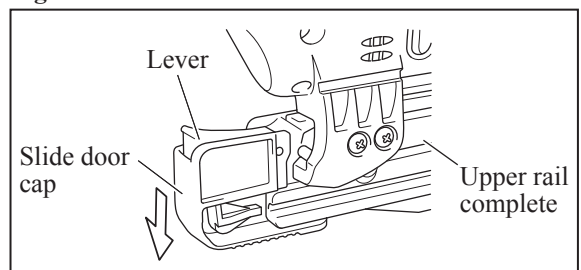


**Fig. 51**



- When installing Slide door cap into Upper rail complete, press Slide door cap fully in the direction of an arrow drawn in **Fig. 52** and tighten M4x10 Pan head screw at the same time.
- While facing the slot of Shoulder pin 5-7 to the magazine side as drawn in **Fig. 45**, install Pusher to Upper rail complete.

**Fig. 52**



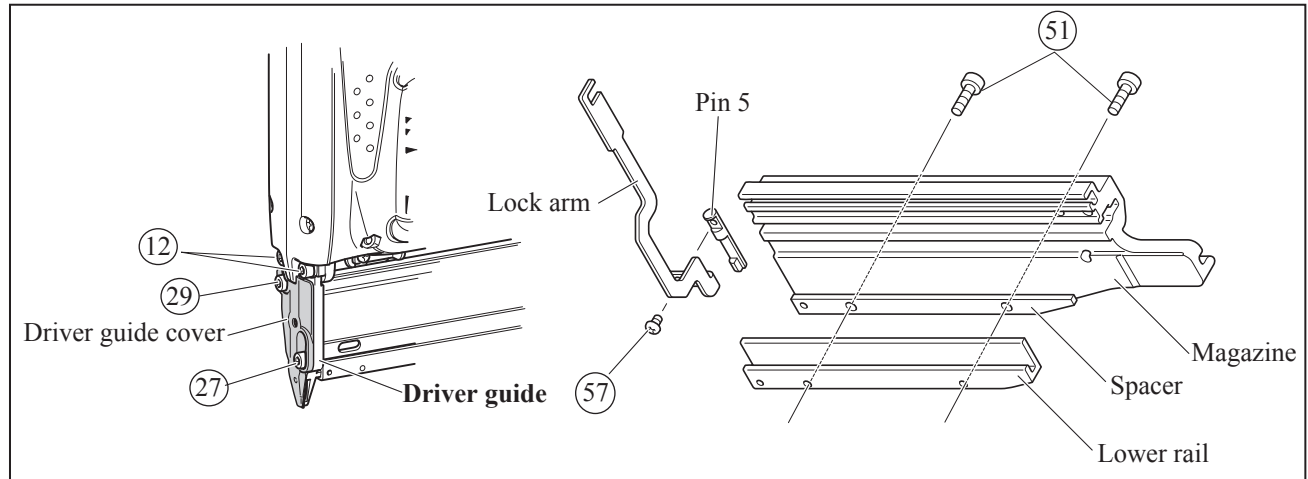
► **Repair**

**[3] DISASSEMBLY/ASSEMBLY**

**[3] -8. Fastening Torque**

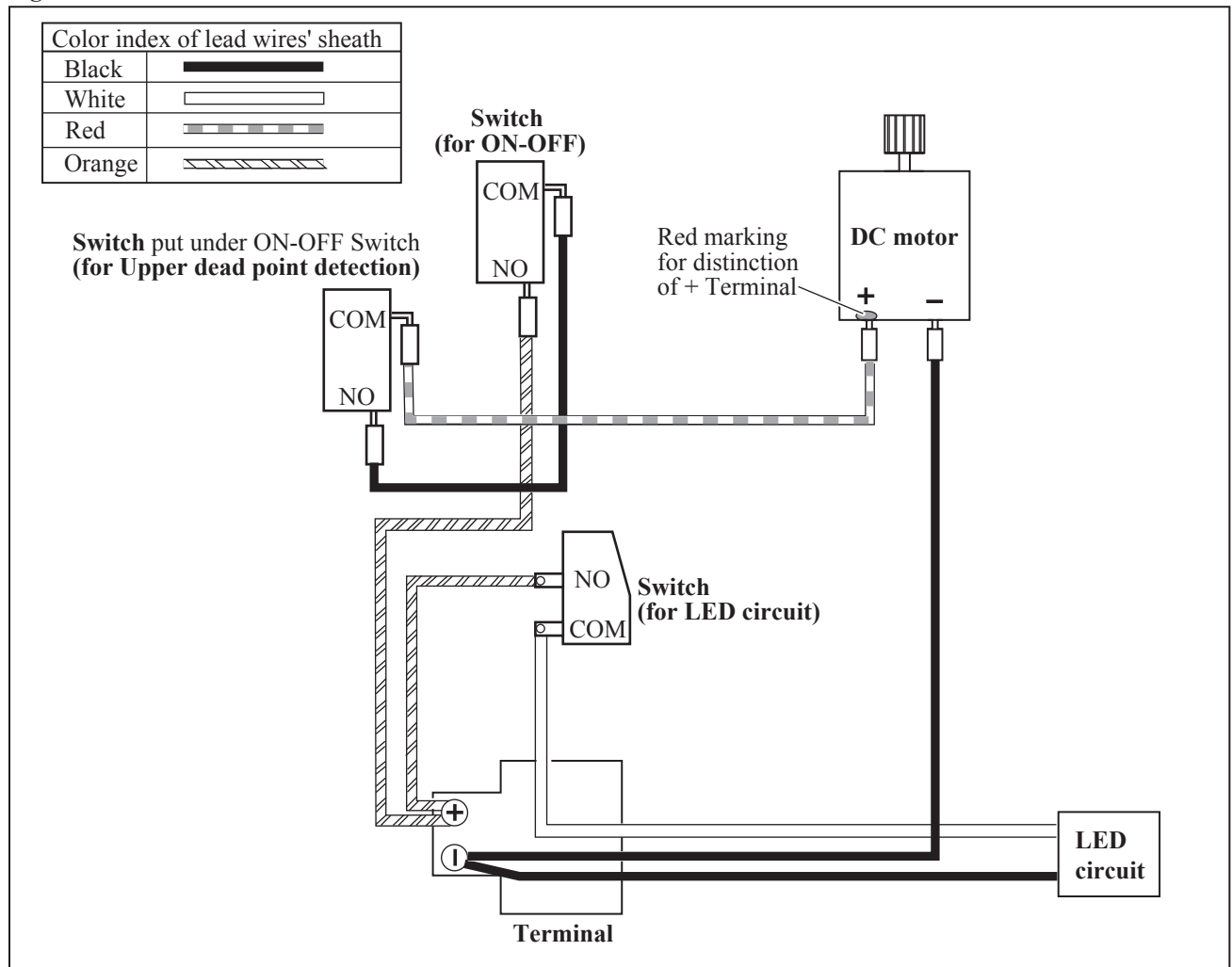
Item No.	Description	Fastening Torque
(29)	M4x14 Hex socket head bolt for assembling Driver guide and Magazine	2.5 N.m
(27)	M4x6 Hex socket head bolt for assembling Driver guide and Driver guide cover	4.0 N.m
(12)	M4x10 Hex socket head bolt for assembling Driver guide and Holder	4.0 N.m
(51)	Hex socket head bolt M3x10 for assembling Magazine and Lower rail	1.0 N.m
(57)	Pan head screw M3x4 for assembling Pin 5 and Lock arm	1.0 N.m

**Fig. 53**



► **Circuit diagram**

**Fig. D-1**



► **Wiring diagram**

Fig. D-2

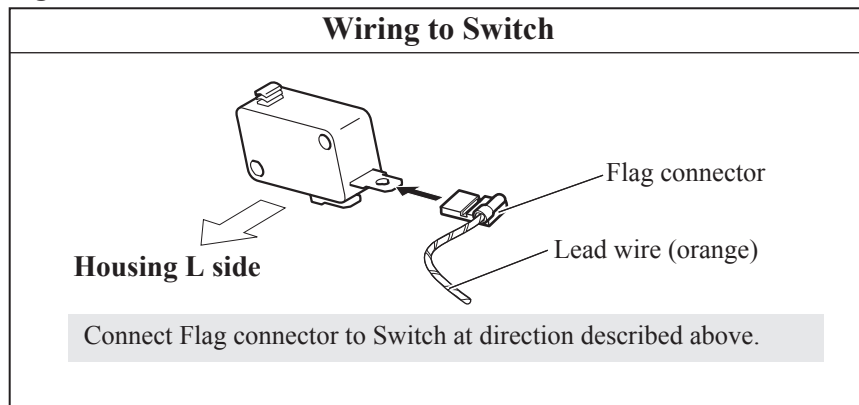


Fig. D-3

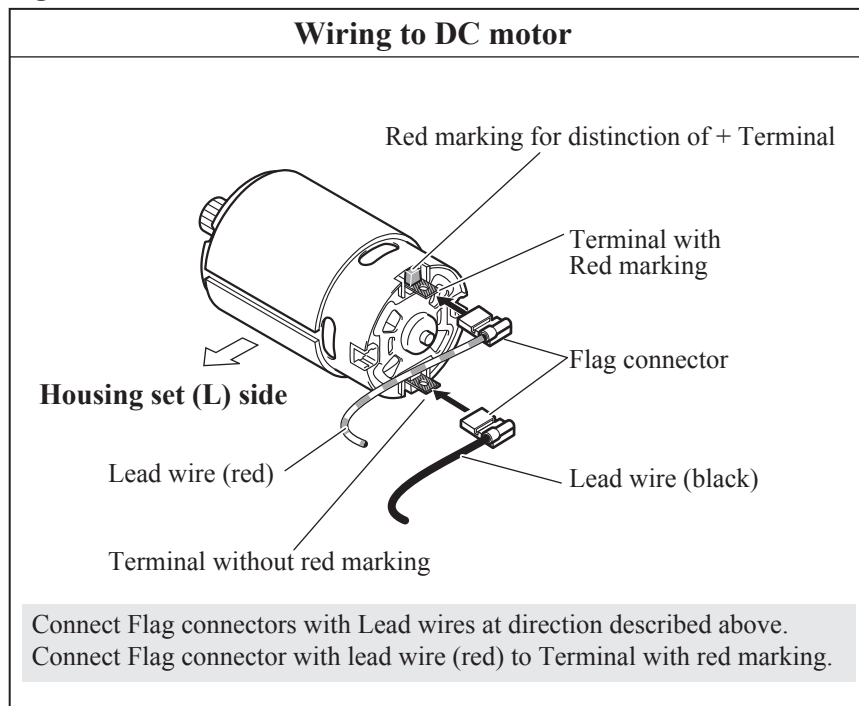
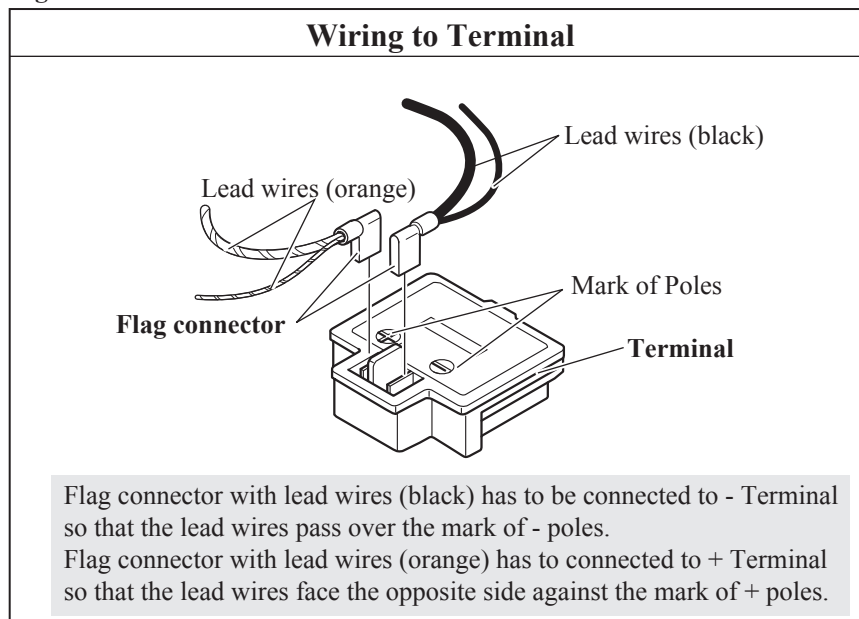
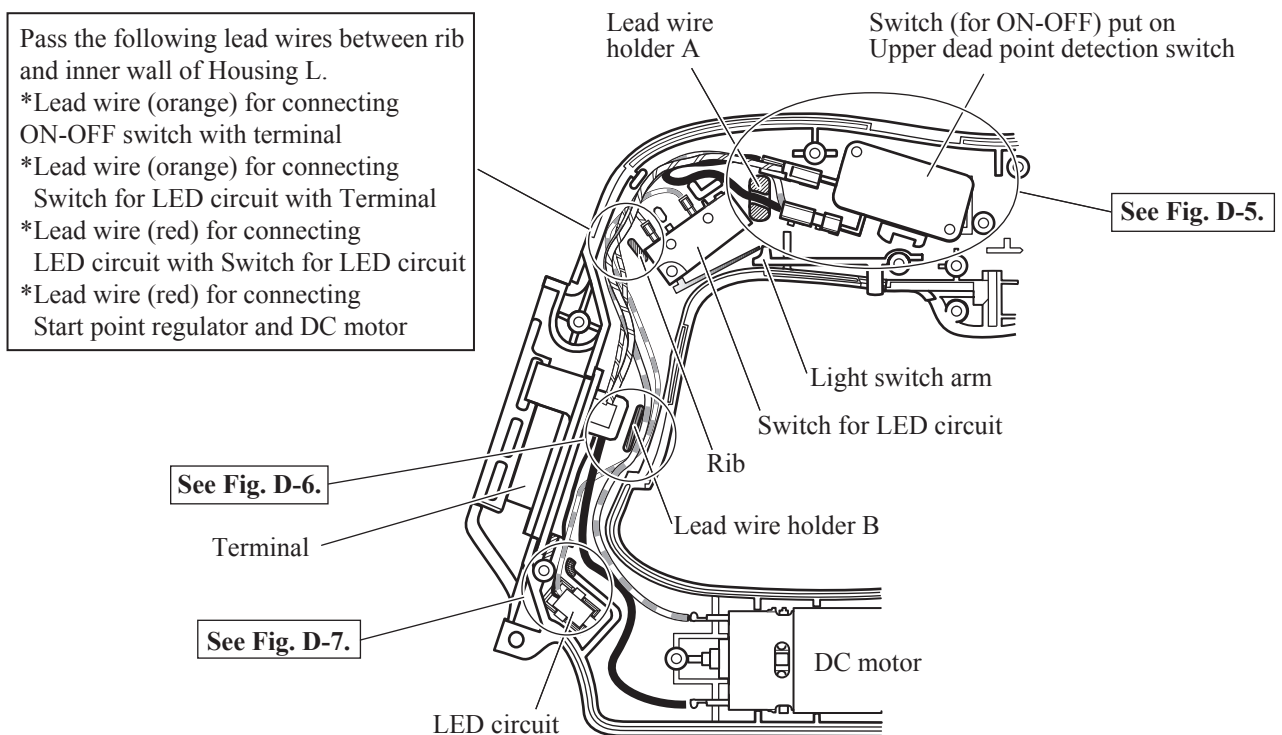
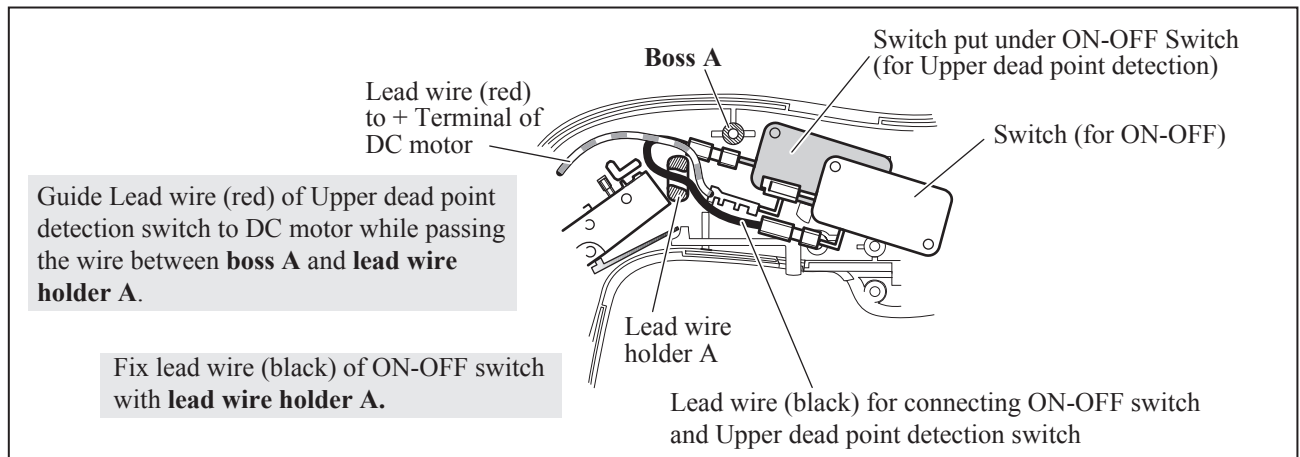


Fig. D-4

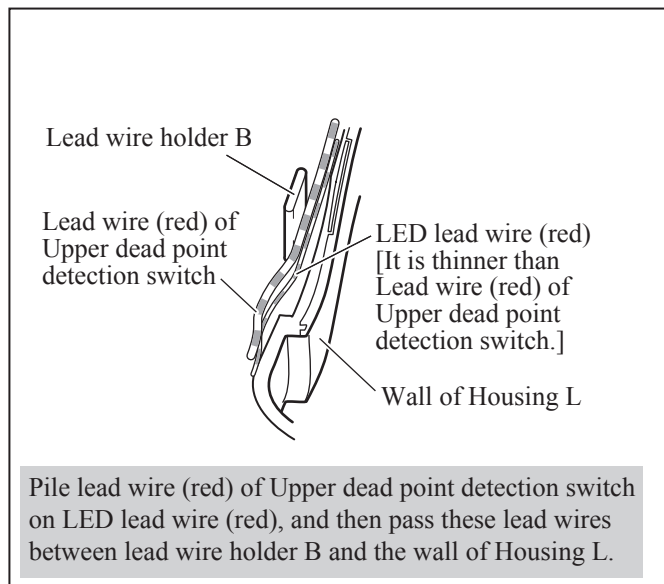


► **Wiring diagram**

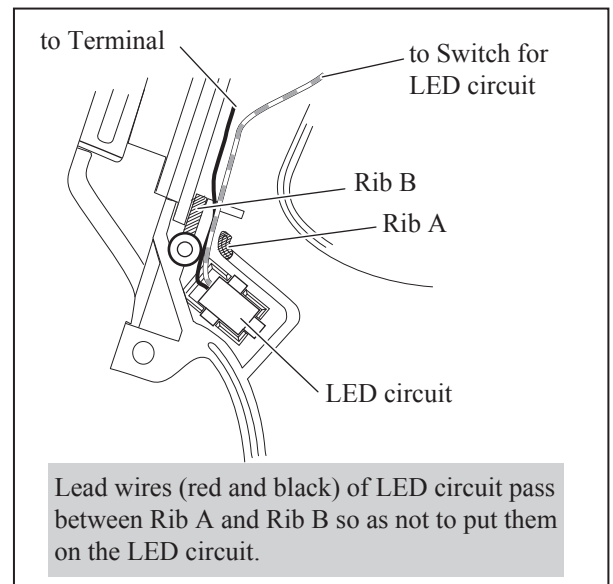
**Fig. D-5**



**Fig. D-6**



**Fig. D-7**



## Free Manuals Download Website

<http://myh66.com>

<http://usermanuals.us>

<http://www.somanuals.com>

<http://www.4manuals.cc>

<http://www.manual-lib.com>

<http://www.404manual.com>

<http://www.luxmanual.com>

<http://aubethermostatmanual.com>

Golf course search by state

<http://golfingnear.com>

Email search by domain

<http://emailbydomain.com>

Auto manuals search

<http://auto.somanuals.com>

TV manuals search

<http://tv.somanuals.com>