



Makita

Rotary Hammer

50 mm (2") MODEL HR5000

アメリカ

INSTRUCTION MANUAL

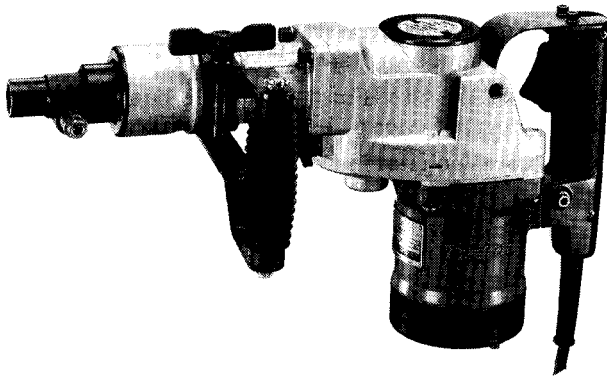

SPECIFICATIONS

Tungsten-carbide bit	Capacities		No load speed (RPM)	Blows per minute	Overall length	Net weight
	Core bit					
	Concrete	Hume pipe				
50 mm (2")	150 mm (5-7/8")	255 mm (10")	260	2,100	476 mm (18-3/4")	9.6 kg (21.1 lbs)

- Manufacturer reserves the right to change specifications without notice.
- * Note: Specifications may differ from country to country.

IMPORTANT SAFETY INSTRUCTIONS

(For All Tools)

WARNING: WHEN USING ELECTRIC TOOLS, BASIC SAFETY PRECAUTIONS SHOULD ALWAYS BE FOLLOWED TO REDUCE THE RISK OF FIRE, ELECTRIC SHOCK, AND PERSONAL INJURY, INCLUDING THE FOLLOWING:

READ ALL INSTRUCTIONS.

1. **KEEP WORK AREA CLEAN.** Cluttered areas and benches invite injuries.
2. **CONSIDER WORK AREA ENVIRONMENT.** Don't use power tools in damp or wet locations. Keep work area well lit. Don't expose power tools to rain. *Don't use tool in presence of flammable liquids or gases.*
3. **KEEP CHILDREN AWAY.** All visitors should be kept away from work area. Don't let visitors contact tool or extension cord.
4. **STORE IDLE TOOLS.** When not in use, tools should be stored in dry, and high or locked-up place — out of reach of children.
5. **DON'T FORCE TOOL.** It will do the job better and safer at the rate for which it was intended.
6. **USE RIGHT TOOL.** Don't force small tool or attachment to do the job of a heavy-duty tool. Don't use tool for purpose not intended.
7. **DRESS PROPERLY.** Don't wear loose clothing or jewelry. They can be caught in moving parts. Rubber gloves and non-skid footwear are recommended when working outdoors. Wear protective hair covering to contain long hair.
8. **USE SAFETY GLASSES.** Also use face or dust mask if cutting operation is dusty.
9. **DON'T ABUSE CORD.** Never carry tool by cord or yank it to disconnect from receptacle. Keep cord from heat, oil, and sharp edges.
10. **SECURE WORK.** Use clamps or a vise to hold work. It's safer than using your hand and it frees both hands to operate tool.
11. **DON'T OVERREACH.** Keep proper footing and balance at all times.
12. **MAINTAIN TOOLS WITH CARE.** Keep tools sharp and clean for better and safer performance. Follow instructions for lubricating and changing accessories. Inspect tool cords periodically and if damaged, have repaired by authorized service facility. Inspect extension cords periodically and replace if damaged. Keep handles dry, clean, and free from oil and grease.
13. **DISCONNECT TOOLS.** When not in use, before servicing, and when changing accessories, such as blades, bits, cutters.

14. **REMOVE ADJUSTING KEYS AND WRENCHES.** Form habit of checking to see that keys and adjusting wrenches are removed from tool before turning it on.
15. **AVOID UNINTENTIONAL STARTING.** Don't carry plugged-in tool with finger on switch. Be sure switch is OFF when plugging in.
16. **OUTDOOR USE EXTENSION CORDS.** When tool is used outdoors, use only extension cords intended for use outdoors and so marked.
17. **STAY ALERT.** Watch what you are doing, use common sense. Don't operate tool when you are tired.
18. **CHECK DAMAGED PARTS.** Before further use of the tool, a guard or other part that is damaged should be carefully checked to determine that it will operate properly and perform its intended function. Check for alignment of moving parts, binding of moving parts, breakage of parts, mounting, and any other conditions that may affect its operation. A guard or other part that is damaged should be properly repaired or replaced by an authorized service center unless otherwise indicated elsewhere in this instruction manual. Have defective switches replaced by authorized service center. Don't use tool if switch does not turn it on and off.
19. **GUARD AGAINST ELECTRIC SHOCK.** Prevent body contact with grounded surfaces. For example; pipes, radiators, ranges, refrigerator enclosures.
20. **REPLACEMENT PARTS.** When servicing, use only identical replacement parts.

VOLTAGE WARNING: Before connecting the tool to a power source (receptacle, outlet, etc.) be sure the voltage supplied is the same as that specified on the nameplate of the tool. A power source with voltage greater than that specified for the tool can result in **SERIOUS INJURY** to the user — as well as damage to the tool. If in doubt, **DO NOT PLUG IN THE TOOL.** Using a power source with voltage less than the nameplate rating is harmful to the motor.

ADDITIONAL SAFETY RULES

- 1. Wear a hard hat (safety helmet), safety glasses and/or face shield. It is also highly recommended that you wear a dust mask, ear protectors and thickly padded gloves.**
- 2. Be sure the bit is secured in place before operation.**
- 3. Under normal operation, the tool is designed to produce vibration. The screws can come loose easily, causing a breakdown or accident. Check tightness of screws carefully before operation.**
- 4. In cold weather or when the tool has not been used for a long time, let the tool warm up for several minutes by operating it under no load. This will loosen up the lubrication. Without proper warm-up, hammering operation is difficult.**
- 5. Always be sure you have a firm footing.
Be sure no one is below when using the tool in high locations.**
- 6. Hold the tool firmly with both hands.**
- 7. Keep hands away from moving parts.**
- 8. Do not leave the tool running. Operate the tool only when hand-held.**
- 9. Do not point the tool at any one in the area when operating. The bit could fly out and injure someone seriously.**
- 10. When drilling or chipping into walls, floors or wherever "live" electrical wires may be encountered, DO NOT TOUCH ANY METAL PARTS OF THE TOOL!
Hold the tool by the insulated grasping surfaces to prevent electric shock if you drill or chip into a "live" wire.**
- 11. Do not touch the bit or parts close to the bit immediately after operation; they may be extremely hot and could burn your skin.**

SAVE THESE INSTRUCTIONS.

Side handle

The side handle can be secured in four positions (right, left, up and down). To secure the side handle, tighten the wing nut securely. Never secure the side handle in other than the above four positions.

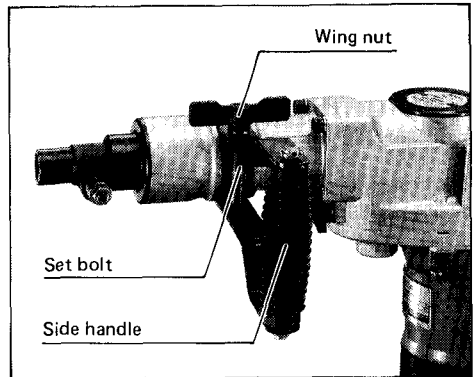

Side grip

The side grip is convenient for downward drilling or chipping operations. Screw the side grip on the tool securely. The side grip can be installed on either side of the tool for right or left hand operation.

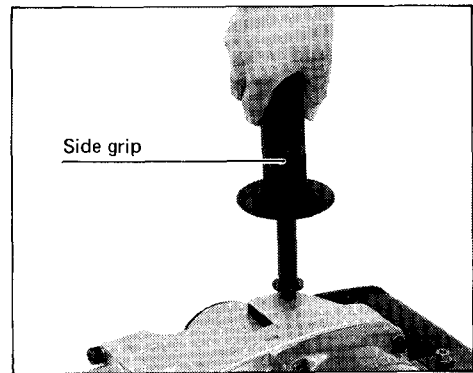

Installing or removing drill bit or other bits (bull point, etc.)

CAUTION:

Always be sure that the tool is switched off and unplugged before installing or removing the bit.

Insert the bit into the tool holder as far as it will go. Pull out and turn the tool retainer 180 degrees. Then release it to secure the bit.

To remove the bit, follow the installation procedure in reverse.

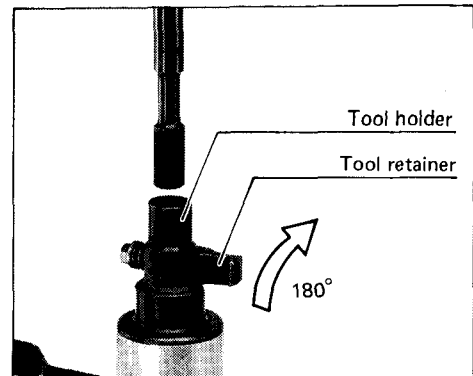

Selecting action mode

Rotation with hammering:

For drilling in concrete, masonry, etc., rotate the change lever to the  position.

Hammering only:

For chipping, scaling or demolition operations, rotate the change lever to the  position.

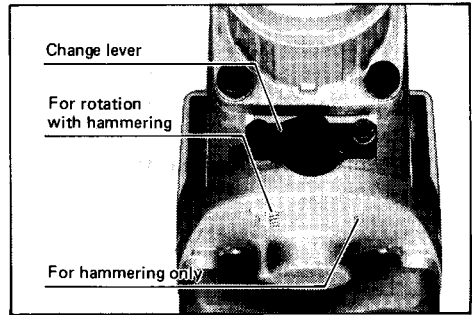

CAUTION:

- Do not rotate the change lever when the tool is running under load. The tool will be damaged.
- To avoid rapid wear on the mode change mechanism, be sure that the change lever is always positively located in one of the two action mode positions.

Switch action

To start the tool, simply pull the trigger. Release the trigger to stop.

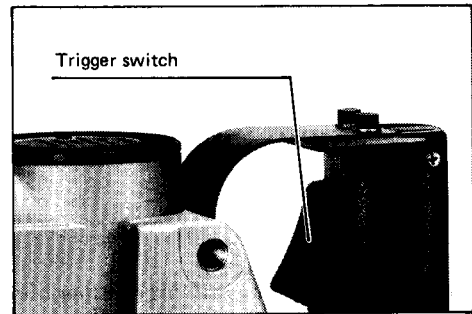

CAUTION:

- Before plugging in the tool, always check to see that the trigger switch actuates properly and returns to the "OFF" position when released.
- Do not tape, tie or otherwise secure the trigger in the "ON" position.

Chipping · Scaling · Demolition

Hold the tool firmly with both hands. Turn the tool on and apply slight pressure on the tool so that the tool will not bounce around, uncontrolled. Pressing very hard on the tool will not increase the efficiency.

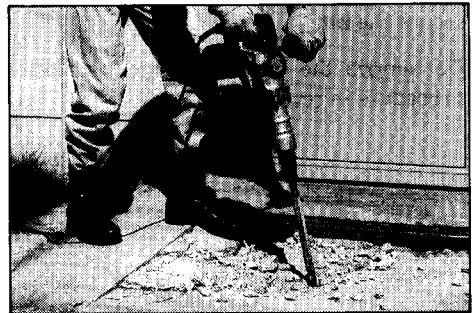

Hammer drilling operation

Position the bit at the location for the hole, then pull the trigger.

Do not force the tool. Light pressure gives best results. Keep the tool in position and prevent it from slipping away from the hole.

Do not apply more pressure when the hole becomes clogged with chips or particles. Instead, run the tool at an idle, then remove from the hole. By repeating this several times, the hole will be cleaned out.

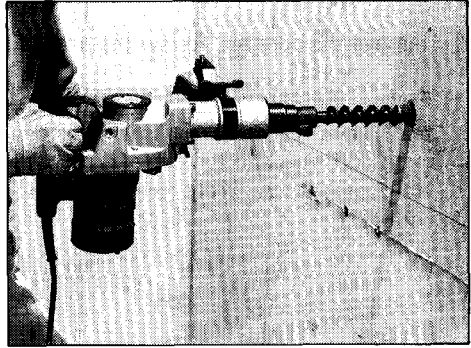

CAUTION:

When the bit begins to break through concrete or if the bit strikes reinforcing rods embedded in concrete, the tool may react dangerously. Maintain good balance and safe footing while holding the tool firmly with both hands to prevent dangerous reaction.

Core bit (optional accessory)

[When using the center bit]

Screw the core bit on the adapter. Install the adapter with the core bit in the tool in the same manner as a drill bit.

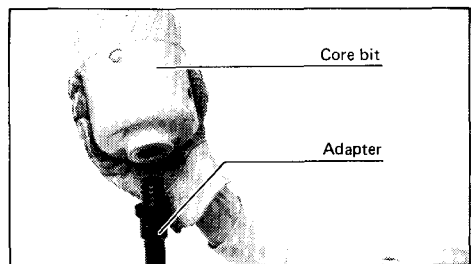

Install the center bit.

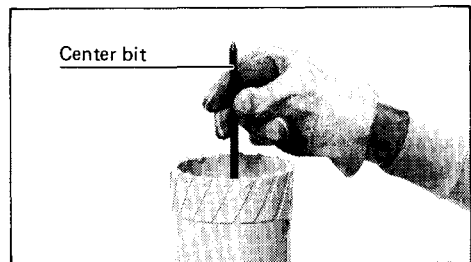

Rest the core bit on the concrete and turn the tool on. Once the core bit has cut a shallow groove into the concrete, remove the center bit. Then resume drilling.

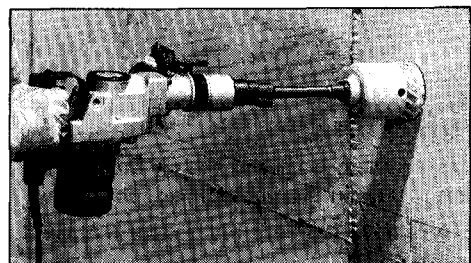

To remove the core bit, follow the procedures (1) or (2).

- 1) Rotate the change lever to the  position. Then rest the core bit on the concrete and turn the tool on. The core bit will come loose from the hammering action.



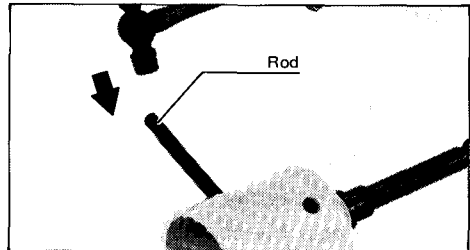

- 2) Hold the adapter with the wrench, insert the rod into the hole in the core bit and tap with a hammer to unscrew.

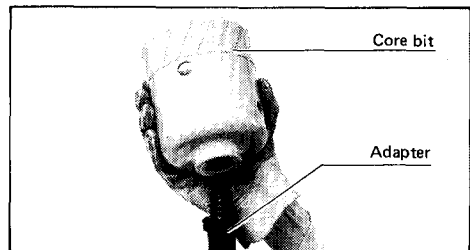

[When not using the center bit]

Screw the core bit on the adapter. Install the adapter with the core bit in the tool in the same manner as a drill bit.



Rotate the change lever to the  position. Rest the core bit on the concrete and turn the tool on. Once the core bit has cut a shallow groove into the concrete, rotate the change lever to the  position and resume drilling.

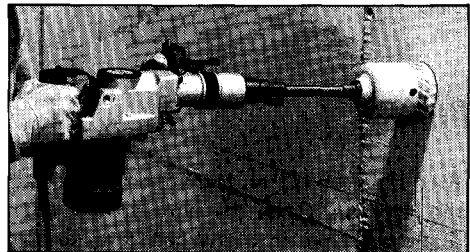

NOTE:

No problem is caused even if the core bit unscrews slightly during brief use since the core bit rotates in the tightening direction.

To remove the core bit, follow the same removal procedures covered in [when using the center bit].

MAINTENANCE

CAUTION:

Always be sure that the tool is switched off and unplugged before attempting to perform inspection or maintenance.

Replacing carbon brushes

When the resin insulating tip inside the carbon brush is exposed to contact the commutator, it will automatically shut off the motor.

When this occurs, both carbon brushes should be replaced at the same time. Use only Makita carbon brushes.

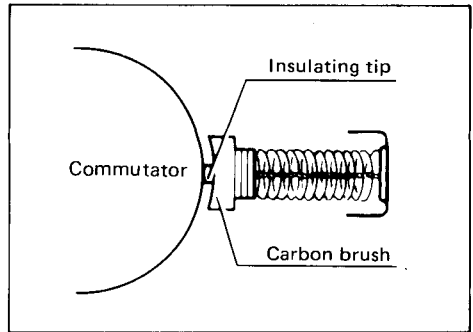

Use a hex wrench to remove the rear cover.

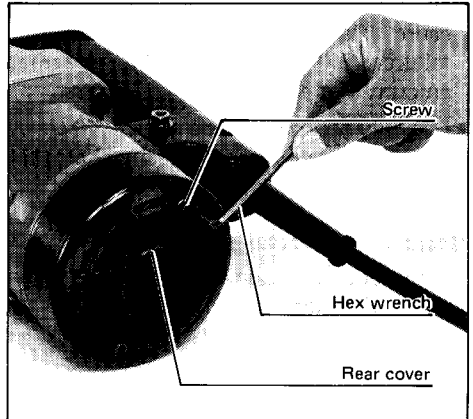

Use a screwdriver to remove the brush holder caps. Take out the worn carbon brushes, insert the new ones and secure the brush holder caps.

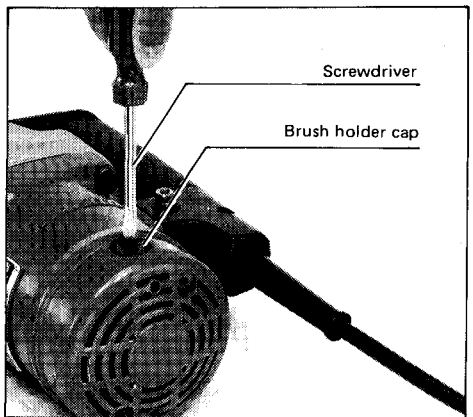

Lubrication

Lubricate the tool every time the carbon brushes are replaced.

Run the tool for several minutes to warm it up, then rest the tool on the table with the bit end pointing upwards. This will allow the old grease to collect inside the crank housing. After five minutes, take off the crank cap and remove the old grease. Wipe out all grease inside and replace with a fresh supply (30 g; 1 oz.).

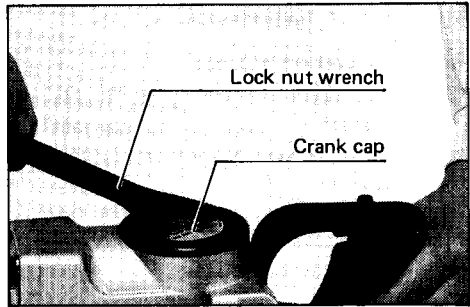

CAUTION:

- Filling with more than the specified amount of grease (approx. 30 g; 1 oz.) can cause faulty hammering action or tool failure. Fill only with the specified amount of grease.
- Use only Makita genuine grease. The use of any other grease may harm the tool.



Sharpening tungsten-carbide tip bit

When your bit becomes dull, use an ordinary bench grinder with a wheel made of silicon carbide to sharpen it.

CAUTION:

- Be sure to maintain the original angles of the tip. Especially without 60° chamfering, the tungsten-carbide tip may be damaged.
- Do not quench the bit in water or oil.
- Do not grind the sides B and C.

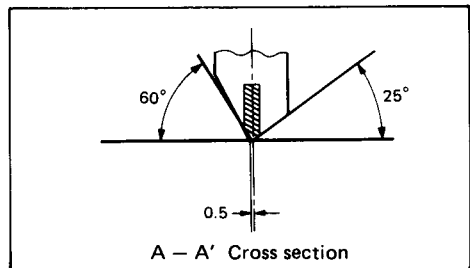
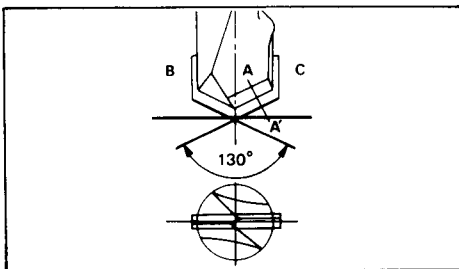

To maintain product SAFETY and RELIABILITY, repairs, any other maintenance or adjustment should be performed by Makita Authorized or Factory Service Centers, always using Makita replacement parts.

ACCESSORIES

CAUTION:

These accessories or attachments are recommended for use with your Makita tool specified in this manual. The use of any other accessories or attachments might present a risk of injury to persons. The accessories or attachments should be used only in the proper and intended manner.

- **Tungsten-carbide tipped (hammer) bit**



Part No.	Bit diameter (mm)	Max. drilling depth (mm)	Overall length (mm)		
791122-4	19 (3/4")	255 (10")	380 (15")		
791123-2	20 (13/16")				
791124-0	22 (7/8")				
791125-8	25.5 (1")				
791126-6	28 (1-1/8")				
791127-4	32 (1-1/4")				
791128-2	35 (1-3/8")				
791129-0	38 (1-1/2")				
791132-1	19 (3/4")			400 (15-3/4")	525 (20-11/16")
791133-9	20 (13/16")				
791134-7	22 (7/8")				
791135-5	25.5 (1")				
791136-3	28 (1-1/8")				
791137-1	32 (1-1/4")				
791138-9	35 (1-3/8")				
791139-7	38 (1-1/2")				
791213-1	19 (3/4")	575 (22-5/8")	700 (27-9/16")		

- **Grooving chisel**

22 mm (55/64") x 300 mm (11-7/8")
Part No. 798142-9

26 mm (1") x 300 mm (11-7/8")
Part No. 798143-7



- **Clay spade**

105 mm (4-1/8") x 400 mm (15-3/4")
Part No. 798148-7



- **Rammer**

140 mm (5-1/2") Part No. 798149-5

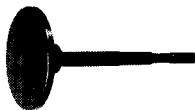

- **Cold chisel**

26 mm (1") x 300 mm (11-7/8")
Part No. 798139-8

26 mm (1") x 450 mm (17-3/4")
Part No. 798140-3



- **Scaling chisel**

50 mm (2") x 300 mm (11-7/8")
Part No. 798141-1



- **Bull point**

300 mm (11-7/8") Part No. 798146-1
450 mm (17-3/4") Part No. 798147-9



- **Bushing tool**

Part No. 798144-5



- **Core bit adapter**

Part No. 798138-0



- **Center bit**

Part No. 752027-3



● Core bit



Part No.	Overall length (mm)	Outer diameter (mm)	Max. drilling depth (mm)
798151-8	150 (5-7/8")	40 (1-9/16")	315 (12-3/8")
798046-5		45 (1-3/4")	
798047-3		54 (2-1/8")	
798048-1		79 (3-1/8")	
798049-9		105 (4-1/8")	
798050-4		118 (4-5/8")	

● Hex wrench 4

Part No. 783202-0



● Hex wrench 6

Part No. 783204-6



● Steel carrying case

Part No. 181997-3



● Rod

Part No. 256815-5



● Hammer grease 30 cc

Part No. 181490-7



● Hex wrench 5

Part No. 783203-8



● Lock nut wrench 35

Part No. 782407-9



● Grip 32

Part No. 273472-4



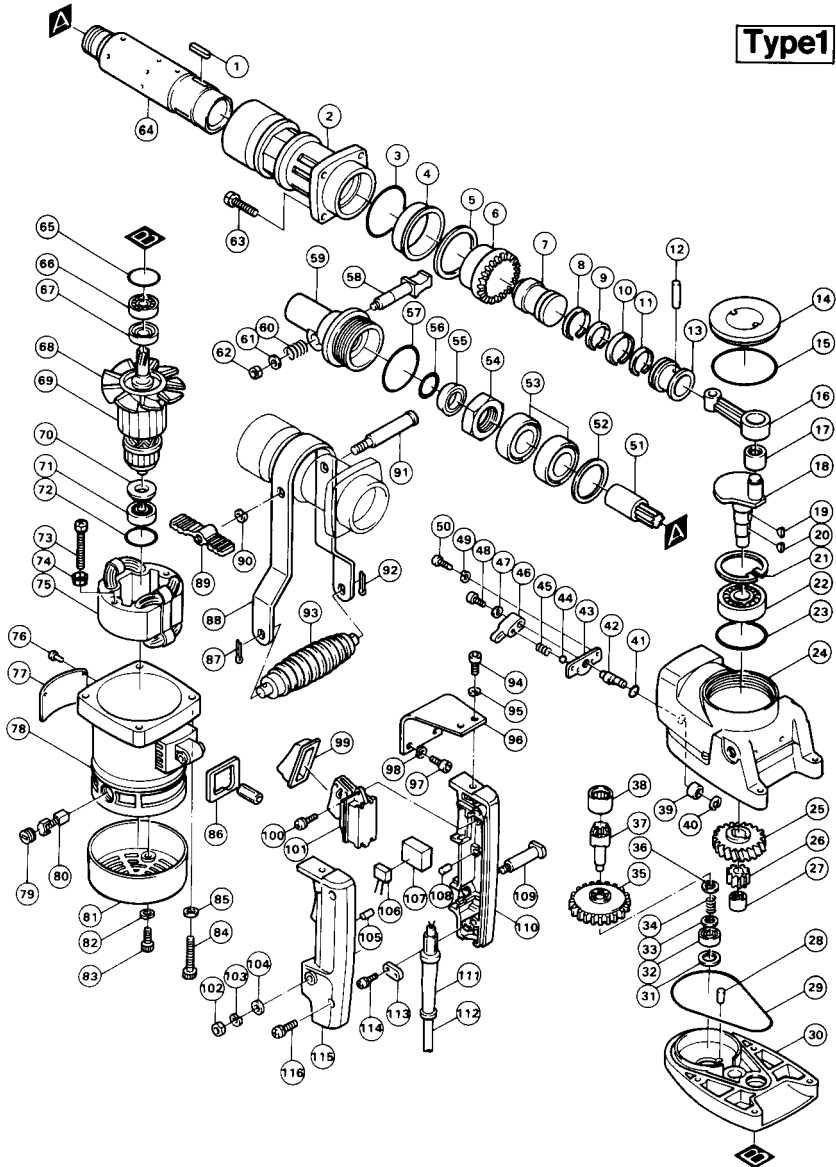

50 mm (2") ROTARY HAMMER Model HR5000

Type1

Note: The switch, noise suppressor and other part configurations may differ from country to country.

ITEM NO.	NO. USED	DESCRIPTION	ITEM NO.	NO. USED	DESCRIPTION
MACHINE			MACHINE		
1	3	Key 4	59	1	Tool Holder
2	1	Barrel	60	1	Compression Spring 15
3	1	O Ring 65	61	1	Flat Washer 8
4	1	Plane Bearing 52	62	1	Hex. Nut M8
5	1	Flat Washer 52	63	4	Hex. Socket Head Bolt M8x30 (With Washer)
6	1	Spiral Bevel Gear 41	64	1	Cylinder Liner 40
7	1	Stricker	65	1	O Ring 32
8	1	Piston Ring 40	66	1	Ball Bearing 6201
9	1	Inner Ring 36	67	1	Oil Seal 14
10	1	Piston Ring 40	68	1	Fan 94
11	1	Inner Ring 36	69	1	ARMATURE ASSEMBLY (With Item 68 - 71)
12	1	Pin 10			
13	1	Piston	70	1	Insulation Washer
14	1	Crank Cap	71	1	Ball Bearing 6200VV
15	1	O Ring 71	72	1	O Ring 30
16	1	Connecting Rod	73	2	Hex. Bolt M5x55
17	1	Needle Bearing 1516	74	2	Lock Washer 5
18	1	Crank Shaft	75	1	FIELD ASSEMBLY
19	2	Woodruff Key 4	76	4	Rivet 0-5
20	1	Woodruff Key 4	77	1	Name Plate
21	1	Retaining Ring R-52	78	1	Motor Housing
22	1	Ball Bearing 6304	79	2	Brush Holder Cap
23	1	O Ring 53	80	2	Carbon Brush
24	1	Crank Housing	81	1	Rear Cover
25	1	Helical Gear 41	82	2	Spring Washer 5
26	1	Spur Gear 24	83	2	Hex. Socket Head Bolt M5x16
27	1	Needle Bearing 1212	84	4	Hex. Socket Head Bolt M6x55
28	1	Rubber Pin 6	85	4	Flat Washer 6
29	1	O Ring 114	86	1	Rubber Sheet
30	1	Gear Housing	87	1	Split Pin 3.0-20
31	1	Flat Washer 16	88	1	Side Handle
32	1	Ball Bearing 638	89	1	Wing Nut M10
33	1	Flat Washer 8	90	1	Spring Washer 10
34	1	Compression Spring 12	91	1	Set Bolt M10x20
35	1	Torque Limiter	92	1	Split Pin 3.0-20
36	1	Thin Washer 10	93	1	Grip 38
37	1	Gear	94	2	Hex. Socket Head Bolt M6x14
38	1	Needle Bearing 2216	95	2	Spring Washer 6
39	1	Needle Bearing 609	96	2	Cushion Plate
40	1	Stop Ring E-4	97	2	Hex. Socket Head Bolt M6x14
41	1	O Ring 10	98	2	Spring Washer 6
42	1	Change Shaft	99	1	Dust Cover
43	1	Plate	100	1	Pan Head Screw M4x16 (With Washer)
44	1	Steel Ball 4.8	101	1	Switch
45	1	Compression Spring 3	102	1	Hex. Nut M6
46	1	Change Lever	103	1	Spring Washer 6
47	1	Flat Washer 4	104	1	Flat Washer 6
48	1	Hex. Socket Head Bolt M4x16 (With Washer)	105	1	Rubber Pin 4
49	2	Spring Washer 5	108	1	Rubber Pin 4
50	2	Hex. Socket Head Bolt M5x12	109	1	Handle Shaft
51	1	Impact Bolt	110	1	Handle Set (With Item 115)
52	1	Flat Washer 43	111	1	Cord Guard
53	2	Ball Bearing 6907	112	1	Cord
54	1	Hex. Nut M34.8-41	113	1	Strain Relief
55	1	X Ring 28	114	2	Pan Head Screw M4x18 (With Washer)
56	1	O Ring 27	115	1	Handle Set (With Item 110)
57	1	O Ring 55	116	2	Pan Head Screw M5x25 (With Washer)
58	1	Tool Retainer			

Note: The switch and other part specifications may differ from country to country.

MAKITA LIMITED ONE YEAR WARRANTY

Warranty Policy

Every Makita tool is thoroughly inspected and tested before leaving the factory. It is warranted to be free of defects from workmanship and materials for the period of ONE YEAR from the date of original purchase. Should any trouble develop during this one-year period, return the COMPLETE tool, freight prepaid, to one of Makita's Factory or Authorized Service Centers. If inspection shows the trouble is caused by defective workmanship or material, Makita will repair (or at our option, replace) without charge.

This Warranty does not apply where:

- repairs have been made or attempted by others;
- repairs are required because of normal wear and tear;
- The tool has been abused, misused or improperly maintained;
- alterations have been made to the tool.

IN NO EVENT SHALL MAKITA BE LIABLE FOR ANY INDIRECT, INCIDENTAL OR CONSEQUENTIAL DAMAGES FROM THE SALE OR USE OF THE PRODUCT. THIS DISCLAIMER APPLIES BOTH DURING AND AFTER THE TERM OF THIS WARRANTY.

MAKITA DISCLAIMS LIABILITY FOR ANY IMPLIED WARRANTIES, INCLUDING IMPLIED WARRANTIES OF "MERCHANTABILITY" AND "FITNESS FOR A SPECIFIC PURPOSE," AFTER THE ONE-YEAR TERM OF THIS WARRANTY.

This Warranty gives you specific legal rights, and you may also have other rights which vary from state to state. Some states do not allow the exclusion or limitation of incidental or consequential damages, so the above limitation or exclusion may not apply to you. Some states do not allow limitation on how long an implied warranty lasts, so the above limitation may not apply to you.



Makita Corporation of America

Buford, GA

883643 - 998

PRINTED IN JAPAN

1989 - 11 - N

Free Manuals Download Website

<http://myh66.com>

<http://usermanuals.us>

<http://www.somanuals.com>

<http://www.4manuals.cc>

<http://www.manual-lib.com>

<http://www.404manual.com>

<http://www.luxmanual.com>

<http://aubethermostatmanual.com>

Golf course search by state

<http://golfingnear.com>

Email search by domain

<http://emailbydomain.com>

Auto manuals search

<http://auto.somanuals.com>

TV manuals search

<http://tv.somanuals.com>