

TECHNICAL INFORMATION



PRODUCT

P 1 / 13

Model No. ▶ BFL201F

Description ▶ Cordless Angle Screwdriver 14.4V

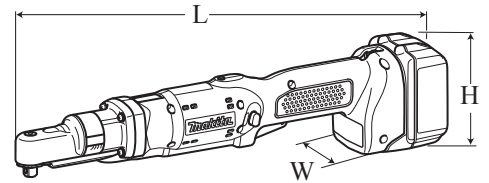

CONCEPT AND MAIN APPLICATIONS

This cordless angle screwdriver for fastening works in assembling line is developed as an advanced model of BFL200F.

Additionally to the same tool durability and high fastening torque accuracy as the current series models, these products feature a powerful and efficient power source and power unit, namely 14.4V/ 3.0Ah Li-ion battery* and BLDC motor (Brushless DC motor).

*BL1430 and BL1430A can be used,
but 1.3Ah Li-ion battery BL1415 cannot be used.

This product is available in the following specifications with the model number described below.

Dimensions: mm (")	
Length (L)	429 (16-7/8)
Width (W)	72 (2-13/16)
Height (H)	98 (3-7/8)

Model No.	Battery		Battery cover	Charger
	type	quantity		
BFL201FZ	No	No	No	No

► Specification

Specifications		Model	BFL201F
Battery	Voltage: V		14.4
	Capacity: Ah		3.0
	Cell		Li-ion
	Max output: W		370
Torque range: N.m (in.lbs)			8 - 20 (71 - 177)
No load speed: rpm= min-1			360
Driving shank: mm (")			Square 9.5 (3/8)
Soft start			Yes
LED Job light			Yes
Electric brake			Yes
Reversing switch			Yes
Torque adjustment			Yes
Weight according to EPTA-Procedure 01/2003* : kg (lbs)			1.7 (3.8)

* with Battery BL1430

► Standard equipment

No

► Optional accessories

Battery BL1430	Auto refresh adapter ADP03
Battery BL1430A	Battery protector (for BL1430A)
Fast charger DC18RA	Protectors (red/ blue/ yellow/ clear)
Charger DC18SD	Torque adjust tool
Charger DC24SC	Angle head set
Automotive Charger DC18SE	

► **Repair**

CAUTION: Repair the machine in accordance with “Instruction manual” or “Safety instructions”.

[1] NECESSARY REPAIRING TOOLS

Code No.	Description	Use for
1R041	Vise plate	Protecting parts when holding in vise
1R034	Bearing setting plate 12.2	Installing Ball bearing 6900LLB
1R145	L-type torx wrench	Loosening/tightening M5x10 Torx countersunk head screw
1R173	Retaining ring R pliers RT-1	Removing/installing Retaining ring R-22
1R219	Torque wrench shaft 7-23N.m	Installing Bearing retainer
1R220	Ratchet head 9.5 (for 1R219)	Installing Bearing retainer
1R222	Socket adapter	Installing Bearing retainer
1R269	Bearing extractor	Removing Ball bearing 6900LLB
1R288	Screwdriver Magnetizer	Magnetizing Screwdriver for removing Steel balls
1R291	Retaining ring S and R pliers	Removing/installing Retaining ring S-10
1R314	Torx bit VT-25	Loosening/tightening M5x10 Torx countersunk head screw
134861-3	Socket 24-45	Installing Bearing retainer
765027-4	Torque adjust tool	Disassembling Clutch assembly
783204-6	Hex wrench 6 (flats width: 6mm)	Loosening/tightening Adjust ring complete

[2] LUBRICATIONS/ GLUING

Apply Makita grease N.No.2/ Loctite 603 to the portions designated by arrows.

Item No.	Description	Portion to lubricate	Lubricant	Amount
⑬	Spindle	Left hand where M12 Lock nut contacts	Makita grease N.No.2 ▼	a little
⑳	Spindle A complete	Gear teeth that engages with Spiral bevel gear 9		2g
⑭	Steel ball 5.0 (3pcs.)	Whole surface		a little
⑰	Steel ball 4 (3pcs.)			
⑲	Steel ball 3 (13pcs.)			
⑳	O ring 14			
⑳	Carrier complete B	Three shaft pins		2g in total
④①	Spur gear 18 (3pcs.)	Gear teeth		
④①	Spur gear 9 complete A	Gear teeth and three shaft pins		
④②	Spur gear 18 (3pcs.)	Gear teeth		

Fig. 1

Item No.	Description	Portion to glue	Adhesive	Amount
②	M4x22 Pan head screw (4pcs.)	Thread	Loctite 603 ▼	a little
⑳	Torx C.S.H. screw M5x10			
⑳	M4x8 Pan head screw			
③⑥	Bearing retainer 14-23			
⑧⑥	M3x20 Pan head screw (7pcs.)			

Note: Part No. for ④① is different from that for ④②.

► **Repair**

[3] DISASSEMBLY/ASSEMBLY

[3]-1. LED job light section

DISASSEMBLING

- 1) Remove Light cover by unscrewing two M4x8 Pan head screws. (Fig. 2)
- 2) Remove LED circuit and its Lead wires from Light holder, and disconnect Connector of LED circuit with that of Motor control unit. Switch lever and Compression spring 2 can be removed in this step. (Fig. 3)

Fig. 2

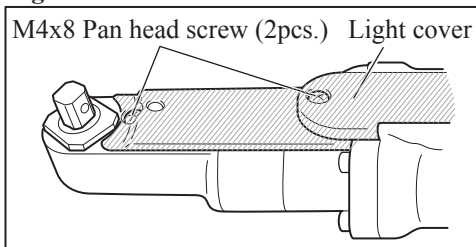
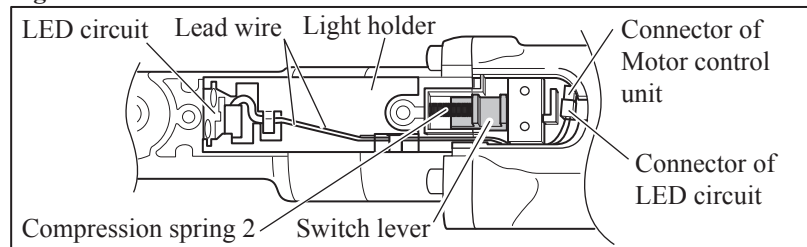

Fig. 3



ASSEMBLING

- 1) Connect Connector of LED circuit with that of Motor control unit. and put LED circuit in place on Light holder. Then fix lead wires with Lead holders as illustrated in Fig. 4.
 - 2) Fitting the protruding portion of Light cover in the notch of Angle head complete, assemble Light cover to Angle head complete by screwing two M4x8 Pan head screws. (Fig. 5)
- Note:** Be careful not to pinch the slack portion of Lead wires between Light cover and Angle head complete.

Fig. 4

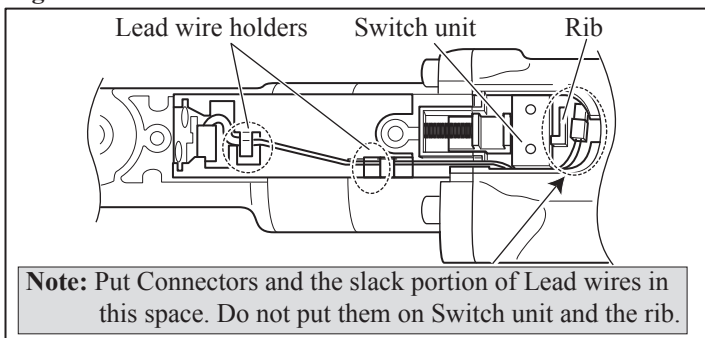
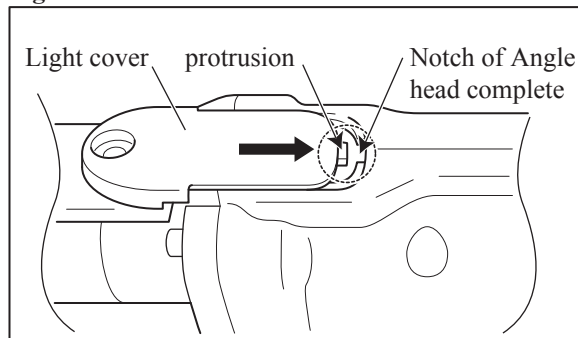

Fig. 5



[3] -2. Spindle A complete section

DISASSEMBLING

- 1) Remove Bearing retainer 14-23 from Angle head complete by turning clockwise with wrench of 24mm flats width.(Fig. 6) Spindle A complete section can now be removed by pulling by hand. (Fig. 7)
- 2) Remove Flat washer 6 from Spindle A complete. (Flat washer 6 may remain in Angle head complete.) Remove Spindle A complete from Bearing retainer 14-23 by pushing down Bearing retainer 14-23 in the direction of the arrow by hand. (Fig. 8)

Note: If cannot be removed by hand, disassemble by pressing down Spindle A complete using arbor press. (Fig. 9)

Fig. 6

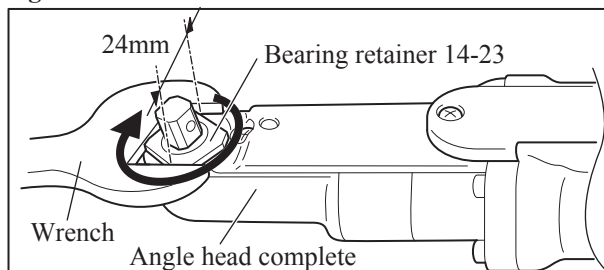

Fig. 7

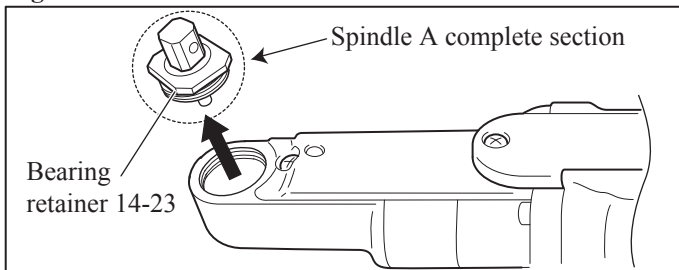

Fig. 8

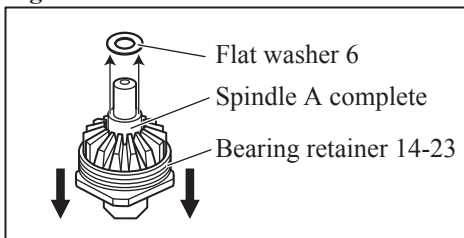
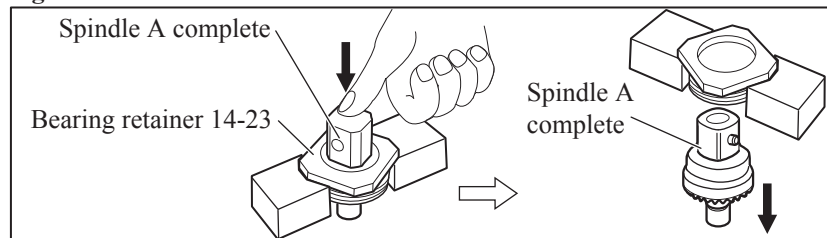

Fig. 9



► Repair

[3] DISASSEMBLY/ASSEMBLY

[3] -2. Spindle A complete section (cont.)

ASSEMBLING

1) Apply Makita grease N.No.2 to O ring 14. (**Fig. 1**)

Assemble O ring 14, Flat washer 14 then Spindle complete to Bearing retainer 14-23 as illustrated in **Fig. 10**.

Note: If you cannot assemble Spindle complete to Bearing retainer 14-23 by hand, do it using arbor press as illustrated in **Fig. 11**.

2) Apply about 2g of Makita grease N.No.2 to the Gear room of Angle head complete. (**Fig. 1**)

Note: Be careful not to put Makita grease N.No.2 on the threaded portion of Angle head complete.

3) Apply Loctite 603 to the threaded portion of Bearing retainer 14-23. (**Fig. 1**)

Then assemble Flat washer 6 to Spindle complete. (Refer to **Fig. 8**.)

Assembling of Spindle complete section has been completed.

4) Clamp the flats of Angle head complete securely in a vise to which 1 set of 1R041 is attached, then assemble Spindle A complete section to Angle head complete by turning Bearing retainer 14-23 counterclockwise using 1R219, 1R220, 1R222 and 134861-3 as illustrated in **Fig. 11**.

Caution: When clamping Angle head complete, be very careful not to deform it by overtightening.

Fig. 10

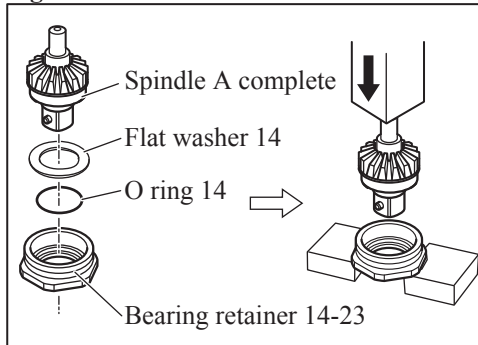
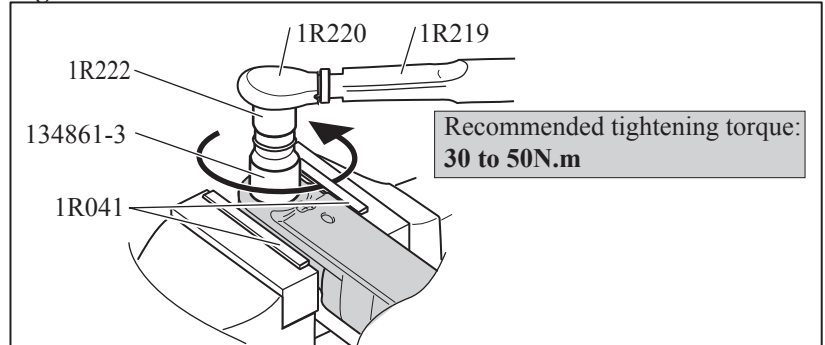

Fig. 11



► **Repair**

[3] DISASSEMBLY/ASSEMBLY

[3] -3. Spiral bevel gear 9 section

DISASSEMBLING

- 1) Remove Light cover by unscrewing two M4x8 Pan head screws, then remove Switch lever and Compression spring 2. (**Fig. 12**)
 - 2) Remove Angle head complete from Housing by unscrewing four M4x22 (+) Pan head screws, then remove Clutch section (= Clutch assembly) from Angle head complete. (**Fig. 13**)
- Note:** Be careful not to lose Compression spring 5, which may pop out from Clutch section when Clutch section is removed from Angle head complete. (**Fig. 13**)

Fig. 12

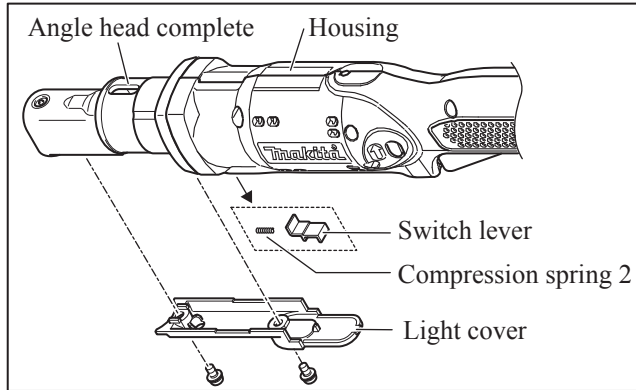
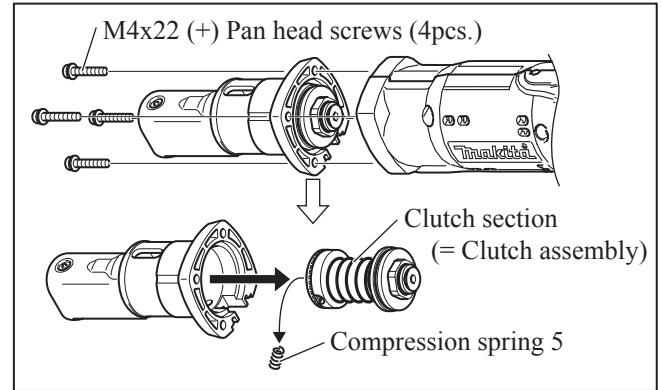

Fig. 13



- 3) Using 1R173, remove Retaining ring R-22 that retains Spiral bevel gear 9 section in Angle head complete. (**Fig. 14**)
Spiral bevel gear 9 section can now be removed by tapping the end surface of Angle head complete with plastic hammer. (**Fig. 15**)

Fig. 14

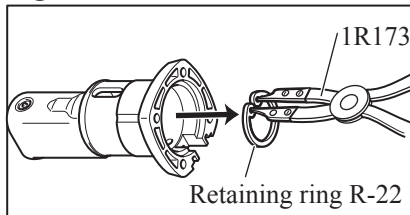
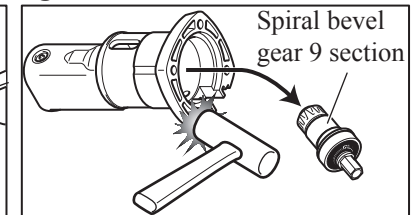
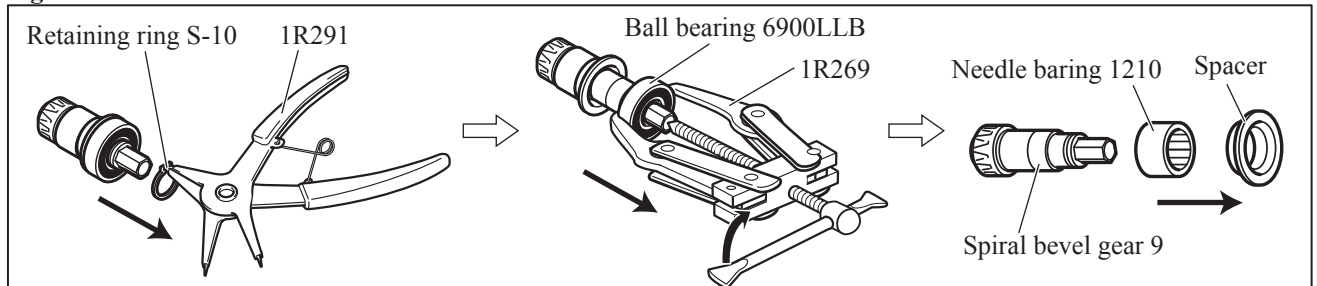

Fig. 15



- 4) Remove Retaining ring S-10 using 1R291, then remove Ball bearing 6900LLB using 1R269. Spacer and Needle bearing 1210 can now be removed from Spiral bevel gear 9. (**Fig. 16**)

Fig. 16



ASSEMBLING

Do the reverse of the disassembling steps. (Refer to **Figs. 16 to 12.**)

Note 1: Spacer is not reversible when assembled to Spiral bevel gear 9.

Be sure to assemble as illustrated to left in **Fig. 17.**

Note 2: Use 1R034 and arbor press when assembling Ball bearing 6900LLB to Spiral bevel gear 9. (**Fig. 18**)

Fig. 17

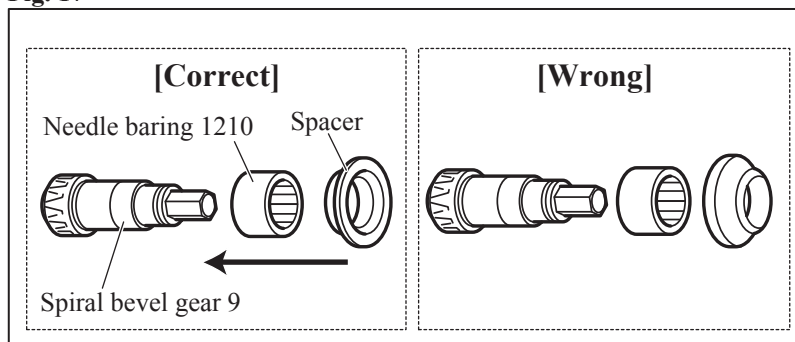
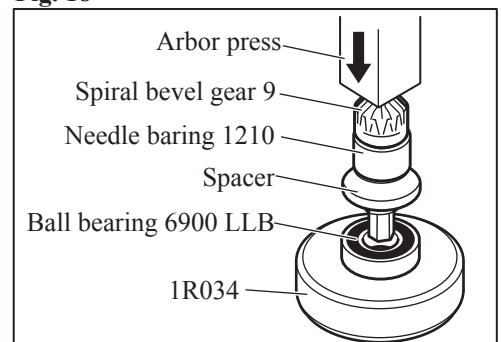

Fig. 18



► Repair

[3] DISASSEMBLY/ASSEMBLY

[3] -4. Clutch section

DISASSEMBLING

Note: When repairing Clutch section, it is recommended to entirely replace Clutch assembly with new one.

However, if required to replace component parts of Clutch assembly, follow the disassembling/assembling procedure described below.

- 1) Take out Clutch section (=Clutch assembly) from Angle head complete. (Refer to **Figs. 12 and 13**)
- 2) Insert 765025-8 into the hole of Adjust ring complete, and turn it counterclockwise to remove M12 Lock nut: the pressure of Compression spring 19H will be decreased, and M12 Lock nut can now be removed by turning it clockwise by hand. (**Fig. 19**)
- 3) Remove Adjust ring complete, Flat washer 18, Compression spring 19H from Spindle. (**Fig. 20**)
- 4) The following Steel balls can be removed as illustrated in **Fig. 21**:
Steel ball 3 (13pcs.), Steel ball 4 (3pcs.), Steel ball 5.0 (3pcs.)

Note: Use a screwdriver magnetized with 1R288 for easy removal of Steel balls.

- 5) Insert short leg of hex wrench 6 into the hole of Spindle, and fix long leg of the hex wrench securely in vise.
Insert No.T25 Torx wrench of L type Torx wrench set (1R145) into the socket of M5x10 Torx countersunk head screw. Then remove the screw by turning M5 Torx wrench counterclockwise as illustrated to **left in Fig. 22**.
The following parts can now be removed from Spindle: Cam D, Cam A on Torx screw side, Flat washer 7. (**right in Fig. 22**)

Fig. 19

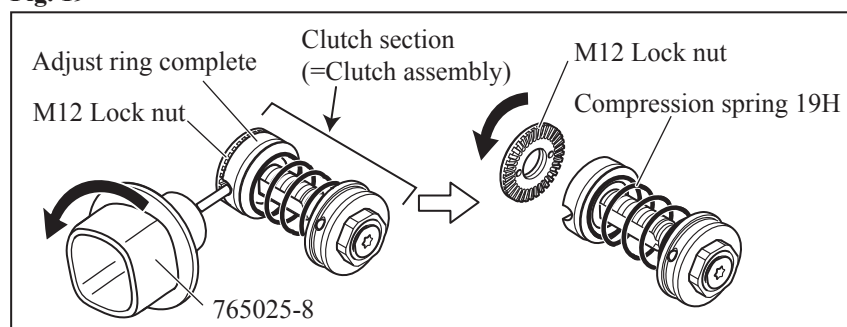

Fig. 20

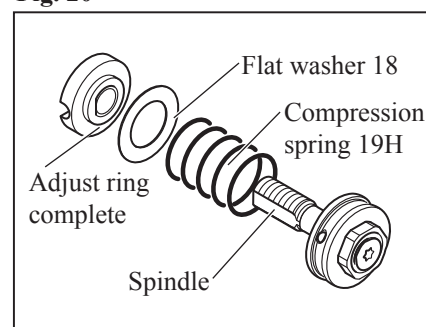

Fig. 21

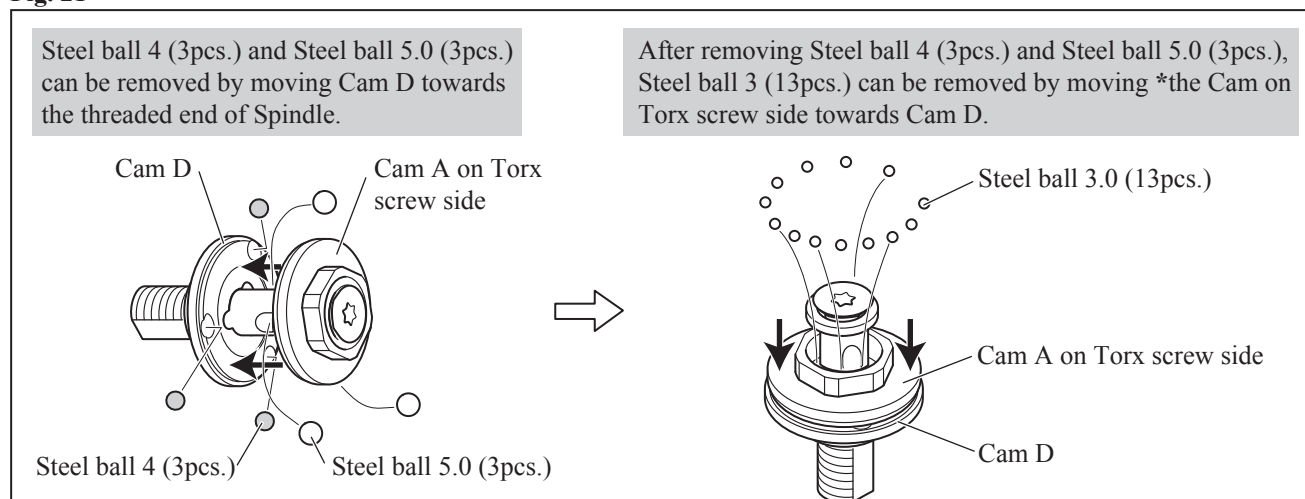
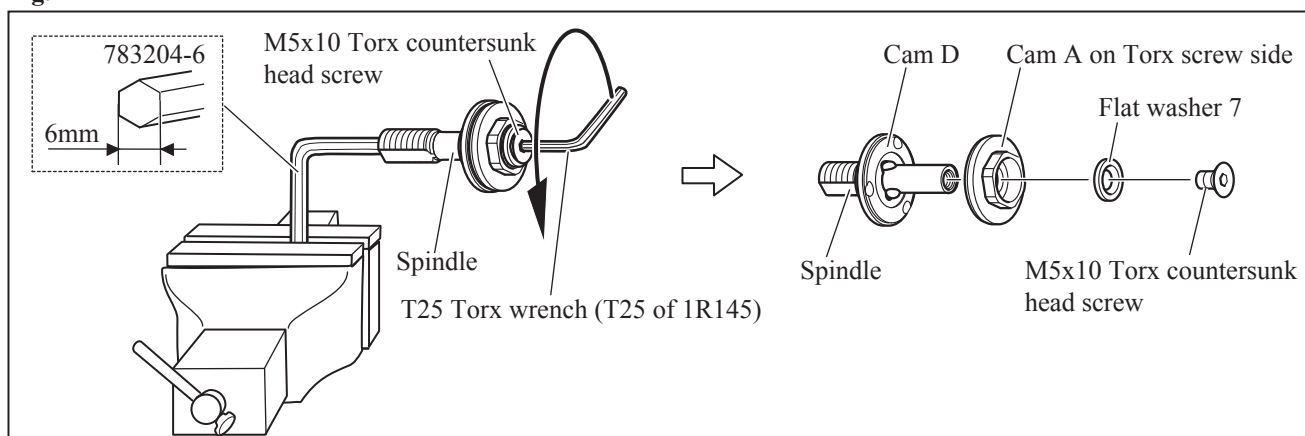

Fig. 22



► **Repair**

[3] DISASSEMBLY/ASSEMBLY

[3] -4. Clutch section (cont.)

ASSEMBLING

Do the reverse of the disassembling steps.

Note:

- When fastening M5x10 Torx countersunk head screw to Spindle, do as described in **Fig. 23**.
- Apply Makita grease N. No.2 to all Steel balls and the Spindle's threaded portion for engaging with M12 Lock nut before assembling. (**Fig. 1**) Be careful not to put the grease in the threaded hole of Spindle.

Fig. 23

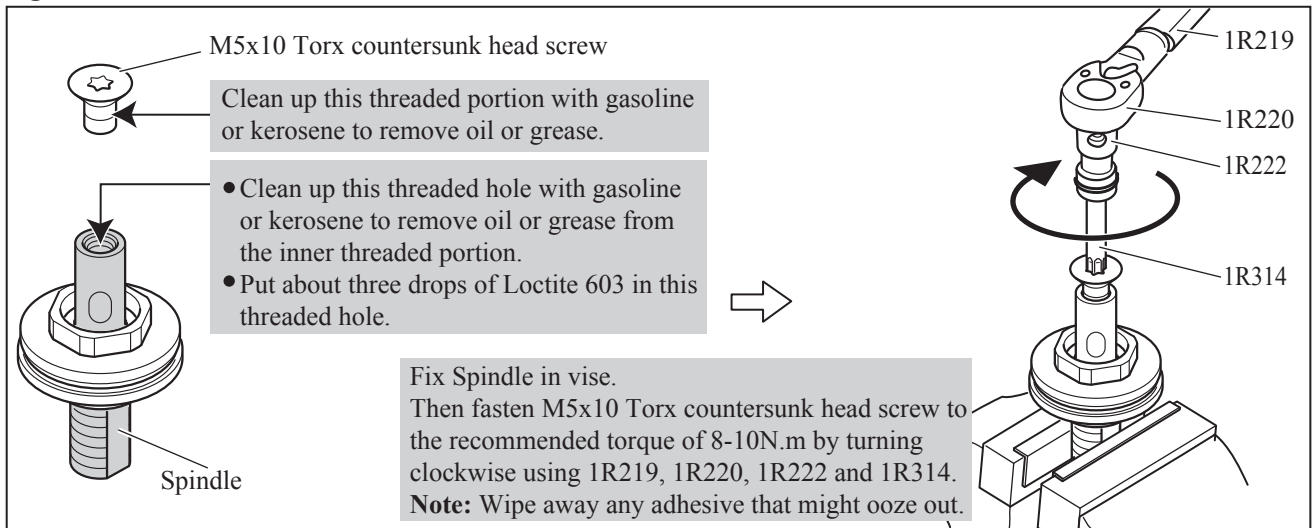

[3] -5. Gear case section

DISASSEMBLING

- 1) Remove Light cover, Switch lever and Compression spring 2. See **[3] -1** on page 5.
- 2) Remove four M4x22 Pan head screws to separate Angle head complete from the machine. (See **[3] -3** on page 7.)
- 3) Remove seven M3x20 Pan head screws to separate Housing (L) from (R).
- 4) Remove Switch unit from Gear case section.
- 5) Separate Gear case section from Motor control unit by first lifting them up, then turning Motor bracket counterclockwise. (**Fig. 24**)
- 6) Pull off Motor bracket from Rotor, and then pull off Rotor from Motor control unit.
- 7) Remove Lock washer located in Gear case by turning counterclockwise with pliers or slotted screwdriver. (**Fig. 25**)
- 8) Remove Spur gears, Internal gear 47, Carrier complete B and Ball bearing 6805LLB.

Fig. 24

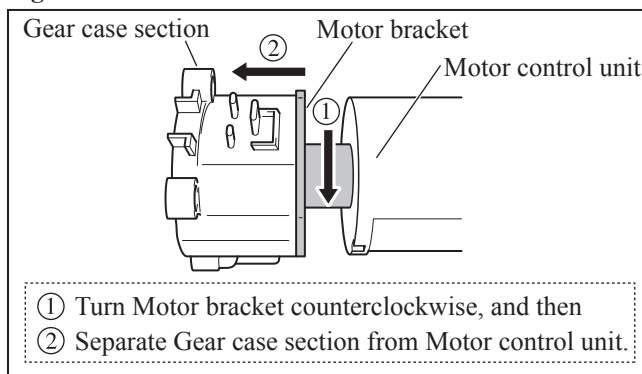
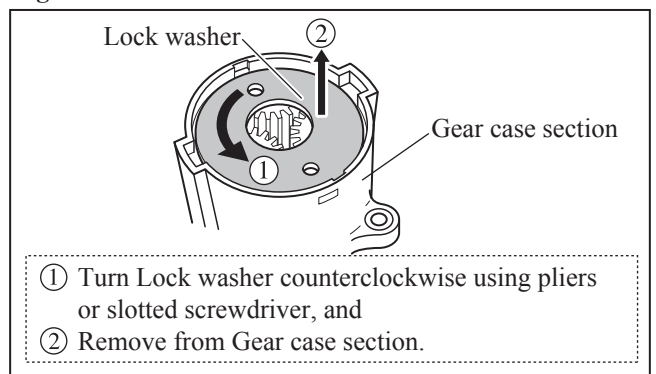

Fig. 25



Caution for Handling Rotor

When handling or storing multiple Rotors, be sure to provide the minimum distances specified in **Fig. 26** between Rotors. Rotor is a strongly magnetic body.

Therefore, failure to follow this instruction could result in:

- Finger injury caused by pinching between Rotors pulling each other
- Magnetic loss of Rotors

Fig. 26

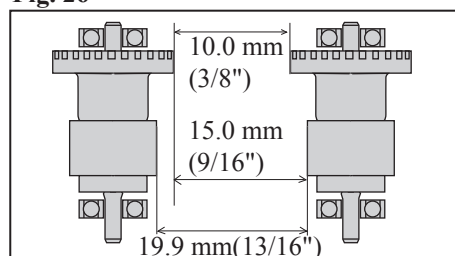

► **Repair**

[3] DISASSEMBLY/ASSEMBLY

[3] -5. Gear case section (cont.)

ASSEMBLING

1) After applying Makita grease N No.2 to teeth of all Spur gears, shafts of Carrier complete B and shafts of Spur gear 9 complete A, assemble Ball bearing 6805LLB and Carrier complete B to Gear case. (Fig. 2) Then assemble Internal gear 47 and Spur gears from the opposite side.

2) Install Rotor on Motor control unit as described below;
Fix Motor control unit on table or the like, and insert Rotor slowly into Motor control unit until it touches the surface of the table. Then lift up Motor control unit gradually until it stops. (Fig. 26)

Caution:

1. Because Rotor is a strong magnet, be sure to remove metal chips or debris from it before installation, be very careful not to pinch your fingers between Rotor and metal parts, etc.
2. Be careful not to shock the printed wiring board of Motor control unit.
- 3) Install Lock washer on Gear case, then put Motor bracket on Gear case, and turn it clockwise to lock in place.

4) Assemble Gear case section and Motor control unit to Housing (R) so that Lead wires of Motor control unit and the Switch unit installation portion on Gear case faces the side of the LED - Trigger switch line. (Fig. 27)

When assembling, fit the boss on Housing (R) in the notch in Motor control unit. (Fig. 28)

5) Set Switch unit in place on Gear case.

6) Assemble the following parts to Housing (R) in numerical order:

1. Controller of Motor control unit
 2. Terminal
 3. LED circuit
 4. Gear case section to which Motor control unit is assembled
- Put Lead wires in place while taking care not to pinch them. After putting Switch section in place, install Plate and Lens. Then fasten Housing (L) to (R) with seven M3x20 Pan head screws. (Fig. 29)

Caution: When disconnecting connectors, do not pull lead wires. (Fig. 30)

Fig. 26

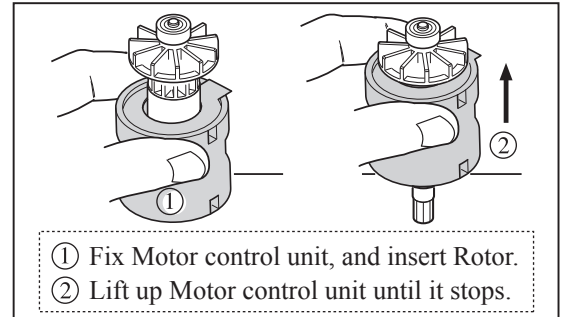

Fig. 27

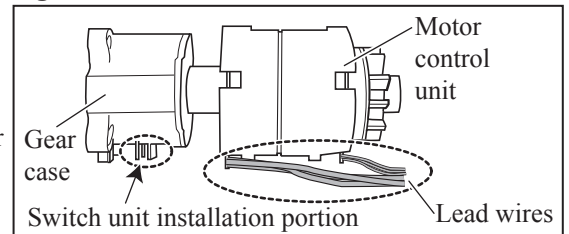

Fig. 28

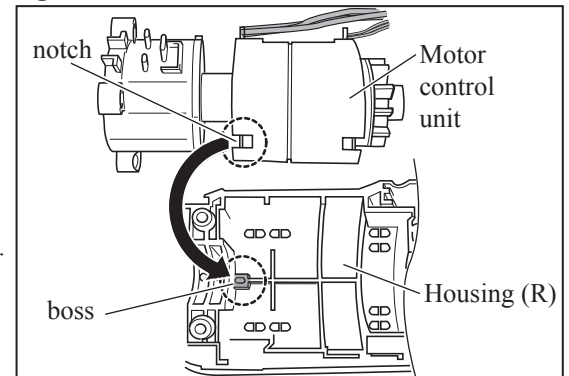

Fig. 29

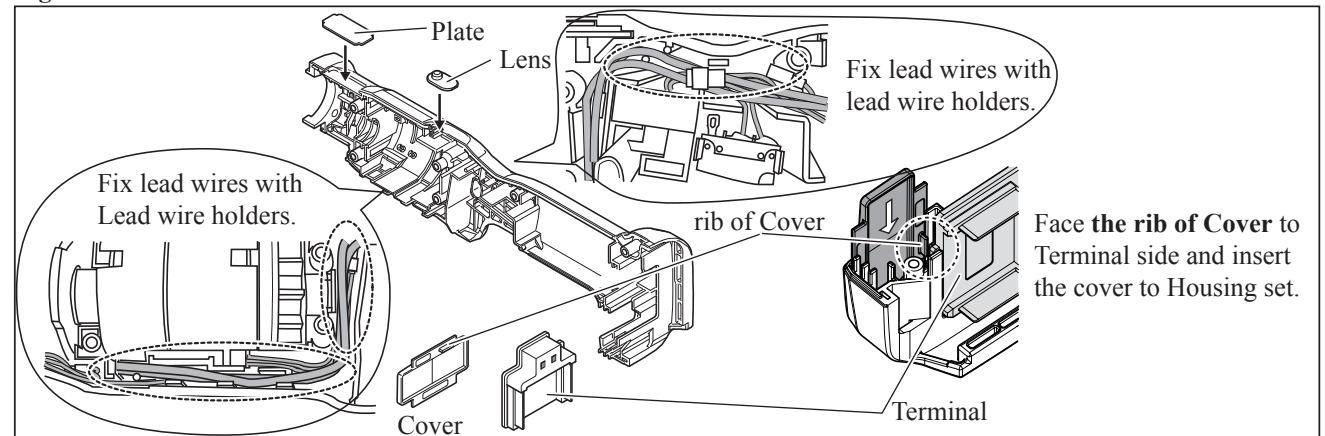
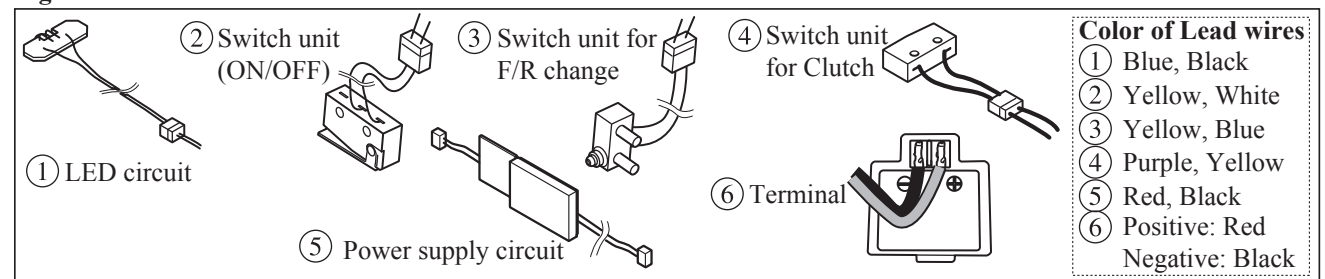

Fig. 30



► Repair

[3] DISASSEMBLY/ASSEMBLY

[3] -6. Switch section

DISASSEMBLING

- (1) Remove Light cover, Compression spring 2 and Switch lever illustrated in **Fig. 12**.
- (2) Separate Angle head complete from Housing set as illustrated in **Fig. 13**. However, no need to remove Clutch assembly.
- (3) Remove Housing set (L) and seven M3x20 Pan head screws, and then remove Switch section as illustrated in **Fig. 31**.

Fig. 31

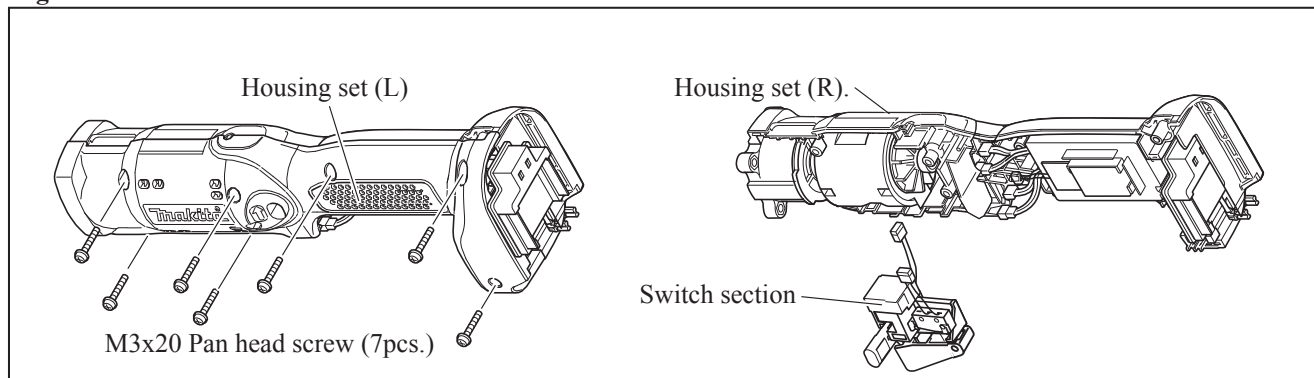

- (4) Remove Switch unit in Trigger while expanding the ribs. (**Fig. 32**)
- (5) Switch unit for rotation reverse can be replaced first by removing PT3x16 Tapping screw, then removing Cover. Now the following parts can also be replaced:
F/R Change lever, Leaf spring, Switch lever (A), Compression spring 4

Fig. 32

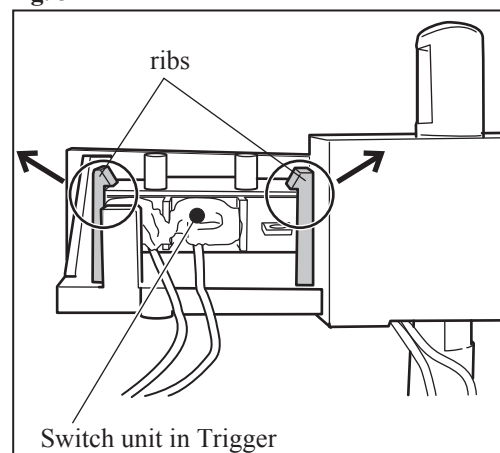

ASSEMBLING

- (1) Put Leaf spring in place on F/R Change lever, and Compression spring 4 on Switch lever A.
- (2) Put F/R Change lever, Switch lever and Switch unit for rotation reverse in place; at this time, fit the protrusion on F/R Change lever in Switch lever A. (**Fig. 33**)
Then, fasten the above parts with PT3x16 Tapping screw while holding them with Cover.

Fig. 33

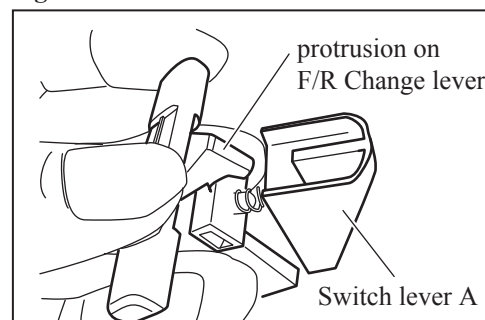

► **Circuit diagram**

Fig. D-1

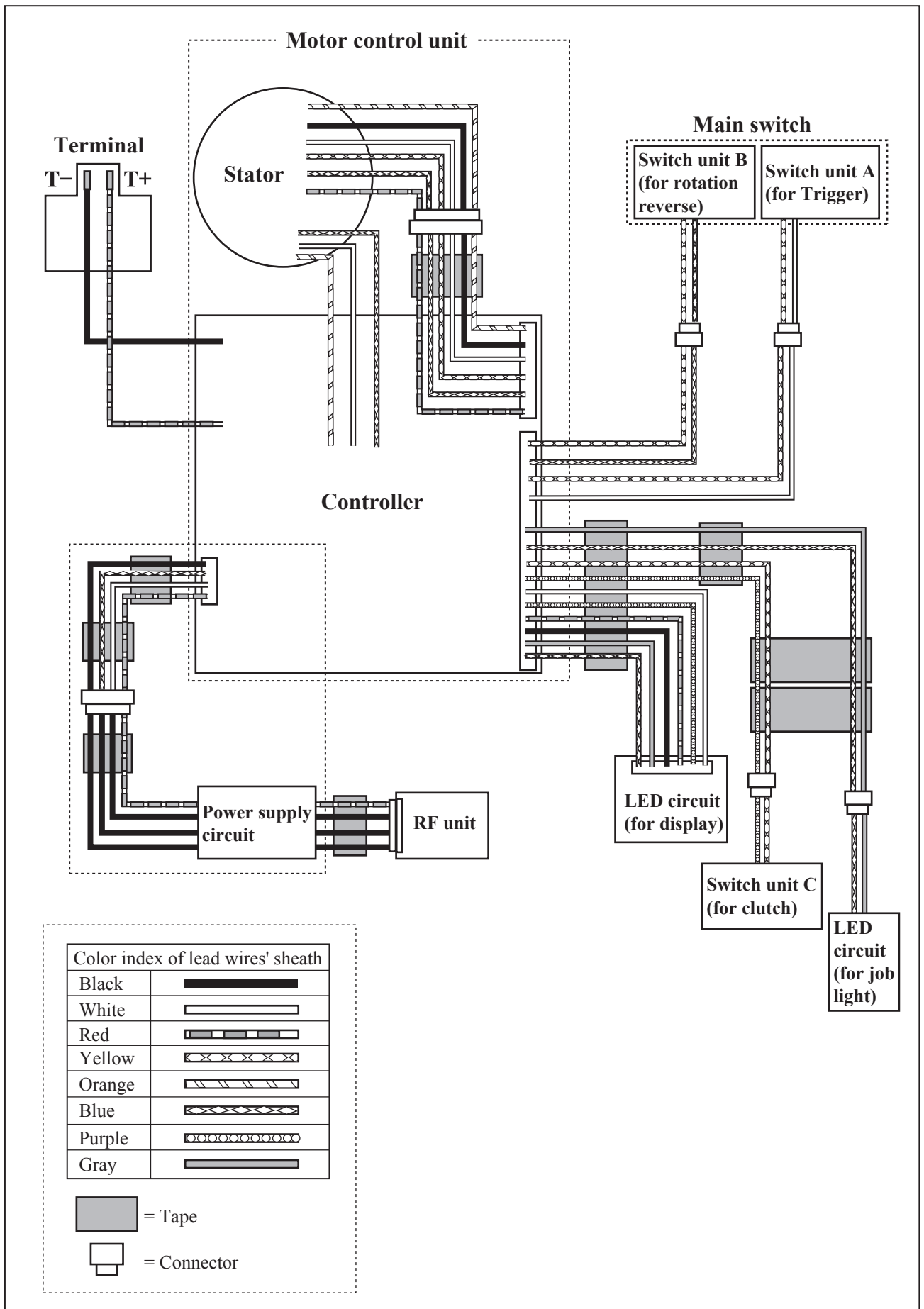

► **Wiring diagram**

Wiring around Controller

Fig. D-2

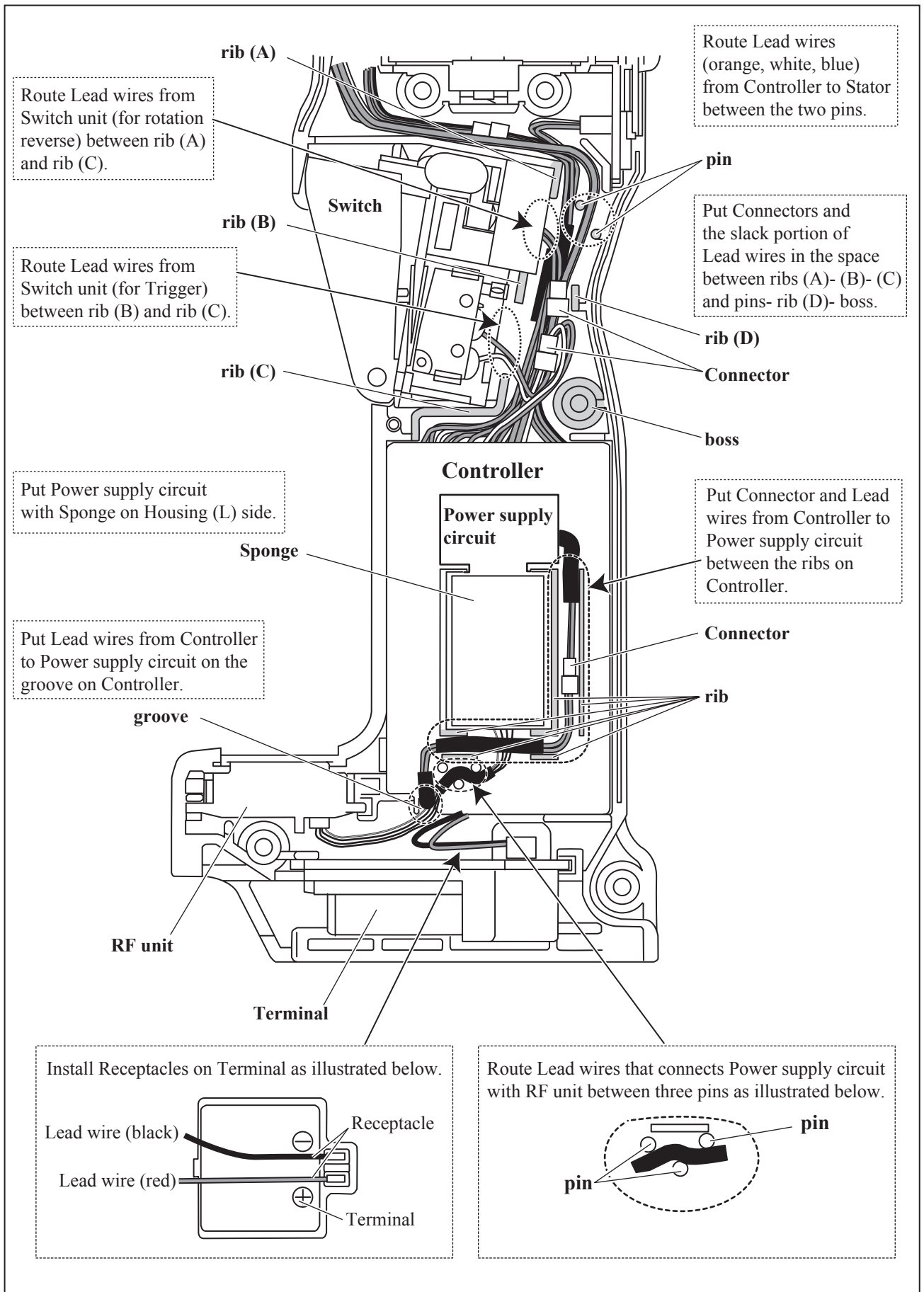

► **Wiring diagram**

[2] **Wiring around Stator**

Fig. D-3

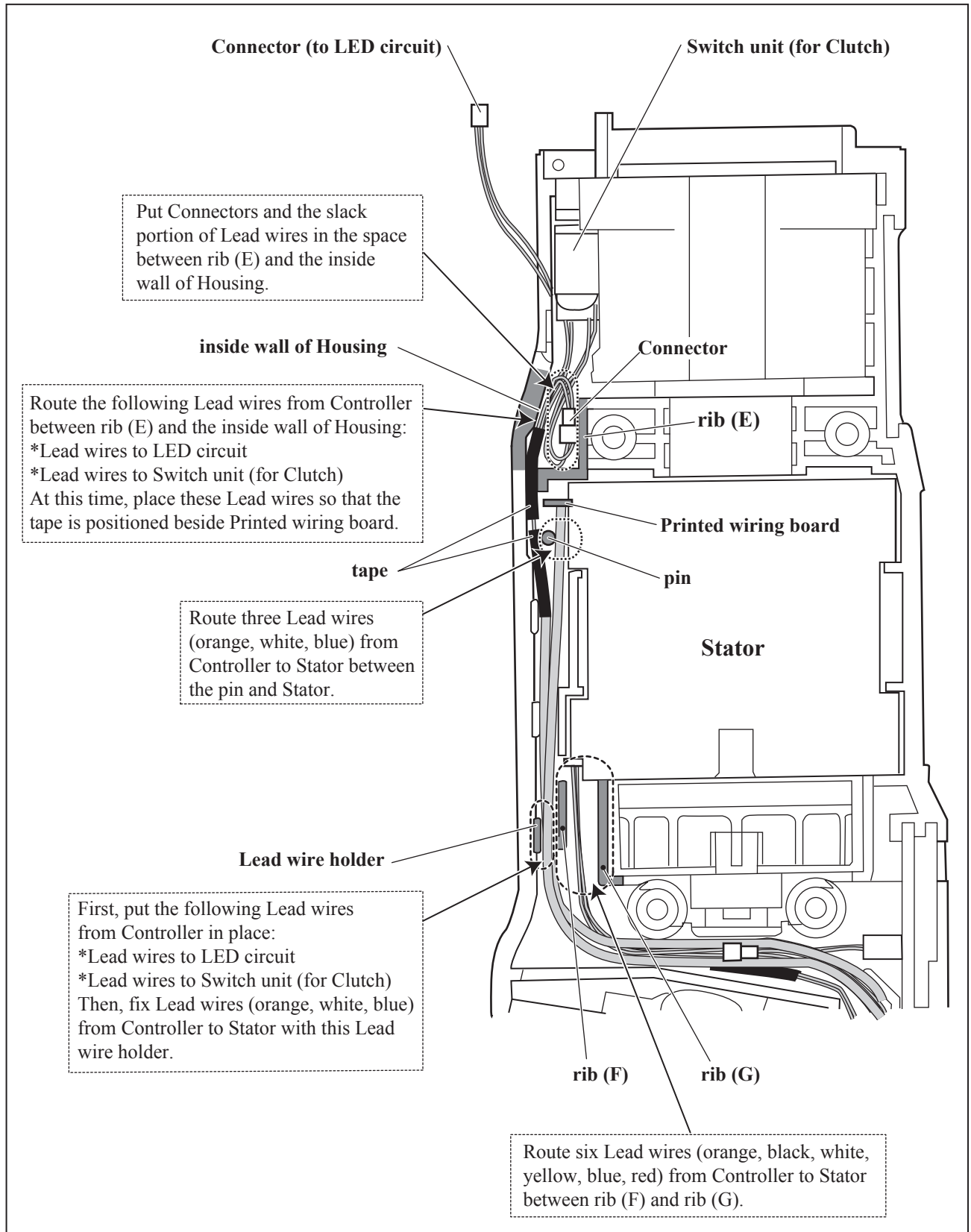

► **Wiring diagram**

Wiring of Lead wires of LED circuit

Fig. 4

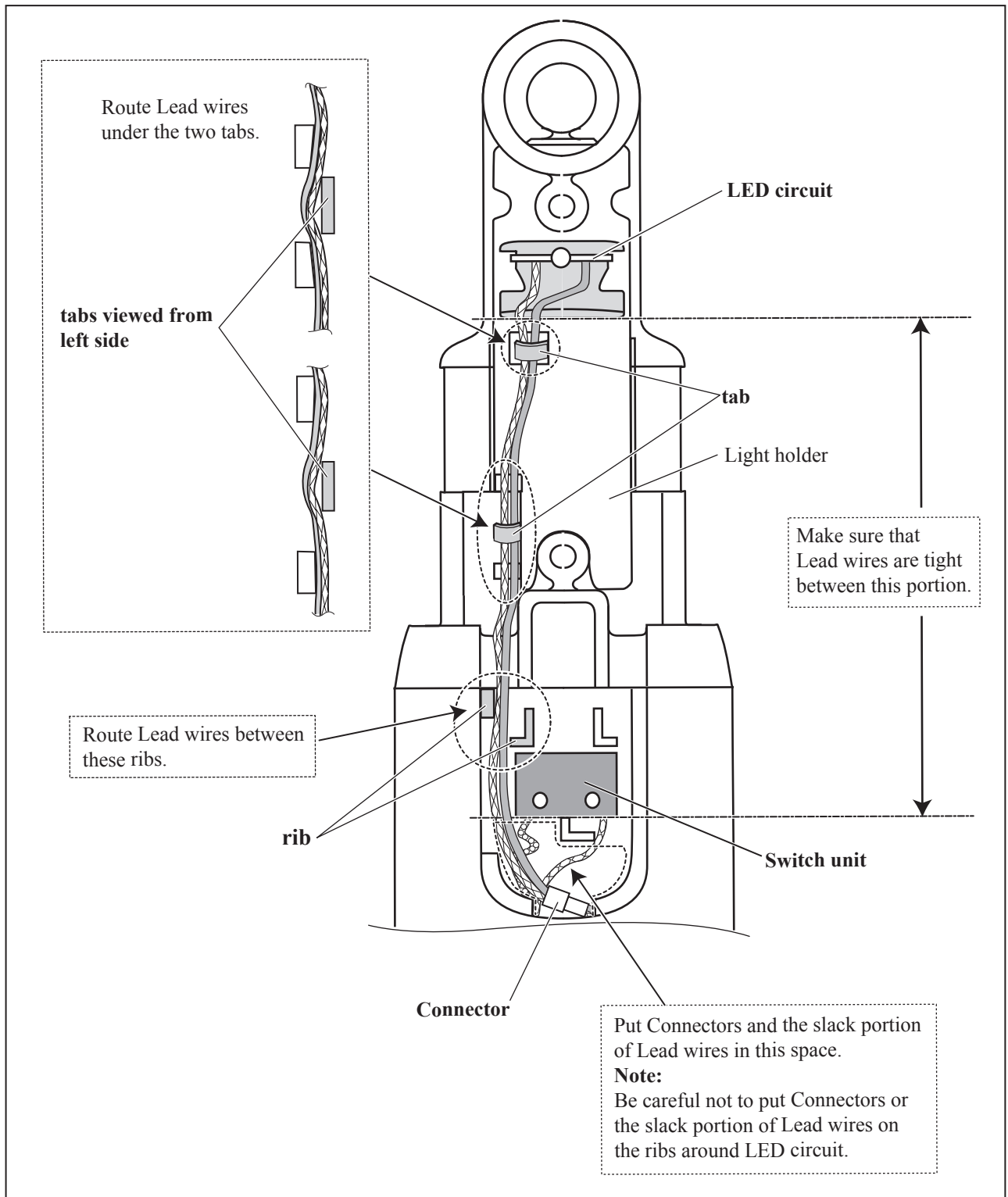

Free Manuals Download Website

<http://myh66.com>

<http://usermanuals.us>

<http://www.somanuals.com>

<http://www.4manuals.cc>

<http://www.manual-lib.com>

<http://www.404manual.com>

<http://www.luxmanual.com>

<http://aubethermostatmanual.com>

Golf course search by state

<http://golfingnear.com>

Email search by domain

<http://emailbydomain.com>

Auto manuals search

<http://auto.somanuals.com>

TV manuals search

<http://tv.somanuals.com>