

Makita

アメリカ

Router

MODEL 3620
MODEL 3620A

Equipped with electric brake

INSTRUCTION MANUAL

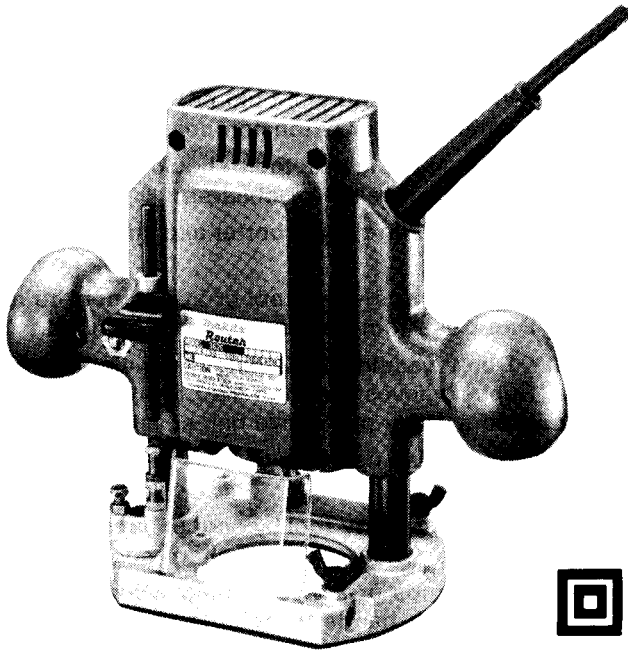

DOUBLE INSULATION

SPECIFICATIONS

Collet chuck capacity	Main body stroke	No load speed (RPM)	Overall length	Net weight
1/4"	35 mm (1-3/8")	24,000	211 mm (8-5/16")	2.4 kg (5.3 lbs)

- * Manufacturer reserves the right to change specifications without notice.
- * Note: Specifications may differ from country to country.

IMPORTANT SAFETY INSTRUCTIONS

(For All Tools)

WARNING: WHEN USING ELECTRIC TOOLS, BASIC SAFETY PRECAUTIONS SHOULD ALWAYS BE FOLLOWED TO REDUCE THE RISK OF FIRE, ELECTRIC SHOCK, AND PERSONAL INJURY, INCLUDING THE FOLLOWING:

READ ALL INSTRUCTIONS.

1. **KEEP WORK AREA CLEAN.** Cluttered areas and benches invite injuries.
2. **CONSIDER WORK AREA ENVIRONMENT.** Don't use power tools in damp or wet locations. Keep work area well lit. Don't expose power tools to rain. Don't use tool in presence of flammable liquids or gases.
3. **KEEP CHILDREN AWAY.** All visitors should be kept away from work area. Don't let visitors contact tool or extension cord.
4. **STORE IDLE TOOLS.** When not in use, tools should be stored in dry, and high or locked-up place — out of reach of children.
5. **DON'T FORCE TOOL.** It will do the job better and safer at the rate for which it was intended.
6. **USE RIGHT TOOL.** Don't force small tool or attachment to do the job of a heavy-duty tool. Don't use tool for purpose not intended.
7. **DRESS PROPERLY.** Don't wear loose clothing or jewelry. They can be caught in moving parts. Rubber gloves and non-skid footwear are recommended when working outdoors. Wear protective hair covering to contain long hair.
8. **USE SAFETY GLASSES.** Also use face or dust mask if cutting operation is dusty.
9. **DON'T ABUSE CORD.** Never carry tool by cord or yank it to disconnect from receptacle. Keep cord from heat, oil, and sharp edges.
10. **SECURE WORK.** Use clamps or a vise to hold work. It's safer than using your hand and it frees both hands to operate tool.
11. **DON'T OVERREACH.** Keep proper footing and balance at all times.
12. **MAINTAIN TOOLS WITH CARE.** Keep tools sharp and clean for better and safer performance. Follow instructions for lubricating and changing accessories. Inspect tool cords periodically and if damaged, have repaired by authorized service facility. Inspect extension cords periodically and replace if damaged. Keep handles dry, clean, and free from oil and grease.
13. **DISCONNECT TOOLS.** When not in use, before servicing, and when changing accessories, such as blades, bits, cutters.

14. **REMOVE ADJUSTING KEYS AND WRENCHES.** Form habit of checking to see that keys and adjusting wrenches are removed from tool before turning it on.
15. **AVOID UNINTENTIONAL STARTING.** Don't carry plugged-in tool with finger on switch. Be sure switch is OFF when plugging in.
16. **OUTDOOR USE EXTENSION CORDS.** When tool is used outdoors, use only extension cords intended for use outdoors and so marked.
17. **STAY ALERT.** Watch what you are doing, use common sense. Don't operate tool when you are tired.
18. **CHECK DAMAGED PARTS.** Before further use of the tool, a guard or other part that is damaged should be carefully checked to determine that it will operate properly and perform its intended function. Check for alignment of moving parts, binding of moving parts, breakage of parts, mounting, and any other conditions that may affect its operation. A guard or other part that is damaged should be properly repaired or replaced by an authorized service center unless otherwise indicated elsewhere in this instruction manual. Have defective switches replaced by authorized service center. Don't use tool if switch does not turn it on and off.
19. **GUARD AGAINST ELECTRIC SHOCK.** Prevent body contact with grounded surfaces. For example; pipes, radiators, ranges, refrigerator enclosures.
20. **REPLACEMENT PARTS.** When servicing, use only identical replacement parts.
21. **POLARIZED PLUGS.** To reduce the risk of electric shock, this equipment has a polarized plug (one blade is wider than the other). This plug will fit in a polarized outlet only one way. If the plug does not fit fully in the outlet, reverse the plug. If it still does not fit, contact a qualified electrician to install the proper outlet. Do not change the plug in any way.

VOLTAGE WARNING: Before connecting the tool to a power source (receptacle, outlet, etc.) be sure the voltage supplied is the same as that specified on the nameplate of the tool. A power source with voltage greater than that specified for the tool can result in **SERIOUS INJURY** to the user — as well as damage to the tool. If in doubt, **DO NOT PLUG IN THE TOOL.** Using a power source with voltage less than the nameplate rating is harmful to the motor.

ADDITIONAL SAFETY RULES

- 1. Handle the bits very carefully.**
- 2. Check the bit carefully for cracks or damage before operation. Replace cracked or damaged bit immediately.**
- 3. Avoid cutting nails. Inspect for and remove all nails from the workpiece before operation.**
- 4. Hold the tool firmly with both hands.**
- 5. Keep hands away from rotating parts.**
- 6. Make sure the bit is not contacting the workpiece before the switch is turned on.**
- 7. Before using the tool on an actual workpiece, let it run for a while. Watch for vibration or wobbling that could indicate improperly installed bit.**
- 8. Be careful of the bit rotating direction and the feed direction. (cf. P. 7)**
- 9. Do not leave the tool running. Operate the tool only when hand-held.**
- 10. Always switch off and wait for the bit to come to a complete stop before removing the tool from workpiece.**
- 11. Do not touch the bit immediately after operation; it may be extremely hot and could burn your skin.**
- 12. Keep the bit retracted so as not to protrude from the tool base except during actual operation.**

SAVE THESE INSTRUCTIONS.

Installing or removing router bit

CAUTION:

Always be sure that the tool is switched off and unplugged before installing or removing the bit.

Insert the bit all the way into the collet cone and tighten the collet nut securely with the two wrenches.

To remove the bit, follow the installation procedure in reverse.

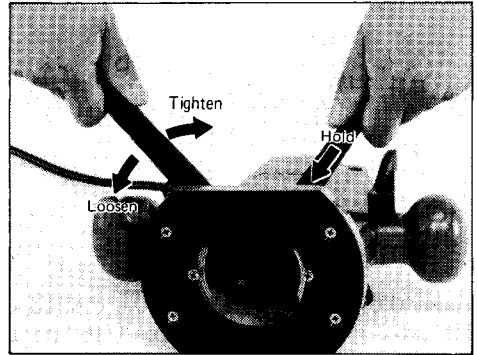

CAUTION:

Do not tighten the collet nut without inserting a bit, or the collet cone will break.

Adjusting depth of cut

Place the tool on a flat surface. Loosen the screw securing the stopper pole.

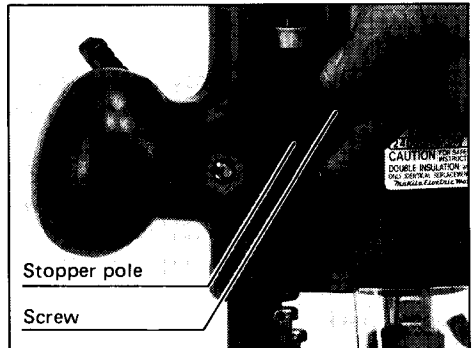

Loosen the lock lever and lower the tool body until the bit just touches the flat surface. Tighten the lock lever to lock the tool body.

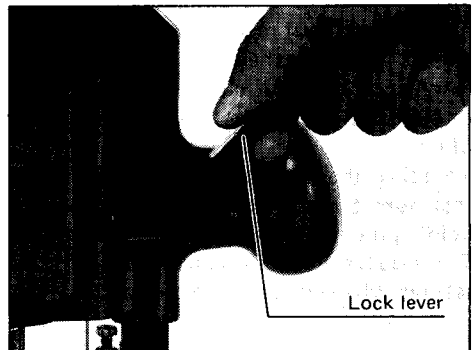

Next, lower the stopper pole until it makes contact with the adjusting hex bolt. Align the depth pointer with the "0" graduation.

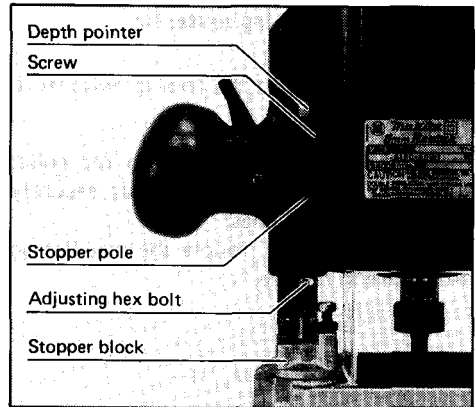

Raise the stopper pole until the desired depth of cut is obtained. The depth of cut is indicated on the scale (1 mm or 1/16" per graduation) by the depth pointer. Then tighten the screw to secure the stopper pole.

Now, your predetermined depth of cut can be obtained by loosening the lock lever and then lowering the tool body until the stopper pole makes contact with the adjusting hex bolt.

CAUTION:

Since excessive cutting may cause overload of the motor or difficulty in controlling the tool, the depth of cut should not be more than (5/8") at a pass when cutting grooves with a (1/4") diameter bit.

[Note: When cutting grooves with an (3/4") diameter bit, the depth of cut should not be more than (1/4") at a pass.] When you wish to cut grooves more than (5/8") deep with a (1/4") diameter bit or more than (1/4") deep with an (3/4") diameter bit, make several passes with progressively deeper bit settings.

Stopper block

The stopper block has three adjusting hex bolts which raise or lower 0.8 mm (about 1/32") per turn. You can easily obtain three different depths of cut using these adjusting hex bolts without readjusting the stopper pole.

Adjust the lowest hex bolt to obtain the deepest depth of cut, following the method of "Adjusting depth of cut". Adjust the two remaining hex bolts to obtain shallower depths of cut. The differences in height of these hex bolts are equal to the differences in depths of cut.

To adjust the hex bolts, first loosen the hex nuts on the hex bolts with the wrench and then turn the hex bolts. After obtaining the desired position, tighten the hex nuts while holding the hex bolts in the desired position.

The stopper block is also convenient for making three passes with progressively deeper bit settings when cutting deep grooves.

Adjusting lock lever

The locked position of the lock lever is adjustable. To adjust it, loosen the lock lever 3/4 turn and press the center of the lock lever. The hex nut will come out. Set the hex nut to the desired position and tighten the lock lever.

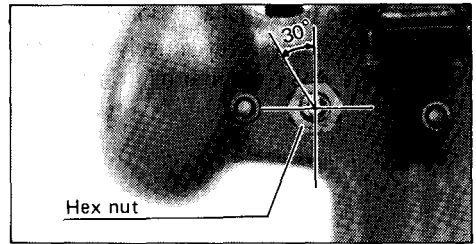

Switch action

To start the tool, simply pull the trigger. Release the trigger to stop.

CAUTION:

Before plugging in the tool, always check to see that the trigger switch actuates properly and returns to the "OFF" position when released.

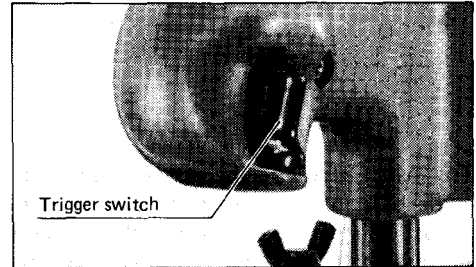

Operation

- Set the tool base on the workpiece to be cut without the bit making any contact. Then turn the tool on and wait until the bit attains full speed. Lower the tool body and move the tool forward over the workpiece surface, keeping the tool base flush and advancing smoothly until the cutting is complete.
- When doing edge cutting, the workpiece surface should be on the left side of the bit in the feed direction. (See the figure below)

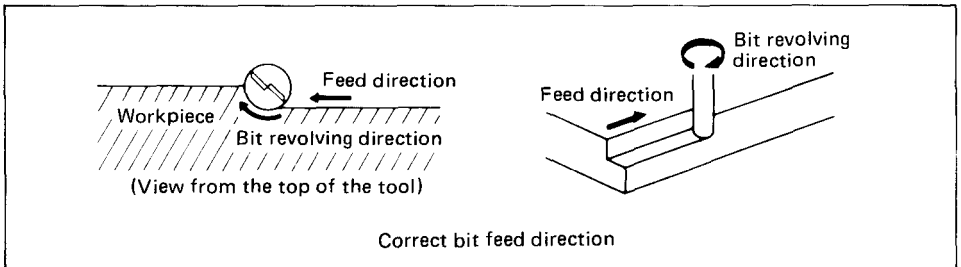

NOTE:

- Moving the tool forward too fast may cause a poor quality of cut, or damage to the bit or motor. Moving the tool forward too slowly may burn and mar the cut. The proper feed rate will depend on the bit size, the kind of workpiece and depth of cut. Before beginning the cut on the actual workpiece, it is advisable to make a sample cut on a piece of scrap lumber. This will show exactly how the cut will look as well as enable you to check dimensions.
- When using the straight guide, be sure to install it on the right side in the feed direction. This will help to keep it flush with the side of the workpiece.

Straight guide (optional accessory)

The straight guide is effectively used for straight cuts when chamfering or grooving.

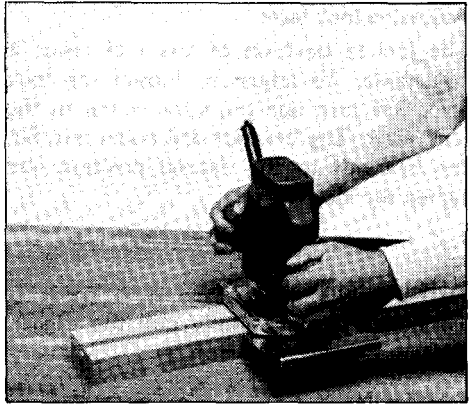

To install the straight guide, insert the guide bars into the holes in the tool base. Adjust the distance between the bit and the straight guide. At the desired distance, tighten the wing bolts to secure the straight guide in place.

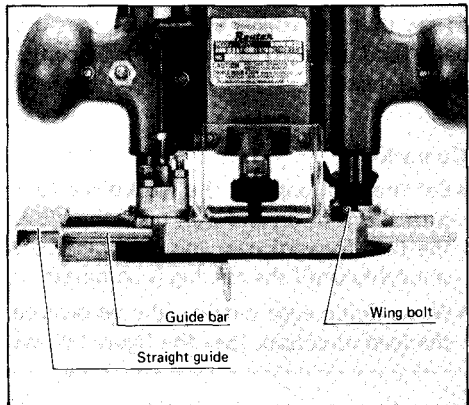

When cutting, move the tool with the straight guide flush with the side of the workpiece.

If the distance (A) between the side of the workpiece and the cutting position is too wide for the straight guide, or if the side of the workpiece is not straight, the straight guide cannot be used. In this case, firmly clamp a straight board to the workpiece and use it as a guide against the router base. Feed the tool in the direction of the arrow.

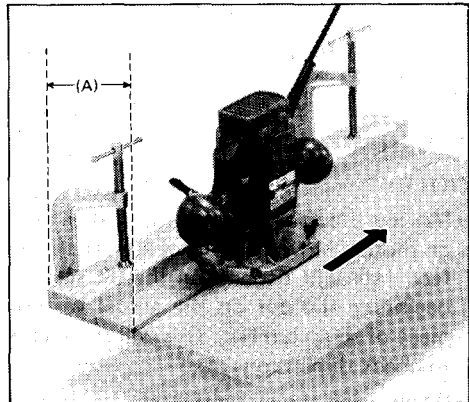

Templet guide (optional accessory)

The templet guide provides a sleeve through which the bit passes, allowing use of the router with templet patterns.

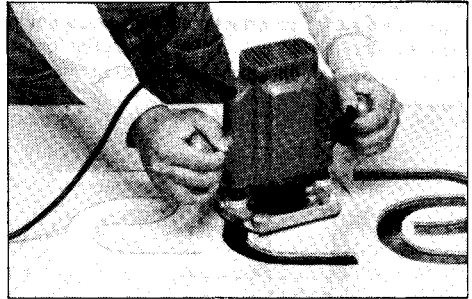

To install the templet guide, loosen the screws on the tool base, insert the templet guide and then tighten the screws.

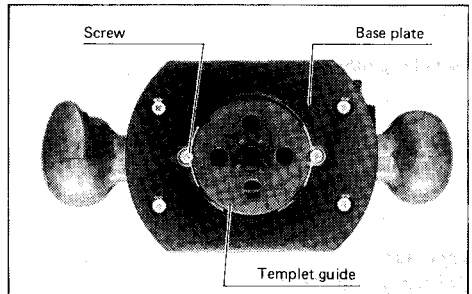

Secure the templet to the workpiece. Place the tool on the templet and move the tool with the templet guide sliding along the side of the templet.

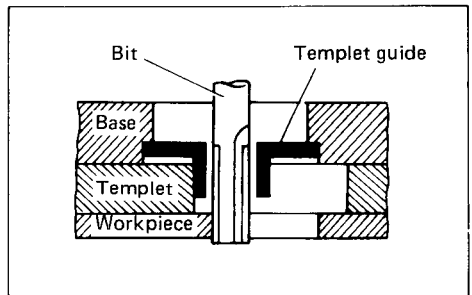

MAINTENANCE

CAUTION:

Always be sure that the tool is switched off and unplugged before attempting to perform inspection or maintenance.

To maintain product SAFETY and RELIABILITY, repairs, carbon brush inspection and replacement, any other maintenance or adjustment should be performed by Makita Authorized or Factory Service Centers, always using Makita replacement parts.

ACCESSORIES

CAUTION:

These accessories or attachments are recommended for use with your Makita tool specified in this manual. The use of any other accessories or attachments might present a risk of injury to persons. The accessories or attachments should be used only in the proper and intended manner.

Templet guide

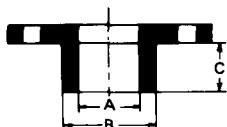

(mm)				
Part No.	Templet guide	A	B	C
164379-4	10	7.7 (19/64")	9.5 (3/8")	11.5 (29/64")
164775-6	11	9 (23/64")	11 (7/16")	13 (33/64")
164776-4	13	11 (7/16")	12.7 (1/2")	13 (33/64")
164835-4	16	14.5 (37/64")	16 (5/8")	13 (33/64")
164393-0	20	18 (45/64")	20 (25/32")	13 (33/64")
164470-8	27	24 (15/16")	27 (1-1/16")	13 (33/64")
163080-8	29	25 (63/64")	29 (1-9/64")	15 (19/32")
164471-6	30	27 (1-1/16")	30 (1-3/16")	13 (33/64")
164472-4	40	37 (1-29/64")	40 (1-37/64")	11.5 (29/64")

Templet guide 25

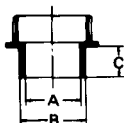

(mm)				
Part No.	Templet guide	A	B	C
321812-1	25	22.6 (57/64")	25.4 (1")	11 (7/16")

Lock nut

(for templet guide 25)

Part No. 252627-4

Templet guide adapter

(for templet guide 25)



(mm)				
Part No.	A	B	C	
321492-3	30 (1-3/16")	35 (1-3/8")	7 (9/32")	

Straight guide

Part No. 164834-6

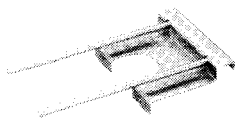

Wrench 22

Part No. 781011-1



Wrench 13

Part No. 781006-4



Collet cone

Size: 1/4"

Part No. 763637-1



Wrench 8

Part No. 781213-9



Trimmer guide assembly

Part No. 122385-5



Bits

STRAIGHT – Single Flute

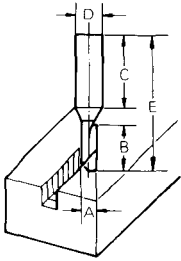

HIGH SPEED STEEL

PART NO.	A	B	C	D	E
733232-6A	1/8	5/16	1-1/8	1/4	1-5/8

STRAIGHT – 2 Flute

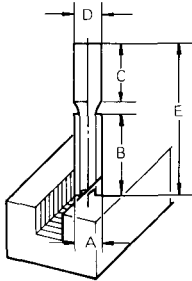

CARBIDE TIPPED

PART NO.	A	B	C	D	E
733003-2A	3/16	7/16	1-3/8	1/4	2
733003-4A	1/4	3/4	1-3/16	1/4	2-1/8
733003-8A	5/16	1	1-1/8	1/4	2-3/16

HIGH SPEED STEEL (STRAIGHT – 2 Flute)

PART NO.	A	B	C	D	E
733233-4A	5/16	7/8	1-3/16	1/4	2-1/8
733234-2A	1/2	7/8	1-1/8	1/4	2-1/8

HINGE MORTISING

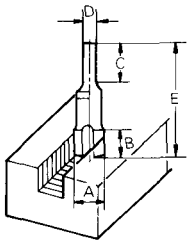

CARBIDE TIPPED

PART NO.	A	B	C	D	E
733006-9A	1/2	1/2	1-1/16	1/4	1-13/16

HIGH SPEED STEEL

PART NO.	A	B	C	D	E
733235-0A	1/2	1/2	3/4	1/4	1-15/16

VEINING – Single Flute

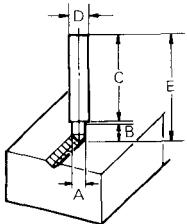

SOLID CARBIDE

PART NO.	A	B	C	D	E
733007-8A	3/16	7/32	1-1/4	1/4	1-1/2

ROUND NOSE

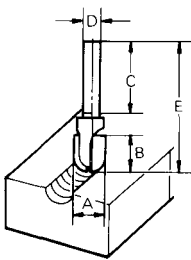

CARBIDE TIPPED

PART NO.	A	B	C	D	E
733008-2A	1/4	15/32	1-1/4	1/4	1-7/8
733008-4A	3/8	9/16	1-1/4	1/4	2
733008-6A	1/2	11/16	1-1/4	1/4	2-3/16
733008-8A	5/8	11/16	1-1/4	1/4	2-1/4
733009-0A	3/4	13/16	1-1/4	1/4	2-3/8

CORE BOX

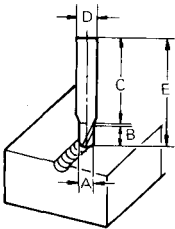

HIGH SPEED STEEL

PART NO.	A	B	C	D	E
733238-2A	1/4	1/4	1-3/16	1/4	1-1/2

VEE GROOVING

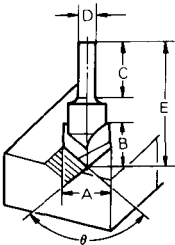

CARBIDE TIPPED

PART NO.	A	B	C	D	E	θ
733009-2A	3/8	1/2	1-3/16	1/4	2	90°
733009-4A	5/8	3/4	15/16	1/4	2	90°

14° DOVETAIL

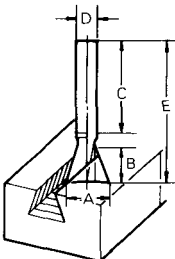

CARBIDE TIPPED

PART NO.	A	B	C	D	E
733009-6A	1/2	1/2	1-1/4	1/4	1-7/8

HIGH SPEED STEEL

PART NO.	A	B	C	D	E
733239-6A	1/2	1/2	1-3/8	1/4	2

PANEL PILOT

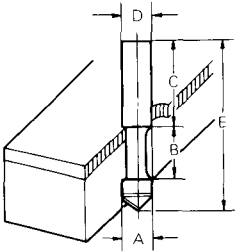

HIGH SPEED STEEL

PART NO.	A	B	C	D	E
733236-0A	1/4	3/4	1	1/4	2-7/16

CORNER ROUNDING

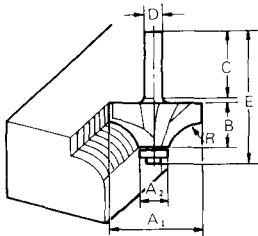

CARBIDE TIPPED -- Ball Bearing Pilot

PART NO.	A ₁	A ₂	B	C	D	E	R
733120-0A	7/8	1/2	3/8	1-1/4	1/4	1-15/16	3/16
733120-2A	1	1/2	1/2	1-1/4	1/4	2	1/4
733120-4A	1-1/8	1/2	1/2	1-1/4	1/4	2-1/16	5/16
733120-6A	1-1/4	1/2	5/8	1-1/4	1/4	2-1/8	3/8
733120-8A	1-1/2	1/2	3/4	1-1/4	1/4	2-1/4	1/2

REPLACEMENT BEARING -- NO. 733132-4A

HIGH SPEED STEEL -- Solid Pilot

PART NO.	A ₁	A ₂	B	C	D	E	R
733240-2A	11/16	3/16	1/2	1	1/4	1-3/4	1/4
733240-6A	15/16	3/16	5/8	1	1/4	1-7/8	3/8

BEADING

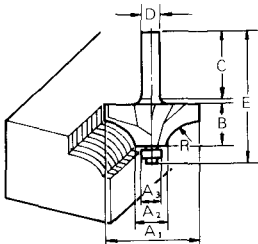

CARBIDE TIPPED -- Ball Bearing Pilot

PART NO.	A ₁	A ₂	A ₃	B	C	D	E	R
733121-4A	7/8	1/2	3/8	3/8	1-1/4	1/4	1-15/16	3/16
733121-6A	1	1/2	3/8	1/2	1-1/4	1/4	2	1/4
733121-8A	1-1/8	1/2	3/8	1/2	1-1/4	1/4	2-1/16	5/16
733122-0A	1-1/4	1/2	3/8	5/8	1-1/4	1/4	2-1/8	3/8
733122-2A	1-1/2	1/2	3/8	3/4	1-1/4	1/4	2-1/4	1/2

REPLACEMENT BEARING -- NO. 733132-2A

COVE

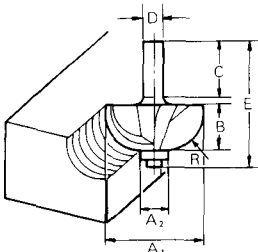

CARBIDE TIPPED -- Ball Bearing Pilot

PART NO.	A ₁	A ₂	B	C	D	E	R
733122-6A	7/8	3/8	3/8	1	1/4	1-5/8	1/4
733122-8A	1-1/8	3/8	1/2	1	1/4	1-3/4	3/8
733123-0A	1-3/8	3/8	5/8	1	1/4	1-7/8	1/2

REPLACEMENT BEARING -- NO. 733132-2A

HIGH SPEED STEEL -- Solid Pilot

PART NO.	A ₁	A ₂	B	C	D	E	R
733242-6A	11/16	3/16	1/2	1	1/4	1-3/4	1/4
733242-8A	15/16	3/16	3/4	1	1/4	2-1/32	3/8

45° CHAMFERING

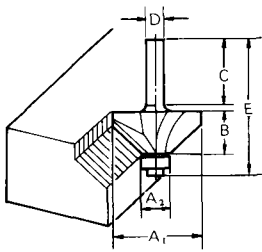

CARBIDE TIPPED – Ball Bearing Pilot

PART NO.	A ₁	A ₂	B	C	D	E
733124-4A	1-3/16	1/2	1/2	1-1/4	1/4	2-1/4
REPLACEMENT BEARING – NO. 733132-4A						

RABBETING

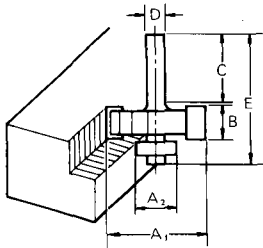

CARBIDE TIPPED – Ball Bearing Pilot

PART NO.	A ₁	A ₂	B	C	D	E
733124-2A	1-1/4	1/2	1/2	1-7/16	1/4	2-1/4
REPLACEMENT BEARING – NO. 733132-4A						

ROMAN OGEE

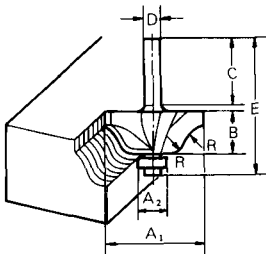

CARBIDE TIPPED – Ball Bearing Pilot

PART NO.	A ₁	A ₂	B	C	D	E	R
733123-2A	1	3/8	15/32	1-1/4	1/4	2	5/32
733123-4A	1-3/8	3/8	21/32	1-1/4	1/4	2-1/8	1/4
REPLACEMENT BEARING – NO. 733132-2A							

FLUSH TRIMMER – Self Piloting

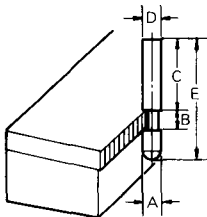

SOLID CARBIDE

PART NO.	A	B	C	D	E
733128-0A	1/4	1/4	1-1/16	1/4	1-9/16

7° BEVEL TRIMMER – Self-Piloting

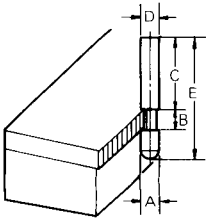

SOLID CARBIDE

PART NO.	A	B	C	D	E
733128-2A	3/16	1/4	1-1/16	1/4	1-9/16

2 FLUTE FLUSH TRIMMER

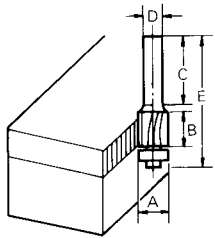

CARBIDE TIPPED

PART NO.	A	B	C	D	E
733128-8A	3/8	1	1-1/4	1/4	2-1/16
733128-9A	1/2	1/2	1-1/4	1/4	2-1/16
733129-0A	1/2	1	1-1/4	1/4	2-5/8

3/8" REPLACEMENT BEARING – NO. 733132-2A
1/2" REPLACEMENT BEARING – NO. 733132-4A

COMBINATION FLUSH/22° BEVEL TRIMMER

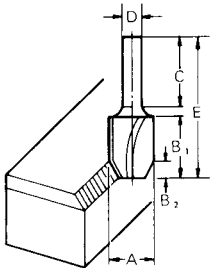

CARBIDE TIPPED

PART NO.	A	B ₁	B ₂	C	D	E
733128-6A	7/16	1/2	3/16	1-1/4	1/4	1-3/4

3 FLUTE FLUSH TRIMMER ASSEMBLY – Self-Piloting

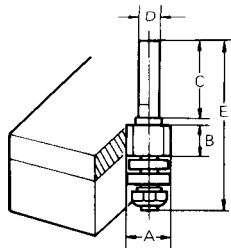

SOLID CARBIDE CUTTER

PART NO.	A	B	C	D	E
733129-2A	5/8	3/8	1-1/4	1/4	2-3/8

REPLACEMENT BEARING – NO. 733132-6A

3 FLUTE 22° BEVEL TRIMMER ASSEMBLY – Self-Piloting

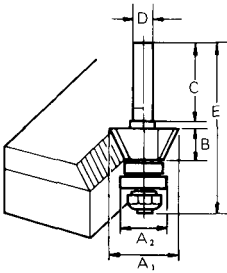

SOLID CARBIDE CUTTER

PART NO.	A ₁	A ₂	B	C	D	E
733129-4A	7/8	5/8	3/8	1-1/4	1/4	2-3/8
REPLACEMENT BEARING – NO. 733132-6A						

3 FLUTE FLUSH REPLACEMENT CUTTER

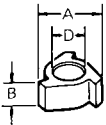

SOLID CARBIDE

PART NO.	A	B	D
733129-6A	5/8	3/8	1/4
FOR FLUSH TRIMMER ASSEMBLY NO. 733129-2A			

3 FLUTE 22° BEVEL REPLACEMENT CUTTER

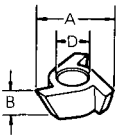

SOLID CARBIDE

PART NO.	A	B	D
733129-8A	7/8	3/8	1/4
FOR BEVEL TRIMMER ASSEMBLY NO. 733129-4A			

1/4" REPLACEMENT ARBOR

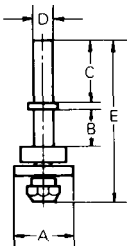

PART NO.	A	B	C	D	E
733131-2A	5/8	3/8	1-1/4	1/4	2-3/8
FOR FLUSH TRIMMER ASSEMBLY NO. 733129-2A AND NO. 733129-4A					

BALL BEARING PILOT

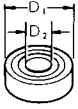

PART NO.	D_1	D_2
733132-2A	3/8 O.D.	1/8 I.D.
733132-4A	1/2 O.D.	3/16 I.D.
733132-6A	5/8 O.D.	1/4 I.D.

ROUTER

Model 3620

Model 3620A

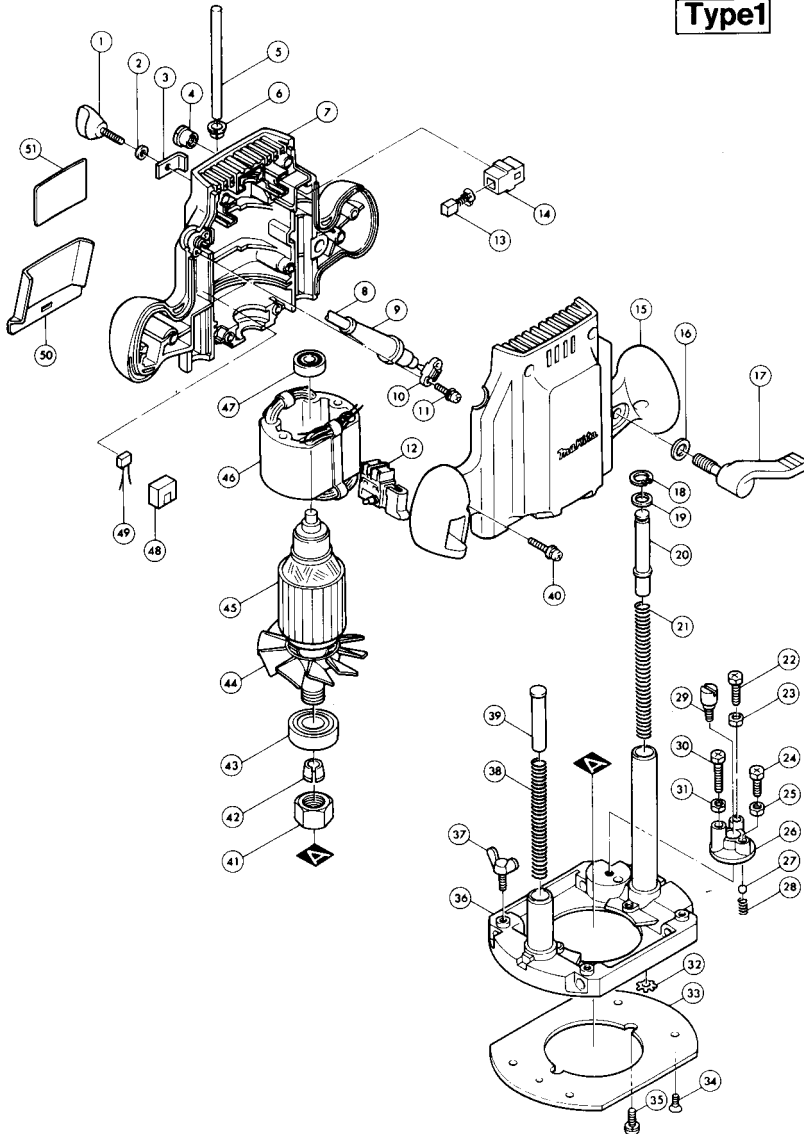
Type1

Note: The switch, noise suppressor and other part configurations may differ from country to country.

ITEM NO.	NO. USED	DESCRIPTION	ITEM NO.	NO. USED	DESCRIPTION
MACHINE			MACHINE		
1	1	Screw M5x20	27	1	Steel Ball 7.1
2	1	Flat Washer 5	28	1	Compression Spring 5
3	1	Pressure Plate	29	1	Flat Head Screw M6
4	1	Hex. Nut M8	30	1	Hex. Bolt M5x20
5	1	Stopper Pole	31	1	Hex. Nut M5
6	1	Depth Pointer	32	2	Self Lock 15
7	1	Housing Set (With Item 15)	33	1	Base Plate
8	1	Cord	34	4	Countersunk Head Screw M4x8
9	1	Cord Guard	35	2	Pan Head Screw M5x10 (With Washer)
10	1	Strain Relief	36	1	Base
11	2	Pan Head Screw M4x18 (With Washer)	37	2	Wing Bolt M5x15
12	1	Switch	38	1	Compression Spring 10
13	2	Carbon Brush	39	1	Pin 10
14	2	Brush Holder	40	7	Pan Head Screw M5x25 (With Washer)
15	1	Housing Set (With Item 7)	41	1	Collet Nut
16	1	Flat Washer 8	42	1	Collet Cone
17	1	Lever 45	43	1	Ball Bearing 6003DDW
18	1	Retaining Ring R-15	44	1	Fan 72
19	1	Flat Washer 10	45	1	ARMATURE ASSEMBLY (With Item 43 - 45 & 47)
20	1	Pin 10	46	1	FIELD ASSEMBLY
21	1	Compression Spring 10	47	1	Ball Bearing 608LLB
22	1	Hex. Bolt M5x28	50	1	Chip Deflector
23	1	Hex. Nut M5	51	1	Name Plate
24	1	Hex. Bolt M5x16			
25	1	Hex. Nut M5			
26	1	STOPPER ASSEMBLY (With Item 22 - 26 & 29 - 31)			

Note: The switch and other part specifications may differ from country to country.



MAKITA LIMITED ONE YEAR WARRANTY

Warranty Policy

Every Makita tool is thoroughly inspected and tested before leaving the factory. It is warranted to be free of defects from workmanship and materials for the period of ONE YEAR from the date of original purchase. Should any trouble develop during this one-year period, return the COMPLETE tool, freight prepaid, to one of Makita's Factory or Authorized Service Centers. If inspection shows the trouble is caused by defective workmanship or material, Makita will repair (or at our option, replace) without charge.

This Warranty does not apply where:

- repairs have been made or attempted by others;
- repairs are required because of normal wear and tear;
- The tool has been abused, misused or improperly maintained;
- alterations have been made to the tool.

IN NO EVENT SHALL MAKITA BE LIABLE FOR ANY INDIRECT, INCIDENTAL OR CONSEQUENTIAL DAMAGES FROM THE SALE OR USE OF THE PRODUCT. THIS DISCLAIMER APPLIES BOTH DURING AND AFTER THE TERM OF THIS WARRANTY.

MAKITA DISCLAIMS LIABILITY FOR ANY IMPLIED WARRANTIES, INCLUDING IMPLIED WARRANTIES OF "MERCHANTABILITY" AND "FITNESS FOR A SPECIFIC PURPOSE," AFTER THE ONE-YEAR TERM OF THIS WARRANTY.

This Warranty gives you specific legal rights, and you may also have other rights which vary from state to state. Some states do not allow the exclusion or limitation of incidental or consequential damages, so the above limitation or exclusion may not apply to you. Some states do not allow limitation on how long an implied warranty lasts, so the above limitation may not apply to you.

Makita Corporation

3-11-8, Sumiyoshi-cho,
Anjo, Aichi 446 Japan

883585F061

PRINTED IN JAPAN

1992 — 8 — N

Free Manuals Download Website

<http://myh66.com>

<http://usermanuals.us>

<http://www.somanuals.com>

<http://www.4manuals.cc>

<http://www.manual-lib.com>

<http://www.404manual.com>

<http://www.luxmanual.com>

<http://aubethermostatmanual.com>

Golf course search by state

<http://golfingnear.com>

Email search by domain

<http://emailbydomain.com>

Auto manuals search

<http://auto.somanuals.com>

TV manuals search

<http://tv.somanuals.com>