

TECHNICAL INFORMATION



NEW TOOL

P 1 / 30

Model No. ▶ LF1000

Description ▶ Flip Over Saw 260mm (10-1/4")

CONCEPT AND MAIN APPLICATIONS

Model LF1000 is the first flip over saw from Makita.
Miter saw and Table saw are combined for great versatility.

Its main advantages are;

- Weighs only 32kg (70lbs) for easy transport to job sites.
- Quick miter saw/table saw conversion
- Electronic with constant speed control and soft start
- Rigid cast aluminum table

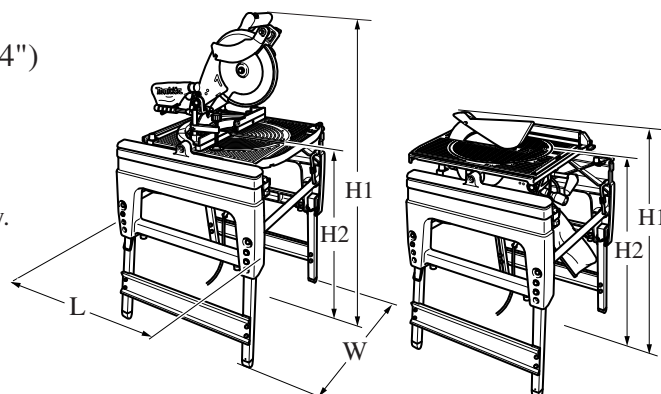

[in Miter Saw mode]

[in Table Saw mode]

Dimensions: mm (")		
	in Miter Saw mode	in Table Saw mode
Length (L)	660 (26)	660 (26)
Width (W)	650 (25-1/2)	650 (25-1/2)
Height	(H1)	1,220 (48)
	(H2)	800 (31-1/2)
		845 (33-1/4)

H1: to the table top, H2: to the tool head

Voltage (V)	Current (A)	Cycle (Hz)	Continuous Rating (W)		Max. Output (W)
			Input	Output	
110	15	50/ 60	1,650	900	2,200
220	8.5	50/ 60	1,650	900	2,200
230	8.4	50/ 60	1,650	900	2,200
240	8.3	50/ 60	1,650	900	2,200

► Specification

Saw blade	Type	TCT Saw blade			
	Diameter: mm (")	260 (10-1/4)			
	Hole diameter: mm (")	30 (1-3/16)			
Continuous rating input: W	High voltage	1,650 (230V)			
	Low voltage	1,650 (110V)			
No load speed: min-1= rpm		2,700			
Electronic feature	Soft start	Yes			
	Constant speed control	Yes			
Cutting capacity* (height x width): mm (") [Table saw: height only]	Cutting angle		Mode	Miter saw	Table saw
	0 degree				70 (2-3/4)
	45 degrees bevel				48 (1-7/8)
	Bevel angle	Miter angle			
	0 degree	0 degree	20 x 210 (13/16 x 8-1/4)	68 x 155 (2-11/16 x 6-1/8)	
45 degrees	0 degree	50 x 150 (2 x 5-7/8)			
Protection against electric shock		Double insulation			
Power supply cord: m (ft)		2.5 (8.2)			
Net weight: kg (lbs)		32 (70)			

*When cutting with 260mm diameter blade

▶ **Standard equipment**

TCT saw blade 1 pc	Angle rule ass'y 1 pc	Box wrench 13-3 1 pc	Triangular rule 1 pc
Vise ass'y 1 pc	Top cover ass'y 1 pc	Push stick 1 pc	
Dust bag ass'y 1 pc	Dust cover ass'y 1 pc	Fix plate 3 pcs	
Ruler ass'y 1 pc	Elbow 1 pc	Hex bolt M6x16 3 pcs	

Note: The standard equipment for the tool shown above may differ by country.

▶ **Optional accessories**

Assorted TCT saw blades

► Repair

CAUTION: Remove the saw blade from the machine for safety before repair/ maintenance !

[1] NECESSARY REPAIRING TOOLS

Code No.	Description	Use for
	Square	Assembling the legs of table
	No.3 Philips driver bit	Removing/tightening of M6x60 Pan head screws that secure Motor housing to Blade case.
1R003	Retaining ring S Pliers ST-2N	Removing Retaining ring from Safety cover
1R207	45 degree Set square	Setting the miter/bevel angle of saw blade to 45 degrees
1R208	90 degree Set square	Setting the miter/bevel angle of saw blade to 90 degrees
1R269	Bearing extractor	Removing Ball bearings
1R288	Screwdriver magnetizer	Removing Steel balls, etc.
1R230	1/4" Hex shank bit for M6	Disassembling Table
1R231	1/4" Hex shank bit for M8	Disassembling Frame
1R291	Retaining ring S and R pliers	Removing Retaining ring S-15 from Spindle
1R340	Wrench for bearing retainer	Removing/tightening Bearing retainer 25-36

[2] LUBRICATION

[2] -1. Saw Head Section

Apply Makita grease N. No.1 to the following portions designated with the black triangle to protect parts and product from unusual abrasion. **See Fig. 1.**

Item No.	Description	Portion to lubricate
50	Hex bolt M10	The surface that contacts Arm complete
61	Knob 40	The threaded portion
62	Steel ball 6	Whole surface
64	Sleeve 6	The surface that contacts Connecting rod
71	Sleeve 10	The surface that contacts Adjust nut
85	Flat washer 10	The surface that contacts Connecting rod
91	Sub arm	Three surfaces that contacts Arm complete
121	Blade case	The gear room (Put approx. 7g.) Two surfaces that contact Arm complete

Fig. 1

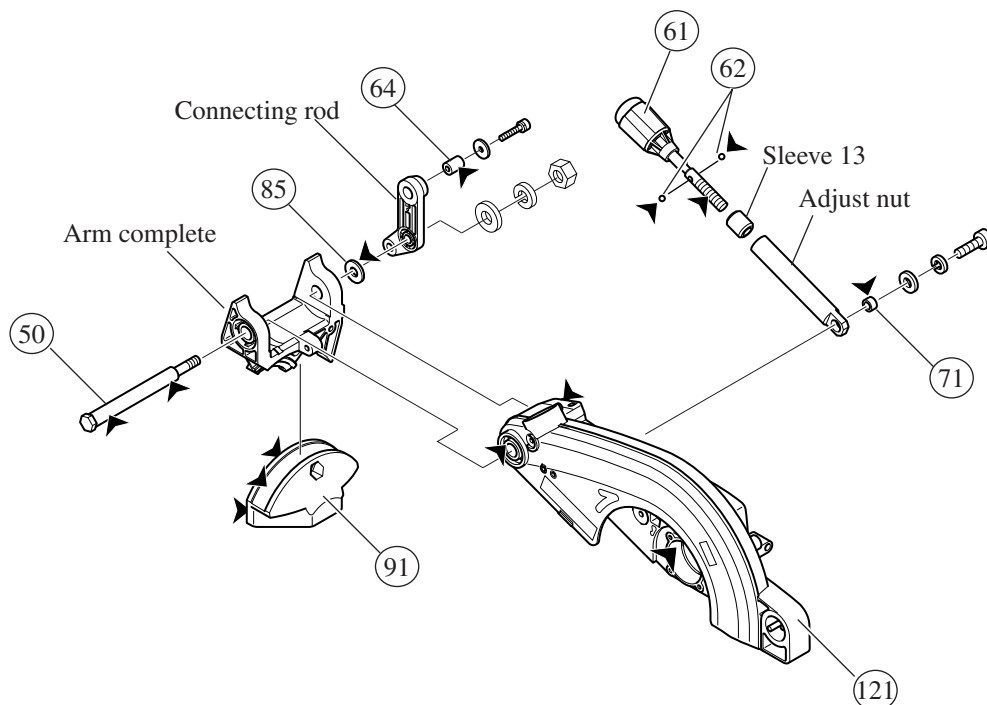

► Repair

[2] LUBRICATION (cont.)

[2] -2. Table Section

Apply Makita grease N. No.1 to the following portions designated with the black triangle to protect parts and product from unusual abrasion. See Fig.2.

Item No.	Description	Portion to lubricate
153	Guide fence	The both ends which contact Frame set.
228	Table complete	The surfaces that contact Slide plates and Turn table
260	Sleeve 8	The surface that contacts Frame set

Fig. 2

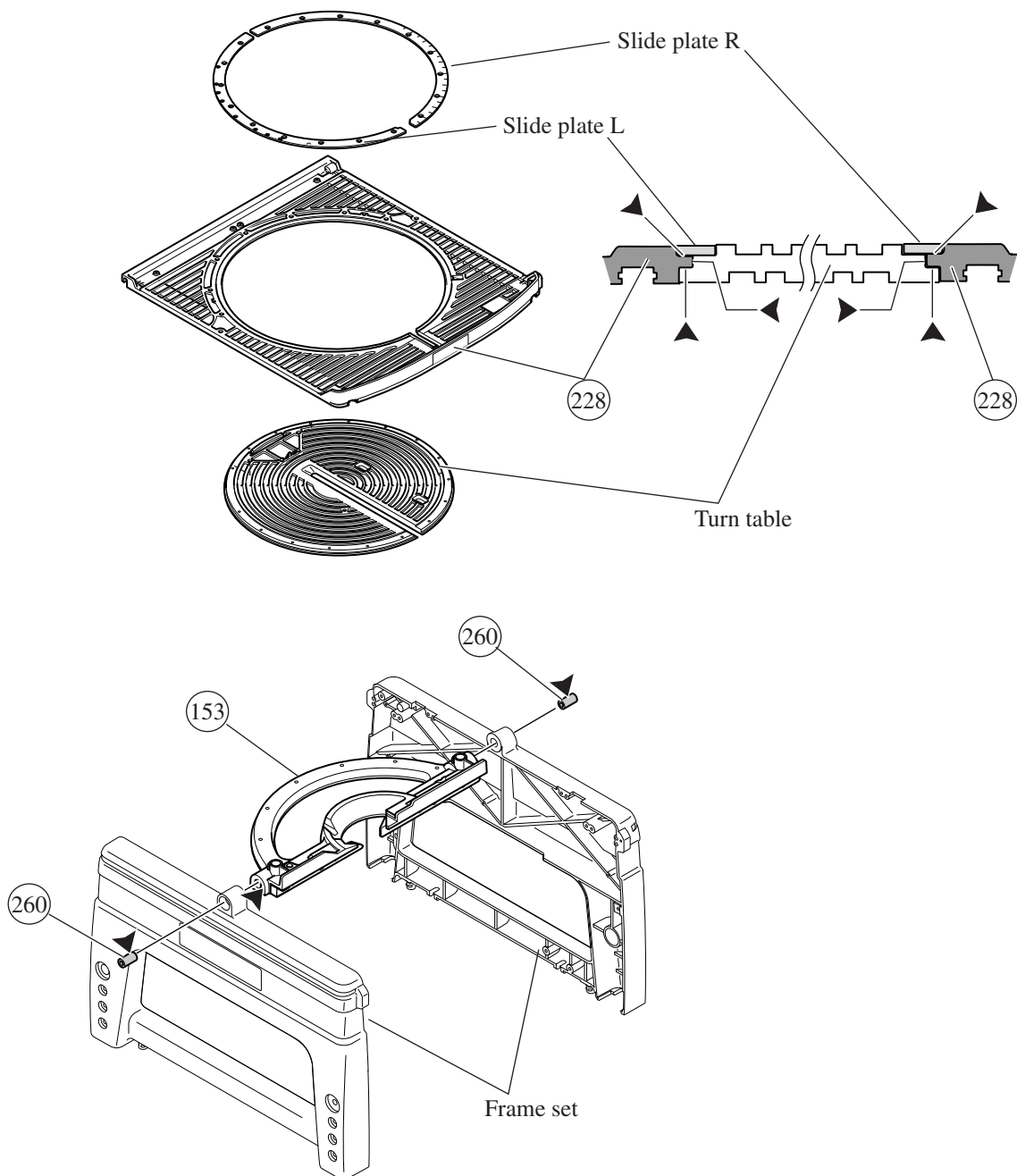

► Repair

[3] DISASSEMBLY/ASSEMBLY

[3] -1. Handle Section

DISASSEMBLING

The Handle section can be disassembled without separating Motor housing from Blade case.

Take the following steps:

- 1) Set the machine in the mode of miter saw. And lock the saw head unit at the lowest position by pushing Knob 20 as illustrated in **Fig. 3**.
- 2) Remove Handle cover by unscrewing two 4x25 Tapping screws and four 4x18 Tapping screws. (**Fig. 4**)
Now the inner parts of the Handle section can be replaced.

Note: Be careful not to lose Switch button (Lock off button) when removing Handle cover.

Fig. 3

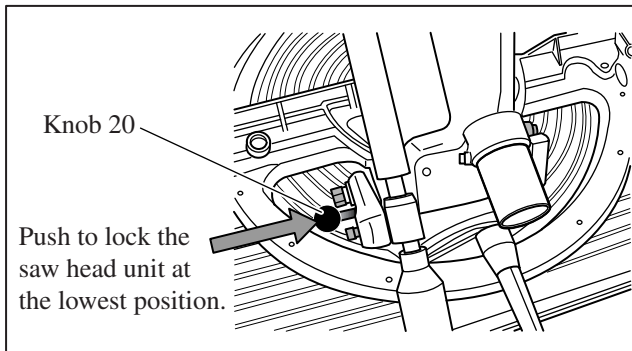
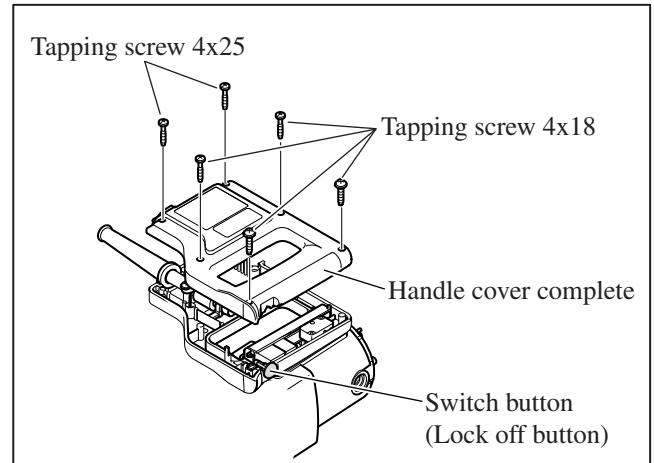

Fig. 4



ASSEMBLING

- 1) Assemble Now lock-off mechanism to Handle by mounting first Compression spring 4, then Lock-off lever and Switch button as illustrated in **Fig. 5**.

Note: Put Compression spring 4 securely in place. If not, the lock-off mechanism will not work properly.

- 2) Mount the inner parts (Switch, Brake switch, Line filter, etc). (**Fig. 6**)

Fig. 5

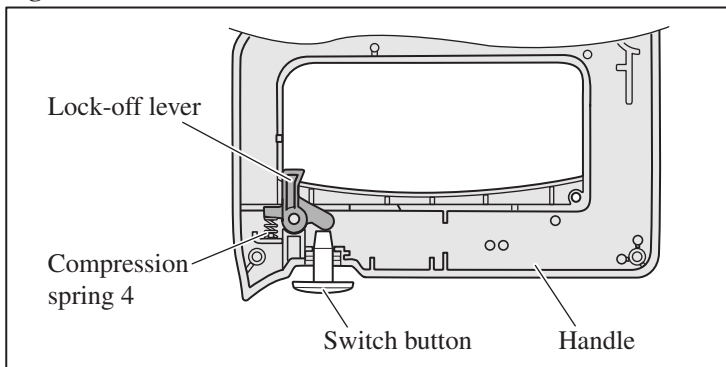
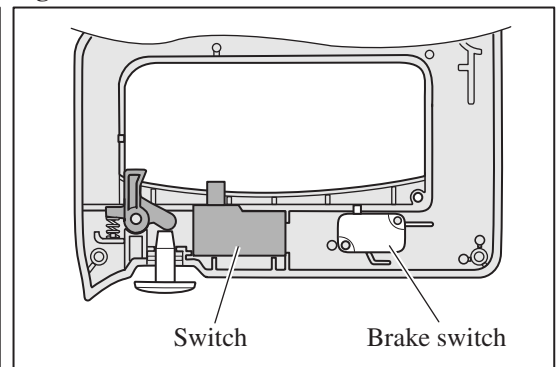
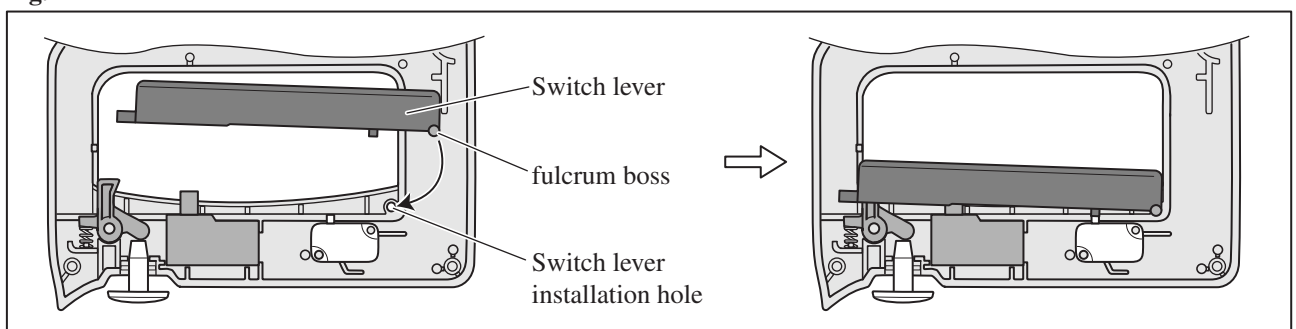

Fig. 6



- 3) Install Switch lever on Handle by fitting the fulcrum boss on Switch lever securely in the switch lever installation hole of Handle. (**Fig. 7**) And then do the reverse of disassembling steps.

Fig. 7



► **Repair**

[3] **DISASSEMBLY/ASSEMBLY**

[3] -2. **Switch Box (On/Off Switch Section)**

Switch box is located below Table on Frame complete. (Fig. 8)

Fig. 8

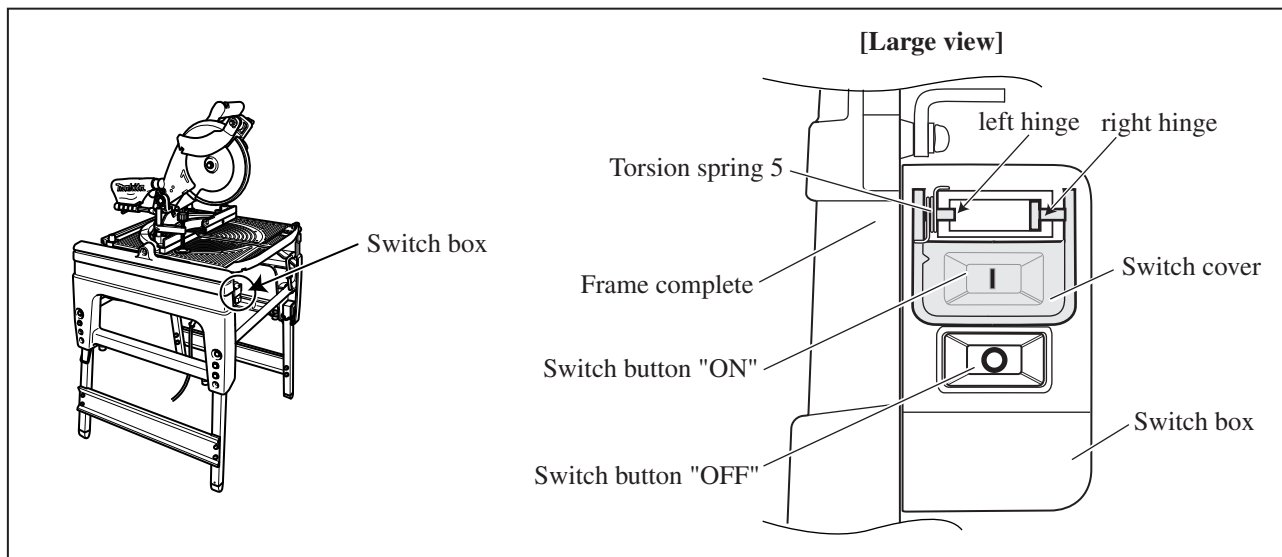

DISASSEMBLING

- 1) First, disconnect the right hinge of Switch cover from Switch box using slotted screwdriver. (Fig. 9)
- 2) Then, while lifting up the right hinge, pull off the left hinge from Switch cover. (Fig. 10)
- 3) Remove Torsion spring 5 from the left hinge.

Fig. 9

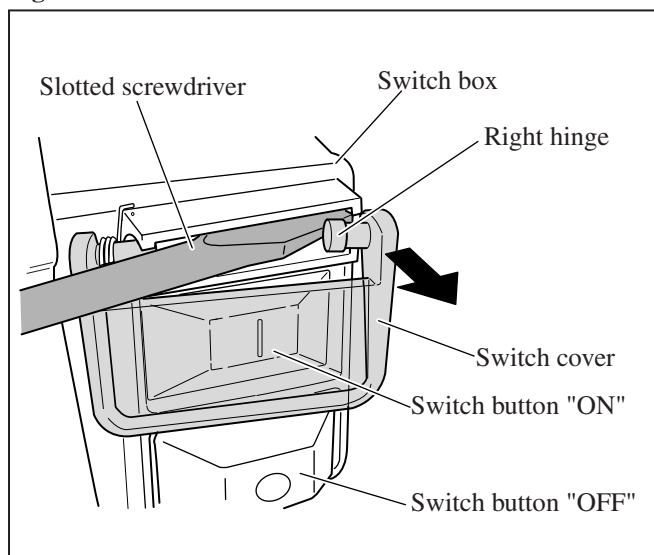
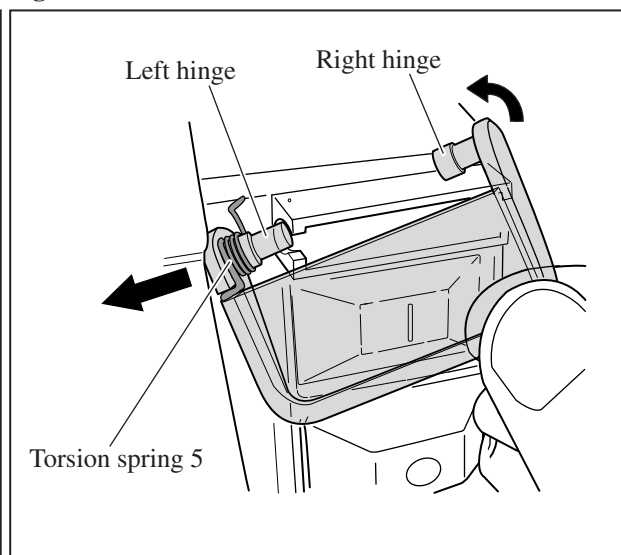

Fig. 10



ASSEMBLING

Do the reverse of the disassembling steps.

► Repair

[3] DISASSEMBLY/ASSEMBLY

[3] -3. Motor Housing

DISASSEMBLING

- 1) Remove Brush holder caps and Carbon brushes from Motor housing.
- 2) Remove four M6x60 Pan head screws using No.3 Phillips screwdriver. **(Fig. 11)**
Note: Motor housing can not be separated from Blade case in this step because Handle is interfered by Lock lever.
- 3) Turn Motor housing until handle is released from Lock lever. Then separate Motor housing from Blade case by pulling off. **(Fig. 12)** Now Armature can be replaced.
Note: Pull off Motor housing carefully so as to prevent Compression spring 9 of the shaft lock mechanism from popping out of place.

Fig. 11

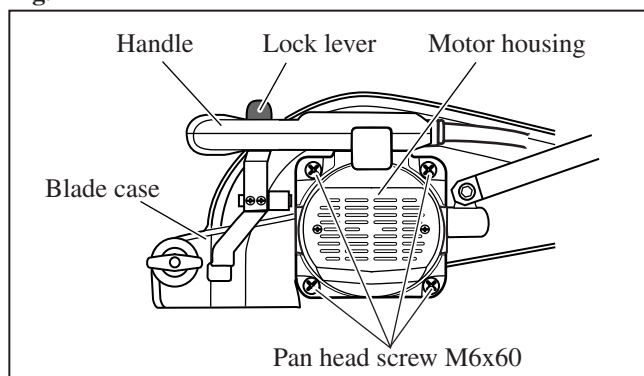
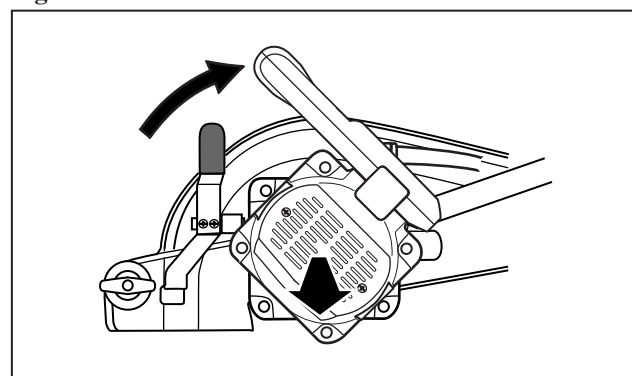
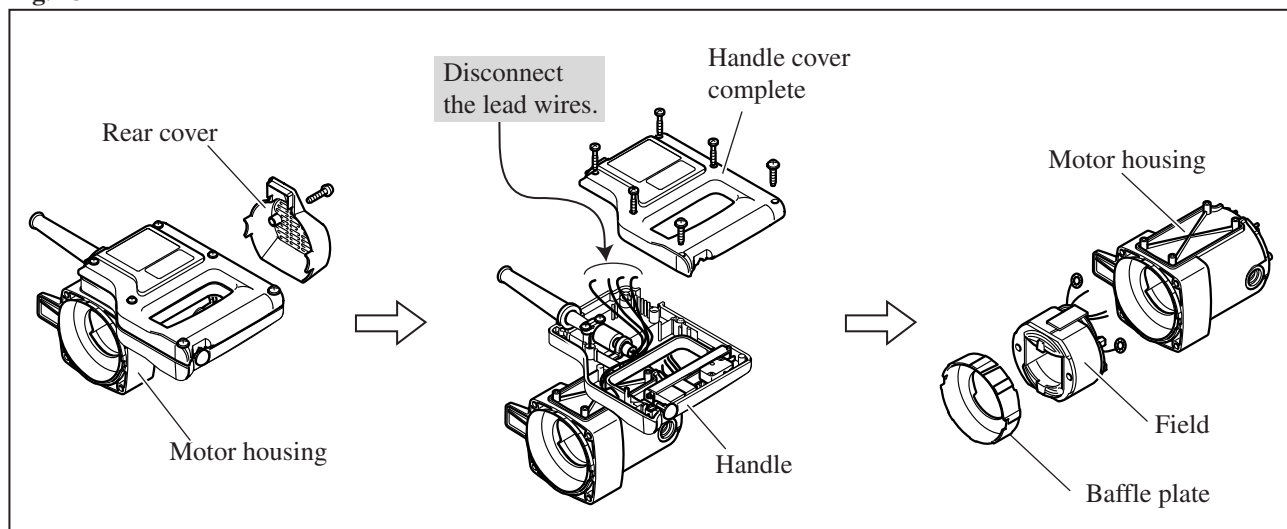

Fig. 12



- 4) When replacing Field, separate Motor housing first as described above.
- 5) Then remove Rear cover from Motor housing. Remove Handle cover complete from handle, and disconnect lead wires from Field. Now Motor housing can be separated from Handle. **(Fig. 13)**
- 6) After removing Baffle plate, remove Field by tapping the edge of Motor housing with plastic hammer. **(Fig. 13)**

Fig. 13



ASSEMBLING

Do the reverse of the disassembling steps.

► Repair

[3] DISASSEMBLY/ASSEMBLY

[3] -4. Gear Section

DISASSEMBLING

- 1) Disconnect Tension spring 4 from Blade case. By removing Retaining ring S-42 with Retaining pliers ST-2N (No.1R003), Safety cover can be separated from Blade case. (Fig. 14)
- 2) By unscrewing four M5x16 Countersunk head screws, the Gear section can be separated from Blade case. (Fig. 15)

Fig. 14

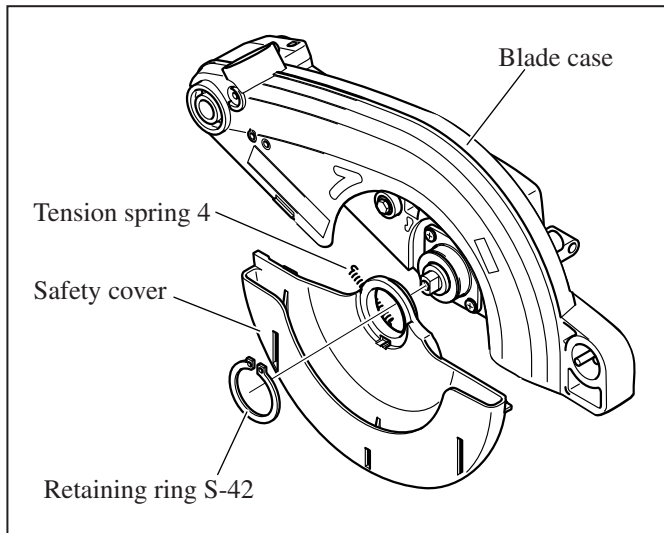
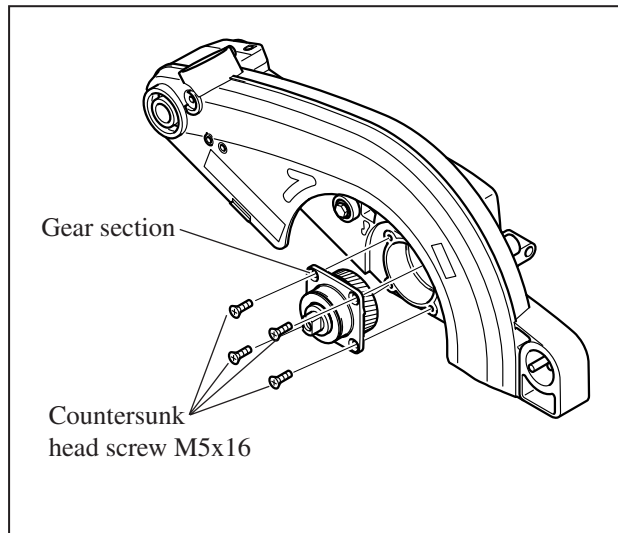
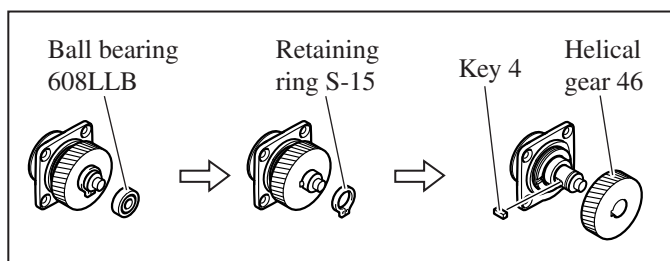

Fig. 15



- 3) Remove Ball bearing 608LLB from Spindle with Bearing extractor (No.1R269), then Retaining ring S-15 with Retaining Ring S and R Pliers (No.1R291). Now Helical gear 46 can be removed by hand. (Fig. 16)

Fig. 16



- 4) Fix Bearing box in vise.

Note: It is not necessary to remove Ring 15 in this step because it can be used as a guide for Wrench for Bearing Retainer (No.1R340) when removing Bearing retainer 25-36.

Set No.1R340 on Bearing retainer 25-36, and turn clockwise to remove Bearing retainer 25-36 from Bearing box. Then remove Ring 15 from Spindle. (Fig. 17)

- 5) When removing Spindle from Bearing box, press from the Flange installation side. (Fig. 18)

Fig. 17

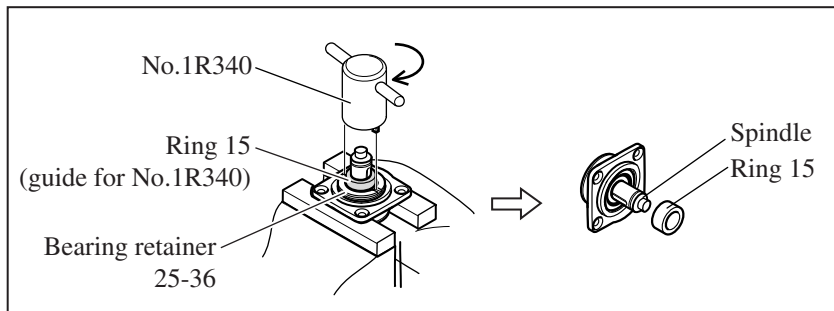
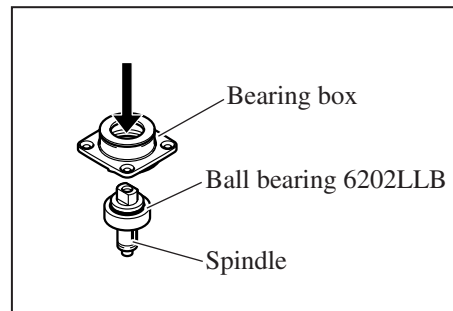

Fig. 18



ASSEMBLING

Do the reverse of the disassembling steps.

► **Repair**

[3] DISASSEMBLY/ASSEMBLY

[3] -5. Blade Case Section

DISASSEMBLING

- 1) Remove Safety cover as illustrated in **Fig. 14**.
- 2) Remove Dust nozzle. Then remove Hex socket head bolt M6x30 and Flat washer 6 for disconnecting the cutting depth adjusting mechanism and Connecting rod. (**Fig. 19**)
- 3) Loosen Hex nut M10 on Connecting rod. But do not remove from Connecting rod in this step. (**Fig. 19**)
- 4) Remove Hex socket head bolt M6x20, Flat washer 6 and Ring 6 for disconnecting the linkage of Link plate and Arm complete. (**Fig. 20**)
- 5) Remove Hex socket head bolt M5x20 and Sleeve 5 from Blade case with 1/4" Hex shank bit for M6 (No.1R230) while pressing down Blade case so that it is not raised by the force of Torsion spring 34. (**Fig. 20**)
- 6) Disconnect Connecting rod from Arm complete by removing Hex nut M10. (**Fig. 21**)
- 7) While holding Blade case as illustrated in **Fig. 22**, remove Hex bolt M10 and Flat washer 16 from Arm complete. Now Blade case section with Torsion spring 34 and Sleeve 17 (2pcs) can be separated from Arm complete.

Fig. 19

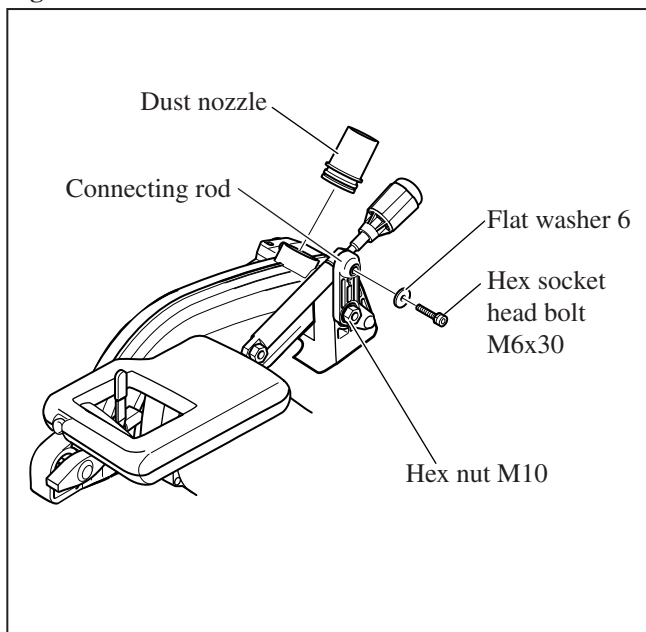

Fig. 20

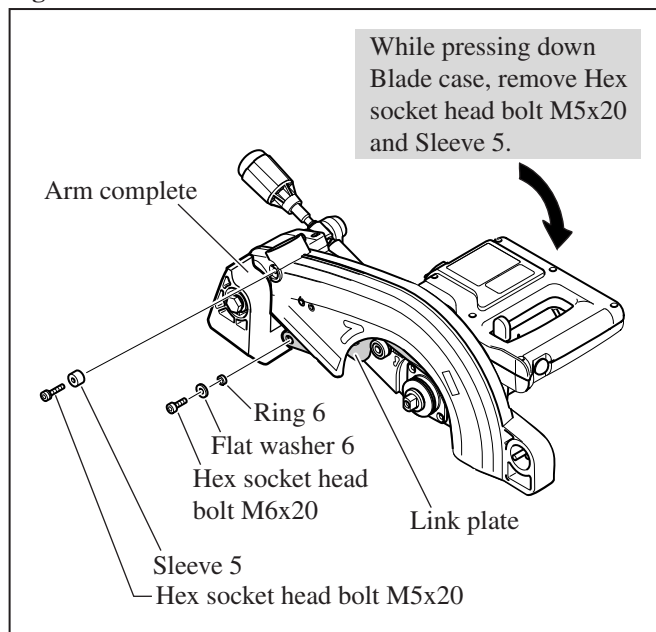

Fig. 21

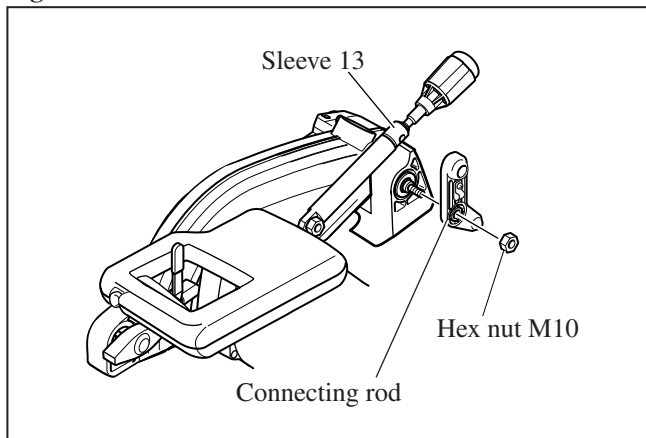
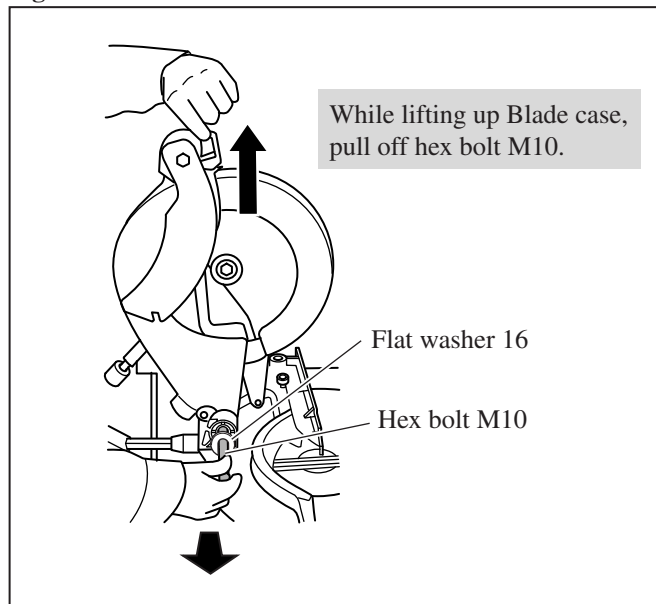

Fig. 22



► Repair

[3] DISASSEMBLY/ASSEMBLY

[3] -5. Blade Case Section (cont.)

ASSEMBLING

Do the reverse step of disassembling steps. Remember the following notes.

1. When installing Sleeve 13 and Connecting rod on Knob 40;

Slide Sleeve 13 as far as possible toward Steel ball 6. At this time, the distance between Sleeve 13 and the neck of Knob 40 will be about 7mm. While keeping the distance, secure Connecting rod to Sleeve 13 with Hex socket head bolt M6x30. (Fig. 23)

Fig. 23

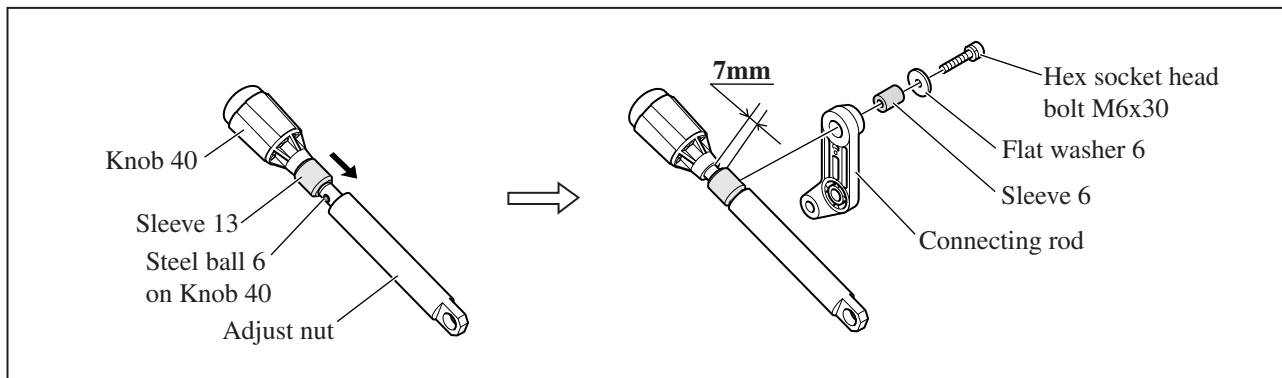

2. When installing Link plate and Safety cover on Blade case;

As illustrated in Fig. 24, put Link plate on Ball bearing 608LLB that is mounted to the inside wall of Blade case for smooth action of Link plate. Then secure Link plate to Arm complete with Hex socket head bolt M6x20. (Fig. 20)

On the back of Safety cover, there is a rib that acts as a guide rail for the Ball bearing on Link plate.

Mount Safety cover to Bearing box so that the Ball bearing of Link plate fits on the rib. (Fig. 25)

And secure Safety cover with Retaining ring S-42. (Fig. 14)

Fig. 24

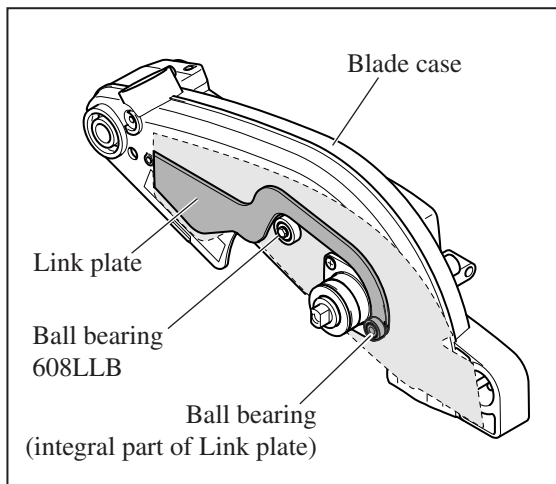
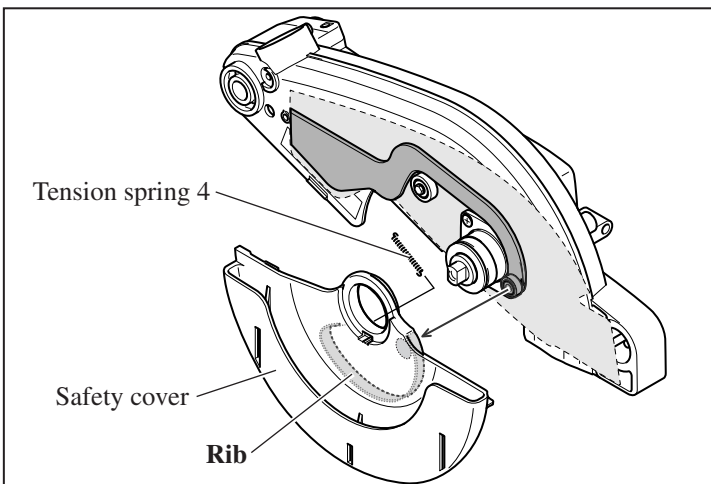
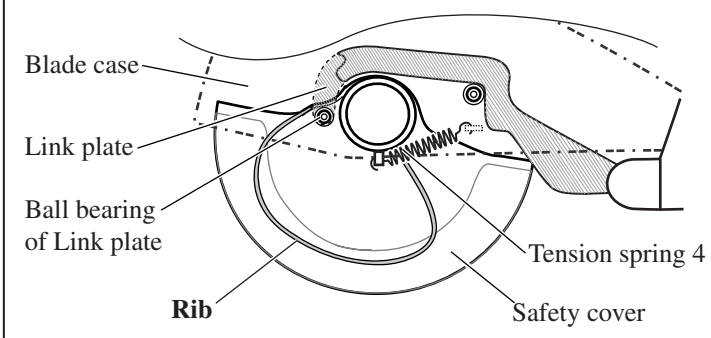

Fig. 25



Safety cover and Link plate correctly set in place, viewed from the Motor housing side



► Repair

[3] DISASSEMBLY/ASSEMBLY

[3] -6. Riving Knife

DISASSEMBLING

- 1) First, fix riving knife as illustrated in **Fig. 26**.
- 2) Remove Stop ring E-4, then loosen Wing bolt M8. Now Riving knife can be removed. (**Fig. 27**)

Fig. 26

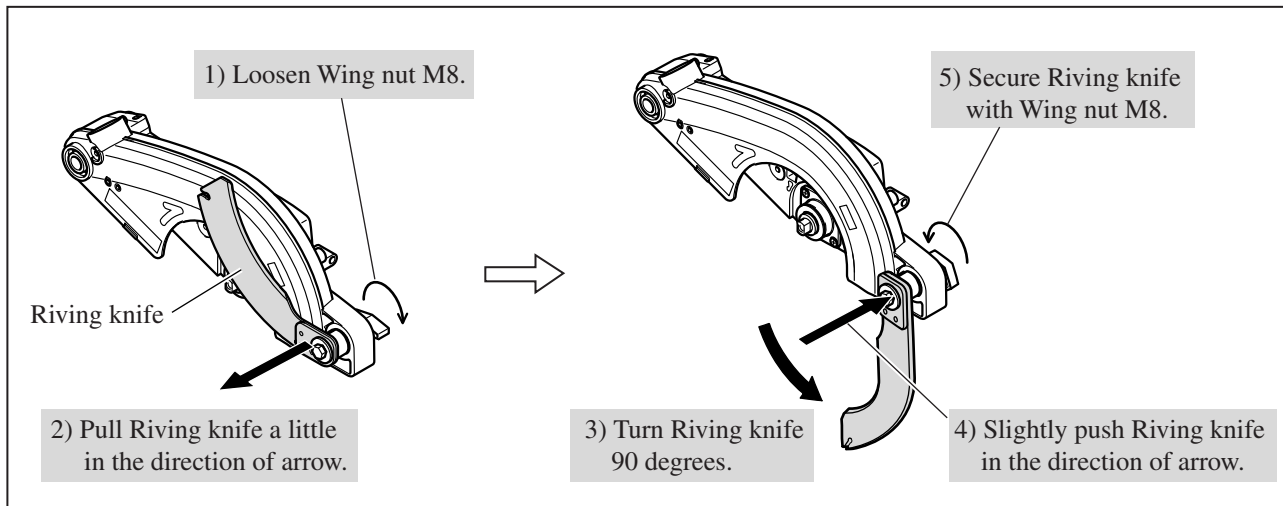
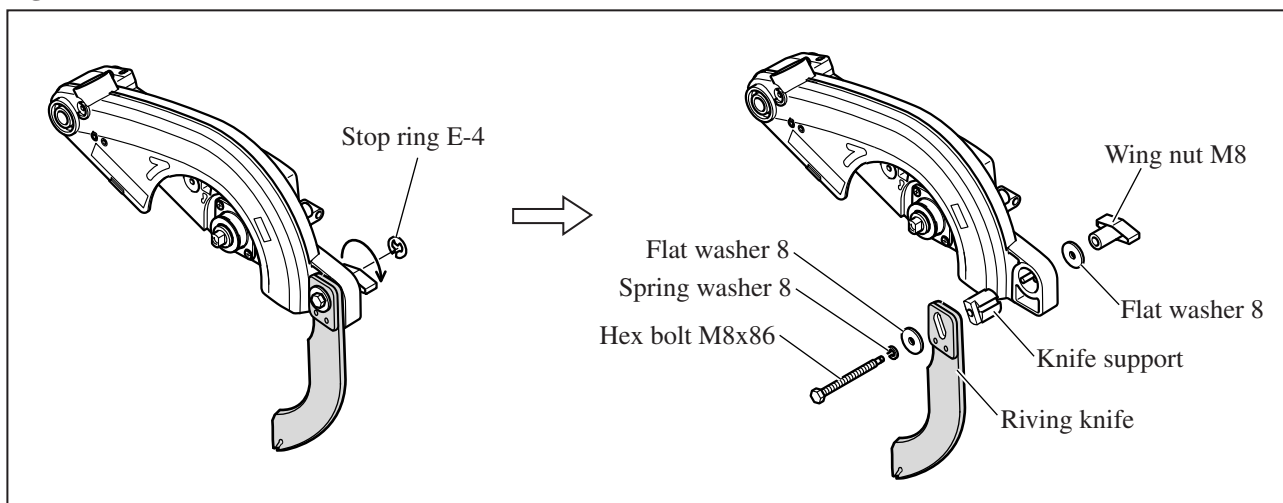

Fig. 27



ASSEMBLING

Do the reverse of the disassembling steps.

► Repair

[3] DISASSEMBLY/ASSEMBLY

[3] -7. Table Section

DISASSEMBLING

When disassembling the Table section, Arm complete has to be separated from Sub arm. However, it is not necessary to separate the Blade case section from Arm complete.

- 1) Remove Power supply cord from Strain relieves on Frame. However, it is not necessary to remove from the Strain relief on Connecting rod.
- 2) Remove Pan head screw M4x10 and Lever 100. After unscrewing Hex nut M10-17, remove Spacer and Thrust needle gauge 1022. (Fig. 28)
- 3) Unscrew Hex lock nut M10-17. Then remove Indication plate from Sub arm by unscrewing Pan head screw M4x10. (Fig. 29)
- 4) By removing Hex bolt M10, Arm complete can be separated from Sub arm. (Fig. 30)

Fig. 28

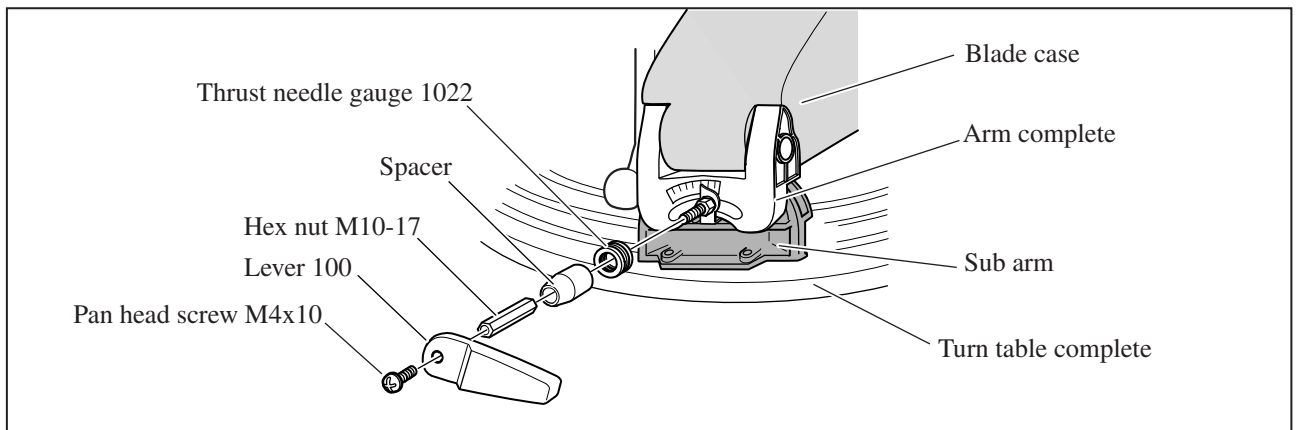

Fig. 29

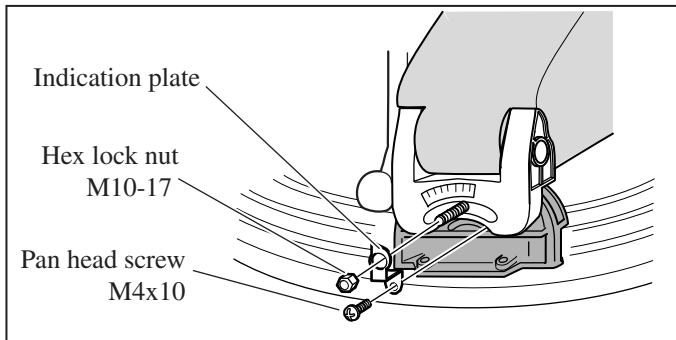
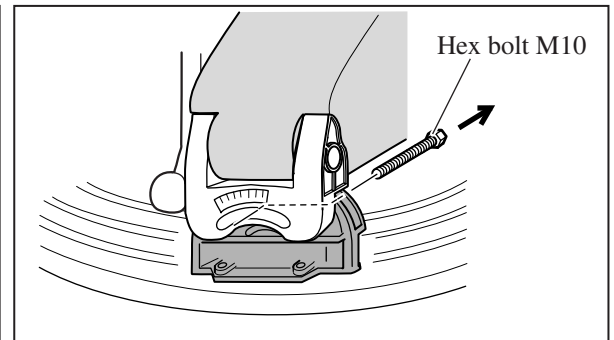
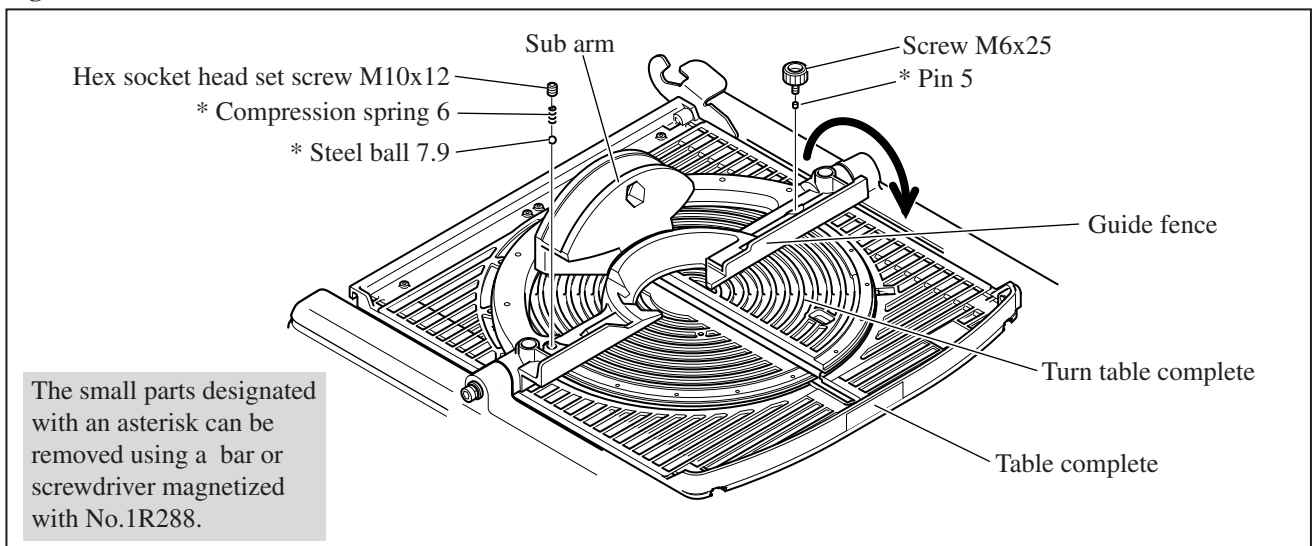

Fig. 30



- 5) Remove Screw M6x25 and Pin 5. And remove Hex socket head set screw M10x12, Compression spring 6 and Steel ball 7.9. Then turn over the Table section in the direction of arrow. (Fig. 31)

Fig. 31



The small parts designated with an asterisk can be removed using a bar or screwdriver magnetized with No.1R288.

► Repair

[3] DISASSEMBLY/ASSEMBLY

[3] -7. Table Section (cont.)

DISASSEMBLING

6) Now the Table section can be removed from Guide fence by unscrewing nine M6x20 Hex socket head bolts from the back side of Table complete. (**Fig. 32**)

7) Remove Hex socket head bolt M8x50 and Flat washer 8 from each end of Guide fence. (**Fig. 33**)

8) Insert a slotted screwdriver into the hole of Sleeve 8 on each end of guide fence, and lever it out from the hole of Frame as illustrated to left in **Fig. 34**.

Note:

Hold Guide fence by hand to prevent from falling down.

Now Guide fence can be separated from Frame as illustrated to right in **Fig. 34**.

Fig. 32

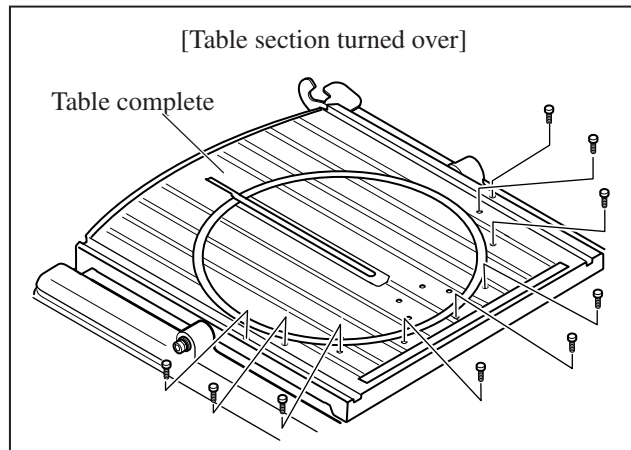

Fig. 33

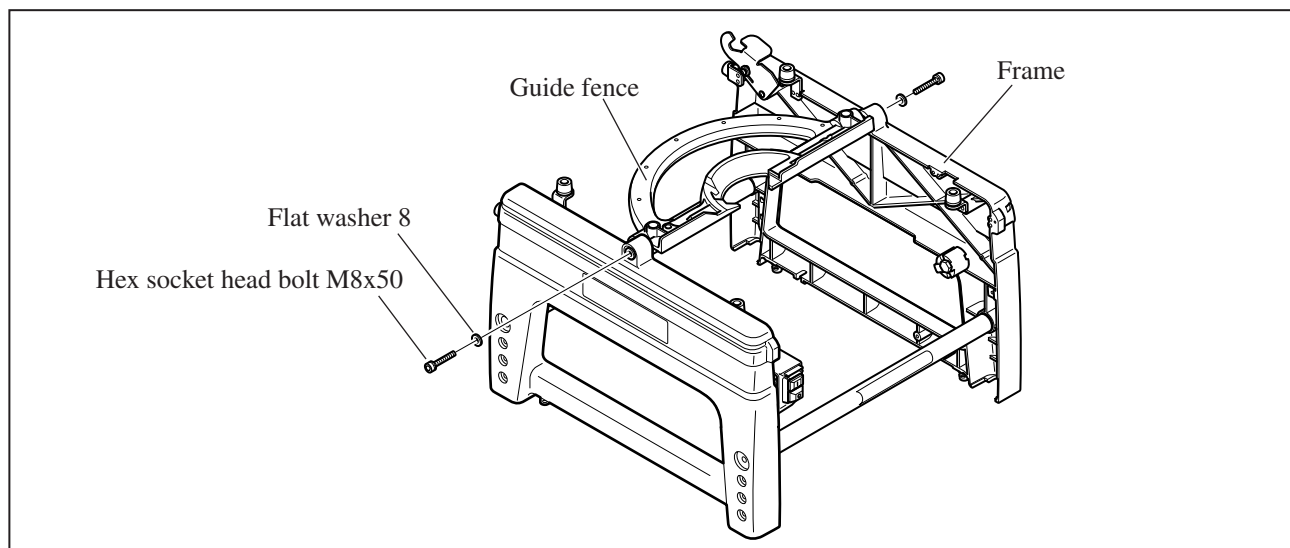
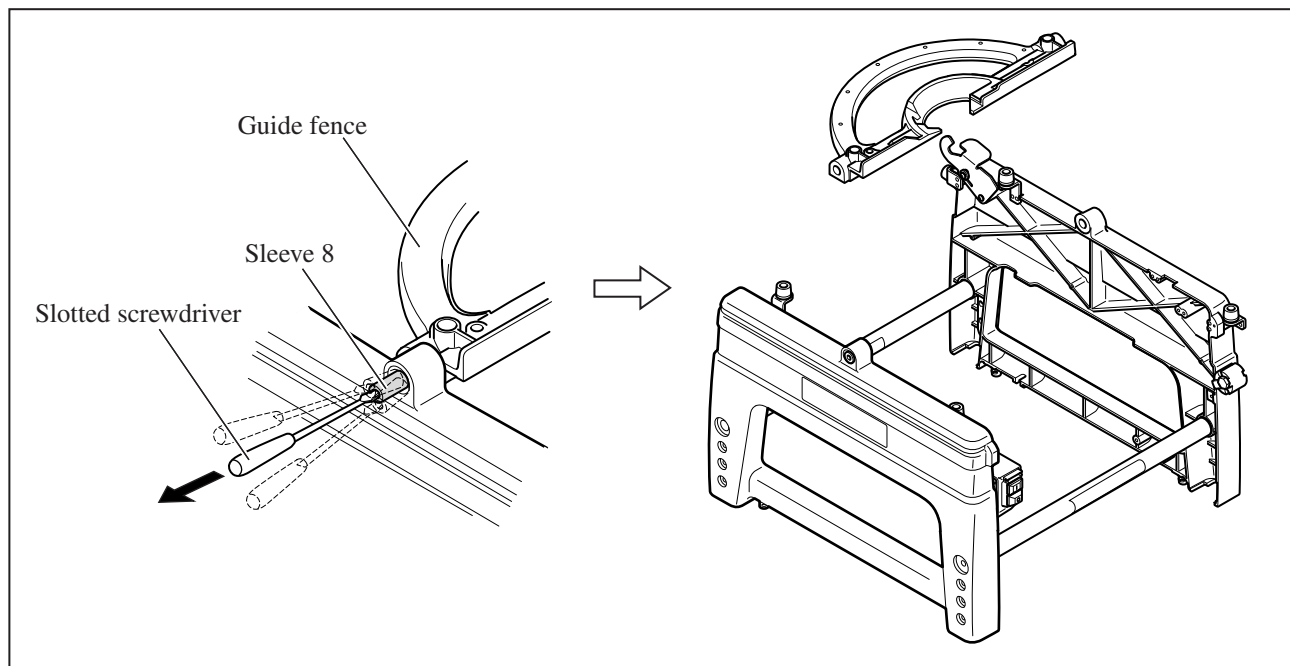

Fig. 34



► Repair

[3] DISASSEMBLY/ASSEMBLY

[3] -7. Table Section (cont.)

DISASSEMBLING

- 9) Lever (Lock lever) is fastened to Frame with each two pieces of Hex socket button head bolt M6 and Flat washer 7.
When removing Lever, follow the instruction described in **Fig. 35**.

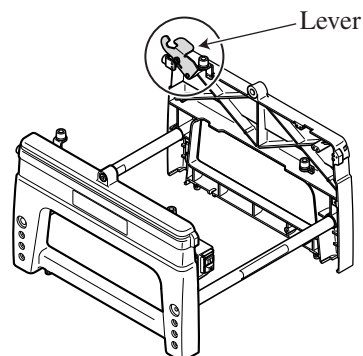
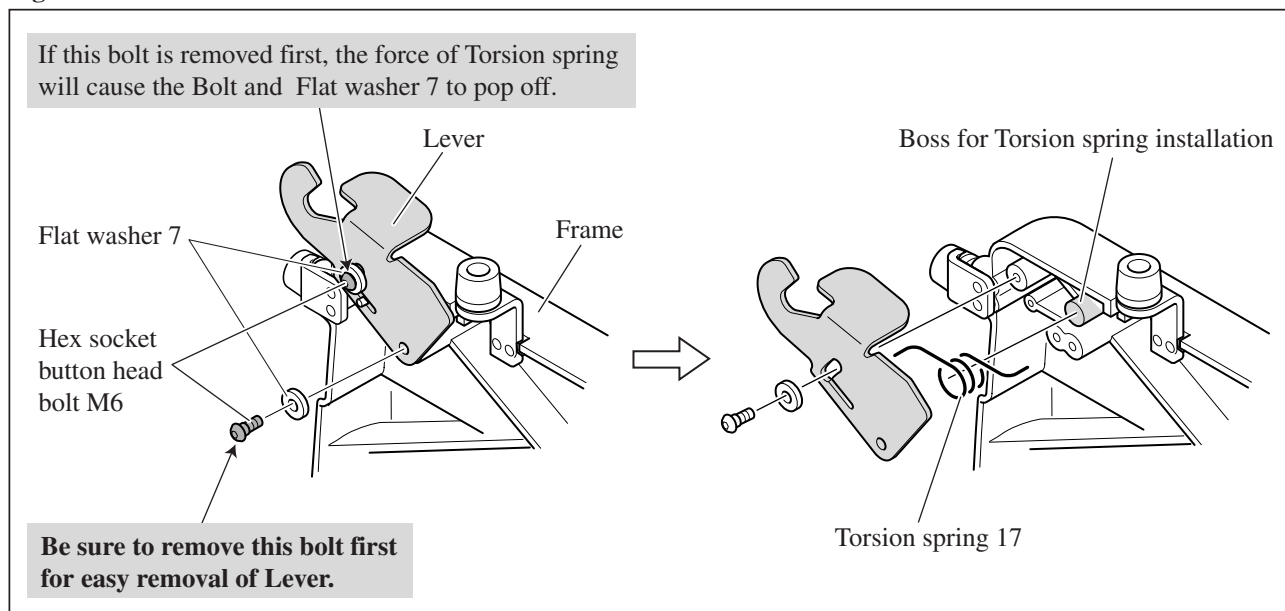

Fig. 35



ASSEMBLING

Do the reverse of the disassembling steps 1) - 9).

Note:

When installing Torsion spring 17 on Frame, insert the spring straight over the boss till it touches the inside wall of Frame. Be careful not to tilt the spring. (**Fig. 36**)

Fig. 36

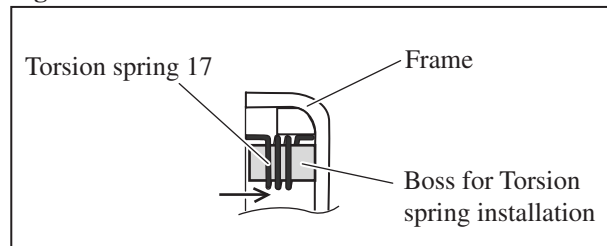

► **Repair**

[3] **DISASSEMBLY/ASSEMBLY**

[3] **-8. Frame Section**

DISASSEMBLING

- 1) After removing Switch box, place the Frame section as illustrated in **Fig. 37**, and remove four Square pipes by unscrewing eight M8x20 Hex socket head bolts.
- 2) Place the Frame section as illustrated in **Fig. 38**. Then, by removing four M10 Hex nuts from Pipe 32 complete (with Makita mark label) and Pipe 32 (without Makita mark label), separate right Frame from left Frame.

Fig. 37

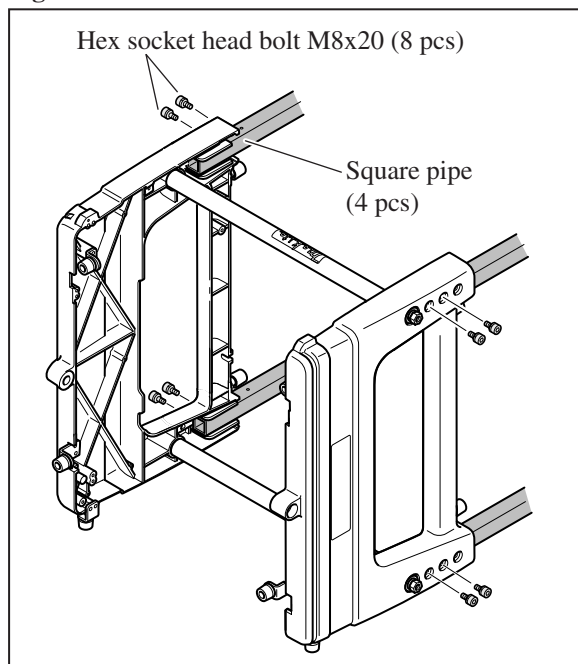
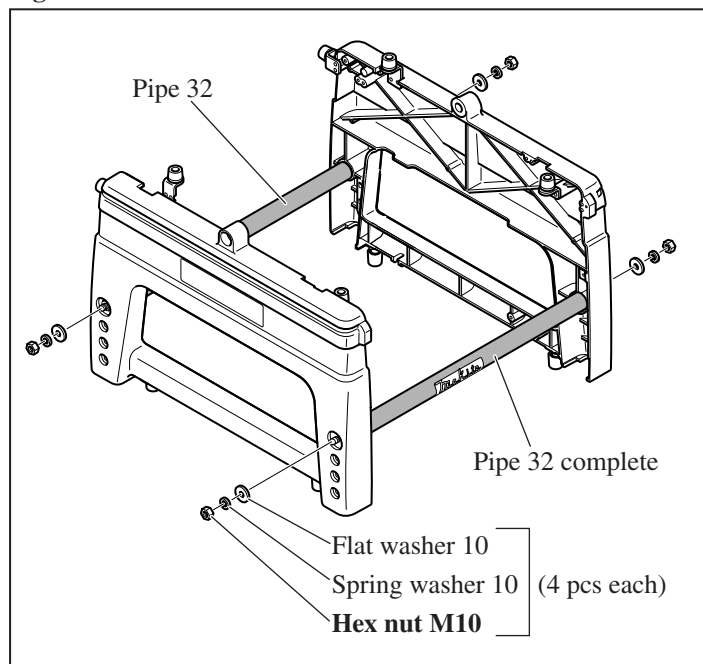

Fig. 38



- 3) From each of *right and *left Frames, remove Pipe 32 complete (Pipe 32) and Screw M10. (**Fig. 39**)
 - 4) Caps can be removed from Frame by tapping the joint of Cap and Frame with slotted screwdriver. (**Fig. 40**)
- Note:** Do not reuse Caps removed from Frame because it is deformed or damaged when removed.

Fig. 39

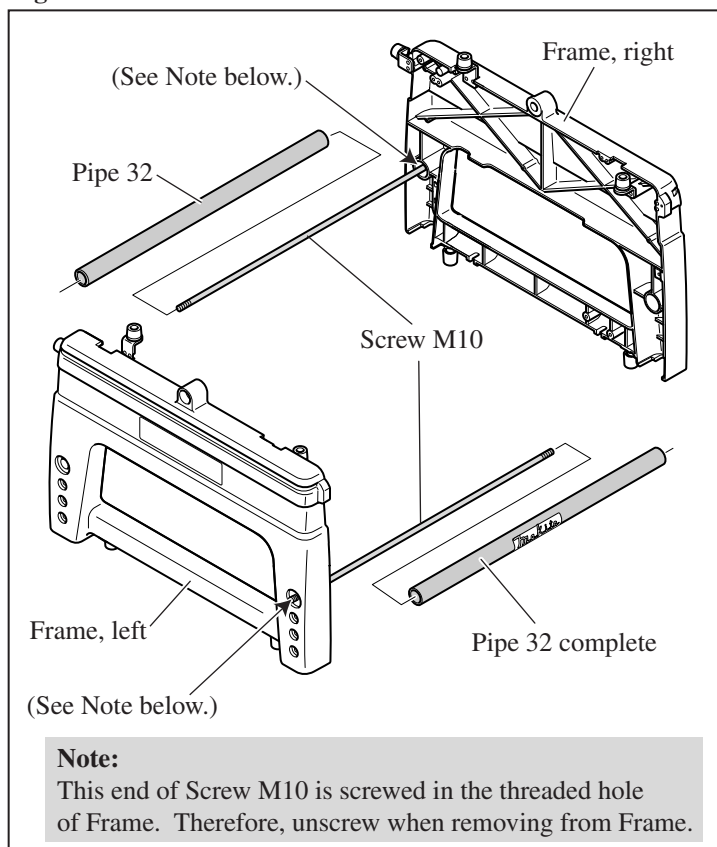
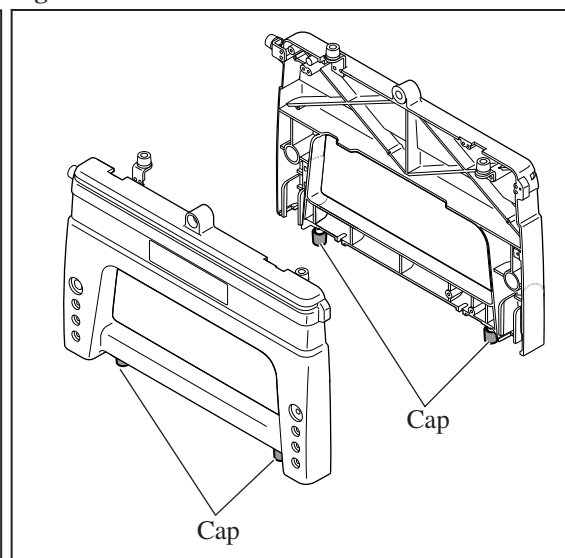

Fig. 40



***Right Frame and Left Frame;**
 Are exactly the same in size and shape. However, some different parts such as Switch box or Lock lever are assembled to them. For convenience, therefore, we call the one on operator's right hand "Right Frame" and the other "Left Frame".

► **Repair**

[3] DISASSEMBLY/ASSEMBLY

[3] -8. Frame Section (cont.)

ASSEMBLING

- 1) Fasten Screw M10 to left Frame/ right Frame so that Pipe 32 complete/ Pipe 32 covers 2 pitches of the thread portion on the opposite side of the screw when the pipe is set in place over the screw. **(Fig. 41)**

Fig. 41

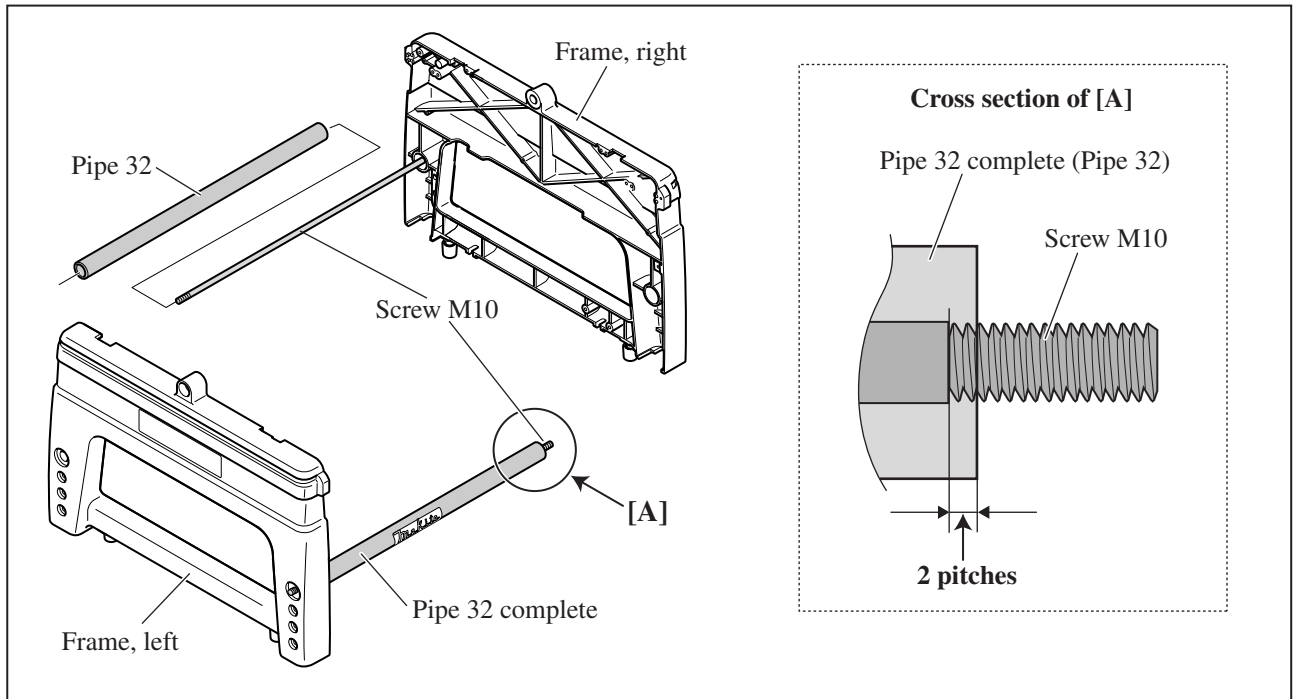

- 2) Tighten Frames with four M10 Hex nuts. **(Fig. 38)**
- 3) Assemble Lever to the right Frame. **(Fig. 35 and 42)**
- 4) Assemble Switch box to the left Frame. **(Fig. 42)**
- 5) Install each three Cushions to the right and left Frames.

Then to the right frame, fasten Leaf spring with Pan head screw M4x10, and fasten two M6 screws. **(Fig. 43)**

Fig. 42

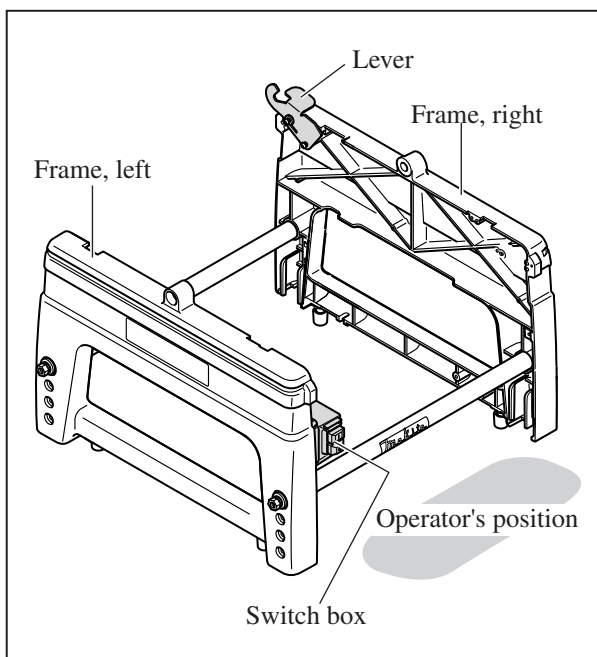
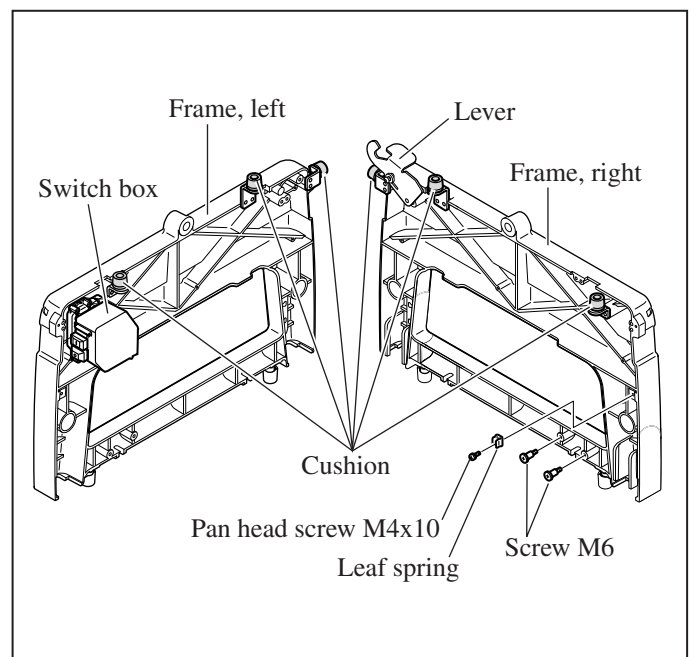

Fig. 43



► **Repair**

[3] DISASSEMBLY/ASSEMBLY

[3] -9. Assembling Feet Section

LEFT FEET SECTION

- 1) For smooth folding action of the Feet section, follow the steps described below to assemble Support bracket to Square pipes precisely at an angle of 90 degrees:
 - i) Put Support bracket on Square pipe 32-510, while keeping about 238 mm distance from the top of Support bracket to the top end of Square pipe. You don't need to tighten hex bolt M6x45 securely in this step.
Then while applying angle ruler to Square pipe and Support bracket, adjust the angle to 90 degrees. (**Fig. 44**)
 - ii) While keeping the 90 degrees obtained in the previous step, tighten the bolt securely to fasten Support bracket to Square pipe 32-510.
 - iii) Fasten Support bracket to Square pipe 32-475 as the same way you have done in the steps i) and ii).
The distance between Square pipe 32-510 and Square pipe 32-475 will be about 529mm if Support bracket is assembled correct to the two pipes. (**Fig. 45**)

Fig. 44

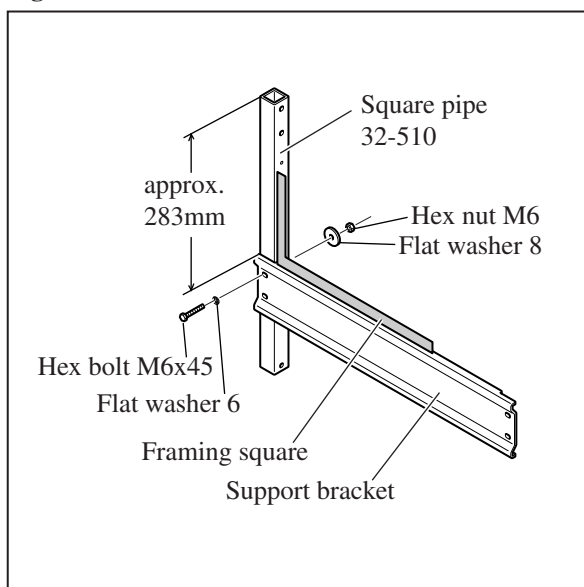
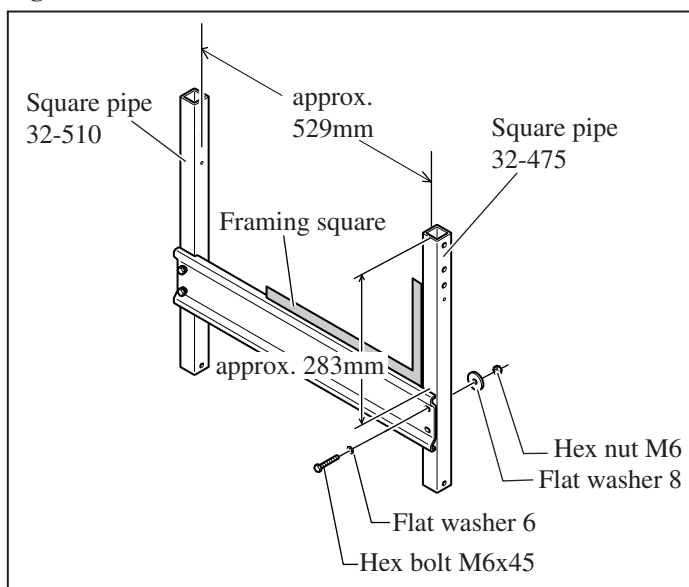

Fig. 45



- 2) See **Fig. 46**. Mount Bracket on Square pipe 32-510 from the Support bracket installation side.
Put Pin 8 (long) through Flat washer 8, elliptic holes of Bracket and the first holes from the top of Square pipe 32-510. And secure the Pin 8 with another Flat washer 8 and Stop ring E-6. Then assemble another Pin 8 (long) in the second hole from the top of the Square pipe as illustrated below.
- 3) See **Fig. 47**. Assemble Bracket to the first hole from the top of Square pipe 32-475 as the same way you have done in the step 2). Then assemble Pin 8 (long) in the second hole from the top, and Pin 8 (short) in the third hole from the top as illustrated below.

Fig. 46

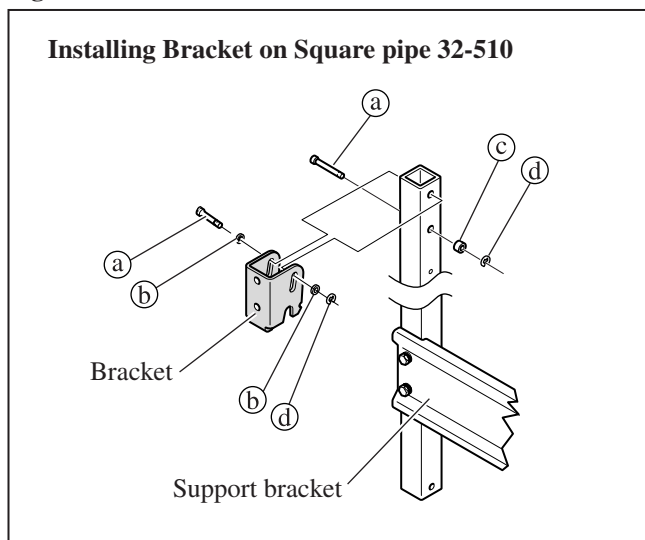
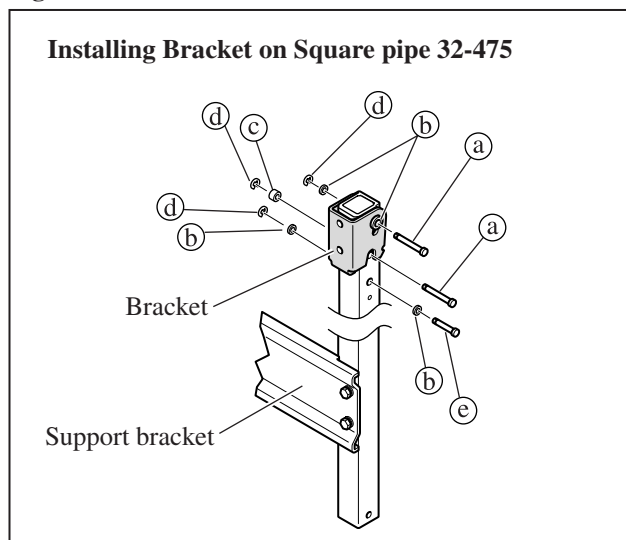

Fig. 47



- Ⓐ Pin 8 (long) Ⓑ Flat washer 8 Ⓒ Sleeve 8 Ⓓ Stop ring E-6 Ⓔ Pin 8 (short)

► **Repair**

[3] **DISASSEMBLY/ASSEMBLY**

[3] **-9. Assembling Feet Section (cont.)**

LEFT FEET SECTION

4) To Square pipe 32-510, assemble Hook and Foot. And to Square pipe 32-475, assemble Stopper hook and Foot nut. (Fig. 48)

Fig. 48

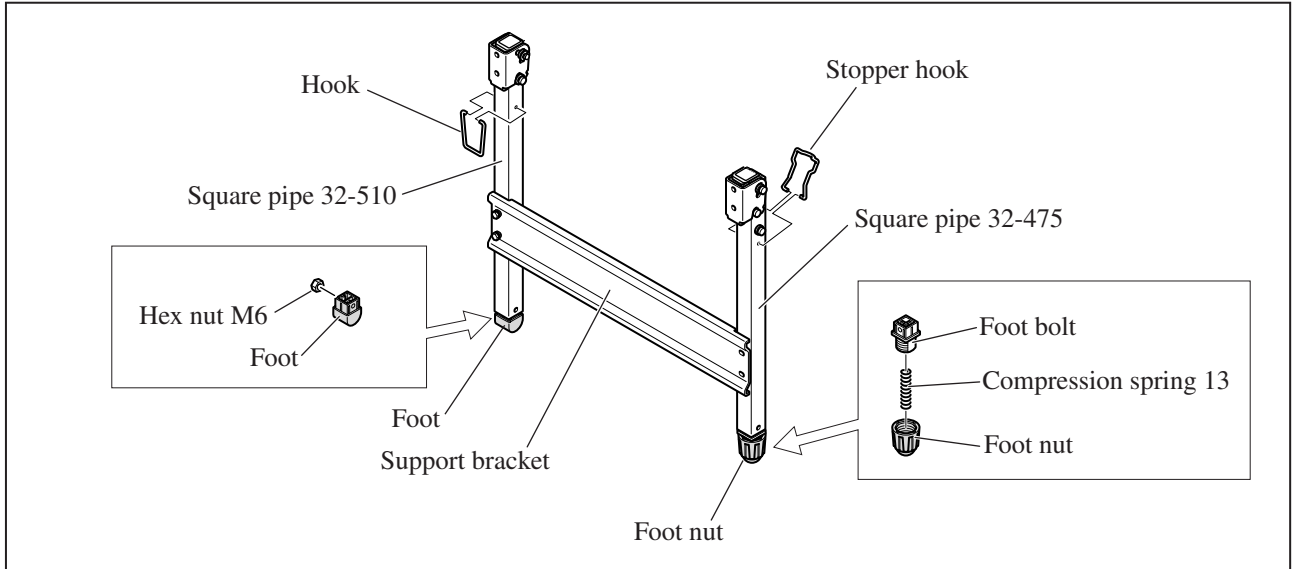

RIGHT FEET SECTION

Note: Different from the Left feet section, two 32-475 Square pipes are used for the right Feet section.

- 1) The same way as you did in assembling the left feet section;
Assemble Support bracket to Square pipes precisely at an angle of 90 degrees. (Fig. 45, 46)
Then assemble Bracket and Pin 8 to each Square pipe. (Fig. 47, 48)
- 2) Assemble Stopper hook to the Square pipe 32-475 on the side of operator's position. (Fig. 49)
- 3) Mount Foot to each Square pipe. (Fig. 49)

Fig. 49

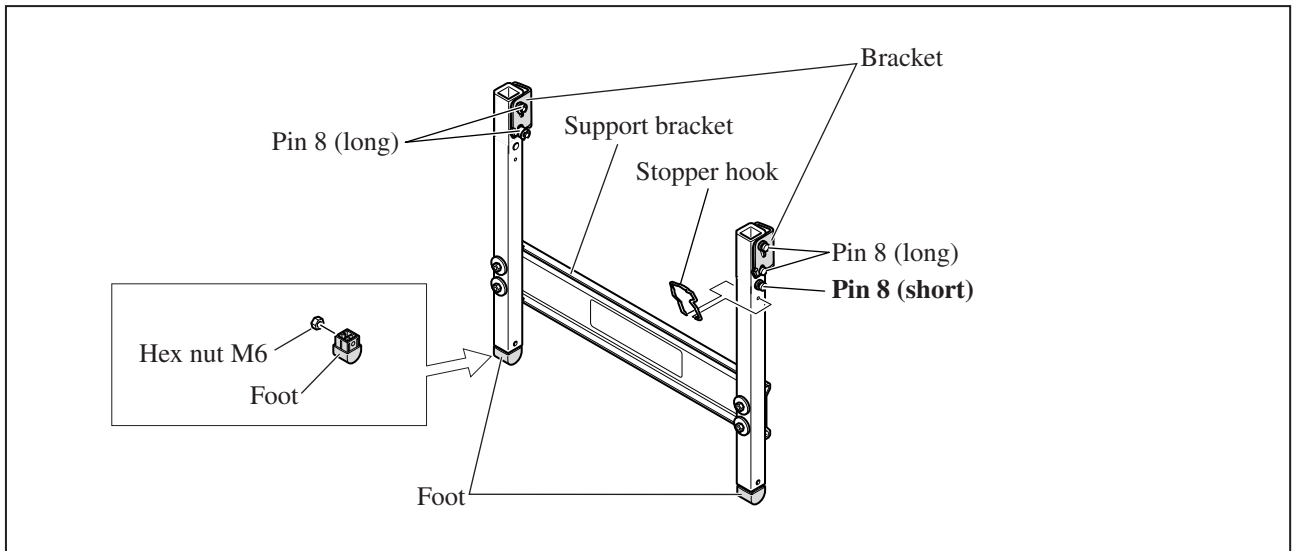

► **Repair**

[3] **DISASSEMBLY/ASSEMBLY**

[3] -10. **Assembling Feet Section to Frame Section**

With eight M8x20 Hex socket bolts, fasten the left Feet section to Frame, left; and the right Feet section to Frame, right.

Important:

- a) Before assembling, be sure that the following parts are in the correct position as illustrated in **Fig. 50**.
- b) Fasten with the bolts as illustrated in **Fig. 51**.

If not assembled as illustrated below, it will be impossible to fold the feet section or obtain a flat table surface.

Fig. 50

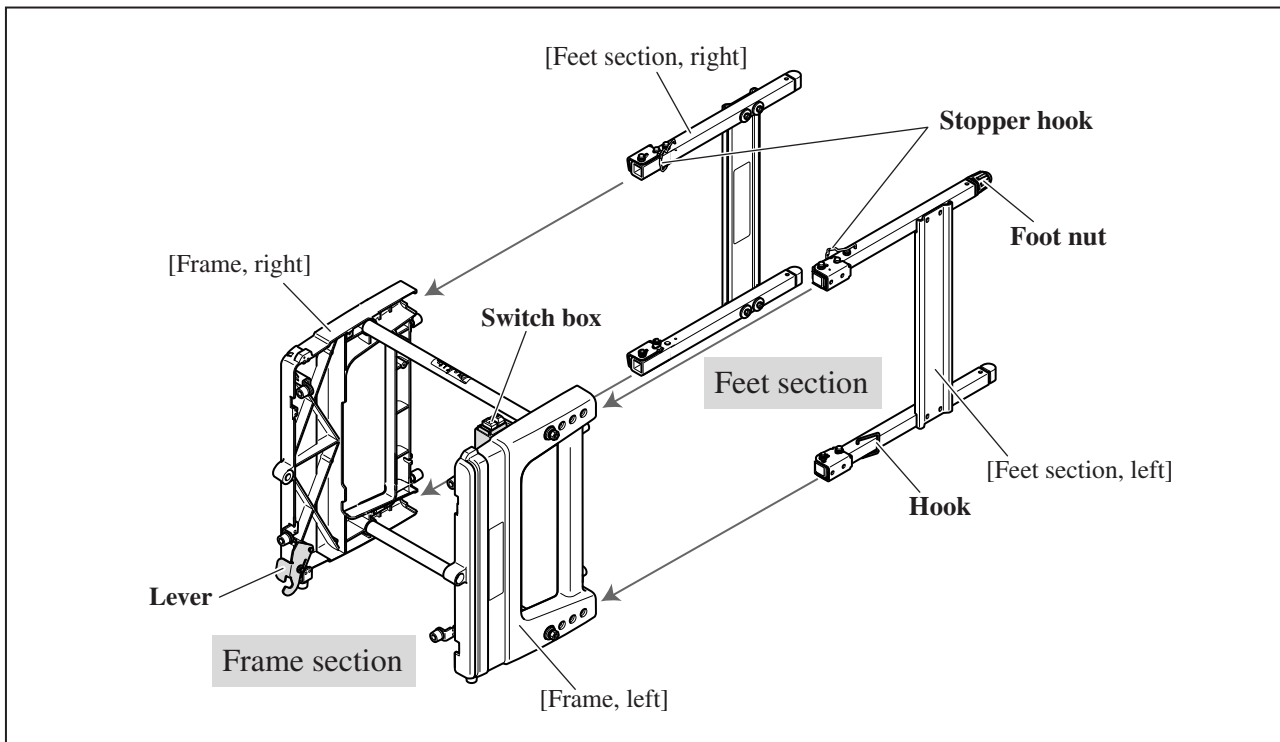
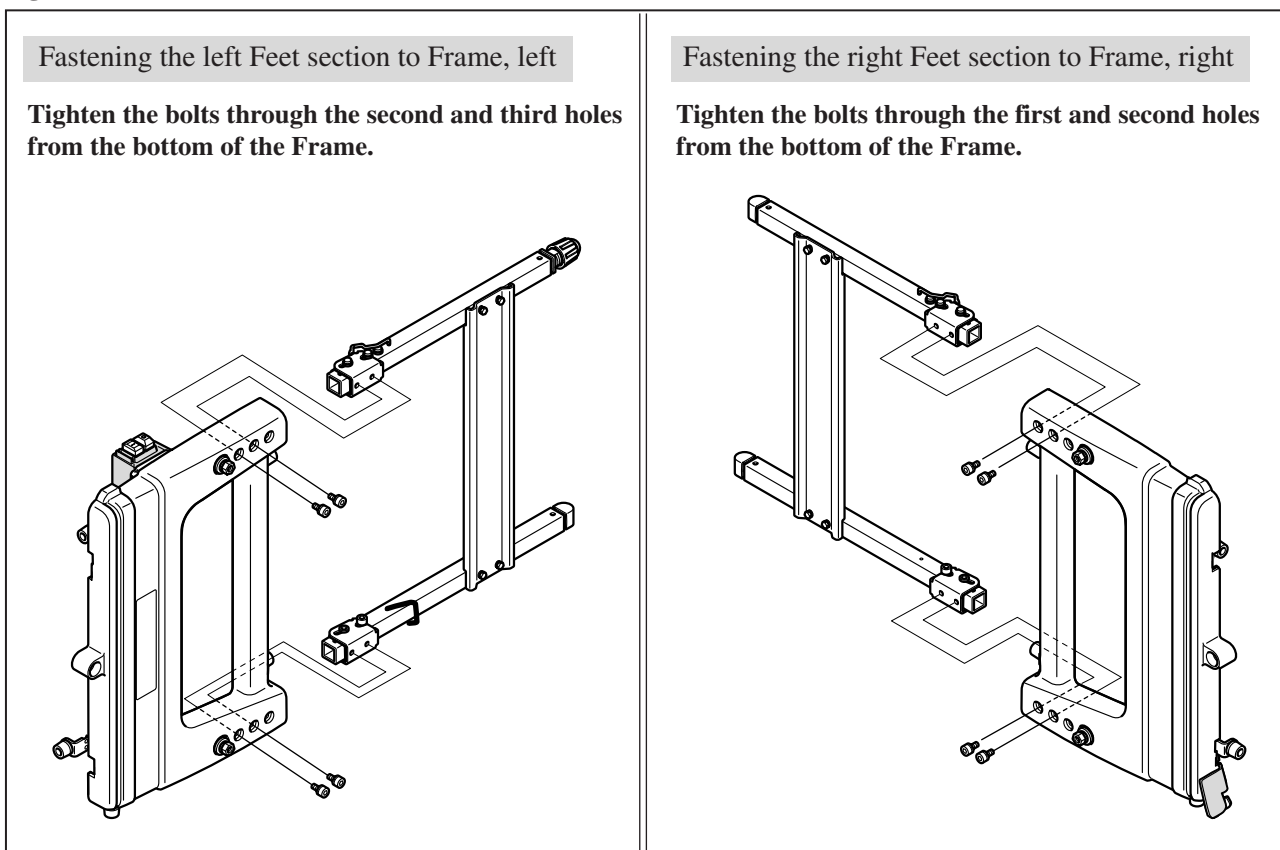

Fig. 51



► **Repair**

[4] ADJUSTMENT

[4] -1. Adjusting Bevel Angle

0 Degree Bevel

- 1) Lock the saw head unit in the full down position, and loosen Lever 100. Then rotate the 90 degree adjusting screw two or three turns counterclockwise using Hex wrench 3, and tilt the blade to the right. **(Fig. 52)**
- 2) Put 90 degree set square (No.1R208) on the top surface of Turn table and beside the blade. Turn the 0 degree adjusting screw carefully clockwise until No.1R208 closely contacts the blade without gap between their surfaces and between the surfaces of No.208 and Turn table. Then tighten Lever 100. **(Fig. 53)**
- 3) After performing this adjustment, make sure that the pointer of Indication plate is indicating 0 degree on Bevel scale. If not, loosen the screw that fastens Indication plate and adjust the pointer to 0 degree.

Fig. 52

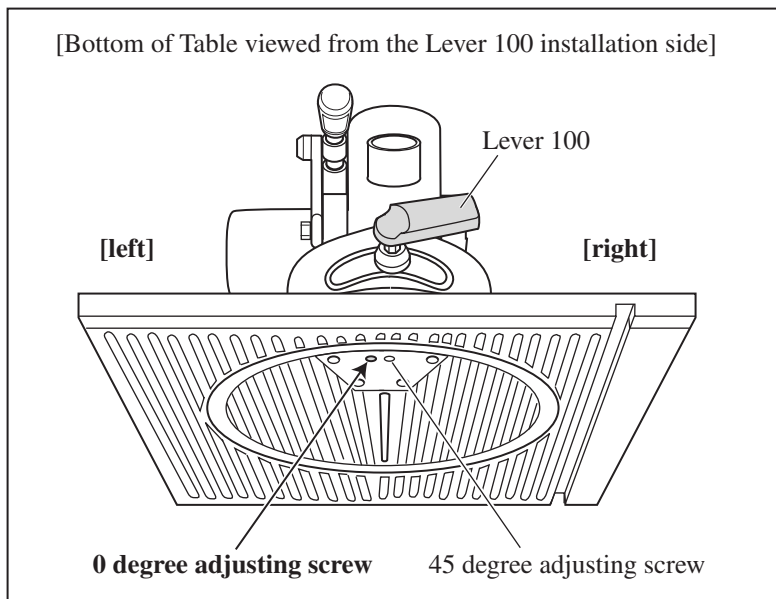
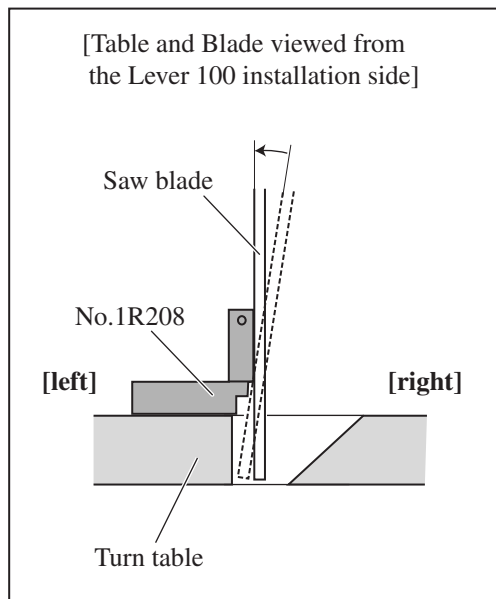

Fig. 53



45 Degree Bevel

Important: Before performing 45 degree bevel angle adjustment, be sure to do 0 degree bevel angle adjustment.

- 1) Tilt the saw head unit fully to the right. **(Fig. 54)**
- 2) Put 45 degree set square (No.1R207) on the top surface of Turn table and beside the blade. Turn the 45 degree adjusting screw carefully clockwise until No.1R207 closely contacts the blade without gap between their surfaces and between the surfaces of No.207 and Turn table. Then tighten Lever 100. **(Fig. 55)**
- 3) After performing this adjustment, make sure that the pointer of Indication plate is indicating 45 degrees on Bevel scale. If not, loosen the screw that fastens Indication plate and adjust the pointer to 45 degrees.

Fig. 54

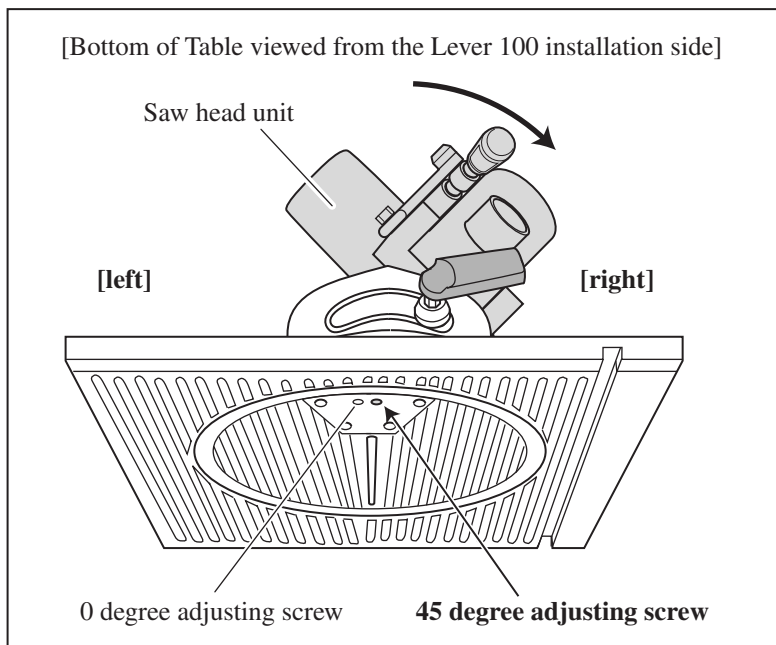
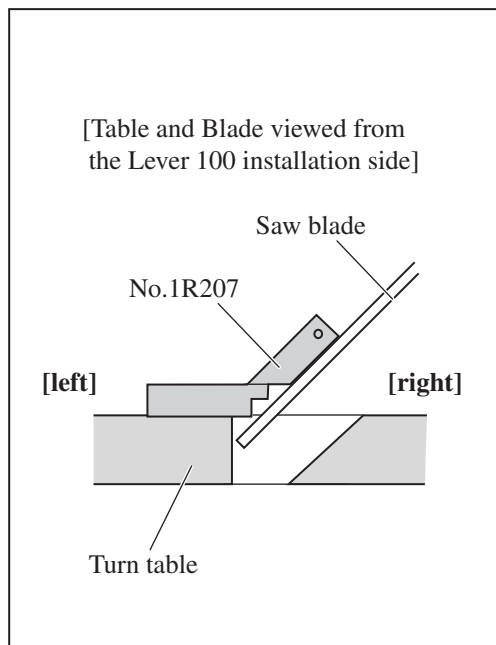

Fig. 55



► Repair

[4] ADJUSTMENT

[4] -2. Adjusting Miter Angle

In case of LF1000, it is impossible to adjust miter angle by moving Guide fence because the Guide fence is designed also as the axis on which Table is flipped over.

Therefore, adjust miter angle by moving the saw head unit carefully as follows:

- 1) Lock the saw head unit in the full down position.
- 2) Slightly loosen four M6x20 hex socket head bolts that fasten the Arm section to Turn table. **(Fig. 56)**
- 3) Lightly tighten one of the four bolts. Then, applying 90 degree set square (No.1R208) to the side of saw blade and Guide fence, pivot the Arm section slightly on the tightened bolt until No.1R208 closely contacts the side of the saw blade and Guide fence without gap between the surfaces. While keeping the 90 degree angle between the blade and Guide fence, tighten four M6x20 hex socket head bolts securely. **(Fig. 57)**
- 4) After performing this adjustment, make sure that Pointer on Table complete is indicating 0 degree on Miter scale. If not, loosen the screw that fastens Pointer to Table complete and adjust it to 0 degree.

Fig. 56

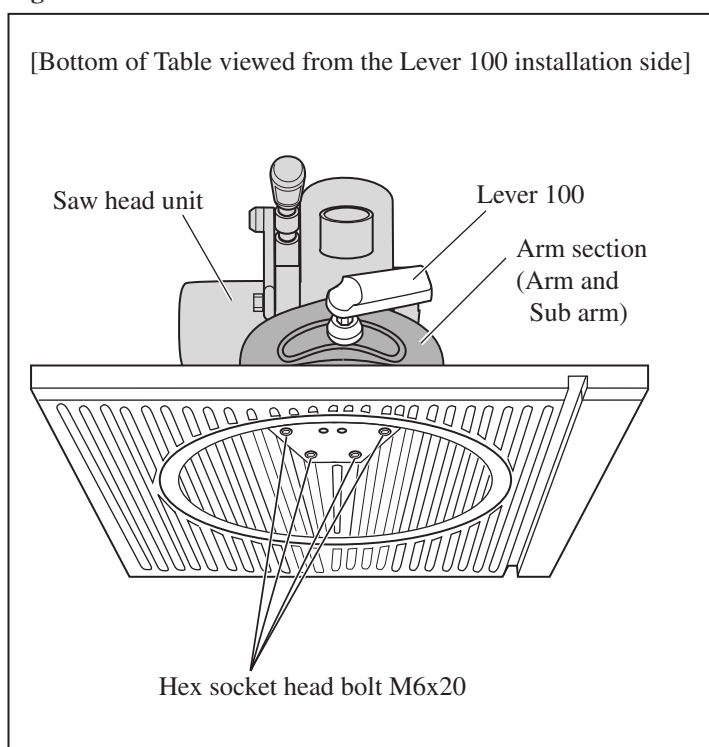
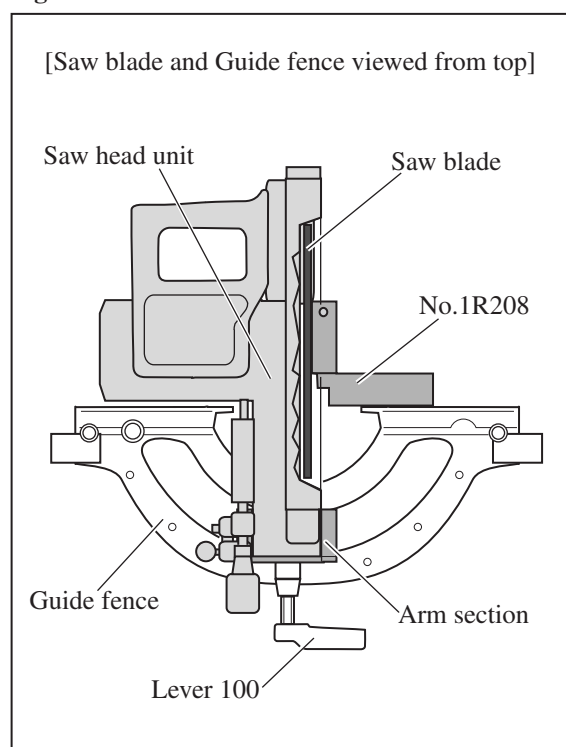

Fig. 57



► **Circuit diagram**

All European Countries Except UK-110V (See page 23 for UK-110V.)

Color index of lead wires' sheath					
Blue		Orange		White	
Brown		Purple		Yellow	
Black		Red			

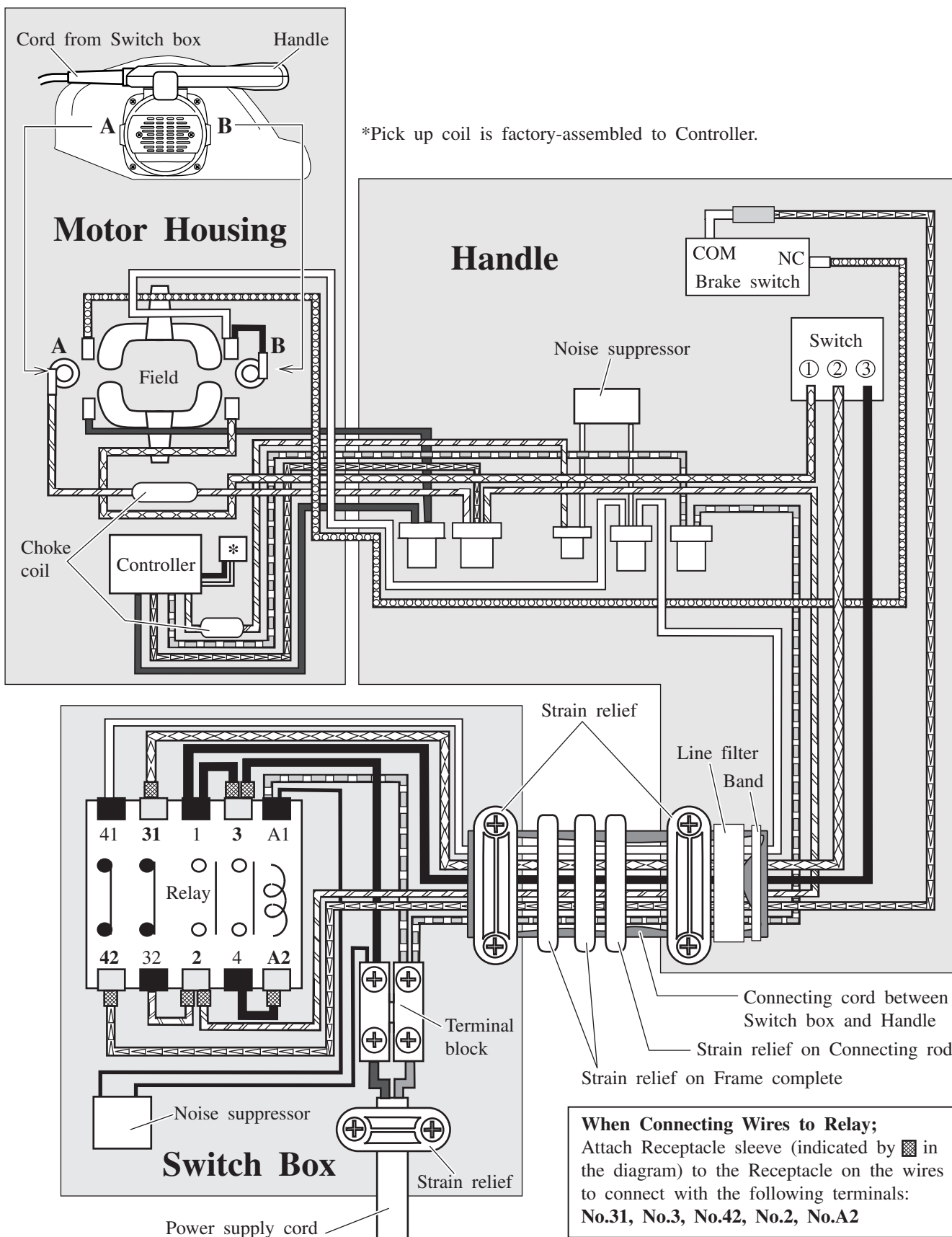

When Connecting Wires to Relay;
 Attach Receptacle sleeve (indicated by in the diagram) to the Receptacle on the wires to connect with the following terminals:
No.31, No.3, No.42, No.2, No.A2

► **Circuit diagram**

UK-110V

Color index of lead wires' sheath					
Blue		Orange		White	
Brown		Purple		Yellow	
Black		Red			

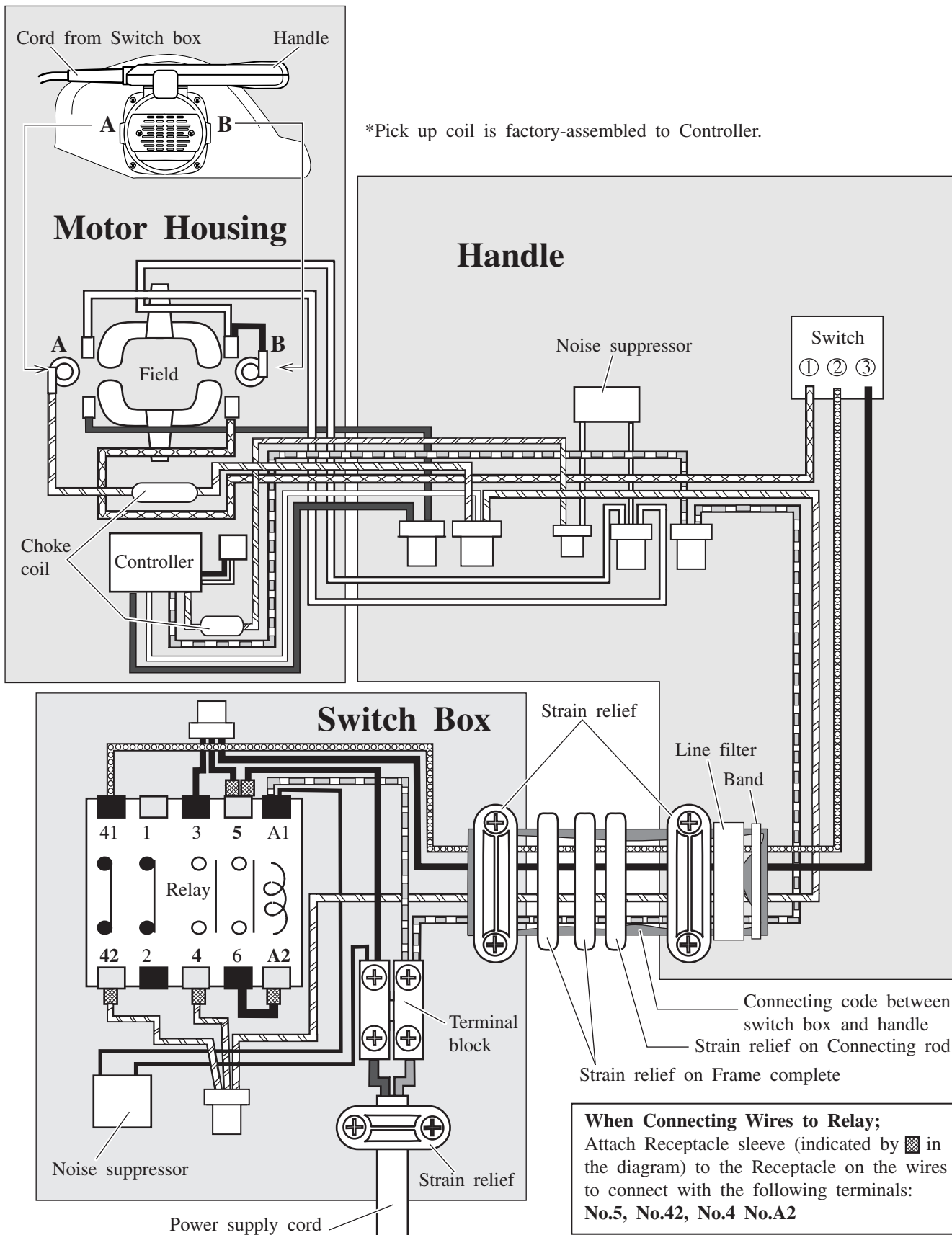

▶ Wiring diagram

All European Countries Except UK-110V (See page 28 for UK-110V)

[1] Wiring on the Rear End Surface of Motor Housing

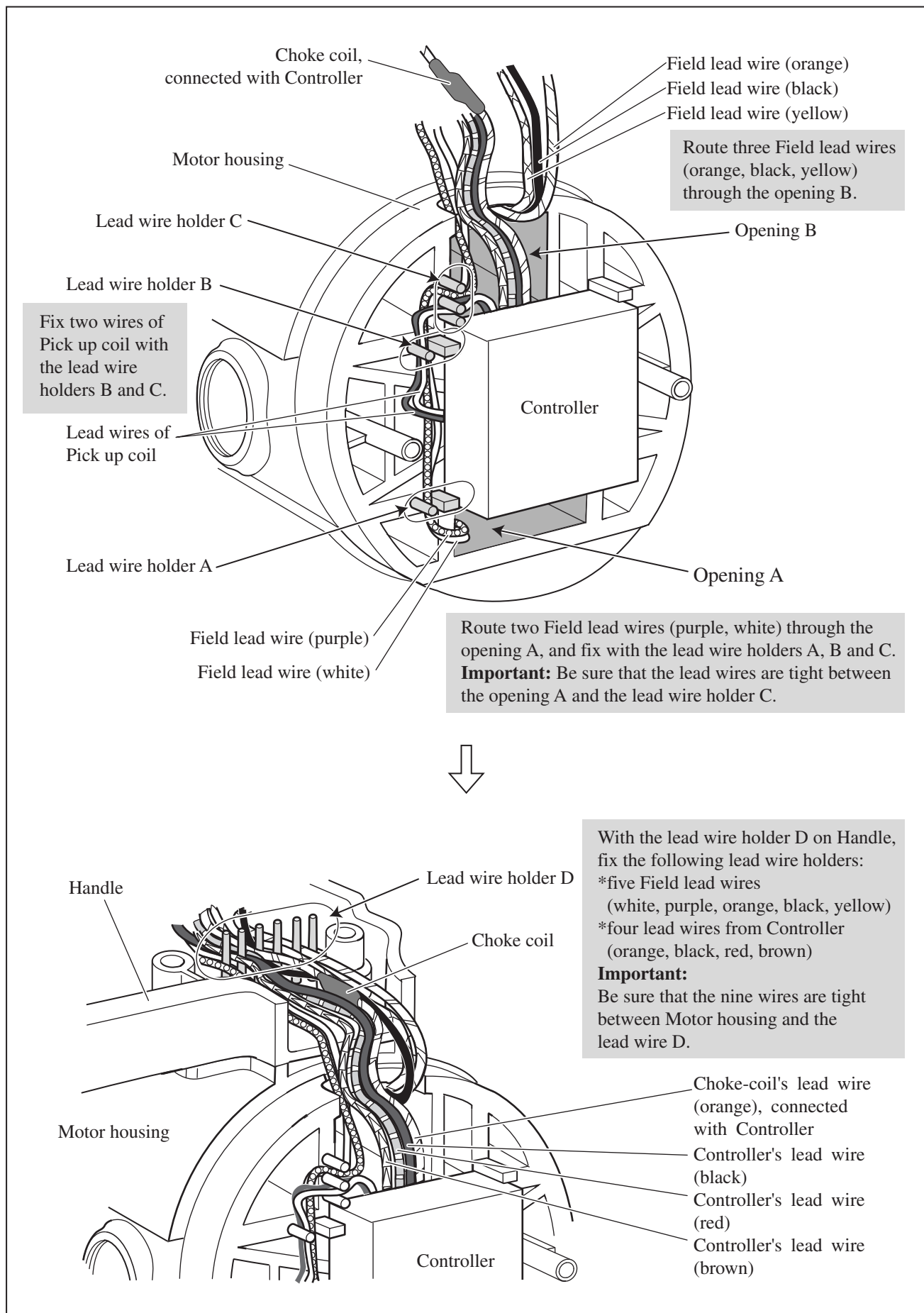

► Wiring diagram

All European Countries Except UK-110V (See page 29 for UK-110V)

[2] Wiring in Handle

- Put Line filter between Strain relief and Band.
- Install Connecting cord and Band on Handle so that;
 - *the distance between the end of Connecting cord and the inside wall A is 10 - 20mm
 - *the distance between the end of Connecting cord and Band is 10 - 20mm.

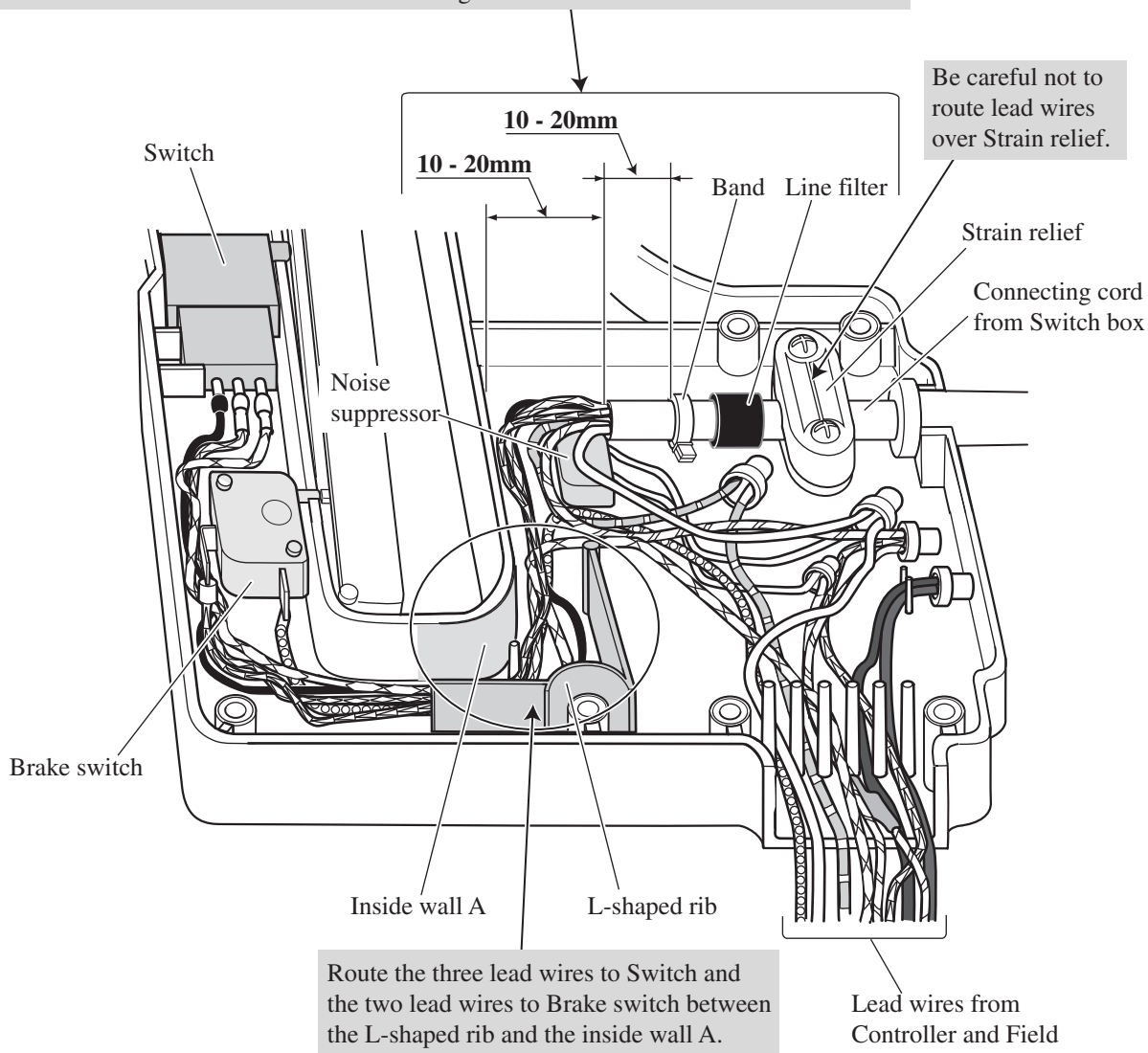

How to Connect lead wires to Brake switch

Connect lead wires to Brake switch as illustrated below.

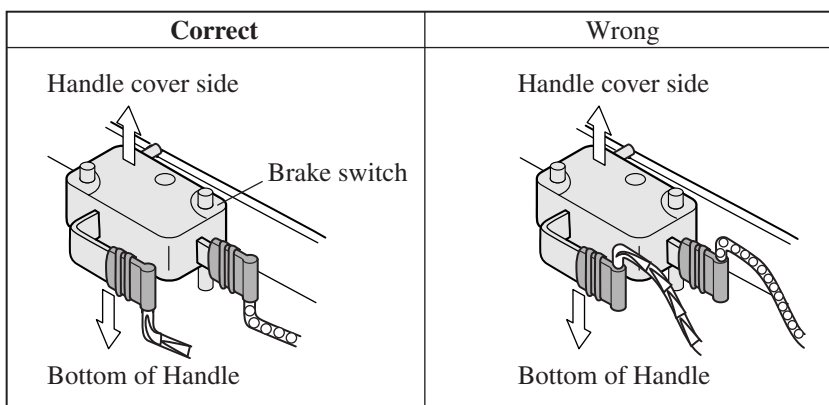

► **Wiring diagram**

All European Countries Except UK-110V (See page 30 for UK-110V.)

[3] Wiring in Switch Box

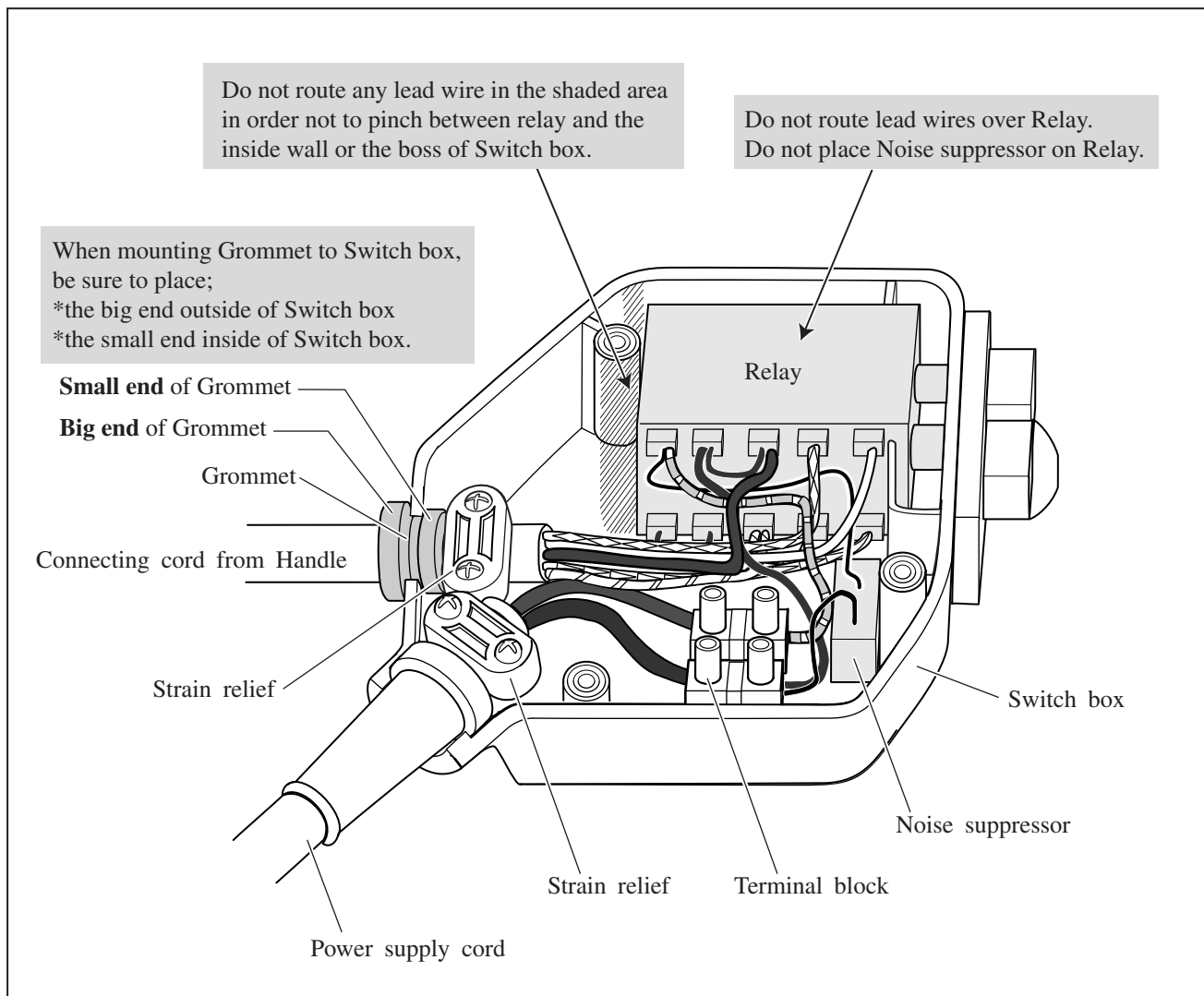

► **Wiring diagram**

All Countries

[4] Wiring at Connecting Rod

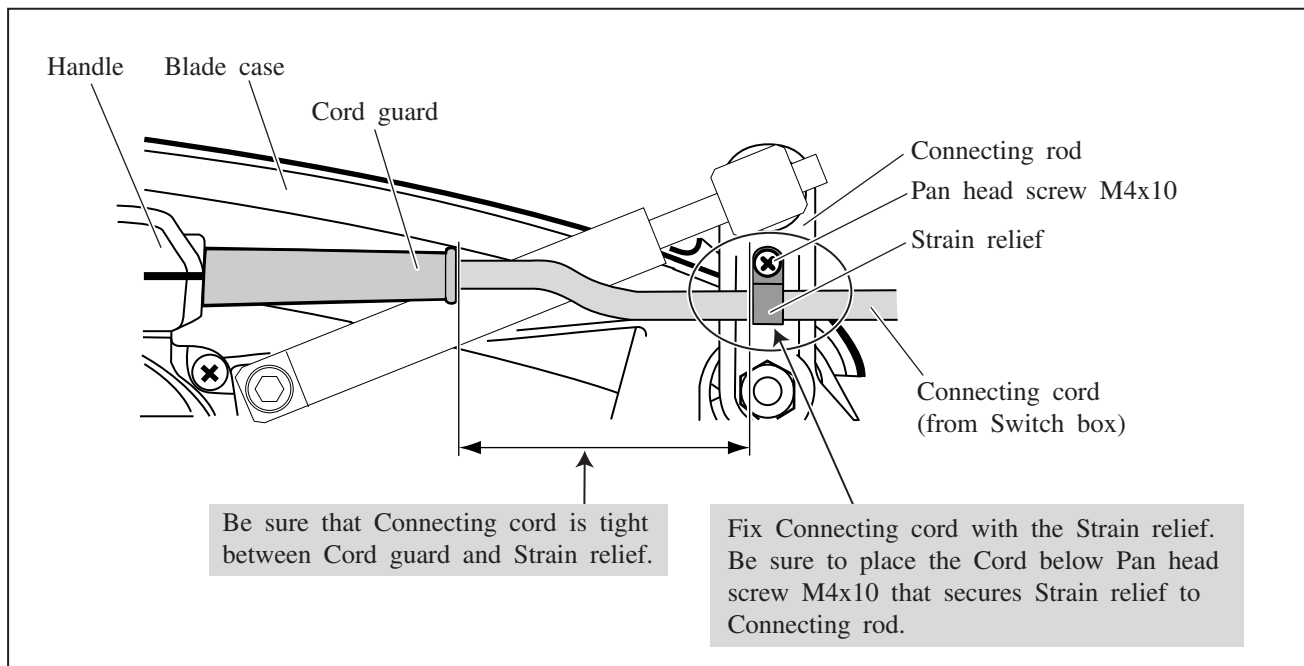

[5] Wiring Under Table

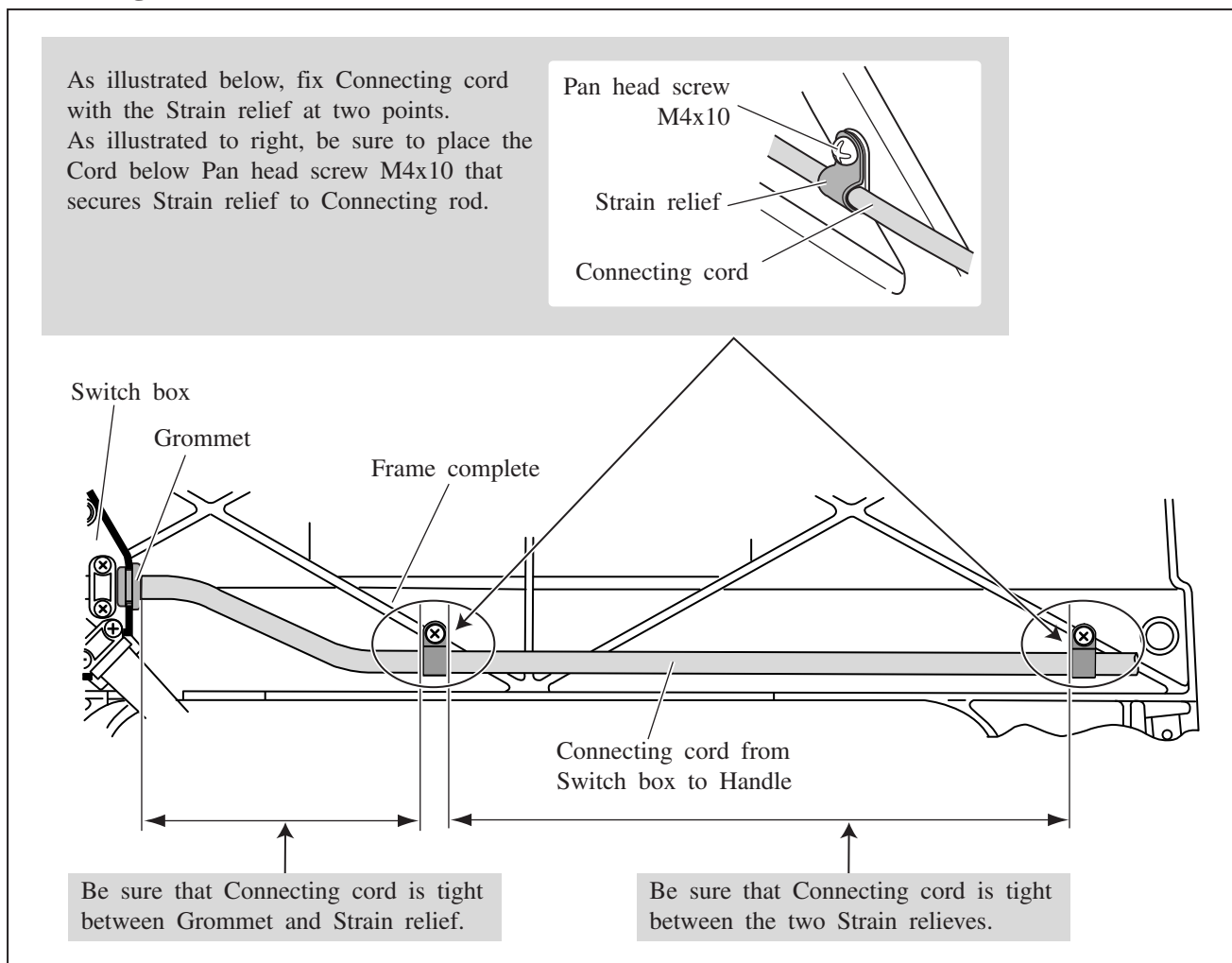

► **Wiring diagram**

UK-110V

[1] Wiring on the Rear End Surface of Motor Housing

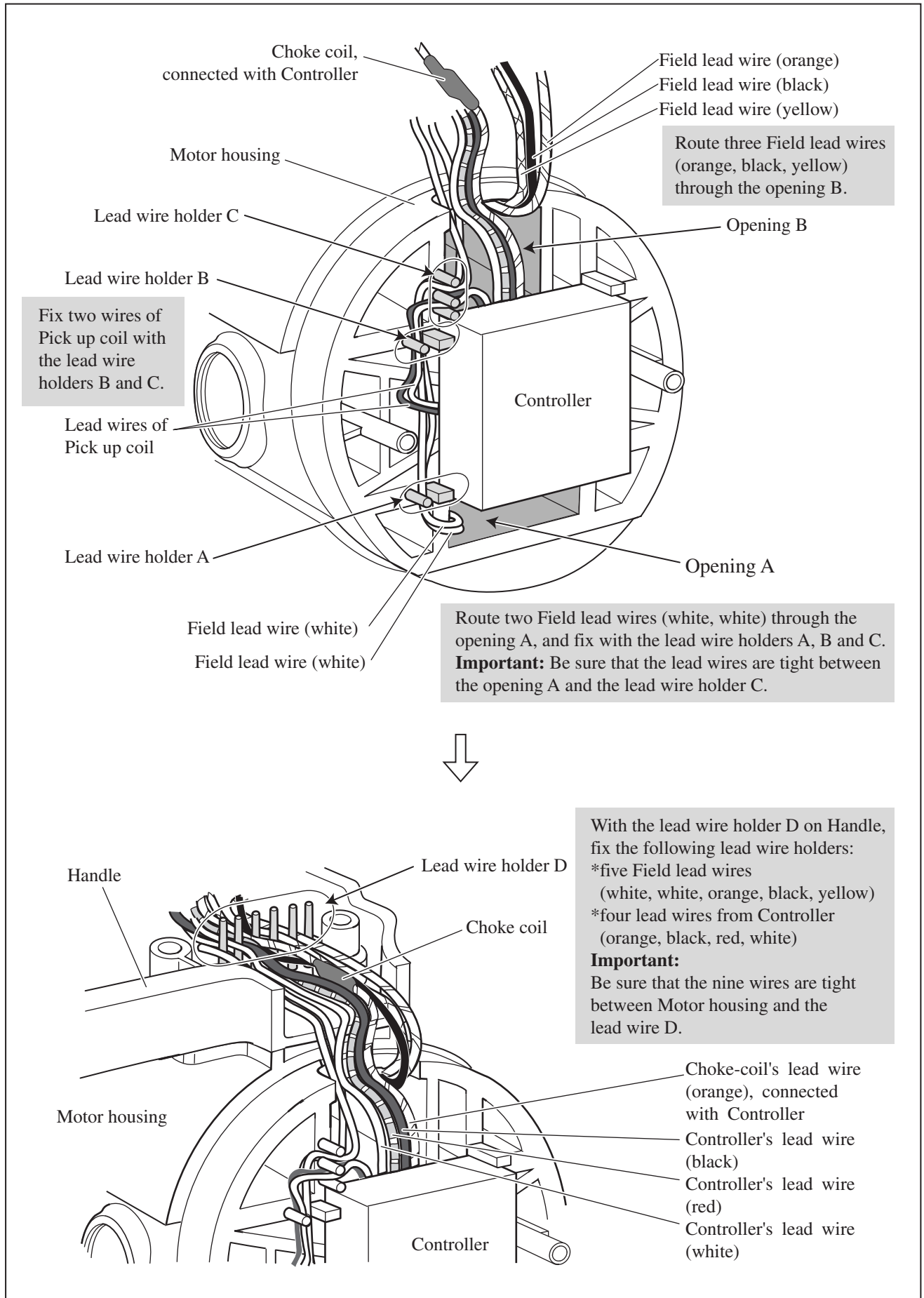

▶ Wiring diagram

UK-110V

[2] Wiring in Handle

- Put Line filter between Strain relief and Band.
- Install Connecting cord and Band on Handle so that;
 - *the distance between the end of Connecting cord and the inside wall A is 10 - 20mm
 - *the distance between the end of Connecting cord and Band is 10 - 20mm.

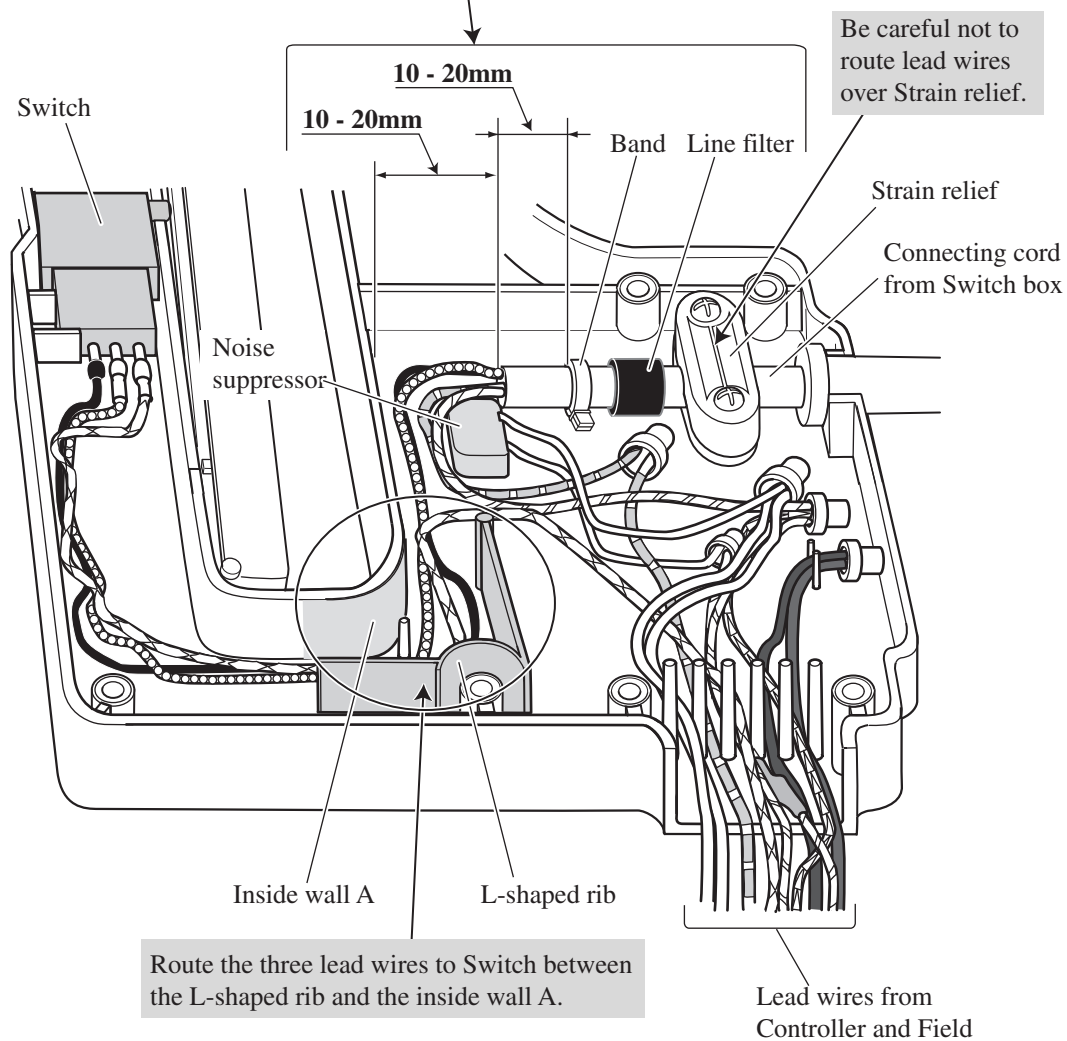

► Wiring diagram

UK-110V

[3] Wiring in Switch Box

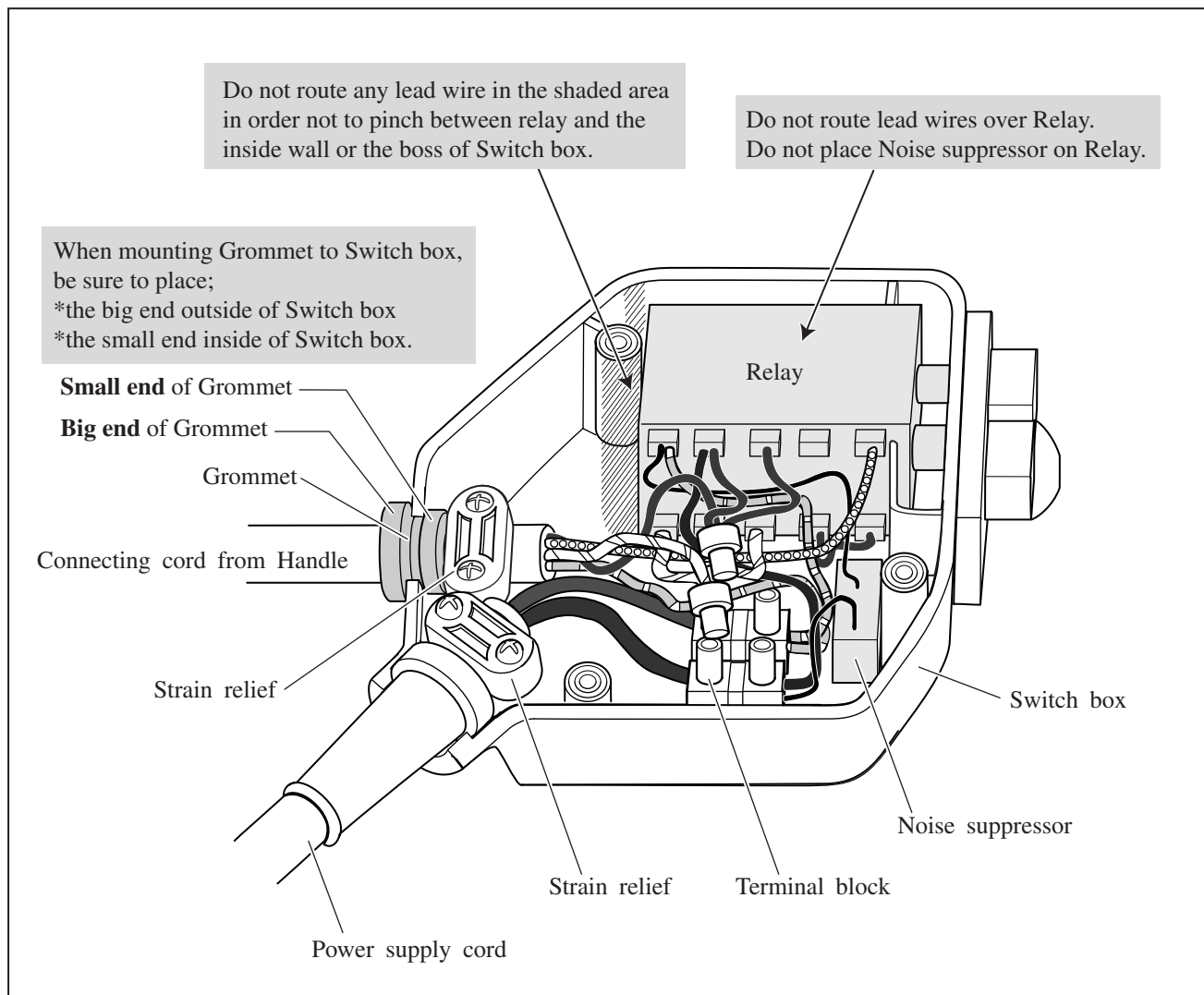

[4] Wiring at Connecting Rod

Do the same way as "All European Countries Except UK-110V". (See page 27.)

[5] Wiring Under Table

Do the same way as "All European Countries Except UK-110V". (See page 27.)

Free Manuals Download Website

<http://myh66.com>

<http://usermanuals.us>

<http://www.somanuals.com>

<http://www.4manuals.cc>

<http://www.manual-lib.com>

<http://www.404manual.com>

<http://www.luxmanual.com>

<http://aubethermostatmanual.com>

Golf course search by state

<http://golfingnear.com>

Email search by domain

<http://emailbydomain.com>

Auto manuals search

<http://auto.somanuals.com>

TV manuals search

<http://tv.somanuals.com>