

TECHNICAL INFORMATION



PRODUCT

P 1 / 14

Models No. ▶ EX2650LH

Description ▶ Multi Function Power Head

CONCEPT AND MAIN APPLICATIONS

Model EX2650LH loaded with 25.4mL Makita 4-stroke engine is a power head designed for versatile garden and agricultural applications.

The following advantages make this product ideal for a wide range of garden and agricultural applications:

- Split system of Power head and Attachment provides easier mobility.
- Clean 4-stroke engine equipped with our unique multi-position engine lubrication system that enables the engine to be inclined to any angle with no emission of white smoke and smell of burning engine oil even during continuous operation
- Multi-tool system consisting of the power head and versatile optional attachments

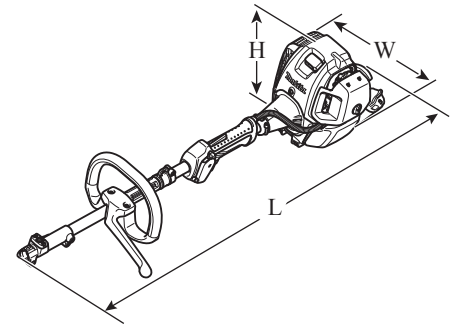

Dimensions: mm (")	
Length (L)	975 (38-3/8)
Width (W)	242 (9-1/2)
	323 (12-3/4)*1
Height (H)	241 (9-1/2)

*1: for the countries where Barrier bar is required by the standards of brushcutter.

► Specification

Engine	Type	4-stroke
	Displacement: cm ³ (cu.in.)	25.4 (1.55)
	Fuel	Straight unleaded gasoline*2
	Max. output: kW	0.77 (at 7,000 min. ⁻¹)
	Max. torque: N.m	1.1 (at 5,500 min. ⁻¹)
Engine oil	SAE10W-30 oil in the class SF or higher of API Classification	
Carburetor	Diaphragm	
Starting system	Recoil starter, with mechanical decompression	
Fuel tank capacity: mL (US oz)	600 (20.3)	
Primer pump	Yes	
Clutch	Yes	
Handle style	Loop handle	
Rapid start	No*3	
Net weight*4: kg (lbs)	4.6 (10)	

*2: Brazil: 25E gasoline

*3: However, equipped with mechanical decompression

*4: Dry weight

► Standard equipment

Shoulder harness with single shoulder strap	1
Socket wrench 16-17	1
Hex wrench 4	1
Accessory bag	1
Oil set (oil bottle containing 80mL engine oil)	1

Note: The standard equipment for the tool shown above may vary by country.

► Optional accessories

Brush cutter attachment	Cultivator attachment
String trimmer attachment	Coffee harvester attachment
Pole saw attachment	Carrying bag
Pole hedge trimmer attachment	

► Repair

CAUTION: Repair the machine in accordance with “Instruction manual” or “Safety instructions”.

[1] NECESSARY REPAIRING TOOLS

Code No.	Description	Use for
1R004	Retaining ring pliers ST-2 for External ring	removing/ assembling Retaining ring S-12
1R006	Retaining ring pliers RT-2E for Internal ring	removing/ assembling Retaining ring R-24
1R028	Bearing setting pipe 20-12.2	pressfitting Spiral bevel gear 14 (the component of Cutter shaft set)
1R031	Bearing setting pipe 28-20.2	removing Spiral bevel gear 14 (the component of Cutter shaft set)
1R033	Bearing setting plate 10.2	removing Cutter shaft set
1R045	Gear extractor (large)	removing Ball bearing 6001LLU
1R127	Air density tester	diagnosing Carburetor
1R171	T-type hex. wrench 4-130	removing / assembling M5 Hex socket head bolt
1R247	Round bar for arbor 20-100	removing Clutch drum
1R282	Round bar for arbor 8-50	removing Spiral bevel gear 14 (the component of Cutter shaft set)
1R286	Round bar for arbor 12-50	pressfitting Clutch drum
1R291	Retaining ring S and R pliers	removing / assembling Retaining rings
1R364	Flywheel puller	removing Flywheel
1R366	Feeler gauge set	Adjusting Ignition coil, Spark plug and Rocker arm assembly
—	Hex socket bit 13	removing / assembling Flywheel
—	Wire brush	making Spark plug clean
—	M10-17 Hex. nut	removing Cutter shaft set

[2] HANDLING OF GASKET

When Gasket is removed:

- (1) clear something that is sticking on the matching portions with Gasket.
- (2) replace Gasket with the new one.

[3] LUBRICANT / ADHESIVE APPLICATION

Apply a little amount of Makita grease N No.2 to Spiral spring in Recoil starter and the spline ends of Shaft.

Apply 8g Makita grease N No.2 into Gear case after cleaning the inside.

Once the engine is disassembled, put ThreeBond 1216 to the matching surface of Crank case and Cylinder block for the reassembly. (Fig. 64)

[4] DISASSEMBLY/ASSEMBLY

[4]-1. Warning

Obey the following instructions in advance before repairing.

- Wear gloves.
 - Keep the cover on the blade other than a trial of engine running.
 - Cool down engine enough, as the engine just after used may cause you to get burned.
 - Remove the remaining fuel in Tank and Carburetor completely.
 - Repair the engine on the stable workbench and in the clean workplace to prevent dust and debris from entering.
 - Record where and how the parts are assembled, and what are the parts. Do not reassemble them wrongly.
- It is recommended to prepare the several kind of boxes to keep parts group by group.
- Treat the disassembled parts carefully. Clean and wash them certainly.
 - When some bolts and screws are difficult to loosen, use Impact driver.
 - Tighten the bolts and the screws to the specific torque as shown in Fig. 68.
 - Once the main parts are assembled, check every move and sound by manually turning each part.
 - Check the assembled parts by turning them manually if there is any unusual gap or sound around.

► Repair

[4] DISASSEMBLY/ASSEMBLY

[4]-2. Engine and Shaft

DISASSEMBLING

- (1) Disconnect lead wire and grounding wire by removing each connector after removal of Air cleaner cover. **(Fig. 1)**
- (2) Remove Control cable from Insulator as follows:
 - Loosen the nuts of Control cable so as to relax the holding to the hook of Insulator. **(Fig. 2)**
 - Disconnect Inner cable from Swivel of Carburetor.
- (3) Loosen two M5x18 Hex socket head bolts on Pipe holder and remove M5x12 Hex socket head bolt. **(Fig. 3)**
- (4) Pull Shaft pipe B complete and Shaft B complete out of Engine. **(Fig. 4)**

Note: Shaft B complete in the Shaft B pipe complete may get stuck at the spline engagement. If yes, use Waterpump pliers to pull out the shaft. **(Fig. 5)**

Fig. 1

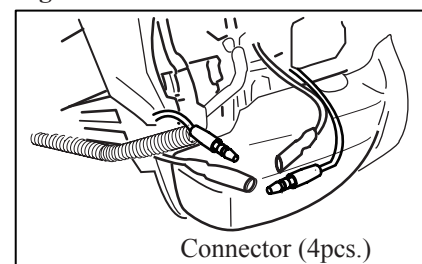

Fig. 2

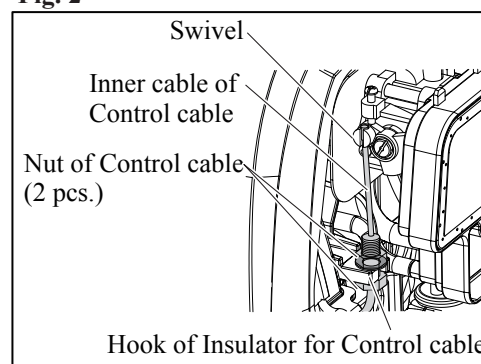

Fig. 3

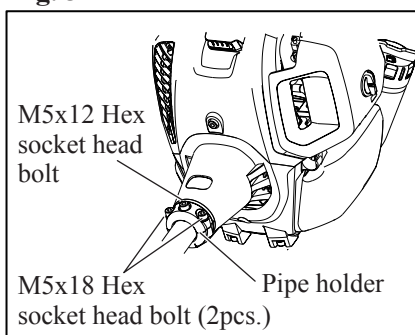

Fig. 4

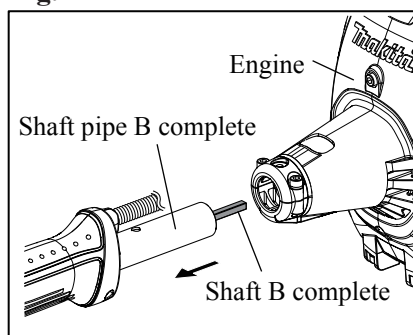
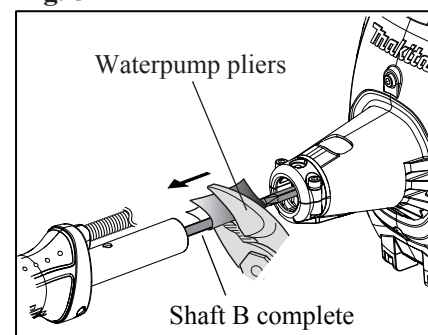

Fig. 5



ASSEMBLING

Assemble by reversing the disassembly procedure.

- Set Control cable in place. **(Figs. 2 and 6)**
 - Secure it on the hook of Insulator with two Nuts of Control cable.
 - Fit Inner cable end into the groove of Swivel of Carburetor.

Note: Adjust the tension of the cable to allow the play 1mm up to 2mm.

Fig. 6

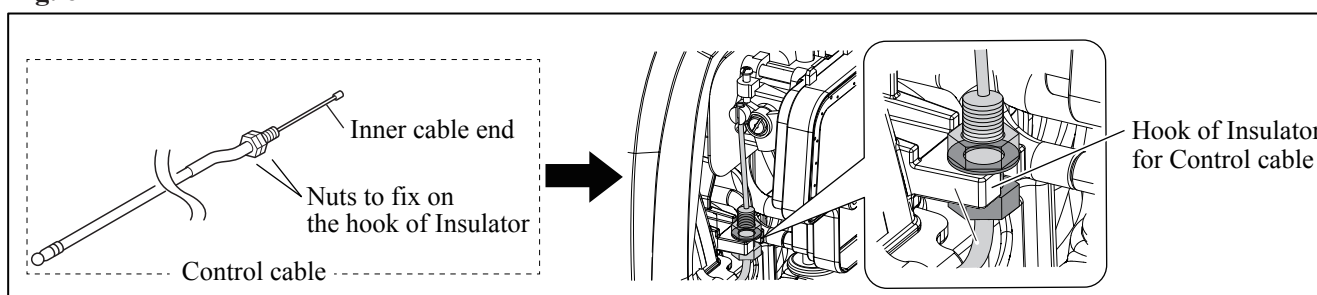

► Repair

[4] DISASSEMBLY/ASSEMBLY

[4]-3. Brushcutter attachment

DISASSEMBLING

- (1) Loosen two M6x30 Hex. socket head bolts and remove Protector with Protector extension attached. (Fig. 7)
- (2) While pulling the side walls of Protector cover toward outside, remove Protector cover from Shaft pipe A complete. (Fig. 8)
- (3) Remove two M5x14 Hex socket head bolts and Protector clamp. (Fig. 9)
- (4) Loosen M5x25 Hex socket head bolt and remove Gear case assembly from Shaft pipe A complete. (Fig. 9)
- (5) Pull Shaft A from Gear case installation side and then remove Retaining ring S-7 from Shaft A. (Fig. 10)
- (6) Push the projection of Leaf spring complete deeply and remove it from the hole of Shaft pipe A complete. Slip the projection along the inside of Shaft pipe A complete toward the shaft end. (Fig. 11) Leaf spring complete is removed from Shaft pipe A complete.

Note: Pushing the projection hard causes the deformation of Leaf spring complete. Be careful of the handling.

Fig. 7

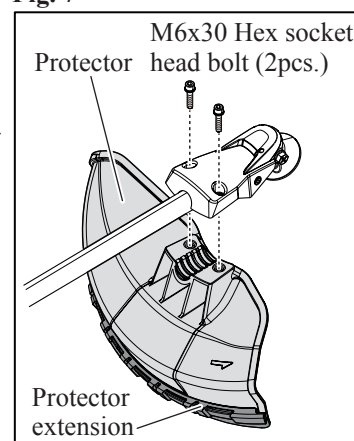

Fig. 8

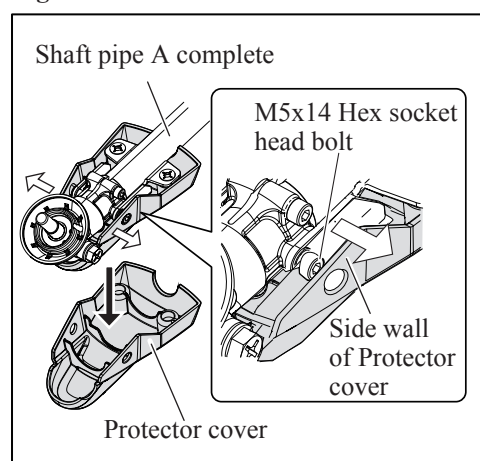

Fig. 9

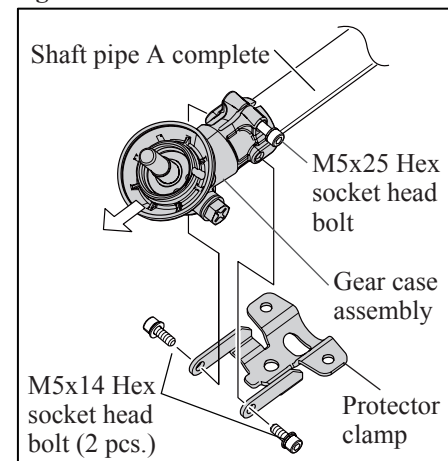

Fig. 10

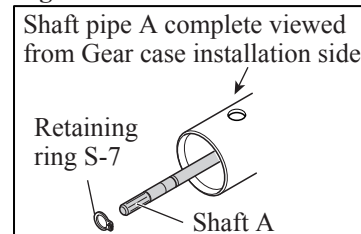
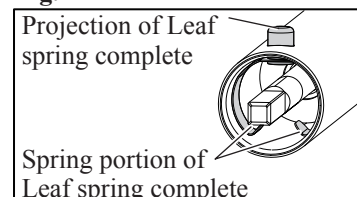

Fig. 11



ASSEMBLING

Assemble by reversing the disassembly procedure.

[4]-4. String trimmer attachment

DISASSEMBLING

- (1) Remove two M6x20 Hex. socket head bolts and Protector from Clamp complete. (Fig. 12)
- (2) Remove M5x10 Hex socket head bolt and Clamp complete from Head case. (Fig. 12)
- (3) Loosen M5x25 Hex socket head bolt and remove Head case from Bent pipe assembly. (Fig. 12)
- (4) Remove Bearing washer from Head case installation side of Bent pipe assembly. (Fig. 13)
Remove Flexible shaft from Bent pipe assembly by pulling it off from shaft joint side.
- (5) Remove two M5x14 Screws. Cutter is removed from Safety cover as drawn in Fig. 14.

Fig. 13

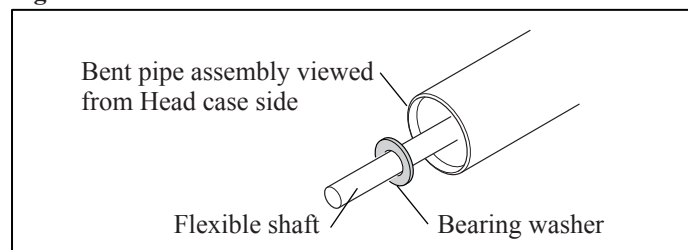

Fig. 12

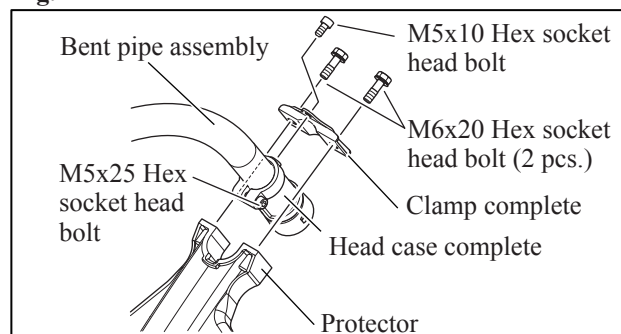
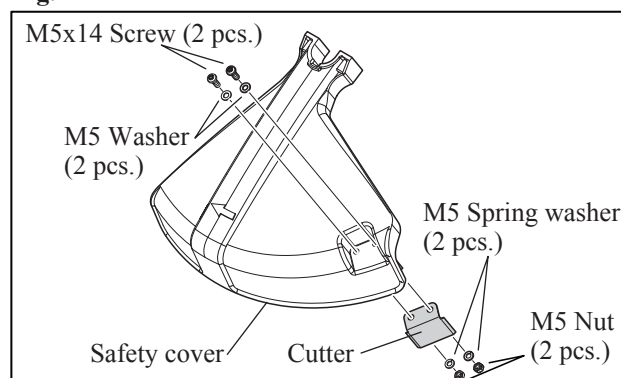

Fig. 14



► Repair

[4] DISASSEMBLY/ASSEMBLY

[4]-5. Gear case assembly

DISASSEMBLING

- (1) According to the clause of [4]-3, Remove Gear case assembly. (Refer to **Figs. 7, 8 and 9**)
- (2) Remove M8x10 + Hex bolt that is the stopper of Grease inlet on Gear case set. (**Fig. 15**)
- (3) Remove Retaining ring R-24 with 1R006. (**Fig. 16**)
- (4) Remove an assembled part of Spiral bevel gear 14, Ball bearing 609ZZ and Retaining ring S-9 by striking Gear case assembly against workbench as drawn in **Fig. 17**.
- (5) Remove Retaining ring S-9 with 1R291.
- (6) Receive Ball bearing 609ZZ with 1R031, then press down the top of Spiral bevel gear 14 using 1R282 with Arbor press (**Fig. 18**) Refer to **Fig. 19** for the components.
- (7) Remove Retaining ring R-28 with 1R291. (**Fig. 20**)
- (8) Preset Receive washer and 1R033 with M10-17 Hex. nut to Cutter shaft as drawn in **Fig. 21**, and give the impacts using the plastic hammer. An assembled part of Cutter shaft complete, Ball bearing 6001LLU is removed. Refer to **Fig. 22** for the components.
- (9) Remove Ball bearing 6001LLU with 1R045.

Fig. 15

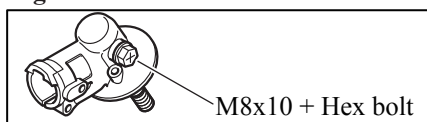

Fig. 16

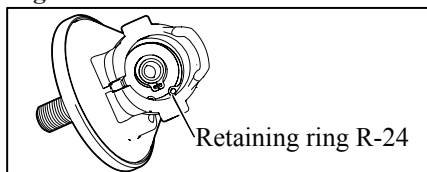

Fig. 17

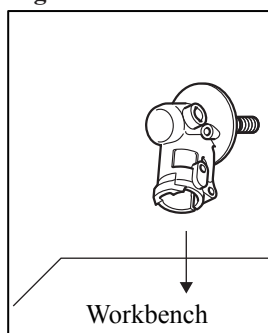

Fig. 18

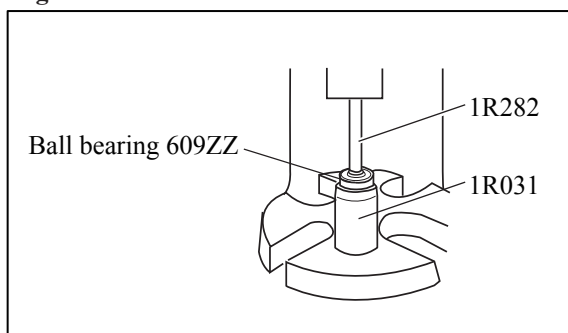

Fig. 19

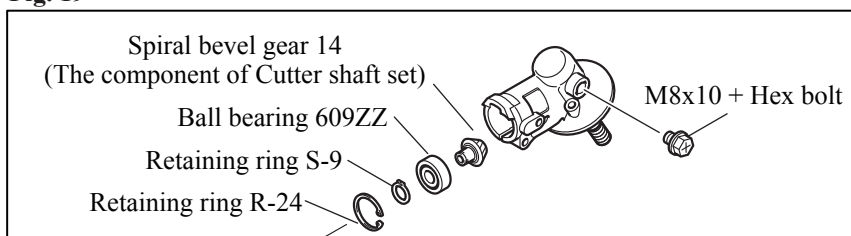

Fig. 20

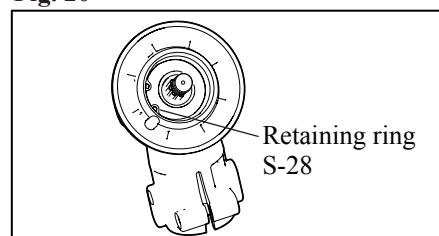

Fig. 21

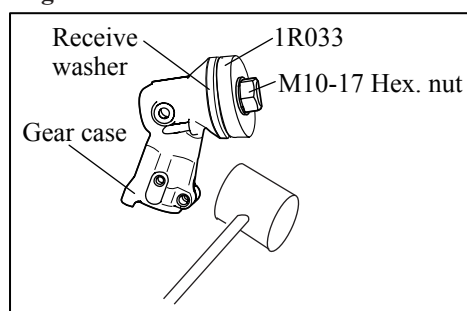
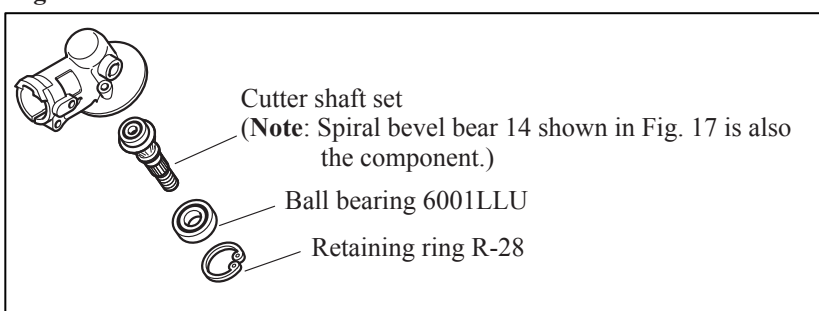

Fig. 22



ASSEMBLING

Assemble by reversing the disassembly procedure.

- Receive Gear case assembly with the U-shape table of Arbor press, then press down Ball bearing 6001LLU using 1R028 with Arbor press to insert Cutter shaft set in place. (**Fig. 23**)

Fig. 23

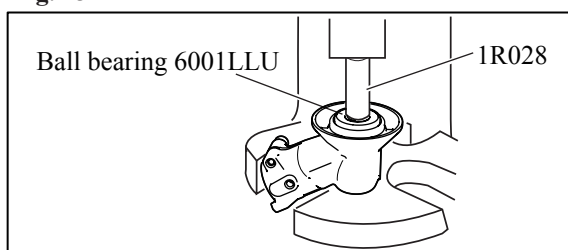

► Repair

[4] DISASSEMBLY/ASSEMBLY

[4]-6. Shaft pipe B complete

DISASSEMBLING

- (1) Remove two M5x25 Hex socket head bolts and Pipe clamp 24 from Shaft pipe B complete.
Clamp cover A, Pipe clamp 33 and Loop handle are removed. (**Fig. 24**)
- (2) Remove four 4x18 Tapping screws and two M5x14 Hex socket head bolts from Control lever assembly.
Control lever assembly is now separated to L and R. (**Fig. 25**)
- (3) Loosen M5x12 Hex socket head bolt and M6x25 Hex socket head bolt, and remove Joint 24 from Shaft pipe B complete. (**Fig. 26**)
- (4) Loosen M5x20 Pan head screw of Hanger set, and remove Hanger set itself and Spacer 24 from Shaft pipe B complete. (**Fig. 27**)
- (5) Pull out Shaft B complete from the pipe joint side of Shaft pipe B complete. (**Fig. 28**)
Remove Retaining ring S-12.

Fig. 24

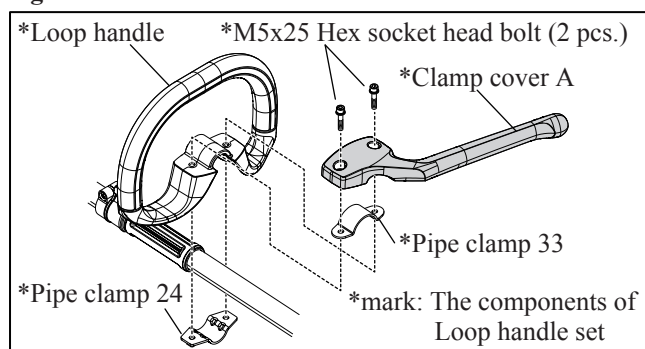

Fig. 25

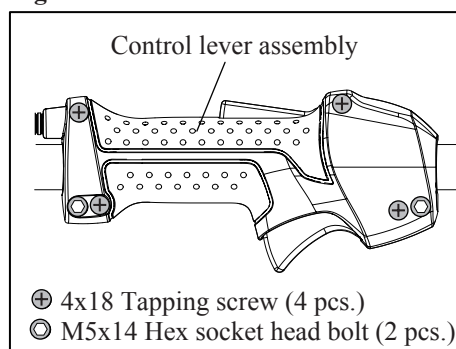

Fig. 26

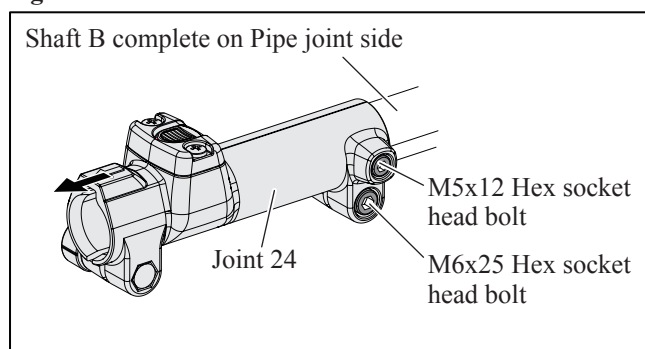

Fig. 27

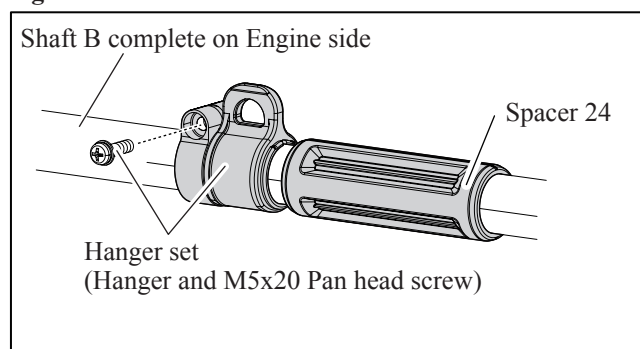
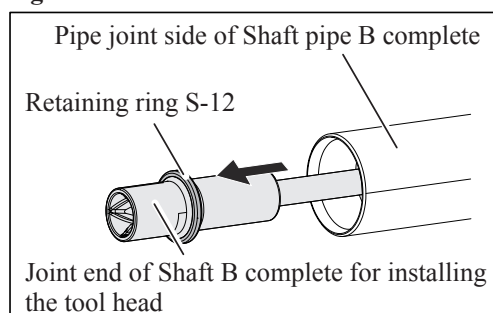

Fig. 28



ASSEMBLING

Assemble by reversing the disassembly procedure.

► Repair

[4] DISASSEMBLY/ASSEMBLY

[4]-6. Clutch drum

DISASSEMBLING

- (1) Remove Clutch case section from the engine.
- (2) Remove Retaining ring S-12 with 1R004 from clutch case section.
- (3) Remove Clutch drum from Clutch case section by pressing 1R247 with Arbor press. (**Fig. 29**)

ASSEMBLING

- (1) Put Clutch case on the table of Arbor press vertically, then press-fit the shaft of Clutch drum into the hole of Ball bearing 6201LLU with 1R286 and Arbor press as drawn in **Fig. 30**.
- (2) Set Retaining ring S-12 in place with 1R004.

Fig. 29

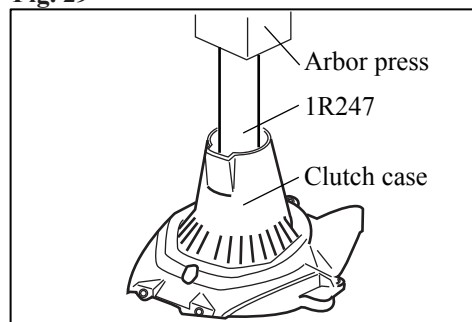
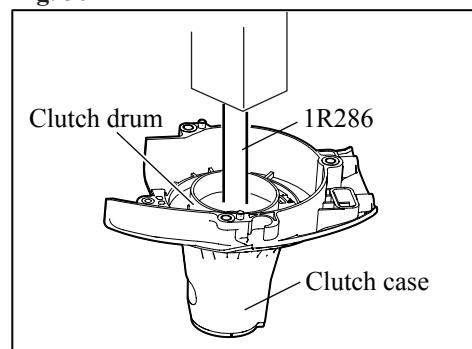

Fig. 30



[4] DISASSEMBLY/ASSEMBLY

[4]-7. Ignition

CHECK OF PLUG CAP

- (1) Remove Plug cap from Spark plug, then detect the continuity between Plug cap spring in Plug cap and Earth terminal of Ignition coil. It is the normal condition when Tester shows $2.0k\Omega \pm 0.5k\Omega$. (**Fig. 31**)
- (2) In case of no continuity or unstable continuity, check the connection between Plug cap spring and Ignition coil as follows:
 - (A) Spray the lubricant in Plug cap, then pull out Plug cap spring together with Ignition cable using Long-nose pliers. (**Fig. 32**)
 - (B) In case no connection or inconsistent connection, then check the condition of Plug cap and spring. Reassemble them or replace them if they are disorder.
 - (C) Insert the end of Plug cap spring into Ignition cable then return them back to the inside of Plug cap carefully so as not to be disconnected.
 - (D) Check Plug cap and spring again according to the step of (1) to avoid poor connection causing the poor sparks of Spark plug.

Fig. 31

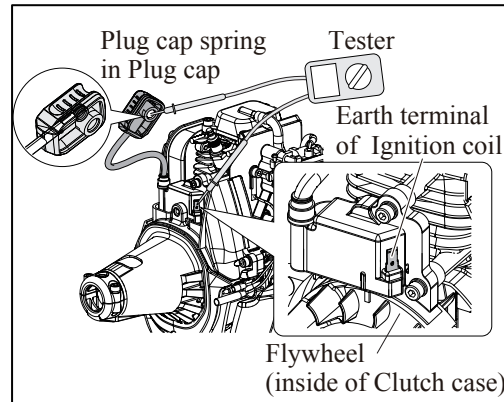
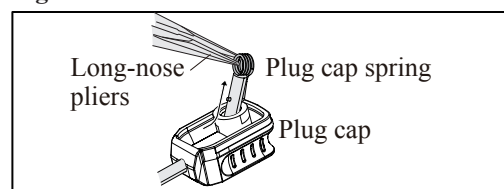

Fig. 32



CHECK OF SPARK PLUG

- (1) Remove Plug cap with Plug cap spring, then remove Spark plug with Socket wrench 16-17 (standard equipment).

Note: When the spark area is wet with Fuel, wipe it away with a cloth and dry it by air blow.
- (2) Clean carbonized materials on Insulated part for sparking with a wire brush.
- (3) Do fine adjustment of Spark plug as drawn in **Fig. 33**.
Insert 0.7mm thickness gauge of 1R366 to the clearance and adjust the leg of Spark plug carefully.
- (4) Install Plug cap with Plug cap spring on Plug and connect the plug screw part to a metal part of Engine, then pull Starter rope slowly. The sparks can be seen when starter rope is pulled.
- (5) When the sparks can not be seen, try [CHECK OF PLUG CAP] to detect the continuity. If required, replace Plug and recheck the sparks through the above process.

Fig. 33

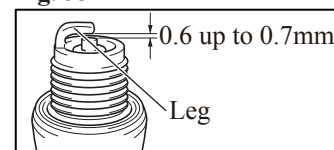

► Repair

[4] DISASSEMBLY/ASSEMBLY

[4]-7. Ignition (cont.)

DISASSEMBLING OF IGNITION COIL

See Fig. 34.

- (1) Remove Cylinder cover and cable from Ignition coil terminal.
- (2) Loosen two M4x20 Hex socket head bolts and remove Ignition coil from Engine.

Note: Do not lose two spacers on the bolts as the heat protection.

ASSEMBLING OF IGNITION COIL

See Fig. 35.

- (1) While attaching 0.3mm thickness gauge of 1R366 to the magnet portion of Flywheel, set Ignition coil in place.

Note: Two M4x20 Hex socket head bolts (Fig. 34) are with threadlocker. Therefore, when re-using them, apply ThreeBond 1342 or Loctite 242 to the threads.

- (2) After setting Ignition coil, remove the thickness gauge then turn Flywheel by hand to check if it turns smoothly without being stuck.

Note: Be sure to insert Spacer on M4x20 Hex socket head bolt when fastening Ignition coil to Engine. (Fig. 34)

- (3) Assemble Cylinder cover to Engine.

[4]-8. Flywheel

DISASSEMBLING

Note: • Flywheel can be easily removed without holding the piston.

- Do not remove Spark plug as compressed air resistance has to be used for the disassembling.
- Plug cap with Plug cap spring has to be removed from Spark plug to prevent Engine from running. (Fig. 31)

- (1) Turn M8 Flange nut in the center of Flywheel counterclockwise using Cordless impact driver with 13mm Socket bit. (Fig. 36)
- (2) Install 1R364 on Flywheel then screw two M6 bolts into Flywheel as drawn in Fig. 37 instead of M6x25 shoulder hex bolts. Flywheel is removed from Engine.

Important: Screw two M6 bolts evenly.

Fig. 36

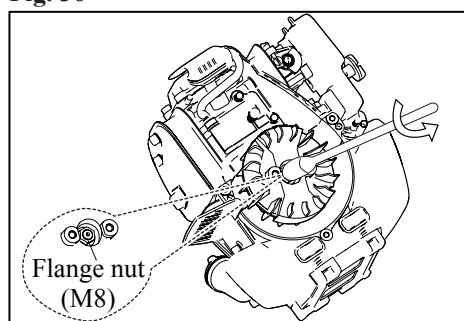
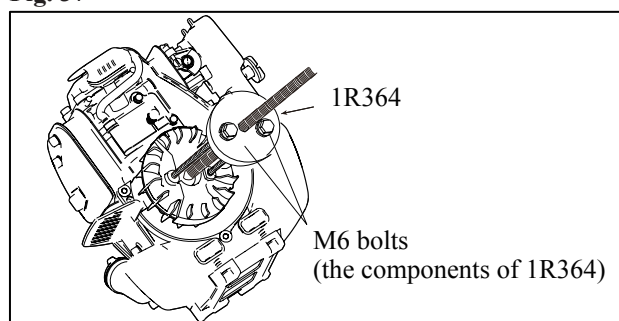

Fig. 37



ASSEMBLING

- (1) Wipe off the grease and oil from Crank shaft. (Fig. 38)
- (2) Put Woodruff key 3 into Crank shaft, then align the key groove of Flywheel to the crank shaft with the key. (Fig. 38)
- (3) Screw M8 Flange nut to the thread of Crank shaft by turning the nut clockwise by hand.
- (4) Tighten M8 flange nut about two seconds using Cordless impact driver with 13mm socket bit.

Fig. 38

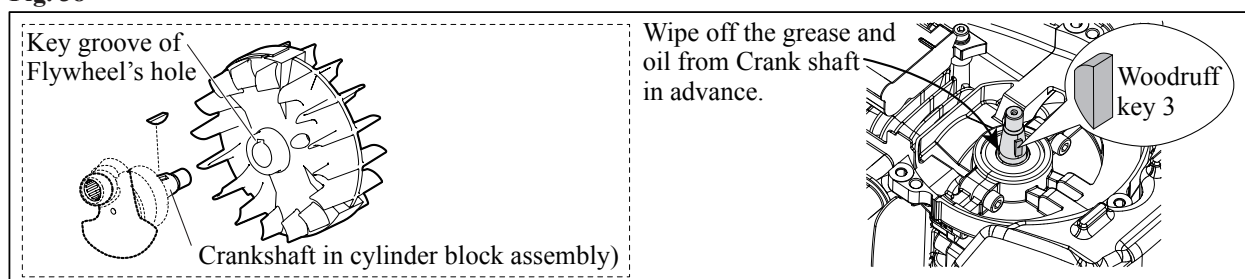

Fig. 34

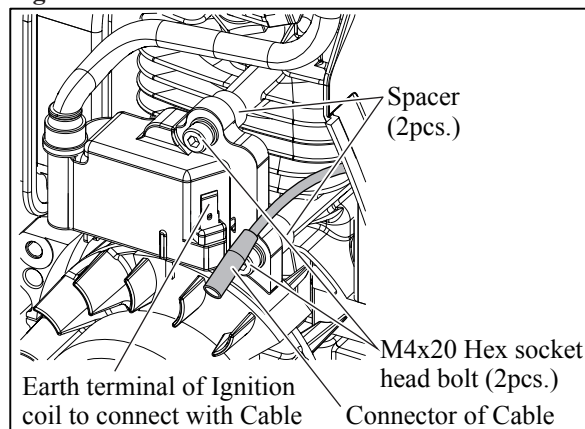
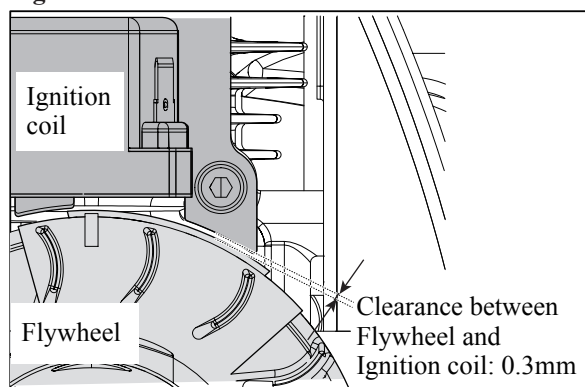

Fig. 35



► Repair

[4] DISASSEMBLY/ASSEMBLY

[4]-9. Recoil starter

DISASSEMBLING

- (1) Remove Starter case from Engine.
- (2) Pull out and cut the rope when it is still connected.
If it is impossible to cut Starter rope;
First, pull the rope one turn of Reel, then, Hook the rope with the notch of Reel and turn the hooked rope clockwise until Spiral spring loses the tension. (Fig. 39)
Note: Be careful. Reel is revolved by the recoil force of Spiral spring.
- (3) Loosen M5x12 Tapping screw and remove Swing arm and Reel from Starter case. (Fig. 40)
Note: Be careful when removing this screw as there is a possibility that Spiral spring pops out.
- (4) Untie the knot of the rope in Reel and remove the rope from Reel.

ASSEMBLING

- (1) When Spiral spring pops out of Reel:
 - Set the one end of Spiral spring in the slot outer side in the Reel.
 - Rewind the spring counterclockwise toward the center of circle and fit the spring end in the slot inside of Reel. (Fig. 41)
- (2) Apply a little amount of Makita grease N No.2 to the spring.
- (3) Make a knot on the new rope end and pass it through Reel and Starter case, then, connect the other end to Starter knob. (Fig. 42)
Refer to Fig. 43 how to make a knot of the rope.
- (4) Wind the rope two or three turns.
- (5) While turning Reel counterclockwise, fit it into Starter case and hook Spiral spring end on the rib inside of Starter case. (Fig. 44)
Note: This should be fixed without force.
- (6) Set Collar and Swing arm in place, then secure them with M5x12 Tapping screw. (Fig. 45)
Swing arm has to be passed through the groove of Reel.
Important: In case Reel turning is not smooth after tightening M5x12 Tapping screw, Reel is not properly fixed to Starter case. Repeat the step (5) so that Reel can revolves smoothly even after M5x12 Tapping screw is completely tightened.
- (7) Hook the rope in the notch of Reel while straining the rope, then, turn reel counterclockwise. (Fig. 46) When the rope is removed from the notch, the Reel winds the rope with spring recoil force. Repeat the step until the rope slacks are cleared.

Fig. 39

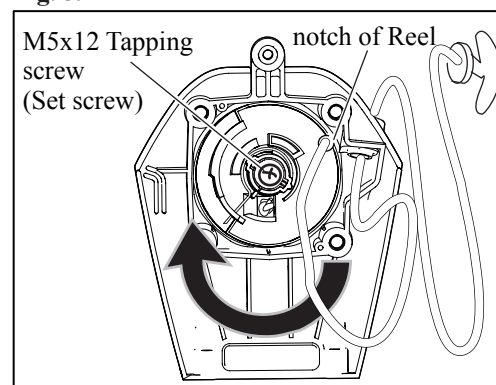

Fig. 40

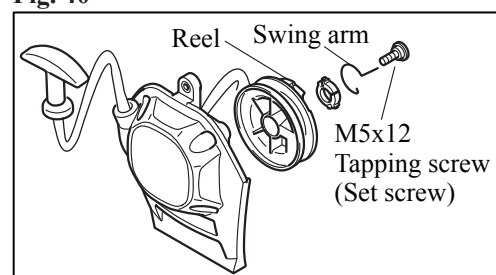

Fig. 41

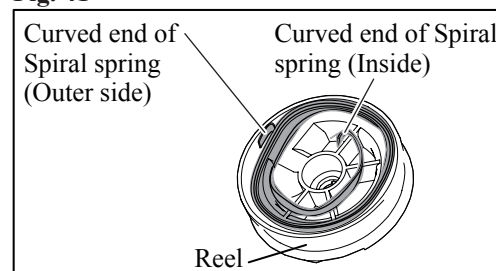

Fig. 42

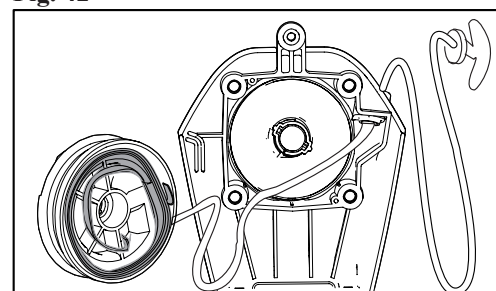

Fig. 43

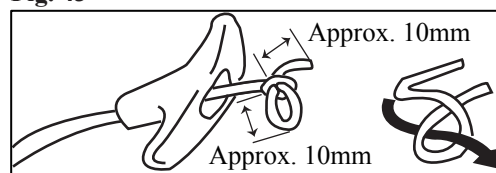

Fig. 44

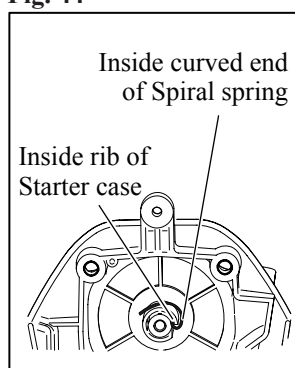

Fig. 45

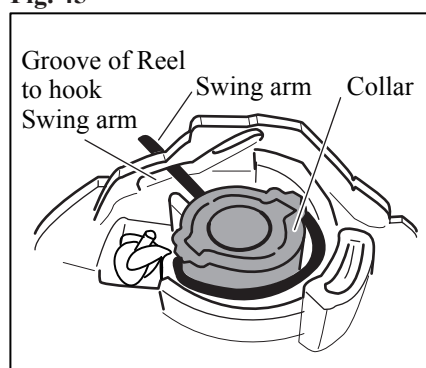
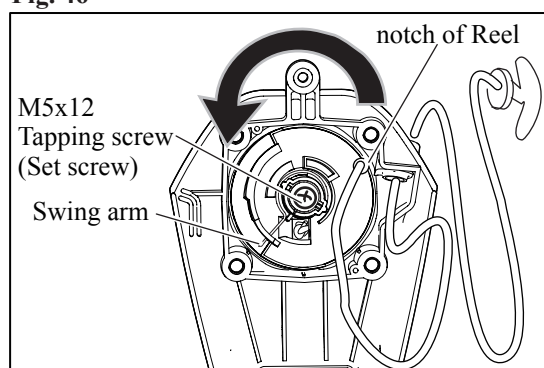

Fig. 46



► **Repair**

[4] DISASSEMBLY/ASSEMBLY

[4]-10. Carburetor

DISASSEMBLING

- (1) Remove Cleaner cover assembly by unscrewing M4 Thumb screw. (Fig. 47)
 - (2) Remove two Air cleaner elements. (Fig. 48)
 - (3) Remove two M5x60 Hex. socket head bolts for fastening Carburetor and Cleaner plate assembly to Insulator. (Fig. 48)
- Note:** Carburetor can not be removed without removing the bolts completely.
- (4) Disconnect two tubes from Carburetor, then remove Carburetor.

Fig. 47

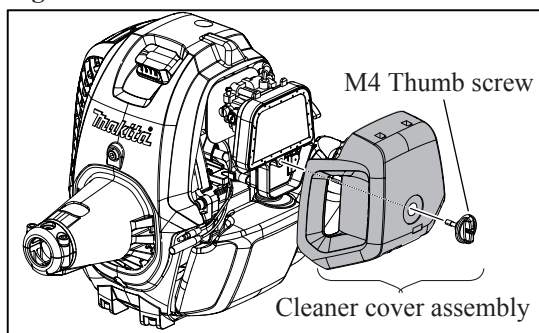
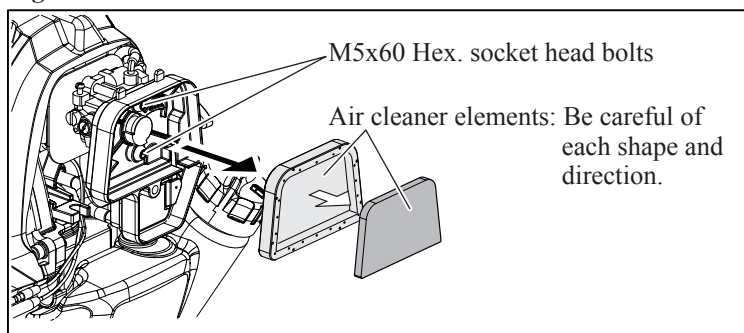

Fig. 48



CLEANING / MAINTENANCE

Refer to Fig. 49.

- (1) Remove four 3x24 Tapping screws, then separate Metering diaphragm and Metering diaphragm gasket.

Note: In case Metering diaphragm remains attached to the others in disassembling of Carburetor, be careful to remove Metering diaphragm and gasket. It is fragile.
- (2) Replace Metering diaphragm when the following problems happen:
 - slackened
 - hardened
 - worn / debased
- (3) Loosen M3x4 screw in Pump body to remove Inlet needle and Control lever etc. (Refer to Fig. 50) from Carburetor.
- (4) Before assembling Pump body, check that the top of Inlet needle is not deformed/ worn out. (Fig. 51).
- (5) When Control lever is set in place, make sure that Spring is put properly. (Fig. 52)
- (6) Regarding three M3x8 Pan head screws with washers, loosen Idling screw fully first, and then remove them.
- (7) After checking if Inlet screen is clogged with dust, fit it into Pump body.
- (8) Spray carburetor cleaner each route in Carburetor and then clean it with gasoline after a few minutes.

Fig. 50

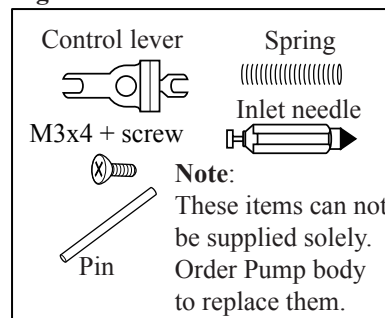

Fig. 49

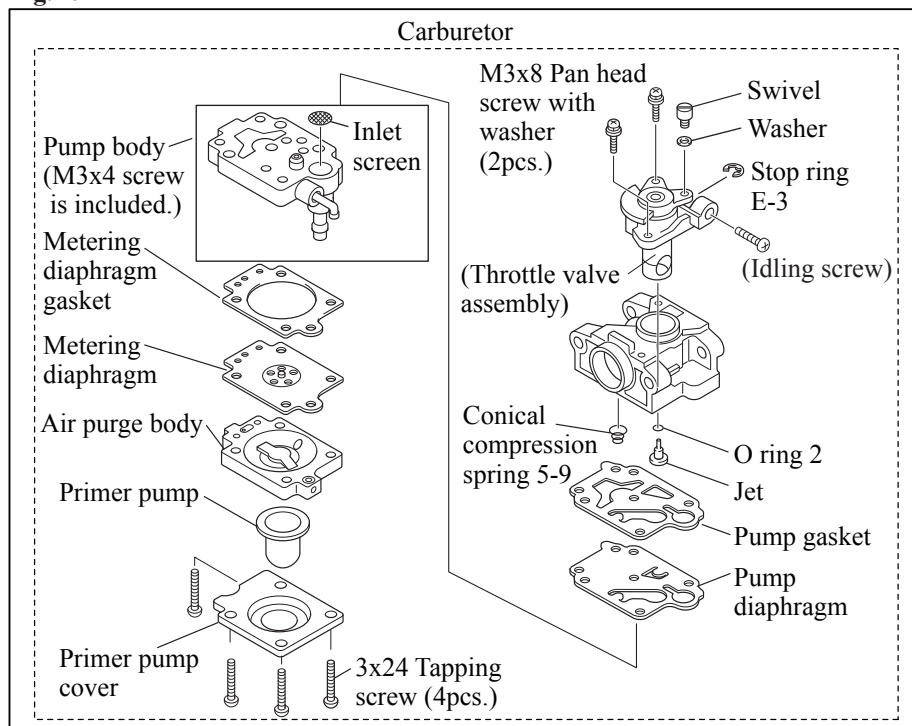

Fig. 51

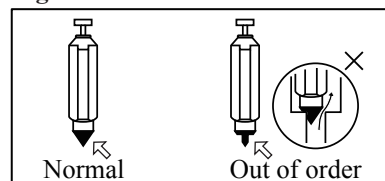
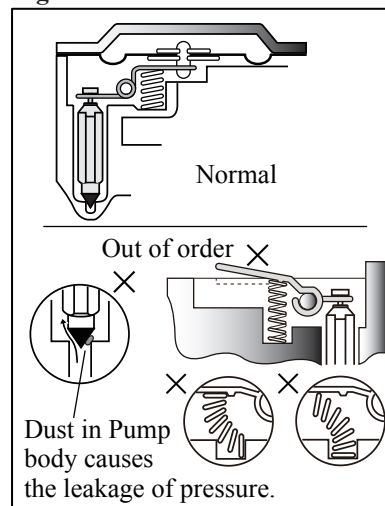

Fig. 52



► Repair

[4] DISASSEMBLY/ASSEMBLY

[4]-10. Carburetor (cont.)

ASSEMBLING

Carefully assemble each part in right direction and order.

TEST OF AIRTIGHT STRUCTURE

Connect 1R127 to the nipple of Carburetor as drawn in **Fig. 53**.
Give air pressure from 1R127 and check if the pressure gauge indicates 0.05Mpa for around 10 seconds, then, there is no problem with Carburetor.

ASSEMBLING TO ENGINE

- (1) Assemble Cleaner plate assembly, Carburetor and Gasket to Insulator with two M5x60 Hex socket head bolts.
- (2) Connect black tube of Fuel tank to the nipple of Carburetor. Connect yellow tube of Fuel tank to the other nipple of Carburetor. (**Figs. 53 and 54**)
Connect Tube from Cylinder and **Breather pipe** to the Cleaner plate assembly.
Note: Make sure that fuel tubes do not touch on Cylinder cover.
- (3) Set Air cleaner elements in place. The felt element is put on the bottom, and the sponge element is on the front.
- (4) Hook the tabs of Cleaner plate assembly with the holes of Cleaner cover assembly. (**Fig. 55**)

Fig. 53

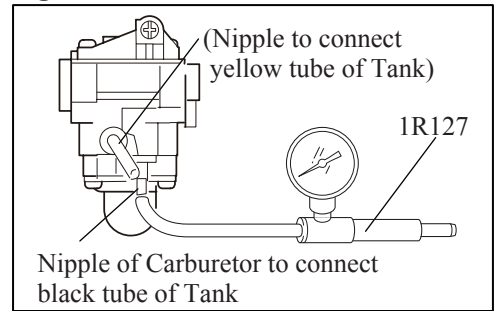

Fig. 54

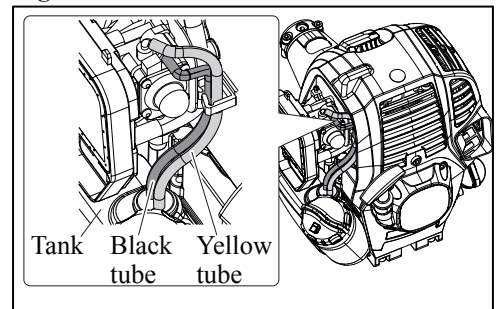
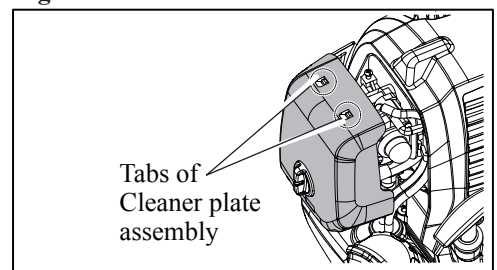

Fig. 55



[4]-11. Stop switch

Check the continuity of two Lead wires' ends routed from Control lever with Tester. (**Fig. 56**)

Fig. 56

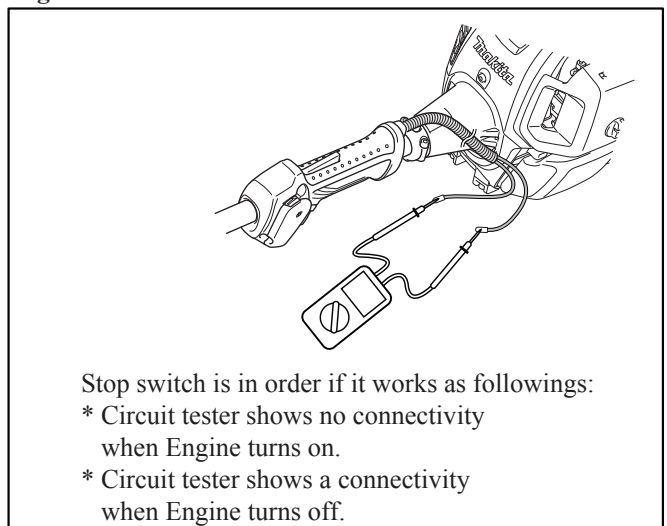

[4]-12. Fuel tube

Assemble Tube complete (Black tube, Yellow tube and Grommet) to Fuel tank as drawn in **Fig. 57**.
Assemble Gasoline filter and Hose clamp to the black tube, then put them into Fuel tank. (**Fig. 58**)

Fig. 57

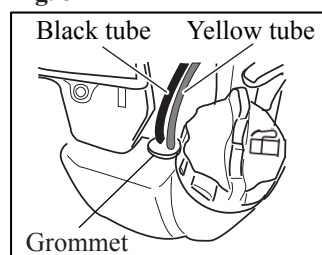
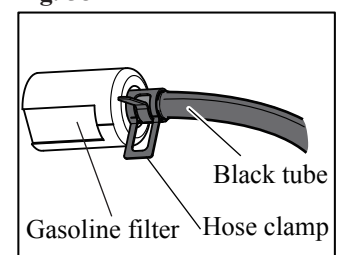

Fig. 58



► Repair

[4] DISASSEMBLY/ASSEMBLY

[4]-13. Spark arrester (Only for some countries, i.e., having dry atmospheres at high temperature)

MAINTENANCE

- (1) Remove Cylinder cover.
- (2) Remove Exhaust Muffler.
- (3) Remove Spark arrester from Exhaust muffler (**Fig. 59**).
Sweep it off if dirt or soot is on Spark arrester.
Replace it with a new one if spark arrester has a breakage or fray.
- (4) Assemble Spark arrester to Exhaust muffler.
- (5) Set Exhaust muffler in place.

Note: • Refer to Parts breakdown, and do not forget muffler gasket.

- Two M5x40 Hex socket head bolts on Exhaust muffler are threadlocker type.
Once removing them for repair, apply ThreeBond 1342 / Loctite 242 to the threads to screw them.

- (6) Set Cylinder cover in place.

Fig. 59

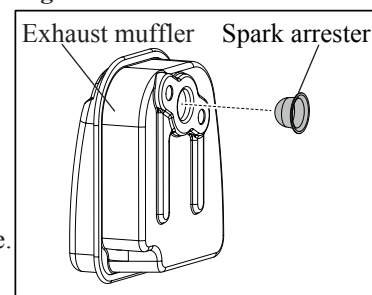

[4]-14. Engine block

DISASSEMBLING

- (1) Drain the oil from Engine as much as possible so that the remaining oil is not spilled out when disassembling.
- (2) Remove the following parts from Engine.
 - Cylinder cover • Tank guard • Fuel tank • Clutch case
 - Recoil starter assembly • Clutch • Ignition coil • Flywheel
 - Rocker cover inner • Rocker cover gasket • Rocker arm assembly
 - Rod 2.5 • Cam lifter • Cam gear • Insulator • Air cleaner • Carburetor
 - Spark plug • Muffler
- (3) Open Cylinder block by removing six M5x16 Hex socket head bolts. (**Fig. 60**)
- (4) Remove Clips from both ends of Piston pin hole with the awl. (**Fig. 61**)
Note: • Be careful as the clip pops out.
• Do not reuse the removed Piston clip.
- (5) Remove Piston pin by pushing it with 1R171. (**Fig. 62**)
- (6) Piston can be now removed from Crankshaft.

Fig. 60

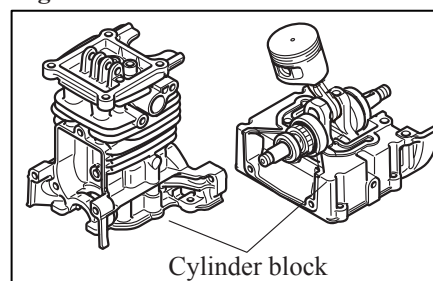

Fig. 61

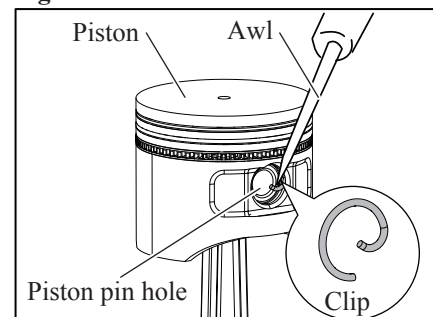
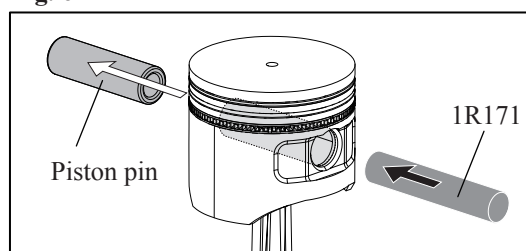

Fig. 62



► Repair

[4] DISASSEMBLY/ASSEMBLY

[4]-14. Engine block (cont.)

ASSEMBLING

(1) Piston can be assembled in either direction.

Apply Makita grease N No. 2 to the needle bearing of Crank shaft assembly in advance.

(2) Insert Piston pin through Piston and Crank shaft, and fix it with Clips by using the awl (Clip has no direction).

(3) Piston rings have their directions and each different shapes as drawn in **Fig. 63**.

First, install Piston ring 34, and next, install Piston ring (second) 34, then finally install Piston ring (top) 34.

The piston ring 34 for the lowest groove on Piston consists of three part; top ring, middle ring and bottom ring.

Top ring and bottom ring have a clearance and the distance of each clearance point must have 120° angle.

Piston ring (top) 34 and Piston ring (second) 34 consist of single part and the distance between their clearances must have 180° angle when they fixed into the grooves on the piston.

Note: Piston rings are easy to break. Do not enlarge them too much when fixed.

(4) Assemble Cylinder block assembly.

After removing grease from the matching surface of Cylinder block and Crank case (Refer to **Fig. 64**), apply ThreeBond 1216 on the Crank case side.

Note: The layer of ThreeBond 1216 has to be thin so as not to enter into the oil route in Engine and get clogged.

Apply 4-stroke oil to the contact surface of Piston and Cylinder.

While holding Piston rings, install the assembled part of Piston into Cylinder block.

(5) Fasten Cylinder block assembly by tighten the screws in crisscross pattern.

Fig. 63

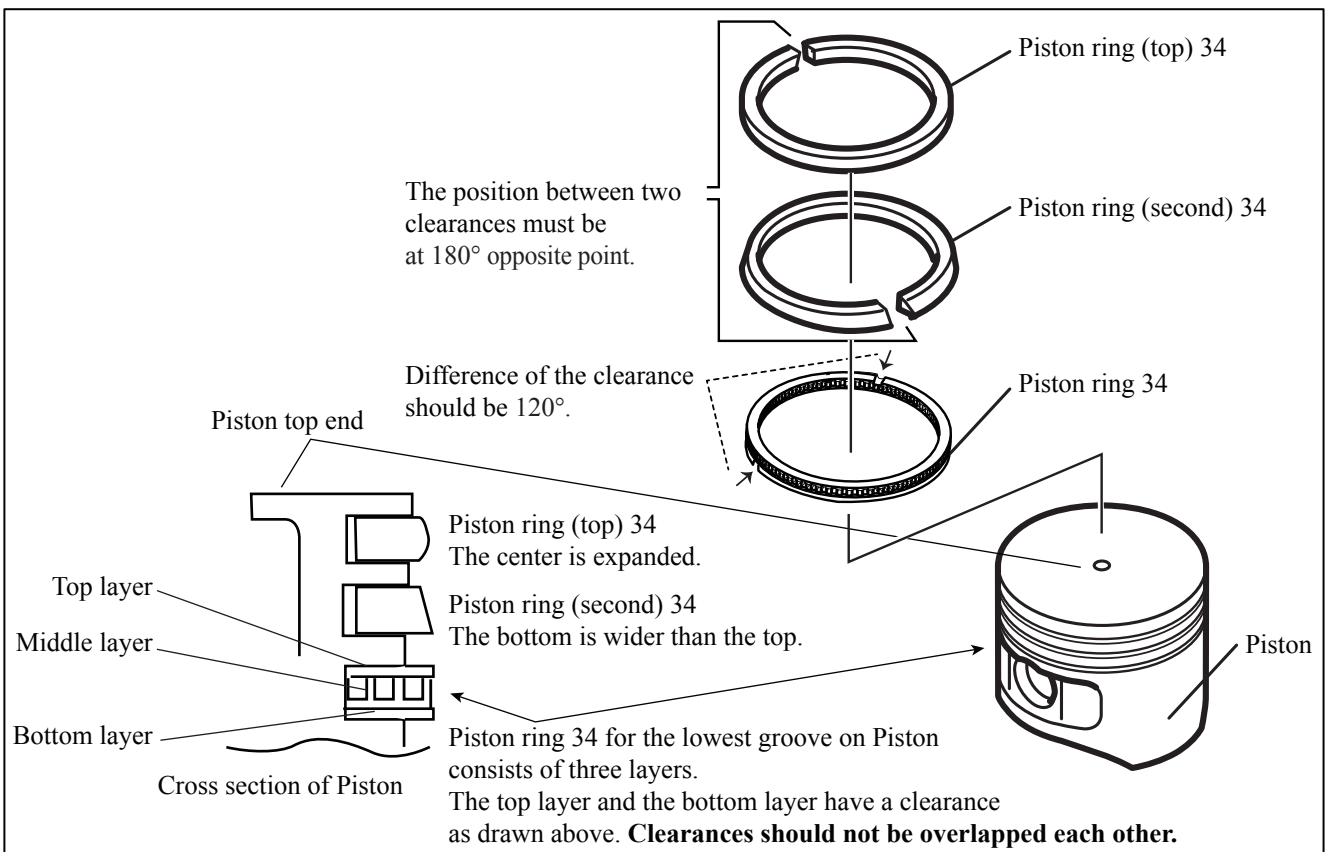
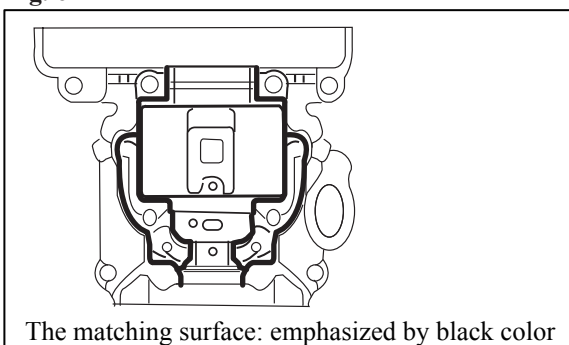

Fig. 64



► Repair

[4] DISASSEMBLY/ASSEMBLY

[4]-14. Engine block (cont.)

ASSEMBLING

(6) Adjust the valve clearance as follows:

- Align the marking on Flywheel with the marking on Ignition coil. (**Fig. 65**)
- Align the marking on Cam gear assembly with the marking on Cylinder block. (**Fig. 66**)
- Assemble two Cam lifters and two Rod 2.5, and then assemble two Rocker arm assembly to them.
Note: The ends of Rod 2.5 have to be put into the round depressions of Cum lifter and Rocker arm.
- Loosen the adjust screws of Rocker arm assembly, and put 0.1mm thickness gauge of 1R366 between Valves and Rocker arms.
Then adjust the valve clearance. (**Fig. 67**)
- After the adjustment, tighten the nuts of Rocker arm assembly, remove 0.1mm thickness gauge of 1R366.

Fig. 65

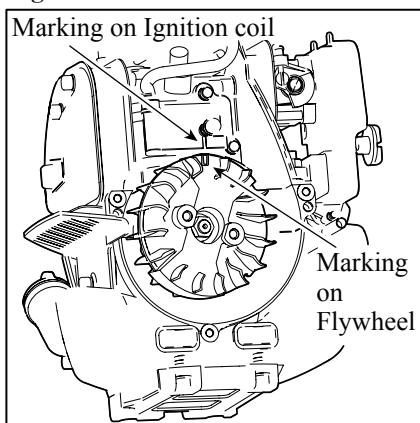

Fig. 66

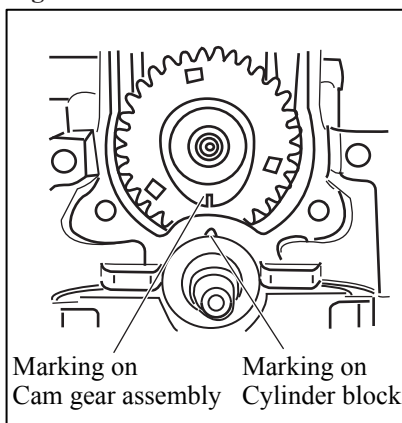
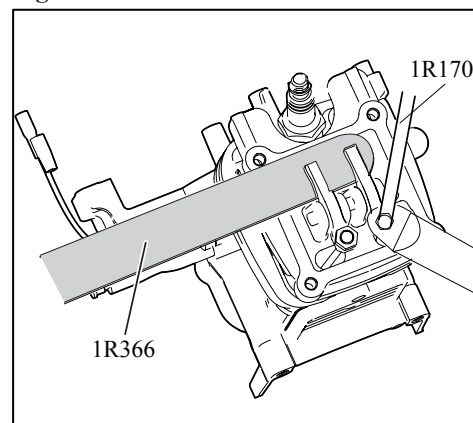

Fig. 67



[4]-15. Fastening torque

Fig. 67

Parts to fasten	Screw/ Nut	Fastening torque (N·m)
CYLINDER BLOCK and CRANK CASE	HEX SOCKET HEAD BOLT (M5×16)	6.0
CRANK CASE and RETAINER PLATE	HEX SOCKET HEAD BOLT (M4×10)	3.0
CRANK CASE and OIL CASE	HEX SOCKET HEAD BOLT (M5×16)	6.0
FLYWHEEL and CRANK SHAFT 1	FLANGE NUT (M8)	16.0
COIL and CYLINDER BLOCK	HEX SOCKET HEAD BOLT (M4×20, W, SW, MEC)	4.0
CAM GEAR COVER and CYLINDER BLOCK	HEX SOCKET HEAD BOLT (M5×16)	6.0
ROCKER ARM ADJUSTING SCREW and NUT	NUT (M5)	6.0
ROCKER COVER OUTER and CYLINDER BLOCK	HEX SOCKET HEAD BOLT (M5×16)	6.0
CLUTCH and FLYWHEEL	CLUTCH BOLT (M6×25)	9.0
MUFFLER and CYLINDER BLOCK	HEX SOCKET HEAD BOLT (M5×40,W,MEC)	8.0
SPARK PLUG and CYLINDER BLOCK	M10×P1.0	11.0
INSULATOR and CYLINDER BLOCK	HEX SOCKET HEAD BOLT (M5×18,W,SW)	5.0
CLUTCH CASE and CYLINDER, CRANK CASE	HEX SOCKET HEAD BOLT(M5×18,W,SW)	5.0
PULLEY and CRANK SHAFT 2	M8	6.0
RECOIL STARTER and CYLINDER, CRANK CASE	HEX SOCKET HEAD BOLT (M5×16,W,SW)	5.0
MUFFLER PLATE and CRANK CASE	HEX SOCKET HEAD BOLT (M5×14,W,SW)	5.0
OIL PIPE and OIL CASE	HEX SOCKET HEAD BOLT (M5×14,W,SW)	5.0
CASE, GEAR ASSEMBLY and PIPE SHAFT	HEX SOCKET HEAD BOLT (M5×25,SW)	7.0
CASE, GEAR ASSEMBLY and PIPE SHAFT	HEX SOCKET HEAD BOLT (M5×14,SW)	7.0
HANDLE HOLDER 2, 3 and PIPE SHAFT	HEX SOCKET HEAD BOLT (M5×30,SW)	6.0
CONTROL LEVER and HANDLE	SCREW PAN HEAD (M4x25,W,SW)	2.0
BRACKET PIPE and SHAFT PIPE COMPL	HEX SOCKET HEAD BOLT (M5×18,SW)	5.0
BRACKET PIPE and SHAFT PIPE COMPL	HEX SOCKET HEAD BOLT (M5×12,SW)	5.0
CONTROL CABLE and INSULATOR	NUT (M6)	2.0
JOINT 24 and LEVER 94	NUT (M6)	7.0
JOINT 24 and PIPE SHAFT B	HEX SOCKET HEAD BOLT (M5×12)	4.0
JOINT 24 and PIPE SHAFT B	HEX SOCKET HEAD BOLT (M6×25)	4.5

Free Manuals Download Website

<http://myh66.com>

<http://usermanuals.us>

<http://www.somanuals.com>

<http://www.4manuals.cc>

<http://www.manual-lib.com>

<http://www.404manual.com>

<http://www.luxmanual.com>

<http://aubethermostatmanual.com>

Golf course search by state

<http://golfingnear.com>

Email search by domain

<http://emailbydomain.com>

Auto manuals search

<http://auto.somanuals.com>

TV manuals search

<http://tv.somanuals.com>