

Subject ▶ Modifications on Tool Holder

For Models ▶ HM0810, HM810B, HM0810T, HM0811, HM0821

Country ▶ All countries

Description ▶ As illustrated below;

- 1) Flat Washer 43 (Part No.267203-1) has been added as illustrated below in order to fasten Tool Holer on Barrel Complete straightly with further accuracy.
- 2) The adhesive, Three Bond 1342 has been added on three spots of the thread of Tool Holder as illustrated below to prevent Tool Holder from loosening.
- 3) In accordance with the modifications of 1) and 2), Tool Holders / Tool Holder Assemblies for repairing of the subject Models have been changed to Tool Holder Sets. These Tool Holder Sets additionally include each one piece of Flat Washer 43 (Part No.267203-1) and O ring 38 (Part No.213508-7), which might necessarily be replaced whenever Tool Holders / Tool Holder Assemblies are replaced in repairing. See the column of Interchangeability for Part Nos. of Tool Holder Sets.

Where Flat Washer 43 Is Placed and Three Bond 1342 Is Applied

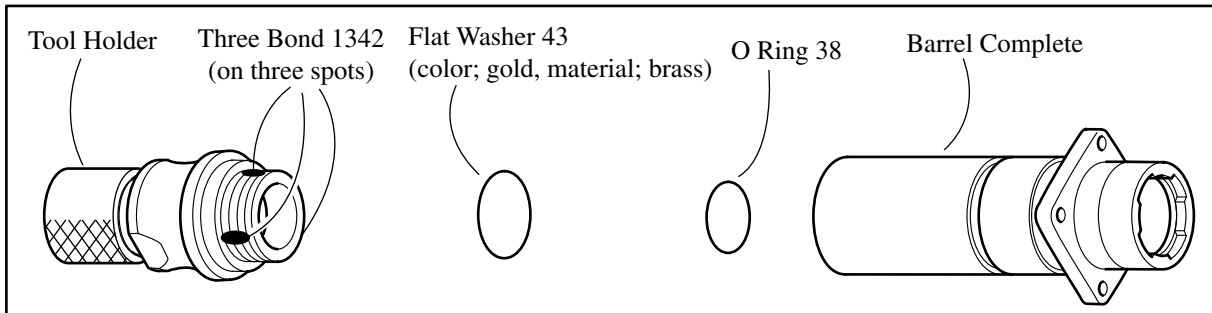

Note)

See the next page for "Service Manual for Tool Holders of Models HM0810/HM0810B/HM0810T" that we have newly issued, taking these modifications into account.

Interchangeability(I/C)

| Item No. | Current part | Q'ty | I/C | New part | Q'ty | Note |
|---|-------------------------------|------|-----|-----------------------------------|------|-------------------------------|
| | ----- | | | Three Bond 1342(50g) 045017-6A | 0.1g | For all Models |
| HM0810: 093 HM0810B: 086 HM0810T: 081 HM0811: 095 HM0821: 090 | ----- | | | Flat Washer 43 267203-1 | 1 | For all Models |
| HM0810: 034 HM0811: 036 HM0821: 034 | Tool Holder 322594-8 | 1 | ← | Tool Holder Set 193003-2 | 1 | ↑ HM0810, HM0811 HM0821 |
| HM0810, HM0811, HM0821: 500 | Tool Holder Ass'y 134716-6 | 1 | ← | Tool Holder Set 193010-5 | 1 | ↓ |
| HM0810B: 031 | Tool Holder 323790-1 | 1 | ← | Tool Holder Set 193005-8 | 1 | HM0810B |
| HM0810T: 032 | Tool Holder Ass'y 125070-9 | 1 | ← | Tool Holder Set 193004-0 | 1 | HM0810T |

Note

Interchangeability mark ; ← means that the new part is substituted for the current.

Implementation

HM0810 : From serial No.405169E (May,1999)

HM0810B : From serial No.37902E (May,1999)

HM0810T : From serial No.57443E (May,1999)

HM0811 : Discontinued since Apr.,1989

HM0821 : Discontinued since June,1991

Service Manual for Tool Holders of Models HM0810/ HM0810B/ HM0810T

When re-securing Tool Holder in repairing, always take the steps of procedure as described below.

1) How to Remove Tool Holder

(a) Hold the machine tightly with a vise as in Fig.(1).

(b) Insert a hex.wrench (size: 17mm between the opposite sides) into the hex. socket of Tool Holder, and loosen it with a pipe of one meter long.

(Notes)

1. When the hex. socket of Tool Holder is broken, use a pipe wrench to grip Tool Holder directly and to loosen it.
2. When Tool Holder cannot be loosened, heat it with a gasburner .
In case of damaging O Ring 38 and/or X Ring at the time, sure to replace them with new ones.

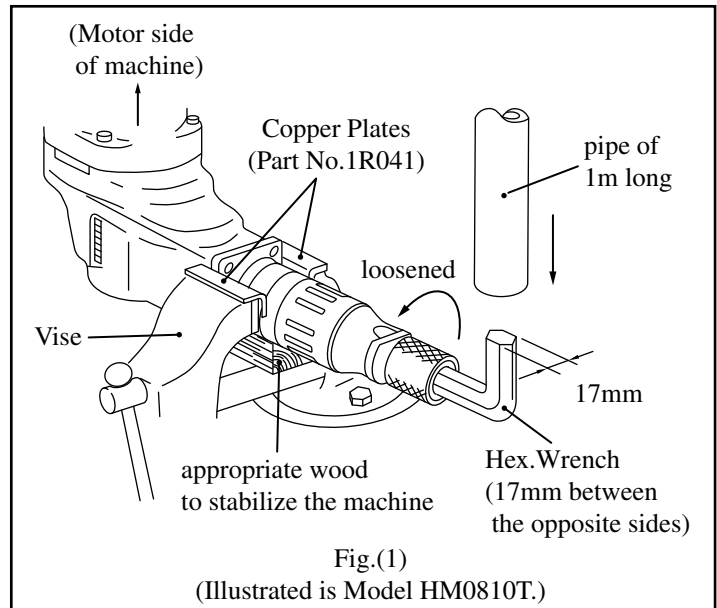

2) How to Fasten Tool Holder on Barrel Complete

(a) As illustrated in the former page, set Flat Washer 43 (Part No.267203-1) in place and apply adhesive on the three spots on the thread of Tool Holder. And then, secure Tool Holder by taking the reverse steps of procedure of Removing as described above.

(Notes)

1. Replace Flat washer 43 with new one in every repairing because the washer is pressed and deformed every time Tool Holder is secured.
2. Although the recommendable adhesive is Three Bond 1342 (Part No.045017-6A), you may also use any type of adhesive that is available for oily surface.

(b) Fasten Tool Holder on Barrel Complete with torque of 250Nm or over - that is, as in Fig.(2), give weight of 25kg or over to the end of one meter pipe after securing Tool Holder till the pipe comes to the horizontal position.

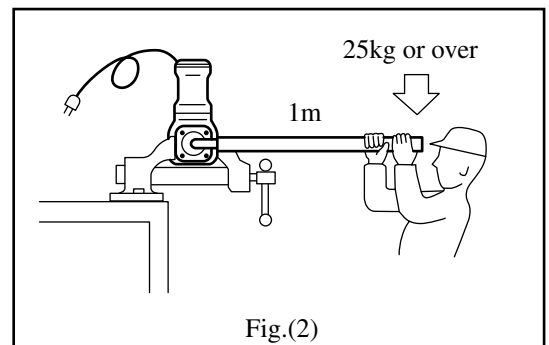

(c) How to Adjust the Position of Tool Holder;

HM0810 - to see Fig.(3);

Secure Tool Holder till the side plate of Tool Retainer comes parallel with the side of square foot of Barrel Complete.

HM0810B - to see Fig.(4);

Secure Tool Holder till the end side of Bolt-type of Tool Retainer comes parallel with the side of square foot of Barrel Complete.

HM0810T - to see Fig.(5);

Secure Tool Holder till two opposite sides of the hex. socket of Tool Holder comes parallel with the two sides of square foot of Barrel Complete as in the right illustration of Fig.(5).

At this time, Tool Holder should be secured till "Z" comes to "A" as in the left illustration of Fig.(5).

However, when "Z" has already passed "A", sure to secure Tool Holder till "Y" comes to "A".

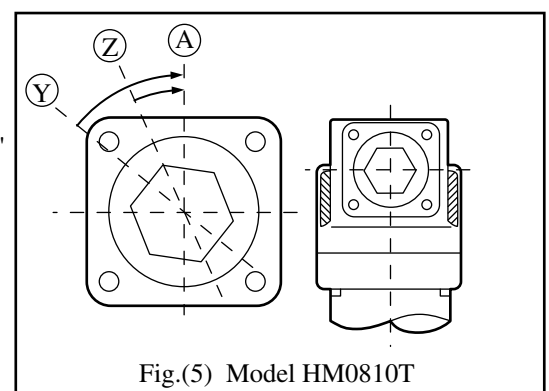
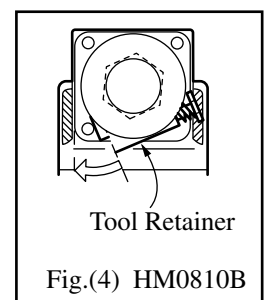
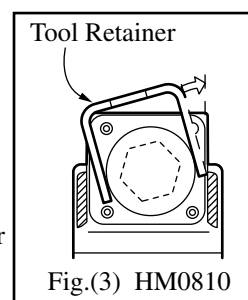

Free Manuals Download Website

<http://myh66.com>

<http://usermanuals.us>

<http://www.somanuals.com>

<http://www.4manuals.cc>

<http://www.manual-lib.com>

<http://www.404manual.com>

<http://www.luxmanual.com>

<http://aubethermostatmanual.com>

Golf course search by state

<http://golfingnear.com>

Email search by domain

<http://emailbydomain.com>

Auto manuals search

<http://auto.somanuals.com>

TV manuals search

<http://tv.somanuals.com>