

Instructions

Mamiya 7 II

READ ME FIRST

The camera is shipped with the light shield curtain in the open position.

Therefore you cannot remove the body cap unless you close the curtain first.

Please read page 10 of the instruction book first.

The camera will not function without a battery. Please read pages 8 and 9 next.

You will want to practice with the camera without film. This can be done in two ways. Either leave the back cover open or set the Multi Exposure Lever to Multi.

The instruction book was written for the black finished camera. Subsequently a silver model was added. The white index marks and dots on the black model appear in black on the silver model.

Congratulations on your purchase of the Mamiya 7II and welcome to the world-wide family of happy Mamiya camera owners !

Mamiya pioneered the 6x7cm medium format SLR system camera when it introduced the first Mamiya RB67 in 1970. In 1982 an additional model followed, the Mamiya RZ67 with electronic features.

Both cameras soon became the market leaders and the preferred tool of trade for portrait, commercial and magazine photographers all over the world and established the 6x7 rectangular image as the "ideal format".

Now we are proud to present the Mamiya 7II, 6 x 7cm rangefinder camera.

Reflecting Mamiya's traditional quality workmanship plus modern design, the Mamiya 7II is compact and lightweight. It offers the handling ease of a 35mm camera, while yielding far superior 4.5 times larger images. Featuring interchangeable, rangefinder coupled lenses and AE metering, it also permits taking 24 x 65mm panoramic images on 35mm film, by means of an optional adapter kit.

The Mamiya 7II lens program includes a standard 80mm lens, a 50mm and 65mm wide angle lens, an ultra-wide 43mm lens and a 150mm telephoto lens.

The Mamiya 7II and its lenses have undergone extensive quality controls at every step of manufacture. Please read this instruction manual thoroughly before you use the camera. A proper understanding of all its features and functions will eliminate potential misuse and ensure a long service life.

Contents

Mamiya 7II, the ultimate 6x7 rangefinder camera	3
Nomenclature Parts	4
Camera Body	4
Lens	6
Viewfinder display	7
Inserting Battery	8
Power ON/OFF and Shutter Release Button	8
Battery Check	9
Mounting/Removing Lenses	10
Closing the light shield curtain	10
Removing camera body cap	10
Mounting lens	11
Removing lens	12
Precaution for mounting/removing lenses	13
Camera Functional Test	14
Before Loading the Film	15
Setting the film speed	15
Opening/closing the back cover	15
Setting the film type	16
Memo clip	16
Loading the Film	17
Taking Photographs	20
AE (Automatic Exposure) Photography	20
Manual Photography	22
Focusing the Lens	24
Photographic area covered	25
Unloading the film	27
Photographing to conform to purposes	28
AE Lock(AEL) Photography	28
Self-Timer	29
Time Exposures	30
Flash Photography	31
Multiple exposure mechanism	32
Infrared Photography	32
Exposure Compensation	33
Diopter Correction Lenses	34
Depth-of-Field	34
How to Hold the Camera	35
Neck strap	35
Troubleshooting	36
Lenses	37
Accessories	39
System chart	40
Specifications	41
Common Sense Camera Care and Practice	42

Mamiya 7II, the ultimate 6x7 rangefinder camera

The Mamiya 7II is the only camera in the world that has these exclusive features:

- Ideal 6x7cm film format that enlarges to standard photographic and industrial paper sizes without cropping and without wasting film. A size that can be viewed with the naked eye and that is easy to retouch.
- Lightweight, compact, "quick on the draw" and ergonomically designed to fit in your hand like a glove.
- Crisp, accurate, broad based, split-image rangefinder, that is easy to focus, even in poor light.
- Bright viewfinder with frame lines that are automatically indexed to match the focal length of lens in use and that automatically adjust for parallax.
- Interchangeable, world-class Mamiya lenses, utilizing the latest optical glasses and computer aided design and that take advantage of the camera's short flange focal distance (there is no mirror box) to reach new
- Precision, super quiet, electronic shutter with speeds from 4 to 1/500 sec., flash synchronized at all speeds.
- Built-in "dark slide" curtain that permits changing lenses with film in camera.
- Precision AE (automatic exposure) meter with manual overrides.
- Self-timer (delayed action release) with automatic turn-off.
- Optional external battery case to wear inside clothing in extreme cold.
- Optional panoramic adapter that permits use of 35mm film and yields 24x65mm images.
- Built with typical Mamiya quality for hard professional use and long service life.

Nomenclature Parts

Camera Body

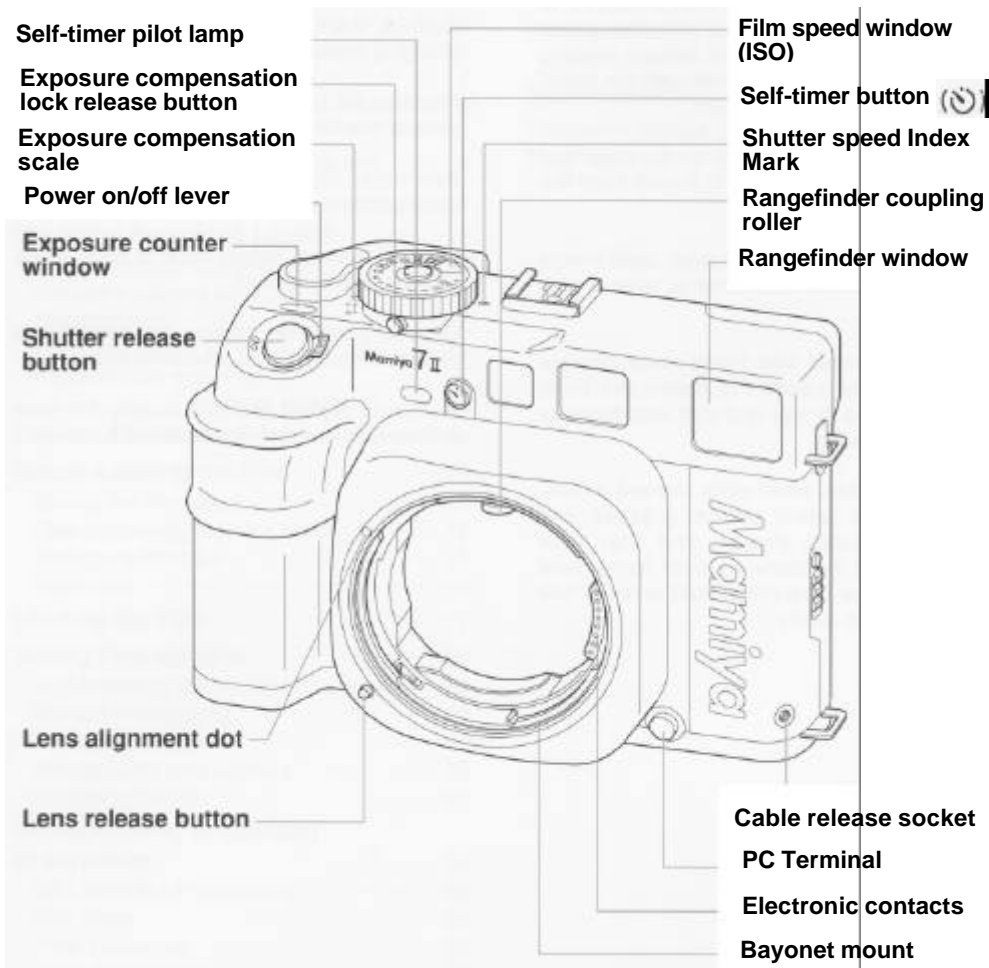

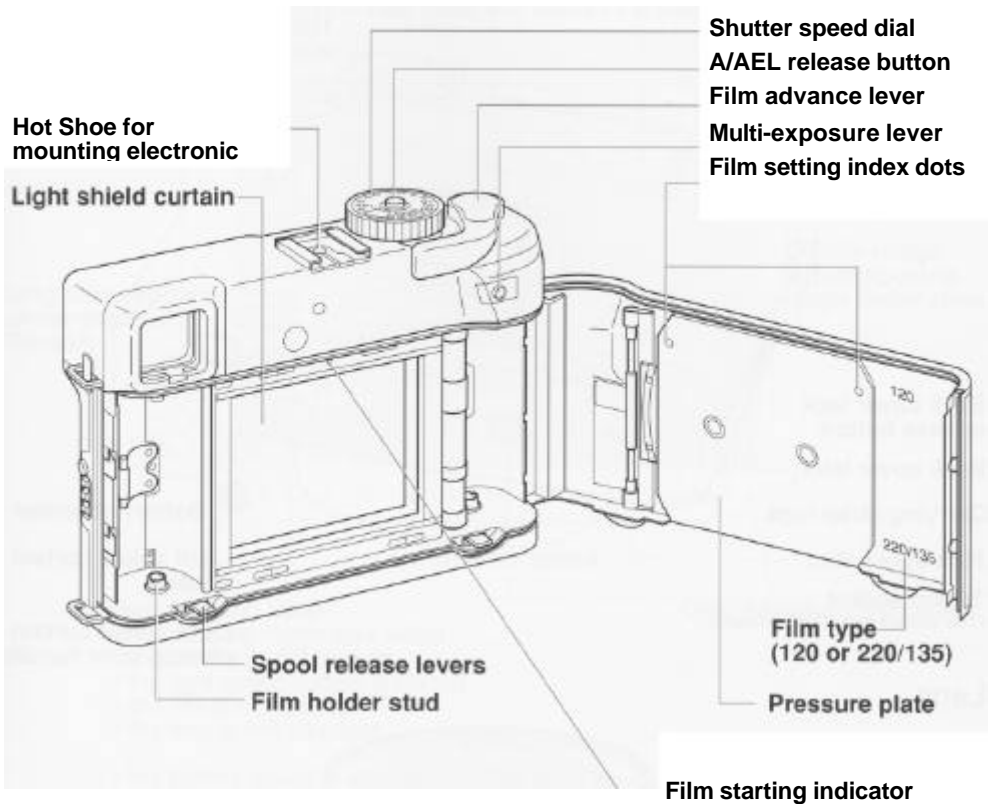

Nomenclature Parts

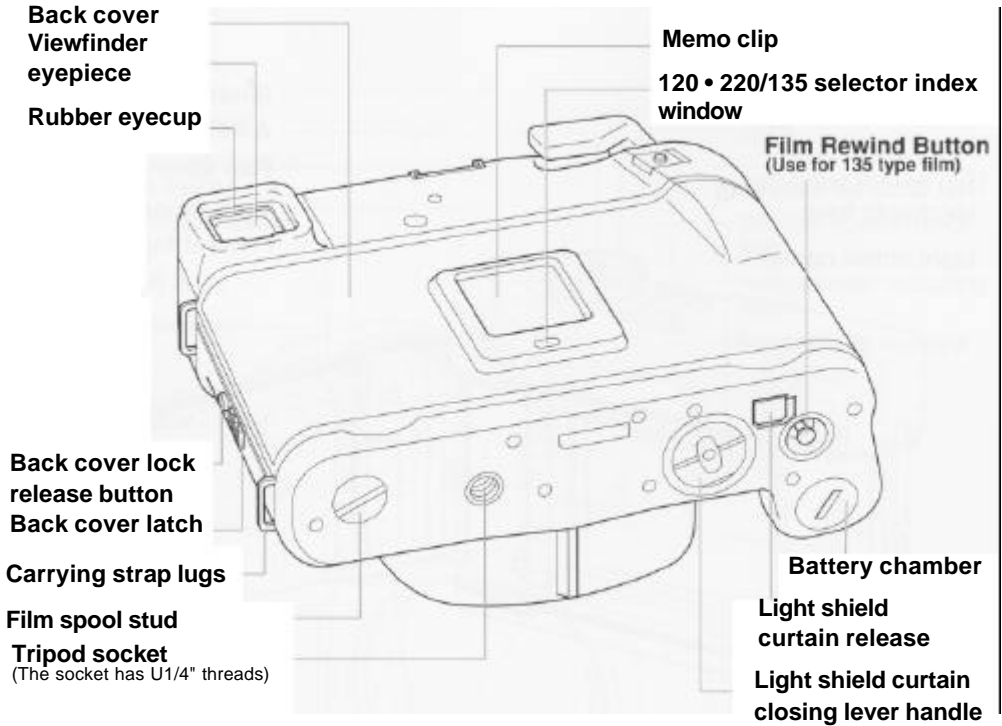

Lens

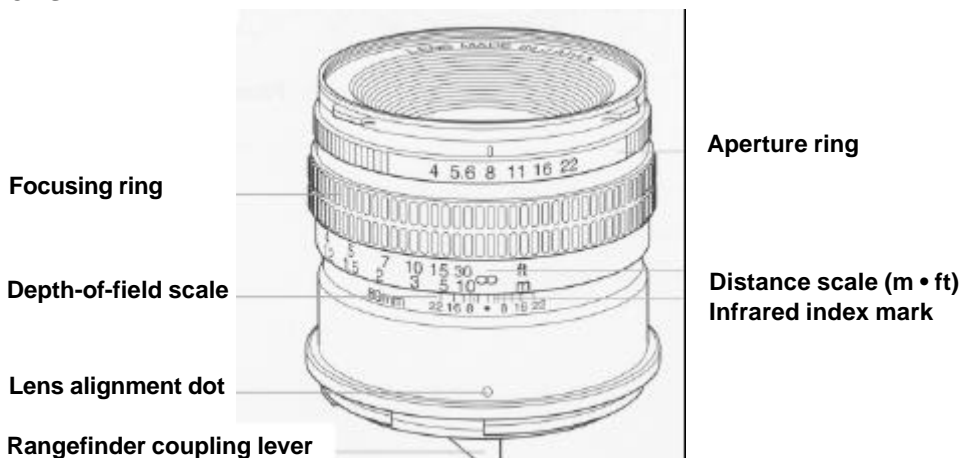

Viewfinder display

Bright field of view frame with 80mm F4 standard lens

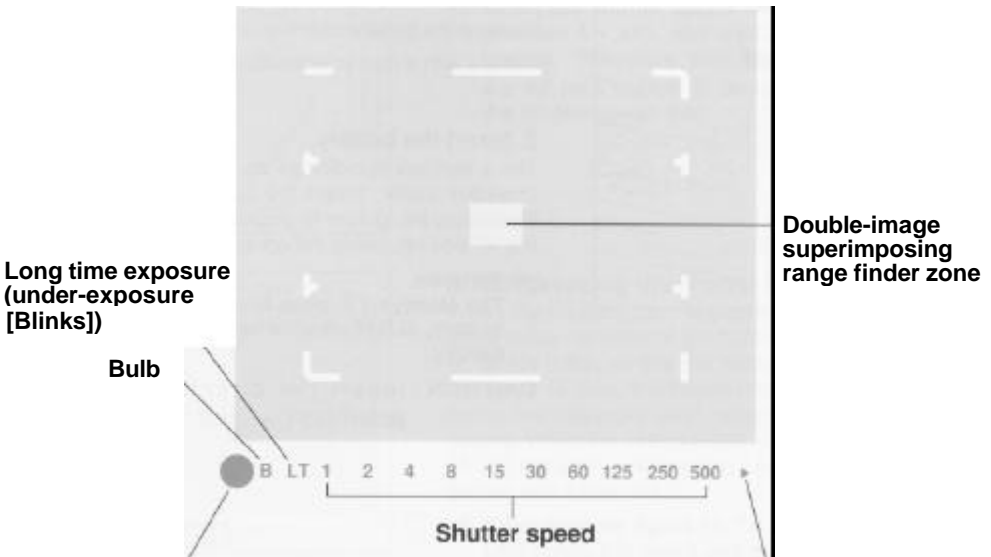

Long time exposure
(under-exposure
[Blinks])

Bulb

Double-image
superimposing
range finder zone

Red warning lamp

- The red lamp illuminates when
- the shutter is not cocked
 - the light shield curtain is closed
 - the film is not loaded
 - the lens is not attached

Over-exposure indicator

- the battery power is weakening : The lamp blinks.

Inserting Battery

The camera will not function without a battery.

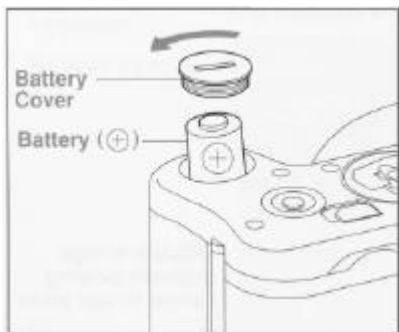

1. Remove the battery cover.

Remove the battery chamber cover on the bottom of the camera with a coin or screwdriver.

2. Insert the battery.

The + terminal is indicated on the inside of the battery chamber cover. Insert the battery as shown in the illustration, being sure to properly place the battery with the "+" side up, facing the cover.

* Batteries

The Mamiya 7II uses one of 4SR44 silver oxide battery, 4LR44 alkaline battery or 2CR1/3 lithium battery.

CAUTION : Insert the direction of battery polarities ("+" and "-") correctly.

Power ON/OFF

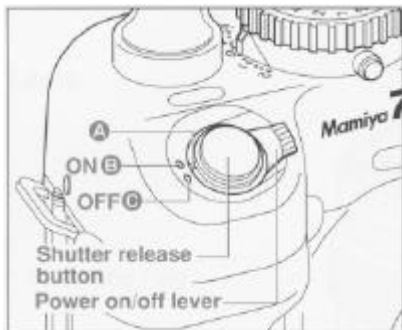

Power ON

To turn the Power ON, align dot "A" on the power switch lever with the "B" on the camera body.

Power OFF

To turn the Power OFF, align dot "A" on the power switch lever with the dot "C" on the camera body.

Shutter release button

The shutter release button is designed so that pressure can be applied in two stages. When it is lightly touched, correct metering data is displayed on the bottom of the view finder. When it is depressed all the way, the shutter is released and an exposure is made.

The LED's are located at the bottom of the finder in order not to interfere with the field of view of the wide angle lens.

Battery Check

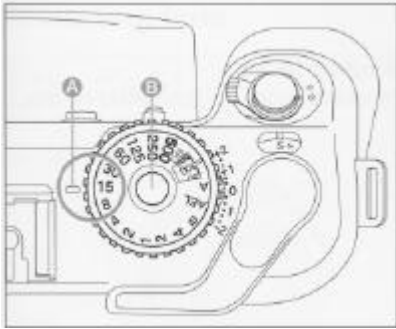

1. Set the shutter speed dial at 15.

Turn shutter speed dial and set the figure 15 at the dot "A"

***When the shutter speed was already set at the position A • AEL, the lock mechanism is functioning. Therefore, turn the dial while pressing the AE lock button "B" located at the center of the shutter speed dial.**

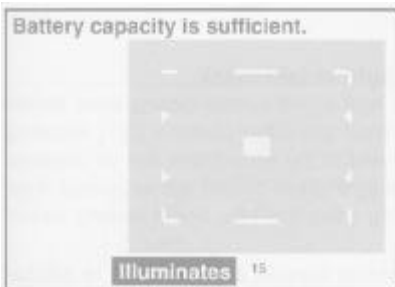

2. Half-pressing the shutter button.

When the shutter button is touched gently, the figure 15 lights in the red color at the bottom part in the viewfinder, which indicates that the battery power is normal. If the figure 15 blinks, it indicates drop of the battery power below the allowable level, when prepare for the new battery. When the battery power drops further, the figure 15 will not blink, and warning LED blinks. Replace the battery with a new one.

- **Other than set figure 15, blinks and warning LED lights, but check and confirm only set figure 15.**
- **Battery check can be done not only shutter speed at 15 but also other shutter speeds, viz: B - 1/1 to 1/500.**
- **Even when AE photographing, the battery check can be done with the shutter speed indicated in the viewfinder.**

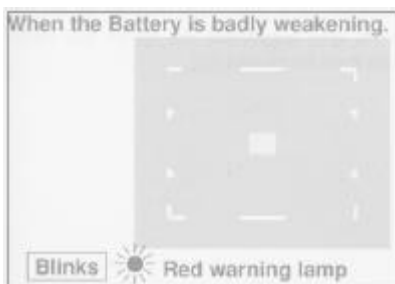
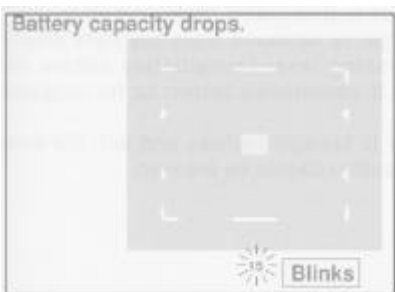

Mounting/Removing Lenses

Closing the light shield curtain

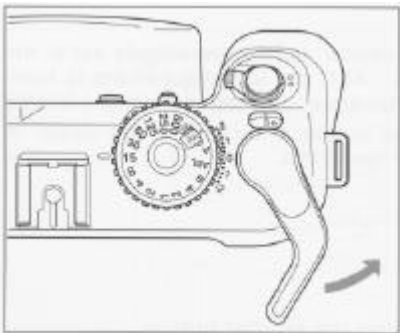

1. Cock the wind-up lever.

After cocking the shutter, close the light shield curtain.

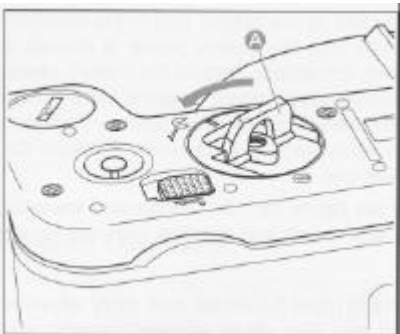

2. Close the light shield mask.

Set upright the light shield curtain closing lever handle "A" and turn it from the open position (" ") following arrow direction and fit the white index line on the lever to the closed position, the light shield curtain will be closed. After the motion, bring down the light shield closing curtain lever handle.

***The light shield curtain closing lever is ratchet type. Do not stop turning without going all the way. Be sure to turn until it clicks and stops. If your finger is removed from the light shield curtain closing lever immediately before its stopping, it sometimes return to its original position.**

If the lever is brought halfway and left, the lens removing button cannot be pressed.

Removing camera body cap

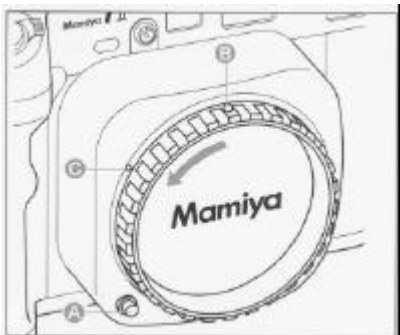

While pressing the lens release button "A" in, rotate the cap counterclockwise, and align the groove "B" on the cap's side with the lens alignment dot "C" on the body. The body cap can then be pulled out.

Mounting lens



1. Mounting lens.

Align Lens Alignment Dot "A" with the Camera Alignment Dot "B". Insert the lens into the camera body. Then turn the lens in the direction of the arrow (clockwise) until it clicks and locks into place.

- * **Remove the front and rear lens caps. The front lens cap can be removed by pressing in the tabs on the right and left with your fingers and pulling the cap towards you. The rear lens cap can be removed by rotating it counterclockwise.**

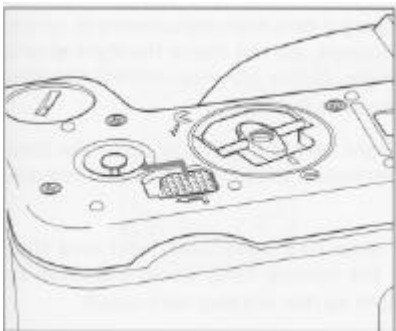

2. Opening the light shield curtain.

To open the light shield curtain, slide the light shield curtain release lever along to follow the arrow down and right. This will cause curtain to snap open. The light shield lever indicator- (a white line) is then aligned with "S".

- * **When the light shield curtain is closed, the shutter cannot be released. When taking a picture, open the light shield curtain.**

Removing lens

1. Cock the shutter and close the light shield curtain.

After cocking the shutter, close the light shield curtain just as same as mounting the lens.

2. Remove the lens.

While pressing the lens releasing button "A", turn the lens in the arrow direction until the lens alignment dot "B" lined up with the alignment dot "C" on the camera body, and pull out the lens.



- **Never touch the light shield curtain. If touched, light leakage or a malfunction may result.**
- **When removing a lens from the camera in which the film is loaded, do not move the light shield releasing lever. If this lever is moved, the film will be exposed to the light.**
- **When the light shield curtain is open the lens cannot be removed. Close the curtain to remove the lens.**
- **When the lens has been removed and film remains in the camera body avoid exposure to direct sunlight as film fogging may result.**
- **Put the front and rear lens cap on the lens**

Precaution for mounting/removing lenses

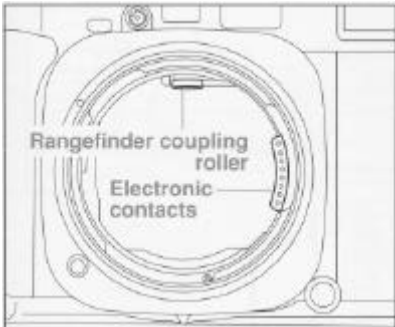

- 1) As the rangefinder coupling roller is precisely adjusted, be sure not to touch with your hand or move it with finger.
- 2) Gold plated electronic contacts are located inside the bayonet mount and at the rear of each lens. If oil, dirt, or other foreign matter collects on the contacts, poor electronic information transfer may result. When soiled, use a clean cloth to wipe them.

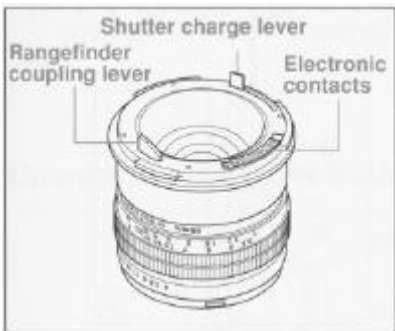

- 3) Be careful not to damage the rangefinder coupling lever and the shutter cocking lever at the rear of each lens.

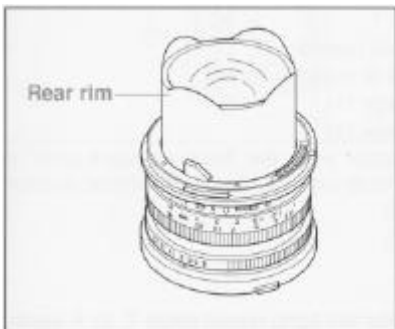

- 4) When mounting the 43mm, 50mm and 65mm wide angle lenses make sure that the rear lens rims do not touch the rangefinder coupling roller.

Position the front face of the lens which has been removed as shown in the left illustration.

Camera Functional Test

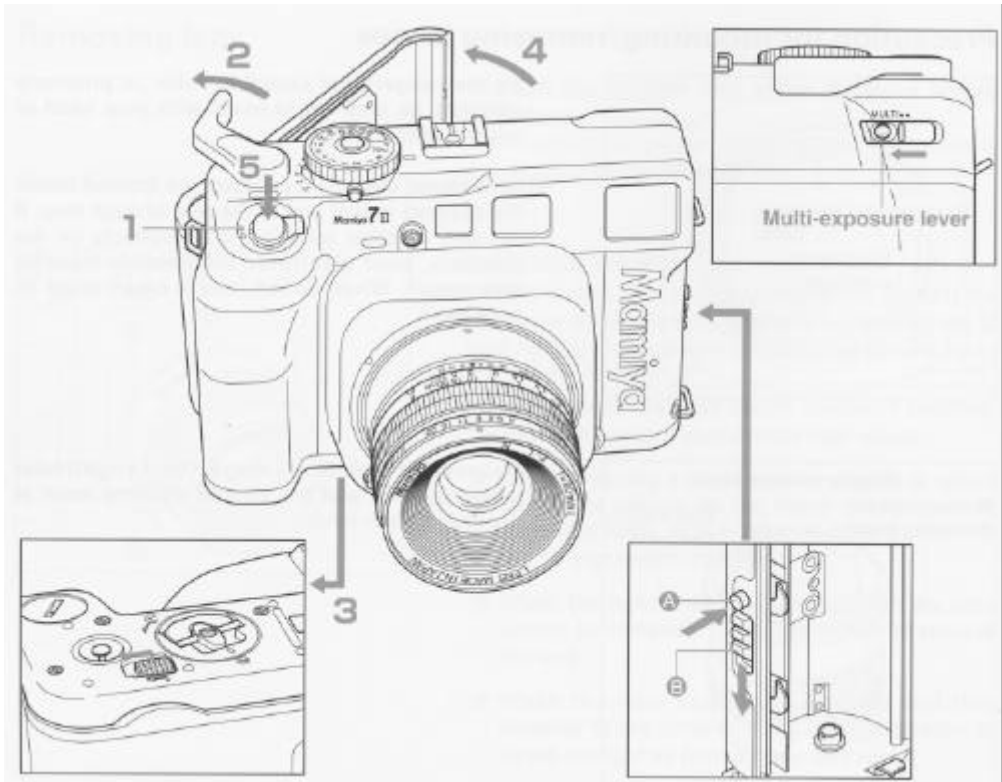

Before using the camera, it is advisable to understand how it works.

- ① Power on/off lever Set to ON. (See page 8)
- ② Film advance lever Wind the lever to cock the shutter.
- ③ Light shield curtain Open.(See page 11)
- ④ Back cover Open.(See page 15)

- ⑤ Release the shutter (See page 26)
- (The shutter can be released without opening the back cover while the "Multi-exposure lever" is being shifted to "MULTI" position. Be sure to return the "Multi-exposure lever" to original position after completion of the test.) (See page 32)

Note:
If the shutter is not released, red warning lamp in the viewfinder will light; repeat steps ② to ④ again.

Tip:
To observe the function of the shutter release and the interaction between the light shield curtain shutter and lenses, you need not load film in the camera. Just leave the back cover open.

Before Loading the Film

Setting the film speed

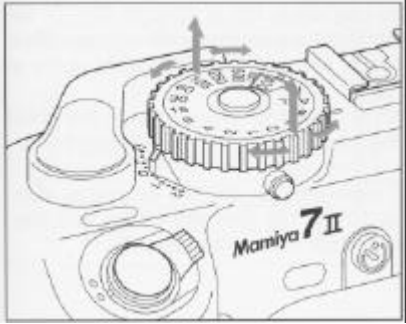

Set the film speed of the film being used by lifting up the outer rim of the shutter speed dial and rotate it until the correct ISO value appears in the window.

***Be sure to set the exact film speed, as otherwise incorrect exposure will result.**

ISO

25 • • 50 • • 100 • • 200 • • 400 • • 800 • • 1600

(32)(40) (64)(80) (125)(160) (250)(320) (500)(640) (1000)(1250)

Opening/closing the back cover

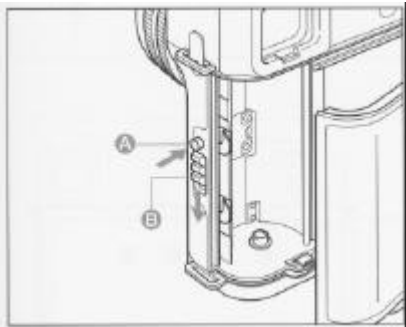

While depressing the back cover lock button "A", simultaneously push down the lock lever "B" in the direction of the arrow and the back will open. When closing the back cover, securely press both corners until it clicks.

Setting the film type

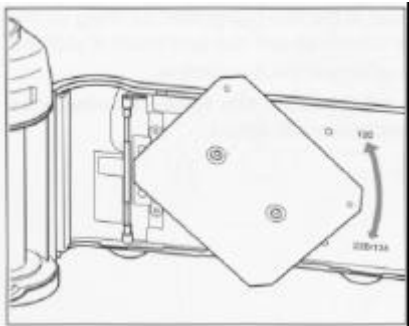

This camera can use either 120 or 220/135 film. To set for the type of film used, simply rotate the pressure plate in either direction of the arrow until the white dot is at "120" or "220/135".

When set, "120" or "220/135" will appear in the small window under the memo clip on the rear of the camera.

The number of exposures on the film counter is automatically set at 10 for 120 film and 20 for 220 film, according to the position of the pressure plate.

Memo clip



This memo clip on the back cover is used to hold the film box tab to serve as a convenient reminder of the type of film in the camera or for recording other data.

Loading the Film

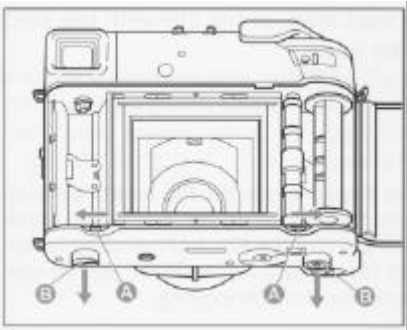

1. Operate the spool bearing release lever.

Push the spool release lever "A" on right side to the right, and install the take-up spool in the take-up spool chamber "B", top first, then push the lower spool stud up.

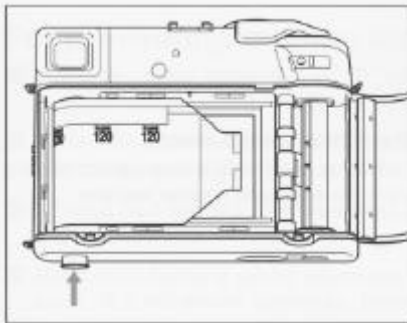

2. Place the film in the film chamber.

Like installing the take-up spool, push the spool release lever on left side to the left, place a roll of film in the film chamber, making sure it seats properly. Make sure the backing paper is in the position illustrated above, black side facing the lens, colored side towards the back.

When the new roll has been inserted, be sure to reset the lower spool stud by pressing it in. (Also, be sure to reset the take-up spool stud in a similar manner.)

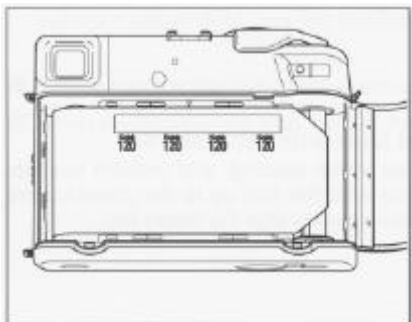

3. Insert the film into the groove of the spool in the wind-up chamber.

Pull out the backing paper, and insert the tip into the slot on the take-up spool as pictured.

Loading the Film

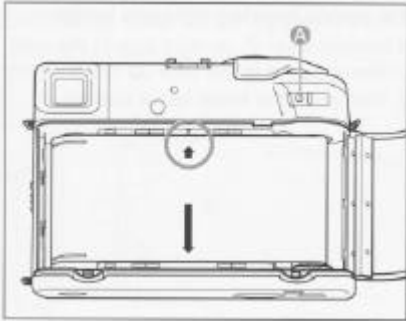

4. Align the start mark of the film with the start mark on the body.

Wind the film advance lever until the small arrow (the starting indicator on the backing paper) aligns with the film starting indicator (▼) on the camera body. Then close the back cover.

- **Thread the paper leader on the empty take up spool so the film will be wound evenly and parallel. This will prevent the film from winding loosely or over the edge of the spool, which can cause light leaks and film fogging.**
- **If the multi-exposure lever "A" is shifted to "MULTI" position, film will not advance.**

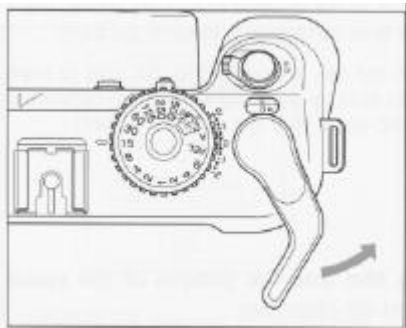

5. Wind up the film advance lever.

Wind the film advance lever until it stops automatically and "1" appears in the exposure counter window.

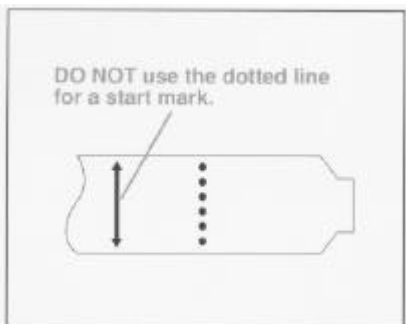

Setting Start Mark with 220 Roll Film

To assure even frame spacing, and prevent overlapping, be sure to wind the film up to the printed arrow start mark, which appears after the dotted line.

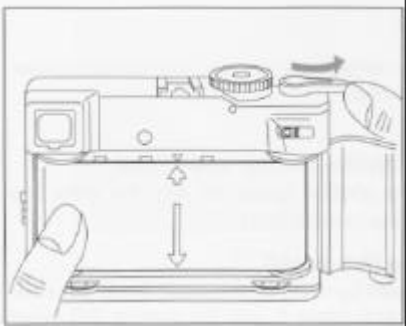

Prevention of Light Leaks Due To Loose Film Winding

*** Use your left thumb to press lightly on the paper leader while advancing winding lever slowly to assure smooth and tight film take-up on the empty spool. Advance the film and align the printed arrow start mark with the small triangle start mark on the camera. Then close the camera back.**

For preventing the film loose winding

- When any other numeral than "S" appears in the exposure counter window, it is an indicted that the film is loaded. So do not open back cover.
- If the film is not properly aligned with the "▼" indicator, the film may be improperly loaded and cause spacing problems.
- When a 6EX roll film (5 exposures) is used, the procedure of loading the film is the same as with 120 roll film.
- Make sure backing paper advances evenly between the spool flanges and does not begin to slant. If it advances unevenly, remove the backing paper from the take-up spool and start over again.
- Do not pull excessively on the backing paper, and do not load/unload the film in direct sunlight: bright light may fog the film.
- Before loading the film into the camera, be careful of the film looseness.
- When photographing with the 135 Panoramic Adapter, see its instructions.

Taking Photographs

AE (Automatic Exposure) Photography

The aperture priority metering device is incorporated into the rangefinder system. The correct shutter speed for the preselected aperture will automatically be determined.

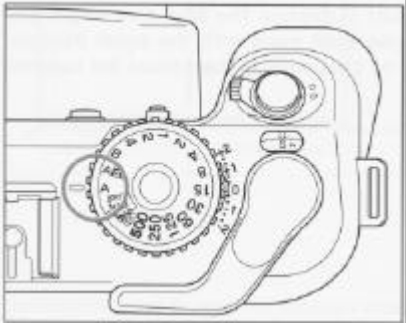

1. Align "A" on the shutter speed dial.

Align "A" on the shutter speed dial with the white line index mark on the camera body.

2. Setting the film speed.

Set the film speed by lifting up the outer rim of the shutter speed dial and rotate it until the correct ISO value appears in the window.

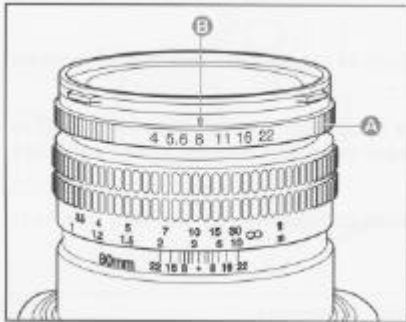

3. Set the aperture.

To set the diaphragm to a desired aperture, rotate the aperture ring "A" until the appropriate figure is aligned with the central red index line "B".

* **Click stops are provided at each engraved aperture number but the diaphragm can be set also for intermediate stops.**

* **At A or AEL, the dial is locked. The lock can be released by pressing the AE lock release button in the center of dial.**

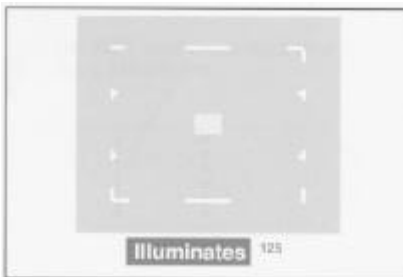

4. Half-pressing the shutter button.

When the shutter release button is slightly touched, an LED indicating proper exposure will automatically light in the viewfinder.

When it is depressed all the way, the shutter is released and an exposure is made.

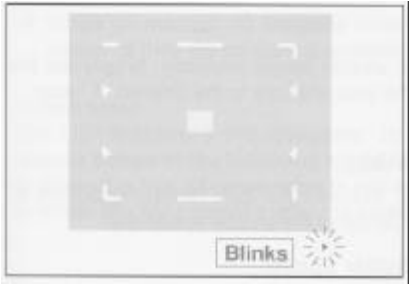

When “▼” LED blinks, it indicates overexposure. Rotate the aperture ring to stop down to a smaller f/stop until an LED indicates proper exposure.

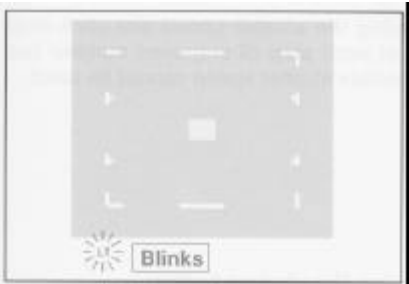

Blinking "LT" indicates under-exposure: rotate the aperture ring until the LED stops blinking to increase exposure.

Illuminating "LT" indicates that the shutter is set for a relatively long exposure from between 1 to 4 seconds.

When taking pictures at such slow speeds you must be able to hold the camera very steady, or increase aperture to obtain higher shutter speeds, or best of all, use a sturdy tripod.

Under AE (automatic exposure) or AEL (AE lock), the LED display in the viewfinder will continue to operate as long as the shutter release button is touched slightly. When you take your finger off the button, the LEDs will go out.

Manual Photography

You may override the AE mode and select the aperture and shutter speed manually. Simply set the shutter speed against the white line index mark and also set the lens aperture to the desired " f " stop.

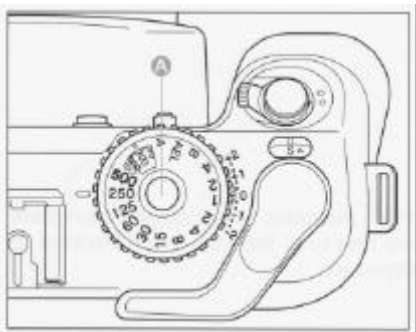

1. Release A-AEL.

For releasing, depress AE lock releasing button "A" located in the center of the shutter speed dial.

2. Set the shutter speed.

Rotate the shutter speed dial and align with index line of the camera body.

- **While rotating the shutter speed dial click-stop functions at each step of engraved number but the intermediate shutter speed cannot be used.**

When using built-in exposure meter

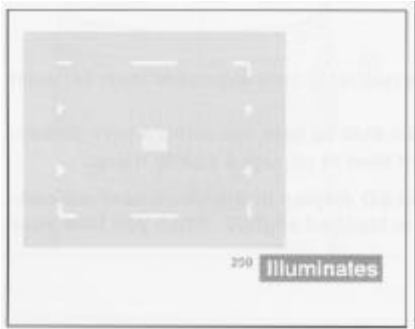

1. Half-pressing the shutter button.

When the shutter release button is touched gently, the selected shutter speed LED only will be continuously illuminated or another LED may also flash.

2. In the case where one shutter speed is lighting.

When the pre-selected shutter speed LED only illuminates, it indicates the shutter speed for correct exposure.



3. In the case where two shutter speeds (one is blinking) are displayed.

When the preselected shutter LED illuminates and one other LED blinks the blinking LED indicates the shutter speed for correct exposure.

Turn the shutter speed dial and/or aperture ring to align the two LEDs until merged. The single LED indicates

- **When on manual, 10 seconds after activation, the LED indicators will go out, to save battery power. If they do so during metering, press the Shutter Release Button half way again.**

Please note: The LED indicators will disappear 10 seconds after you remove your finger from the shutter release button in the following situations:

- 1) **When the film advance lever is not advanced.**
- 2) **When the light shield curtain is closed.**

Focusing the Lens

When the lens has been focused, the double image superimposing rangefinder produces two superimposed images with in the square of the viewfinder.



Focusing method within the double image coincidence zone

Position the subject within the central square of the viewfinder. As on the top left the subject will appear as double images.

Rotate the focusing ring until the two images converge and are superimposed as on the figure on the left. The lens is now focused.

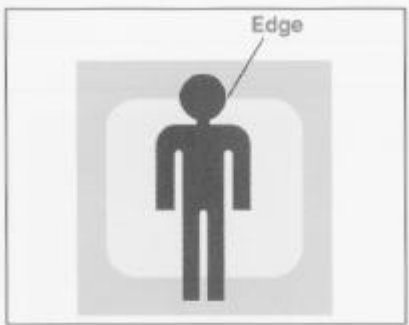
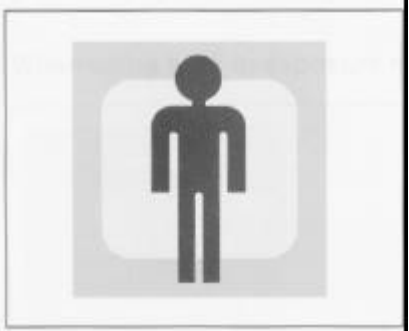

Focusing method at the edge of double image coincidence zone

Look at the object through the rangefinder and rotate the focus ring so as to make two images into one without any imaginal slippage at the edge of the central double image coincidence zone. As this method improves the focusing preciseness, this is especially effective for N150 mm f/4.5 L lens.

Photographic area covered

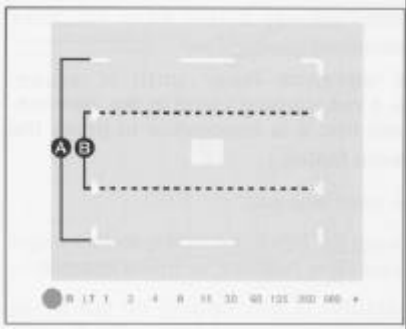

Within the viewfinder the subject area covered is indicated by the visible bright frame. Parallax is automatically compensated for according to the subject-to-lens distance. The composition will be within in the lines of the bright frame "A" for 6 x 7 format and "B" for 135 panoramic format. 83% of the field of view is visible at infinity, and 100% is visible at the minimum focusing distance. The appropriate bright frame area is automatically indexed upon lens interchange.

However, for 43 mm, 50 mm lens, an exclusive viewfinder must be used. Also, for composition check purpose, an exclusive viewfinder for 150 mm lens is sold separately.

1. Pressing the shutter button.

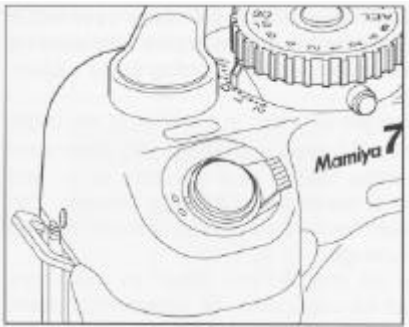

Press the shutter release button when you have focused and determined composition.

- **Wind the advance lever until it stops. (Otherwise, a red warning Lamp in the viewfinder will signal that it is impossible to press the shutter release button.)**
- **Remove the front lens cap.**
- **Do not advance the film too quickly, as this might adversely affect film flatness, or frame spacing.**
- **While the shutter is functioning do not try to cock the film advance lever, because the film will be moved during exposure.**

2. After completing the last exposure.

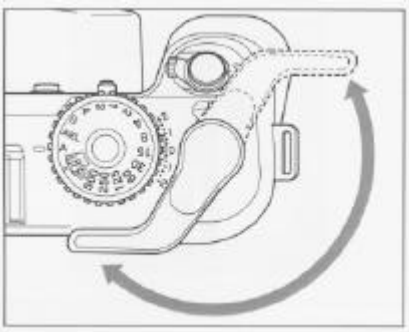

After completing the last exposure, wind the advance lever several times until the film with its backing paper is completely wound onto the take-up spool. The advance lever will become easier to actuate when the film has been completely wound on the spool.

Unloading the film

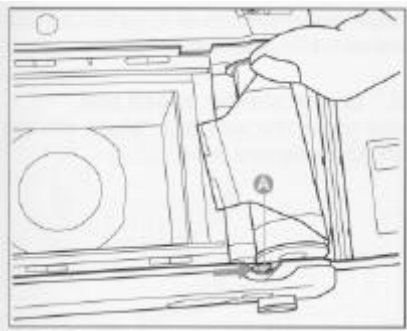

1. The back cover open.

While pressing the back cover lock button, push the back cover open/close button, then the back cover will open.

2. Unloading the film.

Push the spool stud releases lever "A" to the right in order to disengage the spool from the stud.

- **Simply push the upper rim of the spool with your index finger as shown to lift up the other end of the spool.**
- **To prepare for another roll, remove the empty spool from the film chamber, and place it in the take-up chamber.**
- **To remove the film before exposing the entire roll, cap the lens and press the shutter release button and wind the film onto the take-up spool frame by frame.**
- **For unloading method of Panoramic photographing with 135 mm film, refer to Instruction Manual for 135 Panorama Adapter Kit AD701 (sold separately).**

3. Seal the unloaded film.

Be careful not to let the roll of exposed film unwind. Be sure to seal it immediately.

Handling of Exposed Film

- **DO NOT** remove exposed film from the camera under direct sunlight. Find a shaded area or turn your back to the sun and shade the camera before you open it.
- **Immediately** place exposed film in your camera case or a bag, away from sunlight.

Photographing to conform to purposes

AE Lock (AEL) Photography

The AEL position is very useful when making selective exposure measurements of important subject areas which are not in the center of the finder image when faced with difficult lighting conditions.

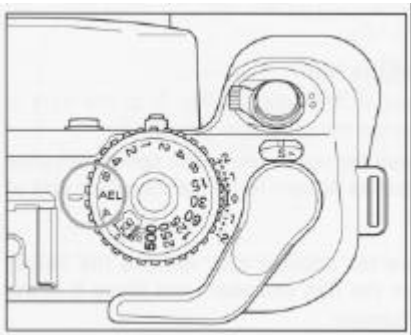

1. Align "AEL" on the shutter speed dial.

Rotate the shutter speed dial until "AEL" aligns with the white index mark on the camera body.

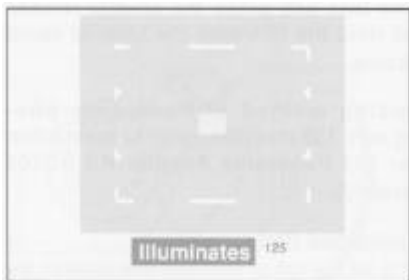

2. Half-pressing the shutter button.

Position the important part of your subject in the central square of the viewfinder -this will establish the correct exposure. Then touch the shutter release button slightly and an LED will light indicating the correct exposure.

3. When changing composition.

In above state, the exposure reading will be memorized. After adjusting for composition as desired, release the shutter.

If you cannot get close enough to your subject for another meter reading make substitute measurements by pointing the camera to light and dark areas and calculate a mean exposure value or try taking a reading off your palm.

Self-Timer

The shutter is released about 10 seconds after pressing the self-timer button. The LED on the front of the camera illuminates for about 8 seconds, then blinks for about 2 seconds and then the shutter is released.

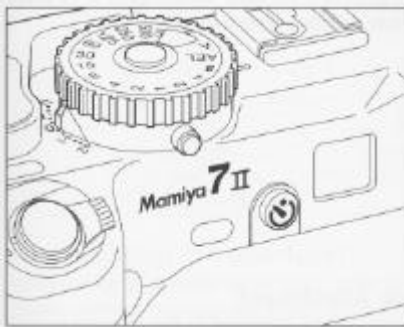

1. Fix the camera to a tripod.

2. Press the self-timer button.

Cock the wind-up lever and press the self-timer button

 The self-timer mode cancels itself automatically.

- When the shutter is set to "B" (bulb), the self-timer does not operate.
- To override the self-timer, after having pressed the release, press the self-timer button  again. Then the self-timer lamp will go out and then the self-timer mode will be canceled.
- When using the self-timer the camera must rest on a steady support.

Precaution when Self-timer Photographing

- When battery check, the self-timer sometimes does not function because of the fact that the amount of the battery to be consumed for shutter release function is different from that of the self-timer functioning. In such a case, replace the battery with a new one.

Time Exposures

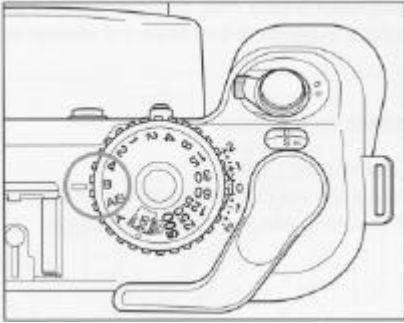

When taking an exposure longer than 4 seconds, set shutter to "B" (bulb). At "B" the shutter will remain open as long as the release is pressed down.

- **In order to prevent camera movement it is best to use a cable release and tripod.**

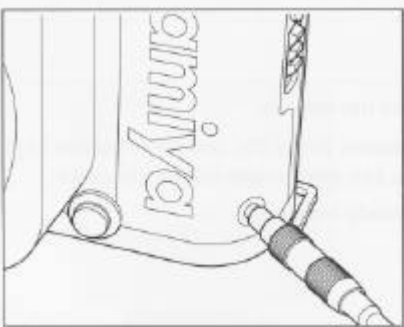

Cable Release Attachment

The cable release can be screwed in the release socket on the lower left side of the body as pictured.

Precautions for Bulb Photographing

- **When bulb photographing, the battery is consumed. A new alkaline manganese battery is durable for about 3 hours, silver oxide battery and lithium battery for about 7 hours. When the battery is fully consumed, the shutter will be closed automatically.**

[Using a tripod]

When using the camera with a large tripod head, the head may interfere with the spool stud, preventing film from being loaded. To prevent this, use the optional tripod adapter N.

- **The threaded tripod screw hole is 5.5mm deep and the use of a longer tripod screw might result in damaging the camera. So be careful not to apply unnecessary pressure when mounting the camera.**

Flash Photography

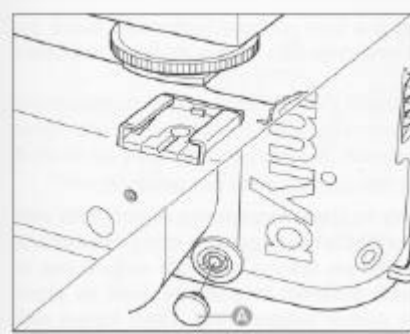

The Mamiya 7II features an X synchro flash terminal and its lens shutter system permits flash synchronization at all shutter speeds.

Shoe-mounted flash units can be attached directly to the hot-shoe, while flash brackets can be attached to the tripod socket for larger flash guns.

Remove safety cover "A" to attach sync cord to PC terminal on front left bottom of camera.

[Determining the aperture]

When using automatic flash units, refer to the instructions on the flash unit for correct aperture settings. When using a manual electronic flash the guide number divided by subject distance gives the correct aperture.

$$\frac{\text{Guide number (32)}}{\text{Subject distance (4m)}} = \text{Correct aperture setting (8)}$$

- 'X' contact of this camera is an exclusive contact for strobe.
- Charged electronic flash units sometimes fire when they are attached to the camera. This does not indicate a defective circuit.
- When using electronic flash, be sure to read its manual carefully.
- Be careful, if electronic flash is used at the "A" (Auto exposure) mode, overexposure may occur.

CAUTION

- When an electronic flash is connected to the hot-shoe, current moves through the X contact. So be sure to put the safety cover supplied with the camera on the X contact so that you will not receive an electric shock.
- When using strobe, never bring the camera close to human eyes (including all living things) especially little children, because if it is flashed near the eyes, it can cause serious visual trouble.

Multiple exposure mechanism

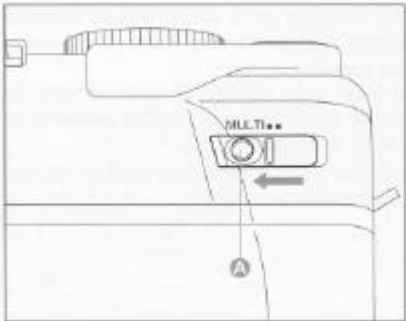

While pressing the lock release button “A”, move the lever in the arrow direction to the multiple exposure position.

It does not matter if the changeover to multiple exposure is made before or after the first exposure. Once changed, the shutter is released and wind-up lever is cocked, but the film counter does not advance.

- **When taking multiple exposures of subjects with the same brightness, exposure compensation is necessary. When taking multiple exposures of subjects with different brightness, take an exposure of the darker subject first. Then follow with an exposure of the lighter subject.**
- **After finishing multiple exposure photographing, be sure to return the lever to normal position.**

Infrared Photography

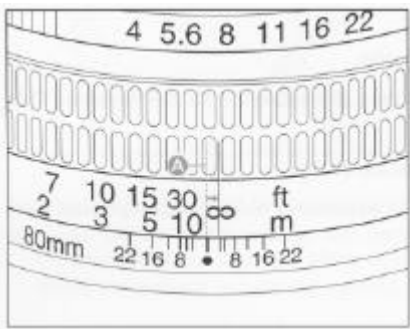

When using infrared film, it is necessary to make a focusing adjustment in order to achieve accurate focus. This is because the focus position of the image deviates from normal since the infrared ray wavelength is longer. After focusing in the usual manner, check the distance on the distance scale that is aligned with the center reference mark “A” of the lens. Make the focusing adjustment by turning the focusing ring in the direction of the arrow in the accompanying photograph so that the distance just observed is aligned with the infrared mark.

***When using infrared film, be sure to read the instructions with the film.**

Exposure Compensation

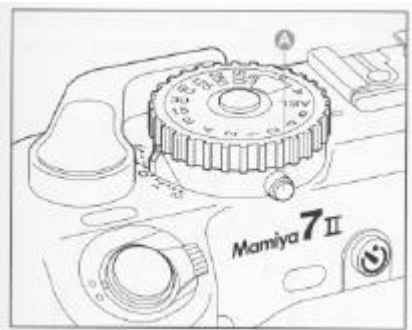

The exposure compensator functions in a number of important ways. It can be used to correct exposure values (EVs) or the differences in brightness between a primary subject and its background -especially when over or under-exposures occur. It can also be used when filters are employed or when engaged in available light photography -or under high contrast conditions (i.e. low or high key).

To set, press the compensator lock release button "A", and select the desired EV: graduations are 1/3 EV.

[When a filter is used]

Whether using the AE or manual mode simply compensate for the filter exposure factor as indicated in the table below.

Filter exposure factor	×1	×1.2	×1.5	×1.7	×2	×2.5	×3	×4
Exposure compensation value (EV)	0	+ $\frac{1}{3}$	+ $\frac{2}{3}$	+ $\frac{2}{3}$	+1	+1 $\frac{1}{3}$	+1 $\frac{2}{3}$	+2

*After using exposure compensation, be sure to reset to "0".

Precautions for Using Polarized Light Filter (PL)

As this camera is the rangefinder type, it is impossible to check polarized light effect in the viewfinder. However, it becomes possible to use the filter by means of following procedures.

Be sure to make prior test and check the effect beforehand.

1. Check the polarized light effect position.

Before fitting the PL filter to the lens, apply your eye to the filter and remember the position (a letter or mark mentioned on the filter) or put a mask is on the filter front frame.

2. Fit to the lens.

Fit the filter so that the mark and the like put on the filter front frame will become to the same position.

- As the transmitting amount of light differs according to rotating angle of the PL filter, exposure compensation is necessary.
- Make test photographing and calculate the compensation value.
- You may use either a circular type or linear type polarized light filter.

Diopter Correction Lenses

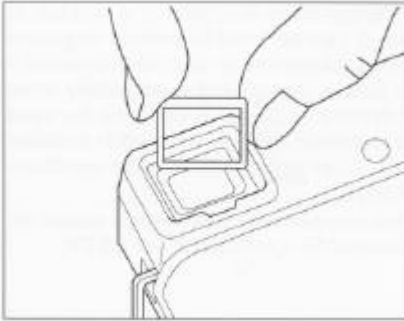

Six types of diopter correcting lenses are available for near/farsighted people. Mount as indicated above.

Powers available are: +3, +2, +1, -1, -2, and -3.

+: Far-Sighted

-: Near-Sighted

Depth-of-Field

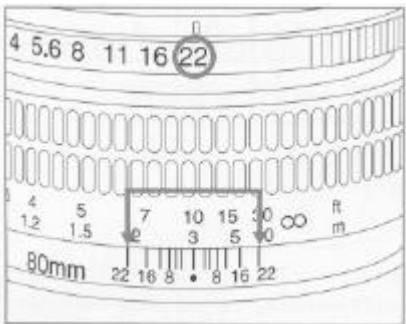

The depth-of-field varies according to the aperture. The smaller the aperture ($f/8$, $f/11$, $f/16$...) the greater the depth-of-field; the larger the aperture ($f/8$, $f/5.6$...) the smaller the depth-of-field. To take pictures which are sharp from foreground to infinity or when taking snapshots, the focusing range is extended or depth increased by using a smaller aperture. When the subject is to stand out, with the background out of focus, a larger aperture is appropriate.

The depth-of-field scale on the lens indicates depth-of-field in terms of the distance between subjects on both sides of the scale. For example, when a 80mm lens is stopped down to $f/22$, respectively, all objects located within the ranges shown in the illustrations above will be sharp.

*** Refer to the instructions attached to individual lenses for specific depth-of-field tables.**

How to Hold the Camera



Because most out of focus pictures are the result of camera movement, make sure not to move when pressing the shutter button. Hold the camera with your elbows close to your body: pressing part of the camera on your forehead will help stabilize it. Then gently release the shutter.

When making exposures longer than 1/30 sec., it is advisable to use a tripod with a cable release.

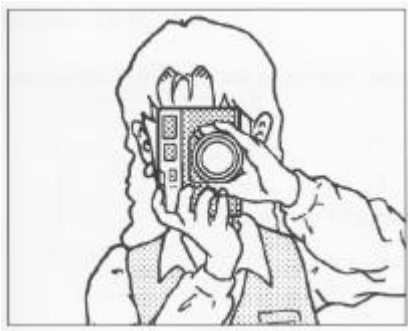

Neck strap

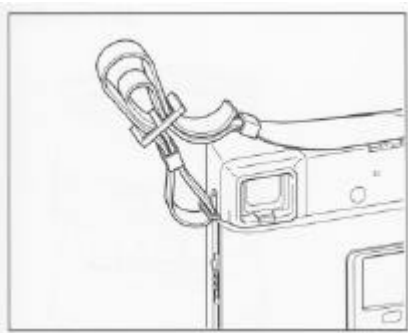

Pass the neck strap through the carrying strap lugs, and fasten it as shown.

TIP:

Be sure to focus the lenses by spanning the lower part of the focusing collar with your fingers, in order not to block the rangefinder window.

Trouble shooting

Uniquely designed to prevent errors, the Mamiya 7II incorporates numerous safety features. If the shutter will not function, it is very likely due to user error rather than camera malfunction. Should there be problems, be sure to review the following points.

- **When the shutter will not function.**

- ① Is the battery good?
- ② Is the power on/off lever set to the white dot "ON" position?
- ③ Has the film been completely advanced to the next frame?
Have all the exposures already been made (10 with 120, 20 with 220)?
- ④ Has the film advance lever been moved until it stops?

⑤ Is the light shield curtain closed?

(In the case of examples ③ ~ ⑤, the red warning Lamp will flash a warning on the lower left hand corner of the viewfinder.)

- **When the lens cannot be removed:**

Is the light shield curtain open?

The light shield curtain must be closed, and the film advance lever must be advanced and shutter cocked to remove the lens.

- **When the film cannot be advanced:**

Isn't the multi-exposure lever shifted to "MULTI" position?

Film will not advance if the multi-exposure lever is shifted to "MULTI" position.

Lenses

N43mm f/4.5L

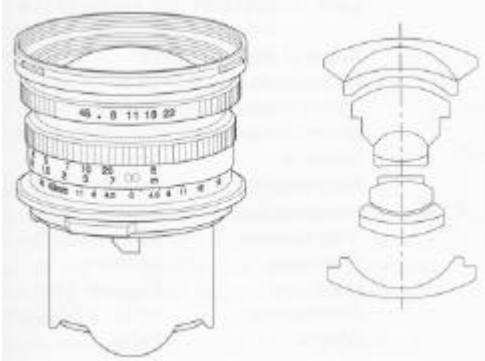

Lens construction	: 10 elements in 6 groups
Angle of view	: 92°
Minimum aperture	: 22
35mm equivalent	: 21mm
Minimum focusing distance	: 1m
Magnification at minimum distance	: 0.049
Area covered	: 1145 x 1421 mm
Filter size	: 67mm
Hood	: Bayonet type
Dimensions	: 42 (L) x 72 (D)mm
Weight	: 390g

N50mm f/4.5L

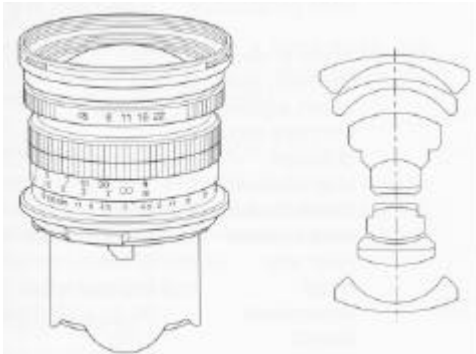

Lens construction	: 10 elements in 6 groups
Angle of view	: 84°
Minimum aperture	: 22
35mm equivalent	: 25mm
Minimum focusing distance	: 1m
Magnification at minimum distance	: 0.063
Area covered	: 895 x 1111 mm
Filter size	: 67mm
Hood	: Bayonet type
Dimensions	: 55 (L) x 70 (D)mm
Weight	: 456g

N65mm f/4L

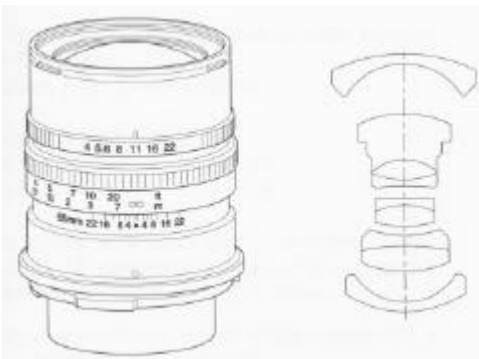

Lens construction	: 9 elements in 5 groups
Angle of view	: 69°
Minimum aperture	: 22
35mm equivalent	: 32mm
Minimum focusing distance	: 1m
Magnification at minimum distance	: 0.078
Area covered	: 719 x 892mm
Filter size	: 58mm
Hood	: Bayonet type
Dimensions	: 65 (L) x 67 (D)mm
Weight	: 380g

N80mm f/4L

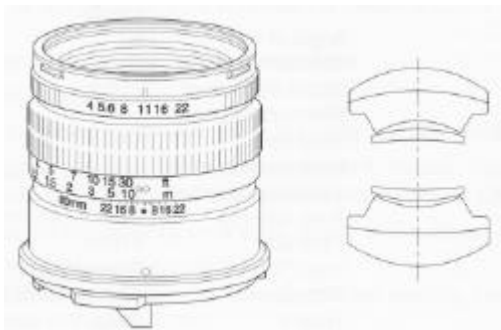

Lens construction	: 6 elements in 4 groups
Angle of view	: 58°
Minimum aperture	: 22
35mm equivalent	: 39mm
Minimum focusing distance	: 1m
Magnification at minimum distance	: 0.097
Area covered	: 580 x 719mm
Filter size	: 58mm
Hood	: Bayonet type
Dimensions	: 56 (L) x 67 (D)mm
Weight	: 290g

N150mm f/4.5L



Lens construction	: 6 elements in 5 groups
Angle of view	: 34°
Minimum aperture	: 32
35mm equivalent	: 71mm
Minimum focusing distance	: 1.8m
Magnification at minimum distance	: 0.096
Area covered	: 581 x 721mm
Filter size	: 67mm
Hood	: Bayonet type
Dimensions	: 96 (L) x 70 (D)mm
Weight	: 520g

Lens hood

For 43mm f/4.5: Bayonet type
For 50mm f/4: Bayonet type
For 65mm f/4: Bayonet type
For 80mm f/4: Bayonet type
For 150mm f/4.5: Bayonet type
All are supplied with the lenses.

Dioptr correcting Lenses

Focusing accuracy diminishes when the eye dioptr is incorrect. So, it is advisable that near and far sighted people use dioptr correcting lenses. Fit the proper dioptr correcting lens to the eyepiece.

6 types are available: +3, +2, +1, -1, -2, and -3.

Tripod adapter N

This is used to mount the camera to tripod head. Even when the tripod has a large head, the adapter allows film to be loaded, while the camera is attached to the tripod.

Panoramic Adapter Kit AD701

When using the Panoramic Adapter, a wide panoramic photograph can be taken by using 35mm film. The 135 panoramic Adapter Kit is composed of the following:

- ① 135 Panoramic Mask
- ② Take-up Spool
- ③ Cassette Holder
- ④ Rewind Crank Unit
(Unit Weight: 110g)

- 135 Panoramic Picture Area and the Number of Exposures.
Picture area: 24mm x 65mm

Number of exposures:

135 Film 36EXP 16
135 Film 24EXP 10

The picture area (24 x 65mm) provided by the Mamiya 7II panoramic format is 3.3 x larger than the 35mm panoramic format (13 x 36mm)

Note: A panoramic paper slide mount 24 x 65mm, is also available.

Lens case Type A

The lens case is made of special material which is very soft but tough and fits 43mm, 50mm, 65mm, 80mm and 150mm lenses.

Dimension: bottom diameter is 90mm and it is 160mm in length.

External Battery Case PE702

Cold temperatures can affect battery power.

Permits camera battery to be worn conveniently inside clothing and connected to battery chamber by wire.

Viewfinder FV701 for 43mm f/4.5 lens

See lens instructions booklet.

Viewfinder FV703 for 50mm f/4.5 lens

See lens instructions booklet.

Viewfinder FV702 for 150mm f/4.5 lens

System chart

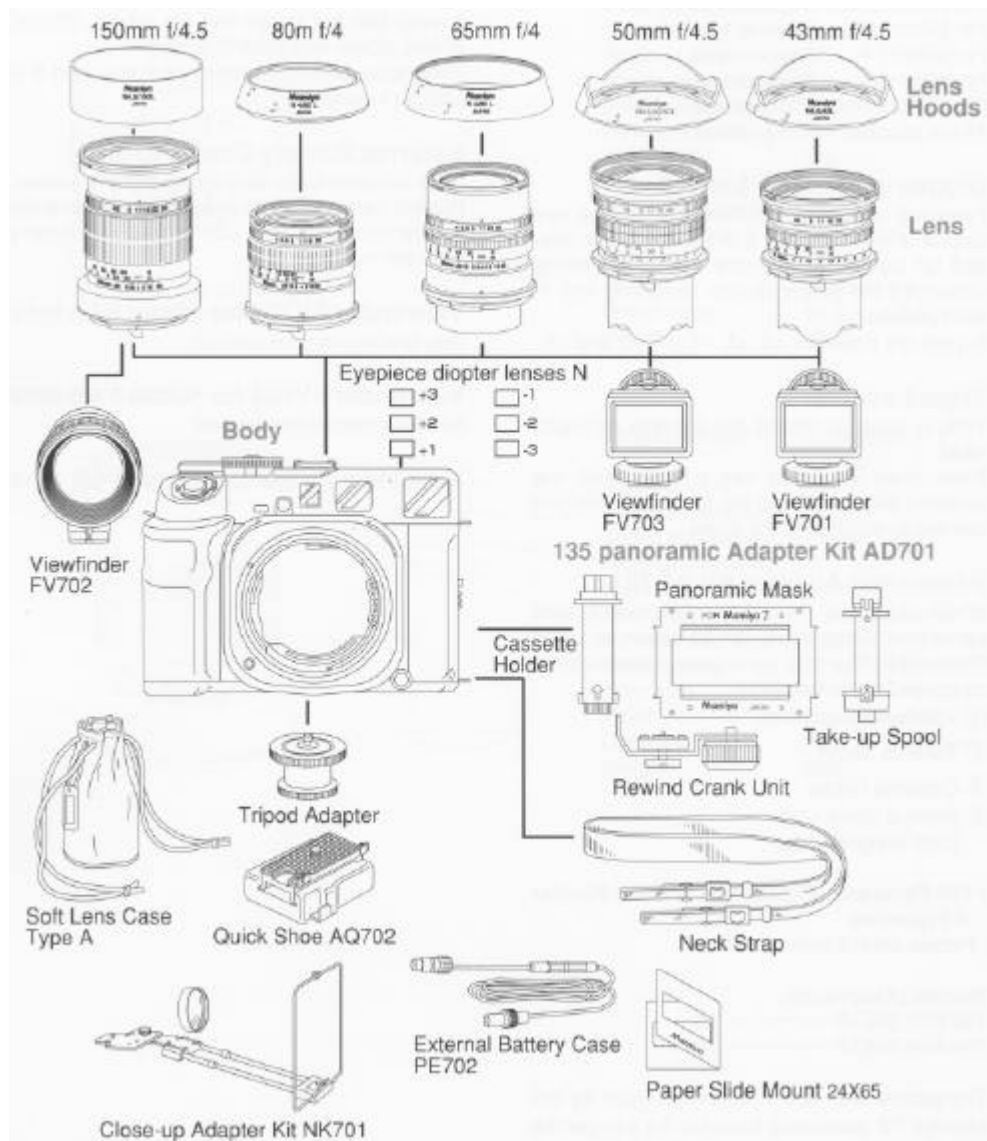

Specifications

Type of Camera	: 6 x 7cm format interchangeable lenses, rangefinder camera, double formats (6 x 7 and 35mm panorama)
Film Used	: 120 Roll Film (10 exposures), 220 Roll Film (20 exposures), 135 Roll Film (16 exposures with 36 exp. film)
Actual Image Size	: 56 x 69.5mm with 120/220 film, 24 x 65mm with 135 film, using Panoramic Adapter Kit
Film winding	: A single 185° stroke
Lens Mount	: Exclusive Bayonet Mount
Lenses	Ultra wide angle : 43mm f/4.5 L with Optical Viewfinder Wide angle : 50mm f/4.5 L with Optical Viewfinder, 65mm f/4 L Standard : 80mm f/4 L Telephoto : 150mm f/4.5 L
Shutter	: #00 electronic leaf shutter, B, 4 -1/500sec. ,electro-magnetic shutter release, X-contact synchronizing at all shutter speeds with hot shoe and PC Terminal; Electronic Self Timer (10 sec. delayed, automatic turn-off)
Multiple exposure Exposure Control	: Possible by means of multi-exposure lever. Aperture priority AE, SPD receptor in viewfinder metering range: EV3 - EV18 (with 80mm f/4 lens ISO 100), Exposure compensation: +2 - -2EV (in 1/3EV steps) Film speed range: ISO 25 - 1600
Rangefinder	: Lens declination, double image super imposing system: base length 60mm (effective base length 34.2mm)
Viewfinder	: Coupled with rangefinder: automatic bright line frame indexing (65, 80 and 150mm): parallax compensation: Magnification ratio: 0.57X: 83%* of the field of view visible at infinity: built - in shutter speed and exposure display, safety interlock warning L.E.D. *This information is based on a linear (horizontal/vertical) measurement.
Internal "Dark Slide" Curtain	: To permit changing lenses with loaded camera
Safety Mechanism	: 1. Double exposure prevention 2. Shutter release is locked when internal dark slide curtain is engaged. 3. Shutter release button lock lever
Power Supply	: one 6V (4SR44, 4LR44 or 2CR1/3 lithium) battery
Dimensions	: Camera body: 159(L) x 112(H) x 66(D)mm Body with 80mm lens: 159(L) x 112(H) x 120(D)mm
Weight	: Camera body: 920g Body with 80mm lens: 1,210g

***Specifications and features are subject to change without notice.**

Common Sense Camera Care and Practice

The Mamiya 7II is a precision optical/mechanical instrument, built for heavy professional use and a long service life, if properly treated and maintained. Please observe these basic caveats:

- Read instructions before using camera.
- Protect camera against shocks and falls. Use neck strap supplied with it, whenever possible.
- Check the battery frequently and always carry spares. The sealed battery supplied with the camera may have been subject to storage conditions which have reduced its service life.
- Be sure to wipe battery contacts before installation and watch correct polarity.
- Battery life differs, depending on frequency of use, type, age, storage condition, ambient temperature (use External Battery Case in very cold weather), etc.
- Always remove the battery (and film) when camera is not used for a period of time.
- Always keep covers on lenses and camera body.
- Do not store the camera at temperatures exceeding 40°C (105°F) and -10°C (15°F). Also avoid humid or sea air environment.
- Prolonged disuse shortens camera life. Periodically exercise the shutter (at different speeds, lens diaphragms and focusing mounts).
- Protect camera against rain and moisture.
- Do not touch lens surfaces. Use blower or lens tissue to remove dust particles.

Specific Suggestions:

- Operate the film advance lever with easy strokes. If moved too rapidly it may affect spacing.
- Hold lens focusing mounts on bottom in order not to block range finder window.
- Always test your equipment before going on important assignments.

The Importance of Proper Maintenance

Your camera has mechanisms like film transport, shutter and diaphragm blades, rangefinder couplings, etc. They are controlled by gears, levers, springs, and so on. All require special lubrication from time to time. Ambient conditions can also affect these mechanisms, as well as the electronic components and the optical glass of your lenses. We therefore suggest that you have your camera and lenses checked, and if necessary serviced, periodically.

Batteries Care

1. The sealed, new battery which is supplied with this camera may have been subject to storage conditions which have reduced its service life. Therefore it is desirable to replace it with a fresh battery as soon as possible.
2. Carefully wipe the battery contacts before inserting into the chamber. Failure to do so may result in poor electrical contact and consequent malfunctioning of the camera.
3. Always remove battery when camera is not used for a while. Always carry spare batteries.
4. Battery life differs, depending on type, age, storage condition, ambient temperature, frequency of use etc.
5. Be sure to match the poles of the battery with those shown in the diagram in the chamber.
- 6 Always keep batteries out of the reach of children and never throw used batteries into a fire or expose to excessive heat.
7. When going on trips be sure to carry spare batteries to ensure that the camera will function. Also, as batteries tend to temporarily malfunction at temperatures below freezing, when photographing in extremely cold climates, carry the External Battery Case.
8. When you carry spare batteries, leave them in the original factory packaging. If they are "unpacked", be sure to wrap them carefully in order to prevent them touching each other or any metal objects which can cause them to short circuit and become useless.

Free Manuals Download Website

<http://myh66.com>

<http://usermanuals.us>

<http://www.somanuals.com>

<http://www.4manuals.cc>

<http://www.manual-lib.com>

<http://www.404manual.com>

<http://www.luxmanual.com>

<http://aubethermostatmanual.com>

Golf course search by state

<http://golfingnear.com>

Email search by domain

<http://emailbydomain.com>

Auto manuals search

<http://auto.somanuals.com>

TV manuals search

<http://tv.somanuals.com>