

PLAY IT SAFE!

**OPERATION, MAINTENANCE
AND INSTALLATION MANUAL**

FOR

VERTICAL RECYCLER BALER

V-4224

CE RATED MODEL



A DOVER COMPANY

**VERNON, AL - FAYETTE, AL
YERINGTON, NV - CLEARFIELD, PA**

Marathon Equipment Co. OMI Manual No. 0011CE, Rev. 02/02

CONTENTS

SECTION 1 - Operation

Introduction	1-1
EC Declaration of Conformity.....	1-2
Pre-Operating Instructions	1-3
Controls	1-4
Control Description	1-5
Operating Instructions	
Making A Bale	1-6
Bale Tie Off/Bale Eject	1-7
Diagram	1-8
Tie Slot Cleaning	1-9
Decals	1-10
Decal Placement	1-11

SECTION 2 - Maintenance

Lock-Out & Tag-Out Instructions	2-1
Supporting Of Platen	2-2
Periodic Maintenance	2-3
Pressure Setting	2-4
Interlock Testing	2-5
Cylinder Removal And Rebuilding	2-6
Feed Gate Latch Adjustment	2-7
Principles Of Operation	2-8
Charts	2-9
Panel Box	2-10
Power Unit	2-11
Electrical Schematic	2-12
Hydraulic Schematic	2-13
Parts List	2-14
Recommended Oil	2-14
Motor Warranty	2-14

SECTION 3 - Installation

General Installation	3-1
Anchoring To Concrete Pad	3-2
Electrical Installation	3-3
Start-Up Instructions	3-4

INTRODUCTION

THANK YOU FOR PURCHASING A MARATHON VERTICAL BALER.

This product is designed to give you reliable service and superior performance for years to come. To guarantee top performance and the safest operation of the baler, each person involved in the operation, maintenance and installation of the baler should read and thoroughly understand the instructions in this manual and follow all warnings.

The employer(s) involved in the operation, maintenance and installation of the baler should read and understand the most current version of the following applicable standards:

ANSI Standard No. Z245.5, "Safety Requirements For Baling Equipment"

A copy of this standard may be obtained from:

Environmental Industries Association

4301 Connecticut Avenue, N.W.

Suite 300

Washington, D.C. 20008

Telephone: 1-202-244-4700

OSHA 29 CFR, Part 1910.147, "The control of hazardous energy (lockout/tagout)"

ALL SERVICE OR REPAIR PROCEDURES DESCRIBED IN THIS MANUAL SHOULD BE PERFORMED BY AUTHORIZED, FULLY TRAINED PERSONNEL.

Any service or repairs that go beyond the scope of this manual should be performed by factory authorized personnel only.

IF YOU SHOULD NEED FURTHER ASSISTANCE, PLEASE CONTACT YOUR DISTRIBUTOR. YOU WILL NEED TO PROVIDE THE BALER SERIAL NUMBER, INSTALLATION DATE, AND ELECTRICAL SCHEMATIC NUMBER TO YOUR DISTRIBUTOR.

IF YOU HAVE ANY SAFETY CONCERNS WITH THE EQUIPMENT, OR NEED FURTHER INFORMATION, PLEASE CONTACT US AT:

Marathon Equipment Company

P.O. Box 1798

Vernon, AI 35592-1798

Attn: Field Service Department

1-800-633-8974



P.O. Box 1798
Vernon, AL 35592-1798
800-633-8974
205-695-9105

<http://www.marathonequipment.com>

EC DECLARATION OF CONFORMITY

The Supply of Machinery (Safety) Regulations 1992

Pursuant to The Council of The European Communities Directive 89/392/EEC, as amended by 91/36P/EEC

The Machine/Installation:
PRODUCT: V-4224 Vertical Recycler Baler
SERIAL NUMBER: As specified for EC export
YEAR OF MANUFACTURE: 2006

The above has been developed, designed and manufactured in accordance with the above relevant statutory provisions by:

Marathon Equipment Company

950 County Road
Vernon AL, USA 35592

The following harmonized standards have been applied:

1991 EN 292/1 and EN 292/2, Safety of machines, devices and installations
1992 EN 418, Safety of Machinery, Emergency Stop Equipment, Functional Aspects.
Principals for Design
1992 EN 294, Safety distance to prevent access to danger zones
1993 EN 60 204-1, Safety of Machinery, Electrical Equipment of Machines
1993 EN 349, Safety of Machinery, Minimum Gaps to Avoid Crushing Parts of the
Human Body
1996 BS EN 982, Safety Requirements of fluid systems and components
1997 BS EN 1050, Safety of Machinery, Principles for Risk Assessment
1998 BS EN 953, Safety of machinery, Guards.

Technical documentation is available upon request.

The operating manual for the machine/installation is provided.

(*) in the language of the country of manufacture

(*) in the national language of the user

THIS DECLARATION WILL BECOME INVALID IF, FOLLOWING HAND OVER, THE MACHINE/INSTALLATION IS ALTERED IN ANY WAY.

1 OPERATION

PRE-OPERATING INSTRUCTIONS



**STAND CLEAR WHILE
BALER IS IN OPERATION.**

WARNING: DO NOT OPERATE BALER UNTIL OPERATING INSTRUCTIONS ARE THOROUGHLY UNDERSTOOD.

NEVER ENTER ANY PART OF THE BALER UNLESS THE DISCONNECT SWITCH HAS BEEN TURNED OFF AND PADLOCKED. Before starting the baler, be sure no one is inside. Be certain that everyone is clear of all points of operation and pinch point areas before starting. See **Lock-Out & Tag-Out instructions in the Maintenance section.**



THE EMPLOYER SHOULD ALLOW ONLY AUTHORIZED AND TRAINED PERSONNEL TO OPERATE THIS BALER. This baler is equipped with a key operated locking system. The key(s) should be in the possession of only authorized personnel. Turn off and remove key after use.

Federal regulation prohibits operation by persons under 18 years of age.

BE CERTAIN TURNBUCKLE AND LATCH IS FULLY LOCKED IN PLACE ON BALE CHAMBER DOOR BEFORE STARTING BALER.

Pay close attention to the **RED WARNING LIGHT** on the control panel. If the light is illuminated when the feed gate is raised, there is a malfunction of the magnetic interlock system. **IN THIS EVENT, DISCONTINUE USE OF THE BALER AND LOCK-OUT & TAG-OUT THE BALER PER THE INSTRUCTIONS IN THE MAINTENANCE SECTION, PAGE 2-1.** Perform necessary repairs before continuing operation of the baler.

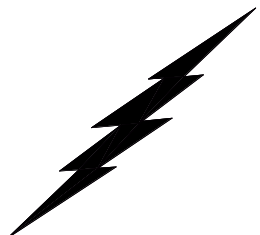

ONLY AUTHORIZED PERSONNEL SHOULD BE ALLOWED INSIDE THE PANEL BOX. The panel box contains high voltage components. See **Lock-Out & Tag-Out instructions in the Maintenance section.**



CONTROLS

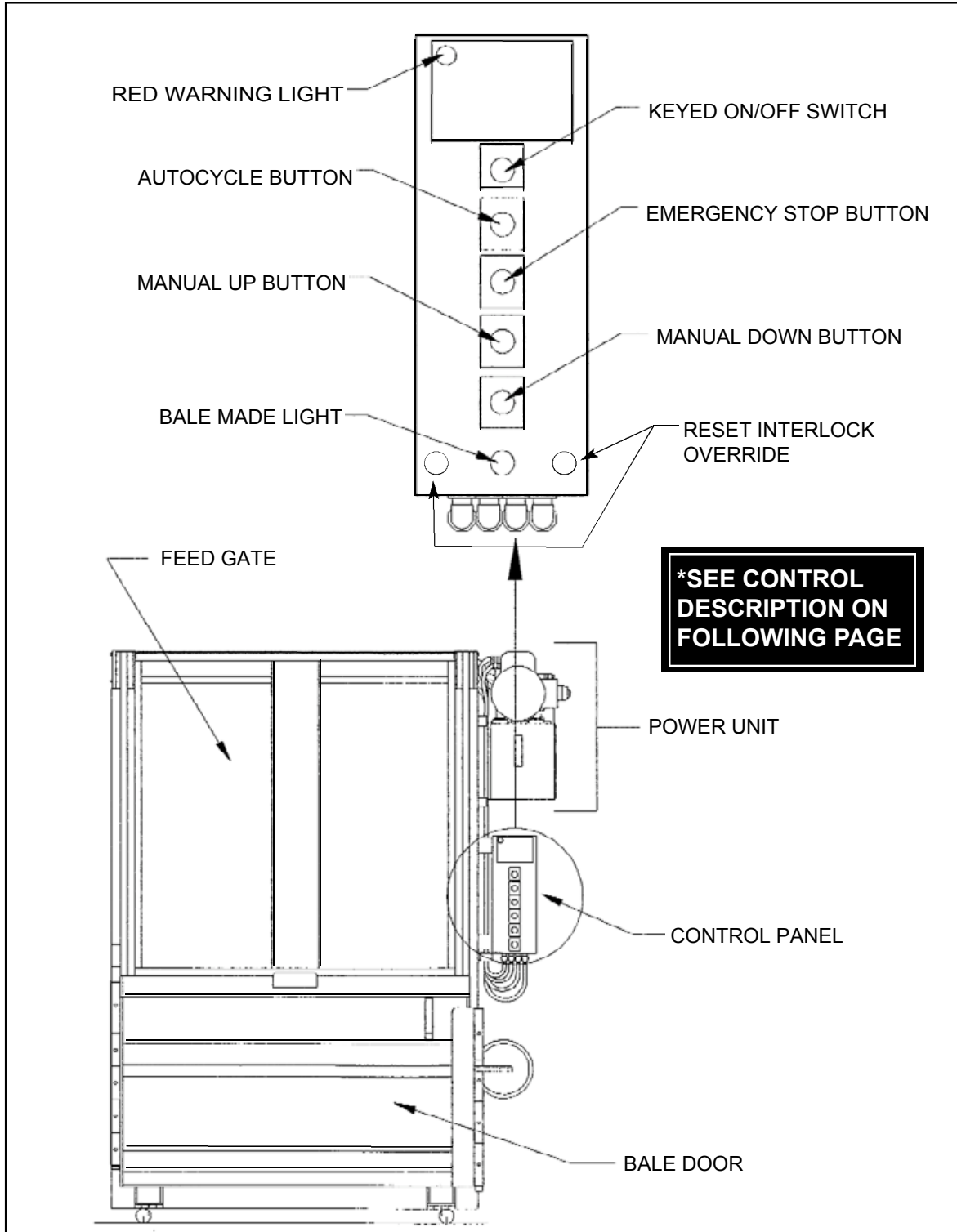

CONTROL DESCRIPTION

1. **ON-OFF (Keyed Selector Switch)**

Turning this switch to the ON position activates the other controls in the control panel. The baler can not be operated unless the key is in the switch and the switch is in the ON position. The purpose of this switch is to allow only authorized and trained personnel to operate the baler. The key should be removed from the baler when not in use and should stay in the possession of only responsible and trained personnel.

2. **EMERGENCY STOP (Red Mushroom Head Pushbutton)**

Depressing this button will stop the machine at any point in the cycle.

3. **AUTOCYCLE (Green Pushbutton)**

The AUTOCYCLE button can be used only when the feed gate and bale door are closed and the keyswitch is in the ON position. Once depressed, the AUTOCYCLE button will cause the platen to move to the fully down position and back to the fully raised position (one complete cycle).

4. **MANUAL UP (Black Pushbutton)**

This button will only start the baler with the keyswitch in the ON position. Depressing this button will raise the platen with the feed gate and bale door opened or closed. It is normally used during bale ejection. It can also be used to interrupt the automatic cycle and raise the platen should it become necessary. The MANUAL UP button is a "Hold To Run" control, causing the baler to stop when it is released. **WARNING: STAY CLEAR OF MOVING PARTS WHEN USING THE MANUAL UP BUTTON WITH THE FEED GATE OPEN.**

5. **MANUAL DOWN (Black Pushbutton)**

This button will only start the baler with the keyswitch in the ON position. Depressing this button will lower the platen only if the feed gate and bale door are closed. It can be used to interrupt the automatic cycle and lower the platen should it become necessary. The MANUAL DOWN button is a "Hold To Run" control, causing the baler to stop when it is released.

6. **RED WARNING LIGHT**

This light will warn the operator of a magnetic interlock switch malfunction. If the light is on, and the feed gate is in the up position, there is a problem. Discontinue use of the baler. Turn off the baler and Lock-out and Tag-out per the instructions on page 2-1. Then call a qualified service person. The light SHOULD BE ON when the feed gate is in the down position.

7. **BALE MADE LIGHT**

This light will come on if enough material has been compacted to make a complete bale.

1 OPERATION

OPERATING INSTRUCTIONS - MAKING A BALE

WARNING: DO NOT OPERATE BALER UNTIL OPERATING INSTRUCTIONS ARE UNDERSTOOD. See page 1-4 for control panel layout.



**IN CASE OF EMERGENCY:
Push the large red button to
STOP**

WARNING: Interlocks and safety devices were installed on this unit for your protection. **Never disable or bypass any interlock or safety device.** Failure to comply with this warning could result in serious injury or death.

TO MAKE A BALE :

1. **Feed material into baler.** If starting a new bale, place a large flat piece of material flat on the baler floor. NOTE: Do not attempt to overfill the feed chamber by forcing material into the chamber with the feed gate. This can cause gate release malfunction and may damage baler.
2. **Pull gate handle down to close feed gate.** NOTE: Check red warning light before closing feed gate. If gate is open and light is on, discontinue use of the baler and call for service.
3. **To start the baler, insert the key into the keyswitch and turn to the ON position.**
4. **Press the AUTOCYCLE button.** The platen will make a complete cycle down and back up. When the platen is in the full up position, the feed gate will automatically open and the motor will automatically shutdown.
5. Repeat steps 1 through 4 until the platen stops in the down position, and the "BALE MADE" light comes on.

NOTE: In normal operation, the feed gate will be open when you walk up to place material into the baler. For added security, the feed gate can be manually closed after the AUTOCYCLE(S). To open the gate, you will have to insert the key into the keyswitch and run the baler through a complete AUTOCYCLE.

OPERATING INSTRUCTIONS - BALE TIE OFF/BALE EJECT

When the "BALE MADE" light comes on it is time to tie off the bale and eject the bale from the baler. See page 1-4 for control panel layout and location. See the following page for a diagram of the following steps.

FOR BALE TIE OFF & BALE EJECT:

1. Press the MANUAL UP button until the platen is in the up position and the feed gate raises.
2. Insert a large, flat piece of material across the top of the bale. With the platen in the "up" position, make sure there is no cardboard, or other baled materials, stuck between the back of the platen and the back wall of the baler. Remove any materials found in this area.
3. Close feed gate and press the AUTOCYCLE button. The platen will move to the down position and the BALE MADE light will come back on.
4. Release the bale chamber door latch on the side of baler and open the bale chamber door all the way. Feed gate is closed but will raise when the bale chamber door is opened.
5. **CAUTION: Wear safety glasses and leather gloves during the following operation:** Facing the front of the bale, tie off bale by inserting bale ties (loop end first) through the platen. **Always insert bale ties through the tie slots in the platen, first.** Feed wire through until it comes out of the tie slot in the baler floor. Tie off each tie. Bale ties should be tightened only hand tight, allowing for bale expansion when released. **See Diagram on Following Page.**
6. Standing at the side, make sure all personnel are clear of the front of the baler. Press and hold the MANUAL UP button until the bale ejects.
7. Remove bale from in front of baler. Close and latch the bale door **completely**. Failure to close and latch the bale door completely may result in serious damage to the bale ejector.
8. Close the feed gate, and press the AUTO CYCLE button and let the machine run through a complete cycle to reset the bale ejector hook. When the feed gate raises, the machine is ready to start the next bale.

NOTE: You can close the feed gate at this time if added security is required. To open the gate you will have to run the baler through a complete AUTOCYCLE.

1 OPERATION

DIAGRAM - BALE TIE OFF/BALE EJECT

FRONT VIEW OF BALER

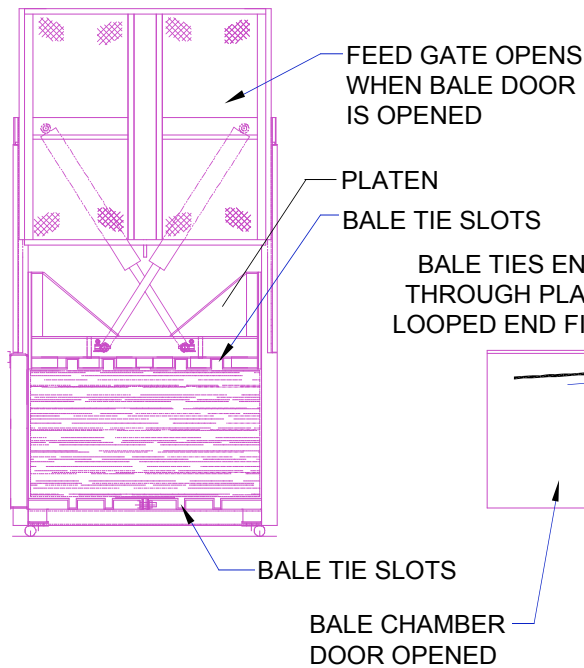

SIDE VIEW

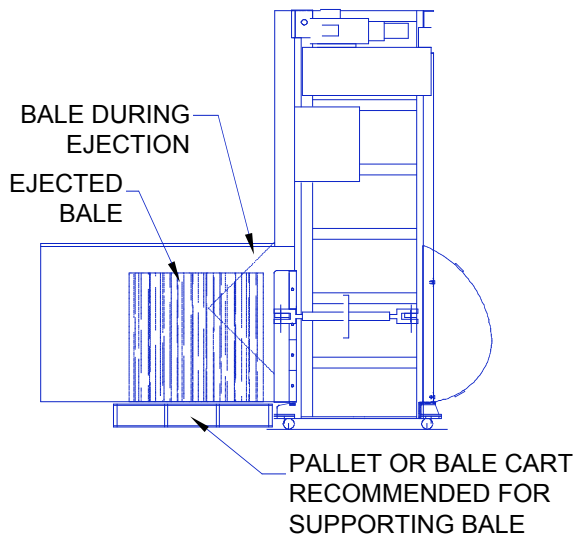
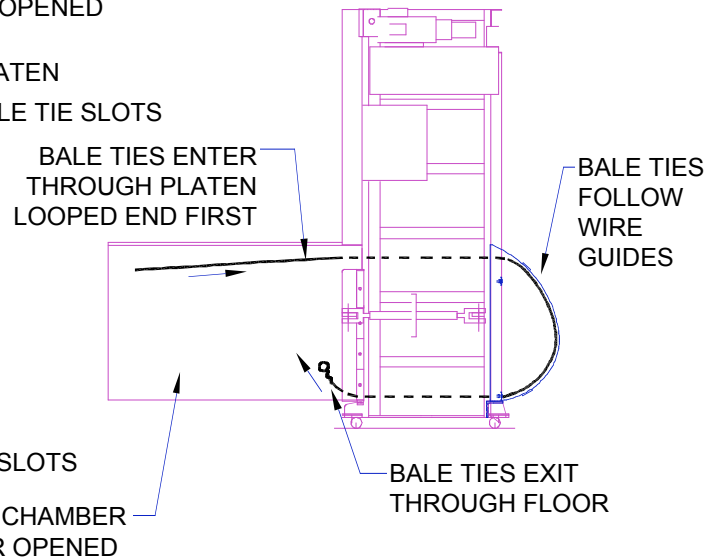

BALE TIE - TIGHTENED HAND TIGHT

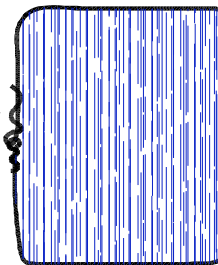

SIDE VIEW - BALE

1 OPERATION

TIE SLOT CLEANING

AT TIMES THE TIE SLOTS MAY BECOME OBSTRUCTED WITH MATERIAL AND PREVENT THE WIRE TIES FROM PROPER INSERTION THROUGH THE SLOTS AND AROUND THE BALE. THE BALER IS SUPPLIED WITH A **SLOT CLEANING TOOL** FOR RODDING OUT THE TIE SLOTS. TO USE, INSERT THE TOOL INTO THE BLOCKED SLOT AND PUNCH OR DRAG THE MATERIAL OUT.

IF THE WIRE GUIDES BECOME OBSTRUCTED WITH MATERIAL , THE BALER SHOULD BE EMPTIED, **LOCKED OUT AND TAGGED OUT**, AND THE PLATEN SHOULD BE CHOCKED AS SHOWN IN THE MAINTENANCE SECTION OF THIS MANUAL (2-2) BEFORE CLEANING THE WIRE GUIDES.

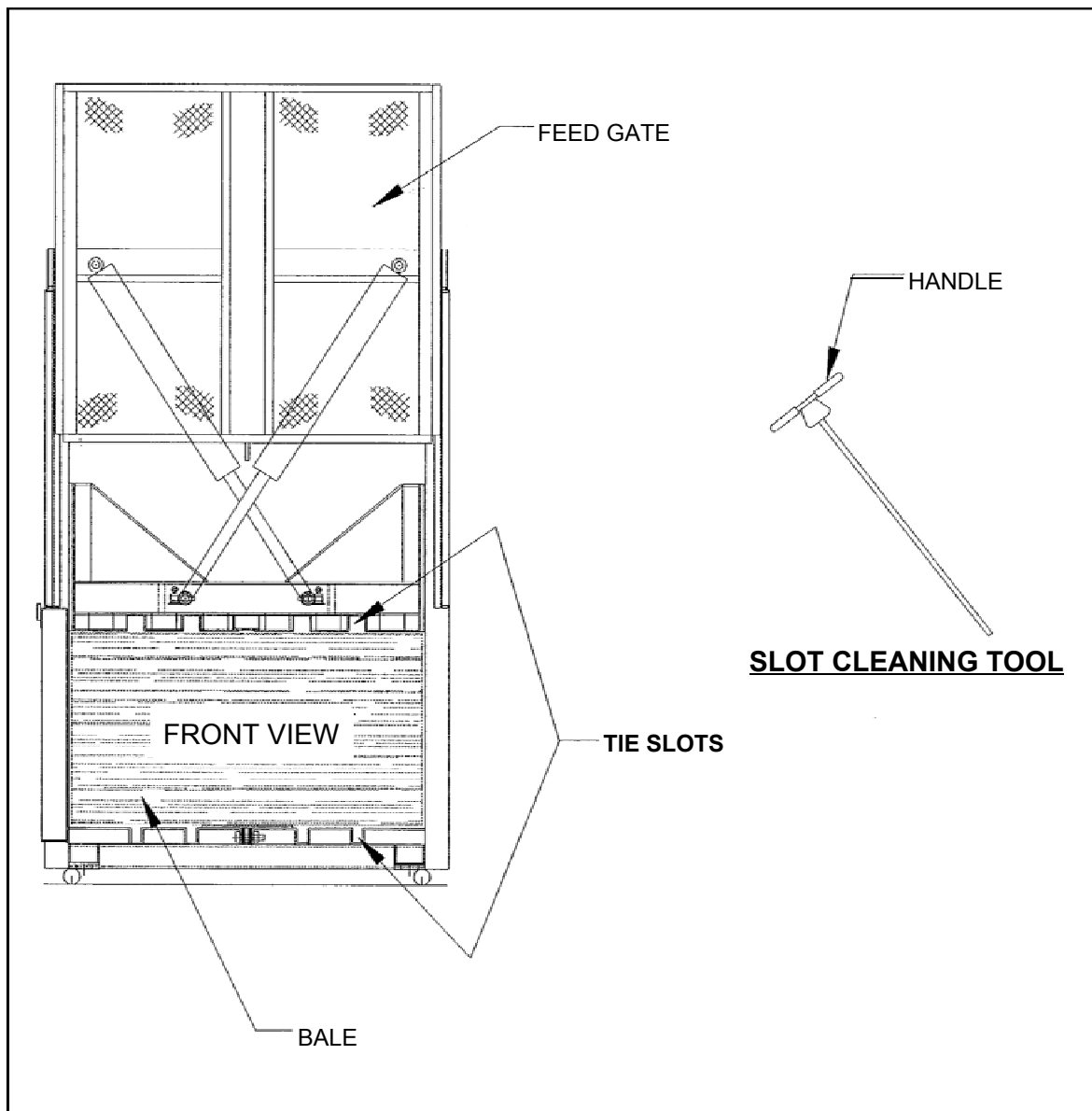

1 OPERATION

DECALS

WARNING DECAL REQUIREMENTS

When your baler leaves the factory, several WARNING DECALS are installed for protection. These labels are subject to wear and abuse due to the nature of the operation. **THESE DECALS MUST BE MAINTAINED.** Additional decals may be purchased through your distributor.

REFERENCE NUMBER	PRODUCT NUMBER	QUANTITY	DESCRIPTION
1	06-2682	1	MARATHON LOGO/A DOVER COMPANY
2	06-3309	6	CE RATED DANGER STRIPE (275mm)
3	06-2582	1	NO ACCESS FOR UNAUTHORIZED PERSONS
4	06-2755	1	DO NOT ENTER/CONFINED SPACE
5	06-0419	1	READ MANUAL
6	06-0130	2	OPERATING INSTRUCTIONS
7	06-2702	1	PINCH POINT/MOVING PARTS
8	06-2681	3	HOT SURFACE/BURN HAZARD
9	06-0468	1	CE MODEL/SERIAL NUMBER
10	06-2757	1	ELECTRICAL LOCKOUT
11	06-2758	1	ELECTRICAL SHOCK HAZARD

See next page for Decal Placement.

DECAL PLACEMENT

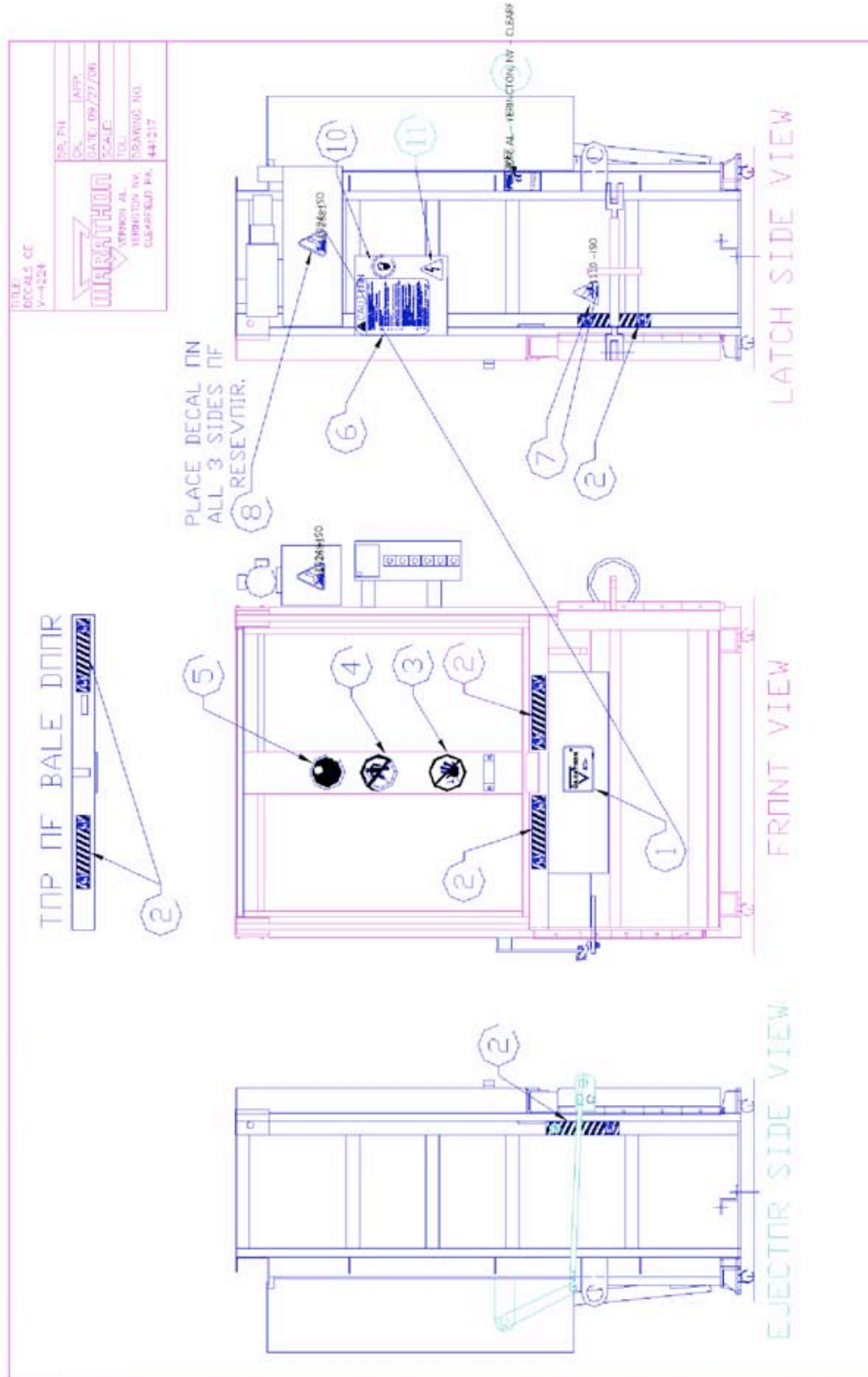

USE REFERENCE NUMBERS ON PREVIOUS PAGE TO MATCH PRODUCT NUMBERS WHEN REORDERING DECALS

LOCK-OUT & TAG-OUT INSTRUCTIONS

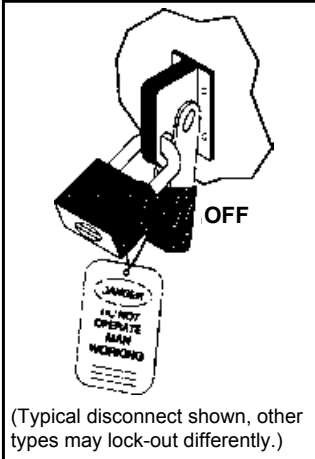

FOREWORD: Before entering any part of the baler, be sure that all sources of energy have been shut off, all potential hazards have been eliminated, and the baler is locked-out and tagged-out in accordance with OSHA and ANSI requirements. Before servicing the hydraulic system or the inside of the bale chamber, **THE PLATEN MUST BE PROPERLY SUPPORTED AS SHOWN ON THE NEXT PAGE.** The specific lock-out and tag-out instructions may vary from company to company (i.e. multiple locks may be required, or other machinery may need to be locked-out and tagged-out). The following instructions are provided as minimum guidelines.

INSTRUCTIONS

1. Move the main disconnect lever to the **OFF** position.
2. Padlock the disconnect lever with a keyed padlock and take the key with you.
3. Along with the padlock, place an appropriate, highly visible, warning tag on the disconnect lever. The tag should provide a warning such as: “ Danger: Do not operate equipment. Person working on equipment. Warning: Do not energize without the permission of _____.”
4. After locking and tagging the baler, try to start and operate the baler (as outlined in the Operating Instructions) to make sure the lock-out and tag-out is effective. If the lock-out and tag-out is effective, remove the key from the keyswitch and take with you.

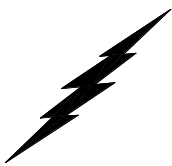

ELECTRICAL: The panel box contains high voltage components. Only authorized service personnel should be allowed inside the box. Authorized service personnel should be allowed inside the box only after the baler has been locked-out and tagged-out.

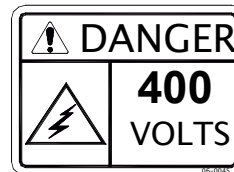

HYDRAULIC: Stored hydraulic energy must be removed from the baler hydraulic circuit for complete lock-out and tag-out. Make sure that this energy has been relieved by manually depressing the solenoid valve pin located in the center of the coil end of each valve. See Diagrams on pages 2-4 and 2-11.

2 MAINTENANCE

SUPPORTING OF PLATEN

WARNING: BEFORE ENTERING BALE CHAMBER FOR SERVICE, BE SURE THAT THE PLATEN IS SECURELY SUPPORTED. AT A MINIMUM, USE TWO WOODEN 100mm x 100mm BEAMS (GOOD CONDITION), CUT TO FIT SNUG IN EACH REAR CORNER OF THE CHAMBER WHILE SUPPORTING THE PLATEN IN THE UP POSITION. THE TOP END OF EACH BEAM SHOULD BE IN THE EXTREME CORNER, WHILE THE BOTTOM END SHOULD BE POSITIONED OVER THE OUTER TIE SLOT IN THE FLOOR. SEE DIAGRAM BELOW.

DANGER: DO NOT CLIMB ON SIDES OF BALER. USE A LADDER OR WORK PLATFORM WHEN WORKING ON TOP OF THE BALER OR OTHER AREAS OF THE BALER THAT CANNOT BE REACHED FROM GROUND LEVEL.

WARNING: FEED GATE WILL EXTEND ABOVE THE TOP OF THE BALER WHEN THE FEED GATE IS RAISED.

CAUTION: TURN DISCONNECT TO THE OFF POSITION, LOCK-OUT AND TAG-OUT POWER BEFORE SUPPORTING THE PLATEN.

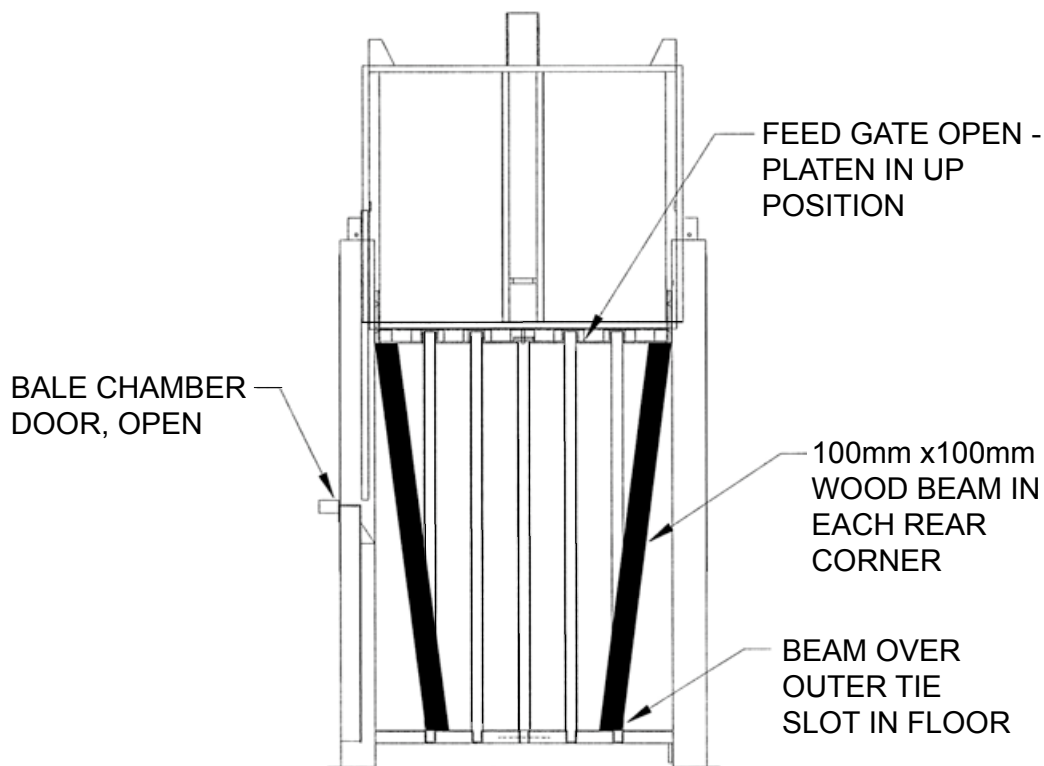

FRONT VIEW OF BALER

2 MAINTENANCE

PERIODIC MAINTENANCE

WARNING: BEFORE PERFORMING ANY MAINTENANCE OR SERVICE PROCEDURES ON THE BALER, MAKE SURE THE BALER IS LOCKED-OUT AND TAGGED-OUT PER THE INSTRUCTIONS ON PAGE 2-1. FOR MAINTENANCE INSIDE THE BALE CHAMBER, SEE THE PLATEN CHOCKING PROCEDURE ON PAGE 2-2.

MONTHLY

1. Check external hoses for chafing, rubbing, leakage, or other deterioration and damage. Tighten all fittings as necessary. Check hydraulic cylinder, cylinder pin and bolts for signs of wear and fatigue.
2. Check for any obvious unsafe conditions, such as operator obstructions, in baler area.
3. Check oil level in hydraulic reservoir.
4. Lubricate the door hinge, and mechanical door lock with oil.
5. Check magnetic interlock on feed gate for proper operation.
6. Apply a light coating of all purpose grease in the feed gate tracks.
7. Apply a light application of all purpose oil to the feed gate latch moving parts.
8. Remove any pieces of materials on top of the platen.

THREE MONTHS

1. Check functional operation of controls and options (stop button, timers, lights, etc.).
2. Check hydraulic cylinders, and hoses, for leakage, chafing and wear.

ANNUALLY

1. Replace the hydraulic fluid. See Recommended Oil (page 2-14).
2. Electric motor bearings should be lubricated once a year.
3. Clean the top of the power unit to remove the dirt build up.

ANNUAL FILTER MAINTENANCE

1. The hydraulic filter should be cleaned at regular annual intervals.
2. The filter may be removed from the power unit through the cleanout cover in the top of the reservoir.
3. Care should be exercised in cleaning the filter to insure that the element is not torn. Clean the element with a soft brush and standard industrial solvent.
4. Replace the filter after cleaning and check fittings for tightness. Pump noise and a "crackle" sound is most often caused by air entering the pump suction line. Tightening the suction fittings will usually eliminate the problem.

2 MAINTENANCE

PRESSURE SETTING

DANGER: DO NOT CLIMB ON SIDES OF BALER. USE A LADDER OR WORK PLATFORM WHEN WORKING ON TOP OF THE BALER OR OTHER AREAS OF THE BALER THAT CAN NOT BE REACHED FROM GROUND LEVEL.

WARNING: FEED GATE WILL EXTEND ABOVE THE TOP OF THE BALER WHEN THE FEED GATE IS RAISED.

HYDRAULIC SYSTEM PRESSURE SETTING

1. Using the "MANUAL DOWN" button, run the platen to the fully down position.
2. Lock-out and Tag-out the power per the instructions on page 2-1.
3. Relieve any stored hydraulic pressure by pressing in on the solenoid valve pins located on each end of the directional control valve. Use a small blade screwdriver or small allen wrench to perform this operation.
4. Remove the 1/4" plugs in the "A" and "B" port fittings where the hydraulic hoses enter the back of the baler, and install a pressure gauge in each port (2 gauges required).
5. Loosen the lock nut on the counterbalance valve and adjust the valve counter clockwise all the way out.
6. Remove the Lock-out and Tag-out.
7. Insert the key into the key switch and turn the key to the "ON" position.
8. Press the "MANUAL UP" button and raise the platen to the fully up position.
9. While continuing to hold the "MANUAL UP" button, loosen the lock nut on the Relief Valve and adjust the relief pressure to 150 psi. Use the pressure gauge in the "B" port to read this pressure. Release the "MANUAL UP" button.
10. Press the "MANUAL DOWN" button and adjust the counterbalance valve clockwise until the platen moves in the downward direction freely. Tighten the lock nut on the counterbalance valve.
11. Continue to hold the "MANUAL DOWN" button and adjust the Relief Valve to 650 psi. Use the pressure gauge in "A" port to read this pressure. Release the "MANUAL DOWN" button.
12. Remove the cap from the Unloading Valve adjustment screw located on the pump.
13. Press the "MANUAL DOWN" button again and adjust the unloading valve screw to unload the high flow section of the pump. Turning the screw clockwise increases the unloading pressure, while turning the screw counter clockwise decreases the unloading pressure. With the relief pressure at 500 psi., the pump will have a distinctive sound when the pump unloads. Replace the cap on the Unloading Valve adjustment screw.

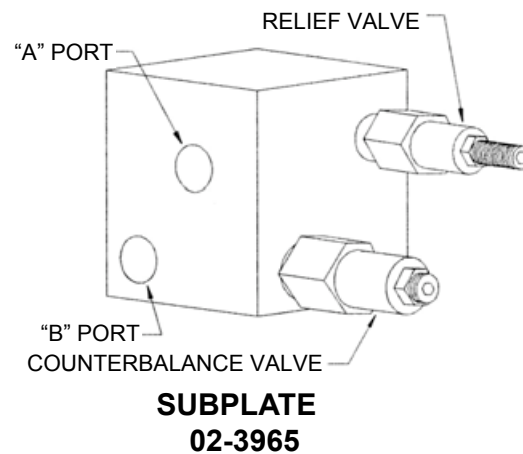

2 MAINTENANCE

PRESSURE SETTING AND INTERLOCK TESTING

DANGER: DO NOT CLIMB ON SIDES OF BALER. USE A LADDER OR WORK PLATFORM WHEN WORKING ON TOP OF THE BALER OR OTHER AREAS OF THE BALER THAT CAN NOT BE REACHED FROM GROUND LEVEL.

WARNING: FEED GATE WILL EXTEND ABOVE THE TOP OF THE BALER WHEN THE FEED GATE IS RAISED.

HYDRAULIC SYSTEM PRESSURE SETTING-(continued)

14. Continue to press the "MANUAL DOWN" button and adjust the Relief Valve to 1800 psi.
15. While holding 1800 psi. adjust the pressure switch until Relay 3 (R3) energizes.
16. Continuing to press the MANUAL DOWN button, adjust the relief valve to 2000 psi.
17. Tighten the lock nut on the Relief Valve.
18. Lock-out and Tag-out power per the instructions on page 2-1.
19. Relieve any stored hydraulic pressure by pressing in on the solenoid valve pins as described in Step 3.
20. Remove the pressure gauges from the "A" and "B" ports and reinstall the 1/4" plugs.
21. Remove the Lock-out and Tag-out and turn the power "ON". The pressure settings are now complete.

MAGNETIC INTERLOCK TESTING

1. This baler is equipped with a solid state output magnetic interlock switch. Because it is a semiconductor device, it can not be checked with a continuity light or OHM tester. The switch must be checked with the power ON. The RED WARNING LIGHT on the control panel has been provided to indicate if the switch is working properly.
2. To check the switch, turn the keyswitch to the ON position. When the feed gate or bale door is open, the light should be off. When the bale door and feed gate are closed, the light should be on.
3. If further verification is required, a voltmeter (120V) may be connected to terminal #2A and terminal #7 in the panel box. The meter should read "0" volts with the gate open and 120 volts with the gate closed.
4. In no instance should the baler operate in either MANUAL DOWN or AUTOCYCLE with the feed gate up or bale door open.

WARNING: IF THE INTERLOCK IS NOT WORKING PROPERLY, DISCONNECT THE POWER AND LOCK-OUT AND TAG-OUT THE BALER UNTIL REPAIRS CAN BE MADE.

CYLINDER REMOVAL AND REBUILDING

DANGER: DO NOT CLIMB ON SIDES OF BALER. USE A LADDER OR WORK PLATFORM WHEN WORKING ON TOP OF THE BALER OR OTHER AREAS OF THE BALER THAT CAN NOT BE REACHED FROM GROUND LEVEL.

WARNING: FEED GATE WILL EXTEND ABOVE THE TOP OF THE BALER WHEN THE FEED GATE IS RAISED.

CYLINDER REMOVAL

1. Close the feed gate.
2. Turn on power and lower the platen using the MANUAL DOWN button. Turn off power.
3. Disconnect and Lock-out and Tag-out power per instructions on page 2-1.
4. Open the bale door. When the bale door is opened, the feed gate will raise.
5. Support platen with fork lift to take pressure off of the cylinder pins and to prevent the platen from falling when pins are removed.
6. Remove bolts and cotter pins from the cylinder pins.
7. Remove platen from front of baler.
8. Turn on power and retract cylinder rods.
9. Disconnect and Lock-out and Tag-out power per instructions on page 2-1.
10. Relieve hydraulic pressure by manually depressing solenoid valve (both sides).
11. Relieve pressure on the counter balance valve. Loosen the locknut on the counterbalance valve and adjust the valve clockwise all the way in to relieve the pressure.
12. Disconnect one hydraulic hose at a time. Plug the hose port before disconnecting another hose.
NOTE: Remove hose fittings slowly.
- WARNING:** BE SURE HYDRAULIC CYLINDERS ARE SECURELY SUPPORTED BEFORE PROCEEDING.
13. With the hydraulic cylinders supported, remove the cylinder pins.
14. Remove cylinders.
15. Before reinstalling cylinders, check cylinder pins, bolts, and cylinder rods for signs of fatigue. Do not reuse parts if wear or cracks are present.
16. To reinstall the cylinders, reverse the above steps.
NOTE: Use new bolts, nuts, and cotter pins when re-installing the cylinder pins.
17. After reinstallation of cylinder(s), readjust pressure on the counter balance valve. See Page 2-4 for proper procedures.

CYLINDER REBUILDING

1. Remove hydraulic cylinder from baler.
2. Remove retainer nut from gland.
3. Remove internal retaining ring.
4. Remove rod from cylinder barrel.
5. Remove piston locknut and piston from cylinder rod.
6. Replace all seals. Discard old seals and old piston locknut.
7. Replace gland on rod.
8. Install piston on cylinder rod using new locknut (included in seal kit).
NOTE: Do not reuse old locknut. Torque new locknut to 275 - 330 ft-lbs.
9. Install piston and rod assembly in cylinder barrel. Be careful not to damage seals.
10. Install gland in barrel. Install internal retaining ring.
11. Install retainer nut to gland. Reinstall cylinder in baler.

FEED GATE LATCH ADJUSTMENT

NOTE: Adjustment is made by tightening or loosening the TENSION ADJUSTMENT NUT with the feed gate in the up position. Spring tension should not exceed 5 lbs to prevent excessive wear on the feed gate latch and striker.

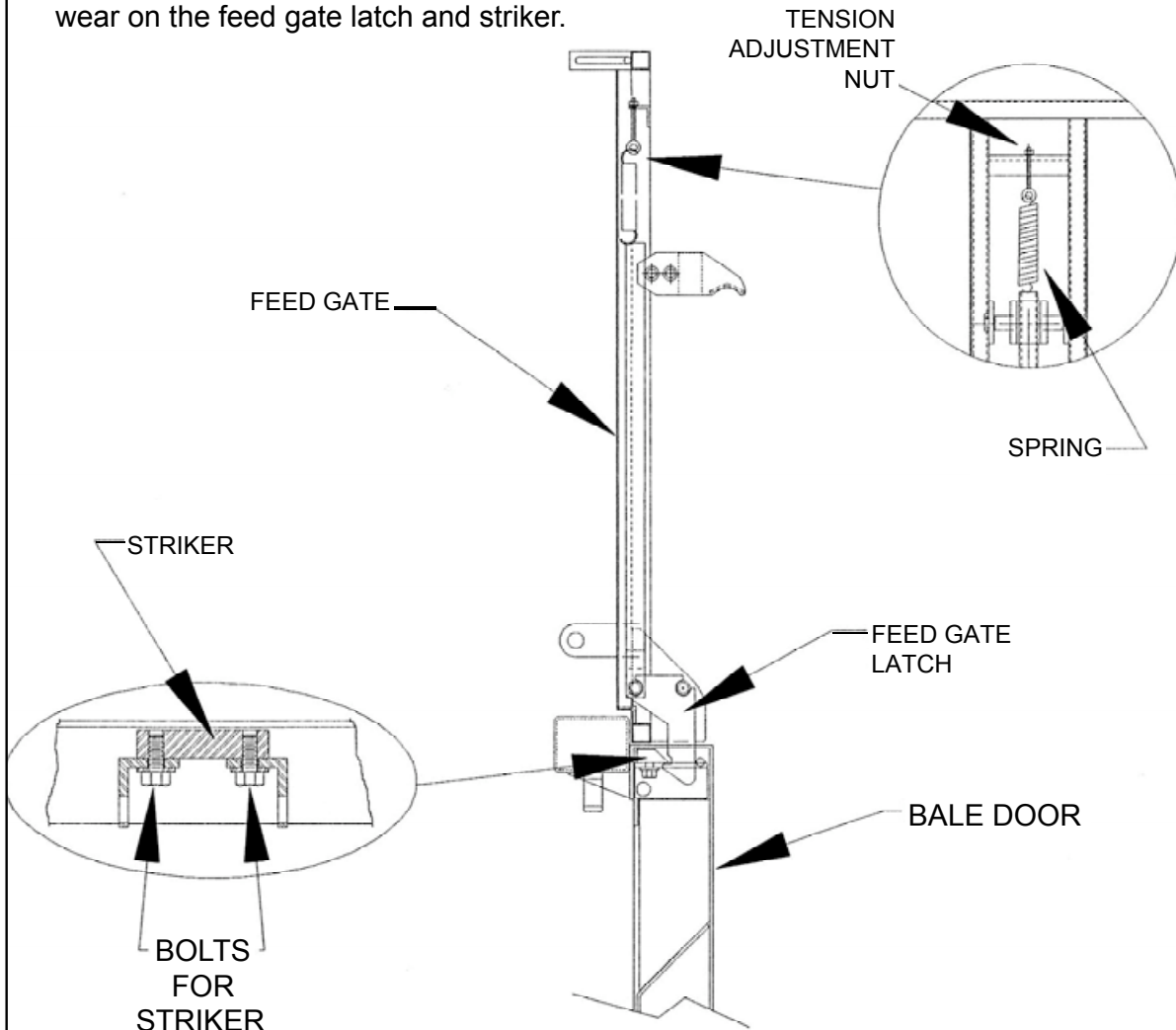

NOTE: In the event of excessive wear, the feed gate latch STRIKER is removable and replaceable. Striker may be replaced by removing the two (2) striker bolts. Access to the striker bolts can be achieved by removing the front cover from the bale door

PRINCIPLES OF OPERATION

OPERATING CHARACTERISTICS:

With the key switch in the ON position, and the bale door and feed gate closed, pressing the AUTOCYCLE push button will cause the machine to operate one complete cycle. Pressing the AUTOCYCLE switch closes three sets of contacts: (1) energizes Relay 1, (2) energizes Relay 2, (3) energizes the motor starter coil. With the motor running, oil is supplied to the subplate and directional control valve. With Relay 1 energized, oil is directed to the base end of the cylinders and causes the platen to move in the downward direction. The platen will move in the downward direction until enough pressure is detected by the pressure switch to de-energize Relay 1 and shift the directional control valve to direct the oil to the rod end of the cylinders and start the platen moving in the upward direction. When the platen raises high enough to catch and open the feed gate, the control voltage in the magnetic interlock switch is broken and deenergizes the motor starter and the power unit shuts down. When the motor starter is deenergized, an auxiliary contact de-energizes Relay 2.

When Relay 2 energizes, a contact is closed to start Timer 1. Timer 1 is used to shut the power unit down if the pressure switch never opens by either: (1) not enough pressure, or (2) by malfunction. Timer 1 sets at 50 seconds. If Timer 1 times out, Relay 2 is de-energized which deenergizes the motor starter coil. When the motor starter is de-energized, it also de-energizes Relay 1, and the power unit shuts down.

When enough material has been compacted in the bale chamber to stop the platen while holding the limit switch in the open position, and the pressure switch actuates, Relay 2 will deenergize. When Relay 2 de-energizes, the motor starter coil will de-energize, the power unit will shut down, and the BALE MADE LIGHT will come on.

NOTE: When the **BALE MADE LIGHT** comes on, it is time to tie the bale. See Bale Tie Off instructions on **page 1-7**.

2 MAINTENANCE

CHARTS

ELECTRICAL REQUIREMENTS

5 HP 400V 3 PHASE 50HZ			
VOLTAGE	208 VAC	230 VAC	400 VAC/50 HZ
FULL LOAD AMPERAGE	16.7	15.2	8.5
DISCONNECT SIZE (MAX)	30 AMP	30 AMP	30 AMP
TIME DELAY FUSE (MAX)	30 AMP	25 AMP	15 AMP
INVERSE TIME CIRCUIT BREAKER (MAX)	40 AMP	40 AMP	20 AMP
<u>WIRE SIZE (75 °C)</u>			
20 m	12	12	12 AWG/ 4mm ²
30 m	10	10	12 AWG/ 4mm ²
60 m	6	8	12AWG/ 4mm ²
90 m	4	6	10AWG/ 6mm ²

2 MAINTENANCE

PANEL BOX

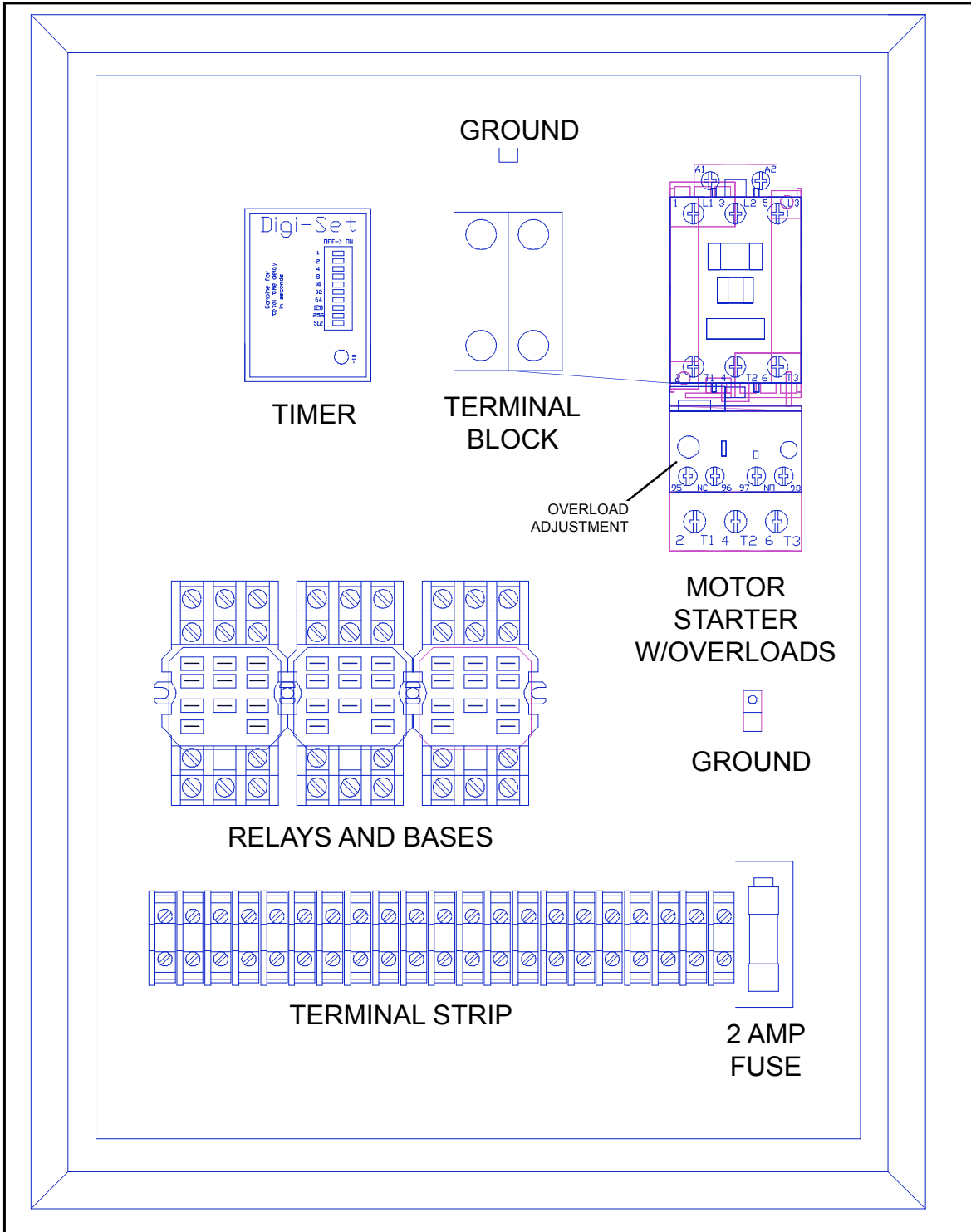

POWER UNIT

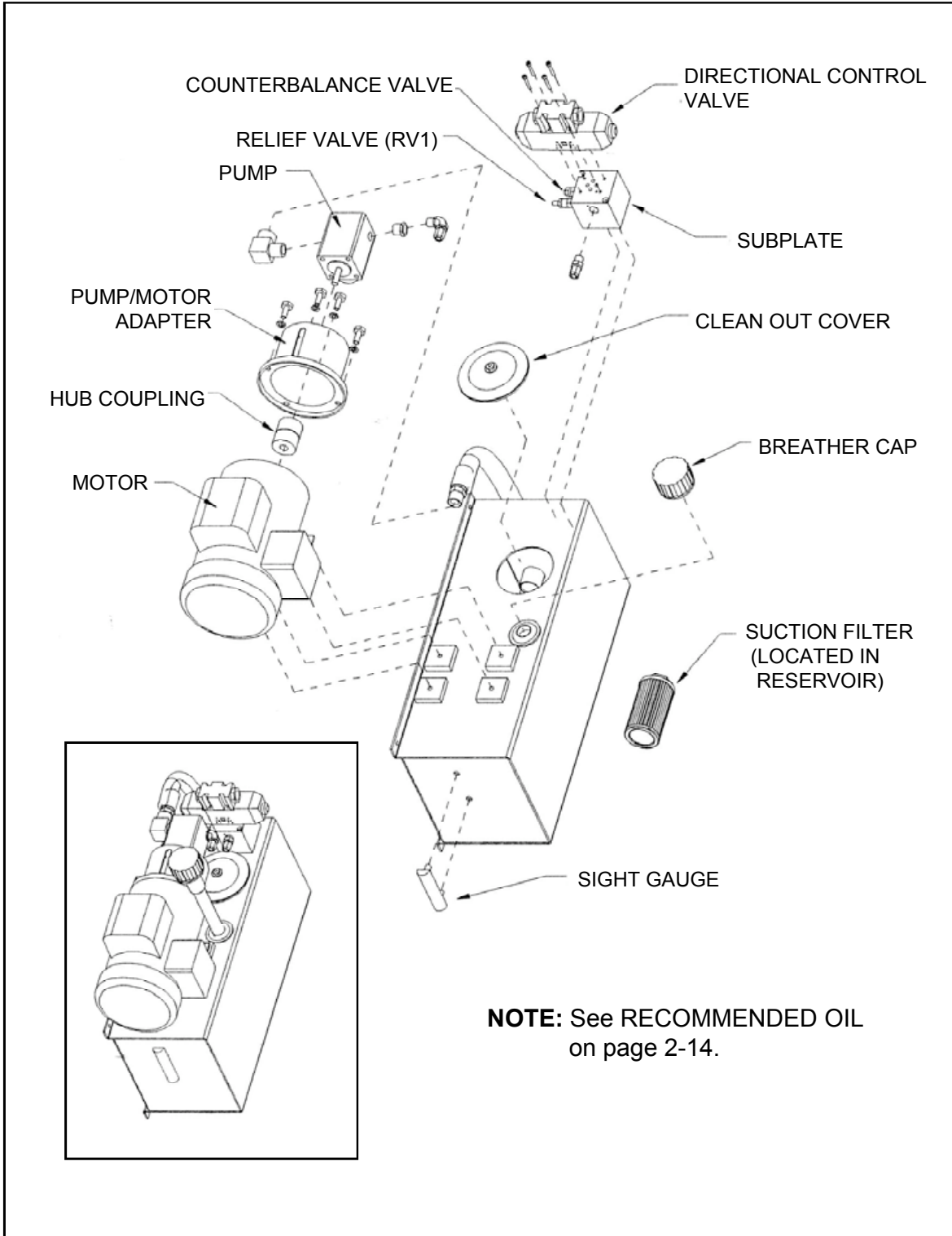

2 MAINTENANCE

ELECTRICAL SCHEMATIC

E-6415

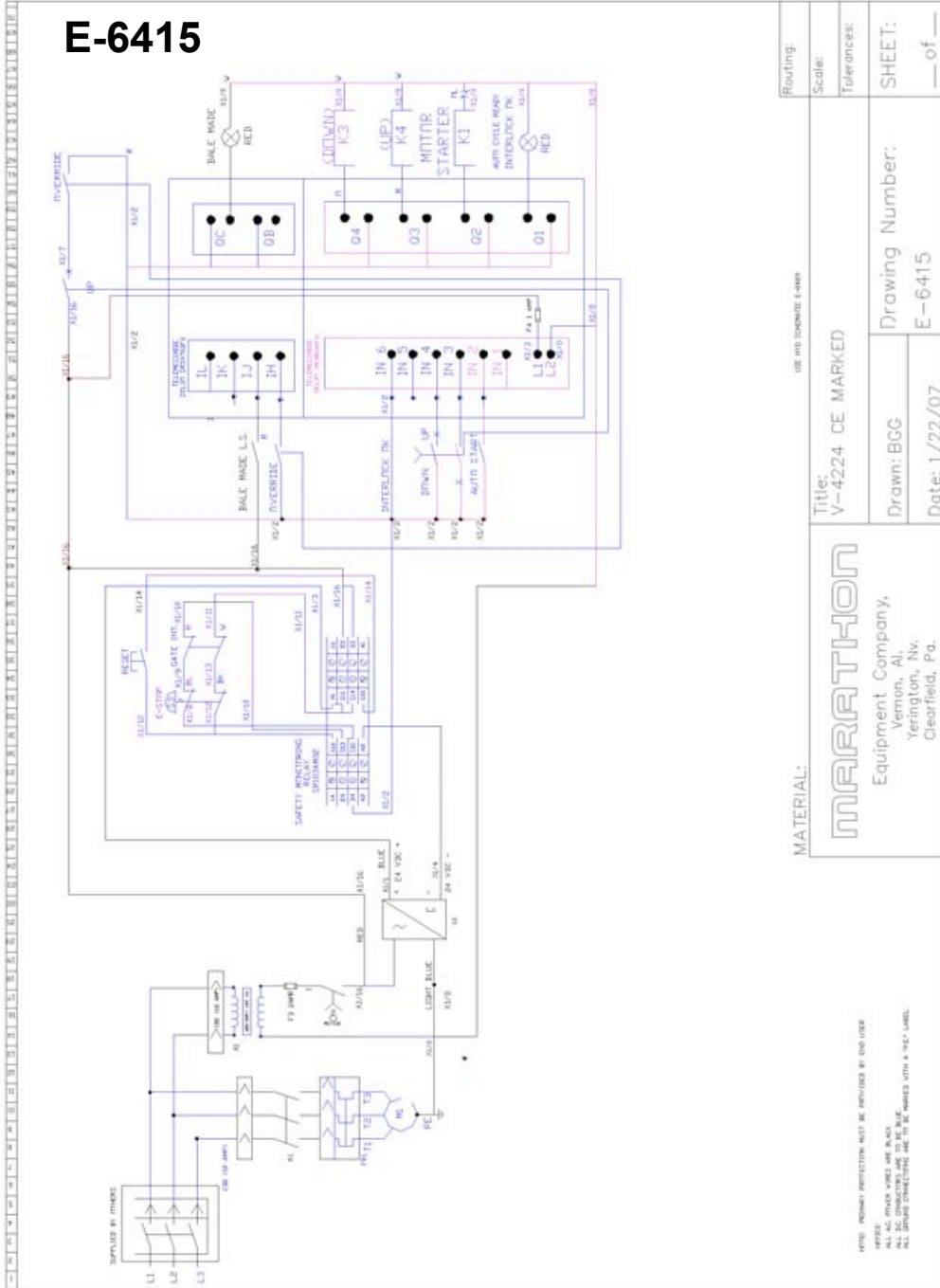

MATERIAL:		Title: V-4224 CE MARKED		Routing:
MARATHON		Drawn: BGG		Scale:
Equipment Company, Vernon, Al. Yerington, Nv. Clearfield, Pa.		Date: 1/22/07		Tolerances:
		Drawing Number: E-6415		SHEET: ___ of ___

WOTO PRIMARY PROTECTORS MUST BE SPECIFIED BY END USER
 WOTO
 ALL WOTO PIVOT VIBES ARE BLACK
 ALL DC INDICATORS ARE 24 VDC
 ALL WOTO INDICATORS ARE TO BE MARKED WITH A "W" LABEL

HYDRAULIC SCHEMATIC

E-0489

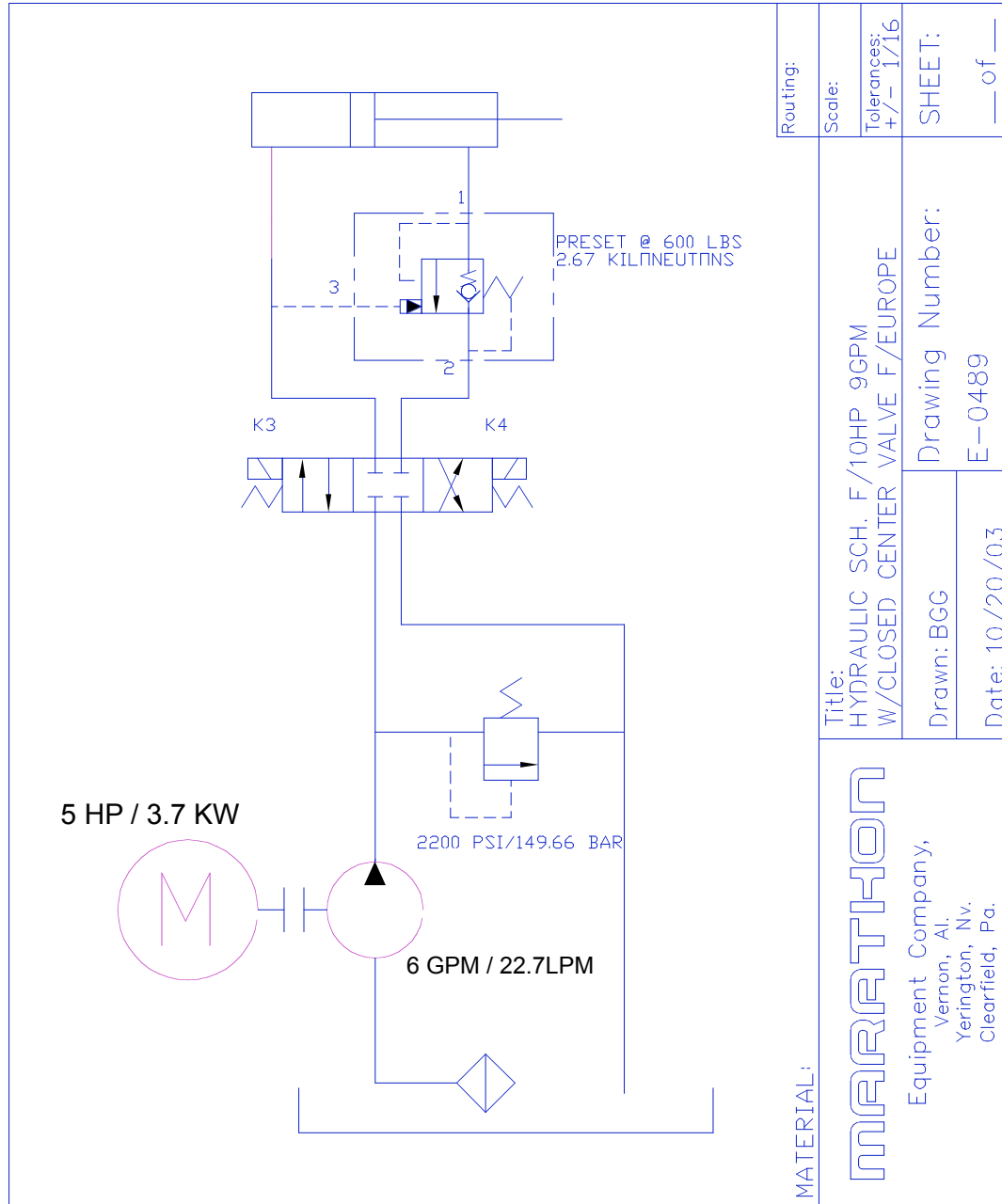

2 MAINTENANCE

PARTS LIST

PART #	DESCRIPTION	PART #	DESCRIPTION
02-0050	SUCTION FILTER	03-4585	MAGNETIC SWITCH
02-0197	BREATHER	03-0013	PRESSURE SWITCH
02-0198	SIGHT GAUGE	03-4832	MOTOR STARTER
02-0219	CLEAN OUT COVER	03-0928	PUSHBUTTON SWITCH (BLACK)
02-0628	DIRECTIONAL CONTROL VALVE	03-0939	EMERGENCY STOP SWITCH
02-3902	COUNTER BALANCE VALVE	03-0934	KEY SWITCH
02-4037	PUMP/MOTOR ADAPTER	03-0936	CONTACT BLOCK N/O
02-4207	SUBPLATE	03-0937	CONTACT BLOCK N/C
02-0242	HUB COUPLING	03-0987	PUSHBUTTON SWITCH (GREEN)
99-7778	PUMP	03-5165	MOTOR, 5 HP, 3 PHASE
02-4018	RELIEF VALVE	04-3134	CYLINDER, 3B 1.5R 25S
03-0010	LIMIT SWITCH ARM	05-0277	SPRING
03-0012	LIMIT SWITCH	05-0283	CHAIN, 2040 RIVIT
03-4152	RELAY SAFETY MONITORING	05-0285	SPROCKET F/GATE
03-4730	PLC EXPANSION 4 IN 2 OUT	05-0664	CHAIN MASTER LINK
03-4729	PLC 6 IN 4 OUT	05-2384	TURNBUCKLE W/200mm WHEEL
03-5013	MOTOR STARTER OVERLOAD	06-1409	CASTER
03-0335	RED OMNIGLOW LIGHT		
03-0351	TIMER RETAINING CLIP		

RECOMMENDED OILS

1. Union - Unax-46, Unax-AW46
2. Gulf - Harmony 47, Harmony 48-AW
3. Exxon - Teresstic 46, Nuto 46
4. Texaco - Rando 46
5. Chevron - AW 46
6. Shell -Turbo 46, Tellus 46
7. Quaker State - Dextron II (ATF)
8. Citgo - Pacemaker 46, Tellus - AW46
9. Amoco - (Rycon)

WARRANTY AND SERVICE ON MOTORS

If the baler motor fails under warranty, have it checked by a qualified electrician or service person. If there is no problem with fuses or wiring, the motor should be taken to the nearest authorized motor warranty shop. If you do not have a list of qualified shops, contact Marathon Equipment Co. The motor warranty shop will be able to inspect the motor and determine if it is factory defective. If the motor failed due to defects in material or workmanship, contact the factory to determine if the motor will be replaced or repaired. If motor failure was not due to defective material or workmanship, it will be repaired only if customer agrees to pay for expenses. Marathon Equipment Co. will not absorb cost for pickup and delivery to service centers. Removal and reinstallation are covered in the standard warranty policy.

3 INSTALLATION

GENERAL INSTALLATION

CAUTION:

Review this manual before beginning the installation. Study the jobsite and installation requirements carefully to be certain all necessary safeguards and/or safety devices are provided to protect all personnel and equipment during the installation and as a completed system.

These instructions are not intended as a substitute for training and experience in proper use, safety procedures, maintenance, or installation of this equipment.

This baler is designed for INDOOR USE ONLY.

Marathon does not assume responsibility for the installation procedures of this equipment. Conformance to applicable local, state, and federal laws concerning installation rests with the customer.

DECALS

Installation of the baler is not complete until an inspection of the warning decals has been made. Decals should be clearly visible, legible, securely applied, and in the proper location. For decal description and location, see DECALS and DECAL PLACEMENT in Section 1, pages 10 & 11.

DANGER: DO NOT CLIMB ON SIDES OF BALER. USE A LADDER OR WORK PLATFORM WHEN WORKING ON TOP OF THE BALER OR OTHER AREAS OF THE BALER THAT CAN NOT BE REACHED FROM GROUND LEVEL.

WARNING: PARTS OF THE FEED GATE WILL EXTEND ABOVE THE TOP OF THE BALER WHEN THE FEED GATE IS FULLY RAISED.

3 INSTALLATION

ANCHORING TO CONCRETE PAD

The concrete pad should be level, and a minimum of 3000 PSI concrete, steel reinforced, 150mm thick. Anchor baler to floor using anchor brackets on sides of baler base. Two 18mm diameter anchor bolts required, Red Head type recommended.

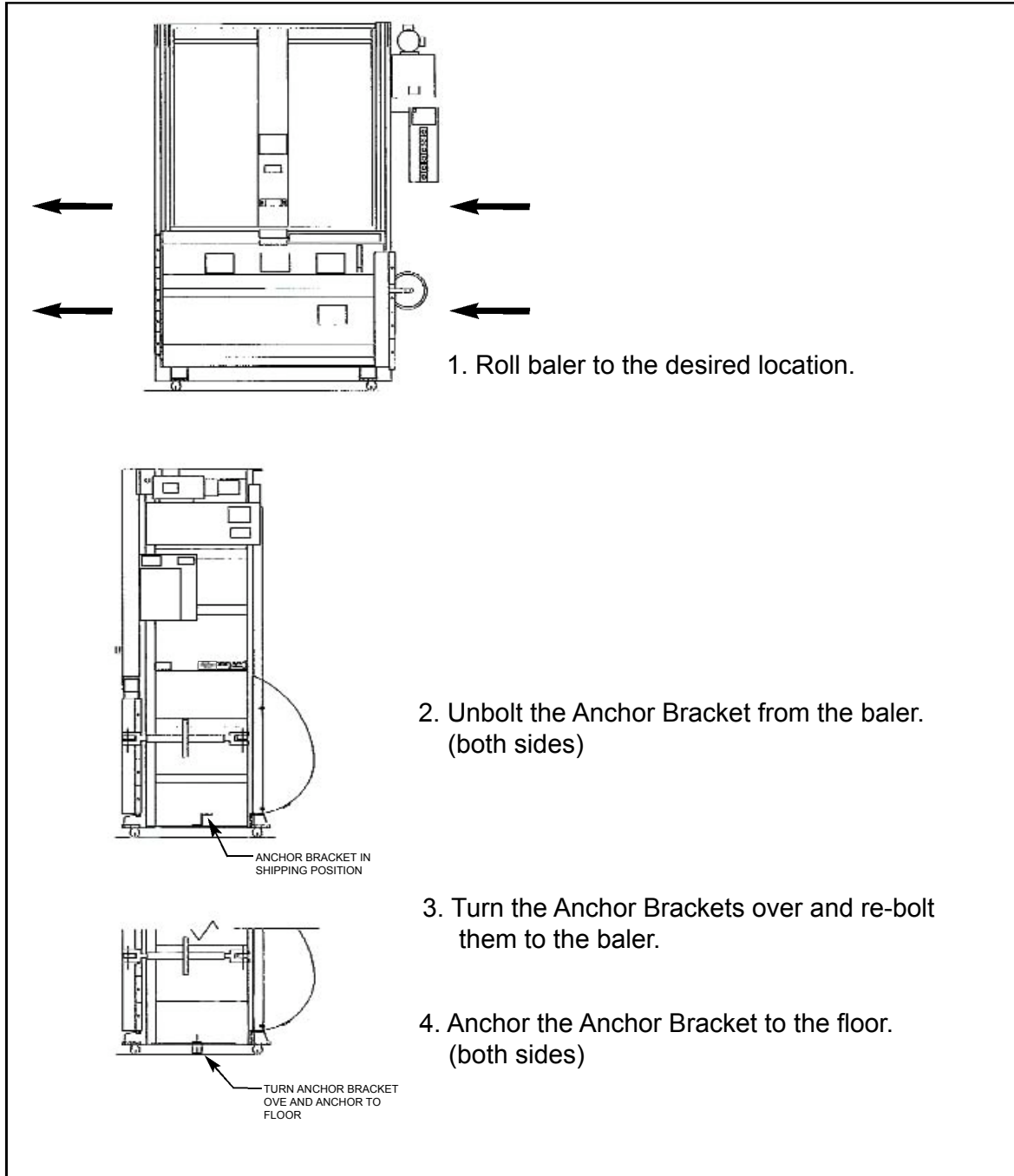

ELECTRICAL INSTALLATION

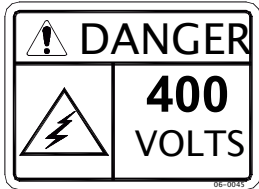

The panel box contains high voltage components. Only authorized service personnel should be allowed inside. See Lock-Out & Tag-Out instructions in the Maintenance section.

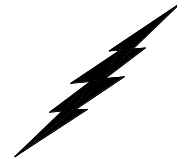

WARNING: BEFORE MAKING ANY ELECTRICAL CONNECTION, BE SURE THAT THE MAIN DISCONNECT SWITCH HAS BEEN LOCKED-OUT AND TAGGED-OUT PER THE LOCK-OUT AND TAG-OUT INSTRUCTIONS ON PAGE 2-1.

1. **BRANCH CIRCUIT PROTECTION IS NOT PROVIDED WITH THIS UNIT, AND MUST BE PROVIDED BY THE INSTALLER.** This disconnect switch must be fused, lockable, and within sight of, and not to exceed 17m from the baler, per the National Electrical Code. Additional local codes may apply. Use the FUSE AND CIRCUIT BREAKER chart and the WIRE SIZE chart in the MAINTENANCE section of this manual for reference during the electrical installation.
2. Before connecting power to the baler, check the incoming line voltage with a voltmeter. Also, check voltage wiring in the baler panel box. If the baler is not wired to the proper voltage, make necessary corrections before proceeding.
3. A lockable disconnect switch **IS NOT PROVIDED** in the panel box. Incoming power should be connected to the top of the terminal block. Be careful not to let incoming wires touch each other. A properly sized equipment ground wire should be connected to the enclosure ground lug.

DANGER: All equipment should be grounded per National Electric Code.

GROUNDING INSTRUCTIONS

This appliance must be connected to a grounded, metal, permanent wiring system; or an equipment grounding conductor must be run with the circuit conductors and connected to the equipment grounding terminal or lead on the appliance.

If there is any doubt whether the equipment is properly grounded, a qualified electrician should be consulted.

3 INSTALLATION

START-UP INSTRUCTIONS

WARNING: BEFORE START-UP, REPLACE THE 3/4" PLUG ON THE TOP OF THE POWER UNIT RESERVOIR WITH THE FILLER BREATHER CAP. THIS CAP IS SHIPPED INSIDE OF THE PANEL BOX.

DANGER: DO NOT CLIMB ON SIDES OF BALER. USE A LADDER OR WORK PLATFORM WHEN WORKING ON TOP OF THE BALER OR OTHER AREAS OF THE BALER THAT CAN NOT BE REACHED FROM GROUND LEVEL.

WARNING: PARTS OF THE FEED GATE WILL EXTEND ABOVE THE TOP OF THE BALER WHEN THE FEED GATE IS FULLY RAISED.

CAUTION: MAKE SURE PERSONS AND MATERIAL ARE CLEAR OF CHARGE BOX AREA.

1. After the electrical connections are complete, check motor rotation by the following:
 - MOTOR ROTATION APPLIES TO THREE PHASE UNITS ONLY.**
 - a. Close bale chamber door and feed gate.
 - b. Turn disconnect switch to the ON position.
 - c. Have someone turn ON the keyswitch and depress the AUTO-CYCLE button for one second and then immediately depress the EMERGENCY STOP button. Check motor rotation by watching the hub coupling through the slot in the pump-to-motor adapter. There is a rotation decal on the power unit showing correct rotation. In the event that this decal is missing, look at the hub coupling from the motor end. Rotation should be clockwise.

CAUTION: If the pump rotates backward, STOP IMMEDIATELY!
The pump will be damaged if it is operated in reverse even for short periods. Reversing any two incoming power lines will change the motor/pump rotation.
2. With the platen fully raised, check to be sure the oil reservoir is filled to the 3/4 level on the sight gauge (Refer to page 2-14 for hydraulic oil recommendations). The hydraulic system pressure has been factory set.
3. The baler is equipped with an electrical interlock which prevents the use of the AUTOCYCLE and MANUAL DOWN functions when the feed gate is in the up position. If either of these buttons start the baler when the feed gate is up, discontinue use of the baler until repairs have been made.
4. **MAKE SURE THAT THE OPERATORS ARE TRAINED IN THE PROPER USE OF THIS EQUIPMENT.**

Free Manuals Download Website

<http://myh66.com>

<http://usermanuals.us>

<http://www.somanuals.com>

<http://www.4manuals.cc>

<http://www.manual-lib.com>

<http://www.404manual.com>

<http://www.luxmanual.com>

<http://aubethermostatmanual.com>

Golf course search by state

<http://golfingnear.com>

Email search by domain

<http://emailbydomain.com>

Auto manuals search

<http://auto.somanuals.com>

TV manuals search

<http://tv.somanuals.com>