



## OWNER'S MANUAL

*Featuring...*

Important information regarding the installation, startup, operation, maintenance and ultimate enjoyment of your Marquis spa.

 **MARQUIS SPAS®**  
RELAXING YOUR WORLD



# OWNER'S MANUAL

## **WELCOME TO THE SPA LIFE!**

---

Please enjoy your new Marquis spa, but think "Safety First". Read your Owner's Manual in its entirety before installing your spa and encourage all spa users to do the same. More than just common sense, this Owner's Manual provides vital safety and operational information. Specific information regarding your particular spa can be found in the Series Manual.

We sincerely hope your spa life is a pleasant experience. If problems should arise, contact your Marquis retailer. Or contact Marquis Corp. at any of the following:

**Voice: (503)838-0888, (800)275-0888**

**Email: [service@marquiscorp.com](mailto:service@marquiscorp.com)**

**Web: [www.marquisspas.com](http://www.marquisspas.com)**

**Marquis Corp.**

**596 Hoffman Road**

**Independence, OR 97351**

*Welcome!*



# OWNER'S MANUAL

## SERIAL NUMBER LOCATION

The spa's serial number is engraved directly above the filter canister area on your spa. You will also find the serial number on the Underwriters Laboratories tag in the equipment area.

## PLEASE FILL OUT AND KEEP FOR FUTURE REFERENCE

Name of Purchaser		Date of Purchase
Address		
City	State	Zip Code
Signature		Telephone
Spa Model / Series / Color	Spa Serial #	Pack Serial #
Retailer's Name		
Retailer's Address		Telephone
City	State	Zip Code

Every effort has been made to ensure the accuracy of this manual. However, Marquis Spas reserves the right to improve its product without notice. This could create a minor variation between this manual and the actual product you receive. We apologize for any inconvenience this may cause.



# OWNER'S MANUAL INDEX

## **IMPORTANT SAFETY INSTRUCTIONS**

	<b>page(s)</b>
120V, Cord & Plug Connected Models	4
240V, Permanently Installed or Converted Models	5
All Spa Models	5-6
Safety Sign	7
Personal Safety	7
Safety Do's and Don'ts	8

## **SPA INSTALLATION**

Location	9
Shut Off Valves	10
Overheating	10
Filter Cartridge	10
Suction Fittings	10
Electrical Requirements	11
240 Volt	11
120 Volt and Converting`	11

## **STARTING YOUR SPA**

Start-up Procedure	12
All Models	12
Water Chemistry Guidelines	13

## **OPERATING YOUR SPA**

Therapy Pump(s)	14
Safety Energy Cover	14
Maximum Therapy Jetting System	15

## **SPA MAINTENANCE**

Cleaning Your Spa Exterior	16
Draining and Refilling Your Spa	16
Cleaning Your Spa and Safety Energy Cover	17
Removing the Filter and Reinstalling the Filter	17
Light Bulb Replacement	18
Winterizing Your Spa	18
Spa Maintenance Schedule & Record	19-20

## **TROUBLESHOOTING**

Equipment	21
Spa Water Maintenance	22-23

## **SPA SERIES MANUALS**

Information	24
-------------	----



# SAFETY INSTRUCTIONS

The following instructions are required to be printed by Underwriters Laboratories (UL) as a condition of the listing of this product. They contain important safety information, and we strongly encourage you to read and apply them.

## IMPORTANT SAFETY INSTRUCTIONS

**WHEN INSTALLING AND USING THIS ELECTRICAL EQUIPMENT, BASIC SAFETY PRECAUTIONS SHOULD ALWAYS BE FOLLOWED, INCLUDING THE FOLLOWING:**

- 1. READ AND FOLLOW ALL INSTRUCTIONS**
- 2. WARNING:** To reduce the risk of injury, do not permit children to use this product unless closely supervised at all times.
- 3. DANGER: RISK OF CHILD DROWNING.** Extreme caution must be exercised to prevent unauthorized access by children. To avoid accidents, ensure that children cannot use the spa or hot tub unless they are supervised at all times.

### **120 VOLT, CORD AND PLUG CONNECTED MODELS**

- 4. DANGER: RISK OF INJURY.** Connect only to a grounded source.
5. Do not bury the power cord.
- 6. WARNING:** To reduce the risk of electric shock, replace a damaged cord immediately.
7. A ground terminal (pressure wire connector) is provided on the surface of the control box inside the equipment compartment. This connector should be bonded with a minimum No. 8 AWG (8.4mm<sup>2</sup>) solid copper wire between this unit and any metal ladders, metal water pipes, metal enclosures of electrical equipment, conduit or metal equipment within five feet (1.5m) of the spa. If the spa is located on a reinforced concrete pad, the reinforced steel should also be bonded to the ground terminal.
- 8. WARNING:** Your spa is equipped with a ground fault circuit interrupter (GFCI) on the end of the power supply cord. Before each use of the spa, with the plug connected to the power supply and the unit operating, press the "test" button. The unit should stop operating and the GFCI power indicator will go out. Wait thirty seconds and then reset the GFCI by pressing the "Reset" button. The GFCI power indicator will turn on, restoring power to the spa. If the interrupter does not perform in this manner, it is an indication of an electrical malfunction and the possibility of an electric shock. Disconnect the plug from the receptacle until the fault has been identified and corrected.  
**NOTE:** Failure to wait thirty seconds before resetting the GFCI may cause the spas' power indicator on the control panel to blink. If this occurs, repeat the GFCI test procedure.



# SAFETY INSTRUCTIONS

(CONTINUED)

## 240 VOLT, PERMANENTLY INSTALLED OR CONVERTED MODELS

9. A ground terminal is provided on the terminal block (TB-1, terminal 7) located inside the control box. To reduce the risk of electric shock, connect this terminal to the grounding terminal of your electrical service or supply panel with a continuous green, insulated copper wire. The wire must be equivalent in size to the circuit conductors supplying the equipment. In addition, a bonding terminal (pressure wire connector) is provided on the outside of the control box for bonding to local ground points. To reduce the risk of electric shock, this connector should be bonded with a No. 8 AWG (8.42mm<sup>2</sup>) solid copper wire to any metal ladders, water pipes, or other metal within five feet (1.5m) of the spa to comply with local requirements.
10. Your spa uses ground fault circuit interrupters in the electrical sub-panel. Before each use of the spa and with the unit operating press the Test button on each breaker. The switch should click over to the "Trip" position. Wait thirty seconds and reset each GFCI breaker by switching it completely off and then completely on. The switch should then stay on. If either of the interrupters does not perform in this manner, it is an indication of an electrical malfunction and the possibility of an electric shock. Disconnect the power until the fault has been identified and corrected.

**NOTE:** Failure to wait 30 seconds before resetting the GFCI may cause the spa's Power Indicator (on the control panel) to blink. If this occurs, repeat the GFCI test procedure.

## ALL SPA MODELS

11. Install the spa so proper drainage is provided for the compartment containing the electrical components.
12. **DANGER: RISK OF ELECTRIC SHOCK.** Install the spa at least five feet (1.5m) of metal surfaces if, in accordance with the National Electric Code ANS/NMFA70-1993, each metal surface is permanently connected to a minimum No. 8 (8.42mm<sup>2</sup>) solid copper conductor attached to the wire bonding connector on the terminal box that is provided for this purpose.)
13. **DANGER: RISK OF ELECTRIC SHOCK.** Do not permit any appliance, such as a light, telephone, radio, or television within five feet (1.5m) of the spa or hot tub.
14. **WARNING:** To reduce the risk of injury:
  - The water in the spa should never exceed 104° F (40° C). Water temperatures between 100° F (38° C) and 104° F (40° C) are considered safe for a healthy adult. Lower water temperatures are recommended for extended use (exceeding 10 minutes) and for young children.
  - Since excessive water temperatures have a high potential for causing fetal damage during the early months of pregnancy, pregnant or possibly pregnant women should limit spa water temperatures to 100° F (38° C).
  - Before entering a spa, the user should measure the water temperature with an accurate thermometer since the tolerance of temperature-regulating devices may vary as much as +/- 5° F (3° C).
  - The use of drugs, alcohol, or medication before or during spa use may lead to unconsciousness with the possibility of drowning.
  - Persons suffering from obesity or with a medical history of heart disease, low or high blood pressure, circulatory system problems or diabetes should consult a physician before using the spa.



# SAFETY INSTRUCTIONS

(CONTINUED)

- Persons using medications should consult a physician before using a spa since some medication may induce drowsiness while other medication may affect heart rate, blood pressure, and circulation.
- 15. **DANGER:** TO REDUCE THE RISK OF INJURY TO PERSONS. Do not remove the suction fittings.
- 16. **DANGER:** RISK OF INJURY: Never operate a spa if the suction fitting(s) are broken or missing. Never replace a suction fitting with one rated less than the flow rate marked on the original suction fitting. The suction fittings in the spa are sized to match the specific water flow created by the pump. Should the need arise to replace the suction fittings or the pump, be sure that the flow rates are compatible.
- 17. **DANGER:** Children are especially sensitive to hot water. At no time should children have unsupervised access to the spa. Children must not be allowed to climb onto the spa cover. All Marquis Spas are equipped with a locking cover that meets the ASTM F1346-91 Standard for Safety Covers. Always lock the child resistant locks after using the spa for your children's safety.

## 18. **SAVE THESE INSTRUCTIONS.**

**WARNING:** Children should not use spas or hot tubs without adult supervision.

**WARNING:** Do not use spas or hot tubs unless all suction guards are installed to prevent body and hair entrapment.

**WARNING:** Do not use drugs or alcohol before or during the use of a spa or hot tub to avoid unconsciousness and possible drowning.

**WARNING:** People using medications and/or having an adverse medical history should consult a physician before using a spa.

**WARNING:** The use of alcohol, drugs, and medication can greatly increase the risk of fatal hyperthermia.

**WARNING:** Before entering the spa or hot tub measure the water temperature with an accurate thermometer.

**WARNING:** Water temperature in excess of 38°C may be injurious to your health.

**WARNING:** Prolonged immersion in a spa or hot tub may be injurious to your health.

**WARNING:** People with infectious diseases should not use a spa.

**WARNING:** Pregnant or possibly pregnant women should consult a physician before using a spa or hot tub.

**WARNING:** To avoid injury, exercise care when entering and exiting the spa or hot tub.

**WARNING:** Do not use a spa or hot tub immediately following strenuous exercise.

**CAUTION:** Maintain water chemistry in accordance with manufacturer's instructions.

## **SAFETY INSTRUCTIONS FOR FRENCH SPEAKING SPA OWNERS**

**AVERTISSEMENT:** Ne pas placer d'appareil électrique (luminaire, téléphone, radio, téléviseur, etc.) moins de 1.52 m de cette cuve de relaxation.

**AVERTISSEMENT:** Ne pas laisser les enfants utiliser une cuve de relaxation sans surveillance.

**AVERTISSEMENT:** Pour éviter que les cheveux ou une partie du corps puissent



# GENERAL INFORMATION

être aspirés, ne pas utiliser une cuve de relaxation si les grilles de prise d'aspiration ne sont pas toutes en place.

**AVERTISSEMENT:** Pour éviter l'évanouissement et la noyade éventuelle, ne prendre ni drogue ni alcool avant d'utiliser une cuve de relaxation ni quand on s'y trouve.

**AVERTISSEMENT:** Les personnes qui prennent des médicaments ou ont des problèmes de santé devraient consulter un médecin avant d'utiliser une cuve de relaxation.

**AVERTISSEMENT:** La consommation d'alcool ou de drogue augmente considérablement les risques d'hyperthermie motrelle dans une cuve de relaxation.

**AVERTISSEMENT:** Avant d'utiliser une cuve de relaxation mesurer la température de l'eau l'aide d'un thermomètre précis.

**AVERTISSEMENT:** Il peut être dangereux pour la santé de se plonger dans de l'eau plus de 38°C.

**AVERTISSEMENT:** L'utilisation prolongée d'une cuve de relaxation peut être dangereuse pour la santé.

**AVERTISSEMENT:** Les personnes atteintes de maladies infectieuses ne devraient pas utiliser une cuve de relaxation.

**AVERTISSEMENT:** Les femmes enceintes, que leur grossesse soit confirmée ou non, devraient consulter un médecin avant d'utiliser une cuve de relaxation.

**AVERTISSEMENT:** Pour éviter des blessures, user de prudence en entrant dans une cuve de relaxation et en sortant.

**AVERTISSEMENT:** Ne pas utiliser une cuve de relaxation immédiatement après un exercice fatigant.

**ATTENTION:** La teneur de l'eau en matières dissoutes doit être conforme aux directives du fabricant.

## SAFETY SIGN

Each Marquis Spa is shipped with a SAFETY SIGN in the spa's Owner's Package. Underwriters Laboratories (UL) recommends this sign be permanently installed where it is visible to the users of the spa. To obtain additional Safety Signs, contact your Marquis Spas dealer and request Part #710-0789. Replacement Owner's Manuals are also available.

## PERSONAL SAFETY

Prolonged immersion in hot water can result in HYPERTHERMIA, a dangerous condition which occurs when the internal temperature of the body reaches a level above normal (98.6° F). The symptoms of hyperthermia include dizziness, fainting, drowsiness, lethargy, and a body temperature above 98.6° F. The physical effects of hyperthermia include unawareness of impending hazard, failure to perceive heat, failure to recognize the need to exit the spa, physical inability to exit the spa, fetal damage in pregnant women, and unconsciousness resulting in a danger of drowning.

**WARNING:** The use of alcohol, drugs, or medication can greatly increase the risk of fatal hyperthermia in hot tubs and spas.

Persons taking medications which induce drowsiness such as tranquilizers, antihistamines or anticoagulants should not use the spa. Pregnant women and persons with a medical history of heart disease, diabetes, or high blood pressure should consult a physician before using the spa.





# PERSONAL SAFETY DO'S AND DON'TS

## PERSONAL SAFETY DO'S:

- Be sure your spa is connected to the power supply correctly – use a licensed contractor.
- Disconnect the spa from the power supply before draining the spa or servicing the electrical components.
- Test the GFCI monthly.
- Test the water temperature with your hand before entering the spa to be sure that it's a comfortable temperature.
- Remember that wet surfaces can be very slippery. Take care when entering and exiting the spa.
- Use the safety cover when the spa is not in use, whether it is empty or full of water.
- Keep the water clean and sanitized with correct chemical care.
- Turn on the jets when adding ANY spa water chemicals into the filtration compartment.
- Clean the filter cartridge(s) monthly to remove debris and mineral buildup which may affect the performance of the hydro therapy jets, limit the flow, or trip the high limit thermostat which will turn off the entire spa.

## PERSONAL SAFETY DON'TS:

- Don't use the spa with the equipment compartment door removed.
- Don't use the spa for long periods of time at water temperatures in excess of 102° F.
- Don't allow the jet pump(s) to operate for an extended period of time with the cover in place. Extended pump operation will cause a slow heat buildup due to water friction. The spa equipment controls are equipped with a built-in safety timer that will automatically shut off the jet pump(s) after 15 minutes of continuous operation should it have been left on inadvertently.
- Don't operate the spa at any time with the filter cartridges removed.
- Don't lift or drag the cover by using the tie-down straps; always lift and carry by using the handles.
- Don't store chemicals in the spa's equipment compartment.
- Don't hesitate to call your Marquis Spas representative with any questions or maintenance concerns.



# INSTALLATION INSTRUCTIONS

## LOCATION

For your portable spa to function properly and safely, it must be located on a hard, flat, level surface. In-ground spas require special installation techniques and should be planned in conjunction with your spa dealer. Improper installation can result in structural damage to the spa and the voiding of your spa warranty. Items to discuss with your dealer include: Local construction codes, electrical service requirements, serviceability of equipment, present underground obstructions such as gas, water and telephone lines, safety measures such as fences, locks and visibility of the spa installation from the home, street and neighbors.

- You must allow for sufficient water drainage around the spa to help preserve the equipment and support structure.
- A filled spa can weigh a great deal and the location should support the weight of the filled spa.
- Locate the equipment compartment where it will be accessible. Your spa **MUST** be installed to permit access for servicing the equipment above and/or below any decks or floors. Access is essential and must allow adequate room for service.
- Leave access to the Circuit breakers in the subpanel (240V models) or to the interrupter switch (GFCI, 120V models) on the end of the power cord.
- Be sure the spa is level and in the final position **BEFORE** filling with water. Check for power cords, tools, and hoses that may be caught underneath the spa.
- **IMPORTANT:** DO NOT LET AN EMPTY SPA REMAIN EXPOSED TO DIRECT SUNLIGHT FOR MORE THAN A FEW MINUTES. Spa surface temperatures can reach in excess of 150° F (65°C) if left exposed to the sun. Significant damage can occur if this is allowed to happen, including warping and blistering of the surface. Damage, which may occur as a result of this exposure, is not covered under the warranty.
- **CAUTION:** Never try to move a spa that has not been fully drained. To do so could result in damage to the spa and physical injury to the mover.

## OUTDOOR AND PATIO INSTALLATION

To install the spa outdoors, we recommend a reinforced concrete pad at least four inches thick. The reinforcing material should be attached to a #10 AWG bonding wire per national and local electrical code.

If you place the spa on the ground, even temporarily, place concrete pavers under the entire bottom of the spa. The concrete pavers should be at least two inches thick and level across the entire surface. The spa will inevitably settle and become unlevel on this surface, thus it's important to get it onto a solid foundation as soon as possible.

## DECK INSTALLATION

Be sure the deck can support the weight of your filled spa by checking the deck's maximum load capacity. Consult a qualified building contractor or structural engineer.

## INDOOR INSTALLATION

There are special requirements if you place your spa indoors. Flooring material must provide a good grip when wet. Proper drainage is essential to prevent water puddling. Humidity will increase and it's best to provide proper ventilation to the area and the addition of a ventilation system may be necessary.



# INSTALLATION INSTRUCTIONS

(CONTINUED)

## SHUT-OFF VALVES

Your spa is equipped with shut-off valves (see equipment diagram in the Series Manual) that shut off the water flow to the equipment system for dealer service. At times, a new spa or one that has recently been serviced, may have the shut-off valves partially closed which can restrict the water flow and hinder jet performance. Be sure the valves are fully open. ►



## FREEZE PROTECTION

When a freeze condition is detected (which occurs when the temperature in the heater housing drops to 55° F) the jet pump(s) is automatically activated. In areas with extreme cold winter conditions, your spa should be fine as long as it is left running at normal operating temperatures, or see your dealer for an optional freeze sensor. If you plan to turn the spa off, follow the instructions in this manual for winterizing your spa.

## OVERHEATING

In the case of extended hot weather, the spa water temperature may reach and maintain 104° F to 106° F. This is due to the ambient temperature and the full insulation in the spa cabinet. The simplest solution to this heat buildup is, lifting the spa cover a few inches for several hours to allow the heat to escape. You may also have the option of shortening the pump-run time. See Control panel section in the Series Manual for available options.

## FILTER CARTRIDGE

Your portable spa is equipped with the Constant Clean™ Filtration system. All Marquis Spas use #5040, 50 sq. ft. T-Handle Filter cartridge. Depending on your spa model, it will feature one or two Vortex filter(s) that includes Hi-Flo Vortex skimmer(s) and filament filter cartridge(s).

**NOTE:** It is very important that the components of these filtration systems be installed properly in the proper part of the spa (see jetting diagram and REMOVING THE FILTER for complete instructions).

## SUCTION FITTINGS

There are suction fittings in the footwell of your spa. These are openings through which the jet-pumps draw water. They have been equipped with safety covers. Suction through the fittings can be strong. The safety covers must remain in place and undamaged. A fitting with a damaged cover can be dangerous, especially to small children or people with long hair. Should any part of the body become drawn to a fitting, turn the jet-pump off immediately. Long hair should be restrained in a bathing cap, never allow it to float freely in the spa. Replace any missing or damaged suction covering. ►





# INSTALLATION INSTRUCTIONS

(CONTINUED)

## ELECTRICAL REQUIREMENTS

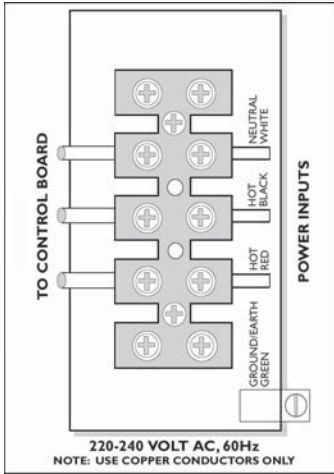

It is the responsibility of the spa owner to ensure that all electrical connections are made in accordance with all electric codes in effect at the time of installation.

### 240 Volt:

All connections must be made in accordance with the wiring diagram found on the inside of the control box cover. Connections should be made with copper conductors only – aluminum wiring should not be used with this system. All conductors, circuit breakers, and/or fuses must be sized in accordance to the Total Amperage Load as specified:

- Permanently connected
- Rated 240V, 60Hz, 50A, three wires plus ground (6 AWG copper)
- Fuse or circuit breaker size: 50 amp

This equipment is designed to operate on 60Hz Alternating Current only at a voltage of 240. Units to be operated at 240V must have all connections made by a qualified electrician in accordance with any electric codes in effect at the time of installation. All 240V units require a three wire plus ground (line 1, line 2, neutral, ground). Refer to the label at the terminal block.

A pressure wire connector is located on the exterior of the control box. If the installation includes a common bonding grid (reinforced concrete slab, ground plate beneath the spa, or any metal water pipe connection), this pressure wire connector should be bonded, with at least #8 AWG (8.42mm<sup>2</sup>, #6 in Canada) copper wire, to any metal ladder, water pipe, or other metal, within five feet of the spa.

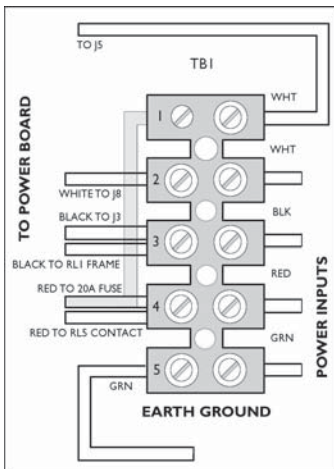

### 120 Volt:

120V units must only be connected to a properly grounded, grounding type 15 amp receptacle. 120V equipment is designed to operate on 60Hz Alternating current only at a voltage of 120, 12.5 amp. maximum load.

### To Convert 120V to 240V

All connections must be made by a licensed electrician.

1. Disconnect from power and remove cord.
2. Move red wire (TB-1) to (TB-4) as indicated by gray area.
3. Move the Heater Mode selector (J23) on the Control Board from (20A) to (50A) position. Ground Fault Circuit Interrupters (GFCI), #8145, are available from your Dealer.



# STARTING YOUR SPA

## START-UP PROCEDURE

Your spa is equipped with solid state preprogrammed Comfort Controls specific to your spa model. Please see the CONTROLS section listed under your particular spa series model.

To start your spa, you will need a spa water test kit and an underwater thermometer. It is important to follow each of these steps when starting your spa.

### Start-up procedure for all models:

1. Place spa on a hard, flat, level surface. Make sure the power supply is off.
2. Make sure that the suction fittings in the footwell are in place and undamaged.
3. Open the equipment door. On one pump models, screw the pump plug ► (supplied in packet) into the face of the pump. On multiple pump models, check to make sure the freeze line between pump one and pump two is properly connected. (See THERAPY SYSTEM in Series Manual.) Close the drain valve and screw the drain valve cap on tightly. Tighten all disconnects and open all shut-off valves. On models with a DuraBase external drain, close valve by turning outer ring clockwise. Be sure the center plug is in place and tighten.
4. Fill the spa with water to two-thirds of the way up the Vortex skimmer opening(s). ► The use of a *Fill Filter*, #5039, is recommended, especially in areas with high mineral content in the water.
5. Turn the power on and wait five seconds.
6. At this time the spa should have water flowing from the jets. If the pump has not primed and water is not flowing from the jets after two minutes **TURN OFF POWER TO THE SPA** and vent air from the pumps by slightly opening the pump union. (See TROUBLESHOOTING, Water Flow.)
7. Your spa water temperature is preset at 102° F. Use the TEMP SET pad on the bather's control panel to set the water temperature to the desired level.
8. **SHOCK** the water and test the water chemistry following the instructions in your Marquis Spa Care Water Treatment Guide, included with the spa. (Also see WATER CHEMISTRY GUIDELINES.)
9. Place the cover on the spa. It will take 12 to 24 hours for the water to heat to set temperature.
10. Check the water temperature and adjust the setting if necessary. Normal use is between 98° and 102° F.

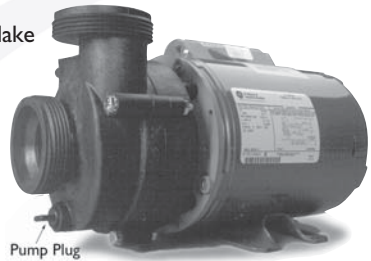



## WATER CHEMISTRY GUIDELINES

---

There are several methods available to sanitize the spa water. We recommend using chlorine or bromine in conjunction with your ozonator. No other oxidizing agents are suggested. Use of other oxidizing agents may damage equipment and void the warranty.

### **Shock Sanitation:**

After filling your spa, shock sanitize the water before using the spa. This treatment provides initial sterilization as well as kills any algae spores that may be present and oxidize undesirable minerals and organic matter in the raw water. Repeat shock treatment anytime the spa is refilled or the water has lost its chemical control due to neglect.

We recommend the use of sodium dichlorocyanurate (DyCloro) or lithium hypochlorite. Calcium hypochlorite is used for swimming pools and is not recommended for spas. Tri-Chloro is not recommended either.

It's important that you read and follow the safety tips for chemical usage and storage listed in the *Water Treatment Guide*. (Also see RECOMMENDED CHEMICAL LEVELS under TROUBLESHOOTING.)



# OPERATING YOUR SPA

## THERAPY PUMP(S)

Allow the spa to circulate on high-speed (see Spa Side Controls) for 4-5 minutes to discharge air from the plumbing system. Do not expect hot water immediately from the jets; the heater will take several hours to heat the water.

### Pr Diagnostic Message

**NOTE:** Coastal and Ultimate Series spas have a "pump priming" feature which begins at start-up. When the spa is energized, the LCD panel will display a "Pr" message. This mode will last approximately four to five minutes if not exited manually. To exit manually, press the TEMP SET pad. At this time the spa should have water flowing from the jets. If the pump has not primed and water is not flowing from the jets after two minutes,

**TURN OFF POWER TO THE SPA.** Vent air from the pumps by slightly opening the pump ► unions (see TROUBLESHOOTING section, Water Flow). After turning the power on again, the spa will initiate a new priming mode. Repeat steps above.

After you have manually exited the priming mode (or you allowed the spa to automatically exit) the LCD display will momentarily display 102° F and then the display will switch to - ° F. The system requires approximately one minute of water flow to determine the water temperature. After one minute of water flow, the temperature will be displayed as actual water temperature F. Press the TEMP SET pad to adjust the desired set temperature for the spa.

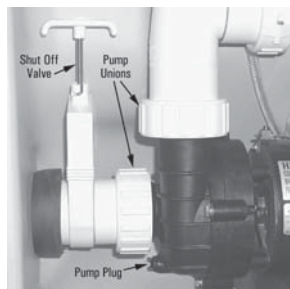

**NOTE:** Your spa has been filled and test-run at the factory. The first time your spa is filled with water, some discoloration from residual test water may appear. This will disappear when the spa is completely filled and the filtration system is functioning. Test the water for the proper chemical balance and adjust as necessary. *Marquis Spa Care™ Products* are recommended. **PROPER CHEMICAL BALANCE IS IMPORTANT.**

## SAFETY ENERGY COVER

When the spa is not in use, the Safety Energy ► Cover should be kept on the spa to retain the water's heat and to keep out dirt, leaves, etc. Your heater will maintain a constant water temperature between uses.

For your safety and convenience, the cover is equipped with adjustable straps with safety locks. Marquis suggests that you use them to help keep out unintended users and prevent covers from being blown off in windy conditions. For high wind areas, *Secure Straps* are available. Duralift cover lifts are also available to assist you in cover removal. See your Marquis Dealer.





# OPERATING YOUR SPA

(CONTINUED)

## MAXIMUM THERAPY JETTING SYSTEM

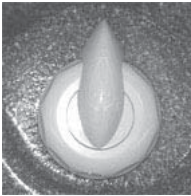

Jet Selector Valve

### JET SELECTOR VALVE

The large, gray teardrop Jet Selector lever allows you to redirect the water flow to different jet zones. (See ZONED JETTING in the Series Manual for specific options.)



Iso Boost Jet

### CASCADE NECK JETS

Your spa may be equipped with a Therapy Seat(s) featuring especially high Cascade Neck Jets. These jets are turned on and off (when the jet pump is on) using the small teardrop Neck Jet Control lever.

### ISO BOOST JET

Small directional jets are strategically located to complement the larger jets. Simply moving the nozzle redirects the water for ideal massage. The water flow can be adjusted by using the four tabs on the face of the jet to turn it.



Power Boost Jet

### POWER BOOST JET

The direction of water flow can be changed by redirecting the central nozzle. The water flow can be adjusted by using the four tabs on the face of the jet to turn it.

### POWER SWIRL JET

Large, rotating jets provide a firm, broad area of circular massage action. The water flow can be adjusted by using the four tabs on the face of the jet to turn it.



Cyclo Swirl Jet

### CYCLO BOOST JET

This large, versatile jet flows in a straight stream. The water flow can be adjusted by using the four tabs on the face of the jet to turn it.

### CYCLO SWIRL JET

This large, versatile jet can flow straight or can be made to rotate by pushing the nozzle to the side (push in the direction indicated by the point of its teardrop shape). The water flow can be adjusted by using the four tabs on the face of the jet to turn it.

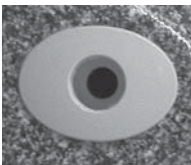

HK40 Jet

### HYDROKINETIC (HK40) JET

Unique jets are strategically positioned around the perimeter of the spa to produce a true whirlpool flow of water. This action provides a passive, whole body massage.

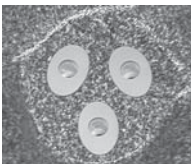

Geyser/Whirlpool Jets

### HK40 GEYSER JET

This high-flow jet is perfect for intense foot and leg massage.

### INTERCHANGEABLE JETS

Many jets are interchangeable. See your Marquis Dealer for additional jets to customize your hydrotherapy experience.





# SPA MAINTENANCE

## CLEANING THE EXTERIOR

Depending upon your choice of a natural cedar or DuraWood™ exterior, there are several routine maintenance steps you should follow.

### Wood Exterior:

The wood exterior has been treated with a water-based wood preservative at the factory. It is suggested that the exterior be treated every six months with an additional coat of preservative for maximum weather protection. Your Dealer can suggest the best preservative for your environment and also provide the *Super Deck Wood Care Kit*. ▶



### DuraWood™ Exterior:

This low maintenance exterior material is optional with the Luxury Package. Wipe down DuraWood™ exterior with a soft sponge, cloth, *Scumbag Duramitt #6875*, or *Tub Scrubber #6000* and mild, nonabrasive cleaner. Isopropyl alcohol diluted 1:1 with water may be used on stubborn marks. **DO NOT USE ACETONE** as it may damage the surface.

## DRAINING AND REFILLING THE SPA

It is recommended that you completely drain your spa every three months. A Maintenance Reminder will appear as CH to remind you to change water. More frequent draining may be required depending on use. If the water is not changed regularly, the water becomes chemically "saturated" and won't respond to regular chemical additions.

The spa should also be drained before long periods of disuse. An empty spa should be covered; direct sunlight on the spa surface can cause severe damage or blemishing and can result in the voiding of any surface warranties. The *Marquis Drain and Clean Kit #2445* includes every-thing necessary for a thorough draining regime. To drain the spa for cleaning or servicing, follow the steps below:

### Hose Bib Drain

1. Turn off the power to the spa. Use *Swirl Away Plumbing Cleaner* just prior to draining to rid the spa of any buildup from oils, lotions, etc. in the plumbing lines and jets.
2. Attach a garden hose to the hose bib in the spa's equipment area. ▶
3. Open the hose bib by turning the lever counterclockwise. Gravity will cause the water to drain from hose.
4. When the spa is empty, close the hose bib and remove the hose. Keep the hose bib open for long periods of disuse.
5. Fill your spa with fresh water from a garden hose and add the necessary chemicals. It is necessary to Shock the water after each refill before using your spa. Follow the procedures outlined in STARTING YOUR SPA.





## Dura Base™ External Drain and Fill Valve

1. Remove plug from the external Drain and Fill valve. ▼
2. Attach a hose to the external drain and fill valve on the DuraBase™. A *Fill Filter* is recommended when filling. Attach to the end of a garden hose to filter out any grit and sediment that may accumulate in the spa and potentially scratch the spa surface during the process.
3. Open the valve by turning the ring counter-clockwise. Gravity will cause the water to drain out of the hose.
4. When the spa is empty, close the valve by turning the ring clockwise and remove the hose.
5. Replace the plug in the drain and fill valve.
6. Follow step five above to refill your spa.



## CLEANING THE SPA AND SAFETY ENERGY COVER

Should the DuraShell® interior become soiled, it can be cleaned with a soft sponge, cloth *Scumbug Duramitt #6875* or *Tub Scrubber #6000*. Do not use any abrasive cleaners as they can scratch or dull the spa surface.

Your Safety Energy Cover can be cleaned with *Marquis Spa Care™ Cover Cleaner* on both top and bottom sides. *Marquis Spa Care™ Cover Cleaner* is a good quality NON-SILICONE based vinyl restorer that will help protect the surface from the sun's rays.

## REMOVING THE FILTER

Refer to the SPA MAINTENANCE SCHEDULE section for cleaning instructions. Follow these instructions when performing routine maintenance.

### Vortex Filtration:

1. Grasp the edge of the dome-shaped Vortex filter top, pull up firmly, but gently, to remove it.
2. Use the filter handle and turn the filter cartridge counterclockwise to unscrew it from its base.
3. Lift out the filter cartridge. ►



Maintenance Reminder will show CL every 30 days to remind you to clean your filter. Use *Marquis Spa Care™ Filter Revive and Filter Soak Canister*. It's recommended that you keep a spare filter on hand for cleaning. Replace your filter once a year. Filters are available through Marquis Essentials.



## REINSTALLING THE FILTER

Repeat the steps above in reverse order to reinstall the filter. Do not overtighten the filter as it may cause failure of the filter cartridge. When replacing the Vortex filter top, center the top over the raised filter ring, and press down firmly until the top snaps into place.



## LIGHT BULB REPLACEMENT

To replace a bulb for the Entryway or Underwater lighting:

1. Remove the equipment area door to find the light access.
2. Remove the lamp socket from the back of the light assembly by turning counterclockwise and pulling at the same time.
3. Gently pull the bulb out of the lamp socket and replace it with a **6 WATT BULB ONLY** from your spa retailer.
4. Install the lamp socket back into the light assembly and replace door.

Your Marquis spa is equipped with two optional underwater light colored lens covers. Your Dealer has a package of three additional lens covers which includes a replacement bulb. Optional Watercolors are available for all spas through Marquis Essentials. ▶



## WINTERIZING YOUR SPA

Your spa was designed for year-round use and many people find the combination of hot water, therapy jets, and cool winter temperatures to be especially soothing. However, if you decide to discontinue the use of your spa for any extended period of time, we suggest you follow the steps below.

**NOTE:** During long periods of inactivity, damage can occur to equipment from condensation within the equipment.

1. Turn off the power to the spa.
2. Drain the spa. (See **DRAINING AND REFILLING THE SPA.**)
3. Remove all residual water from the seating and footwell. If necessary, bail out the remaining water then dry the spa with towels. A wet/dry vacuum is recommended for best results.
4. Using the wet/dry vacuum, place nozzle over each jet nozzle to remove water from plumbing lines, starting with the highest jet and finishing with the lowest jet.

**NOTE:** If the spa is equipped with a Jet Selector valve, which is used to divert water between different jet zones, the valve must be "open" to the particular jets you are vacuuming.

5. Unscrew the pump plug(s) from the pump(s) or disconnect the freeze protection line. (See **STARTING YOUR SPA** section.)
6. Again, using the wet/dry vacuum, place nozzle over the exposed pump opening(s) to remove excess water. The pump(s) should be removed from the spa and stored in a climate-controlled room.
7. Clean the spa interior.
8. Clean the filter cartridge(s).
9. Reinstall the Safety Energy Cover and lock ▶



10. For added protection, cover the entire spa with a *Marquis Protective Spa Cover*.



# SPA MAINTENANCE SCHEDULE

## DAILY

- Replenish the water level by filling 2/3 up the Vortex skimmer opening(s). (See STARTING YOUR SPA section.)
- Check the water balance. Adjust as needed.

## WEEKLY

- Wipe down the embossed tile.
- Remove the filter cartridge(s) and rinse thoroughly with a hose and high-pressure nozzle.



## MONTHLY

- Soak the filter cartridge(s) in *Marquis Spa Care™ Filter Revive*. Rinse thoroughly in clean water. ▶
- Clean the spa Safety Energy Cover with *Marquis Spa Care™ Cover Cleaner*.

## EVERY THREE MONTHS

- Drain the spa and completely refill with water and replenish the chemicals. (See DRAINING AND REFILLING YOUR SPA.)
- Open the equipment door and check for signs of water leakage around the pump(s). Pump seals will wear out over time, especially with improper water chemistry. Early detection of pump seal failure can significantly reduce repair costs.
- While the spa is drained, the DuraShell® interior can be sponged with a spa cleaner and rinsed.

**NOTE:** Do not wax the surface as the wax will dissolve into the water, clog the filter, and reduce the effectiveness of Microban® antibacterial product protection.

## EVERY SIX MONTHS

- If your spa has a wood exterior, treat the wood with the *Super Deck Wood Care Kit*.

**NOTE:** Do not use wood sealant. Use only a high-quality, water-based wood preservative.





# TROUBLESHOOTING YOUR SPA

**PLEASE NOTE:** The following corrective actions may be performed by the spa owner. If the trouble cannot be corrected in the steps below, please refer to your spa retailer for service. (Improper servicing by an unauthorized service provider or spa owner could result in damage that will not be covered by the warranty and could cause serious injury.)

## EQUIPMENT WILL NOT OPERATE

---

- Check the control panel LCD display code.
- 240V Spas: Check the circuit breaker on the main circuit panel.
- 120V Spas: Check the GFCI power cord and reset if necessary (see IMPORTANT SAFETY INSTRUCTIONS at beginning of manual).
- Check the condition of the power cord.

## JET-PUMP(S) DOES NOT WORK

---

- Press the pump buttons on the spa side controls.
- Check plug connection at equipment pack
- Be sure the shut-off valves are completely open.
- Check for obstructions or restrictions at the suction fittings, such as leaves, etc.

## INADEQUATE JET ACTION

---

- Be sure the shut-off valves are completely open.
- Open the jets by turning the jet face to allow for maximum water flow.
- Check that the air control valve is open (rotate lever counterclockwise to open).

## LCD DISPLAY MESSAGES

---

Depending on spa models, the technology allows it to perform a number of self-diagnostic system checks and may display messages on the LCD panel. (See CONTROL section in the Series Manual.)

## NO HEAT

---

- Check temperature LCD display for desired temperature setting.

**NOTE:** Do not expect instant hot water from the jets. It will take the heater 12-24 hours to heat the spa to the temperature you desire.

- Check for obstructions or restrictions at the suction fittings.
- Inspect the filter cartridge(s) for dirt and debris.
- Check that the water is at proper level, 2/3 up the Vortex skimmer opening(s).
- Lower ambient temperatures may result in heat loss.

## LIGHT DOES NOT WORK

---

- Press the LIGHT ON/OFF pad on the spa side controls.
- Reposition the light bulb in the socket. (See REPLACING LIGHT BULB section.)
- Replace the light bulb with a **6 WATT BULB ONLY**.



# TROUBLESHOOTING YOUR SPA

(CONTINUED)

## SPA WATER MAINTENANCE

Maintaining proper water chemical balance is critical to your health and enjoyment. Marquis recommends that you use the ozonator along with the proper supplemental sanitizer.

Marquis offers a complete line of *Marquis Spa Care™* products which meet or surpass Environment Protection Agency (EPA) requirements. *Marquis Spa Care™* products are available only through authorized Marquis Dealers. For more information, refer to the *Marquis Spa Care™ Water Treatment Guide* included with your spa.



## RECOMMENDED CHEMICAL LEVELS

Failure to maintain pH level may result in irritation of the eyes, skin rashes, and other discomforts as well as damage to spa surfaces, plumbing and equipment. Chlorine levels should not exceed 3 ppm except during periods of super chlorination which is used only to treat raw water after draining the spa and after periods of heavy use.

- **Bromine:** 2 - 3 ppm
- **Chlorine:** 2 - 3 ppm
- **Alkalinity:** 80 - 150 ppm
- **pH Level:** 7.2 - 7.6

## CAUSE (C) AND SOLUTIONS (S) TO WATER MAINTENANCE

### CLOUDY WATER

- C: Inadequate filtration or dirty filter.
- S: Check that the filter is securely attached. Clean or replace filter.
- C: Water is not balanced.
- S: Shock water with *Shock Treatment* and test water with a *Water Test Strip*. Adjust sanitizer level, pH, and alkalinity levels as needed.
- C: Unfiltered particles or chemically saturated water.
- S: Use *Crystal Clear Clarifier* to combine particles; or drain the spa, clean and refill.

### CHEMICAL ODOR

- C: Too many chloramines/bromamines in the water.
- S: Shock water with *Shock Treatment* then adjust sanitizer level as necessary.

### MUSTY ODOR

- C: Not enough sanitizer in water – bacteria or algae in water.
- S: Add sanitizer as necessary and shock. Readjust sanitizer level if necessary.

### YELLOW WATER

- C: Low pH.
- S: Adjust pH with *pH and Alkalinity Increase*.

### FOAMING

- C: High concentration of body oils, lotions, or soaps as well as high temperatures and excessive contaminants.
- S: Use *Foam Eliminator* and adjust pH and sanitizer levels as needed.



## SPA WATER MAINTENANCE (CONTINUED)

### SCUM LINE IN SPA

- C: Body oils and dirt.
- S: Use *Spa Perfect* once a week to break down oils and lotions to prevent scum from forming.

### FAILURE TO GET A SANITIZER READING ON TEST STRIP

- C: Sanitizer level is too low.
- S: Add chlorine or bromine until the sanitizer tests in the recommended range.
- C: Algae present.
- S: Dirty water will consume the sanitizer as soon as it is added. Add more chlorine or bromine until the sanitizer tests and stays in the recommended range.
- C: Test strip remains white even after sanitizer has been added.
- S: Sanitizer level is extremely high. It can bleach the reagents on the test strip and give a false reading. See below.

### TOO MUCH SANITIZER IN THE WATER

- C: Too much chlorine or bromine added or dispensed into the spa.
- S: Remove Safety Energy Cover and activate high-speed jets and Air Control. Allow jets to run for 30 minutes. Test water with a *Water Test Strip* to see if desired level has been reached.

### EYE OR SKIN IRRITATION

- C: Contaminants or excessive amount of chloramines/bromamines in water.
- S: Shock water with *Shock Treatment*. Adjust sanitizer level.
- C: pH level is low.
- S: Adjust pH level as needed.

### CORROSION OF METAL

- C: Low pH level.
- S: Adjust pH level with *pH and Alkalinity Increase*.

### GREEN WATER/ALGAE

- C: Low sanitizer level or high pH.
- S: Adjust pH and sanitizer as necessary.

### ERRATIC pH TEST COLOR

- C: Sanitizer level is too high. (See TOO MUCH SANITIZER IN THE WATER)
- S: Test pH again when sanitizer level is below 5 ppm.

## MARQUIS SPA CARE™ PRODUCTS

- |                            |                             |                             |
|----------------------------|-----------------------------|-----------------------------|
| •Bromine                   | •Filter Revive              | •pH and Alkalinity Increase |
| •Calcium Hardness Increase | •Foam Eliminator            | •Shock Treatment            |
| •Chlorine Sanitizer        | •Metal and Stain Control    | •Go Brom                    |
| •Crystal Clear Clarifier   | •pH and Alkalinity Decrease |                             |





## SPA SERIES MANUALS

### **SPA SERIES MANUALS**

---

For detailed information specific to your particular spa model, please see the included or attached Series Manual. You'll find descriptions of your spa and its components, and instructions on how to operate the spa.

If you have any questions or concerns, please contact your local authorized Marquis Dealer or Marquis Corp.

*Enjoy!*



Marquis Corp.

596 Hoffman Road

Independence, OR 97351

503.838.0888 voice

800.223.6303 voice

[www.marquisspas.com](http://www.marquisspas.com)



NATIONAL  
SPA & POOL  
INSTITUTE

©Copyright Marquis Corp.  
Printed 2/2002  
MS-710-0825



LISTED BY  
UNDERWRITERS  
LABORATORIES

## Free Manuals Download Website

<http://myh66.com>

<http://usermanuals.us>

<http://www.somanuals.com>

<http://www.4manuals.cc>

<http://www.manual-lib.com>

<http://www.404manual.com>

<http://www.luxmanual.com>

<http://aubethermostatmanual.com>

Golf course search by state

<http://golfingnear.com>

Email search by domain

<http://emailbydomain.com>

Auto manuals search

<http://auto.somanuals.com>

TV manuals search

<http://tv.somanuals.com>