MASTER[®]

**USER'S MANUAL
INSTRUKCJA OBSŁUGI
РУКОВОДСТВО ПО ПРИЕМЕНИЮ**

WA 41 A

WA 59 A

**UNIVERSAL OIL HEATERS
NAGRZEWNICE NA OLEJ UNIWERSALNY
НАГРЕВАТЕЛИ НА УНИВЕРСАЛЬНОЕ
МАСЛО**

OESA

Installation must be made in accordance with local regulations which may differ from this installation manual.
Montażu należy dokonać zgodnie z lokalnymi przepisami, które mogą się odbiegać od zaleceń w poniższej instrukcji obsługi.
Сборку следует провести в согласии с местными законами, которые могут отличаться от этого руководства.

CONTENTS SPIS TREŚCI СОДЕРЖАНИЕ	PAGE STRONA СТРАНИЦА
* Description, warnings and installation Opis, ostrzeżenia i montaż Описание, предупреждения, сборка	
* Combustion chamber, ignition procedure and safeguards Komora spalania, uruchamianie i zabezpieczenia Камера сгорания, порядок запуска, предохранительные устройства	
* Maintenance, taking out of operation, and draught test indicator Konservacja, wyłączenie i tester przewodu kominowego поддержка, окончание процесса и указатель проверки тяги	
* Drawing Schemat urządzenia Схема нагревателя	
* Spare parts list Lista części zamiennych Список запасных частей	
* Faults Usuwanie usterek Устранение неисправностей	
* Technical details Dane techniczne Технические данные	
Electric wiring diagram Schemat elektryczny Электрическая схема	

ENGLISH

To obtain full benefit from the WA 41 A and trouble free operation, read the following instructions and information carefully.

DESCRIPTION AND FUNCTION

- * The control panel incorporates a switch, a locking device for the fuel and a pilot light;
- * The electric pump motor drives the fuel pump, which is positioned in the tank.
- * The fuel pump delivers fuel to the combustion dish and is controlled by means of the button above the control panel, At position low, the consumption is approx. 2,5 l/h. At position high, the consumption is approx. 4,3 l/h. One and another depends on viscosity.
- * The main fan is controlled by a thermostat. As soon as the combustion chamber has warmed up sufficiently, the fan starts to operate.
- * The burner is equipped with an air intake fan to supply air for combustion. This air combustion fan stops when the flame has extinguished. Pipes ϕ 200 mm can be connected to this fan so that the combustion air can be sucked from outside the area to be heated.
- * Most types of waste oil can be used, such as gearbox oil, gas oil, diesel oil, hydraulic oil, HBO 1, 2 and 3, but not those with a high viscosity, such as SAE90.
DO NOT USE TRANSFORMER OIL WHICH MIGHT CONTAIN SUBSTANCES DETRIMENTAL TO THE PERFORMANCE OF THE BURNER (PCB)
- * When the pump motor stops, the flame will extinguish once the fuel in the burner dish is exhausted.

WARNINGS

- 1 There could be a possible danger of explosion if the burner is reignited while it is still warm.
- 2 There must be sufficient air for combustion; make sure that the combustion air intake fan is never blocked.
- 3 Modifications made to the burner by dealer or end user, invalidate the manufacturer's warranty.

INSTALLATION

- * For installation, consult the local prescriptions.
- * The burner must be installed on a completely level, concrete floor.
- * Check that the chose position presents no problem for:
 - electrical supply 230v/2Amp.;
 - flue pipe installation;
 - combustion air supply.
- * Open the top cover of the burner and remove the cover of the combustion chamber.

- * The following items are packed within the combustion chamber:
 - 1x T-piece with built-in draught stabiliser for flue pipe connection
 - 1x cleaning shovel
 - 1x scraping tool to remove residue from combustion dish
 - 1x combustion dish
 - 2x burner ring
 - 1x spare card to seal the bottom of combustion chamber
 - 2x handle with bolts
 - 1x pedal

FLUE PIPE

- For clean and trouble free combustion, it is essential that the flue pipe is installed correctly.
- a. minimum diameter of flue pipe: 150mm
 - b. check that flue connections are well sealed
 - c. minimum flue height: 5 m
 - d. the wind must be able to reach the top of the flue from all directions (e.g.: it may be necessary to extend flue above roof apex)
 - e. all pipes should be vertical if possible, keep horizontal pipes to the absolute minimum
 - f. avoid bends in the flue installation if possible but if unavoidable e.g. if flue has two bends because of installation through a wall or window, then:
 1. the pipe should be as high as possible within the building
 2. flue pipe outside the building should be insulated (double walled)
 3. the minimum height of the flue has to be increased to 7.5 m to compensate.

use a raincap

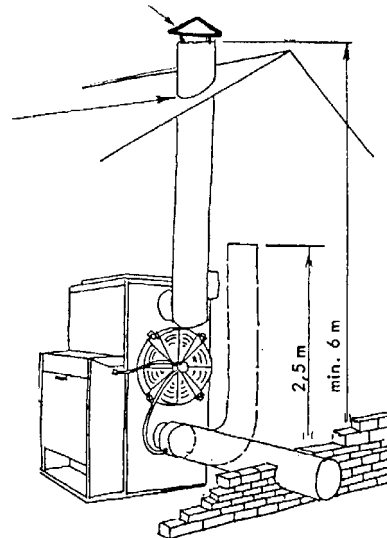

COMBUSTION CHAMBER (see figure 1)

- * Place burner ring (1) in the burner pot and replace combustion chamber cover.
- * Unlock the sliding bottom drawer (2) by means of pedal (3) and safety catch (6) and open.
- * The bottom of the combustion chamber and combustion dish are now accessible, see figure 2. Ignition and cleaning can now be dealt with easily.

IGNITION PROCEDURE

1. Fill the tank with fuel. Slide the locking button on the control panel vertically to open the tank, which hinges forward.
2. Switch to "0"; connect plug to electricity supply and switch on at socket.
3. Put capacity regulator in low position.
4. Pour approx. 1/3 litre of paraffin in the combustion dish. Crumple some paper into a ball, light it and drop into the dish to ignite the oil. Close and lock the sliding drawer. Check through the top cover that the sealing around the bottom of the combustion chamber is visible.
5. Switch to "1". After about 5 minutes the combustion chamber will be warmed up sufficiently for the main fan and pump motor to come into operation. The orange pilot light will illuminate.
6. After approx. 30 minutes, make any necessary adjustments to the draught stabiliser.
7. During initial commissioning burn, there will be some fumes from the heat resistant paint finish and because the combustion chamber has been oiled against corrosion. These fumes will cease after about 30 to 40 minutes.

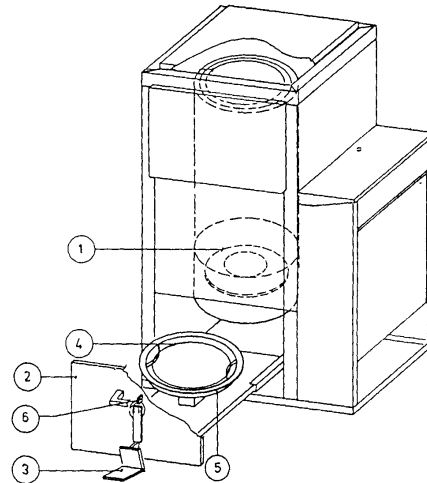

SAFEGUARDS

- * The burner is equipped with a thermostat controlling the flame. Should the flame be extinguished for any reason, this thermostat will stop the fuel pump as well as the main fan. For causes, see chapter "Location of faults".
- * An overheating thermostat which shuts off the fuel supply completely is reset by means of a push button in the burner. For causes, see chapter "Location of faults".
- * The fuel supply system is equipped with an "overflow tube", through which the oil flows back into the tank in case the pipe to the burner becomes obstructed. After the flame has extinguished, the flame control thermostat will switch off the burner. For causes, see chapter "Location of faults".
- * The burner is equipped with an "overflow security", located underneath the bottom of the combustion chamber. This will come into operation if, over a period, the fuel is not burnt completely. The excess fuel will flow from the combustion dish, via an inlet tube, into a small container. This container is positioned on a spring-loaded micro switch. As soon as this container is half full, the fuel pump is switched off automatically. For causes, see chapter "Location of faults".
- * The air combustion fan is equipped with a thermostat.

Figure 1

MAINTENANCE

The heater requires very little maintenance and the regularity of such maintenance will depend greatly on the type(s) of waste oil being burnt. The cleaner the fuel, the less maintenance is required.

In general:

- * clean combustion dish and overflow tube daily;
- * clean burner pot, burner ring and combustion chamber at least once a week. Ensure that the air intake holes of combustion chamber and lower side (3) at bottom connection are not obstructed;
- * clean heat exchanger, fuel supply pipe, tank and filter once per heating season;
- * combustion chamber bottom: as soon as the seal around the bottom of the combustion chamber is no longer visible, it is essential that it is replaced, normally this is once per heating season.
- * Clean filling sieve, fuel tank and filter regularly.
- * The water in the tank can be drained by means of a tap at the bottom of the tank.

TAKING OUT OF OPERATION

- * Switch to position "0". The fuel pump will stop and the flame will be extinguished once the oil in the combustion chamber is burnt.
- * Remove the plug from the wall socket after the air intake fan has cooled down.
- * If the burner is not to be used for a long period, combustion chamber, combustion dish, heat exchanger and tank should be cleaned carefully and protected against corrosion.

The heater is delivered with a spare seal. If this seal is not replaced at the appropriate time, leakages causing soot formation may occur. The pedal assembly is equipped with an adjusting screw (2).
If leakages occur or replacement of the seal is necessary, adjust this screw so that the bottom of the combustion chamber is set at more pressure against the chamber.

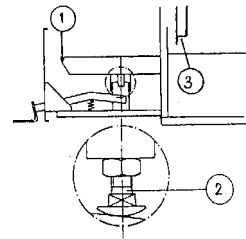
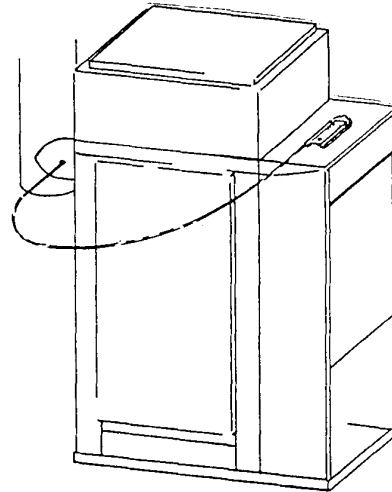

Technical Data / Dane Techniczne / Технические данные

	Jednostka	WA 41 A	WA 59 A
Capacity min. brutto *	BTU/h	82.000	123.000
Wydajność minimalna brutto	kW	24	36
Тепловая мощность мин. брутто			
Capacity max. brutto *	BTU/h	140.000	202.000
Wydajność maksymalna brutto	kW	41	59
Тепловая мощность макс. брутто			
Fuel Consumption min.	l/h	2,5	3,8
Zużycie paliwa min.			
Расход топлива мин.			
Fuel Consumption max.	l/h	4,3	6,2
Zużycie paliwa max.			
Расход топлива макс			
Burning duration with full tank min.	h		
Czas pracy na pełnym zbiorniku paliwa – wydajność min.			
Время работы с полным топливным баком – мин.мощность			
Burning duration with full tank max.	h		
Czas pracy na pełnym zbiorniku paliwa – wydajność max.			
Время работы с полным топливным баком – мин.мощность			
Heated Airflow	m ³ /h	3000	3000
Przepływ powietrza			
Нагретый воздушный поток			
Voltage	V/Hz	220-240 / 50	220-240 / 50
Zasilanie sieciowe			
Электрическое снабжение			
Power Consumption	A	1,1	1,2
Pobór mocy			
Потребляемый ток			
Flue Diameter	mm	150	200
Średnica rury kominowej			
Диаметр патрубка для отвода отработанных газов			
Width	cm	820	820
Szerokość			
Ширина			
Length	cm	880	880
Długość			
Длина			
Weight	kg	135	175
Waga			
Вес			
Height	cm	1.080	1.290
Wysokość			
Высота			

* Depending on viscosity

* W zależności od lepkości

* В зависимости от вязкости

WA 41 A

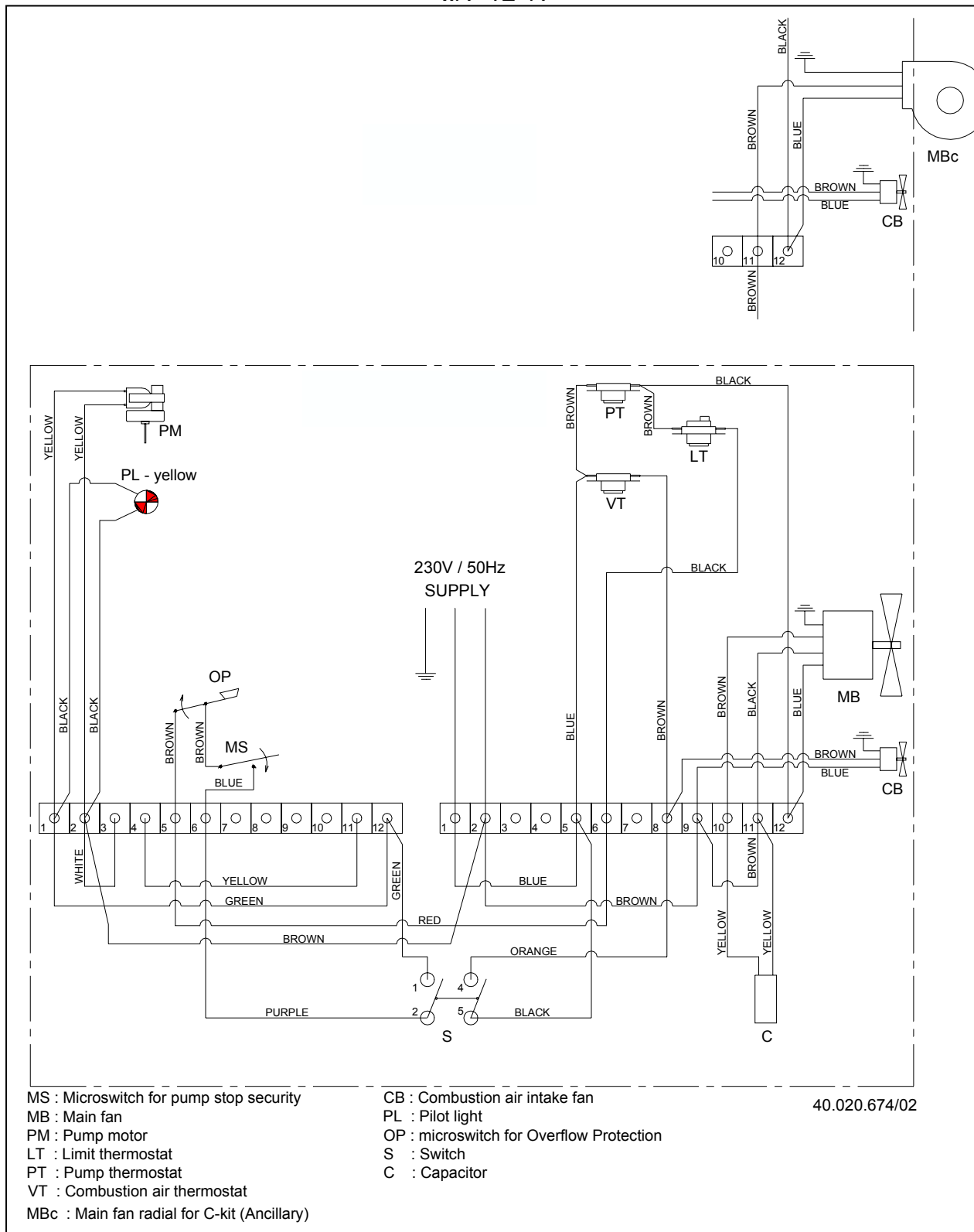

- | | |
|----|---|
| FL | Flashlight / Lamka kontrolna / Сигнальный свет |
| MS | Microswitch / Mikrowyłącznik / Микропереключатель |
| MB | Main fan / wentylator główny / Главный вентилятор |
| PM | Pump motor / silnik pompy / Двигатель насоса |
| LT | Overheating thermostat / Termostat przegrzania / Термостат перегрева |
| T | Thermostat / Termostat / Термостат |
| CB | Combustion air intake fan / wentylator komory spalania / Вентилятор камеры сгорания |
| PL | Pilot light / Lamka kontrolna / Контрольный свет |
| OS | Overflow security / zabezpieczenie przed przelewem / Защита от перелива |
| S | Switch / Przełącznik / Переключатель |
| C | Condensator / kondensator / Конденсатор |

WA 59 A

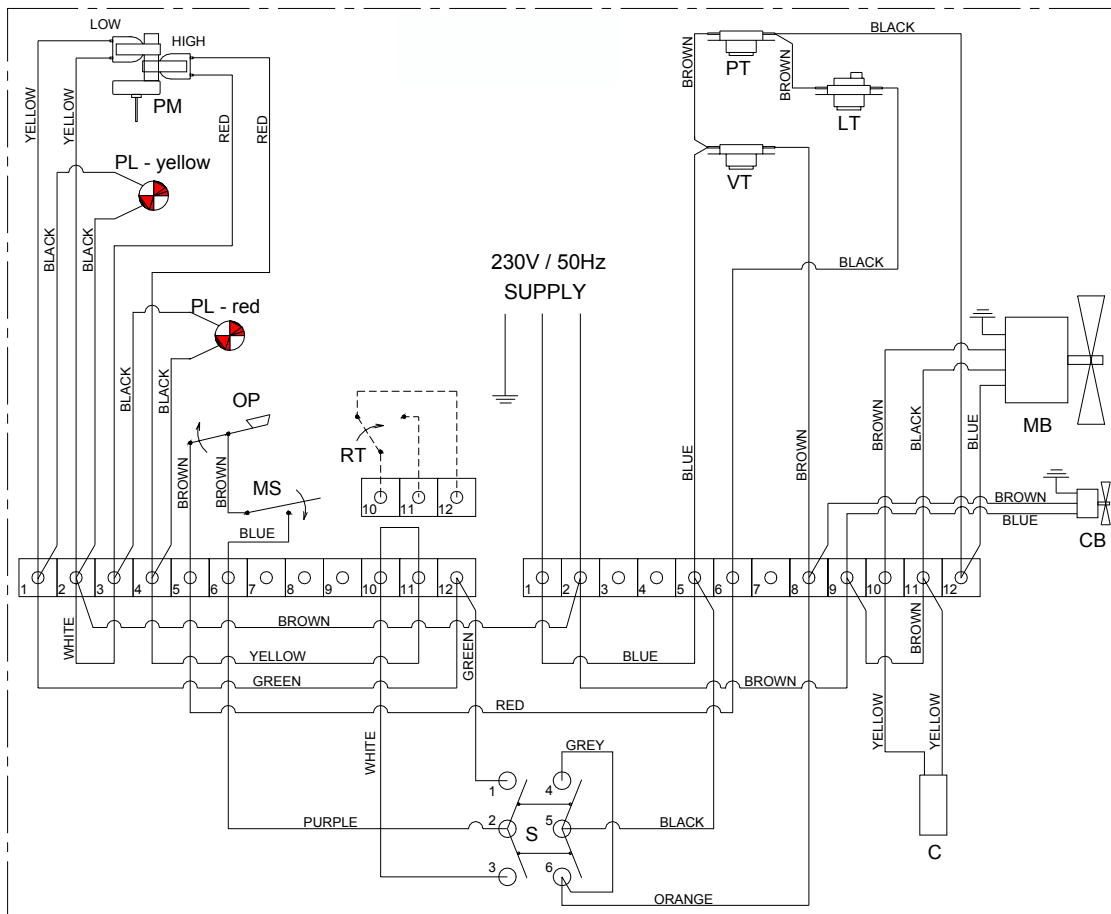
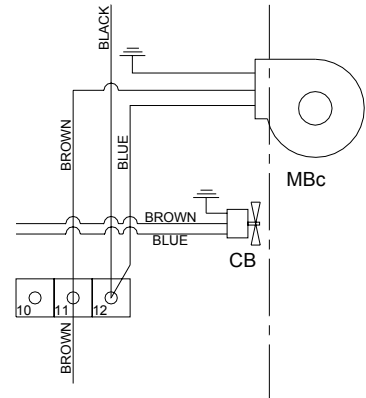

MS : Microswitch for pump stop security
 MB : Main fan
 PM : Pump motor
 LT : Limit thermostat
 PT : Pump thermostat
 VT : Combustion air thermostat

CB : Combustion air intake fan
 PL : Pilot light
 OP : microswitch for Overflow Protection
 S : Switch
 C : Capacitor

40.020.592/03

MBc : Main fan radial for C-kit (Ancillary)

RT : Room thermostat (Accessory for AT-500)

FL Flashlight / Lamka kontrolna / Сигнальный свет
 MS Microswitch / Mikrowyłącznik / Микропереключатель
 MB Main fan / wentylator główny / Главный вентилятор
 PM Pump motor / silnik pompy / Двигатель насоса
 LT Overheating thermostat / Termostat przegrzania / Термостат перегрева
 T Thermostat / Termostat / Термостат
 CB Combustion air intake fan / wentylator komory spalania / Вентилятор камеры сгорания
 PL Pilot light / Lamka kontrolna / Контрольный свет
 OS Overflow security / zabezpieczenie przed przelewem / Защита от перелива
 S Switch / Przełącznik / Переключатель
 C Condensator / kondensator / Конденсатор

WA 41 A

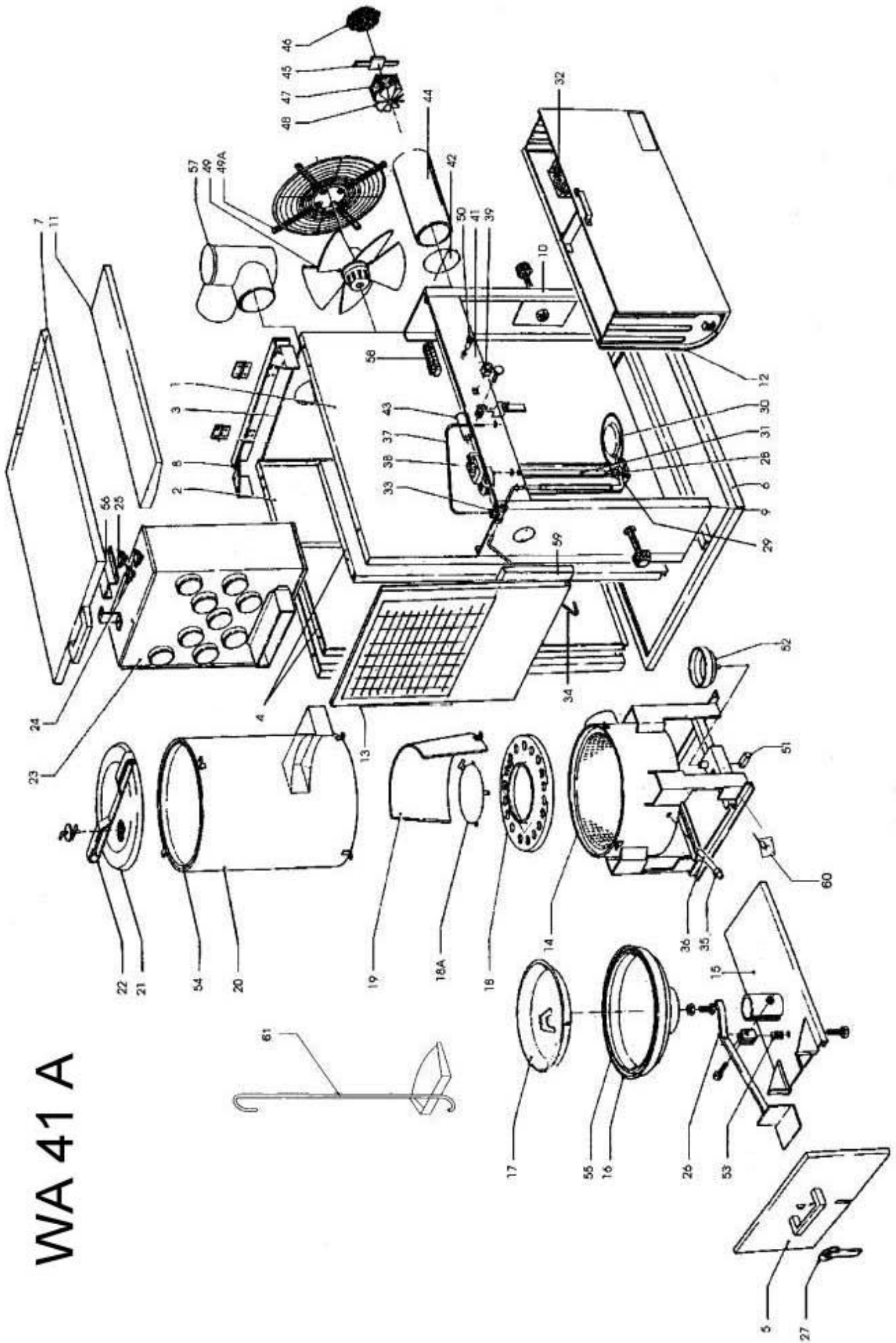

UNIVERSAL OIL HEATERS – WA 41

Pos.	Code NR	Description
1	S/R	SIDE PLATE LEFT
2	S/R	SIDE PLATE RIGHT
3	S/R	BACK PANEL
4	S/R	COOLING PLATE
5	S/R	SLIDING PANEL
6	S/R	BOTTOM PANEL
7	S/R	TOP LID
8	S/R	FRAME
9	S/R	SIDE PANEL LEFT
10	S/R	SIDE PANEL RIGHT
11	S/R	TOP LID OF CONTROL PANEL
12	4506.137	TANK
13	S/R	BLOWING GRILL
14	4506.141	VAPORIZING SECTION
15	S/R	SLIDER
16	4506.138	BOTTOM
17	4506.021	COMBUSTION DISH
18	4506.043	BURNER RING
18a	4506.044	HEAT SHIELD WA 41A
19	4506.133	BAFFLE PLATE
20	4506.136	COMBUSTION CHAMBER
21	4506.130	COVER COMBUSTION CHAMBER
22	4506.125	LOCKING BAR
23	4506.140	HEAT EXCHANGER
24	4506.019	THERMOSTAT
25	4506.020	OVERHEAT THERMOSTAT
26	4506.126	LEVER
27	S/R	LOCKING DEVICE
28	4506.006	FUEL PUMP
29	S/R	FUEL PUMP SUPPORT
30	4506.005	FILTER
31	4506.123	DRIVE SHAFT
32	4506.134	FUEL TANK FILTER
33	S/R	3-WAY CONNECTOR
34	S/R	SUPPLY PIPE
35	4506.131	CONNECTOR
36	4506.118	DRIP FEED PIPE
37	4506.122	RETURN LINE
38	4506.003	PUMP MOTOR
39	4506.121	SWITCH
40	N/A	PILOT LIGHT RED
41	S/R	CONTROL PANEL
42	S/R	AIR INLET PLATE
43	4506.119	CAPACITOR
44	S/R	FAN HOUSING
45	S/R	MOTOR CLIP
46	S/R	PROTECTION GRILL
47	4506.135	MOTOR
48	4506.116	COMBUSTION FAN
49	4506.139	MAIN FAN
49a	4506.132	PROTECTION GRILL
50	4506.117	PILOT LIGHT YELLOW
51	4506.202	MICRO SWITCH
52	4506.124	OVERFLOW TRAY
53	4506.128	COMPRESSION SPRING
54	4506.120	SEALING CORD
55	4506.129	SEALING CORD
56	S/R	THERMOSTAT BRACKET
57	4506.002	T-PIECE
58	4506.115	CROWN STRIP
59	4506.127	COOLING PLATE
60	S/R	MICRO SWITCH PUMP STOP
61	S/R	SHOWEL

S/R – Parts available by special request only

WA 59 A

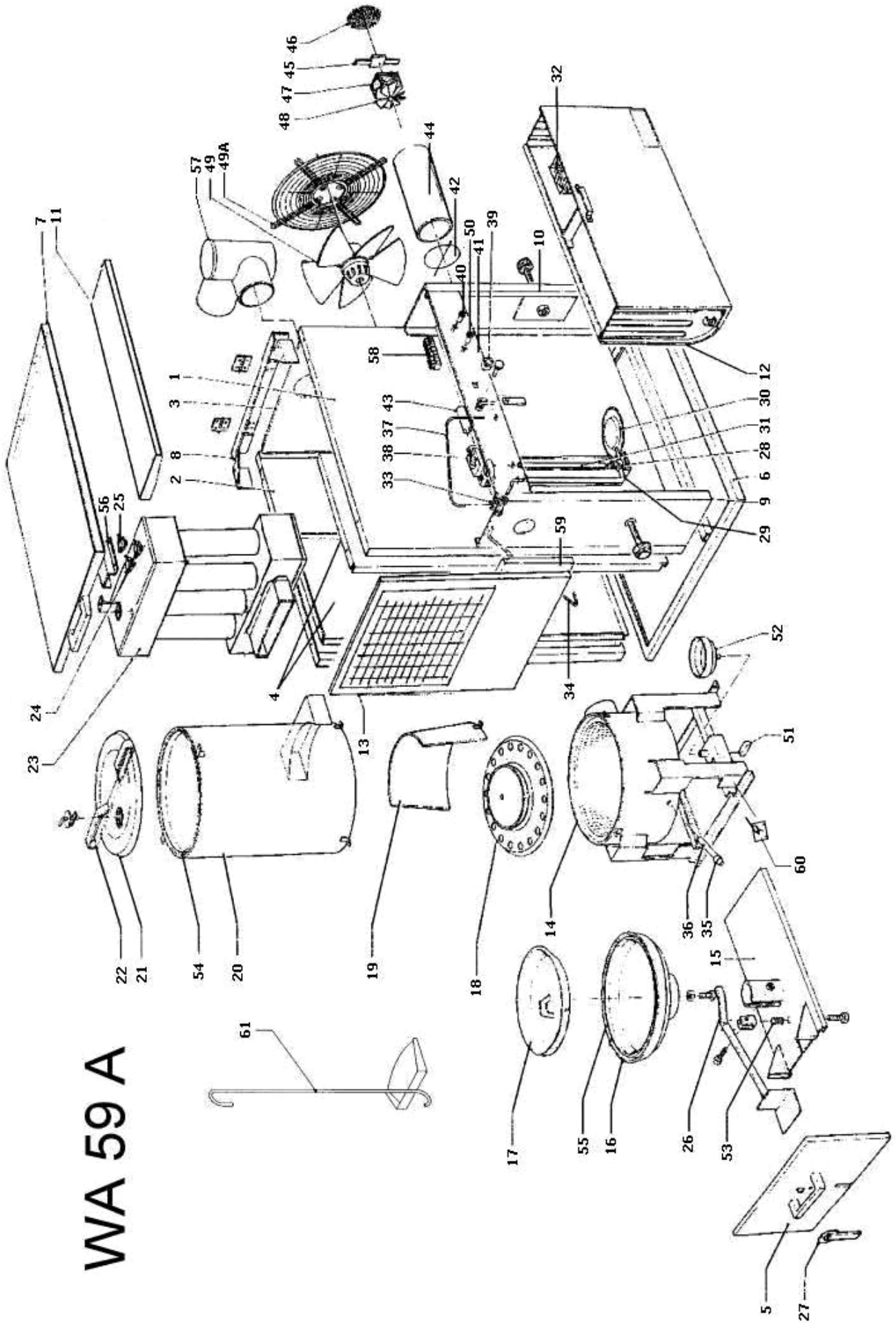

UNIVERSAL OIL HEATERS – WA 59

Pos.	Code NR	Description
1	S/R	SIDE PLATE LEFT
2	S/R	SIDE PLATE RIGHT
3	S/R	BACK PANEL
4	S/R	COOLING PLATE
5	S/R	SLIDING PANEL
6	S/R	BOTTOM PANEL
7	S/R	TOP LID
8	S/R	FRAME
9	S/R	SIDE PANEL LEFT
10	S/R	SIDE PANEL RIGHT
11	S/R	TOP LID OF CONTROL PANEL
12	4506.137	TANK
13	S/R	BLOWING GRILL
14	4506.148	VAPORIZING SECTION
15	S/R	SLIDER
16	4506.138	BOTTOM
17	4506.021	COMBUSTION DISH
18	4506.149	BURNER RING
19	4506.133	BAFFLE PLATE
20	4506.145	COMBUSTION CHAMBER
21	4506.130	COVER COMBUSTION CHAMBER
22	4506.125	LOCKING BAR
23	4506.147	HEAT EXCHANGER
24	4506.019	THERMOSTAT
25	4506.020	OVERHEAT THERMOSTAT
26	4506.126	LEVER
27	S/R	LOCKING DEVICE
28	4506.143	FUEL PUMP
29	S/R	FUEL PUMP SUPPORT
30	4506.005	FILTER
31	4506.123	DRIVE SHAFT
32	4506.134	FUEL TANK FILTER
33	S/R	3-WAY CONNECTOR
34	S/R	SUPPLY PIPE
35	4506.131	CONNECTOR
36	4506.118	DRIP FEED PIPE
37	4506.122	RETURN LINE
38	4506.004	PUMP MOTOR
39	4506.058	SWITCH
40	N/A	PILOT LIGHT RED
41	S/R	CONTROL PANEL
42	S/R	AIR INLET PLATE
43	4506.119	CAPACITOR
44	S/R	FAN HOUSING
45	S/R	MOTOR CLIP
46	S/R	PROTECTION GRILL
47	4506.135	MOTOR
48	4506.116	COMBUSTION FAN
49	4506.139	MAIN FAN
49a	4506.132	GRILL
50	4506.117	PILOT LIGHT YELLOW
51	4506.202	MICRO SWITCH
52	4506.124	OVERFLOW TRAY
53	4506.128	COMPRESION SPRING
54	4506.120	SEALING CORD
55	4506.129	SEALING CORD
56	S/R	THERMOSTAT BRACKET
57	4506.144	T-PIECE
58	4506.115	CROWN STRIP
59	4506.127	COOLING PLATE
60	S/R	MICRO SWITCH PUMP STOP
61	S/R	SHOWEL

S/R – Parts available by special request only

DECLARATION OF CONFORMITY DEKLARACJA ZGODNOŚCI

We hereby declare that the technical products :
Oświadczam się, że urządzenia :



uniwersal oil heaters :
nagrzewnice na olej uniwersalny :

WA 29 A
WA 41 A
WA 59 A

are in conformity with:
są zgodne z :

LOW VOLTAGE DIRECTIVE :

73/23/EWG

DYREKTYWĄ NISKONAPIĘCIOWĄ :

ELECTRO MAGNETIC COMPATIBILITY DIRECTIVE :

89/336/EWG

DYREKTYWĄ KOMPATYBILNOŚCI ELEKTRYMAGNETYCZNEJ :

MACHINERY DIRECTIVE :

98/37/EWG

DYREKTYWĄ MASZYNOWĄ :

Technical standards and specifications :
Dokumenty odniesienia :

EN 60335

The products are provided with
Wyroby są dostarczane z



a marking of conformity.
jako oznaczenie zgodności.

CE marking was made in 2004.

Oznakowanie CE zostało umieszczone w 2004r.

DESA POLAND Sp. z o.o.
ul. Rolna 8, Sady
62-080 TARNOWO PODGÓRNE
tel. (0-61) 654 4000, fax (0-61) 654 4001
NIP 779-20-08-988 (3)

Manufacturer's stampo
Pieczętka zakładu

DESA POLAND Sp. z o.o.

Paweł Dobroń
Dyrektor Handlowy

24 XI 2005

Date and signature of authorized person
Data i podpis osoby upoważnionej

Free Manuals Download Website

<http://myh66.com>

<http://usermanuals.us>

<http://www.somanuals.com>

<http://www.4manuals.cc>

<http://www.manual-lib.com>

<http://www.404manual.com>

<http://www.luxmanual.com>

<http://aubethermostatmanual.com>

Golf course search by state

<http://golfingnear.com>

Email search by domain

<http://emailbydomain.com>

Auto manuals search

<http://auto.somanuals.com>

TV manuals search

<http://tv.somanuals.com>