



**Maxtor D540X-4G
Product Manual**

March 5, 2002

P/N: 1620-A



© March 5, 2002 Maxtor Corporation. All rights reserved. Printed in U.S.A.

This publication could include technical inaccuracies or typographical errors. Changes are periodically made to the information herein – which will be incorporated in revised editions of the publication. Maxtor may make changes or improvements in the product(s) described in this publication at any time and without notice.

Maxtor®, MaxFax® and No Quibble Service® are registered trademarks of Maxtor Corporation, registered in the U.S.A. and other countries. Maxtor D540X-4G, AutoTransfer, AutoRead, AutoWrite, DisCache, DiskWare, Defect Free Interface, and WriteCache are trademarks of Maxtor Corporation. All other brand names or trademarks are the property of their manufacturers.

Maxtor reserves the right to make changes and improvements to its products, without incurring any obligation to incorporate such changes or improvements into units previously sold or shipped.

This product or document is protected by copyright and distributed under licences restricting its use, copying, distributing, and decompilation. No part of this product or document may be reproduced in any form by any means without prior written authorization of Maxtor and its licensors, if any.

RESTRICTED RIGHTS LEGEND: Use, duplication, or disclosure by the government is subject to restrictions as set forth in subparagraphs (c)(1)(ii) of the Rights in Technical Data and Computer Software clause at DFARS 252.227-7013 and FAR 52.227-19.

THIS PUBLICATION IS PROVIDED “AS IS” WITHOUT WARRANTY OF ANY KIND, EITHER EXPRESS OR IMPLIED, INCLUDING, BUT NOT LIMITED TO, THE IMPLIED WARRANTIES OF MERCHANTABILITY, FITNESS FOR A PARTICULAR PURPOSE, OR NON-INFRINGEMENT.

You can request Maxtor publications from your Maxtor Sales Representative or order them directly from Maxtor.

Publication Number: P/N: 1620-A

Corporate Headquarters:

510 Cottonwood Drive
Milpitas, California 95035
Tel: 408-432-1700
Fax: 408-432-4510

Research and Development Center:

2452 Clover Basin Drive
Longmont, Colorado 80503
Tel: 303-651-6000
Fax: 303-678-2165

Revision History- Manual P/N: 1620-A

REVISION	EC NO.	SECTION	DESCRIPTION	DATE
Revision-A	2004052	All	Initial Release	March 5, 2002

Before You Begin

Thank you for your interest in Maxtor hard disk drives. This manual provides technical information for OEM engineers and systems integrators regarding the installation and use of Maxtor hard drives. Drive repair should be performed only at an authorized repair center. For repair information, contact the Maxtor Customer Service Center at 800-2MAXTOR or 1-303-678-2015.

CAUTION: Maxtor hard drives are precision products. Failure to follow these precautions and guidelines outlined here may lead to product failure, damage and invalidation of all warranties.

- 1 **BEFORE** unpacking or handling a drive, take all proper electro-static discharge (ESD) precautions, including personnel and equipment grounding. Stand-alone drives are sensitive to ESD damage.
- 2 *BEFORE* removing drives from their packing material, allow them to reach room temperature.
- 3 During handling, *NEVER* drop, jar, or bump a drive.
- 4 Once a drive is removed from the Maxtor shipping container, *IMMEDIATELY* secure the drive through its mounting holes within a chassis. Otherwise, store the drive on a padded, grounded, antistatic surface.
- 5 *NEVER* switch DC power onto the drive by plugging an electrically live DC source cable into the drive's connector. *NEVER* connect a live bus to the drive's interface connector.
- 6 *ELECTRICAL GROUNDING* - For proper operation, the drive must be securely fastened to a device bay that provides a suitable electrical ground to the drive baseplate.

Please do not remove or cover up Maxtor factory-installed drive labels. They contain information required should the drive ever need repair.

Thank you for your interest in Maxtor hard disk drives. This manual provides technical information for OEM engineers and systems integrators regarding the installation and use of Maxtor hard drives. Drive repair should be performed only at an authorized repair center. For repair information, contact the Maxtor Customer Service Center at 800-2MAXTOR or 1-303-678-2015.

Table of Contents

Chapter 1

INTRODUCTION

1.1 Maxtor Corporation	1-1
1.2 Manual Organization.....	1-1
1.3 Abbreviations	1-2
1.4 Conventions.....	1-2

Chapter 2

PRODUCT DESCRIPTION

2.1 Product Description	2-1
2.2 Key Features.....	2-1
2.3 Product Features.....	2-2
2.4 Cache Management.....	2-4
2.5 Major HDA Components.....	2-4
2.6 Subsystem Configuration	2-6
2.7 Cylinder Limitation Jumper Description	2-7

Chapter 3

PRODUCT SPECIFICATIONS

3.1 Models and Capacities	3-1
3.2 Drive Configuration	3-2
3.3 Performance Specifications	3-3
3.4 Physical Dimensions	3-3
3.5 Power Requirements.....	3-5
3.6 Power Mode Definitions	3-5
3.7 EPA Energy Star Compliance	3-5
3.8 Environmental Limits	3-6
3.9 Shock and Vibration.....	3-6
3.10 Reliability Specifications.....	3-7
3.11 EMC/EMI.....	3-8
3.12 Safety Regulatory Compliance	3-8

Chapter 4

HANDLING AND INSTALLATION

4.1	Hard Drive Handling Precautions	4-1
4.2	Electro-Static Discharge (ESD)	4-1
4.3	Unpacking and Inspection	4-2
4.4	Repacking	4-5
4.5	Physical Installation	4-5

Chapter 5

ATA BUS INTERFACE AND ATA COMMANDS

5.1	INTRODUCTION	6-1
5.2	MECHANICAL INTERFACE	6-1
5.3	ELECTRICAL INTERFACE.....	6-1
5.4	REGISTER ADDRESS DECODING	6-2
5.5	COMMAND INTERFACE.....	6-2

Chapter 6

SERVICE AND SUPPORT

6.1	Service Policy	6-1
-----	----------------------	-----

Appendix A

BREAKING THE 137 GIGABYTE STORAGE BARRIER

A.1	Breaking the 137 Gigabyte Storage Barrier	A-1
-----	---	-----

List of Figures

Figure 2-1	PCBA Jumper Location and Configuration	2-6
Figure 3-1	Outline and Mounting Dimensions	3-4
Figure 4-1	Multi-pack Shipping Container	4-3
Figure 4-2	Single Pack Shipping Container (Option A)	4-4
Figure 4-3	Single Pack Shipping Container (Option B)	4-5

Chapter 1

INTRODUCTION

1.1 Maxtor Corporation

Maxtor Corporation has been providing high-quality computer storage products since 1982. Along the way, we've seen many changes in data storage needs. Not long ago, only a handful of specific users needed more than a couple hundred megabytes of storage. Today, downloading from the Internet and CD-ROMs, multimedia, networking and advanced office applications are driving storage needs even higher. Even home PC applications need capacities measured in gigabytes, not megabytes.

Products

Maxtor's products meet the demanding data storage capacity requirements of today *and* tomorrow. They are available in 5400- and 7200- RPM configurations with capacity offerings from 10 to 80 GB and beyond.

The D540X-4G drive family is a 5400 RPM hard drive with capacities from 120 GB to 160 GB.

Support

No matter which capacity, all Maxtor hard drives are supported by our commitment to total customer satisfaction and our *No Quibble Service*® guarantee. One call – or a visit to our home page on the Internet (www.maxtor.com) – puts you in touch with either technical support or customer service. We'll provide you the information you need quickly, accurately and in the form you prefer – a fax, a downloaded file or a conversation with a representative.

1.2 Manual Organization

This hard disk drive reference manual is organized in the following method:

- Chapter 1–Introduction
- Chapter 2–Product Description
- Chapter 3–Product Specifications
- Chapter 4–Handling and Installation
- Chapter 5–ATA Bus Interface and ATA Commands
- Chapter 6–Service and Support
- Appendix A–Breaking the 137GB Storage Barrier
- Glossary

1.3 Abbreviations

Abbreviation	Description	Abbreviation	Description
ATA	AT attachment	MB	megabyte
bpi	bits per inch	Mbits/sec	megabits per second
CHS	cylinder - head - sector	MB/sec	megabytes per second
db	decibels	MHz	megahertz
dBA	decibels, A weighted	ms	millisecond
DMA	direct memory access	MSB	most significant bit
ECC	error correction code	mV	millivolts
fci	flux changes per inch	ns	nanoseconds
G	acceleration	PIO	programmed input/output
GB	gigabyte	RPM	revolutions per minute
Hz	hertz	tpi	tracks per inch
KB	kilobyte	UDMA	ultra direct memory access
LBA	logical block address(ing)	µsec	microsecond
LSB	least significant bit	V	volts
mA	milliamperes	W	watts

1.4 Conventions

If there is a conflict between text and tables, the table shall be accepted as being correct.

Key Words

The names of abbreviations, commands, fields and acronyms used as signal names are in all uppercase type (e.g., IDENTIFY DRIVE). Fields containing only one bit are usually referred to as the “name” bit instead of the “name” field.

Names of drive registers begin with a capital letter (e.g., Cylinder High register).

Numbering

Numbers that are **not** followed by a lowercase “b” or “h” are decimal values. Numbers that are followed by a lowercase “b” (e.g., 01b) are binary values. Numbers that are followed by a lowercase “h” (e.g., 3Ah) are hexadecimal values.

Signal Conventions

Signal names are shown in all uppercase type.

All signals are either high active or low active signals. A dash character (-) at the end of a signal name indicates that the signal is low active. A low active signal is true when it is below V_{iL} and is false when it is above V_{iH} . A signal without a dash at the end indicates that the signal is high active. A high active signal is true when it is above V_{iH} and is false when it is below V_{iL} .

When a signal is asserted, it means the signal is driven by an active circuit to its true state.

When a signal is negated, it means the signal is driven by an active circuit to its false state.

When a signal is released, it means the signal is not actively driven to any state. Some signals have bias circuitry that pull the signal to either a true or false state when no signal driver is actively asserting or negating the signal. These instances are noted under the description of the signal.

Chapter 2

PRODUCT DESCRIPTION

2.1 Product Description

Maxtor hard disk drives are 1-inch high, 3.5-inch diameter random access storage devices which incorporate an on-board Ultra ATA/133 interface controller. High capacity is achieved by a balanced combination of high areal recording density and the latest data encoding and servo techniques.

Maxtor's latest advancements in electronic packaging and integration methods have lowered the drive's power consumption and increased its reliability.

Exceptional data transfer rates, 5400 RPM spin speed and 12 ms access times make these entry-class disk drives ideally-suited to desktop storage and consumer electronics applications.

2.2 Key Features

- ANSI ATA-5/6 compliant PIO Mode 4 interface (Enhanced IDE)
- Supports ATA-6 UltraDMA Mode 5 (100 MBytes/sec) and Maxtor Ultra ATA/133 MBytes/second data transfer rates
- Supports 48-bit addressing
- 2 MB buffer with multi-adaptive cache manager
- 5400 RPM spin speed
- 12 ms seek time
- Zone density and ID-less recording
- Outstanding shock resistance at 300 Gs
- High durability with 50K contact start/stop cycles
- Advanced multi-burst on-the-fly Error Correction Code (ECC)
- Extended data integrity with ECC protected data and fault tolerant servo synchronization fields
- Supports EPA Energy Star Standards (Green PC Friendly) with ATA powering savings commands
- Auto park and lock actuator mechanism
- Low power consumption
- SMART Capability

Note: Maxtor defines 1 Gigabyte (GB) as 10^9 or 1,000,000,000 bytes of data. Total accessible capacity varies depending on operating environment.

2.3 Product Features

Functional/Interface

Maxtor hard drives contain all necessary mechanical and electronic parts to interpret control signals and commands from an AT-compatible host computer. See Chapter 3 Product Specifications, for complete drive specifications.

Zone Density Recording

The disk capacity is increased with bit density management – common with Zone Density Recording. Each disk surface is divided into 16 circumferential zones. All tracks within a given zone contain a constant number of data sectors. The number of data sectors per track varies in different zones; the outermost zone contains the largest number of data sectors and the innermost contains the fewest.

Read/Write Multiple Mode

This mode is implemented per ANSI ATA/ATAPI-6 specification. Read/Write Multiple allows the host to transfer a set number of sectors without an interrupt request between them, reducing transfer process overhead and improving host performance.

UltraDMA-Mode 5

Maxtor hard drives fully comply with the new ANSI Ultra DMA protocol, which greatly improves overall AT interface performance by significantly improving burst and sustained data throughput.

Multi-word DMA-Mode 2

Supports multi-word Direct Memory Access (DMA) mode transfers.

Sector Address Translation

All Maxtor hard drives feature a universal translate mode. In an AT/EISA-class system, the drive may be configured to any specified combination of cylinders, heads and sectors (within the range of the drive's formatted capacity). Maxtor hard drives power-up in a translate mode:

MODELS	CYL	HD	SPT	MAX LBA	CAPACITY
4G120J6	238,216	16	63	240,121,728	122.9GB
4G160J8	317,632	16	63	320,173,056	163.9GB

Logical Block Addressing

The Logical Block Address (LBA) mode can only be utilized in systems that support this form of translation. The cylinder, head and sector geometry of the drive, as presented to the host, differs from the actual physical geometry. The host AT computer may access a drive of set parameters: number of cylinders, heads and sectors per track, plus cylinder, head and sector addresses. However, the drive can't use these host parameters directly because of zoned recording techniques. The drive translates the host parameters to a set of logical internal addresses for data access.

The host drive geometry parameters are mapped into an LBA based on this formula:

$$\begin{aligned} \text{LBA} &= (\text{HSCA} - 1) + \text{HHDA} \times \text{HSPT} + \text{HNHD} \times \text{HSPT} \times \text{HCYA} \\ &= (\text{HSCA} - 1) + \text{HSPT} \times (\text{HHDA} + \text{HNHD} \times \text{HCYA}) \end{aligned}$$

where HSCA = Host Sector Address, HHDA = Host Head Address
HCYA = Host Cylinder Address, HNHD = Host Number of Heads
HSPT = Host Sectors per Track

The LBA is checked for violating the drive capacity. If it does not, the LBA is converted to physical drive cylinder, head and sector values. The physical address is then used to access or store the data on the disk and for other drive related operations.

Defect Management Zone (DMZ)

Each drive model has a fixed number of spare sectors per drive, all of which are located at the end of the drive. Upon detection of a bad sector that has been reassigned, the next sequential sector is used.

For example, if sector 3 is flagged, data that would have been stored there is "pushed down" and recorded in sector 4. Sector 4 then effectively becomes sector 3, as sequential sectors are "pushed down" across the entire drive. The first spare sector makes up for the loss of sector 3, and so maintains the sequential order of data. This push down method assures maximum performance.

On-the-Fly Hardware Error Correction Code (ECC)

>14 symbols, single burst, guaranteed

Software ECC Correction

24 symbols, single burst, guaranteed

Automatic Park and Lock Operation

Immediately following power down, dynamic braking of the spinning disks delays momentarily allowing the read/write heads to move to an inner mechanical stop. A small fixed magnet holds the rotary actuator in place as the disk spins down. The rotary actuator is released only when power is again applied.

2.4 Cache Management

Buffer Segmentation

The data buffer is organized into two segments: the data buffer and the micro controller scratch pad. The data buffer is dynamically allocated for read and write data depending on the commands received. A variable number of read and write buffers may exist at the same time.

Read-Ahead Mode

Normally, this mode is active. Following a read request, disk read-ahead begins on the first sector and continues sequentially until the allocated buffer is full. If a read request is received during the read-ahead operation, the buffer is examined to determine if the request is in the cache. If a cache hit occurs, read-ahead mode continues without interruption and the host transfer begins immediately.

Automatic Write Reallocation (AWR)

This feature is part of the write cache and reduces the risk of data loss during deferred write operations. If a disk error occurs during the disk write process, the disk task stops and the suspect sector is reallocated to a pool of alternate sectors located at the end of the drive. Following reallocation, the disk write task continues until it is complete.

Write Cache Stacking

Normally, this mode is active. Write cache mode accepts the host write data into the buffer until the buffer is full or the host transfer is complete. A command complete interrupt is generated at the end of the transfer.

A disk write task begins to store the host data to disk. Host write commands continue to be accepted and data transferred to the buffer until either the write command stack is full or the data buffer is full. The drive may reorder write commands to optimize drive throughput.

2.5 Major HDA Components

Drive Mechanism

A brushless DC direct drive motor rotates the spindle at 5400 RPM ($\pm 0.1\%$). The dynamically balanced motor/spindle assembly ensures minimal mechanical run-out to the disks. A dynamic brake provides a fast stop to the spindle motor upon power removal. The speed tolerance includes motor performance and motor circuit tolerances.

Rotary Actuator

All Maxtor hard drives employ a rotary voice coil actuator which consists of a moving coil, an actuator arm assembly and stationary magnets. The actuator moves on a low-mass, low-friction center shaft. The low friction contributes to fast access times and low power consumption.

Read/Write Electronics

An integrated circuit mounted within the sealed head disk assembly (near the read/write heads) provides up to eight head selection depending on the model. It also provides read pre-amplification and write drive circuitry.

Read/Write Heads and Media

Low mass, low force giant magneto-resistive read/write heads record data on 3.5-inch diameter disks. Maxtor uses a sputtered thin film medium on all disks for Maxtor hard drives.

Air Filtration System

All Maxtor hard drives are assembled in a Class 100 controlled environment. Over the life of the drive, a 0.1 micron filter and breather filter located within the sealed head disk assembly (HDA) maintain a clean environment to the heads and disks. Maxtor drives are designed to operate in a typical office environment with minimum environmental control.

Microprocessor

The microprocessor controls the following functions for the drive electronics:

- Command execution
- Cache management
- Data correction and error recovery
- Diagnostic execution
- Data sequencing
- Head positioning (including error recovery)
- Host interface
- Index detection
- Spin speed control
- Seeks
- Servo
- SMART
- 48-bit addressing

2.6 Subsystem Configuration

Dual Drive Support

Two drives may be accessed via a common interface cable, using the same range of I/O addresses. The drives have a jumper configuration as device 0 or 1 (Master/Slave), and are selected by the drive select bit in the Device/Head register of the task file.

All Task File registers are written in parallel to both drives. The interface processor on each drive decides whether a command written to it should be executed; this depends on the type of command and which drive is selected. Only the drive selected executes the command and activates the data bus in response to host I/O reads; the drive not selected remains inactive.

A master/slave relationship exists between the two drives: device 0 is the master and device 1 the slave. When the Master is closed (factory default, figure 2-1), the drive assumes the role of master; when open, the drive acts as a slave. In single drive configurations, the Master jumper must be closed.

Cable Select Option

CSEL (cable select) is an optional feature per ANSI ATA specification. Drives configured in a multiple drive system are identified by CSEL's value:

- If CSEL is grounded, then the drive address is 0.
- If CSEL is open, then the drive address is 1.

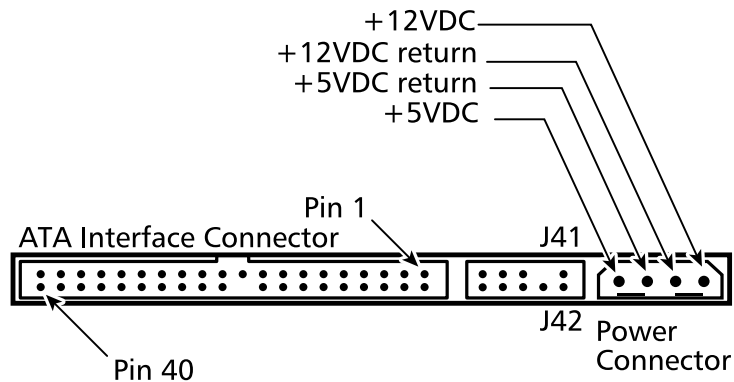

Figure 2-1 PCBA Jumper Location and Configuration

JUMPER CONFIGURATION	J49 J50	J47 J48	J45 J46	J43 J44	J41 J42
Master/Slave Only drive in single drive system* Master drive in dual drive system* Slave drive in dual drive system	C C O				
Cable Select Disabled* Enabled		O C			
Cylinder Limitation Disabled* Enabled			O C		
Factory Reserved				O	O
Key * = Default C = Closed (jumper installed) O = Open (no jumper installed)					

2.7 Cylinder Limitation Jumper Description

On some older BIOS', primarily those that auto-configure the disk drive, a hang may occur. The Cylinder Limitation jumper reduces the capacity in the Identify Drive allowing large capacity drives to work with older BIOS. The capacity reported when J45:J46 is closed will be as follows: drives less than or equal to 32GB will report 2.1GB. Drives greater than 32GB will report 32GB.

Chapter 3

PRODUCT SPECIFICATIONS

3.1 Models and Capacities

MODELS	4G120J6	4G160J8
Formatted Capacity (GB LBA Mode)	122.9GB	163.9GB
GB means 1 billion bytes. Total accessible capacity varies depending on operating environment.		

The D540X-4G at 160GB capacity (4G160J8) exceeds the 137GB capacity barrier imposed by the 28 bit addressing schemes common to many current BIOS and drivers. If your system has 28 bit addressing logic your drive will appear to only have 137GB of capacity. You can upgrade your system to break this barrier by installing a Maxtor PCI card kit (Maxtor p/n K01PCAT133). You may also be able to upgrade your system by downloading new BIOS and/or Drivers. Please visit our website www.maxtor.com/bigdrive for more information and links to diagnostic and upgrade software.

For more information on breaking the 137GB capacity barrier please refer to Appendix A.

3.2 Drive Configuration

MODELS	4G120J6	4G160J8
Data Surfaces/Number of Heads	6	8
Number of Disks	3	4
Sectors per Drive (max LBA)	240,121,728	320,173,056
Integrated Interface	Maxtor Ultra ATA/133 (ATA-5/ATA-6)	
Recording Method	PRML	
Servo Type	Embedded	
Number of Servo Sectors	224	
Data Zones per Surface	16	
Data Sectors per Track (ID/OD)	448/896	
Areal Density (Gbits/in ² max, ID/OD)	27.7/25.2	
Flux Density (kfc/i, ID/OD)	506/461	
Recording Density (kbpi, ID/OD)	486/442	
Track Density (ktpi)	57	

3.3 Performance Specifications

MODELS	4G120J6	4G160J8
Seek Times (typical read, ms)		
Track-to-Track	1	
Average (normal seek)	11	
Full Stroke (normal seek)	20	
Average Latency (ms)	5.5	
Controller Overhead (ms)	<0.3	
Rotation Speed (RPM \pm 0.1%)	5400	
Data Transfer Speed (MByte/sec max)		
To/From Interface (Maxtor Ultra ATA/133, up to)	133	
To/From Media (ID/OD up to nn.n, where nn.n is the maximum transfer rate possible)	21.9/43.4	
Sustained (ID/OD up to nn.n, where nn.n is the maximum transfer rate possible)	17.8/35.9	
Data Buffer Size (MB)/Type	2/SDRAM	
Drive Ready Time (typical sec)	7.5	

3.4 Physical Dimensions

PARAMETER	VALUE
Height (maximum in mm)	26.1
Width (typical mm)	101.6
Length (maximum in mm)	147.0
Weight (maximum in kg)	0.580

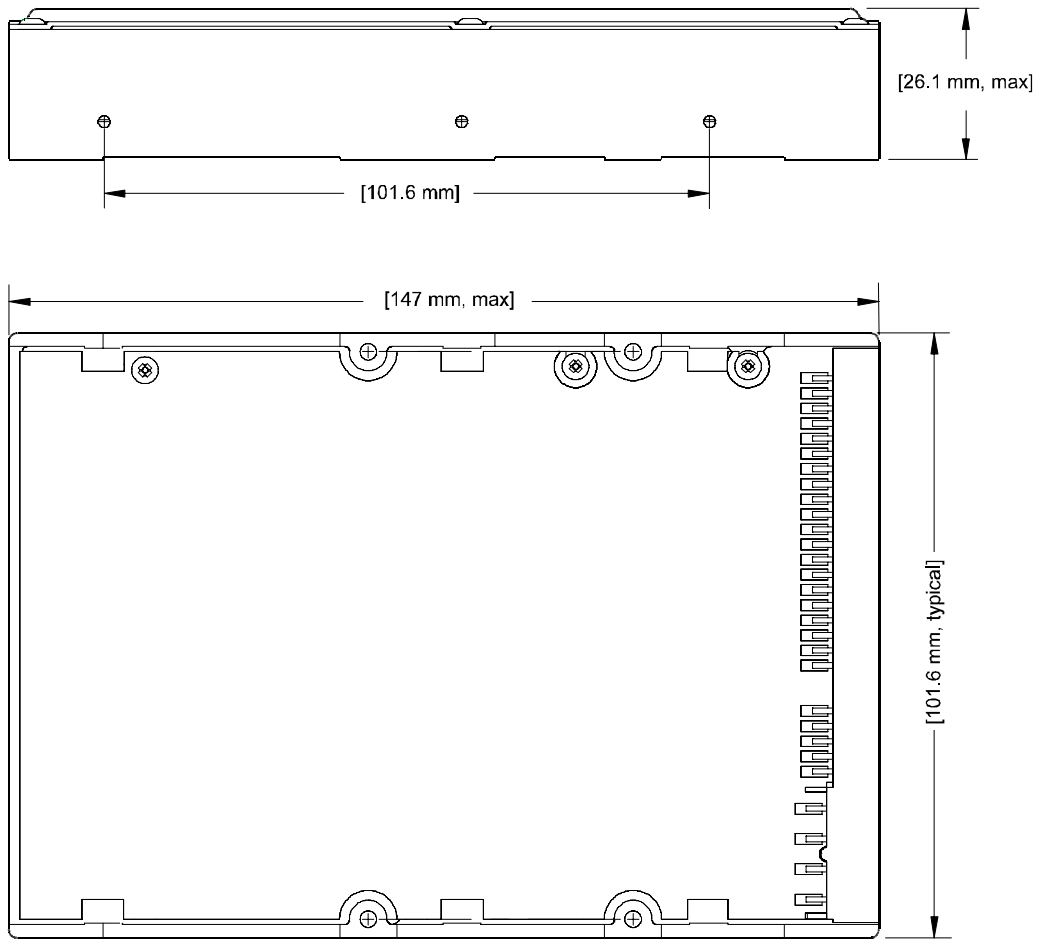

Figure 3-1 *Outline and Mounting Dimensions*

3.5 Power Requirements

MODE	12V (MA)	5V (MA)	POWER (W)
Spin-up (peak)	2100	550	31.4<0.5 sec.
Seek	881	567	13.4
Read/Write	649	561	10.6
Idle	424	566	7.9
Standby	40	307	2.0
Sleep	40	285	1.9

3.6 Power Mode Definitions

Spin-up

The drive is spinning up following initial application of power and has not yet reached full speed.

Seek

A random access operation by the drive.

Read/Write

Data is being read from or written to the drive.

Idle

The drive is spinning, the actuator is parked and powered off and all other circuitry is powered on.

The drive is capable of responding to read commands within 40 ms.

Standby

The motor is not spinning. The drive will leave this mode upon receipt of a command that requires disk access. The time-out value for this mode is programmable. The buffer is active to accept write data.

Sleep

This is the lowest power state – with the interface set to inactive. A software or hardware reset is required to return the drive to the Standby state.

3.7 EPA Energy Star Compliance

Maxtor Corporation supports the goals of the U.S. Environmental Protection Agency's Energy Star program to reduce the electrical power consumption of computer equipment.

3.8 Environmental Limits

PARAMETER	OPERATING	NON-OPERATING/ STORAGE
Temperature	0° C to 60° C	low temperature (-40° C) high temperature (65° C) per MIL-STD-810E, method 501.3, climatic category; hot-induced conditions.
Thermal Gradient	30° C per hour (maximum)	
Relative Humidity	5% to 95% (non-condensing)	
Wet Bulb	30° C (maximum)	
Altitude (relative to sea level)	-650 to 10,000 feet	-650 to 40,000 feet
Acoustic Noise - sound power (per ISO 7779, 10 microphone, at sea level)	Idle Mode (track following at speed) 3.2 bel average 3.6 bel maximum Normal Seek Mode 3.8 bel average 4.1 bel maximum	

3.9 Shock and Vibration

PARAMETER	OPERATING	NON-OPERATING
Mechanical Shock	R \geq 0.988/shock at 60 Gs; r $>$ 0.999/shock at 30 Gs	R=0.90@ \geq 250G 3&4 disk R=0.95@ \geq 225G, 3&4 disk R=0.99@ \geq 175G, 3&4 disk
Rotational Shock	R $>$ -0.988 @ 2000r/s ²	R $>$ - 0.95 @ 20K rad/sec ² , 0.5ms to 1ms input R $>$ - 0.99 @ 15K rad/sec ² , 0.5ms to 1ms input
Random Vibration	10 to 45 Hz at 0.004 G ² /Hz 48 to 62 Hz at 0.008 G ² /Hz 65 to 300 Hz at 0.004 G ² /Hz 301 to 500 Hz at 0.00005 G ² /Hz no errors	PSD: 10 Hz at 0.05 G ² /Hz 20 Hz at 0.055 G ² /Hz 300 Hz at 0.05 G ² /Hz 301 Hz at 0.0014 G ² /Hz 500-760 Hz at 0.001 G ² /Hz 877 Hz at 0.003 G ² /Hz 1000-1570 Hz at 0.001 G ² /Hz 2000 Hz at 0.0001 G ² /Hz no damage

PARAMETER	OPERATING	NON-OPERATING
Swept Sine Vibration 10 to 300 Hz	1 G (0 to peak) amplitude, .25 octave per minute	

3.10 Reliability Specifications

Annualized Return Rate

<1.0% Annualized Return Rate (ARR) indicates the average against products shipped.

Quality Acceptance Rate

<750 DPPM

The quality acceptance rate indicates the percentage of Maxtor products successfully installed by our customers, and/or the number of defective parts per million (DPPM) encountered during the entire installation process.

Start/Stop Cycles

>50,000 This indicates the average minimum cycles for reliable start/stop function.

R=0.9998 @ >4500, R=0.9995 @ >7500, R=0.5 @ >= 50000

Data Reliability

<1 per 10e15 bits read

Data errors (non-recoverable). Average data error rate allowed with all error recovery features activated.

Component Design Life

5 years (minimum)

Component design life is defined as a.) the time period before identified wear-out mechanisms impact the failure rate, or b.) the time period up to the wear-out point when useful component life expires.

3.11 EMC/EMI

3.11.1 Radiated Electromagnetic Field Emissions - EMC Compliance

The hard disk drive mechanism is designed as a subassembly for installation into a suitable enclosure and is therefore not subject to Subpart J of Part 15 of FCC Rules (47CFR15) or the Canadian Department of Communications Radio Interference Regulations. Although not required, the disk mechanism has been tested within a suitable end-use product and found to comply with Class B limits of the FCC Rules and Regulations of the Canadian Department of Communications.

The CE Marking indicates conformity with the European Union Low Voltage Directive (73/23/EEC) when the disk mechanism is installed in a typical personal computer. Maxtor recommends that testing and analysis for EMC compliance be performed with the disk mechanism installed within the user's end-use application.

3.11.2 Canadian Emissions Statement

This digital apparatus does not exceed the Class B limits for radio noise emissions from digital apparatus as set out in the radio interference regulations of the Canadian department of communications.

Le present appareil numerique n'emmet pas de bruit radioelectriques depassant les limites applicables aux appareils numeriques de Class B prescrites dans le reglement sur le brouillage radioelectrique edicte pa le ministere des communications du Canada.

3.12 Safety Regulatory Compliance

All Maxtor hard drives comply with relevant product safety standards such as CE, CUL, TUV and UL rules and regulations. As delivered, Maxtor hard drives are designed for system integration before they are used.

Chapter 4

HANDLING AND INSTALLATION

4.1 Hard Drive Handling Precautions

- If the handling precautions are not followed, damage to the hard drive may result which may void the warranty.
- During handling, *NEVER* drop, jar, or bump a drive. Handle the drive by its sides and avoid touching the printed circuit board assembly (PCBA).
- Hard drives are sensitive to electrostatic discharge (ESD) damage. Use proper ESD practices by grounding yourself and the computer system the hard drive will be installed in.
- Allow the hard drive to reach room temperature *BEFORE* installing it in your computer system.
- *NEVER* switch DC power onto the drive by plugging an electrically live DC source cable into the drive's connector. *NEVER* connect a live connector to the hard drive's IDE interface connector.
- *ELECTRICAL GROUNDING* - For proper operation, the drive must be securely fastened to a device bay that provides a suitable electrical ground to the drive baseplate.

4.2 Electro-Static Discharge (ESD)

To better avoid problems associated with ESD, Maxtor advises that anyone handling a disk drive use a wrist strap with an attached wire connected to an earth ground. Failure to observe these precautions voids the product warranty.

To reduce the incidence of ESD-related problems, Maxtor recommends that any electronics manufacturing plans include a comprehensive ESD program, the basic elements and functions of which are outlined here:

ESD Program Element	<i>ESD Program Function</i>
Management	<i>Institute and maintain</i>
Chief coordinator	<i>Organize and enforce</i>

Multi-department committee

Evaluate and improve

Employee training

Educate and inform

ESD program supplies typically include: wrist- and foot-worn grounding straps; counter-top and floor antistatic matting; wrist strap testers; ESD video and training materials. Sources for such supplies include:

Static Control Systems – 3M
225-4S, 3M Center
St. Paul, MN 55144

Desco-Charleswater
3651 Walnut Avenue
Chino, CA 91710
Phone: (909) 627-8178
Fax: (909) 627-7449
www.charleswater.com

Maxtor also offers a complete video training package, “Care and Handling of Maxtor Disk Drives.” Contact your Maxtor representative for details.

4.3 Unpacking and Inspection

Retain any packing material for reuse. Inspect the shipping container for evidence of damage in transit. Notify the carrier immediately in case of damage to the shipping container.

As they are removed, inspect drives for evidence of shipping damage or loose hardware. If a drive is damaged (and no container damage is evident), notify Maxtor immediately for drive disposition.

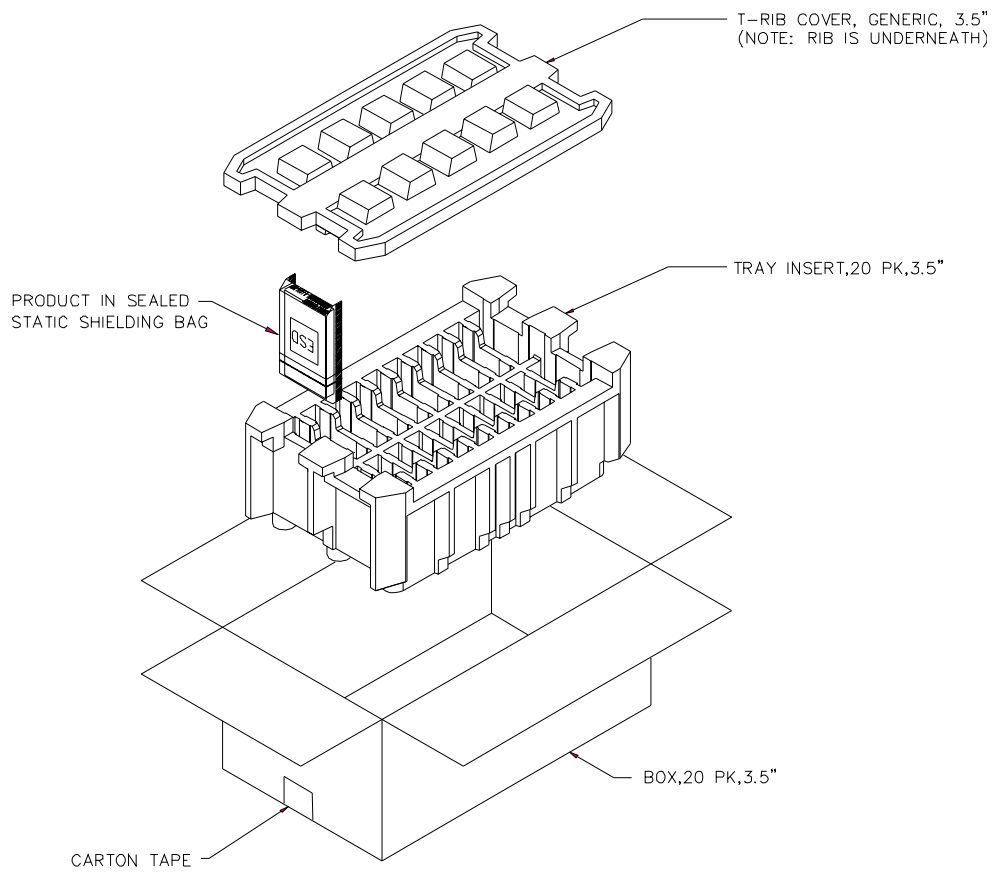

Figure 4-1 Multi-pack Shipping Container

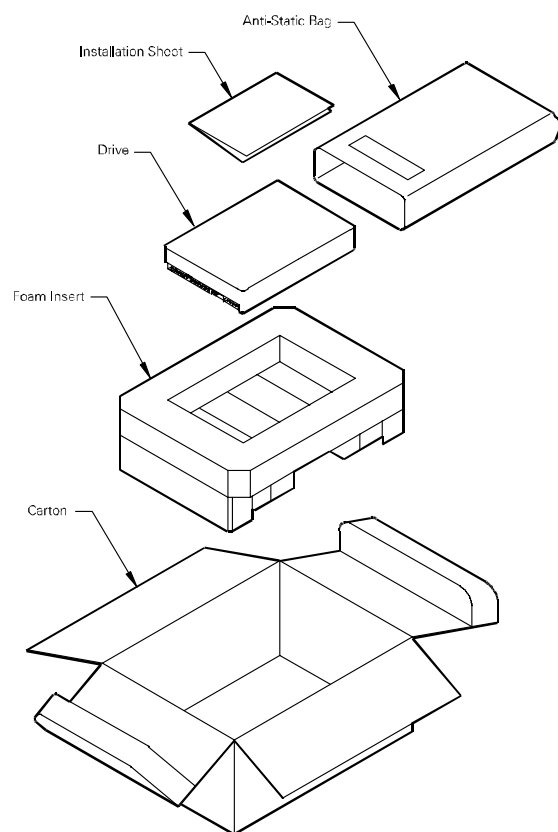

Figure 4-2 Single Pack Shipping Container (Option A)

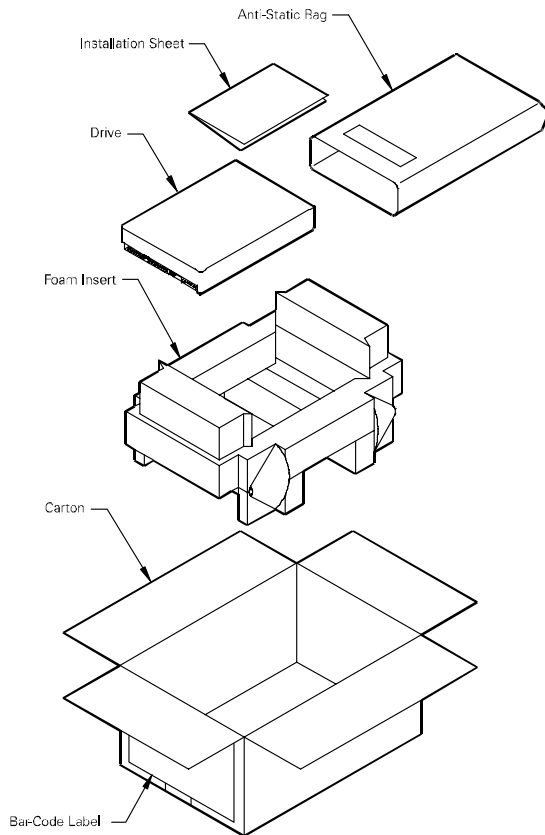

Figure 4-3 *Single Pack Shipping Container (Option B)*

4.4 Repacking

If a Maxtor drive requires return, repack it using Maxtor packing materials, including the antistatic bag.

4.5 Physical Installation

The detailed installation instructions for Maxtor hard drives are provided in the Installation Guide. To obtain a copy of the Installation Guide please visit Maxtor's web site at www.maxtor.com and select the product family to view or download the correct installation information for this product.

Chapter 5

ATA BUS INTERFACE AND ATA COMMANDS

This chapter describes the interface between Maxtor D540X-4G hard disk drives and the ATA bus. The commands that are issued from the host to control the drive are listed, as well as the electrical and mechanical characteristics of the interface.

5.1 INTRODUCTION

Maxtor D540X-4G hard disk drives use the standard ATA/ATAPI interface. Support of various options in the standard are explained in the following sections.

5.2 MECHANICAL INTERFACE

5.2.1 Signal Cable and Connector

The Maxtor D540X-4G hard disk drive contains a 40-pin unitized connector for both signal and power connections as well as configuration jumpers. The dimensions and specifications of the unitized connector comply with Annex. A in the ATA/ATAPI standard.

The Maxtor D540X-4G drives require the use of an 80 conductor cable (ATA/ATAPI-6, Annex. A, Figure A.4 and description) to support the drive's Ultra DMA capability.

5.3 ELECTRICAL INTERFACE

5.3.1 ATA Bus Interface

5.3.1.1 Electrical Characteristics

Signals on the ATA interface are assigned to connector pins according to Annex. A in the ATA/ATAPI-6 standard for the 80 conductor cable assembly. The signaling protocol complies with clause 9 and signal timing complies with clause 10 of the standard.

The Maxtor D540X-4G hard disk drives support all Ultra DMA Data Transfer modes (0 - 5) defined in the ATA/ATAPI-6 standard. In addition, these drives support Mode 6, and can send and receive data at the full 133MB/s transfer rate.

Hosts may assert the RESET- signal for longer than the minimum. When power is applied with RESET- asserted, the Maxtor D540X-4G disk media will not begin to spin up until RESET- is negated. This may reduce maximum current consumption for the overall system.

5.4 REGISTER ADDRESS DECODING

The Maxtor D540X-4G hard disk drives allow their host systems to address the full set of command and control registers as specified in clause 7 of the ATA/ATAPI-6 standard. This includes the 48-bit Address feature set described in clause 6.

5.5 COMMAND INTERFACE

5.5.1 General Feature Set

The μ Processor, Disk Controller, and ATA Interface electronics are contained in a proprietary ASIC developed by Maxtor.

5.5.2 Supported Commands

The Maxtor D540X-4G hard disk drives support all the mandatory commands from the general feature set for devices not supporting the Packet command feature set. Refer to the ATA/ATAPI-6 standard for a detailed description of these commands.

Table 5-1 lists the supported commands.

Table 5-1 *Supported Commands*

Command	Command Code	Feature Register Value(s)
CHECK POWER MODE	98h, E5h	
DEVICE CONFIGURATION FREEZE LOCK	B1h	C1h
DEVICE CONFIGURATION IDENTIFY	B1h	C2h
DEVICE CONFIGURATION RESTORE	B1h	C0h
DEVICE CONFIGURATION SET	B1h	C3h
DOWNLOAD MICROCODE	92h	07h, 01h
EXECUTE DRIVE DIAGNOSTIC	90h	
FLUSH CACHE	E7h	
IDENTIFY DRIVE	ECh	
IDLE	97h, E3h	
IDLE IMMEDIATE	95h, E1h	
NOP	00h	
READ BUFFER	E4h	

Table 5-1 *Supported Commands*

Command	Command Code	Feature Register Value(s)
READ DMA	C8h, C9h	
READ LONG	22h, 23h	
READ MULTIPLE	C4h	
READ NATIVE MAX ADDRESS	F8h	
READ SECTOR(S)	20h, 21h	
READ VERIFY SECTOR(S)	40h, 41h	
SECURITY DISABLE PASSWORD	F6h	
SECURITY ERASE PREPARE	F3h	
SECURITY ERASE UNIT	F4h	
SECURITY FREEZE LOCK	F5H	
SECURITY SET PASSWORD	F1h	
SECURITY UNLOCK	F2h	
SEEK	70h	
SET FEATURES	EFh	Note 1
SET MAX ADDRESS	F9h	00h
SET MAX SET PASSWORD	F9h	01h
SET MAX LOCK	F9h	02h
SET MAX UNLOCK	F9h	03h
SET MAX FREEZE LOCK	F9h	04h
SET MULTIPLE MODE	C6h	
SLEEP	99h, E6h	
SMART DISABLE OPERATIONS	B0h	D9h
SMART ENABLE OPERATIONS	B0h	D8h
SMART ENABLE/DISABLE ATTRIBUTE AUTOSAVE	B0h	D2h
SMART EXECUTE OFF-LINE IMMEDIATE	B0h	D4h

Table 5-1 *Supported Commands*

Command	Command Code	Feature Register Value(s)
SMART READ DATA	B0h	D0h
SMART READ LOG	B0h	D5h
SMART RETURN STATUS	B0h	DAh
SMART SAVE ATTRIBUTE VALUES	B0h	D3h
SMART WRITE LOG	B0h	D6h
STANDBY	96h, E2h	
STANDBY IMMEDIATE	94h, E0h	
WRITE BUFFER	E8h	
WRITE DMA	CAh, CBh	
WRITE MULTIPLE	C5h	
WRITE PIO OVERLAP	34h	
WRITE SECTOR(S)	30h, 31h	

Note: 1. As defined in the ATA/ATAPI-6 standard.

Chapter 6

SERVICE AND SUPPORT

6.1 Service Policy

If a customer discovers a defect in a Maxtor hard drive, Maxtor will, at its option, repair or replace the disk drive at no charge to the customer, provided it is returned during the warranty period. Drives must be properly packaged in Maxtor packaging or Maxtor-approved packaging to obtain warranty service. Any unauthorized repairs or adjustments to the drive void the warranty.

To consistently provide our customers with the best possible products and services, Maxtor developed the Total Customer Satisfaction (TCS) program. Through the ongoing TCS process, Maxtor employees take direct responsibility for every customer's level of satisfaction – with Maxtor technology, price, quality, delivery, service and support.

No Quibble Service[®]

Another TCS feature is Maxtor's *No Quibble Service* policy. By minimizing paperwork and processing, *No Quibble Service* dramatically cuts the turnaround time normally required for repairs and returns. Here's how it works:

1. Customer visits www.maxtor.com or calls 1-800-2MAXTOR for a Return Material Authorization (RMA) number and provides a credit card number
2. Maxtor ships a replacement drive within 2 business days
3. Customer returns the original drive and credit card draft is destroyed.

Product Support

Technical Assistance/Customer Service

For the current up-to-date information, hours of operation, phone numbers and worldwide email accounts, on how to contact Maxtor Technical support and Product Support please go to Maxtor's web site at www.maxtor.com and click on the 'Contact' link at the top of the page.

Appendix A

BREAKING THE 137 GIGABYTE STORAGE BARRIER

This appendix provides information about the 137GB storage barrier. It discusses the history, cause and the solution to overcome this barrier.

A.1 Breaking the 137 Gigabyte Storage Barrier

Capacity barriers have been a fact of the personal computer world since its beginnings in the early 1980's. At least 10 different capacity barriers have occurred in the storage industry over the last 15 years. The most notable barriers seen previously have been at 528 megabytes and then at 8.4 gigabytes.

The most recent barrier which will be surmounted in 2001, is the 137-gigabyte limit or a single ATA drive. The first ATA devices to exceed 137 gigabytes will be four-platter hard disk drives with 40 gigabytes per platter, yielding 160 gigabytes per drive. These drives will be available in the second half of 2001. Later in the same year, capacity will continue to grow to 60 gigabytes per platter, and a three-disk, 180-gigabyte device will be available and shipping.

The ANSI NCITS T13 Technical Committee (also known as the ANSI ATA committee) has broken this barrier by incorporating a proposal from Maxtor into the ATA/ATAPI-6 draft standard that defines a method for 48-bit addressing on a single drive, giving more than 144 petabytes (144,000 gigabytes) of storage.

In addition, the proposal from Maxtor that was incorporated into ATA/ATAPI-6 defines a method for extending the maximum amount of data that can be transferred per command for ATA devices from 256 sectors (about 131 kilobytes) to 65,536 sectors (about 33 megabytes). This new method is particularly useful for applications that use extremely large files, such as those for A/V or multimedia.

The following sections will describe issues surrounding the 137-gigabyte barrier and the solution for breaking it.

A.1.1 History

Many of the "barriers" in the past resulted from BIOS and operating system issues caused by failure to anticipate the remarkable increases in device storage capacity by the people who designed hard disk structures, access routines, and operating systems many years ago. They thought, "Who will ever have xxx much storage?" In some cases, the barriers were caused by hardware or software bugs not found until hard disks had grown in size beyond a certain point where the bugs would occur.

Past barriers often frustrated people trying to add a new hard disk to an older system when they discovered that not all of the designed capacity of the hard disk was accessible. This inability to access the entire drive is referred to as a “capacity barrier” and it has been seen and overcome many times in the computer and disk drive industry.

The 137-gigabyte barrier is the result of the original design specification for the ATA interface that provided only 28 bits of address for data. This specification means a hard disk can have a maximum of 268,435,456 sectors of 512 bytes of data which puts the ATA interface maximum at 137.4 gigabytes.

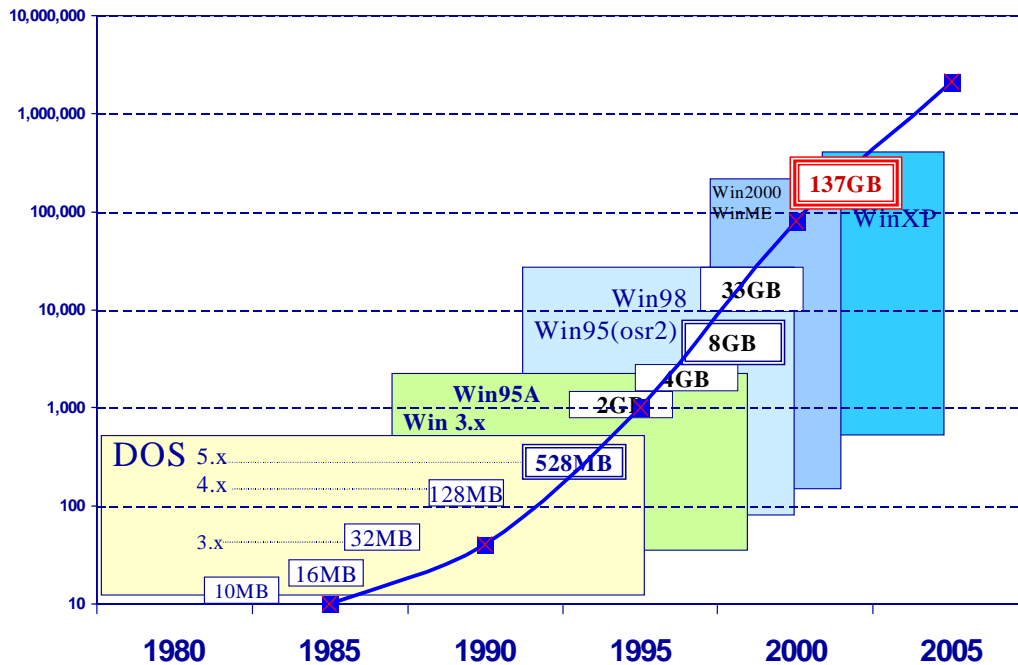

- | | |
|--|---|
| 10 megabytes: early PC/XT limit | PC/XT limit |
| 16 megabytes: FAT 12 limit | FAT 12 limit |
| 32 megabytes: DOS 3.x limit | DOS 3.x limit |
| 128 megabytes: DOS 4.x limit | DOS 4.x limit |
| 528 megabytes: Early ATA BIOSs without BIOS extensions | Early ATA BIOSs without BIOS extensions |
| 2.1 gigabytes: DOS file system partition limit | DOS file system partition limit |
| 4.2 gigabytes: CMOS extended CHS addressing limit (not widely experienced) | CMOS extended CHS addressing limit (not widely experienced) |
| 8.4 gigabytes: BIOS/Int13 24-bit addressing limit | BIOS/Int13 24-bit addressing limit |
| 32 gigabytes: BIOS limit | BIOS limit |

A.1.2 Solving the 137 Gigabyte Capacity Barrier

As described earlier, the issue causing the 137-gigabyte barrier is the 28-bit addressing method of the original ATA specification. A change to expand this method was required to provide more address bits for the interface, allowing significant growth for many years to come. A critical issue in expanding the addressing capability was maintaining compatibility with the existing installed base of products.

A new ATA standard, ATA/ATAPI-6, has been in the works for some time, and the latest draft of this standard resolves this issue by increasing the maximum number of bits used for addressing from 28 to 48. This solution increases the maximum capacity of an ATA device to 144 petabytes while maintaining compatibility with current ATA products.

A.1.3 How is the Extension Implemented?

The 48-bit Address feature set provides a method to address devices with capacities up to approximately 144 petabytes by increasing the number of bits used to specify logical block addresses (LBAs) from 28 to 48. The feature set also provides a method to increase the number of sectors that can be transferred by a single command from 256 to 65,536 by increasing the number of bits specifying sector count to 16 bits.

New commands specific to this feature set have been defined so that devices can implement the new feature set in addition to previously defined commands. Devices implementing the 48-bit Address feature set commands will also implement commands that use 28-bit addressing in order to maintain interoperability with older system components. In addition, 8-bit and 48-bit commands may be intermixed.

The 48-bit Address feature set operates in LBA addressing only. Support of the 48-bit Address feature set is indicated in the IDENTIFY DEVICE response data. In a device implementing the 48-bit Address feature set, the registers used for addressing are, in fact, a two-byte deep FIFO. Each time one of these registers is written, the new content written is placed into the "most recently written" location and the previous content of the register is moved to "previous content" location. A host may read the "previous content" of the registers by first setting a bit in the Device Control register to 1 and then reading the desired register.

A.1.4 What Do the Drives Need to Meet the Spec?

The challenge to drive manufacturers is to develop and implement new interface chips on drives that can accept and decode the new 48-bit addressing scheme. Many functions of decoding the commands sent to and from the drive are automated in the silicon of the drive interface ASIC, and this is where drive manufacturers must update their designs. Maxtor is the leader in development efforts and is the first to deliver a product with the capacity and drive technology to deliver greater than 137 gigabytes of capacity.

A.1.5 What Else is Involved?

Effort is required from OS vendors to increase storage device addressing up to 48 bits or more. This increase will be a significant challenge for many OS vendors that have 32-bit code models. Adapting to 48-bit commands will be easy, but most vendors will stop filling data at the 32-bit boundary and pad the upper 16 bits with zeros, leaving that space empty.

The BIOS companies will also have to perform some work to recognize the increased capacity of the devices attached to the bus and allow the extended 48-bit commands to pass on to the devices. Boot partitions will also be an issue for the capacity of the drive if the BIOS does not recognize the 48-bit addressing scheme at or before the system boots the OS from the hard drive.

Independent software driver efforts for legacy operating systems (Windows NT 4, Windows 98, and so on) will need to be implemented to allow higher-capacity devices to work on installed systems and recognize the maximum available capacity of the drive over the 137-gigabyte limit.

A.1.6 What is the Next Barrier?

While it is true that the ATA/ATAPI-6 standard defines a method to provide a total capacity for a device of 144 petabytes, the next limit will be imposed not by the ATA devices but by many of the popular operating systems in use today. This limit will be at 2.2 terabytes (2,200 gigabytes). This barrier exists because many of today's operating systems are based on 32-bit addressing. These operating systems include many flavors of Linux, Mac OS 9.x, and Windows 95, 98, ME, NT 4, 2000, and XP (Windows XP/64-bit also has the limit because of leveraged 32-bit code).

This barrier could be real as early as 2004 if current hard drive capacity rate increases continue along the same growth trends.

Appendix A: Terminology

- **BIOS:** (an acronym for Basic Input/Output System design): The BIOS processes and redirects all data as it is being accessed and stored.
- **FAT:** (an acronym for File Allocation Table): The FAT tells the computer where data has been stored on the hard drive.
- **CHS:** (an acronym for Cylinders, Heads, and Sectors): The basic layout components of a hard drive. INT 13h & INT 13h extensions: protocols used for accessing data on hard drives.

Appendix B: Big Numbers

- 131 kilobytes = 131,000 bytes
a little more than 30 pages of text
- 33 megabytes = 33,000,000 bytes
more than 8,000 pages of text or 25 300-page books
- 137 gigabytes = 137,000,000,000 bytes
more than 100,000 books, or the contents of a good library
- 2.2 terabytes = 2,200,000,000,000 bytes
almost 2,000,000 books, or the about content of the Library of Congress
- 144 petabytes = 144,000,000,000,000,000 bytes
120 billion books – (more than all that man has written)
- 9.4 zettabytes = 9,400,000,000,000,000,000 bytes

Appendix C: Resources

- Maxtor “Big Drive” web site for resource information:
<http://www.maxtor.com/bigdrive>
- ATA/ATAPI-6: <http://www.T13.org>

GLOSSARY

A

ACCESS – (v) Read, write, or update information on some storage medium, such as a disk. (n) One of these operations.

ACCESS TIME – The interval between the time a request for data is made by the system and the time the data is available from the drive. Access time includes the actual seek time, rotational latency, and command processing overhead time. See also seek, rotational latency, and overhead.

ACTUATOR – Also known as the *positioner*. The internal mechanism that moves the read/write head to the proper track. The Maxtor actuator consists of a rotary voice coil and the head mounting arms. One end of each head mounting arm attaches to the rotor with the read/write heads attached at the opposite end of each arm. As current is applied to the rotor, it rotates, positioning the heads over the desired cylinder on the media.

AIRLOCK – A patented Maxtor feature that ensures durable and reliable data storage. Upon removal of power from the drive for any reason, the read/write heads automatically park and lock in a non data area called the landing zone. AIRLOCK allows the drive to withstand high levels of non-operating shock. When power is applied to the drive, airflow created from the spinning disks causes the AIRLOCK arm to swing back and unlock the actuator, allowing the heads to move from the landing zone. Upon power down, the AIRLOCK swings back to the locked position, locking the heads in the landing zone. A park utility is not required to park the heads on drives equipped with AIRLOCK (all Maxtor drives).

ALLOCATION – The process of assigning particular areas of the disk to particular files. See also allocation unit.

ALLOCATION UNIT – An allocation unit, also known as a *cluster*, is a group of sectors on the disk that can be reserved for the use of a particular file.

AVERAGE SEEK TIME – The average time it takes for the read/write head to move to a specific location. To compute the average seek time, you divide the time it takes to complete a large number of random seeks all over the disk by the number of seeks performed.

B

BACKUP – A copy of a file, directory, or volume on a separate storage device from the original, for the purpose of retrieval in case the original is accidentally erased, damaged, or destroyed.

BAD BLOCK – A block (usually the size of a sector) that cannot reliably hold data because of a media flaw or damaged format markings.

BAD TRACK TABLE – A label affixed to the casing of a hard disk drive that tells which tracks are flawed and cannot hold data. The listing is typed into the low-level formatting program when the drive is being installed. Because Maxtor disk drive's defect-management scheme handles all such flaws automatically, there is no need to concern yourself with bad track tables.

BIT – Abbreviation for binary digit. A binary digit may have one of two values—1 or 0. This contrasts with a decimal digit, which may have a value from 0 to 9. A bit is one of the logic 1 or logic 0 binary settings that make up a byte of data. See also byte.

BLOCK – A sector or group of sectors. By default, a block of data consists of 512 bytes.

BPI – Abbreviation for *bits per inch*. A measure of how densely information is packed on a storage medium. Flux changes per inch is also a term commonly used in describing storage density on a magnetic surface.

BUFFER – An area of RAM reserved for temporary storage of data that is waiting to be sent to a device that is not yet ready to receive it. The data is usually on its way to or from the disk drive or some other peripheral device.

BUS – The part of a chip, circuit board, or interface designed to send and receive data.

BYTE – The basic unit of computer memory, large enough to hold one character of alphanumeric data. Comprised of eight bits. See also bit.

C

CACHE – Random-access memory used as a buffer between the CPU and a hard disk. Information more likely to be read or changed is placed in the cache, where it can be accessed more quickly to speed up general data flow.

CAPACITY – The amount of information that can be stored on a disk drive. The data is stored in bytes, and capacity is usually expressed in megabytes.

CDB – Command Descriptor Block. The SCSI structure used to communicate requests from an initiator (system) to a target (drive).

CLEAN ROOM – An environmentally controlled dust-free assembly or repair facility in which hard disk drives are assembled or can be opened for internal servicing.

CLUSTER – A group of sectors on a disk drive that is addressed as one logical unit by the operating system.

CONTROLLER – Short form of *disk controller*. The chip or complete circuit that translates computer data and commands into a form suitable for use by the disk drive.

CONTROLLER CARD – An adapter holding the control electronics for one or more hard disks, usually installed in a slot in the computer.

CPU – Acronym for *Central Processing Unit*. The microprocessor chip that performs the bulk of data processing in a computer.

CRC – Acronym for *Cyclic Redundancy Check*. An error detection code that is recorded within each sector and is used to see whether parts of a string of data are missing or erroneous.

CYLINDER – On a disk drive that has more than one recording surface and heads that move to various tracks, the group of all tracks located at a given head position. The number of cylinders times the number of heads equals the number of tracks per drive.

D

DATA SEPARATOR – On a disk drive that stores data and timing information in an encoded form, the circuit that extracts the data from the combined data and clock signal.

DEDICATED SERVO – A surface separate from the surface used for data that contains only disk timing and positioning information and contains no data.

DEFECT MANAGEMENT – A method that is implemented to ensure long term data integrity. Defect management eliminates the need for user defect maps. This is accomplished by scanning the disk drives at the factory for defective sectors. Defective sectors are deallocated prior to shipment. In addition, during regular use, the drive continues to scan and compensate for any new defective sectors on the disk.

DISK – In general, any circular-shaped data-storage medium that stores data on the flat surface of the platter. The most common type of disk is the magnetic disk, which stores data as magnetic patterns in a metal or metal-oxide coating. Magnetic disks come in two forms: floppy and hard. Optical recording is a newer disk technology that gives higher capacity storage but at slower access times.

DISK CONTROLLER – A plug-in board, or embedded circuitry on the drive, that passes information to and from the disk. The Maxtor disk drives all have controllers embedded on the drive printed-circuit board.

DISKWARE – The program instructions and data stored on the disk for use by a processor.

DMA – Acronym for *direct memory access*. A process by which data moves directly between a disk drive (or other device) and system memory without passing through the CPU, thus allowing the system to continue processing other tasks while the new data is being retrieved.

DRIVE – Short form of *disk drive*.

DRIVE GEOMETRY – The functional dimensions of a drive in terms of the number of heads, cylinders, and sectors per track. See also logical format.

E

ECC – Acronym for *error correction code*. The recording of extra verifying information encoded along with the disk data. The controller uses the extra information to check for data errors, and corrects the errors when possible.

EMBEDDED SERVO – A timing or location signal placed on the disk's surface on the tracks that also store data. These signals allow the actuator to fine-tune the position of the read/write heads.

ENCODING – The protocol by which particular data patterns are changed prior to being written on the disk surface as a pattern of On and Off or 1 and 0 signals.

EXTERNAL DRIVE – A drive mounted in an enclosure separate from the PC or computer system enclosure, with its own power supply and fan, and connected to the system by a cable.

FAT – Acronym for *file allocation table*. A data table stored on the outer edge of a disk that tells the operating system which sectors are

allocated to each file and in what order.

FCI – Acronym for *flux changes per inch*. See also BPI.

FILE SERVER – A computer that provides network stations with controlled access to shareable resources. The network operating system is loaded on the file server, and most shareable devices (disk subsystems, printers) are attached to it. The file server controls system security and monitors station-to-station communications. A dedicated file server can be used only as a file server while it is on the network. A non dedicated file server can be used simultaneously as a file server and a workstation.

FLUX DENSITY – The number of magnetic field patterns that can be stored in a given length of disk surface. The number is usually stated as flux changes per inch (FCI), with typical values in the thousands.

FLYING HEIGHT – The distance between the read/write head and the disk surface caused by a cushion of air that keeps the head from contacting the media. Smaller flying heights permit more dense storage of data, but require more precise mechanical designs.

FORMAT – To write onto the disk surface a magnetic track pattern that specifies the locations of the tracks and sectors. This information must exist on a disk before it can store any user data. Formatting erases any previously stored data.

FORMATTED CAPACITY – The amount of room left to store data on the disk after the required space has been used to write sector headers, boundary definitions, and timing information generated by a format operation. All Maxtor drive capacities are expressed in formatted capacity.

FORM FACTOR – The physical outer dimensions of a device as defined by industry standard. For example, most Maxtor disk drives use a 3 1/2-inch form factor.

G

GIGABYTE (GB) – One billion bytes (one thousand megabytes).

GUIDE RAILS – Plastic strips attached to the sides of a disk drive mounted in an IBM AT and compatible computers so that the drive easily slides into place.

H

HALF HEIGHT – Term used to describe a drive that occupies half the vertical space of the original full size 5 1/4-inch drive. 1.625 inches high.

HARD DISK – A type of storage medium that retains data as magnetic patterns on a rigid disk, usually made of an iron oxide or alloy over a magnesium or aluminum platter. Because hard disks spin more rapidly than floppy disks, and the head flies closer to the disk, hard disks can transfer data faster and store more in the same volume.

HARD ERROR – A repeatable error in disk data that persists when the disk is reread, usually caused by defects in the media surface.

HEAD – The tiny electromagnetic coil and metal pole piece used to create and read back the magnetic patterns (write and read information) on the media.

HIGH-CAPACITY DRIVE – By industry conventions typically a drive of 1 gigabytes or more.

HIGH-LEVEL FORMATTING – Formatting performed by the operating system's format program. Among other things, the formatting program creates the root directory and file allocation tables. See also low-level formatting.

HOME – Reference position track for recalibration of the actuator, usually the outer track (track 0).

HOST ADAPTER – A plug-in board that forms the interface between a particular type of computer system bus and the disk drive.

I

INITIALIZE – See low level formatting.

INITIATOR – A SCSI device that requests another SCSI device to perform an operation. A common example of this is a system requesting data from a drive. The system is the initiator and the drive is the target.

INTERFACE – A hardware or software protocol, contained in the electronics of the disk controller and disk drive, that manages the exchange of data between the drive and computer.

INTERLEAVE – The arrangement of sectors on a track. A 1:1 interleave arranges the sectors so that the next sector arrives at the read/write heads just as the computer is ready to access it. See also interleave factor.

INTERLEAVE FACTOR – The number of sectors that pass beneath the read/write heads before the next numbered sector arrives. When the interleave factor is 3:1, a sector is read, two pass by, and then the next is read. It would take three revolutions of the disk to access a full track of data. Maxtor drives have an interleave of 1:1, so a full track of data can be accessed within one revolution of the disk, thus offering the highest data throughput possible.

INTERNAL DRIVE – A drive mounted inside one of a computer's drive bays (or a hard disk on a card, which is installed in one of the computer's slots).

J

JUMPER – A tiny box that slips over two pins that protrude from a circuit board. When in place, the jumper connects the pins electrically. Some board manufacturers use Dual In-Line Package (DIP) switches instead of jumpers.

K

KILOBYTE (K) – A unit of measure consisting of 1,024 (2^{10}) bytes.

L

LANDING ZONE – A position inside the disk's inner cylinder in a non data area reserved as a place to rest the heads during the time that power is off. Using this area prevents the heads from touching the surface in data areas upon power down, adding to the data integrity and reliability of the disk drive.

LATENCY – The period of time during which the read/write heads are waiting for the data to rotate into position so that it can be accessed. Based on a disk rotation speed of 3,662 rpm, the maximum latency time is 16.4 milliseconds, and the average latency time is 8.2 milliseconds.

LOGICAL FORMAT – The logical drive geometry that appears to an AT system BIOS as defined by the drive tables and stored in CMOS. With an installation program like Disk Manager, the drive can be redefined to any logical parameters necessary to adapt to the system drive tables.

LOOK AHEAD – The technique of buffering data into cache RAM by reading subsequent blocks in advance to anticipate the next request for data. The look ahead technique speeds up disk access of sequential blocks of data.

LOW-LEVEL FORMATTING – Formatting that creates the sectors on the platter surfaces so the operating system can access the required areas for generating the file structure. Maxtor drives are shipped with the low-level formatting already done.

LOW PROFILE – Describes drives built to the 3 1/2-inch form factor, which are only 1 inch high.

M

MB – See megabyte.

MEDIA – The magnetic film that is deposited or coated on an aluminum substrate which is very flat and in the shape of a disk. The media is overcoated with a lubricant to prevent damage to the heads or media during head take off and landing. The media is where the data is stored inside the disk in the form of magnetic flux or polarity changes.

MEGABYTE (MB) – A unit of measurement equal to 1,024 kilobytes, or 1,048,576 bytes except when referring to disk storage capacity.

1 MB = 1,000,000 bytes when referring to disk storage capacity.

See also kilobyte.

MEGAHERTZ – A measurement of frequency in millions of cycles per second.

MHz – See megahertz.

MICROPROCESSOR – The integrated circuit chip that performs the bulk of data processing and controls the operation of all of the parts of the system. A disk drive also contains a microprocessor to handle all of the internal functions of the drive and to support the embedded controller.

MICROSECOND (μ s) – One millionth of a second (.000001 sec.).

MILLISECOND (ms) – One thousandth of a second (.001 sec.).

MTBF – Mean Time Between Failure. Used as a reliability rating to determine the expected life of the product expressed in power on hours (POH). There are several accepted methods for calculating this value that produce very different results and generate much confusion in the industry. When comparing numbers you should first verify which method was used to calculate the values.

MTTR – Mean Time To Repair. The average time it takes to repair a drive that has failed for some reason. This only takes into consideration the changing of the major sub-assemblies such as circuit board or sealed housing. Component level repair is not included in this number as this type of repair is not performed in the field.

N

NANOSECOND (ns)– One billionth of a second (0.000000001 second).

O

OVERHEAD – The processing time of a command by the controller, host adapter or drive prior to any actual disk accesses taking place.

OVERWRITE – To write data on top of existing data, erasing it.

OXIDE – A metal-oxygen compound. Most magnetic coatings are combinations of iron or other metal oxides, and the term has become a general one for the magnetic coating on tape or disk.

P

PARTITION – A portion of a hard disk devoted to a particular operating system and accessed as one logical volume by the system.

PERFORMANCE – A measure of the speed of the drive during normal operation. Factors affecting performance are seek times, transfer rate and command overhead.

PERIPHERAL – A device added to a system as an enhancement to the basic CPU, such as a disk drive, tape drive or printer.

PHYSICAL FORMAT – The actual physical layout of cylinders, tracks, and sectors on a disk drive.

PLATED MEDIA – Disks that are covered with a hard metal alloy instead of an iron-oxide compound. Plated disks can store greater amounts of data in the same area as a coated disk.

PLATTER – An disk made of metal (or other rigid material) that is mounted inside a fixed disk drive. Most drives use more than one platter mounted on a single spindle (shaft) to provide more data storage surfaces in a small package. The platter is coated with a magnetic material that is used to store data as transitions of magnetic polarity.

POH – Acronym for *power on hours*. The unit of measurement for Mean Time Between Failure as expressed in the number of hours that power is applied to the device regardless of the amount of actual data transfer usage. See MTBF.

POSITIONER – See actuator.

R

REDUNDANT ARRAY OF INDEPENDENT DISKS (RAID) - is a way of storing the same data in different places (thus, redundantly) on multiple hard disks. By placing data on multiple disks, I/O operations can overlap in a balanced way, improving performance. Since multiple disks increases the mean time between failure (MTBF), storing data redundantly also increases fault-tolerance.

A RAID appears to the operating system to be a single logical hard disk. RAID employs the technique of *striping*, which involves partitioning each drive's storage space into units ranging from a sector (512 bytes) up to several megabytes. The stripes of all the disks are interleaved and addressed in order.

RAID – See redundant array of independent disks

RAM – Acronym for *random access memory*. An integrated circuit memory chip which allows information to be stored and retrieved by a microprocessor or controller. The information may be stored and retrieved in

any order desired, and the address of one storage location is as readily accessible as any other.

RAM DISK – A “phantom disk drive” for which a section of system memory (RAM) is set aside to hold data, just as if it were a number of disk sectors. The access to this data is extremely fast but is lost when the system is reset or turned off.

READ AFTER WRITE – A mode of operation that has the computer read back each sector on the disk, checking that the data read back is the same as recorded. This slows disk operations, but raises reliability.

READ VERIFY – A disk mode where the disk reads in data to the controller, but the controller only checks for errors and does not pass the data on to the system.

READ/WRITE HEAD – The tiny electromagnetic coil and metal pole piece used to create and read back the magnetic patterns (write or read information) on the disk. Each side of each platter has its own read/write head.

REMOVABLE DISK – Generally said of disk drives where the disk itself is meant to be removed, and in particular of hard disks using disks mounted in cartridges. Their advantage is that multiple disks can be used to increase the amount of stored material, and that once removed, the disk can be stored away to prevent unauthorized use.

RLL – Run Length Limited. A method used on some hard disks to encode data into magnetic pulses. RLL requires more processing, but stores almost 50% more data per disk than the MFM method.

ROM – Acronym for *read only memory*. Usually in the form of an ROM in the controller that contains programs that can be accessed and read but not modified by the system.

ROTARY ACTUATOR – The rotary actuator replaces the stepper motor used in the past by many hard disk manufacturers. The rotary actuator is perfectly balanced and rotates around a single pivot point. It allows

closed-loop feedback positioning of the heads, which is more accurate than stepper motors.

ROTATIONAL LATENCY – The delay between when the controller starts looking for a specific block of data on a track and when that block rotates around to where it can be read by the read/write head. On the average, it is half of the time needed for a full rotation (about 8 ms.).

S

SCSI – Acronym for *Small Computer System Interface*, an American National Standards Institute (ANSI) version of Shugart Associates' SASI interface between the computer and controller. SCSI has grown in popularity and is one of the most flexible and intelligent interfaces available.

SECTOR – A section of space along a track on the disk, or the data that is stored in that section. Hard disks most often have sectors that are 512 data bytes long plus several bytes overhead for error correcting codes. Each sector is preceded by ID data known as a header, which cannot be overwritten.

SEEK – A movement of the disk read/write head in or out to a specific track.

SERVO DATA – Magnetic markings written on the media that guide the read/write heads to the proper position.

SERVO SURFACE – A separate surface containing only positioning and disk timing information but no data.

SETTLE TIME – The interval between when a track to track movement of the head stops, and when the residual vibration and movement dies down to a level sufficient for reliable reading or writing.

SHOCK RATING – A rating (expressed in Gs) of how much shock a disk drive can sustain without damage.

SOFT ERROR – An error in reading data from the disk that does not recur if the same data is reread. Often caused by power

fluctuations or noise spikes.

SOFT SECTORED – Disks that mark the beginning of each sector of data within a track by a magnetic pattern.

SPINDLE – The center shaft of the disk upon which the drive's platters are mounted.

SPUTTER – A type of coating process used to apply the magnetic coating to some high-performance disks. In sputtering, the disks are placed in a vacuum chamber and the coating is vaporized and deposited on the disks. The resulting surface is hard, smooth, and capable of storing data at high density. Maxtor disk drives use sputtered thin film disks.

STEPPER – A type of motor that moves in discrete amounts for each input electrical pulse. Stepper motors used to be widely used for read/write head positioner, since they can be geared to move the head one track per step. Stepper motors are not as fast or reliable as the rotary voice coil actuators which Maxtor disk drives use.

SUBSTRATE – The material the disk platter is made of beneath the magnetic coating. Hard disks are generally made of aluminum or magnesium alloy (or glass, for optical disks) while the substrate of floppies is usually mylar.

SURFACE – The top or bottom side of the platter which is coated with the magnetic material for recording data. On some drives one surface may be reserved for positioning information.

T

TERABYTE (TB) – A unit of measurement to 1,024 gigabytes (GB), or 1,099,511,627,776 bytes, except when referring to disk storage capacity. Storage capacities of one or more terabytes is achieved by installing multiple hard drive in a RAID system. 1 TB = 1,000,000,000,000 bytes when referring to disk storage capacity. See also gigabyte.

THIN FILM – A type of coating, used for disk surfaces. Thin film surfaces allow more bits to be stored per disk.

TPI – Acronym for *tracks per inch*. The number of tracks or cylinders that are written in each inch of travel across the surface of a disk.

TRACK – One of the many concentric magnetic circle patterns written on a disk surface as a guide to where to store and read the data.

TRACK DENSITY – How closely the tracks are packed on a disk surface. The number is specified as tracks per inch (TPI).

TRACK TO TRACK SEEK TIME – The time required for the read/write heads to move to an adjacent track.

TRANSFER RATE – The rate at which the disk sends and receives data from the controller. Drive specifications usually reference a high number that is the burst mode rate for transferring data across the interface from the disk buffer to system RAM. Sustained data transfer is at a much lower rate because of system processing overhead, head switches, and seeks.

U

Ultra DMA – (UDMA, or, more accurately, Ultra DMA/133) is a protocol for transferring data between a hard disk drive through the computer's data paths (or bus) to the computer's random access memory (RAM). The Ultra DMA/133 protocol transfers data in burst mode at a rate of 133 MBps (megabytes per second), twice as fast as the previous Direct Memory Access (DMA) interface.

UNFORMATTED CAPACITY – The total number of bytes of data that could be fit onto a disk. Formatting the disk requires some of this space to record location, boundary definitions, and timing information. After formatting, user data can be stored on the remaining disk space, known as formatted capacity. The size of a Maxtor drive is expressed in formatted capacity.

V

VOICE COIL – A type of motor used to move the disk read/write head in and out to the right track. Voice-coil actuators work like loudspeakers with the force of a magnetic coil causing a proportionate movement of the head. Maxtor's actuator uses voice-coil technology, and thereby eliminates the high stress wearing parts found on stepper motor type actuators.

W

WEDGE SERVO – The position on every track that contains data used by the closed loop positioning control. This information is used to fine tune the position of the read/write heads exactly over the track center.

WINCHESTER DISKS – Hard disks that use a technology similar to an IBM model using Winchester as the code name. These disks use read/write heads that ride just above the magnetic surface, held up by the air flow created by the turning disk. When the disk stops turning, the heads land on the surface, which has a specially lubricated coating. Winchester disks must be sealed and have a filtration system since ordinary dust particles are large enough to catch between the head and the disk.

WRITE ONCE – In the context of optical disks, technologies that allow the drive to store data on a disk and read it back, but not to erase it.

Free Manuals Download Website

<http://myh66.com>

<http://usermanuals.us>

<http://www.somanuals.com>

<http://www.4manuals.cc>

<http://www.manual-lib.com>

<http://www.404manual.com>

<http://www.luxmanual.com>

<http://aubethermostatmanual.com>

Golf course search by state

<http://golfingnear.com>

Email search by domain

<http://emailbydomain.com>

Auto manuals search

<http://auto.somanuals.com>

TV manuals search

<http://tv.somanuals.com>