

**(1)- (MAYTAG) TOP LOAD WASHER VIBRATION  
REDUCTION KIT #12001736.**

# Instruction Sheet

16010016  
2606860-0299

This instruction she

**REPAIR PART NO.:** 12001736

**DESCRIPTION:** Vibration Reduction Kit

**CONTENTS:**

Qty.	MCS Part no.	Description
1	12001702	Plastic Plugs (Pkg. Of 2)
6	22002782	Foam Pads (Cabinet to base vibra
2	22002966	U-Nuts (Front panel vibration)
2	216423	Screws, Console to Top Cover
1	22001817	Asphaltic Pad
1	16010016	Instruction Sheet

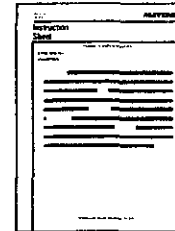

Although vibration is attributed to unlevel appliances or weak flooring, the components of this kit are put together to aid the service technician in the home when addressing loose cabinet metal to baseframe and front panel vibration. First identify the source of the vibration complaint on the product. The following general instructions are intended to be followed by a trained technical service technician familiar with the tear down and servicing of Maytag washers.

## REAR LEVELING LEG SYSTEM:

Check rear leveling leg system. Verify the pins are fully inserted through the leveling legs. Apply some lithium grease to the top of the stabilizer arm beneath the mounting bracket. (Figure 1)

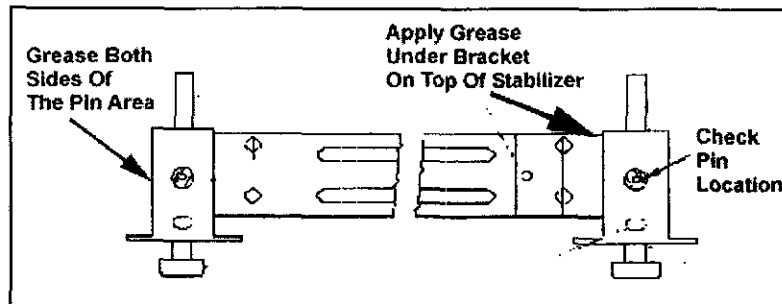

**Figure 1**

## FRONT PANEL NOISE:

1. Disconnect electrical power to washer.
2. Remove the front panel of the washer.
3. Locate the package containing the two plastic plugs in the kit. Press the plugs into the flange of the cabinet. *(Figure 2)*

The plugs will bow the front panel slightly, thus stiffening the panel and eliminating panel vibration.

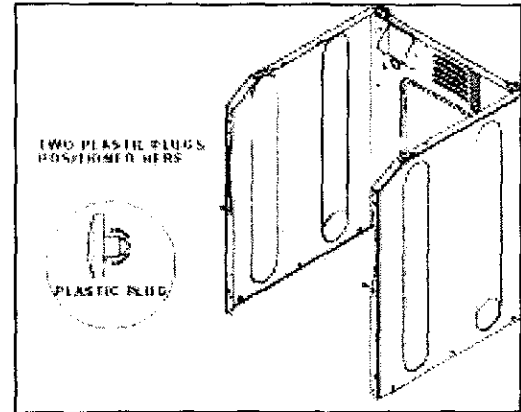

Figure 2

4. Locate the two "U" nut tinnermans in the kit.
5. Remove the two screws securing the "J" clips to the baseframe. *(Figure 3)*
6. Position the "U" nut tinnermans onto the baseframe over the two screw holes.
7. Remount the "J" clips to the baseframe by screwing into the "U" nut tinnermans on the base frame.

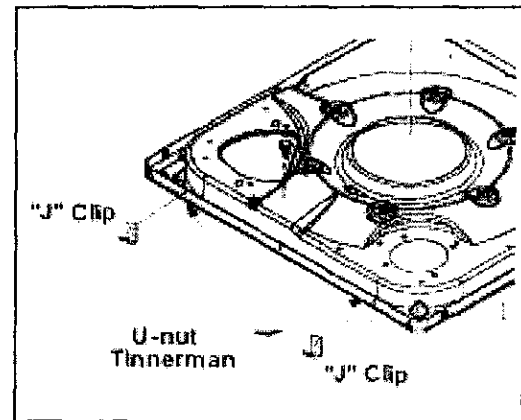

Figure 3

## CABINET TO BASE NOISE:

1. Disconnect electrical power to washer.
2. Remove the front panel of the washer.
3. Locate the package containing the six small foam pads in the kit. Loosen the screws securing the cabinet to baseframe.
4. Insert a foam pad between the inside of the cabinet and the baseframe and retighten the screws securing the cabinet to baseframe. *(Figure 4)*

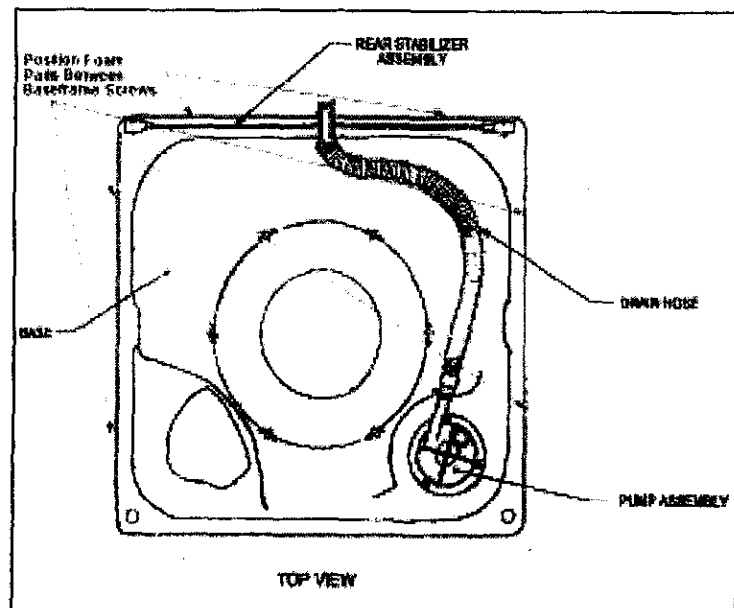
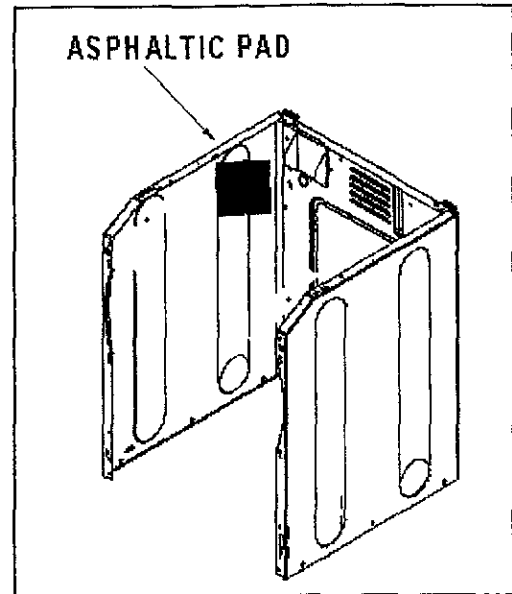

Figure 4

## LOOSE CABINET NOISE

1. Disconnect electrical power to washer.
2. Remove the front panel and lift the top cover or remove the rear access panel.
3. Locate the asphaltic pad in the kit. Clean the surface area as indicated in *Figure 5*.
4. Peel the backing from the pad and position the pad onto the cabinet. Apply pressure to the pad to firmly attach the pad to the cabinet.
5. Lower the top cover and remount the front panel.



*Figure 5*

## CONSOLE TO TOP COVER

1. Disconnect electrical power to washer.
2. Remove the rear panel of the console.
3. Locate the two console reattachment screws in the kit. Insert the screws through the base of the console and into the top cover. Fasten the screws down into the top cover. (*Figure 6*)
4. Reattach rear control console panel.

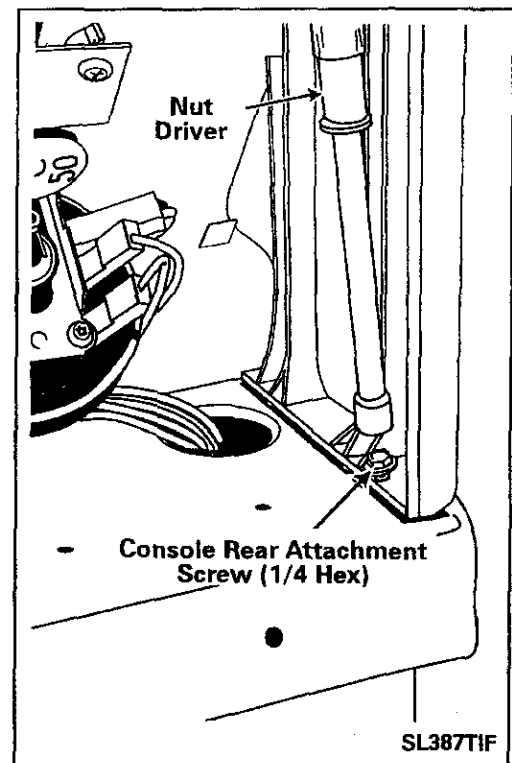

*Figure 6*

## Free Manuals Download Website

<http://myh66.com>

<http://usermanuals.us>

<http://www.somanuals.com>

<http://www.4manuals.cc>

<http://www.manual-lib.com>

<http://www.404manual.com>

<http://www.luxmanual.com>

<http://aubethermostatmanual.com>

Golf course search by state

<http://golfingnear.com>

Email search by domain

<http://emailbydomain.com>

Auto manuals search

<http://auto.somanuals.com>

TV manuals search

<http://tv.somanuals.com>