

TMB Optical TMB-130

Thomas M. Back Signature Series

Thank you and congratulations on your purchase of this TMB Optical TMB-130 130mm f/7 ED apochromatic triplet refractor. Its optical and mechanical quality will give you many years of observing enjoyment.

TELESCOPE MOUNTS

Your new TMB-130 is usable with many different types of telescope mounts. A suitably sturdy altazimuth mount is a good choice for most purely visual observing. An altazimuth mount is typically light in weight, easy to set up, and is relatively low-priced. Just be sure that the mount is capable of handling the scope's weight (which will be well over 20 pounds after adding mounting rings, diagonal, eyepiece, etc.)

A high quality German equatorial mount would be an excellent choice for both visual and imaging purposes. The very stable German-type equatorial mount can be driven in both right ascension and declination for photography and CCD imaging, as well as for uninterrupted visual observing. The quality of your images will not only depend on the optical quality of your telescope, but your local conditions (the seeing and how dark your site is), the tracking accuracy of your mount, your imaging equipment, and your guiding and image processing techniques.

TUBE RINGS

No tube mounting rings are supplied with your TMB refractor. However, well-machined 142mm TMB hinged split rings are available from your telescope dealer.

FOCUSER

Your TMB-130 has a dual speed Starlight Instruments Feather Touch Model FTF3545 rack-and-pinion focuser. This ultra-premium focuser has a long travel 3.5" diameter drawtube for non-vignetted astrophotography with

medium format film cameras and very large chip CCD cameras. The drawtube ends in a 2" accessory adapter with a non-marring soft brass compression ring eyepiece holder that will not damage the barrels of your 2" eyepieces and accessories. This adapter allows visual use with 2" star diagonals and eyepieces, plus imaging with 35mm film cameras and 2" barrel large format CCD cameras.

The 2" accessory adapter is secured to the focuser drawtube by three recessed hex-head screws. Undoing these allows you to remove the supplied 2" adapter and replace it with a custom-made Feather Touch adapter for medium format (Pentax 6 x 7) film photography using A-P photographic accessories. Please contact Starlight Instruments directly at (847) 985-9595 for any specialized adapters you may need in this regard.

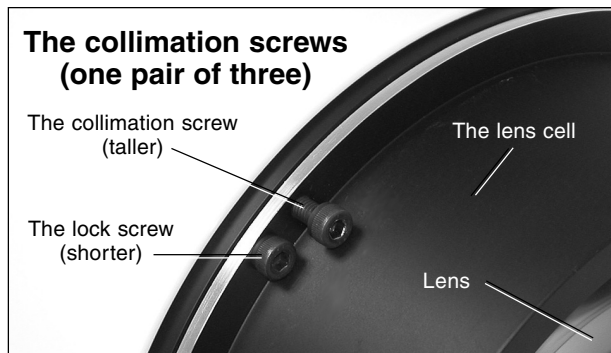

the shorter of the pair is the lock screw that holds the proper collimation after adjustment. Be sure to adjust only one set of collimation screws at a time. Loosen the lock screws before attempting to turn the collimating screws. Make only small changes at a time (turning the collimating screw only a fraction of a turn and checking to see the results before turning further).

When you finish adjusting the collimating screws, be sure to snug down all lock screws to hold the correct collimation. Do not over-tighten the lock screws, but make sure they are firmly in place. Once collimation is complete, your objective lens will be on the same optical axis as the eyepiece, camera, or CCD, and you will obtain the best possible optical performance.

The other method of collimation is to examine a first or second magnitude star image at high power at night after the scope has reached thermal equilibrium. This collimation method requires an equatorially-mounted scope and a motor drive to keep the star image centered while you adjust the collimation screws. It is generally a more difficult and time-consuming collimation method than using a Cheshire eyepiece, as you are working with a small and droppable Allen wrench in the dark and are at the mercy of changing seeing conditions.

Be sure not to choose a closely-spaced binary star as your test star. Do not use a star diagonal when collimating, as you may be attempting to correct a problem in the diagonal, rather than in the telescope. Adjust the push-pull collimation screws until the star images are tight and round, and the first and second diffraction rings are uniform in their intensity all the way around the Airy disk.

THE STAR TEST

We strive to make the best apochromatic optical systems available. You may find your lens may not test "perfect" during an extended and stringently-graded "star test," particularly if the scope has not fully reached thermal equilibrium before the test. This is not an indication of a poor optic. It is rather due to the test star's complex wavefront of light that is being constantly changed by our living atmosphere as seeing conditions vary from minute to minute, from second to second.

No optic is perfect and likewise, under a detailed and extended star test, every telescope optic will show some error. The sensitivity of the star test under *perfect* conditions is 1/20th wave P-V on the wavefront for third order

aberrations, and 1/60th wave for sharp (fifth order) aberrations. It is highly unlikely that even the most ardent observer can see errors of this small a magnitude, even under very good seeing conditions (which is when the atmosphere typically presents a 1/4th wave P-V wavefront to the telescope and eye).

Something else to consider in star-testing refractors: the change in spherical aberration with a change in wavelength. This is called "spherochromatism" and is found in the wavefront of all refractors. What this means is that as the lens is tested in the longer (red) wavelengths, the lens becomes "under-corrected," and in the shorter wavelengths (blue), the lens becomes "over-corrected." These overlapping corrections at different wavelengths change the star test pattern from perfection.

So, while star tests are interesting and useful, most observers spend their nights enjoying the heavens, not just examining points of light. We feel that the proof of optical excellence is in the observing, not just in the testing.

All TMB objectives are corrected at the peak visual wavelength, which is centered at around 560nm in the green-yellow portion of the visual spectrum. The eye sees over 80% of the visual detail at this wavelength, and it is the proper correction at this visual peak that makes the difference between just a good objective, and a superb one. We design and figure our lenses for the best possible wavefront at the green-yellow wavelengths, to give you the sharpest images and highest contrast possible.

A FINAL WORD

We thank you for your purchase of this TMB-130. We believe that this apochromatic refractor will outperform any other telescope type, inch for inch, and is the most trouble-free telescope that you can buy. Its versatility in visual, photographic, and CCD work is unmatched. With a little care, this fine apochromatic refractor will last you a lifetime. Please enjoy the wonders of the night sky!

Tom Back

SOME BRIEF SPECIFICATIONS

Aperture	130mm (5.1")
Focal Length	910mm
Focal Ratio	f/7
Objective Type	air-spaced ED triplet apochromatic
Optical coatings	fully multicoated
Resolving Power (Dawes' Limit)	0.89 arc seconds
Visual Limiting Magnitude	13.1
Light Grasp Versus the Eye	345x
Focuser	FeatherTouch #FTF3545 rack and pinion with dual-speed and 11:1 reduction ratio fine focus; 2" and 1.25" compression ring eyepiece holders; 360° rotating camera angle adjuster
Focuser Travel	4.33" (110mm)
Tube Diameter	142mm (5.6") o. d.
Tube Length (lens shade retracted)	28.75" (730mm)
Tube Length (lens shade extended)	34.5" (876mm)
Optical Tube Weight	18.7 lbs. (8.5 kg)

TMB Optical, P.O. Box 44331, Cleveland, OH 44144 (216) 524-1107

E-mail: TMBoptical@aol.com

© 2007 by TMB Optical

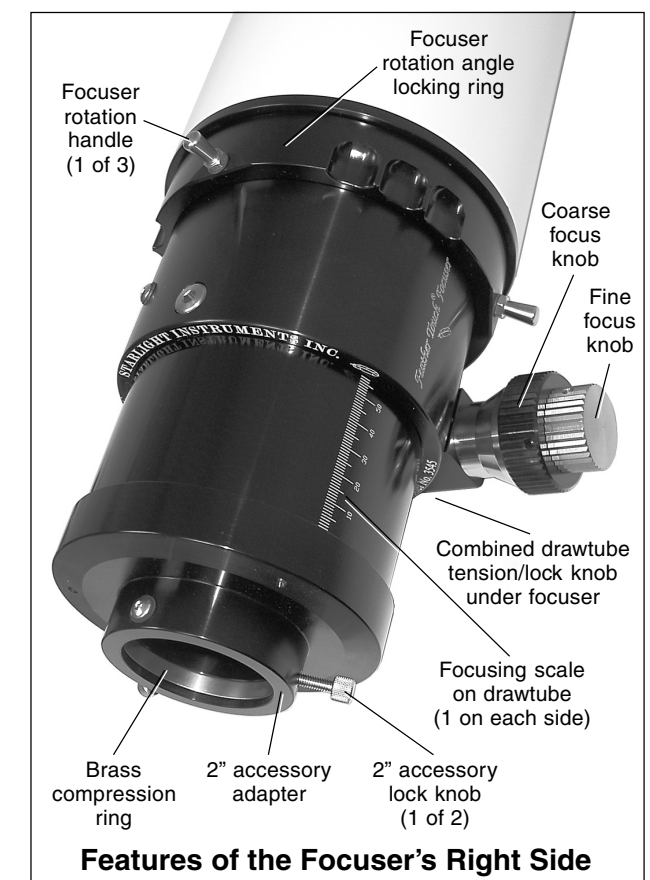

Features of the Focuser's Right Side

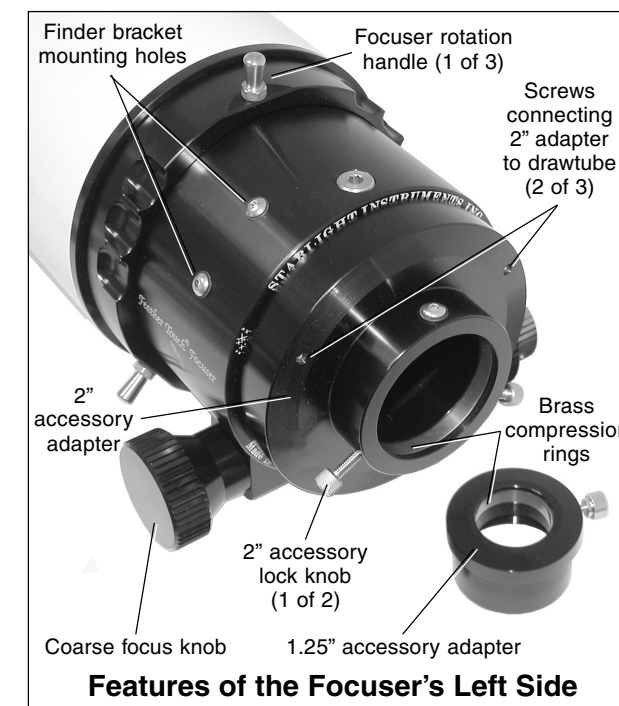

Features of the Focuser's Left Side

The supplied 2" to 1.25" accessory adapter is designed for visual use with 1.25" star diagonals and accessories, plus imaging with standard format CCD, webcam, and 35mm adapters. This adapter also uses a non-marring soft brass compression ring to hold your 1.25" star diagonals and accessories in place. The barrel of this adapter is threaded to accept standard 2" filters and has a slight inward taper at the top. The taper engages the compression ring of the 2" adapter to prevent the 1.25" adapter from slipping out of the focuser, should the 2" adapter's thumb-screw accidentally loosen during use.

Your Feather Touch focuser has dual-speed focusing. There are two coarse focusing knobs. The right knob also has a smaller concentric knob with a 10:1 ratio reduction gear for microfine focusing. This provides exceptionally precise image control during high power visual observing and critical film or CCD imaging. The focus knobs have ribbed gripping surfaces so they are easy to operate, even while wearing gloves or mittens in cold weather.

Your focuser drawtube has a long 110mm (4.33") travel. It has two scales (one on either side) that are laser-engraved in 1mm increments. These let you note individual focuser positions for easy return to the correct focus when switching between visual use and photography.

Because your Feather Touch focuser is so smooth in operation and moves so freely, it can only hold a limited amount of weight (generally about 1 lb.) without drifting out of focus when the focuser drawtube is not horizontal and has a significant vertical component. The focuser therefore contains an adjustable-tension internal brake system to allow astrophotography and visual use with heavy eyepieces without the possibility of focus shift.

The brake consists of a lever arrangement within the focuser's pinion block. Adjusting the thumbscrew underneath the pinion block causes the lever to press a friction pad onto the pinion. This increases the torque needed to turn the focus knobs. If the thumbscrew is turned all the way in (only 1 to 1½ turns), the pinion shaft and drawtube are locked into position at the desired focus for long exposure imaging. Visually, partial tightening of the internal brake offers a virtually infinite range of braking force to accommodate various eyepiece and accessory weights.

A built-in camera angle adjuster (focuser rotation system) lets you rotate the focuser a full 360° without losing focus. This lets you rotate the focuser to line up a camera in either a landscape or portrait orientation (or any orientation in between). It also lets you put your star diagonal and eyepiece in the most comfortable observing position as you move from one area of the sky to another.

Three focuser rotation handles and recessed finger grips in the locking ring around the front of the focuser body let you adjust the focuser rotation angle. While holding the 2" accessory adapter of the focuser steady with one hand, use the rotation handles to turn the locking ring slightly counterclockwise to unlock the focuser. Rotate the focuser to the desired new orientation. While again holding the 2" accessory adapter steady, turn the locking ring back clockwise to lock the focuser in place at the new angle.

Your focuser drawtube glides on three stainless steel straps that mate with Teflon bearing surfaces to provide very tight yet extremely smooth motion. This design eliminates the need for grease between the housing and drawtube. A greaseless drawtube prevents the collection of dirt that may eventually cause problems between these surfaces, so no routine focuser maintenance is required except for an occasional wipe down of the drawtube with a soft cloth.

FINDERSCOPE

No finderscope is provided with your TMB-130. However, there are two holes for a finder bracket drilled and tapped on 1.25" centers at the 10 o'clock position on the rear of the focuser. These holes will accept any of a number of finderscope mounting rings. Contact your telescope

dealer for an appropriate finder if you do not already have one that is suitable.

COOL DOWN TIMES

For any optical system to give its best wavefront (sharpest and highest contrast images), the optics must be at or very near the temperature of the surrounding air. This "cool down" time needed to reach ambient temperature varies considerably, as the temperature of the telescope must change from a typical 72° Fahrenheit indoor temperature to an outdoor temperature that can range from a high of over 100° down to 20° below zero or less.

With small doublet refractors, the cool down (or heat up) time is quick, usually less than 30 minutes. In larger refractors, or in subfreezing temperatures, it can take a telescope one to two hours to reach its best performance. This is particularly true with triplet refractors, where the thermal load of the center lens is isolated from the surrounding air by the lenses on either side of it. This slows the transfer of the center lens heat load to the outside air.

If you'd like to shorten the wait to reach thermal equilibrium in backyard observing, place your telescope in an unheated garage for a few hours before observing. This can shorten the cool down process considerably.

Another technique for shortening cool down time in the field is to retract the dew shield to allow direct exposure of the lens cell and lens to the night air so they reach thermal equilibrium faster. Refractors show a noticeable undercorrection during cool down. By comparing a star's image on both sides of focus you can determine when the images are similar and the lens is near optimum correction. At this point, slide the dew shield back out to its fully extended position. This provides a quicker cool down time, and will generally still keep the lens from dewing up.

Only on the highest dew point nights will the objective form dew on the front optical surface. If you live in a high humidity climate, however, we recommend the regular use of a dew heater strip.

The best way to avoid dew forming on the lens after you bring your telescope into the house is to take your closed telescope carrying case outside with your scope, where the case can also reach ambient temperature. When you are finished observing, cap your telescope with its dust caps and place it into the carrying case. Bring it into the house and let it slowly warm back up to room temperature, then remove the dust caps to allow any trace of dew to evaporate. Once the objective is free from dew, replace the dust caps and store your scope away.

CLEANING

The best policy is not to let your lens get dirty and/or dusty in the first place. The use of the dust caps is highly recommended. However, no amount of preventative measures will stop the objective from eventually collecting dust and airborne pollutants on the first optical surface.

We recommend that you do not clean the objective too often, no matter how frequently the urge to do so may hit you. A few specks of debris on the lens will not be visible in your images, as they are not in the focal plane. They don't block enough light to measure, let alone be seen.

Depending on how often you use your scope, and the amount of pollutants in your air, you may have to clean your scope as often as twice a year, but generally no more

than that – and preferably no more than once a year. If the front lens surface becomes dusty, smeared, or shows fingerprints or any other surface build-up, and you find it absolutely necessary to clean the lens, use the following technique to clean it.

First, gently blow away any surface dust or particles with a clean air blower (a child's ear syringe or a photographer's camel's hair brush with attached blower bulb, for example). The use of canned or compressed air should be avoided, if possible, as the propellant in the can may spit out and leave difficult-to-remove deposits on your lens. Also, the expanding compressed air drops in temperature as it leaves the can. The cold air coming out of the tiny tube that most compressed air cans use to direct the air flow has been known to chill a lens to the point of spalling glass chips off the lens if pointed at the same spot on the lens too closely for too long.

If you want, or need, to use compressed air to remove stubborn particles, use a high quality compressed air duster (the R-134 propellant type). ChemTronics sells a high-quality unit. Do not tip or shake the can. Blow any loose particles off your lens surface using short blasts at an angle to the glass, without getting too close to the lens surface or aiming directly at it.

Moisten a ball of USP grade pure cotton with a few drops of a photographic-quality optical cleaning solution designed for multic coated camera and binocular lenses. You can use Formula MC (available from many telescope dealers) or your own mixture of distilled water and a drop or two of mild soap. A well-worn 100% cotton handkerchief also works well and Zeiss and Kodak both make suitable cleaning fluids. Blot the lens surface with the dampened cotton ball or cloth to pick up any stubborn particles and to clean the surface. Exchange the cotton ball and/or turn the cloth frequently so you always have a clean portion of the cotton ball or cloth in contact with the lens.

Use a very small amount of liquid – not so much that the fluid could be wicked between the lenses by capillary action. Do not drip the cleaning fluid directly onto your lens. Do not, at any stage, apply hard pressure. Using a fresh piece of cotton or a lint-free white facial tissue, carefully clean the surface of the lens by wiping from the center to the edge in a radial direction. Repeat the process with denatured alcohol, blowing off any dust that may fall on the lens as you are cleaning it.

If you want to take the ultimate step in cleaning, a final rinse with HPLC grade acetone, or any high-grade acetone, will clean the surface to new condition. You may notice a few faint streaks on the lens from the dried solvent. They will not affect performance, but can be removed if desired with light pressure and a Q-Tip slightly moistened with a small amount of alcohol or acetone. Finally, a few short blasts of air from a clean air blower bulb can be used to remove any remaining dust.

Avoid overcleaning your scope. The multic coatings on the lens are quite hard and durable. However, frequent overzealous cleaning can scratch the coatings if all the dust particles (which are often tiny flecks of windborne rock) are not removed before you start pushing a damp tissue around the lens surface. Clean your optics only when absolutely necessary. If you take proper care of your scope,

cleaning should rarely be needed.

COLLIMATION

Your telescope was carefully collimated prior to shipment to your dealer. With normal care the optics will keep that alignment permanently. However, if the telescope takes a very strong blow in shipping or while transporting it to your observing site, there is the small possibility that you may have to recollimate the lens. The lens cell has three pairs of push-pull collimating screws that will allow you to collimate it using a metric Allen wrench.

To gain access to the collimation screws, remove the black trim ring/knife-edge baffle from the front of the dew shield by unthreading it in a counter-clockwise direction. Set it aside and push the dew shield back on the optical tube until the front of the dew shield clears the lens cell and exposes the collimation screws at the rear of the lens cell, as shown in the illustration below.



We recommend either of two collimation methods. In the first, a "Cheshire" eyepiece (available from Tectron or your telescope dealer) is inserted directly into the eyepiece holder (without using a star diagonal). The Cheshire method can be used indoors or in the field, day or night.

The dust cover is placed over the lens cell to seal the objective end of the scope and keep light from entering the optical tube. A bright light source is aimed at the opening in the side of the Cheshire eyepiece. You can use the light from the sky outdoors during the day. At night or indoors, aim the light of a flashlight directly at the opening in the side of the Cheshire.

Look through the hole in the end of the Cheshire. You will see a series of faint circles of reflected light against a black background. If the circles of light are all concentric, your scope is in collimation. If the circles of light are not concentric, adjust the push-pull collimation screws until you line up the off-center circles to form a single round circle. The illustration on the next page shows a close-up of one of the pairs of collimation screws.

The taller screw is the actual collimation screw, while

Free Manuals Download Website

<http://myh66.com>

<http://usermanuals.us>

<http://www.somanuals.com>

<http://www.4manuals.cc>

<http://www.manual-lib.com>

<http://www.404manual.com>

<http://www.luxmanual.com>

<http://aubethermostatmanual.com>

Golf course search by state

<http://golfingnear.com>

Email search by domain

<http://emailbydomain.com>

Auto manuals search

<http://auto.somanuals.com>

TV manuals search

<http://tv.somanuals.com>