

mellerware®

E X E C U T I V E

T r e n t o E s p r e s s o M a k e r

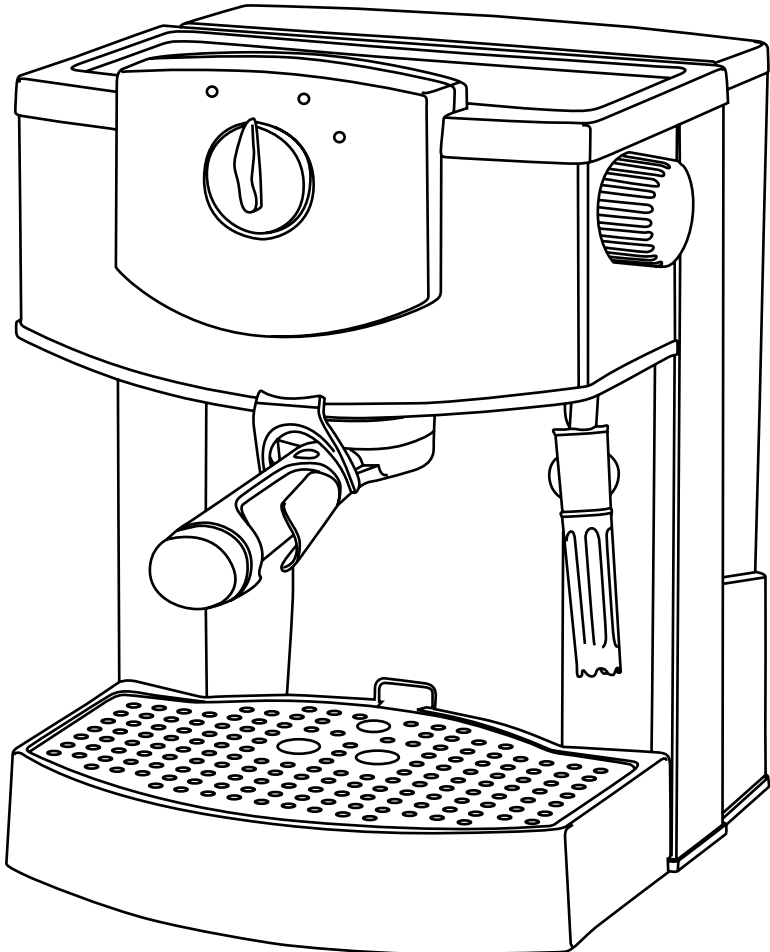

complies with
SABS
IEC60355
SAFETY STANDARDS



1200W

2 YEAR
GUARANTEE

Model:
29200

PLEASE READ ALL INSTRUCTIONS BEFORE USE

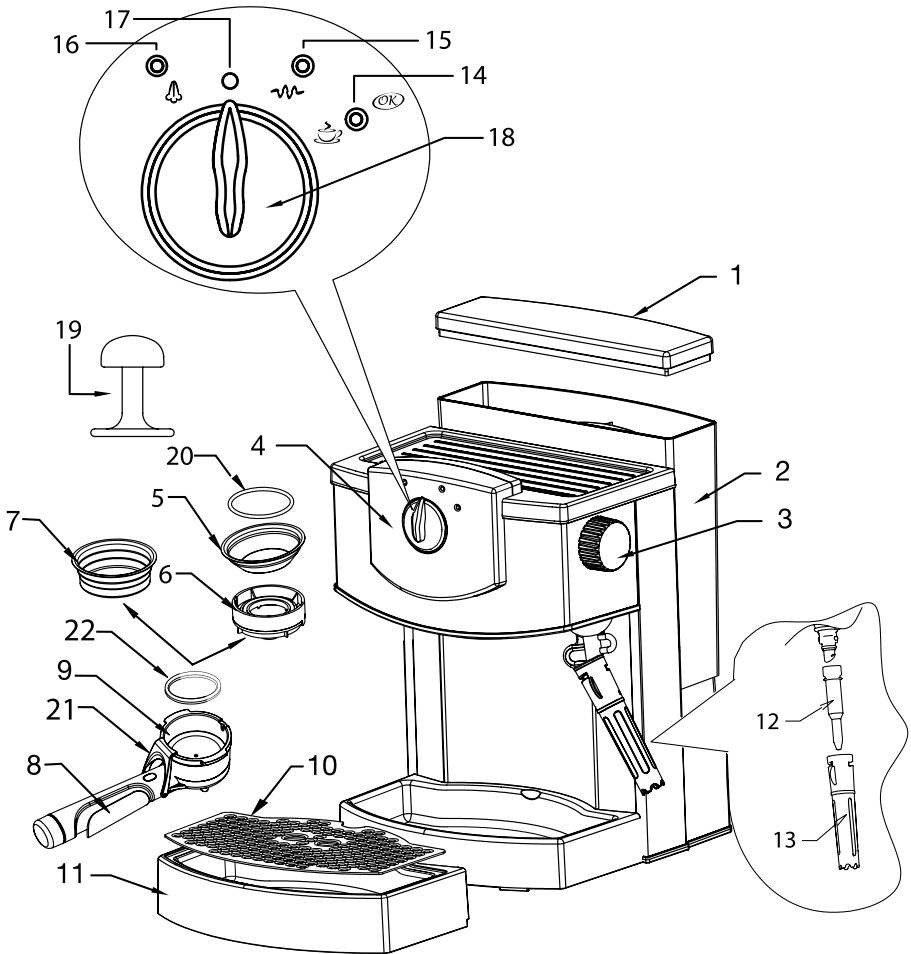
2 year guarantee



Description

- | | | |
|--------------------------------------|--------------------------------------|-----------------------------------|
| 1 Lid for water tank | 9 Filter holder | 17 "0" Off position |
| 2 Water tank | 10 Drip plate | 18 Selector switch |
| 3 Steam release knob | 11 Removable drip tray | 19 Coffee Tamper |
| 4 Control panel | 12 Steam inner tube | 20 Rubber ring for ESE coffee pod |
| 5 1-cup filter basket | 13 Steam outer tube | 21 Handle clip |
| 6 Pressure valve for 1 cup of coffee | 14 "OK" light / Brewing mode | 22 Sealing ring |
| 7 2-cup filter basket | 15 Heater light / Boiler on function | |
| 8 Pressure reducer paddle | 16 Cappuccino function | |

IMPORTANT SAFETY INSTRUCTIONS

When using electrical appliances, basic safety precautions should always be followed to reduce the risk of fire, electrical shock and personal injury.

- 1 Read all instructions carefully.
- 2 Do not touch hot surfaces. Use handles or knobs.
- 3 To protect against electrical shock, do not immerse cord, plug or unit in water or other liquid.
- 4 Close supervision is necessary when any appliance is used near children.
- 5 Unplug from outlet when not in use and before cleaning. Allow to cool before putting on or taking off parts and before cleaning the appliance.
- 6 If the supply cord is damaged; it must be replaced by the manufacturer or its service agent or a similarly qualified person in order to avoid a hazard.
- 7 The use of accessory attachments not recommended by manufacturer may cause hazards.
- 8 Do not use outdoors.
- 9 Do not let cord hang over edge of table or counter, or touch hot surfaces, including the stove.
- 10 Do not place on or near a hot gas or electric burner, or a heated oven.
- 11 To disconnect, turn power select switch to "0" (OFF), then remove plug from wall outlet.
- 12 This product is intended for household use only. Industrial or commercial use invalidates the warranty.
- 13 Do not operate the coffee brewing function and steaming function more than 1 minute at a time.

SAFETY WARNINGS

- This machine has been built to "make coffee" and to "reheat beverages"; please be careful to avoid burns from the sprays of hot water or steam and avoid any improper use.
- When the appliance is in use, do not touch any of the machine's hot surfaces.
- After unpacking, make sure that the machine is complete and undamaged. In case of doubt, do not use the appliance and seek the advice of a qualified service professional.
- Packaging materials (plastic bags, foam polystyrene, etc.) should not be left within reach of children as this could be a potential source of danger.

- This appliance is to be utilised for domestic use only. Any other use is to be considered improper and therefore dangerous.
- The manufacturer takes no responsibility for damage derived from improper use.
- Never touch the appliance with wet or damp hands.
- Never allow the appliance to be used by children or unfit persons.
- Children or unfit persons should not be allowed to use this product unsupervised.
- In case of breakdown or malfunctioning, turn off the appliance immediately and do not use it. For repairs, please contact a Service Centre authorised by the manufacturer and request the use of original replacement parts only. The lack of respect for this point may compromise the safe use of the appliance.
- The power supply cable of this appliance must never be replaced by the user, because it's replacement requires the use of special tools. If the cable should become damaged, or in case it needs to be replaced, please go to a Service centre authorised by the manufacturer.
- When the appliance is not in use, turn off and disconnect the plug from the socket.
- As with any electrical appliance, whilst the instructions aim to cover as many eventualities as possible, caution and common sense should be applied when operating your appliance, particularly in the vicinity of young children.



INSTALLATION

- Place the coffee maker on a flat work surface at a safe distance from taps and sinks.
- Check that the voltage corresponds to that indicated on the appliance rating plate. The appliance must always be connected to a well earthed socket rated at a 10A minimum. The manufacturer is not liable for damage caused by inadequate earthing of the appliance.
- In the event of incompatibility of the plug on the appliance and the socket, have the plug replaced by another of the right type by a qualified professional. If the cable is damaged or requires replacing, contact a Service Centre authorised by the manufacturer only.
- Never install the machine in an environment that can reach a temperature less than or equal to 0° C. (if the water in it freezes the coffee maker may be damaged.)



USING IT FOR THE FIRST TIME

- When first using this brewer, please carry out a cleaning procedure before it is pre-heated: fill the container with water to the level marked MAX, tighten the filter in place of brewer; turn the switch to brewing mode . At the same time, place an adequate container under the filter holder and make sure the two brewing spouts are over the container. Now, you can hear the motor of the pump rumbeling. Water may take a while to come out of the spout if you are using it for the first time, or if it has not been used for some time. The cleaning procedure is completed when half the water is left in the container. now you can proceed to the pre-heat procedure.

PRE-HEATING THE COFFEE MACHINE

- For the proper function as well as longer life in using the coffee brewer, remember to fill with water before the heater mode  of the boiler is turned on: by turning the selector switch to brewing mode , and wait until water drips out from the spout.
- For optimum pre-heating the selector switch can be left in the heater mode  for approximately half-an-hour before making any coffee, as long as the filter holder is firmly attached to the appliance (make sure the steam release knob is closed).
- To install the filter properly, simply hold the filter handle, flip handle clip backward and place it level under the heater. Align the filter holder so that the handle is pointing directly in front of the heater. Now rotate the handle from left to right until it is tight.

NOTE:

- * Although the optimum pre-heating time for the machine is 10 minutes when the selector is in the heater mode , the machine can be operated after two minutes once the OK light  is lit.
- * Fix the filter as tight as possible in the installation to avoid water leaking from the filter.

HOW TO PREPARE ESPRESSO COFFEE

FILLING THE WATER TANK:

- To remove the water tank simply pull upwards and fill the tank at the sink. Do not exceed the MAX level on the water tank. The tank may also be filled without removing it, simply by pouring water into it directly from a jug.

- Replace the tank by connecting the valve at the bottom of the tank with the hole in the base of the machine.

NOTE: Do not operate the appliance without water in the tank and always remember to fill the tank when the water level goes below the MIN level.

The brewing of espresso requires several attachment to be placed in the coffee filter. The general operations are described as below:

2-cups coffee (with ground coffee)

- Make sure the sealing ring has been placed in the filter holder before fitting the 2-cups filter basket;
- Fill in the filter basket with appropriate amount of ground coffee (12g recommended) and follow general brewing procedures.
- After brewing, grip the filter handle and pressure reducer firmly (hold for 5 seconds) when removing the filter holder, so that the pressure remaining in the filter will be release and the filter can be removed safely.

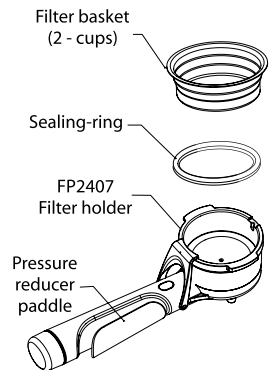

NOTE:

- * Please check if the sealing ring has been placed properly in the coffee filter before fitting in the coffee filter basket.
- * After brewing, remember to grip the pressure reducer together with the filter handle firmly when removing the filter so as to avoid the danger of accidental pressure release.
- * Every time after brewing, remember to clean your coffee filter for hygiene and for preventing the coffee grounds from blocking the hole of the reducer.

1-cup coffee (with ground coffee)

- Make sure the one cup pressure valve attachment has been placed in the filter holder before fitting in the one cup filter basket;
- Fill in the filter basket with appropriate amount of ground coffee (6g recommended) and follow general brewing procedures.
- After brewing, grip the filter handle and

pressure reducer firmly (hold for 5 seconds) when removing the filter holder, so that the pressure remaining in the filter will be released and the filter can be removed safely.

NOTE:

- * When placing the pressure valve attachments into the coffee filter, please check if the sealing ring has been fitted in the filter holder. Otherwise, it may fail to brew cappuccino because the filter has not been completely sealed.
- * After brewing, remember to grip the pressure reducer together with the filter handle firmly when removing the filter so as to avoid the danger of accidental pressure release.
- * Every time after brewing, remember to clean your coffee filter for hygiene and for preventing the coffee grounds from blocking the hole of the reducer.

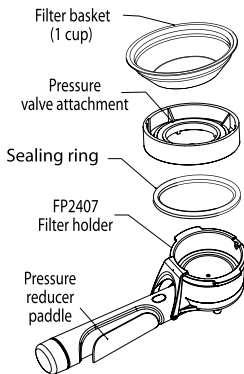

1-cup coffee (with ESE coffee pod)

- a. Make sure the 1-cup pressure valve attachment has been placed in the filter holder before fitting in the 1-cup filter basket;
- b. Fit in a ESE coffee pod to the filter and put the O-ring (for ESE POD) on top of it. Follow general brewing procedures.
- c. After brewing, grip the filter handle and pressure reducer firmly (hold for 5 seconds) when releasing the filter holder, so that the remaining pressure in the filter will be released and the filter can be removed safely.

NOTE:

- * When placing the pressure valve attachments into the coffee filter, please check if the sealing ring has been fitted in the filter holder. Otherwise, it may fail to brew Espresso because the filter has not been completely sealed.
- * When using ESE coffee pod, fit in

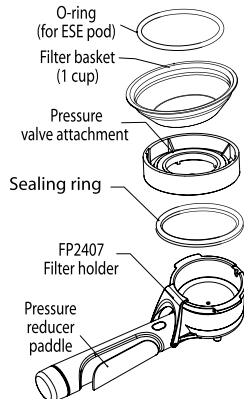

the o-ring after fitting in the ESE coffee pod. The ESE Coffee pod have to be purchased separately.

- * When placing the pressure valve attachments into the coffee filter, please check if the sealing ring has been fitted in the filter holder. Otherwise, it may fail to brew Espresso because the filter has not been completely sealed.

Do NOT unscrew and remove the filter basket from the machine immediately after brewing the coffee lest the coffee remains will spill out and stain your clothes or even burnt your skins. Leave for a while (around 5 minutes) before removing the filter holder is appropriate.

1. After preheating the coffee unit as described above, put a coffee cup under the filter and set the switch to the Brewing position ☺. At this point, hot water flows out from the coffee outlet of the filter. Turn the switch to the Heater position ~. again when the Ok light * is off. Empty the cup, and detach the filter.
2. Insert the filter basket to the filter holder. Then, put ground coffee into the filter holder and press it with the coffee tamper.

NOTE:

- * The manufacturer has provided two types of filter holder. The smaller one is for the one cup, recommend to hold 6g ground coffee for approximate 30ml espresso; the bigger one is for two cups, recommend to hold 12g ground coffee for approximate 60ml espresso.
- * Tamping the coffee gives a better quality espresso. If you press too hard, the coffee comes out slowly and the cr ma is dark in colour. If on the other hand, the coffee is not pressed enough, it will come out too quickly and the cr ma will be light in colour.
- * Remove any excess coffee from the filter holder rim and attach the filter holder to the machine.

NOTE: Tighten the filter handle to avoid leaks.





4. Place the pre-heated coffee cup underneath the filter holder, where coffee drips via the holes. Unless you need to make two cups of coffee at the same time.
5. When the Ok light (OK) is lit, you may turn the switch to the Brewing position ☺. At this point, espresso coffee flows into your cup continuously. Turn the switch to the Heater position ~ when there is enough coffee in your cup.
6. After brewing, turn the switch to OFF position and unplug the coffee maker from the electric socket.
7. After brewing, wait after the product is cool, grip the handle of the filter holder (together with the pressure reducer paddle) and turn the holder from right to left for removal simultaneously turning the clip of the handle

over to cover the filter basket firmly. Discard the coffee dregs from the filter basket with moderate force and then clean the filter basket and holder for future use.

NOTE:



- * During the brewing process, do not remove the filter holder from the coffee maker.
- * When pressing the reducer paddle on the handle the excess pressure in the filter holder will be released to revert accidental pressure release.

HOW TO BOIL HOT WATER

1. Mount the filter together with the empty filter holder (or without a filter holder) to the coffee unit as described above.
2. Turn the switch to the Heater position . Wait until the Ok light  is lit.
3. Put the cup under the two outlets of the filter to hold the hot water.
4. When the Ok light  is lit, turn the switch to the Brew position  when hot water will flow into the cup nonstop through the outlets of the filter till the Ok light is off, then turn the switch back to the Heater position. If you need more hot water repeat the above steps when the Ok light is lit again.
5. Turn the switch to the OFF position. Unplug the unit from the mains.

NOTE: Do not operate the appliance without water in the tank and always remember to fill the tank when the water level goes below the MIN level. Do not fill exceeding the MAX level on the water tank.

HOW TO PREPARE FROTHY MILK FOR CAPPUCCINO

1. Prepare Espresso following the above mentioned procedures. Prepare a cup and adequate milk.
- NOTE:** chill the milk in refrigerator before use. Do not use hot milk.
2. Turn the selector switch to Steam mode  and wait until the Ok light  is on. This machine will then automatically detect the required temperature. The Ok light will be on when temperature reaches appropriate level.

NOTE: Make sure the steam nozzle is closed when turning the selector switch to Steam mode.

3. Pour adequate cold milk into the cup.
4. Place the cup under the steam nozzle and make sure to bathe the end of steam nozzle into the milk completely.
5. Turn the steam release knob anticlockwise,

release the steam to make a layer of foam on the milk.

NOTE:

- * When the steam release knob is turned to "MAX", it can not go further but backwards.
 - * Do not force to turn the knob to avoid danger or injury caused by the flow of hot steam.
6. When adequate foam is made, turn the steam release knob clockwise and turn off the power of the machine.
 7. Pour adequate hot milk into coffee, a cup of hot coffee with milk is done.
 8. Unplug the machine from the socket.
 9. Let the machine to cool down, then hold the joint of steam nozzle with one hand, and detach the whole nozzle set with another, rinse the set then assemble back into the unit.

BREWING CAPPUCCINO

1. Prepare Espresso coffee, using large cups for Cappuccino (see "HOW TO PREPARE ESPRESSO COFFEE" paragraph).
2. Pour the frothed milk into the cups containing the Espresso coffee (see "HOW TO PREPARE HOT MILK FOR CAPPUCCINO" paragraph).
3. Add sugar to taste and, if desired, sprinkle a little powdered chocolate on top of the froth.

CLEANING AND MAINTENANCE CLEANING THE ESPRESSO BOILER OUTLET

At least twice a year, it is necessary to clean the outlet of the espresso boiler in the following manner: * Check that the coffee machine is not warm and the plug is detached from the mains; * Using a screwdriver, unscrew the screw that holds the outlet of the espresso boiler, Using a moist cloth, clean the area of the boiler where the outlet was positioned; . Using a moist cloth, clean the area of the boiler where the outlet was positioned; . Rinse the outlet under the tap, still scrubbing it; * Replace the outlet of the espresso boiler.

NOTE:

- * Do not use solvents or detergents in cleaning the coffee maker. Use a soft damp cloth.
- * Remove the drip-trays, empty them and wash them periodically.
- * During cleaning, never immerse the unit in water - it is an electrical appliance.

DESCALING

It is advisable to clean the calcium from the machine every 300 cups of coffee. During cleaning, it is possible to proceed as follows:

1. Fill the tank with water using 1 liter of water;

2. Dissolve 2 spoonfuls (about 30 grams) of citric acid in the water;
3. Turn the selector knob to the 'Heater' position and wait until the 'OK' light comes on.
4. Check that the filter holder is not attached and place a container under the outlet of the machine;
5. Turn the selector knob to the 'Brew' position and allow half of the solution in the tank to flow out, Then stop the flow by turning the selector to the "0" position.
6. Allow the solution to act for about 15 minutes, then start up the flow again until the tank is completely empty;
7. To eliminate the remains of the solution and the calcium, rinse the tank well, fill it with clean water and replace.
8. Turn the selector knob to the 'Brew' position and allow all of the remaining solution in the tank to flow out.
9. Turn the selector knob to the 'Heater' position and repeat operations 7 and 8 one more time.

TROUBLE SHOOTING GUIDE

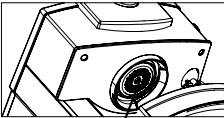
PROBLEM	POSSIBLE CAUSES	SOLUTION
<p>Espresso coffee no longer comes out.</p>  <p>Outlet of Espresso Boiler</p>	<ul style="list-style-type: none"> • Lack of water in the tank. • The holes in the filter holder spouts are blocked. • The outlet of the espresso boiler is blocked. • The tank is badly inserted and the valve at the bottom is not open • Air come into the "heater" 	<ul style="list-style-type: none"> • Fill the water tank • Clean the filter holder or filter basket and coffee pressure valve • Clean as indicated in the "Cleaning the espresso boiler outlet" section. • Press the tank lightly so as to open the valve at the bottom. • Open steam release knob for gas release (Put the empty cup under the steam outlet of the nozzle.)
<p>Espresso coffee drips from the edges of the filter holder, instead of from its holes.</p>	<ul style="list-style-type: none"> • The filter holder is badly inserted. • The holes in the filter holder spouts are blocked. • The plastic ring for the filter holder has not been fitted in or has come off. 	<ul style="list-style-type: none"> • Attach the filter holder on correctly and turn it all the way. • Clean the holes in the spouts • Fit in the plastic ring properly.
<p>The espresso coffee is cold.</p>	<ul style="list-style-type: none"> • The 'OK' pilot light was not on when the coffee delivery switch was pressed. • The preheating was not carried out. • The cups were not preheated. 	<ul style="list-style-type: none"> • Wait until the OK pilot light comes on. • Carry out the preheating as indicated in the "Preheating the coffee unit" section. • Preheat the cups by rinsing them in hot water.
<p>The pump is too noisy.</p>	<ul style="list-style-type: none"> • The water tank is empty. • The tank is inserted wrongly and the valve at the bottom is not open. 	<ul style="list-style-type: none"> • Fill the tank • Press the tank lightly so as to open the valve at the bottom.
<p>The coffee has an acidic taste.</p>	<ul style="list-style-type: none"> • The unit was not sufficiently rinsed after the descaling process procedure. 	<ul style="list-style-type: none"> • Rinse the unit as described in the "descaling" section.
<p>The coffee cream is light-coloured (the coffee comes out quickly from the spout).</p>	<ul style="list-style-type: none"> • The ground coffee has not been tampered enough. • The quantity of ground coffee is not enough. • The coffee is not ground finely enough. 	<ul style="list-style-type: none"> • Tamper the ground coffee down more. • Increase the quantity of coffee. • Only use coffee specifically ground.
<p>The coffee cream is dark (the coffee comes out slowly from the spout).</p>	<ul style="list-style-type: none"> • The ground coffee is too tightly pressed. • The quantity of ground coffee is too much. • The espresso boiler outlet is blocked. • The coffee is too finely ground. 	<ul style="list-style-type: none"> • Press the coffee less. • Decrease the quantity of ground coffee. • Clean the outlet as described in "Cleaning the espresso boiler outlet" section. • Only use coffee specifically ground for espresso coffee machines.
<p>The coffee is not creamy enough or not creamy at all.</p>	<ul style="list-style-type: none"> • The pressure valve has not been fitted in • The plastic ring for the pressure valve has not been fitted in or has come off 	<ul style="list-style-type: none"> • Fit in the pressure valve properly • Fit In the plastic ring properly
<p>The milk does not froth when making a cappuccino.</p>	<ul style="list-style-type: none"> • The milk is not cold enough. • The cappuccino maker is dirty. 	<ul style="list-style-type: none"> • Always use milk at refrigerator temperature • Carefully clean the pinholes in the milk frother.

creative housewares

18 Jig Avenue Montague Gardens Cape Town
PO. Box 37153 Chempet 7442 South Africa
Tel: +27 21 551 5760 Fax: +27 21 551 1189
Service Centre Share Call: 086 111 5006
web: www.creativehousewares.co.za

Free Manuals Download Website

<http://myh66.com>

<http://usermanuals.us>

<http://www.somanuals.com>

<http://www.4manuals.cc>

<http://www.manual-lib.com>

<http://www.404manual.com>

<http://www.luxmanual.com>

<http://aubethermostatmanual.com>

Golf course search by state

<http://golfingnear.com>

Email search by domain

<http://emailbydomain.com>

Auto manuals search

<http://auto.somanuals.com>

TV manuals search

<http://tv.somanuals.com>