

Operating Instructions

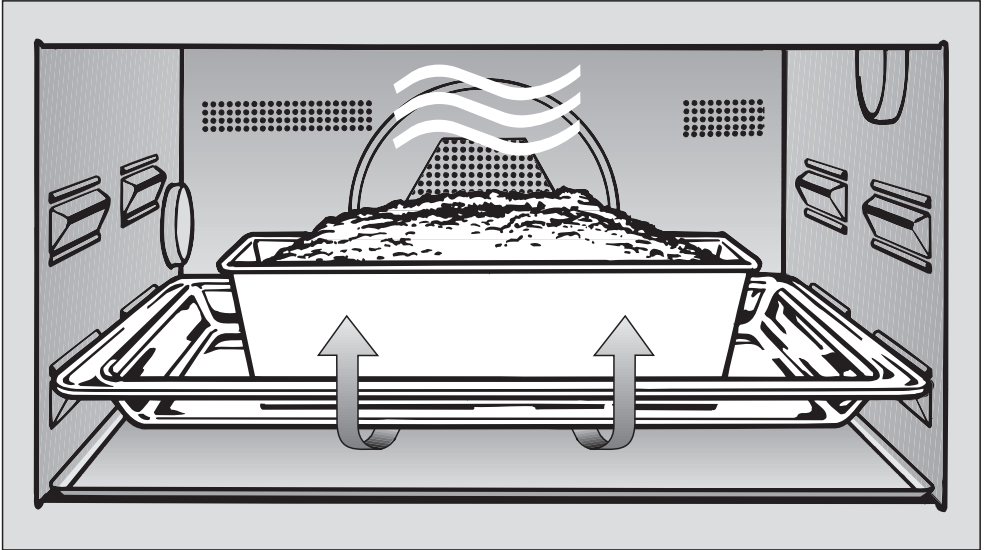

Microwave Combination Oven H 176 MB, H 177 MB H 186 MB, H 187 MB

It is **essential** to read these operating instructions before installing or using the machine, to avoid the risk of accident, or damage to the machine.



M.-Nr. 05 237 671

Description of the appliance

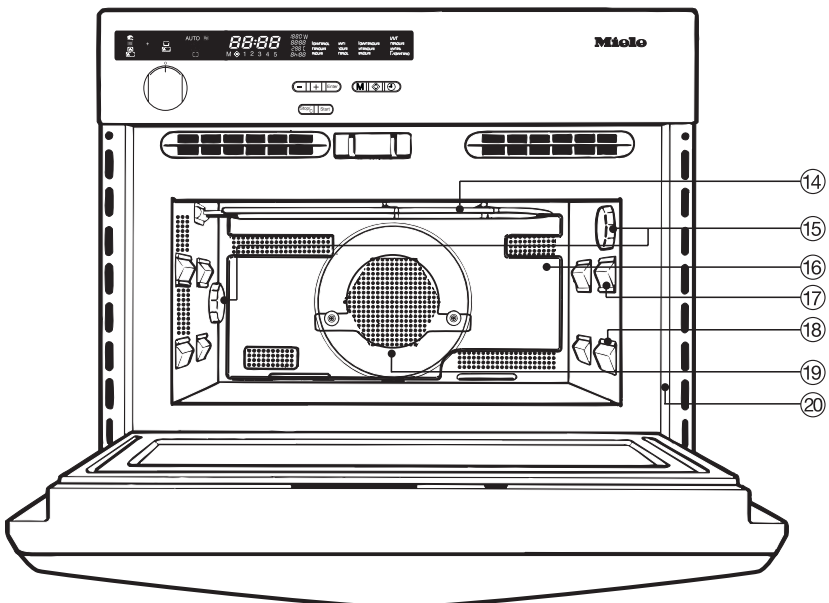
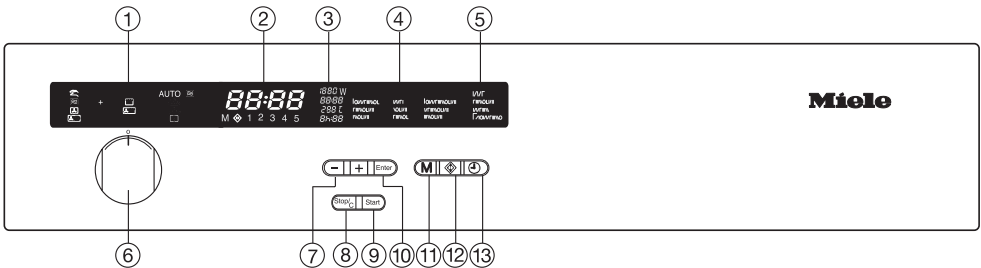
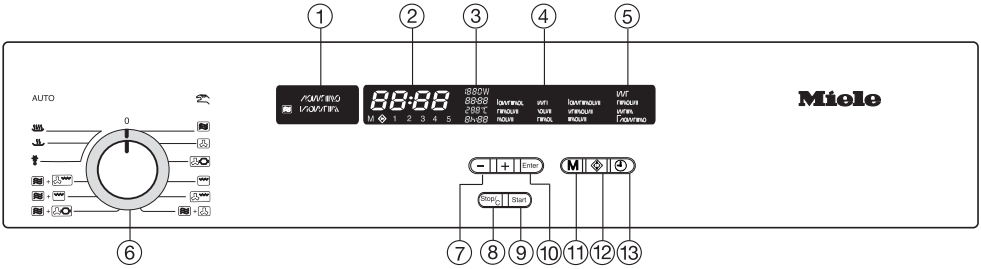

Description of the appliance

- ① Display field (according to model)
 - for operating modes
 - MANUAL / AUTOMATIC
- ② Data entry display
- ③ Selected settings display
- ④ Display for: - Food groups
- Automatic-Programmes -
- ⑤ Status display for the clock
- ⑥ Function selector
- ⑦ "- /+" Touch controls with indicator light for selecting a microwave setting or temperature, time, food group, weight
- ⑧ Touch control for interrupting, cancelling a cooking process
- ⑨ Touch control with indicator light for starting a cooking process
- ⑩ Enter touch control with indicator light for confirming selected setting
- ⑪ Touch control for memory function M
- ⑫ Touch control for the short step system \diamond
- ⑬ Touch control for entering times
- ⑭ Grill element
- ⑮ Oven interior lighting
- ⑯ Removable glass rear panel
- ⑰ Second shelf support
- ⑱ First shelf support
- ⑲ Air vent for the fan
- ⑳ Data plate

Accessories

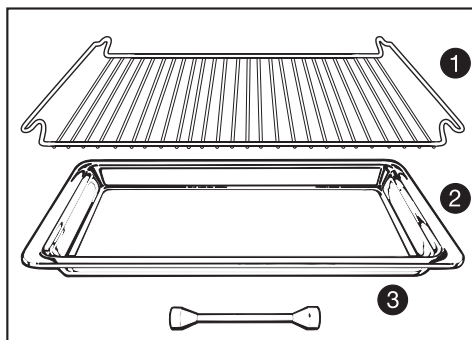

- ① Rack, ② Glass tray, ③ Boiling rod



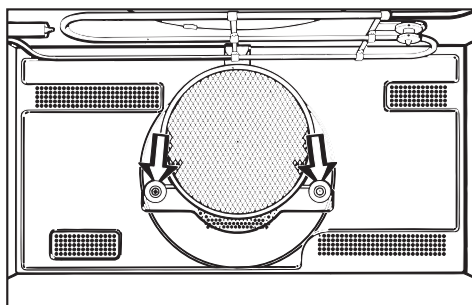

Grease filter



Remember to insert the grease filter when roasting on the rack using the Fan Heat (hot air), Auto Roast and Fan Grill systems - both solo and in combination with the microwave.









The grease filter will trap any excess droplets of fat keeping the oven interior and the area behind the rear wall cleaner.

Contents

Description of the appliance	2
Accessories	3
Description of the functions	7
Functions	7
Safety features	8
Energy saving functions	8
Warning and Safety instructions	9
Caring for the environment	15
Before using for the first time	16
Operating modes	17
Microwave 	17
Traditional oven functions	18
Fan Heat 	18
Auto Roast 	18
Grill 	18
Fan Grill 	18
Combination programmes	19
Automatic programmes	19
Suitable containers for microwave ovens	20
Material and shape	20
Operation - Controls	25
Function selector	25
Touch controls	25
Time of day	27
Setting time of day (24 hour clock)	27
Turning off the time of day display	27
Showing time of day display again	27
Notes on use	28
Selecting a function	28
Selecting a microwave power level / temperature	28
Entering the time	29
Operating modes	30
Combination programmes	31
Automatic programmes	33
Altering entered data	36
Before starting a process	36
After starting a process	36

Memory function	38
Short step system	39
Automatic delay start	41
Opening the door	42
When the time has elapsed	43
Audible tone	43
Starting another process	43
When a process has finished	43
Minute Minder	44
Altering a minute minder entry	44
When the minute minder time has elapsed	44
Energy saving functions	45
"Night time dimming"	45
Switching off the oven interior lighting	46
Programming lock	47
Defrosting	48
Chart for defrosting food	49
Reheating	50
Chart for reheating food	52
Cooking	53
Microwave 	53
Fan Heat 	54
Combination programmes	54
Chart for cooking food	55
Chart for cooking and crisping/browning food	56
Defrosting and Re-heating / Cooking	57
Chart for defrosting and reheating or cooking of deep frozen ready made meals	58
Defrosting and reheating, or cooking and crisping or browning of deep frozen ready made meals	59
Grilling	60
Preparation of meat or fish	60
Test to see if cooked	60
Chart for grilling	61

Contents

Roasting	62
Auto Roast 	62
Microwave + Auto Roast  + 	63
After the roasting process is finished	63
Useful hints	63
Roasting in a covered pot	63
Roasting deep frozen meat	63
Chart for roasting	64
Baking	65
Fan Heat 	65
Microwave + Fan Heat  + 	65
Chart for baking	67
Cleaning and care	68
Appliance front and control panel	68
Oven interior	70
Glass back panel	70
Oven interior roof	71
Door interior	71
Accessories	71
Grease filter	71
Rack	71
Glass tray	71
Problem solving guide	72
After sales service	76
Customer contact	76
Electrical connection IRL, U.K., ZA	77
Electrical connection AUS, NZ	79
Installation	80
Possibilities for installation and combination	80
Installation measurements	80

Functions

User responsive

The appliance is designed to be "user responsive". When the user presses a function control the relevant display and indicator light will automatically light up.

* See "Operating modes" for further details.

"Solo" functions *

Each of the following functions can be used by itself "Solo":

- Microwave 

For defrosting, reheating and cooking food in a short time.

- Fan Heat (hot air) 

For baking, cooking food using hot air circulation.

- Auto Roast 

For automatic browning and continued cooking.

- Grill 

For browning and grilling flat food. Grill with the door shut.



- Fan Grill 

For grilling thick cuts, e.g. rolled meat, poultry. Grill with the door shut.

Combination programmes *

For combining the microwave with a traditional oven function.

Automatic programmes *

For cooking , reheating , and defrosting  selected food groups using the microwave.

Memory function

For storing up to 5 stages of a cooking process in memory, e.g. for initial and continued cooking.

Short step system

For storing in memory the microwave power setting and the time for cooking processes you use frequently.

Automatic delay start

For delaying the start of a process by up to 23 hours and 59 minutes.

Minute minder

For monitoring other kitchen activities, e.g. boiling an egg on a hob.

Time of day display

When the appliance is switched off the time of day is shown in the digital display. You can also turn off this display.

Description of the functions

Safety features

Door lock

Once a cooking process using the microwave has begun, the door will remain locked until the end of the programme.

You can cancel the door lock by pressing the Stop/C touch control. The programme will then be interrupted.

Programming lock

The programming lock prevents functions being entered unintentionally.

Safety cut-out

A process using a traditional oven function can be started without programming in a time. To prevent over-use and the consequent danger of fire, the appliance switches off automatically after a certain length of time. This can be between 1 hour and 10 hours depending on the function and temperature chosen.

If the microwave is switched off in between using two microwave cooking processes, there will be a delay of about 30 seconds before the new setting is accepted. Therefore wait a short while before starting the second process.

Energy saving functions

Door contact switch

If the door is opened during a programme using a traditional oven function (with or without microwave), a contact switch for the door switches the fan and heating element off automatically. The programme will continue to run again as soon as the door is shut. If 'Stop/C' was pressed before opening the door, then 'Start' must be pressed for the programme to continue.

Making use of residual heat

With the Fan Heat (hot air) and Auto Roast systems the heating shuts off automatically with the door closed when the current ambient temperature is sufficient to finish cooking the food. Whenever heat is lost, e.g. if the door is opened, the heating will switch on again automatically.

"Night time dimming" option

You can programme the appliance so that the brightness of the display is dimmed between the hours of 10 pm and 6 am. (22.00 to 6.00 hours).

Optional oven interior lighting

You can turn off the oven interior lighting if you do not want it to remain on during the entire cooking process. It will then only light up for approx. 10 seconds after you have pressed the Enter touch control.

Warning and Safety instructions

This appliance complies with all relevant legal safety requirements. Improper use of the appliance can, however, present a risk of both personal injury and material damage.

Before installation and before using the appliance for the first time, read the operating instructions carefully. They contain important notes on installation, safety, operation and care of the appliance. This way you will avoid the risk of accidents and damage to the appliance.

Keep these instructions in a safe place and pass them on to any future user.

Correct usage

The appliance is intended for domestic use only: to cook food, and in particular to defrost, reheat, cook, bake, roast and to grill. Any other usage is at the owner's risk and could be dangerous. The manufacturer cannot be held responsible for damage caused by improper use of the appliance.

Do not let children access the appliance or its controls. Supervise its use by the elderly or infirm.

If allowing older children to use the appliance without supervision please ensure that they are aware of how a microwave oven works and understand the dangers of improper use.

Technical safety

If the connection cable is damaged the new cable must be fitted by a Miele approved service technician.

Do not use the microwave function of the appliance if

- the door is warped.

- the door hinges are loose.

- holes or cracks are visible in the casing, the door, the door seal or the oven interior walls. Operating the appliance with this type of damage will result in microwave leakage, and present a hazard to the user.

Never open the casing of the appliance. Tampering with electrical connections or components and mechanical parts is highly dangerous to the user and can cause operational faults or electric shock.

Before connecting the appliance to the mains supply make sure that the rating on the data plate corresponds to the voltage and frequency of the household supply. It is essential that these data correspond as otherwise damage will occur to the machine. If in doubt consult a suitably qualified electrician.

Do not connect the appliance to the mains electricity supply by an extension lead. Extension leads do not guarantee the required safety of the appliance, (for example danger of overheating).

Warning and Safety instructions

■ The electrical safety of this appliance can only be guaranteed when continuity is complete between the appliance and an effective earthing system, which complies with local and national regulations. It is most important that this basic safety requirement is tested by a qualified electrician. The manufacturer cannot be held responsible for the consequences of an inadequate earthing system, such as an electric shock.

■ This appliance must only be operated as a built-in appliance. This is necessary to ensure that all electrical components are shielded.

■ Installation work and repairs may only be carried out by a suitably qualified and competent service technician approved by Miele in accordance with local and national safety regulations. Repairs and other work by unqualified persons could be dangerous. The manufacturer cannot be held responsible for unauthorised work.

■ This equipment is not designed for maritime use or for use in mobile installations such as caravans, aircraft etc. However it may be suitable for such usage subject to a risk assessment of the installation being carried out by a suitably qualified engineer.

■ The appliance is only completely isolated from the electricity supply when:

- it is switched off at the wall socket, and the plug removed (where applicable). Do not pull on the cable, only on the plug.
- or the mains fuse is withdrawn
- or the screw-out fuse is removed (in countries where this is applicable)

Ensure that current is not supplied to the appliance while maintenance or repair work is being carried out.

Use

General notes

■ Always ensure that food is sufficiently cooked or reheated. Many factors will affect the overall cooking time, including the size and amount of food, its initial temperature, changes to recipe and the shape and size of cooking container. Some foods may contain micro organisms which are only destroyed by thorough cooking, therefore when cooking or reheating foods, e.g. poultry, it is particularly important that food is fully cooked through (at over 70°C, for a minimum of 10 minutes). If in doubt select a longer cooking or reheating time.

■ It is important that the heat is allowed to spread evenly throughout the food being cooked. This can be achieved by stirring and/or turning the food, and by observing a sufficiently long standing time, which should be added to the time needed for cooking, reheating or defrosting.

Warning and Safety instructions

Always remember that cooking times in a microwave oven are usually considerably shorter than with traditional methods of food preparation. Excessively long cooking times can lead to food drying out and eventually burning, or could even cause it to catch fire.

There is also a danger of fire if breadcrumbs, flowers, herbs, grains etc., are dried in the microwave oven. Always ensure that this type of procedure is supervised.

Exercise caution when cooking or reheating food with a high sugar content, e.g. Christmas pudding. If heated for too long the sugar may caramelize or ignite.

Do not use full power if you warm empty dishes or dry herbs. The lack of minimum amount of food could cause damage to the appliance.

Do not leave the oven unattended when cooking with oils and fats as these can be a fire hazard if allowed to overheat.

If smoke occurs in the oven, to avoid fuelling any flame do not open the oven door. Turn the function selector to "0", or switch off at the mains and remove the plug from the socket. Do not open the oven door until the smoke has dispersed.

Never heat undiluted alcohol in the microwave oven as this can easily ignite.

Do not heat up unopened tins of food in the oven as pressure will build up in the tin and it can explode. This could result in injury or damage.

Food left in the oven to take advantage of residual heat should always be covered to avoid it drying out, and to avoid a possible build-up of condensation which could adversely affect the oven interior.

Try to avoid the interior walls being splashed with food or liquids containing salt. If it does happen wipe these away thoroughly, to avoid corrosion on the stainless steel surface.

Wear oven gloves when removing the glass tray from the oven. If the glass tray has a heavy load, pull it only slightly towards you, and then hold firmly at the sides as you take it out.

The glass dish and the rack take a maximum load of 8 kg. Do not exceed this or the accessories may be damaged.

Do not lean or sit on the open oven door. This could damage the appliance. Take care in the region of the hinges. An oven door can support a maximum load of 8 kg.

When it is hot do not place the glass tray on a cold surface, such as a tile or granite worktop. It could break. Place it on a pot rest or a wire rack.

Warning and Safety instructions

Under no circumstances use a steam cleaner to clean this appliance. The steam could attack the electrical components and cause a short circuit, or permanent damage to the surface and to components, for which the manufacturer of the oven cannot accept any responsibility.

Do not use the oven to heat up the room. Due to the high temperatures radiated, objects left near the oven could catch fire.

When using kitchen appliances connected to sockets near the oven ensure that the cable cannot get trapped in a hot oven door, which could melt the cable insulation and be dangerous.

In countries which may be subject to infestation by cockroaches or other vermin, pay particular attention to keeping the appliance and its surroundings in a clean condition at all times.

Any damage which might be caused by cockroaches or other vermin will not be covered by the appliance guarantee.

Microwave function

Before serving remember to allow sufficient standing time and then always check the temperature of the actual food itself after taking it out of the oven. Do not be misled by the temperature of the container which does not necessarily give a correct indication of the temperature of the food or liquid in it. **This is particularly important when preparing food for babies, children, and the elderly or infirm.**

Never cook or reheat food or liquids in sealed containers or bottles. With baby bottles the screw top **and** teat must be removed. Otherwise pressure builds up which can cause the bottle or container to explode posing a severe risk of injury.

When heating liquids, the boiling rod provided should be placed into the container.

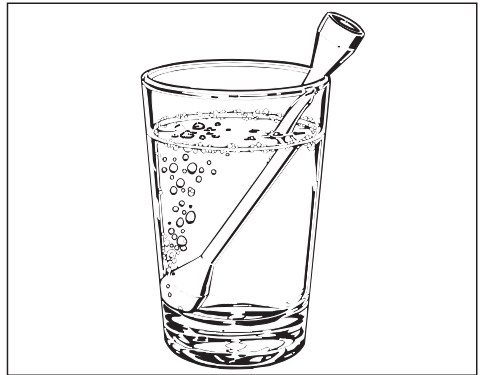

When heating liquids, milk, sauces etc., in the oven without the boiling rod, the boiling point of the liquid may be reached without the production of typical bubbles. The liquid does not boil evenly throughout. This so-called 'boiling delay' can cause a sudden build up of bubbles, when the container is removed from the oven or shaken. This can lead to the liquid boiling over suddenly and explosively. There is a danger of burning. The formation of bubbles can be so strong that the pressure forces the oven door open. The user could be injured and the appliance damaged.

The boiling rod ensures that the liquid boils evenly and that bubbles form at an early stage during the operation.

Warning and Safety instructions

Do not use any containers or cutlery made from or containing metal, aluminium foil, lead crystal glassware, temperature-sensitive plastics, wooden utensils or cutlery, metal clips or wire ties. Such items could be damaged, or cause a fire hazard.

The rack supplied with the appliance is designed to be compatible with microwaves, and can therefore be used with or without the microwave function.

The rack gets hot when operating either the microwave function or the browning element, or both. There is a danger of burning.

Eggs can only be cooked in their shells in the microwave oven in a specially designed egg-boiling device. Similarly, hard-boiled eggs should not be reheated in the microwave oven as this may lead to the eggs bursting, even once they have been removed from the oven.

Eggs can be cooked without their shells in the microwave oven only if the yolk membrane has been punctured several times first. The pressure would otherwise cause the egg yolk to explode.

Do not reheat food in the oven in heat-retaining bags intended for normal ovens. These heat-retaining bags usually contain a thin layer of aluminium foil which reflects microwaves. This reflected energy can, in turn, cause the outer paper covering to become so hot that it ignites.

Food with a thick skin or peel, such as tomatoes, sausages, jacket potatoes, aubergines, should be pierced or cut in several places to allow steam to escape and prevent the food from bursting.

Ovenproof earthenware can retain a considerable amount of moisture. Earthenware and porcelain containers with hollow handles and lid knobs must only be used in this oven if they have vent holes, which allow the moisture to escape. Without vent holes there can be a pressure build-up, causing the container to crack or shatter, with the danger of injury.

Traditional oven functions: Fan Heat, Auto Roast, Grill, Fan Grill

Caution - Danger of burning
When the oven is being used as a traditional oven it can get very hot.

Great care should be taken to ensure that small children do not touch the oven when it is being used. External parts of the oven such as door glass, handle vents and the fascia panel can become quite hot.

Wearing heat-resistant oven gloves is recommended when placing food in the oven, turning or removing it. When the Grill or Fan Grill function has been chosen, either solo or in a combination programme the grill element becomes very hot and there is a danger of burning.

Warning and Safety instructions

■ Wait until the grill element has cooled down before lowering it for cleaning.

■ Do not use force to pull it down as this can cause the element to break.

Bottling

Bottling should only be undertaken by an experienced cook who has received proper training in this method of preserving fruit and vegetables in an oven or microwave oven, and understands the implications of the chemical reactions involved.

The manufacturer cannot be held liable for damage caused by non-compliance with these Warning and safety instructions.

Disposal of the packing material

The transport and protective packing has been selected from materials which are environmentally friendly for disposal and can normally be recycled.

Ensure that any plastic wrappings, bags etc. are disposed of safely and kept out of the reach of babies and young children. Danger of suffocation!

Rather than just throwing these materials away, please ensure they are offered for recycling.

Disposal of your old appliance

Old appliances may contain materials which can be reclaimed or recycled. Please contact your dealer, your local waste collection centre or scrap merchant about potential recycling schemes.

■ Before discarding an old appliance switch off and disconnect it from the power supply. This should be done by a competent person. Cut off the cable directly behind the appliance to prevent misuse. Cut off and render any plug useless.

Ensure that the appliance presents no danger to children while being stored for disposal.

Before using for the first time

- Wipe out the oven interior with hot water and a little washing up liquid. Dry using a soft cloth.

Do not shut the oven door until the interior is completely dry, to avoid odours and the possibility of corrosion developing.

- Wash the accessories.

With new appliances there is usually a smell during the first use. It is dispelled more quickly by using a high temperature as follows:

Run the oven on the Fan Heat  setting for at least an hour.

- Select Fan Heat  with the function selector.

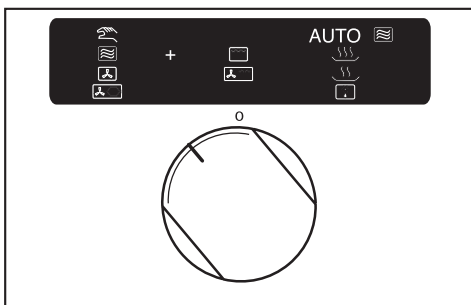
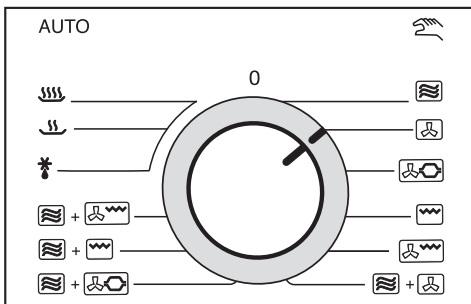

- Enter the highest possible temperature with the "+" touch control.



- Confirm by pressing Enter.



- Enter a time (at least 1 hour) with the "+" touch control.



- Press the Start touch control.

Ensure the room is well ventilated during this process.

Microwave

Microwave cooking offers the benefits of speed, convenience and nutritional advantages when food does not require browning or crisping.

Functional description

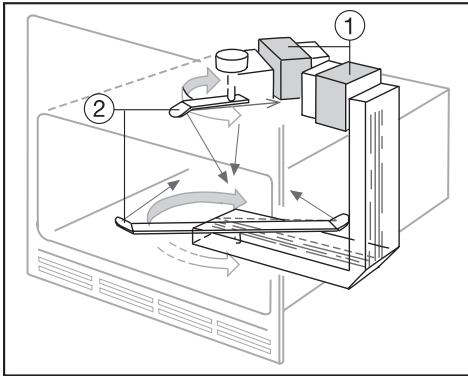

This oven is equipped with two magnetrons ①, which convert electrical energy into microwaves.

There are two stirrer fans ②, one above the oven ceiling and the other under the oven floor. The fans distribute the microwaves evenly throughout the oven interior, rebounding them off the walls so that they reach and enter the food from all sides.

An advantage of this system is that food can be cooked on two levels simultaneously, (e.g. on the oven floor and the second runner level).

In order for microwaves to reach the food, they must be able to penetrate the cooking utensil being used.

Microwaves can penetrate porcelain, glass, cardboard and plastics but not metal. Do not, therefore, use utensils made of metal, or which contain metal, for example in the form of gold or silver trim. The metal reflects the microwaves and this could lead to the creation of sparks. The microwaves cannot be absorbed.

All food contains moisture molecules which, when subjected to microwave energy, start to oscillate 2.5 thousand million times a second. The friction caused by this vibration creates heat, which first starts developing around the outside of the food and then slowly penetrates towards the centre. The moisture, fat and sugar content of food will affect the speed at which it is cooked.

As heat is produced directly in the food,

- food can generally be cooked without adding much liquid or cooking oil
- cooking, reheating and defrosting in a microwave oven is quicker than using traditional oven methods
- nutrients, such as vitamins and minerals, are generally retained
- colour, texture and taste of food are not impaired
- the surface temperature stays cool enough to avoid browning.

Operating modes

Traditional oven functions

Fan Heat 

Auto Roast 

Grill 

Fan Grill 

These cook and brown the food.

Fan Heat

The fan circulates heat constantly around the oven, giving a very even temperature throughout.

It sucks in the air, heats it over a ring element and blows it back through the carefully spaced openings in the back panel.

As the heat is quickly transferred to the food, it is not usually necessary to pre-heat the oven, except when roasting sirloin or fillet or for foods such as puff pastry and yeast mixtures which require instant heat.

With Fan Heat food can be baked or roasted on the floor and the second level at the same time.

Auto Roast

After the selected temperature is entered, the oven heats initially to a preset high temperature which seals the meat to keep it succulent and tasty. The oven temperature is then automatically returned to the temperature setting selected.

When roasting, you are strongly recommended to cover the food. Not only does this help retain all the juices, but will also make cleaning the oven easier afterwards.









Grill

As the grill element needs to radiate a high heat in order to cook the food, it will take several minutes after being switched on for the element to glow red hot and so produce sufficient infra-red heat for grilling. Pre-heat the grill with the oven door closed for approx. 5 minutes before starting to cook.

Fan Grill

The hot air from the grill is distributed by the fan in the rear of the oven evenly over all the food being grilled. This enables a lower temperature to be selected than for normal oven grilling.



Combination programmes

-  +  Microwave + Fan Heat
-  +  Microwave + Auto Roast
-  +  Microwave + Grill
-  +  Microwave + Fan Grill

The combination programmes enable the grill, fan and Auto roast settings to be used in conjunction the the microwave facility.

In general when using the combination programmes, you should not set the microwave power level higher than 150 W for baking, and not higher than 450 W for cooking, roasting and grilling.

Automatic programmes

-  Cooking
-  Reheating
-  Defrosting

The microwave's automatic programmes can be used to cook, re-heat or defrost food.

They are dependent on weight, i.e. after selecting the appropriate food group, you then enter the weight of the food and the microwave power setting and time will be calculated automatically.

Suitable containers for microwave ovens

Microwaves

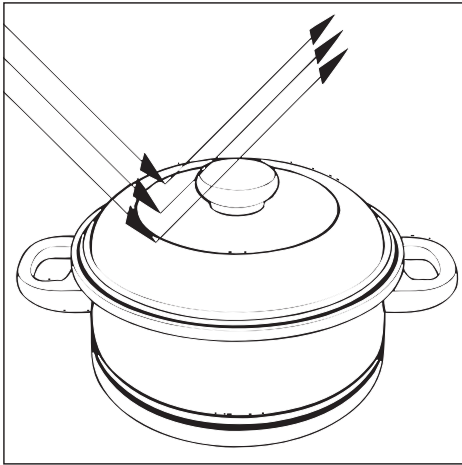

- are reflected by metal,

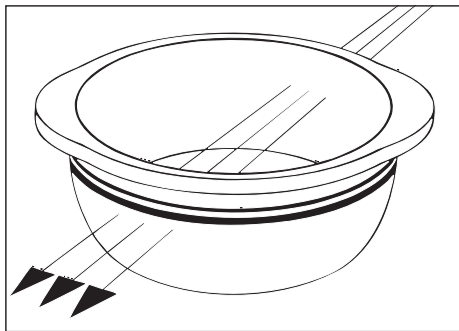

- pass through glass, chinaware, plastic and card,

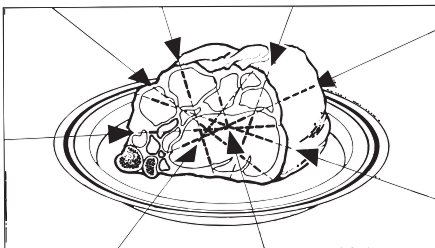

- and are absorbed by food.

Material and shape

The material and shape of containers used affect cooking results and times. Heat distribution is more even in round and oval shaped dishes than in rectangular containers, providing better results.

Metal

Metal containers, aluminium foil and metal cutlery, or china with metallic decoration such as gold rims or cobalt blue must not be used in microwave mode.

The metal reflects the microwaves, hindering the cooking process.

Exceptions:

If recommended by the producer, pre-cooked meals packed in aluminium foil containers can be defrosted and reheated in the microwave oven. Important: remove the lid first. However, as food is only heated from the top, it is better to remove the food from the aluminium foil container and transfer it to a dish suitable for a microwave oven. The heat distribution will be more even. If sparks and arcing occur when using a metal container, stop and transfer the food to a microwave safe container.

For even defrosting and to avoid overcooking unevenly shaped cuts of meat, poultry or fish, small pieces of aluminium foil may be used to mask wing-tips or other thin parts for the last few minutes of the process.

Suitable containers for microwave ovens

Make sure that the aluminium foil is at least 2 cm from the oven walls at all times. It must not touch the walls.

Metal meat skewers or clamps should only be used if they are very small in comparison to the size of the cut of meat.

The **rack** supplied with the appliance is suitable for use in a microwave oven. Do not place the rack on the oven floor.

The rack can get hot.

Glassware

Heat-resistant glass or ceramic glass are ideal for use in the microwave oven.

Crystal glass contains lead which could cause the glass to crack. Glass dishes with a milled rim are subject to the same risk. Both are unsuitable.

Earthenware

Although some ovenproof earthenware can be used in a microwave oven it may contain a considerable amount of moisture, causing it to become hot during use. It is normally advisable to avoid using it in a microwave oven.

Earthenware containers with hollow handles and lid knobs must only be used in this oven if they have vent holes, which allow the moisture to escape. Without vent holes there can be a pressure build-up, causing the container to crack or shatter, with the danger of injury.

Decorated earthenware is only suitable if the decoration is beneath an all-over glaze.

Earthenware can get very hot, and may crack.

Porcelain (chinaware)

Porcelain is suitable, however containers with hollow handles and lid knobs must only be used in this oven if they have vent holes, which allow the moisture to escape. Without vent holes there can be a pressure build-up, causing the container to crack or shatter, with the danger of injury.

Do not use porcelain with gold or silver edging or items with hollow knobs or handles as insufficient ventilation may cause pressure.

Glazes and colours

Some glazes and colours contain metal.

This makes them unsuitable for use in a microwave oven.

Plastics

Plastic containers must only be used for Microwave mode alone and not in conventional oven mode.

Plastics must be heat-resistant to a minimum of 180 °C. Otherwise the plastic may melt and fuse with the food.

Suitable containers for microwave ovens

Special plastic utensils, designed for use in microwave ovens are available from good retail outlets. Melamine ware is not suitable as it absorbs energy and heats up. When purchasing plasticware, make sure that it is suitable for use in a microwave oven.

Disposable containers, such as trays made from polystyrene, can only be used for very short timed warming and reheating of food.

Plastic boiling bags can be used for cooking and reheating. To reduce the risk of the bag bursting, they should be pierced first so that steam can escape and prevent a build-up of pressure.

Roasting bags and -tubes

Roasting tubes should be about 40 cm longer and roasting bags about 20 cm longer than the food being roasted, and carefully tied with string. Turn the ends over and secure them. Holes should be made according to the manufacturer's instructions.

Do not use metal clips or wire ties, even if bound by paper. There is a danger that they will ignite when heated.

Wood

Wooden dishes are not suitable.

Moisture contained in the wood evaporates when exposed to microwave energy, causing the wood to dry and crack.

Disposable containers

Only those plastic disposable containers which are specified by the manufacturer as suitable for use in a microwave oven may be used.

Do not leave the oven unattended when reheating or cooking food in disposable containers made of plastic paper or other inflammable material.

Disposable containers are not always recyclable or degradable.

Testing dishes for their suitability

If in doubt as to whether glass, earthenware or porcelain plates or dishes are suitable for use in a microwave oven, a simple test can be performed:

- Place the item you wish to test in the centre of the oven, fill a suitable glass with water and also place this in the oven.
- Shut the door.
- Select Microwave  with the function selector.



- Select the highest microwave power setting (1200 W) with the "+" control.

Suitable containers for microwave ovens



- Confirm by pressing "Enter".



- Enter a time of 30 seconds with the "+" control.



- Press the Start control.

If a crackling noise is heard accompanied by sparks during the test, switch off the appliance immediately. Turn the function selector to the "0" position.

Any crockery which causes this reaction, is unsuitable for use in the microwave oven.

The water in the glass should be warm, but the dish cool. If the dish is very hot and the water is cold, it would be unwise to use the dish.

If any doubt exists about the suitability of containers, please contact the supplier.

This test cannot be used to check whether items with hollow knobs or handles are suitable for use in a microwave oven.

A cover

- prevents too much steam escaping, especially when cooking food which needs longer to cook, such as potatoes,
- shortens and evens out the cooking process,
- prevents food from drying out,
- prevents any loss of aroma.

Always use lids or covers made of microwave-safe glass or plastic, or use a clingfilm recommended for use in a microwave oven, (pierce as instructed by the manufacturer). Unsuitable clingfilm can melt into the food.

Suitable containers for microwave ovens

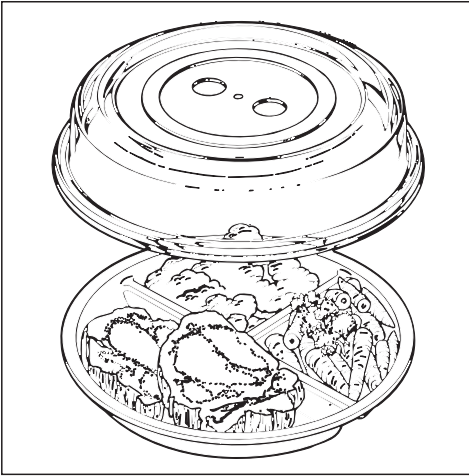

Sealed glass containers, such as jars of food, must be opened before they are placed in the oven.

Do not use a cover if

- cooking meals which are to be given a crisp finish,
- cooking breaded or battered foods
- using a combination programme.

The function selector and the touch controls are used to operate the appliance.

Function selector

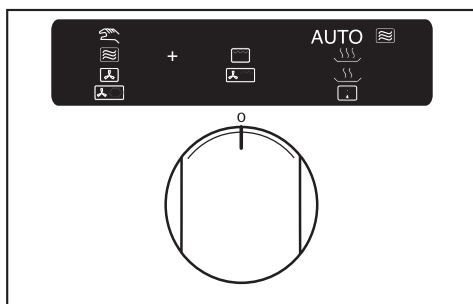
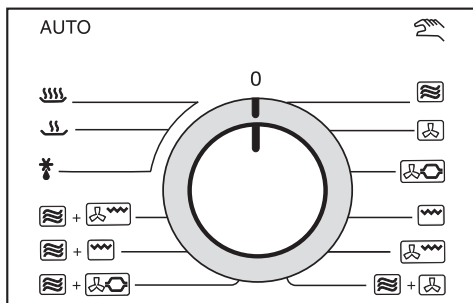

The function selector can be turned clockwise and anti-clockwise.

"Solo" programmes:

- Microwave
- Fan Heat
- Auto Roast
- Grill
- Fan Grill

Combination programmes:

- Microwave + Fan Heat
- Microwave + Auto Roast
- Microwave + Grill
- Microwave + Fan Grill

Automatic programmes:

- Cooking
- Reheating
- Defrosting

If the function selector is turned away from "0", the cool air fan will run at a very low level and the oven interior lighting will be switched on.

Exception: If a delayed start time has been programmed, the cool air fan and oven lighting will remain switched off until the programmed start time. The oven lighting can be switched on for approx. 10 secs. by pressing the "Enter" touch control.

Touch controls



- to confirm an entry or alteration.

The setting is accepted by the system and appears in the display.



- to start a process.

The Start touch control can only be used when the appliance door is shut.



- to interrupt a process which has already started,

- to delete a setting which has been selected,

- to cancel the door locking function (a microwave feature).

Operation - Controls



- to select a microwave power setting,
- to enter or alter the temperature or time step by step (press the control for a brief moment several times) or quickly (press and hold the touch control),
- to select a food group and to enter a weight (Automatic programme),
- to activate or cancel the programme lock ("- touch control).

Those touch controls which have indicator lights can only be confirmed if the relevant indicator lights are illuminated. If the indicator light does not light up then the touch control is locked.

Exception: The programme lock is activated by pressing the "-" touch control when the indicator light is not illuminated.



- to store various stages of a microwave cooking process in memory.



- to store frequently used microwave processes in memory,
- to call up the stored processes.



- to activate the minute minder,
- to enter, correct and turn off the time of day,
- to enable a delayed start.

After the appliance has been connected to the power supply or after a power cut "12:00" will appear in the display. The colon will flash.

If the time of day is not then entered immediately, the time will start to run from "12:00" onwards.

Setting time of day (24 hour clock)

To enter or alter the time of day the function selector must be set to "0".

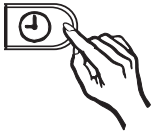

2 x

- Press the ⌚ touch control twice.

The facia text / symbol for "time of day" lights up.

The colon lights up constantly.

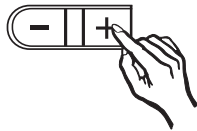

- Within the next 4 seconds use the "- / +" touch control to enter or alter the time of day.

When the colon starts flashing again the new time is accepted, (ENTER or START can also be pressed to confirm the entry). If no new time is entered within these 4 seconds, the clock reverts to the previous time.

Turning off the time of day display



- Press the ⌚ touch control three times.

The display area goes dark.

Showing time of day display again



2 x

- Press the ⌚ touch control twice.

The time of day display will reappear.

Notes on use

Selecting a function

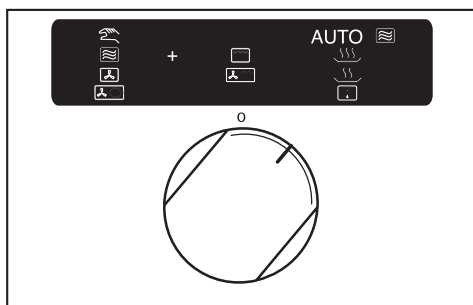
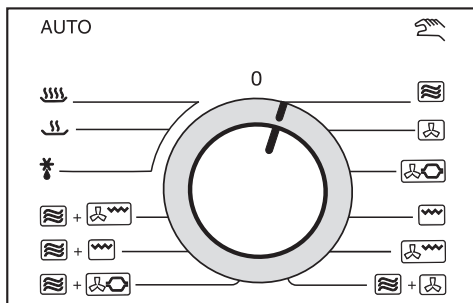

■ Use the function selector to choose the function you require:

See "Operating modes" and "Operation – Controls".

Depending on model the following will appear in the display:

- MANUAL for a "solo" or combination programme.
- AUTOMATIC, when an Automatic Programme is selected.
- the selected function.

Selecting a microwave power level / temperature

Each function has been assigned a suggested power level (for the microwave) or a suggested temperature (for traditional oven functions).

These will appear in the data entry display.

Microwave

- Solo 600 W
- Combination programmes 300 W

- Fan Heat 160 °C
- Auto Roast* 160 °C
- Grill 220 °C
- Fan Grill 200 °C

* Continuation roasting temperature
Initial boosted temperature 230 °C

You can use the "- /+" touch control to alter the microwave power level and the temperature if those pre-set by the system are not suitable.

When using the **microwave function** you can chose from the following power levels:

Solo:

- 80 W, 150 W, 300 W, 450 W, 600 W, 850 W, 1200 W.

Combination programmes:

- 80 W, 150 W, 300 W, 450 W.

Memory:

- 0 W, 80 W, 150 W, 300 W, 450 W, 600 W, 850 W, 1200 W.

When using **traditional oven functions** the following settings are possible:

Solo, combination programmes:

Fan Heat	30 – 200 °C
Auto Roast	110 – 200 °C
Grill	200 – 250 °C
Fan Grill.	100 – 200 °C

The temperature is entered in 5 °C-steps.

Entering the time

After entering a power level or temperature, use the – /+ touch control to enter the time required for the cooking process:

For Microwave on its own "Solo" select:

- . . . up to 5 minutes in 10 second steps
- . . . from 5 to 10 minutes in 30 second steps.
- . . . from 10 to 30 minutes in 1 minute steps.
- . . . from 30 to 60 minutes in 2 minute steps.

If the maximum microwave power level (1200 W) is selected, then a maximum of 10 minutes only can be entered.

For Combination programmes select:

- . . . up to 30 minutes in 1 minute steps.
- . . . from 30 to 90 minutes in 2 minute steps.

If you have chosen the Microwave + Grill combination programme, you can select a maximum of 30 minutes only.

The time entered will appear in the display in minutes : seconds.



For Traditional oven functions on their own select:

- . . . time in minute steps

You can select a time of up to 3 hours microwave only (Solo) or 1 hour and 30 minutes (combination programmes).

Exceptions: If you have chosen a temperature of up to 100 °C when using Fan Heat (Solo or combination programme), you can enter a time of up to 9 hours 59 minutes.

For Grill by itself (Solo) a time up to a maximum of 1 hour, or in a combination programme up to 30 minutes may be chosen.

The time entered will appear in the display in hours and minutes.



Operating modes

With solo microwave, a power level and time are entered. With traditional oven functions a temperature is selected and a time can also be entered.

- Use the function selector to select the required function.

The display will show the suggested power level or temperature.

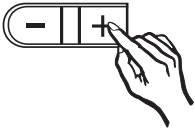

- If these are not suitable alter them using the "- /+" control.

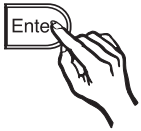

- Confirm by pressing Enter.

The following will appear in the data entry display:

- "0:00" (microwave):

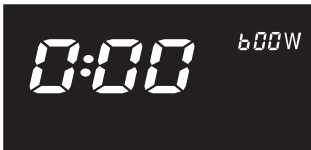

or

- "0h:00" (traditional oven function).

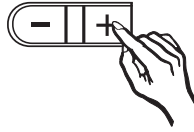

- Use the "- /+" touch control to enter a time for the cooking process.



- Press the Start touch control.

The time entered will be accepted and will appear in the selected settings display.

The time remaining will appear in the data entry display.

Only for traditional oven functions:

The process can also be started without first entering a time.

- After selecting the temperature press the Start touch control.

The temperature selected will be accepted and will appear in the selected settings display.

The actual temperature in the oven will appear in the data entry display. The temperature will rise in 1°C steps until it has reached the set temperature. It will then be displayed constantly. If the temperature falls again, e.g. when the door is opened the actual temperature will count down in 1 °C steps before rising again.

Combination programmes

Microwave mode is combined with one of the traditional oven functions. Before starting enter a microwave power setting, time and a temperature. A time can also be entered for the selected traditional oven function.

- Use the function selector to select the programme you want.

A suggested microwave power level "300 W" will appear in the display.

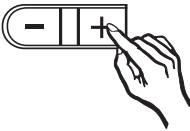

- If this is not suitable alter it using the "- /+" touch control.



- Confirm by pressing Enter.

"0:00" will appear in the display.

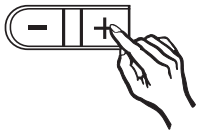

- Use the "- /+" touch control to enter a time for the microwave mode.

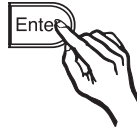

- Confirm by pressing Enter.

The suggested temperature for the traditional oven function will then appear in the display.

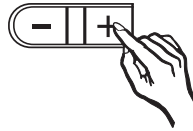

- Use the "- /+" touch control to select a temperature.

If both modes are to run for the same length of time it is not necessary to enter a time for the traditional oven function.



- Press the Start touch control.

The temperature which you have selected will be accepted and will appear in the selected settings display.

The time entered for microwave mode will also be used by the traditional oven function and appear in the selected settings display.

The time entered will count down in the data entry display.

Combination programmes

If the two operating modes are run for a different length of time from each other, a time must be entered for the traditional oven function at the start of the programme.



- After selecting the temperature, press the Enter touch control.

"0h:00" will appear in the data entry display.

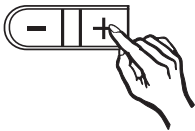

- Use the "- /+" control to enter the appropriate time for the traditional oven function.



- Then press the Start touch control.

The time selected will be accepted and will appear in the selected settings display.

The display will show the remaining time for the longer function counting down.

At the end of the time for the function with the shorter duration an audible tone will sound. That function will be switched off automatically. The settings will remain in the selected settings display, however, until the end of the entire programme.

Example:

A time of 5 minutes has been set for the microwave and 10 minutes for the traditional oven function.

10 minutes will be shown in the display area after the programme has started. The time will count down towards zero.

The appliance will operate both the microwave and traditional oven functions for the first 5 minutes.

After 5 minutes an audible tone will sound once and the system will automatically switch the microwave off. The appliance will now continue to operate using only the traditional oven function.

Automatic programmes

Cooking, reheating or defrosting processes are divided up into various food groups. The time and microwave power levels are selected automatically by the system.

- Use the function selector to select the programme you want.

The food groups available for that particular programme will appear illuminated in the display area for food groups.

The following food groups are available with the following programmes:

- Cooking :

meat, poultry, fish, fruit, soup, casseroles, vegetables.

- Reheating :

meat, poultry, fish, soup, plated meals, casseroles, vegetables.

- Defrosting :

meat, poultry, fish, fruit, bread, soup, plated meals, casseroles, vegetables.

Procedure:

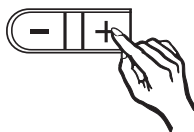

Use the "- /+" touch control to select the required food group.

The relevant text area will light up.



- Confirm by pressing Enter.

The suggested weight of "50 g" will appear in the data entry display.



- Use the "+" touch control to enter the weight of the food (without container).

Automatic programmes

- Begin the programme by pressing the Start touch control

The time which is needed for the programme will appear in the data entry display. :

- for a time up to 60 minutes it will appear in minutes:seconds, e.g. 2:30.
- for a time over 60 minutes it will appear in hours:minutes, e.g. 1h:30.

The time counts down to "0.00" or "0h:00".

A short audible tone will sound after about half of the time has elapsed, indicating that the food should now be turned or stirred.

Exception:

No tone will sound if a weight which has a corresponding time of less than 2 minutes has been entered.

The automatic programmes use various power settings.

Operating noises may vary during a programme because the cool air fan rotates more slowly on the lower power settings.

If the food has not been sufficiently defrosted, reheated or cooked at the end of the programme, do not choose the automatic programme for a second time but rather continue by entering a microwave power setting and time.

Automatic programmes

Programme	Food Group	maximum weight in kg
Cooking	meat	2.0
	poultry	2.0
	fish	2.0
	fruit	2.0
	soup	2.5
	casseroles	2.5
	vegetables	2.0
Reheating	meat	2.0
	poultry	2.0
	fish	2.0
	soup	2.0
	plated meals	2.0
	casseroles	2.0
	vegetables	2.0
Defrosting	meat	3.0
	poultry	4.0
	fish	2.0
	fruit	2.0
	bread	2.0
	soup	2.5
	plated meals	2.0
	casseroles	2.5
	vegetables	2.0

– up to 4 kg but between two 100 g steps, should be rounded down if less than 49 g and rounded up if more than 50 g.

Examples:

actual weight: 124 g
= weight entered as: 100 g.

actual weight: 125 g
= weight entered as: 150 g.

actual weight: 174 g
= weight entered as: 150 g

actual weight: 175 g
= weight entered as: 200 g

actual weight: 2.349 kg
= weight entered as: 2.3 kg.

actual weight: 2.350 kg
= weight entered as: 2.4 kg.

Depending on the programme and food group selected, a maximum weight of 4 kg can be entered. See chart.

Weights of

... 50 g to 1 kg are entered in 50 g steps.

... 1 kg to 4 kg are entered in 0.1 kg steps.

Weights of

– up to 1 kg but between two 50 g steps should be rounded down, if less than 24 g or 74 g and rounded up if more than 25 g or 75 g.

Altering entered data

Before starting a process

If you discover before the start of a process that you have made an error with the data entry then



- Press the Stop/C touch control once.

The power level entered (for microwave and combination programmes) or the temperature (for traditional oven functions) will appear in the display.

If an automatic programme has been chosen, then the relevant text/symbol for the food groups will light up in display.

- Use the touch controls to enter the settings you require.
- Press the Start touch control.

After starting a process

If you discover after the process has begun that you have made an error with the data entry, press the Stop/C touch control to interrupt the process.

The time is halted at the point of interruption.

The cool air fan continues to run during this period.

To correct a time entry:



- Press the Stop/C touch control once.

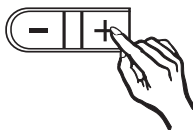

- Enter the time you require using the "- /+" touch control.



- Press the Start touch control.

You cannot correct the time if you have chosen a combination or automatic programme.

To correct a microwave power level / temperature, or a food group:



2 x

- Press the Stop/C touch control twice.

The power level (for microwave and combination programmes) or the temperature (for traditional oven modes) previously entered and stored in memory will appear in the display.

If an automatic programme has been chosen then the relevant text/symbol for the food group will light up.

- Use the touch controls to enter the settings you require.
- Press the Start touch control.

Memory function

When using the microwave different power levels may be required by the one process, e.g. defrosting followed by reheating or cooking food.

These different power levels can be stored together with the relevant times required and called up all at once using the Memory touch control. Food should be left to stand for a few minutes at room temperature when it has been cooked in the microwave. This is to ensure that the temperature is evenly distributed throughout the food. This standing time can also be stored using the Memory function (Microwave power setting: 0 W).

Up to 5 stages can be stored in sequence. Use the Memory function as follows:

Enter the stages of the programme in the sequence you wish them to run.

- Turn the function selector to microwave mode.
- Enter the microwave power level.
- Press Enter to confirm.
- Enter the time.

In total a microwave power level of 1200 W for a maximum of 10 minutes and a microwave power level of 850 W for a maximum of 60 minutes can be entered.



- Press the Memory touch control to store the entries in the memory.

Enter each stage in this way. The number after the "M" in the display area will indicate which memory stage is being stored.



- Begin the programme by pressing the Start touch control.

The time left to run for the programme will count down in the data entry display.

The time and the microwave power level for the stage currently counting down will appear in the selected settings display.

After each programme stage, the number in the display will disappear and the next process will begin.

Correcting programmes





- Press the Stop/C touch control.

All the entries which had been made are now cancelled and need to be entered again.

Short step system

Using the short step system you can store microwave power levels and times for frequently used processes.

- Turn the function selector to microwave mode.
- Press the  touch control.

Up to a maximum of 5 programme times can be stored. Call up the individual programmes by pressing the  touch control several times.

A microwave power setting of 1200 W with times of 1, 2, 3, 4 or 5 minutes has been factory set for these programmes.

The stored settings appear each time in the display area.



To alter the stored settings :

- Select the programme you require by pressing the  touch control once or several times.



The stored time will appear in the display.

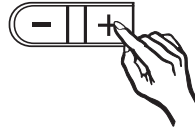

- Select the time you require using the "- /+" touch control.

You can enter a time up to a maximum of 10 minutes.



- Press Enter to accept this newly selected time.

The stored microwave power setting will appear in the display area.

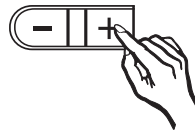

- Select the power setting you require using the "- /+" touch control.





- If you want to store these settings permanently, press (and hold) the  touch control until an audible tone sounds.

The most recently selected microwave power level will appear in the display area.

Short step system

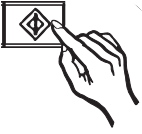
Starting the Short Step system



- Select the programme by pressing the  touch control once or several times.
- If necessary, alter the stored settings using the touch controls.



- Begin the process by pressing the Start touch control.

The time will count down in the data entry display.

Automatic delay start

You can delay the actual start of a programme by up to 23 hours and 59 minutes after programming a process.

- Make sure the correct time of day shows in the display before starting (refer to "Setting the time of day"), and that the door is shut.
- Enter the process required.

All operating modes and programmes can be pre-selected.

- Press the  touch control once be-



fore starting the process.

The text/symbol for "Start time" will light



up in the display. The time of day will appear in the display.

- Enter the start time you require using the "+" touch control.



If you press the "+" touch control for too long by mistake, use the "-" touch control to correct the start time.

- Begin the programme by pressing the Start touch control.

The time of day will reappear in the display. The text/symbol for "Start time" will light up. The stored entries will appear in the display area for selected settings. If delaying the start of a programme stored using the "Memory function", the entries for the M1 Programme will be displayed.

Press the  touch control at any time and the selected start time will reappear in the display.

This will light up for approx. 4 seconds and will then be replaced by the time of day.

The interior light does not come on during the delay start time. You can switch the oven compartment light on for a short while by pressing the Enter touch control. The oven light will go off again automatically after approx. 10 seconds.

If you press the Stop/C touch control during the period running up to the start time all entries are cancelled.

Opening the door

After a microwave process has started the door will remain locked until the time entered has elapsed.

In order to cancel the door lock you must interrupt the process.



- Press the Stop/C touch control to release the door lock.

The time is halted at the point of interruption.

The cool air fan continues to run during this period.

If the door is kept open for longer than 5 minutes then the settings which have been selected will be cancelled.

To continue the process:

- close the door,
- press the Start touch control.

If the Start touch control

- is not pressed within 5 seconds, an audible tone will sound,
- is not pressed within 5 minutes, all the settings which have been selected will be cancelled.

Audible tone

An audible tone will sound 3 times at the end of a process.

A colon will appear in the data entry display.

If the appliance is not then attended to, the audible tone will sound at 5 minute intervals for approx. one hour .

This reminder can be terminated by

- turning the function selector to "0".

The time of day will appear in the display. The display will remain dark if the time of day display was switched off.

- opening the door,

or

- pressing any touch control, with the exception of the "- /+" control. The "- /+" control is locked.

The most recently selected microwave power level (for microwave and combination programmes) or the most recently selected temperature (for traditional oven functions) will appear in the display.

If an automatic programme has been chosen, the relevant text/symbol for the food groups will light up in the display.

Starting another process

- Stop the audible tone by opening the door for a brief moment or by pressing any touch control with the exception of the "- /+" control. The "- /+" control is locked.
- Use the touch controls to enter the settings you require.
- Press the Start touch control.

When a process has finished

- Turn the function selector to "0".

The cool air fan may run on for a little while at the end of a process using a traditional oven function, making a slight noise. The cool air fan will switch off automatically when the temperature in the cooking compartment falls to a certain level.

Minute Minder

You can set the minute minder to time other activities in the kitchen, e.g. boiling eggs on a hob.

The function selector must be at "0" before the minute minder is used.



- Press the \odot touch control once.

The text/symbol for "Minute minder" appears in the display.

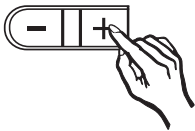

- Use the "- /+" touch control to enter the "short time".

The minute minder option allows you to select a time of up to 90 minutes.



- Press the Start touch control.

The time counts down to "0.00" in the display.

Altering a minute minder entry



- Press the Stop/C touch control.

The minute minder time will be interrupted.

- Use the "- / +" touch control to alter the time.

- Press the Start touch control.

If the minute minder is not re-activated by pressing the Start touch control within 5 minutes, the remaining time is cancelled. The time of day reappears in the display.

Exception: The time of day will not appear if the display has been switched off.

When the minute minder time has elapsed

- three audible tones will sound,
- the time of day will reappear in the display,
- the text/symbol for "Minute Minder" will flash for approx. 1 minute.

Exception: If the time of day display has been switched off then the display will remain dark.

The audible tone and the text/symbol for "Minute Minder" can be terminated by,

- pressing any touch control.

Energy saving functions

If preferred you can

- programme the appliance so that the display is not as bright at night ("Night time dimming" function),
- switch off the oven compartment light.

"Night time dimming"

When this function is switched on the display is programmed to be less bright between 10 pm and 6 am (22.00 to 6.00 hours).

To activate this function:

The function selector must be at "0".

- Press and hold the "+" and Enter touch controls and turn the function selector one position to the right.

"01:0" will appear in the display.

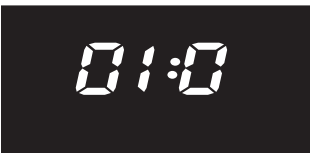

The indicator lights in the "- /+" and Enter touch controls will light up.

- Press the Enter touch control.

"01:1" will appear in the display.



- Turn the function selector to "0" again.

The function will remain activated until you switch it off again. It will also remain activated even if there is a power cut.

To switch this function off again:

The function selector must be at "0".

- Press and hold the "+" and Enter touch controls and turn the function selector one position to the right.

"01:1" will appear in the display.

The indicator lights in the "- /+" and Enter touch controls will light up.

- Press the Enter touch control.

"01:0" will appear in the display.

Turn the function selector to "0" again.

Energy saving functions

Switching off the oven interior lighting

The function selector must be at "0".

- Press and hold the "+" and Enter touch controls and turn the function selector one position to the right.

The following will appear in the display:

- "01:0" = "Night time dimming" switched off,
- "01:1" = "Night time dimming" switched on.

The indicator lights in the "- /+" and Enter touch controls will light up.

- Press the "+" touch control.

"02:0" will appear in the display.



The indicator light in the Enter touch control will light up.

- Press the Enter touch control.

"02:1" will appear in the display.

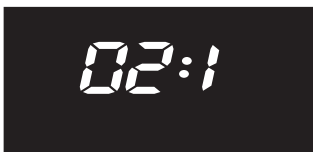

- Turn the function selector to "0".

The interior lighting will now switch itself off after a programme has begun.

Press the Enter touch control if you want to switch the interior lighting on for a short while. It will switch itself off automatically after approx. 10 seconds.

The interior lighting will remain de-selected even after a power cut.

To switch the interior lighting back on again:

The function selector must be at "0".

- Press and hold the "+" and Enter touch controls and turn the function selector one position to the right.

The following will appear in the display:

- "01:0" = "Night time dimming" switched off,
- "01:1" = "Night time dimming" switched on.

The indicator lights in the "- /+" and Enter touch controls will light up.

- Press the "+" touch control.

"02:1" will appear in the display.

The indicator light in the Enter touch control will light up.

- Press the Enter touch control.

"02:0" will appear in the display.

Turn the function selector to "0".

This safety feature prevents functions being entered unintentionally.

To activate the programming lock:

The programming lock can only be activated when

- no minute minder entry has been made,
- the function selector is at "0".

- Press the "-" touch control until a key symbol appears in the display:



The key symbol will go out after a short time.

The time of day will reappear in the display.

Exception: If the time of day display has been switched off, then the display will remain dark.

The key symbol will reappear in the display as soon as the function selector is turned to another position or any touch control is pressed.

To cancel the programming lock:

- Press the "-" touch control until the key symbol in the display goes out.

The appliance can now be used again.

Defrosting

Automatic defrosting †

This programme is suitable for defrosting meat, poultry, fish, fruit, bread, soup, plated meals, casseroles and vegetables.

This programme is also the best for defrosting dishes containing other ingredients besides meat, poultry or fish, e.g. goulash, casseroles, soups etc. Select "Casseroles" from the food groups.

When using the automatic defrost programme select "Bread" from the food groups for defrosting cakes which have a moist topping, such as fruit or cream cheese and also for defrosting bread rolls.

See "Automatic programmes" for details on using this programme.

Microwave

This function can be used on its own to defrost food gently and quickly.

The following settings are recommended as a general guide:

- 150 W
for defrosting quite delicate food, e.g. milk, cake etc.
- 80 W
for defrosting very delicate food, e.g. cream, butter, gateau and cheese.

Defrosting:

- Remove food from its packaging and place it in a microwave-safe container.
- Place the container in the middle of the oven floor.

If defrosting a large quantity, e.g. 2 kg of fish, you can also use the glass tray as a container. Place the glass tray on the oven floor.

Turn, stir or separate the food about half-way through the defrosting time.

The automatic programme has an audible tone which sounds as a reminder.

After defrosting

Allow the food to stand at room temperature long enough to allow the temperature to spread evenly throughout the food.

For more detailed information on defrosting consult a good microwave or microwave combi-oven cookbook.

Chart for defrosting food

	Quantity	Auto-Weight	150 W time in mins.	80.W	Standing time in mins * at room temperature
Dairy products					
Cream	$\frac{1}{4}$ l	-	-	12-14	5 - 10
Butter	250 g	-	-	8 - 10	5 - 10
Cheese slices	250 g	-	-	6 - 8	10 - 15
Milk	$\frac{1}{2}$ l	-	12 - 14	-	10 - 15
Cream cheese	250 g	-	10 - 12	-	10 - 15
Cakes / Pastry / Bread					
Madeira cake	pce appx 100 g.	-	1 - 2	-	5 - 10
Madeira cake	300 g	-	4 - 6	-	5 - 10
Fruit cake	3 pieces 300 g	-	6 - 8	-	10 - 15
Queen cakes	3 pieces 300 g .	-	5 - 7	-	5 - 10
Cream cake	1 piece 100 g.	-	-	$1\frac{1}{2}$ -2	5 - 10
Yeast buns	4 pieces.	-	6 - 8	-	5 - 10
Roll	1 piece 50 g	-	$1\frac{1}{2}$ -2	-	5 - 10
Rolls	4 pieces 200 g	-	4 - 6	-	5 - 10
Bread	1 slice	-	$\frac{1}{2}$ -1	-	3 - 4
Meat, Poultry, Fish, Fruit, Bread, Soup, Plated meals, Casseroles, Vegetables		X	-	-	5 - 10

X = Enter the weight of food. Time and power setting are selected automatically.

* During this time the temperature spreads evenly through the food.

Consult a good microwave / microwave combi-oven cookbook for further details on defrosting these and other foods.

The information given in this chart is intended only as a guide.

Reheating

Automatic reheating

This programme is suitable for reheating meat, poultry, fish, soup, plated meals, casseroles and vegetables.

See "Automatic programmes" for details on using this programme.

Microwave

Microwave mode is suitable for reheating foods which are unsuitable for the automatic programme.

Select the following microwave power settings to reheat food

- drinks 1200 W,
- food 850 W or 600 W
- * food for babies 450 W.

* Baby food

We do not recommend heating or reheating foods or drinks for babies or young children in the microwave oven. Any decision to do this is the responsibility of the user, and should only be done with the utmost care.

Always remove the lids from jars, especially jars of baby food. Remove the rubber teat and seal top before warming baby bottles.

Pasteurised or sterilised cooked food should be gently heated at 450 watts, and tasted so that it is not too hot for a baby's palate before serving. Other food or drink when reheated should be heated to a high temperature and allowed to cool to a suitable heat for consumption.

For made-up milk follow the manufacturer's instructions.

After reheating stir the food or shake the container and check that the temperature does not pose any danger. Double check after it has been left to stand.

Always use a lid or cover for reheating food, except when a drier finish is needed, e.g. breaded poultry / meat.

When reheating liquids place the boiling rod supplied into the cup or glass.

Never reheat hard boiled eggs in a microwave oven, even without the shell. The eggs can burst.

Do not reheat food in the oven in heat-retaining bags intended for normal ovens. These usually contain a thin layer of aluminium foil which reflects microwaves. This reflected energy can cause the outer paper covering to become so hot that it ignites.

The time required depends largely on the nature of the food, its initial temperature and the amount to be cooked. Food taken straight from the refrigerator takes longer to reheat than food stored at room temperature.

Always ensure that the food is adequately heated.

If in any doubt that a sufficiently high temperature has been reached, continue reheating for a little longer.

Stir or turn food from time to time during cooking. Stir the food from the outside towards the middle, as food heats more quickly from the outside. With the automatic programme an audible tone sounds as a reminder.

Heating on two levels

Because of the way that microwaves are distributed from top and bottom it is possible to reheat food on two levels at the same time.

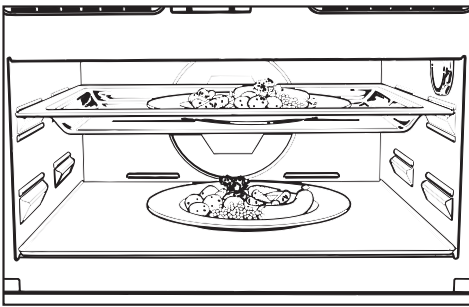

- Place dishes on the oven floor and on the glass tray. Insert the glass tray on the upper level supports.

You can arrange

- three plates (Ø 20 cm) in a triangle, two plates (Ø 22 cm) side by side, or two plates (Ø 24.5 cm) diagonally on the oven floor,
- two plates (Ø 20 cm) side by side, or two plates (Ø 22 cm) diagonally on the glass tray.

After reheating

Be careful when removing a dish from the oven. It may be hot.

Although heat is not normally produced in the container itself by the microwaves, (apart from stoneware and similar dishes), heat transfer from the food to the container may be considerable, making the container itself hot.

Allow food to stand for a few minutes at room temperature once a programme has ended to allow heat to be distributed evenly.

After reheating food, especially food for babies and small children, stir the food or shake the container and check that the temperature does not pose any danger. Double check after it has been left to stand.

For more detailed information on reheating consult a good microwave or microwave combi-oven cookbook.

Reheating

Chart for reheating food

Drinks **	Quantity	Automatic-Programme	Microwave setting		Standing time in mins * at room temperature.
			1200 W Time in mins.	450 W Time in mins.	
Coffee, drinking temp. 60 – 65 °C	1 cup, 0.2 l	–	1/2 – 1	–	–
Milk, drinking temp. 60 – 65 °C	1 cup, 0.2 l	–	1 – 1 1/2***	–	–
Water to the boil	1 cup, 1/8 l	–	1 – 1 1/2	–	–
Baby bottle (Milk) !!	apx 200ccm	–	–	1/2 – 1***	1
Mulled wine, Grog drink temp. 60–65°C	1 glass, 0.2 l	–	1 – 1 1/2	–	–

Food ***	Quantity	Automatic-Programme	Microwave setting		Standing time in mins * at room temperature
			600 W Time mins.	450 W Time mins.	
Baby food !!	1 jar, 200 g	–	–	1/2 – 1	1
Powder potato	250 g	–	3 – 5	–	1
Hollandaise sauce	1/4 l	–	–	3	1
Meat, Poultry, Fish, Soup, Plated meal, Casserole, Vegetables		X	–	–	2

!! See Warning in Section on Reheating.

X = Enter the weight of the food and power are selected automatically.

* During this time the temperature spreads evenly through the food.

** Put the boiling rod in the container.

*** Times are based on an initial temperature of approx 5 °C.

For food not normally stored in a fridge assume an initial temperature of 20 °C.

All food except delicate sauces should be reheated to 70 – 75 °C Temperature should be tested for palatability before serving to invalids or the elderly. See note on food and drink for babies.

Consult a good microwave / microwave combi-oven cookbook for further details on reheating these and other foods.

The information given in this chart is intended only as a guide.

Automatic Cooking  is suitable for cooking meat and poultry which are not required to be crisped or browned, fish, soups, casseroles and vegetables.

See "Automatic programmes" for details on using this programme.

Microwave

This method is suitable for cooking noodles, pasta, rice and semolina pudding etc.

First select 850 W and then turn down to 450 W to continue cooking, or 150 W for simmering.

Place the food in a microwave-safe dish and cover it.

Place the dish on the oven floor.

Vegetable cooking times depend on the texture of the vegetable. Fresh vegetables contain more water than vegetables which have been stored and usually cook more quickly. Add a little water to vegetables which have been kept stored. Stir and turn food at least once during cooking.

Food with a thick skin or peel, such as tomatoes, sausages, jacket potatoes and aubergines, should be pierced or cut in several places to allow steam to escape and prevent the food from bursting.

Eggs can only be cooked in their shells in the microwave oven in a specially designed egg-boiling device available from specialist shops. Similarly, hard-boiled eggs should not be reheated in the microwave oven as this may lead to the eggs bursting, even once they have been removed from the oven.

Eggs can be cooked without their shells in the microwave oven only if the yolk membrane has been punctured several times first. The pressure could otherwise cause the egg yolk to explode.

Cooking

Fan Heat

This method is recommended for everyday cooking, e.g. cakes, pastry, meringues, pizza, potatoes and other vegetables.

Slide the glass tray with the rack into the lowest runner level.

The following containers are suitable:

Ovenproof china or glassware, earthenware, pans with heat resistant handles.

Cover foods such as potatoes or vegetables which are to be simmered or poached, to avoid them drying out.

Where a crisp finish is required e.g. for meat, cook without a lid.

Combination programmes

Microwave + Fan Heat +

is suitable if you want a shorter cooking time.

Microwave + Grill +

is suitable for cooking food which requires a crisp finish or browning.

Place the cooking container on the glass tray and slide into the lowest runner level.

Only use heat-resistant, microwave-safe crockery. No metal.

Cover food being cooked in the Microwave + Fan Heat combination to avoid it drying out.

Leave food being cooked in the Microwave + Grill combination uncovered so that it can brown.

Ensure that food, such as meat and fish, are cooked for an appropriate length of time.

For more detailed information on cooking consult a good microwave or microwave combi-oven cookbook.

Chart for cooking food

	Quantity	Automatic- Programme	Microwave setting 850 W + 450 W		Standing time * in mins at room tempeare.
			Time mins.	Time mins.	
Trout	2 at 250 g	–	4	+ + 5 – 6	2 – 3
Desserts					
Apricot creme	1/2 l	–	4 – 5	–	–
Vanilla creme	1/2 l	–	5 – 6	–	–
Fish and Poultry dishes (not browned), Fish, Fruit, Soup, Casserole, Vegetables					
		X	–	–	2 – 3

X = Enter the weight of the food, time and power are selected automatically

* During this time the temperature spreads evenly through the food.

Consult a good microwave / microwave combi-oven cookbook for futher details on cooking these and other foods.

The information given in this chart is intended only as a guide.

Cooking

Chart for cooking and crisping/browning food

	Pre-cook* Microwave		Cook + Brown, Crisp Microwave + Grill		
	850 W Time in mins.	+	Microwave setting in W	Temperature in °C	Time in mins.
Paprika boats ¹⁾	3	+	450	220	10 – 12
Root veg. Lasagne ¹⁾	4	+	450	220	22 – 24
Emmental-Noodles ²⁾	–		450	220	8 – 12**
Vegetable Burger ³⁾	4	+	450	200	28 – 30
Potato Dauphinoise ³⁾	–		450	220	25 – 27
Coated Fish ¹⁾	–		450	220	8 – 12**
Fish in Cheese Sauce ¹⁾	–		450	220	14 – 18**

	Quantity	Microwave + Grill			+	Microwave
		Microwave setting in W	Temperature in °C	Time in mins.		450 W Time/mins.
Meat and poultry¹⁾						
Ham	1000 g	450	200	28 – 30	+	12 – 15
Porkrib	500 g	450	200	15 - 20		–
Lamb	750 g	450	200	28 - 30		–
Mince	750 g	450	200	25 - 30		–
Chicken, half ¹⁾	1000 g	150	250	28 – 30		–
Boned turkey roll	1000 g	450	220	44 – 48		–
Snacks ²⁾						
Tuna on toast	2 pcs	450	250	3 – 4**		–
Tuna on toast	4 pcs	450	250	5 – 6**		–
Sausage wrapped in cheese and ham	4 pcs	450	250	5 – 6**		–

* Pre-cook vegetables / sauce or fillings with lid on

** Pre-heat grill for approx. 5 minutes, place food on the rack

1) First shelf level from bottom

2) Second shelf level from bottom

3) Oven floor

Slide the glass tray with the rack in at the appropriate shelf level.

Allow a standing time at room temperature of:

approx. 5 minutes, and 2 minutes or more for cooking times under 10 minutes.

Consult a good microwave / microwave combi-oven cookbook for further details on cooking these and other foods.

The information given in this chart is intended only as a guide.

Defrosting and Re-heating / Cooking

For simultaneous defrosting and reheating or cooking the following functions are suitable:

Microwave

This method is suitable for defrosting and then reheating or cooking deep frozen ready made meals which you do not wish to brown.

Deep-frozen ready made meals can be defrosted and immediately reheated or cooked in the same process, selecting 850 W and then 450 W.

Remove the food from its packaging and place in a covered microwave-safe dish for defrosting and reheating or cooking. Exception: Minced meat should be left uncovered while cooking. Soups, stew and vegetables should be stirred several times during the process. Separate slices of meat half-way through the programme. Turn pieces of meat and fish at the half-way stage.

Deep-frozen ready made meals in cardboard trays which, according to manufacturer's instructions are suitable for use in a normal oven, are microwave-safe.

Microwave + Grill +

This method is suitable for defrosting and then reheating or cooking deep frozen ready made meals, which are to be crisped and browned. Select microwave power 450 watts and a temperature of 220 – 250 °C.

Put the ready made meal in a heat resistant, microwave-proof dish, and place on the glass tray. Slide the tray into the 2nd level. Do not cover.

Ready made meals in aluminium dishes can be placed directly on to the glass tray. If this does not brown the food as much as you would like, next time put the dish on the rack, and slide this together with the glass tray into the first level from the bottom.

For more detailed information on defrosting followed by reheating or cooking consult a good microwave or microwave combi-oven cookbook.

Defrosting and Re-heating / Cooking

Chart for defrosting and reheating or cooking of deep frozen ready made meals

	Quantity	Microwave setting 850 W Time in mins.	+ 450 W Time in mins.	Standing time at room tempera- ture * in mins.	
Soups					
Cream soups	0.75 l	7	+	8 – 10	2
Clear beef broth with vegetables	0.8 l	8	+	10 – 12	2
Fish					
White fillet	400 g	4	+	10 – 12	2
Sea trout in herb sauce	400 g	3	+	10 – 12	2
Meat					
Burgers	160 g	3		–	1
Roast	450 g	3	+	7 – 8	1
Goulash	250 g	3	+	5 – 6	1
Dumplings	450 g	3	+	6 – 7	2
Chicken fricassé	450 g	3	+	7 – 8	2
Vegetables					
Puree	450 g	4	+	7 – 8	2
Vegetable casserole + 1/8 l Water	400 g	5	+	6 – 7	3
Rice, Noodles, Plated meals					
Paella + 0.1 l Water	400 g	6 – 7		–	2
Tortellini + 0.2 l Milk / water	450 g	5	+	4 – 5	2
Lasagne	420 g	3	+	10 – 12	2

* During this time the temperature spreads evenly through the food.

Consult a good microwave / microwave combi-oven cookbook for further details on defrosting followed by reheating or cooking of these and other foods.

The information given in this chart is intended only as a guide.

Defrosting and Re-heating / Cooking

Defrosting and reheating, or cooking and crisping or browning of deep frozen ready made meals

	Quantity	combined operating Microwave + Grill			Standing time at room temp. * in mins.
		Microwave- setting in W	Temp. in °C	Time in mins.	
Bistro Baguettes	250 g	450	250	8 – 10	2
Lasagne	450 g	450	220	14 – 16	2
Potatoes, broccoli and ham in sauce	350 g	450	220	14 – 16	2
Wholemeal noodles with vegetables and ham	350 g	450	220	16 – 18	2
Fish fillet	450 g	450	220	18 – 20	2
2 spiced burgers	250 g	450	250	8 – 10	2

* During this time the temperature spreads evenly through the food.

Pre-cooked meals in heat resistant dishes suitable for microwaving.

Pre-cooked meals in aluminium containers can be put directly onto the glass tray. Remove the cover. Slide the glass tray into the second shelf level

Consult a good microwave / microwave combi-oven cookbook for further details on defrosting followed by reheating or cooking of these and other foods.

The information given in this chart is intended only as a guide.



Grilling

The following grill settings are suitable for browning food:

Grill  is suitable for browning dishes such as cauliflower cheese. It can be used for grilling very thin meat or fish.

Fan Grill  is suitable for grilling larger pieces of meat, e.g. poultry and kebabs.

Combination programmes:

Microwave + Grill  + 

and

Microwave + Fan Grill  + 

are suitable for cooking food which requires a crisp finish or browning. Microwave power output is limited to 450 W maximum for the total grilling time.

Preparation of meat or fish

Clean, wipe and season. Do not salt slices of meat beforehand as this draws the juices out.

Add a little oil if necessary. Other fats quickly become black or cause the food to smoke. A little butter can be added to chicken if desired.

Clean flat fish and slices of fish in the normal way. To enhance the taste add a little salt or squeeze a little lemon juice over the fish.

Remember to fit the grease filter to the backpanel in front of the fan when using Fan Grill, either on its own (Solo) or in a combination programme.

Pre-heat the grill for approx. 5 minutes with the oven door shut.
Do not select a microwave setting.

Brush the rack with oil and place the prepared food on the rack.
It is best to grill food of a similar thickness at the same time so that the grilling time for each item does not vary too greatly.

Slide the glass tray with the rack

- into the upper (2nd) runner level for flat pieces of food
- into the lowest runner level for thicker pieces of food,

Most items should be turned half way through cooking.
To grill thicker pieces of food more gradually after an initial high temperature, continue grilling at a lower temperature setting to allow the food to cook through to the centre.

Test to see if cooked

One way of finding out how far through a piece of meat has been cooked is to press down on it with a spoon:

- If there is very little resistance to the pressure of the spoon, it is still red on the inside ("rare").
- If there is some resistance the inside will be pink ("medium").
- If there is great resistance, it is thoroughly cooked through ("well done").

For more detailed information on grilling consult a good microwave or microwave combi-oven cookbook.

Chart for grilling

Pre-heat the grill for approx five minutes.

Flat items ¹⁾	Grill	
	Temp. in °C	Total grill time in mins. ³⁾
Steaks	250	10 – 20
Burgers	220	10 – 20
Sausage	240	8 – 14
Fish fillet	250	10 – 20
Toast	250	2 – 5
Toast with topping	250	5 – 7
Tomatoes	250	8 – 10
Peaches	230	6 – 10

Larger pieces ²⁾	Fan Grill ⁴⁾		Microwave + Fan Grill ⁴⁾		
	Temp. in °C	total grill time in mins. ³⁾	Microwave power in W	Temp. in °C	total grill time in mins. ³⁾
Kebab / mixed grill	200	15 – 35	300	200	20 – 25
Chicken (ca. 1 kg)	200	50 – 60	150	200	36 – 40
Rolled meat Ø 7 cm (approx. 1 kg)	200	70 - 80	300	200	44 - 54

1) upper runner level

2) lower runner level

3) Turn the food half way through grilling.

4) Fit the grease filter for Fan Grill and the Microwave + Fan Grill combination programme.

Consult a good microwave / microwave combi-oven cookbook for further details on grilling these and other foods. The information given in this chart is intended only as a guide.



Roasting

When open roasting on the rack fit the grease filter in front of the fan grille at the rear of the oven.

Auto Roast

Use Auto Roast  to give meat or poultry a crisp browned finish.

Microwave + Auto Roast +

Select combination programme Microwave + Auto Roast  +  to cook in a shorter time.

The combination programme is not usually suitable for cooking roast beef or fillet steak. The centre would be too well cooked before the exterior is browned.

Put meat or poultry into the oven without pre-heating.

Exception: Pre-heat at the temperature suggested when cooking beef and beef fillet.

Cooking in a covered pot is highly recommended:

- the meat stays succulent,
- the oven interior stays cleaner than when roasting on the rack.

Half way through the cooking time remove the lid from the pot if browning the meat.

Auto Roast

Slide the glass tray with the rack into the first runner from the bottom.

The following pots can be used: roasting tins, pots, earthenware, oven-proof glass, roasting foil. Make sure the pot and lid have heat-resistant handles.

The roasting time depends on the type of meat, the size and thickness of the cut, and can be calculated as follows:

Thickness of the roasting cut of meat x time per cm per type of meat, see chart.

Type of meat	Time per cm thickness
Beef topside / Venison	15 – 18 mins.
Pork / Veal / Lamb	12 – 15 mins.
Sirloin fillet	8 – 10 mins.

Example:

Lamb roast, 8 cm thick

8 x 12 minutes per cm = 96 mins. roasting time

(NB: there is also a traditional calculation of approx. 20 minutes to the lb, (454 grammes) and 20 minutes over).

The larger the roast, the lower the temperature to be selected. For cuts above 3 kg select a temperature approx. 10 °C lower than that given in the roasting chart. Roasting will take longer at the lower temperature, but will be more even.

Note: When roasting on the rack set a temperature of approx. 20 °C lower than in a covered pot.

Browning only occurs towards the end of the roasting time.

15 – 20 minutes before the end of roasting time take the lid off the pot.

Do not select a higher temperature than that advised. This would brown, but not completely cook the meat.

Microwave + Auto Roast +

Slide the glass tray with the rack into the first runner level from the bottom.

Use only heat resistant pots, with no metal in the pot or lid. Microwaves cannot penetrate metal to reach the food in the pot.

If using roasting foil

- cut the foil approx. 40 cm longer than the piece of food
- and tie carefully. Make sure the pot, foil and ties are suitable for microwave use.

Together with Auto roast, select a microwave setting for the total cooking time of:

- 300 W for roasting meat or fish,
- 150 W for roasting poultry.

After the roasting process is finished

Take the roast out of the oven, wrap in aluminium foil and leave to stand for about 10 minutes. This helps retain the juices when the meat is carved.

Useful hints

Roasting in a covered pot

Season the meat and place in the pot. Add some knobs of butter or margarine or a little oil or cooking fat. Add about $\frac{1}{8}$ litre water when roasting a big lean joint of meat (2 – 3 kg), or roasting poultry with a high fat content.

Roasting on the rack

Add a little fat or oil to very lean meat or place a few strips of streaky bacon on the top. Do not add too much liquid to the tray during cooking as this will hinder the browning process. Please note that open roasting can give rise to excessive smoke.

Roasting poultry

For a crisp finish, baste the poultry 10 minutes before the end of cooking time with slightly salted water.

Roasting deep frozen meat

Deep frozen meat should be defrosted first.

For more detailed information on roasting consult a good microwave or microwave combi-oven cookbook.

Roasting

Chart for roasting

	Auto Roast ¹⁾		Microwave + Auto Roast ¹⁾		
	Temperature in °C ²⁾	Time in mins.	Microwave-setting in W	Temperature in °C ²⁾	Time in mins.
Beef topside (appx. 1 kg)	180 – 200	100 – 120	300	190	76 – 86
Sirloin, Steak ³⁾ (appx. 1 kg)	190 – 200	35 – 45	–	–	–
Venison (appx. 1 kg)	180 – 200	90 – 110	300	190	66 – 76
Pork, Shoulder (appx. 1 kg)	170 – 190	100 – 120	300	180	50 – 60
Pork fillet, Chops in piece (appx. 1 kg)	170 – 190	60 – 80	300	180	46 – 56
Ham (appx. 1 kg)	170 – 190	60 – 80	300	180	40 – 50
Meat loaf (appx. 1 kg)	170 – 190	50 – 60	300	180	30 – 34
Veal (appx. 1 kg)	170 – 190	100 – 120	300	180	50 – 60
Shoulder of lamb (appx. 1.5 kg)	170 – 190	90 – 120	300	180	66 – 76
Poultry (0.8 – 1 kg)	170 – 190	50 – 60	150	180	40 – 46
Poultry (appx. 2 kg)	170 – 190	90 – 110	150	180	70 – 80
Poultry (appx. 4 kg)	160 – 180	150 – 180	150	170	100 – 120
Whole fish (appx. 1.5 kg)	160 – 180	45 – 55	300	170	35 – 40

The times given are calculated on the basis of an oven which has not been pre-heated.

1) With Auto Roast and the Combination programme Microwave + Auto Roast fit the grease filter.

2) Roasting in a pot.

If open roasting on the rack, set the temperature 20 °C lower.

3) Pre-heat the oven.

Consult a good microwave / microwave combi-oven cookbook for further details on roasting these and other foods.

The information given in this chart is intended only as a guide.

Fan Heat

This method is suitable for baking small cakes, swiss roll, pastry doughs.

Most types of heat-resistant tins or dishes are suitable, including thin-walled and bright, non-reflective metal tins.

Slide the glass tray with the rack into the 1st runner from the bottom, and place the baking tin on this.

Do not push the glass tray right to the back wall, but leave a gap of about 2 cm. Otherwise browning will be uneven.

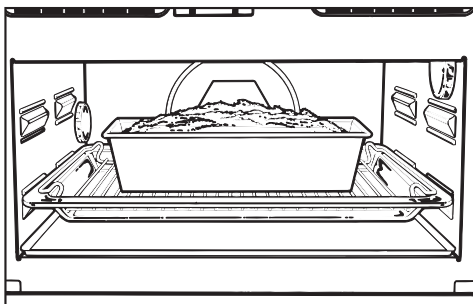

Baking time should not be too long. This can lead to the cake etc. drying out.

Increasing the temperature from suggested levels and reducing the time can have an adverse effect on browning. To achieve even browning it might be better to select a slightly longer cooking time at a slightly lower temperature.

Microwave + Fan Heat +

This combination programme is suitable for doughs which require longer baking, such as rubbed in and beaten mixtures, yeast recipes and cheese-cake.

For preference use ovenproof glass or ceramic baking dishes, as microwaves can penetrate these materials into the food being cooked. Metal tins would reflect microwaves, so that they would only reach the cakes from the top, resulting in a longer cooking time.

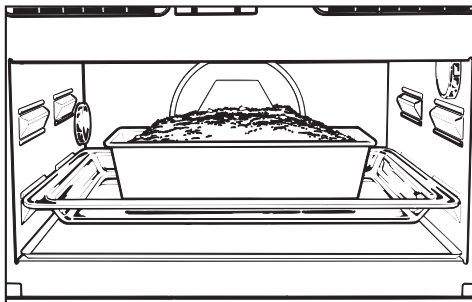

Slide the glass tray into the 1st runner from the bottom, and place the baking dish on this.

Do not push the glass tray right to the back wall, but leave a gap of about 2 cm. Otherwise browning will be uneven.

Baking

With metal baking tins there may be sparking. Try positioning the tin differently on the glass tray, and make sure the tin does not touch the interior walls.

If sparking continues, do not use this tin again in microwave combination mode.

Do not use paper based containers coated with aluminium foil, such as are sometimes provided with packet cake mixes. There is the danger of these catching fire.

Switch on the microwave setting for the total cooking time. The microwave setting should not be higher than 150 W.

Temperature settings, times and microwave power settings in the Baking Chart are suggestions only. Select an average temperature and time for first attempts and adapt accordingly.

If the grease filter is in position in front of the fan grille opening this lengthens baking time.

At the end of the shorter time given, check to see whether the cake etc. is done. Insert a wooden or metal skewer in the centre. If it comes out clean without dough sticking to it, the cake is ready.

For more detailed information on baking consult a good microwave or microwave combi-oven cookbook.

Chart for baking

	Fan Heat		Microwave + Fan Heat		
	Temp. in °C	Time in mins.	Microwave setting in W	Temp. in °C	Time in mins.
Creamed mixture					
Victoria sandwich	160 – 165	20 – 25	–	–	–
Farmhouse fruit cake	–	–	150	130	60 – 70
Nut cake (glass tray) ¹⁾	150 – 170	25 – 30	150	160	20 – 25
Nut cake (tin)	150 – 170	60 – 70	150	160	40 – 46
Fresh fruit cake with topping (glass tray)	150 – 170	45 – 50	150	160	30 – 35
Fresh fruit cake (glass tray)	150 – 170	35 – 45	150	160	25 – 30
Fresh fruit cake (tin)	150 – 170	50 – 60	150	160	40 – 44
Flan base	150 – 170	25 – 30	150	160	15 – 20
Whisked mixture					
Tart	160 – 180	30 – 35	–	–	–
Flan base	160 – 180	20 – 25	–	–	–
Swiss roll	160 – 180	15 – 20	–	–	–
Rubbed-in mixture					
Tart / flan base	150 – 170	20 – 25	150	160	15 – 20
Crumble cake	150 – 170	40 – 50	150	160	30 – 36
Small cakes ¹⁾	150 – 170	15 – 25	–	–	–
Cheesecake	150 – 170	75 – 85	150	160	64 – 70
Apple pie	150 – 170	45 – 55	150	160	38 – 48
Apricot tart with topping	150 – 170	60 – 70	150	160	50 – 60
Savoury pastry ²⁾	190 – 200	25 – 35	–	–	–
Yeast mixtures					
Hot cross buns	160 – 170	20 – 25	150	–	–
Granary loaf	–	–	300	200	30 – 35
Stollen	150 – 170	50 – 60	150	160	30 – 34
White loaf	160 – 180	40 – 50	–	–	–
Wholemeal loaf	170 – 190	50 – 55	–	–	–
Pizza (glass tray)	170 – 190	40 – 50	150	180	36 – 40
Choux pastry					
Eclairs ¹⁾	160 – 180	25 – 30	–	–	–
Flaky pastry¹⁾					
	170 – 190	20 – 25	–	–	–
Meringues					
	70	180 – 240	–	–	–
Macaroons¹⁾					
	120 – 140	35 – 45	–	–	–

The times given are calculated on the basis of an oven which has not been pre-heated.

With a pre-heated oven shorten times by up to 10 minutes.

1) First and second shelf support levels. 2) Pre-heat the oven.

Consult the cookbook supplied with your oven and/or a good microwave / microwave combi-oven cookbook for further details on these and other foods.

The information given in this chart is intended only as a guide.

Cleaning and care

Appliance front and control panel

- All external surfaces and controls can be cleaned using warm water with a little washing up liquid applied with a soft sponge.
- Wipe the surfaces dry using a soft cloth.

E-Cloth

A microfibre "E-Cloth" is available from the Miele UK Spare Parts Department, Part number 98013530, which is suitable for cleaning surfaces such as stainless steel, glass, plastic and chrome without the use of chemicals.

To prevent the risk of scratches and damage to the surface structure of glass, stainless steel and aluminium fronted appliances pay particular attention to the following cleaning instructions.

Glass fronted appliances

The appliance front and controls are susceptible to scratches and abrasion.

Avoid:

- abrasive cleaning agents, e.g. powder cleaners and cream cleaners.
- abrasive sponges, e.g. pot scourers or sponges which have been previously used with abrasive cleaning agents,
- oven sprays.

Clean the door handle and the control elements regularly, preferably after each use. This will help prevent grease or other deposits adhering to surfaces and becoming impossible to remove.

Aluminium fronted appliances

Aluminium is affected by the way that light falls it, by the surrounding environment and by the angle you observe it from.

Aluminium surfaces and controls may suffer discolouration or damage if soiling is left on them for too long. Remove any soiling straight away.

The appliance front and controls are susceptible to scratches and abrasion.

Avoid:

- cleaning agents containing soda, acids or chlorides,
- abrasive cleaning agents, e.g. powder cleaners and cream cleaners.
- abrasive sponges, e.g. pot scourers or sponges which have been previously used with abrasive cleaning agents,
- stainless steel cleaners,
- cleaning agents containing descaling agents,
- dishwasher detergent,
- oven sprays.

Stainless steel fronted appliances

The appliance front and controls are susceptible to scratches and abrasion.

Please observe the cleaning instructions for

- stainless steel surfaces,
- stainless steel coloured controls

Stainless steel surfaces

Stainless steel surfaces can be cleaned using a proprietary non-abrasive cleaning agent designed specifically for use on stainless steel.

Avoid:

- cleaning agents containing soda, acids or chlorides,
- abrasive cleaning agents, e.g. powder cleaners and cream cleaners.
- abrasive sponges, e.g. pot scourers or sponges which have been previously used with abrasive cleaning agents.

To help prevent re-soiling, proprietary conditioning agent for stainless steel can also be used.

Apply sparingly with even pressure using a soft cloth.

Stainless steel coloured controls

The controls may suffer discolouration or damage if soiling is left on them for too long.

Remove any soiling straight away.

Avoid:

- cleaning agents containing soda, acids or chlorides,
- abrasive cleaning agents, e.g. powder cleaners and cream cleaners.
- abrasive sponges, e.g. pot scourers or sponges which have been previously used with abrasive cleaning agents,
- stainless steel cleaners,
- oven sprays.

Cleaning and care

Oven interior

The oven interior is stainless steel. The high temperatures possible when operating in a traditional oven mode can cause the steel to darken slightly.

The oven interior is hot after use. Take care not to burn yourself. Clean the oven interior regularly, preferably after each use. If left too long cleaning becomes unnecessarily difficult, and in extreme cases impossible.

Turn the function selector to the Light nsetting and clean using a solution of hot water and washing up liquid or mild detergent applied with a sponge, soft brush or damp cloth. Wipe dry with a soft cloth.

If anything has become burnt on, use a non-abrasive mild cream cleaner or a proprietary cleaner for stainless steel, applied with a non-scouring kitchen sponge.

Do not use too much water on the cloth or sponge and do not let water or any other substance find its way into any openings.

Residues of fruit juices as well as cake mixtures are best removed while the oven is warm. Spillages of fruit juices can cause lasting discoloration.

If using an oven spray, the manufacturer's instructions must be followed. Do not spray into any of the openings.

Glass back panel

The glass back panel can be removed for cleaning.

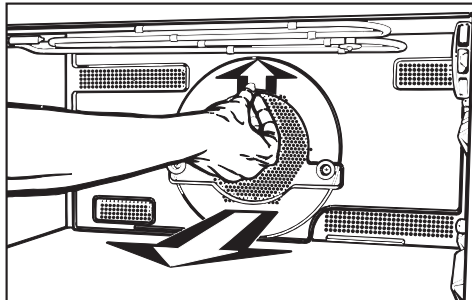

- Gently lift the glass panel and take it out carefully.
- Clean in the dishwasher or wash by hand.

When washing the glass panel by hand lay it on a smooth surface, to avoid any damage.

Do not use any scouring agents. These cause scratches.

- Reverse the procedure to refit the glass panel with care. The openings in the back wall of the oven must not be blocked.

Oven interior roof

If the oven interior roof is particularly soiled, the grill element can be lowered to make cleaning easier.

Wait until the grill element has cooled down before lowering it to avoid the danger of being burnt.

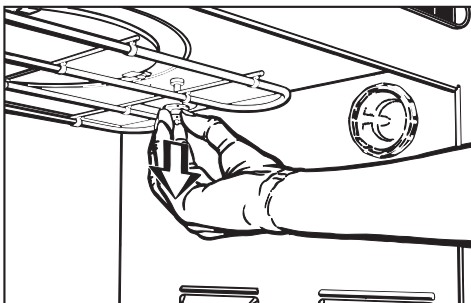

- Pull the fixing knob downwards to lower the grill element.

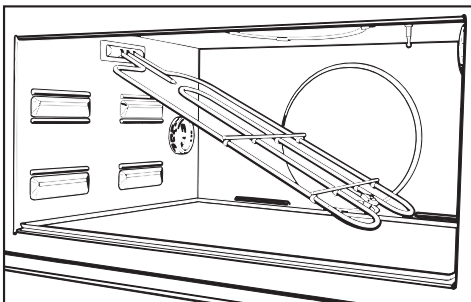

- Lower the grill element gently.

Do not use force to lower it as this could cause damage.

- After cleaning the grill element, raise it gently back up again and secure. The fixing knob must engage.

Door interior

Always keep the door interior clean. Do not use any scouring agent. Check the door and door seal at regular intervals for any sign of damage.

If any damage is noticed, the oven should not be used again in microwave mode until the fault has been rectified by a service technician.

Accessories

Grease filter

The grease filter can be washed in hot water and washing up liquid, or in the dishwasher.

Rack

Wash and dry the rack after each use. Remove stubborn soils with a stainless steel cleaner.

Glass tray

The glass tray can be washed in hot water and washing up liquid, or in the dishwasher.

Do not use scouring agents. These would scratch.

Boiling rod

The boiling rod can be washed in a dishwasher.

Problem solving guide

Repairs to this appliance should only be carried out by a suitably qualified and competent service technician approved by Miele. Unauthorised repairs could be dangerous.

The following can be corrected without calling the Miele Service Department:

What to do if

. . . the display area is dark

- Check whether:
 - the appliance is correctly plugged in,
 - the mains fuse has blown (call the Service Department),
 - the time display had been switched off (see Section on "Time of day display").

. . . nothing happens when a touch control is pressed.

- Check whether:
 - the indicator light for that control is lit up,
 - the programme lock is activated (see Section "Programme lock").

. . . a process will not start.

- Check whether:
 - if operating in microwave mode the appliance door is properly shut,
 - if operating in microwave mode a power setting and time have been entered,
 - if operating with a combination programme, the following have been entered: a power setting, a time for the microwave mode, a time and a temperature for the conventional oven operating mode.
 - if operating with an Automatic programme the weight has been entered.

. . . no operating noise is heard when the appliance door is opened during a cooking process in conventional oven mode

This is not a fault.

If the door is opened during a cooking process the door contact switch will switch off the heating and depending on the function chosen, the hot air fan.

. . . a noise is heard after a process has finished

This is not a fault.

The cooling fan continues to run for a short time. When the temperature has fallen sufficiently the fan switches off automatically.

If the door is opened during this run-on time the fan is switched off. If the door is then shut the fan will start again.

... the microwave / heating functions but not the interior lighting.

- Check whether the oven interior lighting has been switched off, (see "Energy saving functions").

If this is not the case, the halogen bulb needs replacing.

Replace with a new one as follows:

Disconnect the appliance from the electricity supply, (switch off and unplug at the socket, or remove the fuse, or switch off at the isolator as appropriate).

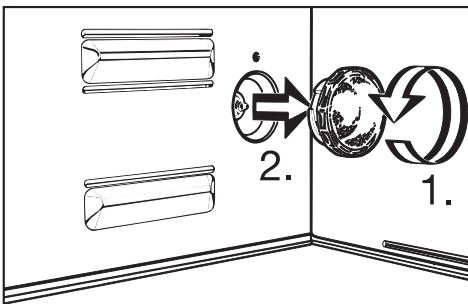
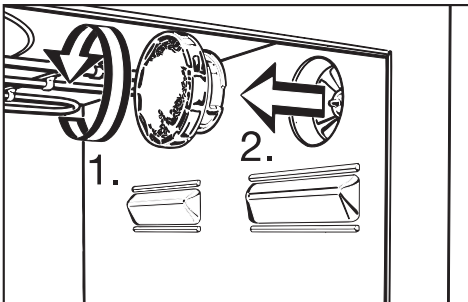

- Loosen and remove the lamp covers (1.). This may be easier using a rubber glove.

- Take out the halogen lamps (2.). Exercise caution when changing a light bulb. Halogen lights get very hot during use and will remain hot for some time after being switched off.
- Do not touch the surface directly when changing the bulb as grease particles from your fingers will adhere to the surface and damage it. Please follow manufacturer's instructions.
- Fit new halogen lamps.

Connection data for halogen lamps:
12 V, 10 W
Temperature resistant to 300 °C,
W271 socket, Osram, Type 64418

The pins must lie horizontally to the appliance. Push the lamps in until they engage.

- Screw the lamp cover back on.
- Reconnect the appliance to the mains supply.

... the food is not sufficiently heated or is not cooked at the end of a set time

- Check whether:
 - the cooking process has been interrupted and was not restarted,
 - if cooking / reheating in microwave mode the correct time was selected for the setting chosen.A lower power setting normally requires a longer time.

Problem solving guide

... cakes or biscuits are not cooked after a recommended time

- Check whether:
 - the correct temperature was set.
 - there has been a change to the recipe. The addition of more liquid or more eggs makes a moister mix which would take longer to cook.
 - whether the grease filter had been left in place. A longer time would be needed if this were the case.

... cakes or biscuits are unevenly browned

There will always be a degree of difference in browning.

- If browning is very uneven, check:
 - whether the temperature was set too high,
 - whether the glass tray had been pushed so far in that it touched the back wall,
 - whether the grease filter had been left in place on the back wall,
 - the colour and composition of the baking tins being used. Try using a different tin next time.

... food cools down too quickly after being reheated or cooked in microwave mode.

When cooked by microwaves, food begins to cook from the outside first, the inside of the food relying on the slower conduction of heat. If food is cooked at a high power level it is possible that the heat may not have reached the centre of the food. During standing time heat is transferred to the centre of the food. Food may be warm in the middle but cool on the edge.

When reheating food with different densities, such as plated meals, it is sensible to start with a low power level and lengthen the time required.

... the minute minder does not work

The short time programmed for the minute minder can only start counting down when the appliance door is shut and the Start touch control has been pressed.

... the touch control for the short step system will not register.

- Check whether:
 - microwave mode has been selected.
 - the time entered is less than 10 minutes. A time of more than 10 minutes cannot be stored.

... strange noises are heard when the microwave or microwave / combination mode is being used.

- Check whether:
 - sparks are being created by the use of metallic crockery, (see Section on Suitable crockery).
 - the food is covered with aluminium foil. If so, remove it.

... a programme can not be stored using "M".

- Check whether:
 - Microwave mode has been selected,
 - a power setting and time have been entered.

... the required time for a Memory-Programme stage can not be set

- Check whether:
 - the total of time entered for all Memory-Programme stages with a power setting of 1200 W adds up to more than 10 minutes.
 - the total time entered for all the Memory-Programme stages with a power setting of 850 W adds up to more than 60 minutes.

... An "F" appears in the display field together with a number

This combination indicates a fault message.

The fault message "**F02**" appears when the door is opened and at the same time the Start touch control is pressed.

- Disconnect the appliance from the power supply (switch off and remove the plug from the socket, or switch off at the isolator, and then reconnect immediately.

The Fault message disappears.

This also applies to the fault message "**F01**".

If the fault message remains in the display field, or reappears after Start is pressed in, call the Service department.

If an **F in combination with any other number appears** e.g. "F10", "F11", "F12",

- call the Service department.

Remember to quote the fault code displayed.

After sales service

Customer contact

In the events of any faults which you cannot easily remedy, please contact

– your Miele dealer

or

– the nearest Miele Service Department

See address on the back page.

– When contacting the Service department please quote the Model and Serial number of your appliance, given on the data plate which is located on the front of the oven interior, visible when the door is opened.

Please note that telephone calls may be monitored and recorded to improve our service.

All electrical work should be carried out by a suitably qualified and competent service technician approved by Miele in strict accordance with national and local safety regulations.

Depending on the version, the appliance is supplied with a mains cable, or a mains cable and plug for connection to a.c. 50 Hz, 230 - 240 V single phase supply.

The voltage, rated load and fuse rating are given on the data plate situated at the front of the oven interior. Please ensure that these match the household mains supply.

Connection should be made via a fused connection unit or a fused plug and a suitable switched socket, (rated load under 3000 W), or via a suitable isolator (rated load over 3000 W), which complies with national and local safety regulations, and the on/off switch should be easily accessible after the appliance has been installed.

If the socket is not accessible after installation (depending on country) an additional means of disconnection must be provided for all poles.

When switched off there must be an all-pole gap of 3 mm in the isolator switch (including switch, fuses and relays acc. to EN 60335).

For extra safety it is advisable to install a residual current device with a trip current of 30 mA (in accordance with DIN VDE 0664, VDE 0100 Section 739).

If the cable is damaged a new cable must be fitted by a Miele approved service engineer.

In certain unfavourable circumstances microwave appliances can be a source of interference. In this event please contact your dealer or the Miele Service Dept.

If the appliance is connected via an isolator switch the plug must be cut off and rendered useless.

Important U.K.

The wires in the mains lead of this appliance are coloured in accordance with the following code:

Green/yellow = Earth

Blue = Neutral

Brown = Live

As the colours of the wires in the mains lead of this appliance may not correspond with the markings identifying the terminals in your plug, proceed as follows:

The wire coloured green and yellow must be connected to the terminal in the plug which is marked with the letter E or by the earth symbol \perp or coloured green or green and yellow.

The wire coloured blue must be connected to the terminal marked with the letter "N" or coloured black. The wire coloured brown must be connected to the terminal marked with the letter "L" or coloured red (U.K.).

WARNING
THIS APPLIANCE MUST BE
EARTHED

Non-rewireable plugs BS 1363

If this machine or appliance is fitted with a non-rewireable plug, the following information applies: if the socket outlets are not suitable for the plug supplied with this product, it must be cut off and an appropriate plug fitted. The fuse carrier and fuse should be removed from the plug and disposed of. The plug cut from the flexible cord should then be disposed of and on no account be inserted into any socket elsewhere in the house (electric shock hazard).

The fuse cover must be re-fitted when changing the fuse, and if the fuse cover is lost the plug must not be used until a suitable replacement is obtained. The colour of the correct replacement cover is that of the coloured insert in the base of the plug, or the colour that is embossed in words on the base of the plug, (as applicable to the design of plug fitted).

The correct rating of the replacement fuses that are ASTA approved to BS 1362 should be fitted. Replacement covers may be purchased from your local electrical supplier, electricity showroom or Miele service agent.

All electrical work should be carried out by a competent person, in accordance with national and local safety regulations.

Depending on the version, the appliance is supplied with a mains cable, or a mains cable and plug for connection to a.c. 50 Hz, 230 - 240 V.

The voltage, rated load and fuse rating are given on the **data plate** situated at the front of the oven interior. Please ensure that these match the household mains supply.

For extra safety it is advisable to install a residual current device (RCD) with a trip current of 30 mA.

Connection for the appliance should be made via a suitable isolator which complies with national and local regulations, and which is accessible after the appliance has been built in.

Test marks

Electrical safety, C-Tick Mark

Electrically suppressed according to AS/NZS 1044

Important

The wires in the mains lead are coloured in accordance with the following code:

Green / yellow = earth

Blue = neutral

Brown = live

As the colours of the wires in the mains lead of this appliance may not correspond with the coloured markings identifying the terminals in your plug, proceed as follows:

The wire which is coloured green and yellow must be connected to the terminal in the plug which is marked with the letter E or by the earth symbol \perp or coloured green or green and yellow.

The wire which is coloured blue must be connected to the terminal which is marked with the letter N or coloured black.

The wire which is coloured brown must be connected to the terminal which is marked with the letter A or coloured red.

WARNING
THIS APPLIANCE MUST BE
EARTHED

Installation

Possibilities for installation and combination

The appliance is suitable for installation:

- in a tall unit in combination with an oven,
- in a tall unit,
- in a base unit.

Installation measurements

Installation in a tall unit in combination with an oven

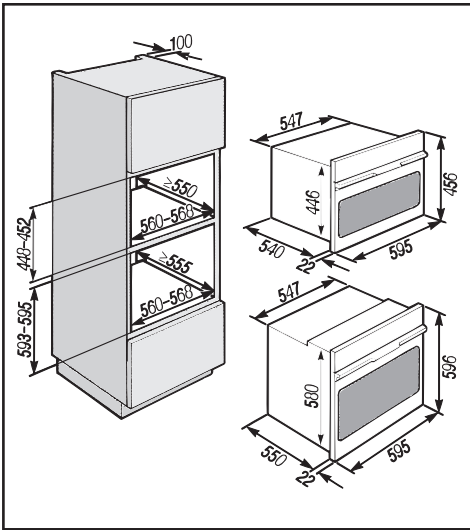

Installation in a tall unit

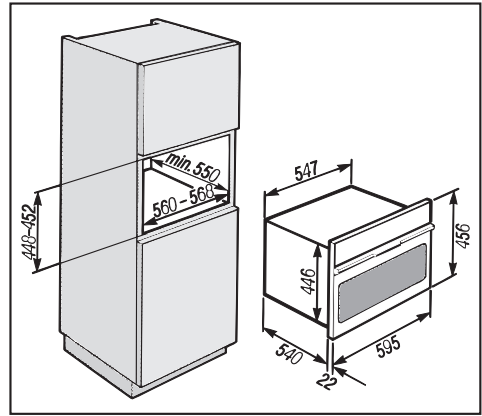

Installation in a base unit

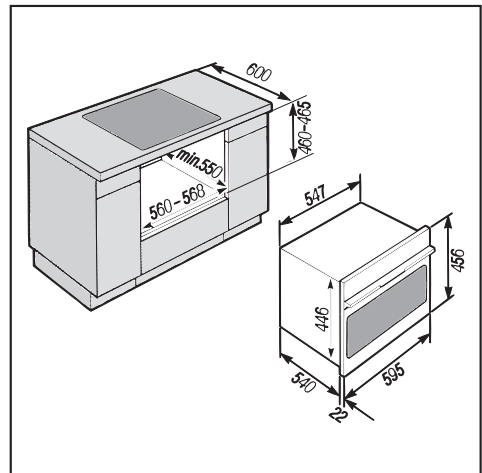

If fitted in combination with a hob, the installation instructions for the hob must also be taken into account.

Installation instructions

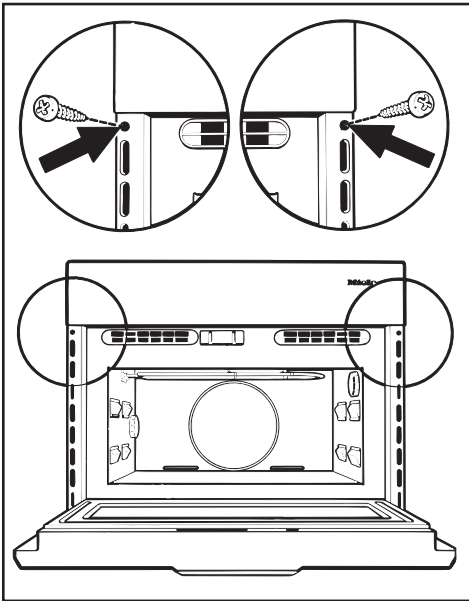

- Turn off the mains electricity supply for connecting to an isolator.
- Connect the oven to the electricity supply.
- Push the oven into the furniture unit as far as the oven trim and align.
- Open the oven door, and with two screws secure the oven to the side walls of the furniture unit through the holes in the oven trim.

The appliance must only be operated when it has been built in.

**United Kingdom:**

Miele Co. Ltd.
Fairacres, Marcham Road
Abingdon, Oxon, OX14 1TW
tel. Abingdon (01235) 554455
Service Office: (01235) 554466
fax (01235) 554477
Internet: www.miele.co.uk

Ireland:

Miele Ireland Ltd.
Broomhill Road, Tallaght, Dublin 24
Tel: (01) 46 10 710, Fax: (01) 46 10 797
Email: info@miele.ie
Internet: <http://www.miele.ie>

Australia:

Miele Australia Pty. Ltd.
A.C.N. 005635398
1 Gilbert Park Drive
Knoxfield, VIC 3180
Telephone: (03) 9764 7100
Fax: (03) 9764 7129
Internet: www.miele.com.au

Distributor New Zealand:

Steelfort Engineering Company. Ltd.
500 Rangitikei Street
Palmerston North, Priv. Bag 11045, NZ
Telephone: (06) 350 1350
Fax: (06) 356 1507

South Africa:

Miele (Pty) Ltd
304 Tungsten Road
Strijdom Park 2194
P.O.Box 1654, Randburg 2125
Tel. (011) 793-7452
Telefax (011) 793-7447
E-mail: info@miele.co.za
Internet: www.miele.co.za

Singapore:

Miele Southeast Asia
Miele Pte. Ltd.
163 Penang Road
04 - 02/03 Winsland House II
Singapore 238463
Tel : +65-67351191
Fax: +65-67351161
Email: mielesea@miele.com.sg

Hong Kong:

Miele (Hong Kong) Limited
AIA Plaza, Room 401, 4th Floor
18 Hysan Avenue
Causeway Bay
Hong Kong
Tel.: (852) 2610 1331
Fax: (852) 2610 1013
E-mail: mielehk@netnavigator.com

Free Manuals Download Website

<http://myh66.com>

<http://usermanuals.us>

<http://www.somanuals.com>

<http://www.4manuals.cc>

<http://www.manual-lib.com>

<http://www.404manual.com>

<http://www.luxmanual.com>

<http://aubethermostatmanual.com>

Golf course search by state

<http://golfingnear.com>

Email search by domain

<http://emailbydomain.com>

Auto manuals search

<http://auto.somanuals.com>

TV manuals search

<http://tv.somanuals.com>