



OM-4421

215 075Q

2007-10

Processes



Stick (SMAW) Welding



TIG (GTAW) Welding



MIG (GMAW) Welding



Flux Cored (FCAW) Welding



Air Carbon Arc (CAC-A)
Cutting and Gouging

Description



Engine Driven Welding Generator



Big Blue[®] 400P Big Blue[®] 500 X (Perkins-Powered)

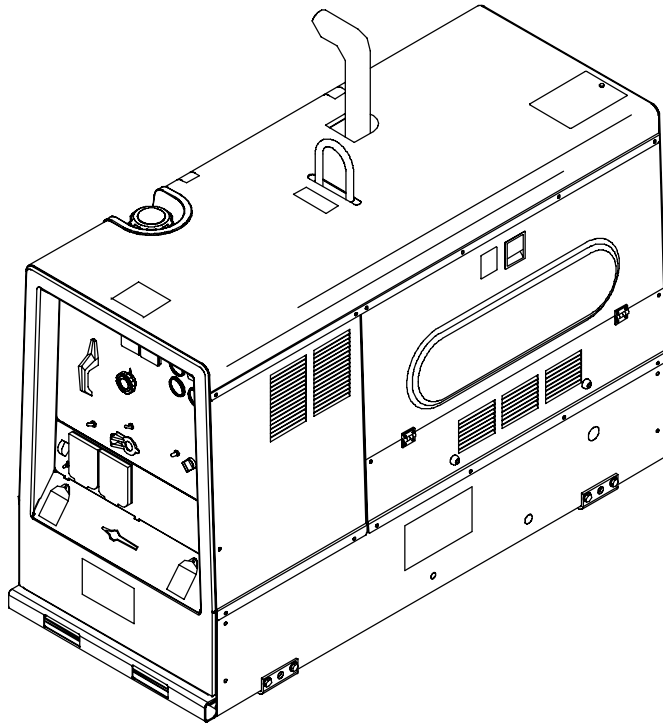

Visit our website at
www.MillerWelds.com

OWNER'S MANUAL

File: Engine Drive



From Miller to You

Thank you and congratulations on choosing Miller. Now you can get the job done and get it done right. We know you don't have time to do it any other way.

That's why when Niels Miller first started building arc welders in 1929, he made sure his products offered long-lasting value and superior quality. Like you, his customers couldn't afford anything less. Miller products had to be more than the best they could be. They had to be the best you could buy.

Today, the people that build and sell Miller products continue the tradition. They're just as committed to providing equipment and service that meets the high standards of quality and value established in 1929.

This Owner's Manual is designed to help you get the most out of your Miller products. Please take time to read the Safety precautions. They will help you protect yourself against potential hazards on the worksite.

We've made installation and operation quick and easy. With Miller you can count on years of reliable service with proper maintenance. And if for some reason the unit needs repair, there's a Troubleshooting section that will help you figure out what the problem is. The parts list will then help you to decide the exact part you may need to fix the problem. Warranty and service information for your particular model are also provided.



Miller is the first welding equipment manufacturer in the U.S.A. to be registered to the ISO 9001:2000 Quality System Standard.

Miller Electric manufactures a full line of welders and welding related equipment. For information on other quality Miller products, contact your local Miller distributor to receive the latest full line catalog or individual specification sheets. **To locate your nearest distributor or service agency call 1-800-4-A-Miller, or visit us at www.MillerWelds.com on the web.**



Working as hard as you do – every power source from Miller is backed by the most hassle-free warranty in the business.



TABLE OF CONTENTS

SECTION 1 – SAFETY PRECAUTIONS – READ BEFORE USING	1
1-1. Symbol Usage	1
1-2. Arc Welding Hazards	1
1-3. Engine Hazards	3
1-4. Compressed Air Hazards	3
1-5. Additional Symbols For Installation, Operation, And Maintenance	4
1-6. California Proposition 65 Warnings	5
1-7. Principal Safety Standards	5
1-8. EMF Information	5
SECTION 2 – CONSIGNES DE SÉCURITÉ – LIRE AVANT UTILISATION	6
2-1. Signification des symboles	6
2-2. Dangers relatifs au soudage à l'arc	6
2-3. Dangers existant en relation avec le moteur	8
2-4. Dangers liés à l'air comprimé	9
2-5. Dangers supplémentaires en relation avec l'installation, le fonctionnement et la maintenance	9
2-6. Proposition californienne 65 Avertissements	11
2-7. Principales normes de sécurité	11
2-8. Information EMF	11
SECTION 3 – DEFINITIONS	12
3-1. Warning Label Definitions (For Wordless Labels)	12
3-2. Manufacturer's Rating Labels	13
3-3. Symbols And Definitions	14
SECTION 4 – SPECIFICATIONS	15
4-1. Weld, Power, And Engine Specifications	15
4-2. Dimensions, Weights, And Operating Angles	15
4-3. Volt-Ampere Curves For CC Models	16
4-4. Volt-Ampere Curves For CC/CV Models	17
4-5. Fuel Consumption	18
4-6. Duty Cycle And Overheating	18
4-7. AC Generator Power Curve	19
4-8. Optional Three-Phase Generator Curves	19
SECTION 5 – INSTALLATION	20
5-1. Installing Welding Generator	20
5-2. Using Lifting Eye	21
5-3. Mounting Welding Generator	22
5-4. Installing Exhaust Pipe	23
5-5. Activating The Dry Charge Battery (If Applicable)	24
5-6. Connecting The Battery	24
5-7. Engine Prestart Checks	25
5-8. Connecting To Weld Output Terminals	26
5-9. Selecting Weld Cable Sizes*	27
5-10. Connecting To Remote Amperage Adjust Receptacle RC13 On CC Models	27
5-11. Connecting To Remote 14 Receptacle RC14 On CC/CV Models	28
SECTION 6 – OPERATING WELDING GENERATOR – CC MODELS	30
6-1. Front Panel Controls For CC Models (See Section 6-2)	30
6-2. Description Of Front Panel Controls For CC Models (See Section 6-1)	31
6-3. Remote Amperage Control On CC Models (Optional)	32
6-4. Weld Control/Arc Condition Information Label	32

TABLE OF CONTENTS

SECTION 7 – OPERATING WELDING GENERATOR – CC/CV MODELS	34
7-1. Front Panel Controls For CC/CV Models (See Section 7-2)	34
7-2. Description Of Front Panel Controls For CC/CV Models (See Section 7-1)	35
7-3. Process/Contactor Switch On CC/CV Models	36
7-4. Remote Voltage/Amperage Control On CC/CV Models (Optional)	37
SECTION 8 – OPERATING AUXILIARY EQUIPMENT	38
8-1. 120 Volt And 240 Volt Receptacles	38
8-2. Connecting To Optional Three-Phase Generator (CC/CV Models Only)	39
8-3. Optional Generator Power Receptacles	40
SECTION 9 – MAINTENANCE & TROUBLESHOOTING	41
9-1. Maintenance Label	41
9-2. Routine Maintenance	42
9-3. Checking Generator Brushes	43
9-4. Servicing Air Cleaner	44
9-5. Inspecting And Cleaning Optional Spark Arrestor Muffler	45
9-6. Adjusting Engine Speed	46
9-7. Servicing Fuel And Lubrication Systems	47
9-8. Overload Protection	48
9-9. Troubleshooting	49
SECTION 10 – ELECTRICAL DIAGRAMS	54
SECTION 11 – RUN-IN PROCEDURE	58
11-1. Wetstacking	58
11-2. Run-In Procedure Using Load Bank	59
11-3. Run-In Procedure Using Resistance Grid	60
SECTION 12 – GENERATOR POWER GUIDELINES	61
SECTION 13 – PARTS LIST	68
WARRANTY	

Declaration of Conformity for European Community (CE) Products

NOTE 

This information is provided for units with CE certification (see rating label on unit).

Manufacturer:

Miller Electric Mfg. Co.
1635 W. Spencer St.
Appleton, WI 54914 USA
Phone: (920) 734-9821

European Contact:

Mr. Danilo Fedolfi,
Managing Director
ITW Welding Products Italy S.r.l.
Via Privata Iseo 6/E
20098 San Giuliano
Milanese, Italy
Phone: 39(02)98290-1
Fax: 39(02)98290203

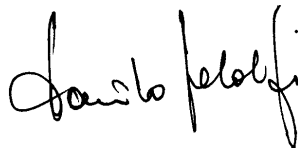

European Contact Signature: _____

Declares that the product:

Big Blue 500 X

conforms to the following Directives and Standards:

Directives

Low Voltage Directive: 73/23/EEC, 2006/95/EC

Electromagnetic compatibility Directives: 89/336/EEC, 92/31/EEC, 2004/108/EC

Machinery Directives: 98/37/EEC, 91/368/EEC, 92/31/EEC, 133/04, 93/68/EEC

Noise level of Welding Generators: 2000/14/EC

CE Marking Directive: 93/68/EEC

Standards

Arc Welding Equipment – Part 1: Welding Power Sources. IEC 60974-1 Ed. 3, 2005-07

Rotating Electrical Machines – Part 1: Rating and Performance.
IEC 60034-1 Ed. 11, 2004-04

Rotating Electrical Machines – Part 5: Classification Of Degrees Of Protection Provided By Enclosure Of Rotating Electrical Machines (IP Code) IEC 60034-5 2001-06

Arc Welding Equipment – Part 10: Electromagnetic Compatibility (EMC) Requirements. IEC 60974-10, Ed. 1.1
2004-10

The product technical file is maintained by the responsible Business Unit(s) located at the manufacturing facility.

Declaration of Conformity for European Community (CE) Products

NOTE 

This information is provided for units with CE certification (see rating label on unit).

Manufacturer:

Miller Electric Mfg. Co.
1635 W. Spencer St.
Appleton, WI 54914 USA
Phone: (920) 734-9821

European Contact:

Mr. Danilo Fedolfi,
Managing Director
ITW Welding Products Italy S.r.l.
Via Privata Iseo 6/E
20098 San Giuliano
Milanese, Italy
Phone: 39(02)98290-1
Fax: 39(02)98290203

Notified Body:

AV Technology Limited
AVTECH House
Birdhall Lane
Cheadle Heath
Stockport, Chesire SK30XU

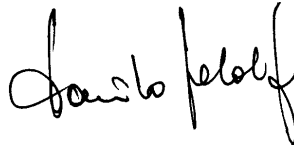

European Contact Signature: _____

The Manufacturer Declares the:

Big Blue 500 X

Conforms to Directive:

2000/14/EC, Noise Level of Welding Generators

Effective Date:

7/2004

Sound Level Information

Measured Sound Power Level: 97 dB

Guaranteed Sound Power Level: 97 dB

Sound power level requirements determined by the 100% duty cycle of 300 A, 32 V

Conforming assessment procedure 1 of Annex VI will be followed.

The product technical file is maintained by the responsible Business Unit(s) located at the manufacturing facility.

SECTION 1 – SAFETY PRECAUTIONS – READ BEFORE USING

rom_2007-04

 Protect yourself and others from injury — read and follow these precautions.

1-1. Symbol Usage



DANGER! – Indicates a hazardous situation which, if not avoided, will result in death or serious injury. The possible hazards are shown in the adjoining symbols or explained in the text.



Indicates a hazardous situation which, if not avoided, could result in death or serious injury. The possible hazards are shown in the adjoining symbols or explained in the text.

NOTICE – Indicates statements not related to personal injury.

 Indicates special instructions.



This group of symbols means Warning! Watch Out! ELECTRIC SHOCK, MOVING PARTS, and HOT PARTS hazards. Consult symbols and related instructions below for necessary actions to avoid the hazards.

1-2. Arc Welding Hazards



The symbols shown below are used throughout this manual to call attention to and identify possible hazards. When you see the symbol, watch out, and follow the related instructions to avoid the hazard. The safety information given below is only a summary of the more complete safety information found in the Safety Standards listed in Section 1-7. Read and follow all Safety Standards.



Only qualified persons should install, operate, maintain, and repair this unit.



During operation, keep everybody, especially children, away.



ELECTRIC SHOCK can kill.

Touching live electrical parts can cause fatal shocks or severe burns. The electrode and work circuit is electrically live whenever the output is on. The input power circuit and machine internal circuits are also live when power is on. In semiautomatic or automatic wire welding, the wire, wire reel, drive roll housing, and all metal parts touching the welding wire are electrically live. Incorrectly installed or improperly grounded equipment is a hazard.

- Do not touch live electrical parts.
- Wear dry, hole-free insulating gloves and body protection.
- Insulate yourself from work and ground using dry insulating mats or covers big enough to prevent any physical contact with the work or ground.
- Do not use AC output in damp areas, if movement is confined, or if there is a danger of falling.
- Use AC output ONLY if required for the welding process.
- If AC output is required, use remote output control if present on unit.
- Additional safety precautions are required when any of the following electrically hazardous conditions are present: in damp locations or while wearing wet clothing; on metal structures such as floors, gratings, or scaffolds; when in cramped positions such as sitting, kneeling, or lying; or when there is a high risk of unavoidable or accidental contact with the workpiece or ground. For these conditions, use the following equipment in order presented: 1) a semiautomatic DC constant voltage (wire) welder, 2) a DC manual (stick) welder, or 3) an AC welder with reduced open-circuit voltage. In most situations, use of a DC, constant voltage wire welder is recommended. And, do not work alone!
- Disconnect input power or stop engine before installing or servicing this equipment. Lockout/tagout input power according to OSHA 29 CFR 1910.147 (see Safety Standards).
- Properly install and ground this equipment according to its Owner's Manual and national, state, and local codes.

- Always verify the supply ground — check and be sure that input power cord ground wire is properly connected to ground terminal in disconnect box or that cord plug is connected to a properly grounded receptacle outlet.
- When making input connections, attach proper grounding conductor first – double-check connections.
- Keep cords dry, free of oil and grease, and protected from hot metal and sparks.
- Frequently inspect input power cord for damage or bare wiring — replace cord immediately if damaged — bare wiring can kill.
- Turn off all equipment when not in use.
- Do not use worn, damaged, undersized, or poorly spliced cables.
- Do not drape cables over your body.
- If earth grounding of the workpiece is required, ground it directly with a separate cable.
- Do not touch electrode if you are in contact with the work, ground, or another electrode from a different machine.
- Use only well-maintained equipment. Repair or replace damaged parts at once. Maintain unit according to manual.
- Do not touch electrode holders connected to two welding machines at the same time since double open-circuit voltage will be present.
- Wear a safety harness if working above floor level.
- Keep all panels and covers securely in place.
- Clamp work cable with good metal-to-metal contact to workpiece or worktable as near the weld as practical.
- Insulate work clamp when not connected to workpiece to prevent contact with any metal object.
- Do not connect more than one electrode or work cable to any single weld output terminal.

SIGNIFICANT DC VOLTAGE exists in inverters after stopping engine.

- Stop engine on inverter and discharge input capacitors according to instructions in Maintenance Section before touching any parts.



HOT PARTS can cause severe burns.

- Do not touch hot parts bare handed.
- Allow cooling period before working on equipment.
- To handle hot parts, use proper tools and/or wear heavy, insulated welding gloves and clothing to prevent burns.

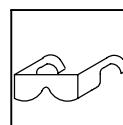

FLYING METAL or DIRT can injure eyes.

- Welding, chipping, wire brushing, and grinding cause sparks and flying metal. As welds cool, they can throw off slag.
- Wear approved safety glasses with side shields even under your welding helmet.



FUMES AND GASES can be hazardous.

Welding produces fumes and gases. Breathing these fumes and gases can be hazardous to your health.

- Keep your head out of the fumes. Do not breathe the fumes.
- If inside, ventilate the area and/or use local forced ventilation at the arc to remove welding fumes and gases.
- If ventilation is poor, wear an approved air-supplied respirator.
- Read and understand the Material Safety Data Sheets (MSDSs) and the manufacturer's instructions for metals, consumables, coatings, cleaners, and degreasers.
- Work in a confined space only if it is well ventilated, or while wearing an air-supplied respirator. Always have a trained watch-person nearby. Welding fumes and gases can displace air and lower the oxygen level causing injury or death. Be sure the breathing air is safe.
- Do not weld in locations near degreasing, cleaning, or spraying operations. The heat and rays of the arc can react with vapors to form highly toxic and irritating gases.
- Do not weld on coated metals, such as galvanized, lead, or cadmium plated steel, unless the coating is removed from the weld area, the area is well ventilated, and while wearing an air-supplied respirator. The coatings and any metals containing these elements can give off toxic fumes if welded.



BUILDUP OF GAS can injure or kill.

- Shut off shielding gas supply when not in use.
- Always ventilate confined spaces or use approved air-supplied respirator.



ARC RAYS can burn eyes and skin.

Arc rays from the welding process produce intense visible and invisible (ultraviolet and infrared) rays that can burn eyes and skin. Sparks fly off from the weld.

- Wear an approved welding helmet fitted with a proper shade of filter lenses to protect your face and eyes from arc rays and sparks when welding or watching (see ANSI Z49.1 and Z87.1 listed in Safety Standards).
- Wear approved safety glasses with side shields under your helmet.
- Use protective screens or barriers to protect others from flash, glare, and sparks; warn others not to watch the arc.
- Wear protective clothing made from durable, flame-resistant material (leather, heavy cotton, or wool) and foot protection.



WELDING can cause fire or explosion.

Welding on closed containers, such as tanks, drums, or pipes, can cause them to blow up. Sparks can fly off from the welding arc. The flying sparks, hot workpiece, and hot equipment can cause fires and burns. Accidental contact of electrode to metal objects can cause sparks, explosion, overheating, or fire. Check and be sure the area is safe before doing any welding.

- Remove all flammables within 35 ft (10.7 m) of the welding arc. If this is not possible, tightly cover them with approved covers.
- Do not weld where flying sparks can strike flammable material.
- Protect yourself and others from flying sparks and hot metal.
- Be alert that welding sparks and hot materials from welding can easily go through small cracks and openings to adjacent areas.
- Watch for fire, and keep a fire extinguisher nearby.
- Be aware that welding on a ceiling, floor, bulkhead, or partition can cause fire on the hidden side.

- Do not weld on closed containers such as tanks, drums, or pipes, unless they are properly prepared according to AWS F4.1 (see Safety Standards).
- Do not weld where the atmosphere may contain flammable dust, gas, or liquid vapors (such as gasoline).
- Connect work cable to the work as close to the welding area as practical to prevent welding current from traveling long, possibly unknown paths and causing electric shock, sparks, and fire hazards.
- Do not use welder to thaw frozen pipes.
- Remove stick electrode from holder or cut off welding wire at contact tip when not in use.
- Wear oil-free protective garments such as leather gloves, heavy shirt, cuffless trousers, high shoes, and a cap.
- Remove any combustibles, such as a butane lighter or matches, from your person before doing any welding.
- After completion of work, inspect area to ensure it is free of sparks, glowing embers, and flames.
- Use only correct fuses or circuit breakers. Do not oversize or bypass them.
- Follow requirements in OSHA 1910.252 (a) (2) (iv) and NFPA 51B for hot work and have a fire watcher and extinguisher nearby.

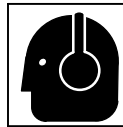

NOISE can damage hearing.

Noise from some processes or equipment can damage hearing.

- Wear approved ear protection if noise level is high.

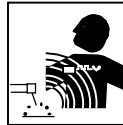

MAGNETIC FIELDS can affect Implanted Medical Devices.

- Wearers of Pacemakers and other Implanted Medical Devices should keep away.
- Implanted Medical Device wearers should consult their doctor and the device manufacturer before going near arc welding, spot welding, gouging, plasma arc cutting, or induction heating operations.



CYLINDERS can explode if damaged.

Shielding gas cylinders contain gas under high pressure. If damaged, a cylinder can explode. Since gas cylinders are normally part of the welding process, be sure to treat them carefully.

- Protect compressed gas cylinders from excessive heat, mechanical shocks, physical damage, slag, open flames, sparks, and arcs.
- Install cylinders in an upright position by securing to a stationary support or cylinder rack to prevent falling or tipping.
- Keep cylinders away from any welding or other electrical circuits.
- Never drape a welding torch over a gas cylinder.
- Never allow a welding electrode to touch any cylinder.
- Never weld on a pressurized cylinder — explosion will result.
- Use only correct shielding gas cylinders, regulators, hoses, and fittings designed for the specific application; maintain them and associated parts in good condition.
- Turn face away from valve outlet when opening cylinder valve.
- Keep protective cap in place over valve except when cylinder is in use or connected for use.
- Use the right equipment, correct procedures, and sufficient number of persons to lift and move cylinders.
- Read and follow instructions on compressed gas cylinders, associated equipment, and Compressed Gas Association (CGA) publication P-1 listed in Safety Standards.

1-3. Engine Hazards



BATTERY EXPLOSION can BLIND.

- Always wear a face shield, rubber gloves, and protective clothing when working on a battery.
- Stop engine before disconnecting or connecting battery cables or servicing battery.
- Do not allow tools to cause sparks when working on a battery.
- Do not use welder to charge batteries or jump start vehicles.
- Observe correct polarity (+ and -) on batteries.
- Disconnect negative (-) cable first and connect it last.



FUEL can cause fire or explosion.

- Stop engine and let it cool off before checking or adding fuel.
- Do not add fuel while smoking or if unit is near any sparks or open flames.
- Do not overfill tank — allow room for fuel to expand.
- Do not spill fuel. If fuel is spilled, clean up before starting engine.
- Dispose of rags in a fireproof container.
- Always keep nozzle in contact with tank when fueling.



MOVING PARTS can cause injury.

- Keep away from fans, belts, and rotors.
- Keep all doors, panels, covers, and guards closed and securely in place.
- Stop engine before installing or connecting unit.
- Have only qualified people remove doors, panels, covers, or guards for maintenance and troubleshooting as necessary.
- To prevent accidental starting during servicing, disconnect negative (-) battery cable from battery.
- Keep hands, hair, loose clothing, and tools away from moving parts.
- Reinstall doors, panels, covers, or guards when servicing is finished and before starting engine.
- Before working on generator, remove spark plugs or injectors to keep engine from kicking back or starting.
- Block flywheel so that it will not turn while working on generator components.



HOT PARTS can cause severe burns.

- Do not touch hot parts bare handed.
- Allow cooling period before working on equipment.
- To handle hot parts, use proper tools and/or wear heavy, insulated welding gloves and clothing to prevent burns.

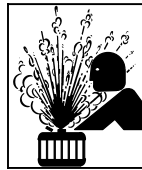

STEAM AND HOT COOLANT can burn.

- If possible, check coolant level when engine is cold to avoid scalding.
- Always check coolant level at overflow tank, if present on unit, instead of radiator (unless told otherwise in maintenance section or engine manual).
- If the engine is warm, checking is needed, and there is no overflow tank, follow the next two statements.
- Wear safety glasses and gloves and put a rag over radiator cap.
- Turn cap slightly and let pressure escape slowly before completely removing cap.

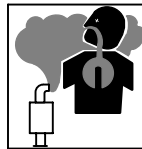

Using a generator indoors CAN KILL YOU IN MINUTES.

- Generator exhaust contains carbon monoxide. This is a poison you cannot see or smell.
- NEVER use inside a home or garage, EVEN IF doors and windows are open.
- Only use OUTSIDE and far away from windows, doors, and vents.

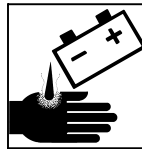

BATTERY ACID can BURN SKIN and EYES.

- Do not tip battery.
- Replace damaged battery.
- Flush eyes and skin immediately with water.



ENGINE HEAT can cause fire.

- Do not locate unit on, over, or near combustible surfaces or flammables.
- Keep exhaust and exhaust pipes way from flammables.



EXHAUST SPARKS can cause fire.

- Do not let engine exhaust sparks cause fire.
- Use approved engine exhaust spark arrestor in required areas — see applicable codes.

1-4. Compressed Air Hazards



BREATHING COMPRESSED AIR can cause serious injury or death.

- Do not use compressed air for breathing.
- Use only for cutting, gouging, and tools.

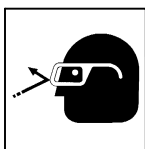

COMPRESSED AIR can cause injury.

- Wear approved safety goggles.
- Do not direct air stream toward self or others.



TRAPPED AIR PRESSURE AND WHIPPING HOSES can cause injury.

- Release air pressure from tools and system before servicing, adding or changing attachments, or opening compressor oil drain or oil fill cap.



HOT METAL from air arc cutting and gouging can cause fire or explosion.

- Do not cut or gouge near flammables.
- Watch for fire; keep extinguisher nearby.



HOT PARTS can cause burns and injury.

- Do not touch hot compressor or air system parts.
- Let system cool down before touching or servicing.

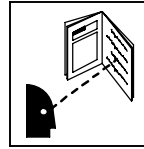

READ INSTRUCTIONS.

- Read Owner's Manual before using or servicing unit.
- Stop engine and release air pressure before servicing.
- Use only genuine replacement parts from the manufacturer.

1-5. Additional Symbols For Installation, Operation, And Maintenance



FIRE OR EXPLOSION hazard.

- Do not install or place unit on, over, or near combustible surfaces.
- Do not install unit near flammables.
- Do not overload building wiring – be sure power supply system is properly sized, rated, and protected to handle this unit.



FALLING UNIT can cause injury.

- Use lifting eye to lift unit and properly installed accessories only, NOT gas cylinders. Do not exceed maximum lift eye weight rating (see Specifications).
- Lift and support unit only with proper equipment and correct procedures.
- If using lift forks to move unit, be sure forks are long enough to extend beyond opposite side of unit.

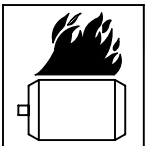

OVERHEATING can damage motors.

- Turn off or unplug equipment before starting or stopping engine.
- Do not let low voltage and frequency caused by low engine speed damage electric motors.
- Do not connect 50 or 60 Hertz motors to the 100 Hertz receptacle where applicable.

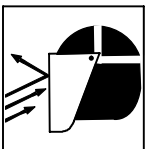

FLYING SPARKS can cause injury.

- Wear a face shield to protect eyes and face.
- Shape tungsten electrode only on grinder with proper guards in a safe location wearing proper face, hand, and body protection.
- Sparks can cause fires — keep flammables away.



MOVING PARTS can cause injury.

- Keep away from moving parts.
- Keep away from pinch points such as drive rolls.

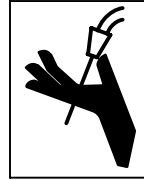

WELDING WIRE can cause injury.

- Do not press gun trigger until instructed to do so.
- Do not point gun toward any part of the body, other people, or any metal when threading welding wire.

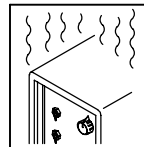

OVERUSE can cause OVERHEATING.

- Allow cooling period; follow rated duty cycle.
- Reduce current or reduce duty cycle before starting to weld again.
- Do not block or filter airflow to unit.

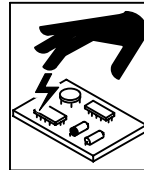

STATIC (ESD) can damage PC boards.

- Put on grounded wrist strap BEFORE handling boards or parts.
- Use proper static-proof bags and boxes to store, move, or ship PC boards.

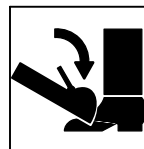

TILTING OF TRAILER can cause injury.

- Use tongue jack or blocks to support weight.
- Properly install welding generator onto trailer according to instructions supplied with trailer.

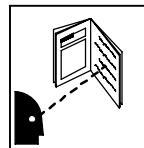

READ INSTRUCTIONS.

- Read Owner's Manual before using or servicing unit.
- Use only genuine replacement parts from the manufacturer.
- Perform engine and air compressor maintenance and service according to this manual and the engine/air compressor (if applicable) manuals.

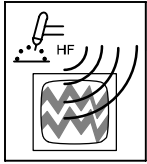

H.F. RADIATION can cause interference.

- High-frequency (H.F.) can interfere with radio navigation, safety services, computers, and communications equipment.
- Have only qualified persons familiar with electronic equipment perform this installation.
- The user is responsible for having a qualified electrician promptly correct any interference problem resulting from the installation.
- If notified by the FCC about interference, stop using the equipment at once.
- Have the installation regularly checked and maintained.
- Keep high-frequency source doors and panels tightly shut, keep spark gaps at correct setting, and use grounding and shielding to minimize the possibility of interference.

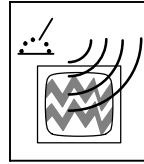

ARC WELDING can cause interference.

- Electromagnetic energy can interfere with sensitive electronic equipment such as micro-processors, computers, and computer-driven equipment such as robots.
- Be sure all equipment in the welding area is electromagnetically compatible.
- To reduce possible interference, keep weld cables as short as possible, close together, and down low, such as on the floor.
- Locate welding operation 100 meters from any sensitive electronic equipment.
- Be sure this welding machine is installed and grounded according to this manual.
- If interference still occurs, the user must take extra measures such as moving the welding machine, using shielded cables, using line filters, or shielding the work area.

1-6. California Proposition 65 Warnings

- ⚠** Welding or cutting equipment produces fumes or gases which contain chemicals known to the State of California to cause birth defects and, in some cases, cancer. (California Health & Safety Code Section 25249.5 et seq.)
- ⚠** Battery posts, terminals and related accessories contain lead and lead compounds, chemicals known to the State of California to cause cancer and birth defects or other reproductive harm. Wash hands after handling.

For Gasoline Engines:

- ⚠** Engine exhaust contains chemicals known to the State of California to cause cancer, birth defects, or other reproductive harm.

For Diesel Engines:

- ⚠** Diesel engine exhaust and some of its constituents are known to the State of California to cause cancer, birth defects, and other reproductive harm.

1-7. Principal Safety Standards

Safety in Welding, Cutting, and Allied Processes, ANSI Standard Z49.1, from Global Engineering Documents (phone: 1-877-413-5184, website: www.global.ihs.com).

Recommended Safe Practices for the Preparation for Welding and Cutting of Containers and Piping, American Welding Society Standard AWS F4.1, from Global Engineering Documents (phone: 1-877-413-5184, website: www.global.ihs.com).

National Electrical Code, NFPA Standard 70, from National Fire Protection Association, P.O. Box 9101, Quincy, MA 02269-9101 (phone: 617-770-3000, website: www.nfpa.org and www.sparky.org).

Safe Handling of Compressed Gases in Cylinders, CGA Pamphlet P-1, from Compressed Gas Association, 4221 Walney Road, 5th Floor, Chantilly, VA 20151 (phone: 703-788-2700, website: www.cganet.com).

Code for Safety in Welding and Cutting, CSA Standard W117.2, from Canadian Standards Association, Standards Sales, 5060 Mississauga,

Ontario, Canada L4W 5NS (phone: 800-463-6727 or in Toronto 416-747-4044, website: www.csa-international.org).

Safe Practice For Occupational And Educational Eye And Face Protection, ANSI Standard Z87.1, from American National Standards Institute, 25 West 43rd Street, New York, NY 10036-8002 (phone: 212-642-4900, website: www.ansi.org).

Standard for Fire Prevention During Welding, Cutting, and Other Hot Work, NFPA Standard 51B, from National Fire Protection Association, P.O. Box 9101, Quincy, MA 02269-9101 (phone: 617-770-3000, website: www.nfpa.org).

OSHA, Occupational Safety and Health Standards for General Industry, Title 29, Code of Federal Regulations (CFR), Part 1910, Subpart Q, and Part 1926, Subpart J, from U.S. Government Printing Office, Superintendent of Documents, P.O. Box 371954, Pittsburgh, PA 15250-7954 (phone: 1-866-512-1800) (there are 10 Regional Offices—phone for Region 5, Chicago, is 312-353-2220, website: www.osha.gov).

1-8. EMF Information

Considerations About Welding And The Effects Of Low Frequency Electric And Magnetic Fields

Welding current, as it flows through welding cables, will cause electromagnetic fields. There has been and still is some concern about such fields. However, after examining more than 500 studies spanning 17 years of research, a special blue ribbon committee of the National Research Council concluded that: "The body of evidence, in the committee's judgment, has not demonstrated that exposure to power-frequency electric and magnetic fields is a human-health hazard." However, studies are still going forth and evidence continues to be examined. Until the final conclusions of the research are reached, you may wish to minimize your exposure to electromagnetic fields when welding or cutting.

To reduce magnetic fields in the workplace, use the following procedures:

1. Keep cables close together by twisting or taping them, or using a cable cover.
2. Arrange cables to one side and away from the operator.
3. Do not coil or drape cables around your body.
4. Keep welding power source and cables as far away from operator as practical.
5. Connect work clamp to workpiece as close to the weld as possible.

About Implanted Medical Devices:

Implanted Medical Device wearers should consult their doctor and the device manufacturer before performing or going near arc welding, spot welding, gouging, plasma arc cutting, or induction heating operations. If cleared by your doctor, then following the above procedures is recommended.

SECTION 2 – CONSIGNES DE SÉCURITÉ – LIRE AVANT UTILISATION

rom_2007-04fre

⚠ Se protéger, ainsi que toute autre personne travaillant sur les lieux, contre les étincelles et le métal chaud.

2-1. Signification des symboles



DANGER! – Indique une situation dangereuse qui si on l'évite pas peut donner la mort ou des blessures graves. Les dangers possibles sont montrés par les symboles joints ou sont expliqués dans le texte.



Indique une situation dangereuse qui si on l'évite pas peut donner la mort ou des blessures graves. Les dangers possibles sont montrés par les symboles joints ou sont expliqués dans le texte.

NOTE – Indique des déclarations pas en relation avec des blessures personnelles.

 Indique des instructions spécifiques.



Ce groupe de symboles veut dire Avertissement! Attention! DANGER DE CHOC ELECTRIQUE, PIECES EN MOUVEMENT, et PIECES CHAUDES. Consulter les symboles et les instructions ci-dessous y afférant pour les actions nécessaires afin d'éviter le danger.

2-2. Dangers relatifs au soudage à l'arc



Les symboles présentés ci-après sont utilisés tout au long du présent manuel pour attirer votre attention et identifier les risques de danger. Lorsque vous voyez un symbole, soyez vigilant et suivez les directives mentionnées afin d'éviter tout danger. Les consignes de sécurité présentées ci-après ne font que résumer l'information contenue dans les normes de sécurité énumérées à la section 2-7. Veuillez lire et respecter toutes ces normes de sécurité.



L'installation, l'utilisation, l'entretien et les réparations ne doivent être confiés qu'à des personnes qualifiées.



Au cours de l'utilisation, tenir toute personne à l'écart et plus particulièrement les enfants.



UN CHOC ÉLECTRIQUE peut tuer.

Un simple contact avec des pièces électriques peut provoquer une électrocution ou des blessures graves. L'électrode et le circuit de soudage sont sous tension

dès que l'appareil est sur ON. Le circuit d'entrée et les circuits internes de l'appareil sont également sous tension à ce moment-là. En soudage semi-automatique ou automatique, le fil, le dévidoir, le logement des galets d'entraînement et les pièces métalliques en contact avec le fil de soudage sont sous tension. Des matériels mal installés ou mal mis à la terre présentent un danger.

- Ne jamais toucher les pièces électriques sous tension.
- Porter des gants et des vêtements de protection secs ne comportant pas de trous.
- S'isoler de la pièce et de la terre au moyen de tapis ou d'autres moyens isolants suffisamment grands pour empêcher le contact physique éventuel avec la pièce ou la terre.
- Ne pas se servir de source électrique à courant électrique dans les zones humides, dans les endroits confinés ou là où on risque de tomber.
- Se servir d'une source électrique à courant électrique UNIQUEMENT si le procédé de soudage le demande.
- Si l'utilisation d'une source électrique à courant électrique s'avère nécessaire, se servir de la fonction de télécommande si l'appareil en est équipé.
- Des précautions de sécurité supplémentaires sont requises dans des environnements à risque comme: les endroits humides ou lorsque l'on porte des vêtements mouillés; sur des structures métalliques au sol, grillages et échafaudages; dans des positions assises, à genoux et allongées; ou quand il y a un risque important de contact accidentel avec la pièce ou le sol. Dans ces cas utiliser les appareils suivants dans l'ordre de préférence: 1) un poste à souder DC semi-automatique de type CV (MIG/MAG), 2) un poste à souder manuel (électrode enrobée) DC, 3) un poste à souder

manuel AC avec tension à vide réduite. Dans la plupart des cas, un poste courant continu de type CV est recommandé. Et, ne pas travailler seul!

- Couper l'alimentation ou arrêter le moteur avant de procéder à l'installation, à la réparation ou à l'entretien de l'appareil. Déverrouiller l'alimentation selon la norme OSHA 29 CFR 1910.147 (voir normes de sécurité).
- Installer et mettre à la terre correctement cet appareil conformément à son manuel d'utilisation et aux codes nationaux, provinciaux et municipaux.
- Toujours vérifier la terre du cordon d'alimentation – Vérifier et s'assurer que le fil de terre du cordon d'alimentation est bien raccordé à la borne de terre du sectionneur ou que la fiche du cordon est raccordée à une prise correctement mise à la terre.
- En effectuant les raccordements d'entrée fixer d'abord le conducteur de mise à la terre approprié et contre-vérifier les connexions.
- Les câbles doivent être exempts d'humidité, d'huile et de graisse; protégez-les contre les étincelles et les pièces métalliques chaudes.
- Vérifier fréquemment le cordon d'alimentation pour voir s'il n'est pas endommagé ou dénudé – remplacer le cordon immédiatement s'il est endommagé – un câble dénudé peut provoquer une électrocution.
- Mettre l'appareil hors tension quand on ne l'utilise pas.
- Ne pas utiliser des câbles usés, endommagés, de grosseur insuffisante ou mal épissés.
- Ne pas enrouler les câbles autour du corps.
- Si la pièce soudée doit être mise à la terre, le faire directement avec un câble distinct – ne pas utiliser le connecteur de pièce ou le câble de retour.
- Ne pas toucher l'électrode quand on est en contact avec la pièce, la terre ou une électrode provenant d'une autre machine.
- Ne pas toucher des porte électrodes connectés à deux machines en même temps à cause de la présence d'une tension à vide doublée.
- N'utiliser qu'un matériel en bon état. Réparer ou remplacer sur-le-champ les pièces endommagées. Entretien l'appareil conformément à ce manuel.
- Porter un harnais de sécurité quand on travaille en hauteur.
- Maintenir solidement en place tous les panneaux et capots.
- Fixer le câble de retour de façon à obtenir un bon contact métal-métal avec la pièce à souder ou la table de travail, le plus près possible de la soudure.
- Isoler la pince de masse quand pas mis à la pièce pour éviter le contact avec tout objet métallique.

Une tension DC importante subsiste à l'intérieur des onduleurs après avoir coupé l'alimentation.

- Couper l'alimentation du poste et décharger les condensateurs d'entrée comme indiqué dans la Section Maintenance avant de toucher des composants.

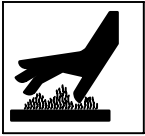

DES PIÈCES CHAUDES peuvent provoquer des brûlures graves.

- Ne pas toucher à mains nues les parties chaudes.
- Prévoir une période de refroidissement avant de travailler à l'équipement.
- Ne pas toucher aux pièces chaudes, utiliser les outils recommandés et porter des gants de soudage et des vêtements épais pour éviter les brûlures.

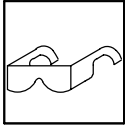

DES PIÈCES DE METAL ou DES SALETES peuvent provoquer des blessures dans les yeux.

- Le soudage, l'écaillage, le passage de la pièce à la brosse en fil de fer, et le meulage génèrent des étincelles et des particules métalliques volantes. Pendant la période de refroidissement des soudures, elles risquent de projeter du laitier.
- Porter des lunettes de sécurité avec écrans latéraux ou un écran facial.



LES FUMÉES ET LES GAZ peuvent être dangereux.

Le soudage génère des fumées et des gaz. Leur inhalation peut être dangereux pour votre santé.

- Eloigner votre tête des fumées. Ne pas respirer les fumées.
- À l'intérieur, ventiler la zone et/ou utiliser une ventilation forcée au niveau de l'arc pour l'évacuation des fumées et des gaz de soudage.
- Si la ventilation est médiocre, porter un respirateur anti-vapeurs approuvé.
- Lire et comprendre les spécifications de sécurité des matériaux (MSDS) et les instructions du fabricant concernant les métaux, les consommables, les revêtements, les nettoyants et les dégraissateurs.
- Travailler dans un espace fermé seulement s'il est bien ventilé ou en portant un respirateur à alimentation d'air. Demander toujours à un surveillant dûment formé de se tenir à proximité. Des fumées et des gaz de soudage peuvent déplacer l'air et abaisser le niveau d'oxygène provoquant des blessures ou des accidents mortels. S'assurer que l'air de respiration ne présente aucun danger.
- Ne pas souder dans des endroits situés à proximité d'opérations de dégraissage, de nettoyage ou de pulvérisation. La chaleur et les rayons de l'arc peuvent réagir en présence de vapeurs et former des gaz hautement toxiques et irritants.
- Ne pas souder des métaux munis d'un revêtement, tels que l'acier galvanisé, plaqué en plomb ou au cadmium à moins que le revêtement n'ait été enlevé dans la zone de soudure, que l'endroit soit bien ventilé, et en portant un respirateur à alimentation d'air. Les revêtements et tous les métaux renfermant ces éléments peuvent dégager des fumées toxiques en cas de soudage.



LES ACCUMULATIONS DE GAZ risquent de provoquer des blessures ou même la mort.

- Fermer l'alimentation du gaz protecteur en cas de non utilisation.
- Veiller toujours à bien aérer les espaces confinés ou se servir d'un respirateur d'adduction d'air homologué.

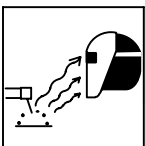

LES RAYONS DE L'ARC peuvent provoquer des brûlures dans les yeux et sur la peau.

Le rayonnement de l'arc du procédé de soudage génère des rayons visibles et invisibles intense (ultraviolets et infrarouges) susceptibles de provoquer des brûlures dans les yeux et sur la peau. Des étincelles sont projetées pendant le soudage.

- Porter un casque de soudage approuvé muni de verres filtrants approprié pour protéger visage et yeux pendant le soudage (voir ANSI Z49.1 et Z87.1 énuméré dans les normes de sécurité).
- Porter des lunettes de sécurité avec écrans latéraux même sous votre casque.
- Avoir recours à des écrans protecteurs ou à des rideaux pour protéger les autres contre les rayonnements les éblouissements et les étincelles ; prévenir toute personne sur les lieux de ne pas regarder l'arc.
- Porter des vêtements confectionnés avec des matières résistantes et ignifuges (cuir, coton lourd ou laine) et des bottes de protection.



LE SOUDAGE peut provoquer un incendie ou une explosion.

Le soudage effectué sur des conteneurs fermés tel que des réservoirs, tambours ou des conduites peut provoquer leur éclatement. Des étincelles peuvent être projetées de l'arc de soudure. La projection d'étincelles, des pièces chaudes et des équipements chauds peut provoquer des incendies et des brûlures. Le contact accidentel de l'électrode avec des objets métalliques peut provoquer des étincelles, une explosion, un surchauffement ou un incendie. Avant de commencer le soudage, vérifier et s'assurer que l'endroit ne présente pas de danger.

- Déplacer toutes les substances inflammables à une distance de 10,7 m de l'arc de soudage. En cas d'impossibilité les recouvrir soigneusement avec des protections homologués.
- Ne pas souder dans un endroit où des étincelles peuvent tomber sur des substances inflammables.
- Se protéger et d'autres personnes de la projection d'étincelles et de métal chaud.
- Des étincelles et des matériaux chauds du soudage peuvent facilement passer dans d'autres zones en traversant de petites fissures et des ouvertures.
- Surveiller tout déclenchement d'incendie et tenir un extincteur à proximité.
- Le soudage effectué sur un plafond, plancher, paroi ou séparation peut déclencher un incendie de l'autre côté.
- Ne pas effectuer le soudage sur des conteneurs fermés tels que des réservoirs, tambours, ou conduites, à moins qu'ils n'aient été préparés correctement conformément à AWS F4.1 (voir les normes de sécurité).
- Ne soudez pas si l'air ambiant est chargé de particules, gaz, ou vapeurs inflammables (vapeur d'essence, par exemple).
- Brancher le câble de masse sur la pièce la plus près possible de la zone de soudage pour éviter le transport du courant sur une longue distance par des chemins inconnus éventuels en provoquant des risques d'électrocution, d'étincelles et d'incendie.
- Ne pas utiliser le poste de soudage pour dégeler des conduites gelées.
- En cas de non utilisation, enlever la baguette d'électrode du porte-électrode ou couper le fil à la pointe de contact.
- Porter des vêtements de protection dépourvus d'huile tels que des gants en cuir, une chemise en matériau lourd, des pantalons sans revers, des chaussures hautes et un couvre chef.
- Avant de souder, retirer toute substance combustible de vos poches telles qu'un allumeur au butane ou des allumettes.
- Une fois le travail achevé, assurez-vous qu'il ne reste aucune trace d'étincelles incandescentes ni de flammes.
- Utiliser exclusivement des fusibles ou coupe-circuits appropriés. Ne pas augmenter leur puissance; ne pas les ponter.
- Suivre les recommandations dans OSHA 1910.252(a)(2)(iv) et NFPA 51B pour les travaux à chaud et avoir de la surveillance et un extincteur à proximité.

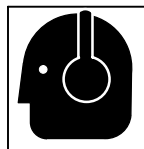

LE BRUIT peut affecter l'ouïe.

Le bruit des processus et des équipements peut affecter l'ouïe.

- Porter des protections approuvées pour les oreilles si le niveau sonore est trop élevé.



LES CHAMPS MAGNETIQUES peuvent affecter des implants médicaux.

- Porteur de simulateur cardiaque ou autre implants médicaux, rester à distance.
- Les porteurs d'implants doivent d'abord consulter leur médecin avant de s'approcher des opérations de soudage à l'arc, de soudage par points, de gougeage, du coupage plasma ou de chauffage par induction.

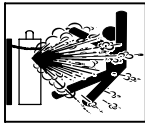

Si des BOUTEILLES sont endommagées, elles pourront exploser.

Des bouteilles de gaz protecteur contiennent du gaz sous haute pression. Si une bouteille est endommagée, elle peut exploser. Du fait que les bouteilles de gaz forment normalement partie du procédé de soudage, les manipuler avec précaution.

- Protéger les bouteilles de gaz comprimé d'une chaleur excessive, des chocs mécaniques, des dommages physiques, du laitier, des flammes ouvertes, des étincelles et des arcs.

- Placer les bouteilles debout en les fixant dans un support stationnaire ou dans un porte-bouteilles pour les empêcher de tomber ou de se renverser.
- Tenir les bouteilles éloignées des circuits de soudage ou autres circuits électriques.
- Ne jamais placer une torche de soudage sur une bouteille à gaz.
- Une électrode de soudage ne doit jamais entrer en contact avec une bouteille.
- Ne jamais souder une bouteille pressurisée – risque d'explosion.
- Utiliser seulement des bouteilles de gaz protecteur, régulateurs, tuyaux et raccords convenables pour cette application spécifique; les maintenir ainsi que les éléments associés en bon état.
- Ne pas tenir la tête en face de la sortie en ouvrant la soupape de la bouteille.
- Maintenir le chapeau de protection sur la soupape, sauf en cas d'utilisation ou de branchement de la bouteille.
- Utiliser les équipements corrects, les bonnes procédures et suffisamment de personnes pour soulever et déplacer les bouteilles.
- Lire et suivre les instructions sur les bouteilles de gaz comprimé, l'équipement connexe et le dépliant P-1 de la CGA (Compressed Gas Association) mentionné dans les principales normes de sécurité.

2-3. Dangers existant en relation avec le moteur

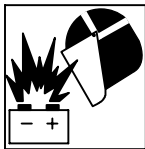

L'EXPLOSION DE LA BATTERIE peut RENDRE AVEUGLE.

- Toujours porter une protection faciale, des gants en caoutchouc et vêtements de protection lors d'une intervention sur la batterie.
- Arrêter le moteur avant de débrancher ou de brancher les câbles de batterie.
- Eviter de provoquer des étincelles avec les outils en travaillant sur la batterie.
- Ne pas utiliser le poste de soudage pour charger les batteries ou des véhicules de démarrage rapide.
- Observer la polarité correcte (+ et -) sur les batteries.
- Débrancher le câble négatif (-) en premier lieu. Le rebrancher en dernier lieu.

- Seules des personnes qualifiées sont autorisées à enlever les portes, panneaux, recouvrements ou dispositifs de protection pour effectuer, s'il y a lieu, des travaux d'entretien et de dépannage.
- Pour empêcher tout démarrage accidentel pendant les travaux d'entretien, débrancher le câble négatif (-) de batterie de la borne.
- Ne pas approcher les mains, cheveux, vêtements lâches et outils des organes mobiles.
- Remettre en place les panneaux ou les dispositifs de protection et fermer les portes à la fin des travaux d'entretien et avant de faire démarrer le moteur.
- Avant d'intervenir, déposer les bougies ou injecteurs pour éviter la mise en route accidentelle du moteur.
- Bloquer le volant moteur pour éviter sa rotation lors d'une intervention sur le générateur.



LE CARBURANT MOTEUR peut provoquer un incendie ou une explosion.

- Arrêter le moteur avant de vérifier le niveau de carburant ou de faire le plein.
- Ne pas faire le plein en fumant ou proche d'une source d'étincelles ou d'une flamme nue.
- Ne pas faire le plein de carburant à ras bord; prévoir de l'espace pour son expansion.
- Faire attention de ne pas renverser de carburant. Nettoyer tout carburant renversé avant de faire démarrer le moteur.
- Jeter les chiffons dans un récipient ignifuge.
- Toujours garder le pistolet en contact avec le réservoir lors du remplissage.



DES PIÈCES CHAUDES peuvent provoquer des brûlures graves.

- Ne pas toucher à mains nues les parties chaudes.
- Prévoir une période de refroidissement avant de travailler à l'équipement.
- Ne pas toucher aux pièces chaudes, utiliser les outils recommandés et porter des gants de soudage et des vêtements épais pour éviter les brûlures.

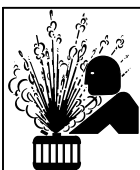

LA VAPEUR ET LE LIQUIDE DE REFROIDISSEMENT CHAUD peuvent provoquer des brûlures.

- Il est préférable de vérifier le liquide de refroidissement une fois le moteur refroidi pour éviter de se brûler.
- Toujours vérifier le niveau de liquide de refroidissement dans le vase d'expansion (si présent), et non dans le radiateur (sauf si précisé autrement dans la section maintenance du manuel du moteur).
- Si le moteur est chaud et que le liquide doit être vérifié, opérer comme suivant.
- Mettre des lunettes de sécurité et des gants, placer un torchon sur le bouchon du radiateur.
- Dévisser le bouchon légèrement et laisser la vapeur s'échapper avant d'enlever le bouchon.



DES ORGANES MOBILES peuvent provoquer des blessures.

- Ne pas approcher les mains des ventilateurs, courroies et autres pièces en mouvement.
- Maintenir fermés et fixement en place les portes, panneaux, recouvrements et dispositifs de protection.
- Arrêter le moteur avant d'installer ou brancher l'appareil.



L'utilisation d'un groupe autonome à l'intérieur PEUT VOUS TUER EN QUELQUES MINUTES.

- Les fumées d'un groupe autonome contient du monoxyde de carbone. C'est un poison invisible et inodore.
- JAMAIS utiliser dans une maison ou garage, même avec les portes et fenêtres ouvertes.
- Uniquement utiliser à l'EXTERIEUR, loin des portes, fenêtres et bouches aération.



L'ACIDE DE LA BATTERIE peut provoquer des brûlures dans les YEUX et sur la PEAU.

- Ne pas renverser la batterie.
- Remplacer une batterie endommagée.
- Rincer immédiatement les yeux et la peau à l'eau.



LA CHALEUR DU MOTEUR peut provoquer un incendie.

- Ne pas placer l'appareil sur, au-dessus ou à proximité de surfaces inflammables.
- Tenir à distance les produits inflammables de l'échappement.



LES ÉTINCELLES À L'ÉCHAPPEMENT peuvent provoquer un incendie.

- Empêcher les étincelles d'échappement du moteur de provoquer un incendie.
- Utiliser uniquement un pare-étincelles approuvé – voir codes en vigueur.

2-4. Dangers liés à l'air comprimé



RESPIRER L'AIR COMPRIMÉ peut provoquer des blessures graves ou causer la mort.

- Ne pas utiliser l'air comprimé pour respirer.
- Utiliser l'air comprimé seulement pour le coupage, gougeage et les outils pneumatiques.

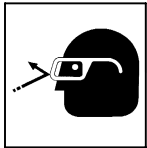

L'AIR COMPRIMÉ peut provoquer des blessures.

- Porter des lunettes de sécurité approuvées.
- Ne pas diriger le jet d'air vers d'autres ou soi-même.

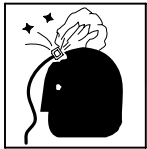

L'AIR COMPRIE EMMAGASINE ET DES TUYAUX SOUS PRESSON peuvent provoquer des blessures.

- Relâcher la pression d'air de l'outillage ou du système avant d'effectuer la maintenance, avant de changer ou de rajouter des éléments ou avant d'ouvrir la purge ou le bouchon de remplissage d'huile.



Le METAL CHAUD lors du coupage et gougeage plasma peut provoquer un incendie ou une explosion.

- Ne pas couper ou gouger à proximité de produits inflammables.
- Surveillez et garder un extincteur à proximité.



DES PIÈCES CHAUDES peuvent provoquer des brûlures et blessures.

- Ne pas toucher le compresseur ou d'autres éléments du circuit air comprimé chauds.
- Laisser l'ensemble se refroidir avant de toucher ou d'effectuer la maintenance.

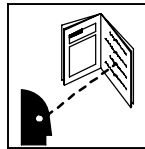

LIRE LES INSTRUCTIONS.

- Lisez le manuel d'instructions avant l'utilisation ou la maintenance de l'appareil.
- Arrêter le moteur et relâcher la pression avant d'effectuer la maintenance.
- N'utiliser que les pièces de rechange recommandées par le constructeur.

2-5. Dangers supplémentaires en relation avec l'installation, le fonctionnement et la maintenance



Risque D'INCENDIE OU D'EXPLOSION.

- Ne pas placer l'appareil sur, au-dessus ou à proximité de surfaces inflammables.
- Ne pas installer l'appareil à proximité de produits inflammables.
- Ne pas surcharger l'installation électrique – s'assurer que l'alimentation est correctement dimensionnée et protégée avant de mettre l'appareil en service.

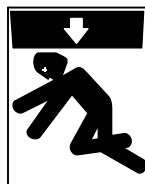

LA CHUTE DE L'APPAREIL peut blesser.

- Utiliser l'anneau de levage pour lever l'appareil et les accessoires correctement installés seuls, PAS les bouteilles de gaz. Ne pas dépasser le poids nominal maximal de l'œilleton (voir les spécifications).
- Ne lever et ne soutenir l'appareil qu'avec de l'équipement approprié et en suivant les procédures adéquates.
- En utilisant des fourches de levage pour déplacer l'unité, s'assurer que les fourches sont suffisamment longues pour dépasser du côté opposé de l'appareil.

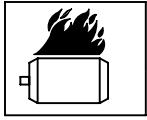

LE SURCHAUFFEMENT peut endommager le moteur électrique.

- Arrêter ou déconnecter l'équipement avant de démarrer ou d'arrêter le moteur.
- Ne pas laisser tourner le moteur trop lentement sous risque d'endommager le moteur électrique à cause d'une tension et d'une fréquence trop faibles.
- Ne pas brancher de moteur de 50 ou de 60 Hz à la prise de 100 Hz, s'il y a lieu.

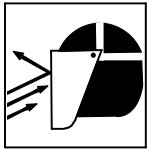

LES ÉTINCELLES VOLANTES risquent de provoquer des blessures.

- Porter un écran facial pour protéger le visage et les yeux.
- Affûter l'électrode au tungstène uniquement à la meuleuse dotée de protecteurs. Cette manœuvre est à exécuter dans un endroit sûr lorsque l'on porte l'équipement homologué de protection du visage, des mains et du corps.
- Les étincelles risquent de causer un incendie – éloigner toute substance inflammable.



DES ORGANES MOBILES peuvent provoquer des blessures.

- Ne pas s'approcher des organes mobiles.
- Ne pas s'approcher des points de coincement tels que des rouleaux de commande.



LES FILS DE SOUDAGE peuvent provoquer des blessures.

- Ne pas appuyer sur la gâchette avant d'en avoir reçu l'instruction.
- Ne pas diriger le pistolet vers soi, d'autres personnes ou toute pièce mécanique en engageant le fil de soudage.

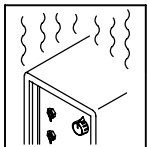

L'EMPLOI EXCESSIF peut SURCHAUFFER L'ÉQUIPEMENT.

- Laisser l'équipement refroidir ; respecter le facteur de marche nominal.
- Réduire le courant ou le facteur de marche avant de poursuivre le soudage.
- Ne pas obstruer les passages d'air du poste.

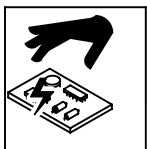

LES CHARGES ÉLECTROSTATIQUES peuvent endommager les circuits imprimés.

- Établir la connexion avec la barrette de terre avant de manipuler des cartes ou des pièces.
- Utiliser des pochettes et des boîtes antistatiques pour stocker, déplacer ou expédier des cartes de circuits imprimés.

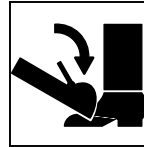

UNE REMORQUE QUI BASCULE peut entraîner des blessures.

- Utiliser les supports de la remorque ou des blocs pour soutenir le poids.
- Installer convenablement le poste sur la remorque comme indiqué dans le manuel s'y rapportant.

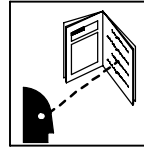

LIRE LES INSTRUCTIONS.

- Lisez le manuel d'instructions avant l'utilisation ou la maintenance de l'appareil.
- N'utiliser que les pièces de rechange recommandées par le constructeur.
- Effectuer la maintenance et le service du moteur et du compresseur d'air suivant les instructions dans ce manuel ou le manuel du moteur/compresseur (si applicable).

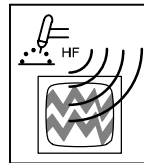

LE RAYONNEMENT HAUTE FRÉQUENCE (H.F.) risque de provoquer des interférences.

- Le rayonnement haute fréquence (H.F.) peut provoquer des interférences avec les équipements de radio-navigation et de communication, les services de sécurité et les ordinateurs.
- Demander seulement à des personnes qualifiées familiarisées avec des équipements électroniques de faire fonctionner l'installation.
- L'utilisateur est tenu de faire corriger rapidement par un électricien qualifié les interférences résultant de l'installation.
- Si le FCC signale des interférences, arrêter immédiatement l'appareil.
- Effectuer régulièrement le contrôle et l'entretien de l'installation.
- Maintenir soigneusement fermés les portes et les panneaux des sources de haute fréquence, maintenir les éclateurs à une distance correcte et utiliser une terre et un blindage pour réduire les interférences éventuelles.

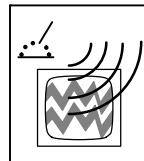

LE SOUDAGE À L'ARC risque de provoquer des interférences.

- L'énergie électromagnétique risque de provoquer des interférences pour l'équipement électronique sensible tel que les ordinateurs et l'équipement commandé par ordinateur tel que les robots.
- Veiller à ce que tout l'équipement de la zone de soudage soit compatible électromagnétiquement.
- Pour réduire la possibilité d'interférence, maintenir les câbles de soudage aussi courts que possible, les grouper, et les poser aussi bas que possible (ex. par terre).
- Veiller à souder à une distance de 100 mètres de tout équipement électronique sensible.
- Veiller à ce que ce poste de soudage soit posé et mis à la terre conformément à ce mode d'emploi.
- En cas d'interférences après avoir pris les mesures précédentes, il incombe à l'utilisateur de prendre des mesures supplémentaires telles que le déplacement du poste, l'utilisation de câbles blindés, l'utilisation de filtres de ligne ou la pose de protecteurs dans la zone de travail.

2-6. Proposition californienne 65 Avertissements

! Les équipements de soudage et de coupage produisent des fumées et des gaz qui contiennent des produits chimiques dont l'État de Californie reconnaît qu'ils provoquent des malformations congénitales et, dans certains cas, des cancers. (Code de santé et de sécurité de Californie, chapitre 25249.5 et suivants)

! Les batteries, les bornes et autres accessoires contiennent du plomb et des composés à base de plomb, produits chimiques dont l'État de Californie reconnaît qu'ils provoquent des cancers et des malformations congénitales ou autres problèmes de procréation. Se laver les mains après manipulation.

Pour les moteurs à essence :

! Les gaz d'échappement des moteurs contiennent des produits chimiques dont l'État de Californie reconnaît qu'ils provoquent des cancers et des malformations congénitales ou autres problèmes de procréation.

Pour les moteurs diesel :

! Les gaz d'échappement des moteurs diesel et certains de leurs composants sont reconnus par l'État de Californie comme provoquant des cancers et des malformations congénitales ou autres problèmes de procréation.

2-7. Principales normes de sécurité

Safety in Welding, Cutting, and Allied Processes, ANSI Standard Z49.1, de Global Engineering Documents (téléphone : 1-877-413-5184, site Internet : www.global.ih.com).

Recommended Safe Practices for the Preparation for Welding and Cutting of Containers and Piping, American Welding Society Standard AWS F4.1 de Global Engineering Documents (téléphone : 1-877-413-5184, site Internet : www.global.ih.com).

National Electrical Code, NFPA Standard 70, de National Fire Protection Association, P.O. Box 9101, Quincy, MA 02269-9101 (téléphone : 617-770-3000, site Internet : www.nfpa.org).

Safe Handling of Compressed Gases in Cylinders, CGA Pamphlet P-1, de Compressed Gas Association, 4221 Walney Road, 5th Floor, Chantilly, VA 20151 (téléphone : 703-788-2700, site Internet : www.cganet.com).

Code for Safety in Welding and Cutting, CSA Standard W117.2, de Canadian Standards Association, 5060 Mississauga, Ontario, Canada

L4W 5NS (téléphone : 800-463-6727 ou à Toronto 416-747-4044, site Internet : www.csa-international.org).

Safe Practice For Occupational And Educational Eye And Face Protection, ANSI Standard Z87.1, de American National Standards Institute, 11 West 43rd Street, New York, NY 10036-8002 (téléphone : 212-642-4900, site Internet : www.ansi.org).

Standard for Fire Prevention During Welding, Cutting, and Other Hot Work, NFPA Standard 51B, de National Fire Protection Association, P.O. Box 9101, Quincy, MA 02269-9101 (téléphone : 617-770-3000, site Internet : www.nfpa.org).

OSHA, Occupational Safety and Health Standards for General Industry, Title 29, Code of Federal Regulations (CFR), Part 1910, Subpart Q, and Part 1926, Subpart J, de U.S. Government Printing Office, Superintendent of Documents, P.O. Box 371954, Pittsburgh, PA 15250-7954 (téléphone : 1-866-512-1800) (il y a 10 bureaux régionaux--le téléphone de la région 5, Chicago, est 312-353-2220, site Internet : www.osha.gov).

2-8. Information EMF

Considérations sur le soudage et les effets de basse fréquence et des champs magnétiques et électriques.

Le courant de soudage, pendant son passage dans les câbles de soudage, causera des champs électromagnétiques. Il y a eu et il y a encore un certain souci à propos de tels champs. Cependant, après avoir examiné plus de 500 études qui ont été faites pendant une période de recherche de 17 ans, un comité spécial ruban bleu du National Research Council a conclu : « L'accumulation de preuves, suivant le jugement du comité, n'a pas démontré que l'exposition aux champs magnétiques et champs électriques à haute fréquence représente un risque à la santé humaine ». Toutefois, des études sont toujours en cours et les preuves continuent à être examinées. En attendant que les conclusions finales de la recherche soient établies, il vous serait souhaitable de réduire votre exposition aux champs électromagnétiques pendant le soudage ou le coupage.

Pour réduire les champs magnétiques sur le poste de travail, appliquer les procédures suivantes :

1. Garder les câbles ensemble, les torsader, les scotcher, ou les recouvrir d'une housse.
2. Disposer les câbles d'un côté et à distance de l'opérateur.
3. Ne pas courber pas et ne pas entourer pas les câbles autour de votre corps.
4. Garder le poste de soudage et les câbles le plus loin possible de vous.
5. Connecter la pince sur la pièce aussi près que possible de la soudure.

En ce qui concerne les implants médicaux :

Les porteurs d'implants doivent d'abord consulter leur médecin avant de s'approcher des opérations de soudage à l'arc, de soudage par points, de gougeage, du coupage plasma ou de chauffage par induction. Si le médecin approuve, il est recommandé de suivre les procédures précédentes.

3-2. Manufacturer's Rating Labels

CC Models

IEC 60974-1						
	=	55A/22.2V to 450A/38V		55A/22V to 300A/32V (CE)		
		X	80%	100%	100%(CE)	
		I_2	450A	400A	300A	
$U_0 = 92V$	=	U_2	38V	36V	32V	
		55A/12.2V to 500A/30V		55A/12V to 300A/22V (CE)		
		X	40%	60%	100%	100%(CE)
$U_0 = 92V$	=	I_2	500A	450A	400A	300A
		U_2	30V	28V	26V	22V
		40A/21.6V to 375A/35V				
$U_0 = 92V$	=	X	40%	60%	100%	
		I_2	375A	335A	300A	
		U_2	35V	33.4V	32V	
	~	40A/11.6V to 375A/25V				
		X	40%	60%	100%	
		I_2	375A	335A	300A	
$U_0 = 64V$	~	U_2	25V	23.4V	22V	
		n = 1800 min ⁻¹				
		n ₀ = 1850 min ⁻¹	n ₁ = 1235 min ⁻¹			
IP 23						
1 ~ 60 Hz	120/240V	4kVA	20/17A			
1 ~ 60 Hz	120/240V	4kVA	20/15A(CE)			

*Optional 215 073-C

CC/CV Models

ISO / IEC 60974-1					
	=	45A/21.8V		to	450A/38V
		X		60%	100%
		I_2		450A	400A
$U_0 = 92V$	=	U_2		38V	36V
		15A/11V		to	350A/24V
		X			100%
$U_0 = 48V$	=	I_2			350A
		U_2			24V
		20A/15V		to	450A/36.5V
$U_0 = 56V$	=	X		60%	100%
		I_2		450A	400A
		U_2		36.5V	34V
	~	25A/21V		to	375A/35V
		X	40%	60%	100%
		I_2	375A	335A	300A
$U_0 = 64V$	~	U_2	35V	33.4V	32V
		15A/10.6V		to	375A/25V
		X	40%	60%	100%
$U_0 = 34V$	~	I_2	375A	335A	300A
		U_2	25V	23.4V	22V
		n = 1800 min ⁻¹			
n ₀ = 1850 min ⁻¹	n ₁ = 1235 min ⁻¹				
IP 23					
1 ~ 60 Hz	120/240V	4kVA	20/17A		
*1 ~ 60 Hz	120/240V	12kVA	50/50A		
*3 ~ 60 Hz	240V	15kVA	38A		

*Optional 400/40/CV/215 208-B

CC Export Models

IEC 60974-1				
	=	55A/22V to 300A/32V		
		X		100%
		I_2		300A
$U_0 = 92V$	=	U_2		32V
		55A/12V to 300A/22V		
		X		100%
$U_0 = 92V$	=	I_2		300A
		U_2		22V
		n = 1800 min ⁻¹		
n ₀ = 1850 min ⁻¹	n ₁ = 1235 min ⁻¹			
IP 23				
1 ~ 60 Hz	120/240V	4kVA	20/15A	

232 346-B



















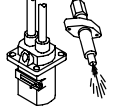
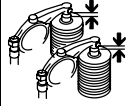







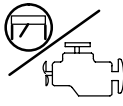





CC/CV Export Models

ISO / IEC 60974-1					
	=	45A/22V		to	430A/37V
		X		60%	100%
		I_2		430A	300A
$U_0 = 91V$	=	U_2		37V	32V
		20A/11V		to	300A/22V
		X			100%
$U_0 = 48V$	=	I_2			300A
		U_2			22V
		20A/15V		to	430A/36V
$U_0 = 56V$	=	X		60%	100%
		I_2		430A	300A
		U_2		36V	29V
	~	15A/11V		to	350A/24V
		X			60%
		I_2			300A
$U_0 = 34V$	~	U_2			32V
		n = 1800 min ⁻¹			
		n ₀ = 1850 min ⁻¹	n ₁ = 1235 min ⁻¹		
IP 23					
1 ~ 60 Hz	120/240V	4kVA	20/15A		

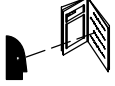
*Optional 209 782-A

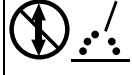
3-3. Symbols And Definitions

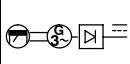
 Some symbols are found only on export products.

	Stop Engine		Fast (Run, Weld/Power)		Slow (Idle)		Start Engine
	Starting Aid		Battery (Engine)		Engine Oil Pressure		Engine Oil
	Check Injectors/Pump		Check Valve Clearance		Fuel		Protective Earth (Ground)
	Positive		Negative		Certified/Trained Mechanic		Welding Arc
A	Amperes	V	Volts		Panel/Local		Remote
	Engine		Air Temperature Or Engine Temperature		Output		Alternating Current
	Stick (SMAW) Welding		Constant Current (CC)		MIG (GMAW) Welding		TIG (GTAW)
	Time	h	Hours	s	Seconds		Single Phase
	Three Phase		Read Operator's Manual		Circuit Protector		Do Not Switch While Welding
	Electrode Connection		Work Connection		Engine-Driven, Three-Phase Alternator With Rectifier	Hz	Hertz
X	Duty Cycle	U₀	Rated No Load Voltage (Average)	U₂	Conventional Load Voltage	n	Rated Load Speed
n₁	Rated Idle Speed	n₀	Rated No Load Speed	I	Current	I₂	Rated Welding Current
	Contactor On						

SECTION 4 – SPECIFICATIONS

4-1. Weld, Power, And Engine Specifications

Welding Mode	Weld Output Range	Rated Welding Output	Maximum Open-Circuit Voltage	Generator Power Rating	Engine	Fuel Capacity
CC/DC	55 – 500 A (CC Models) 15 – 500 A (CC/CV Models)	Export Models: 300 A, 32 Volts DC, 100% Duty Cycle 430 A, 37 Volts DC, 60% Duty Cycle 300 A, 29 Volts DC (CV), 100% Duty Cycle 430 A, 36 Volts DC (CV), 60% Duty Cycle	95	Standard Single-Phase, 4 kVA/kW, 34/17 A, 120/240 V AC, 50/60 Hz Three-Phase Generator Option* Single-Phase/Three-Phase, 12/15 kVA/kW, 50/36A, 120/240 VAC, 60 Hz *In Addition To Standard 4 kVA/kW Generator Power	 Perkins Perkins 404-22 Water-Cooled, Four-Cylinder, 32.6 HP Diesel Engine	25 gal (95 L)
CV/DC (CC/CV Models Only)	14 – 40 V	Other Models: 400 A, 36 Volts DC, 100% Duty Cycle 450 A, 38 Volts DC, 60% Duty Cycle 500 A, 30 Volts DC (CC), 34 Volts DC (CV), 40% Duty Cycle	56			

4-2. Dimensions, Weights, And Operating Angles

Dimensions	
Height	60 in (1524 mm) (to top of muffler)
Width	28-1/2 in (724 mm) (mtg. brackets turned in)
	30-3/4 in (781 mm) (mtg. brackets turned out)
Depth	65-1/8 in (1654 mm)
A	65-1/8 in (1654 mm)
B*	56 in (1422 mm)
C*	46-1/2 in (1181)
D*	9-5/8 in (244 mm)
E	27-1/2 in (699 mm)
F	1 in (25 mm)
G	29-13/16 in (757 mm)
H	9/16 in (14 mm) Dia. 4 Holes
* With mounting brackets in center position. Dimensions vary with location of mounting brackets.	
Weight	
w/ Perkins 404-22	No fuel: 1600 lb (726 kg) W/fuel: 1775 lb (805 kg)
Lifting Eye Weight Rating: 2500 lb (1134 kg) Maximum	

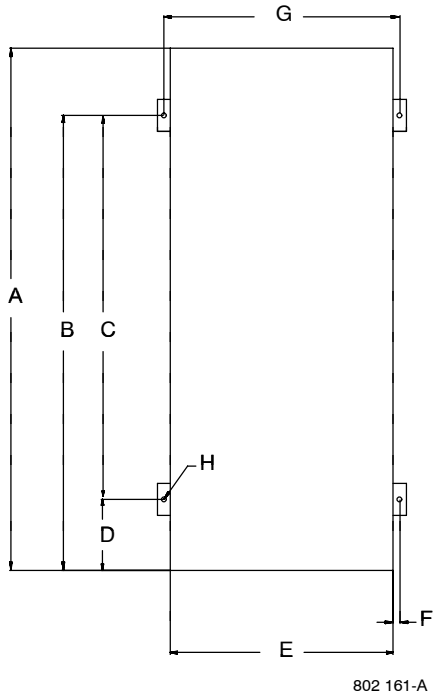



⚠ Do not exceed tilt angles or engine could be damaged or unit could tip.

⚠ Do not move or operate unit where it could tip.

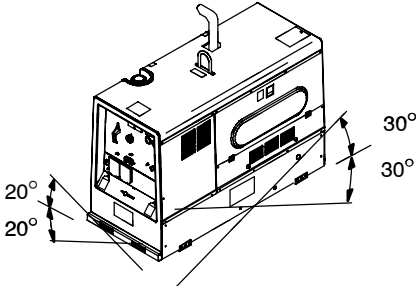

4-4. Volt-Ampere Curves For CC/CV Models

A. Stick Mode

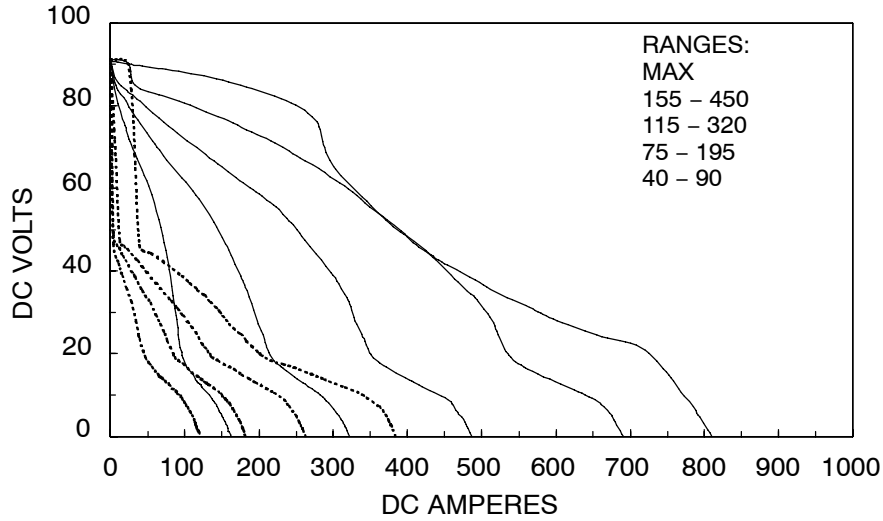

The volt-ampere curves show the minimum and maximum voltage and amperage output capabilities of the welding generator. Curves of all other settings fall between the curves shown.

B. MIG Mode

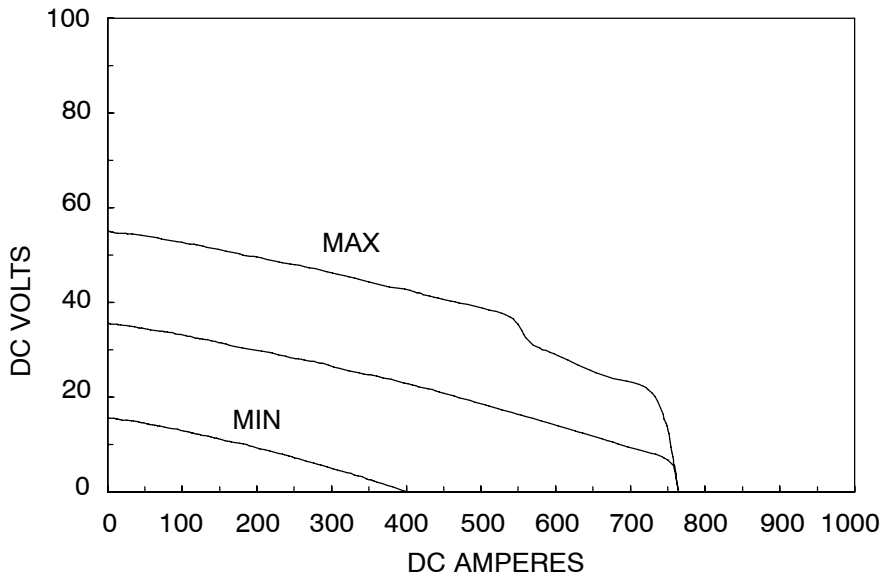

C. TIG Mode

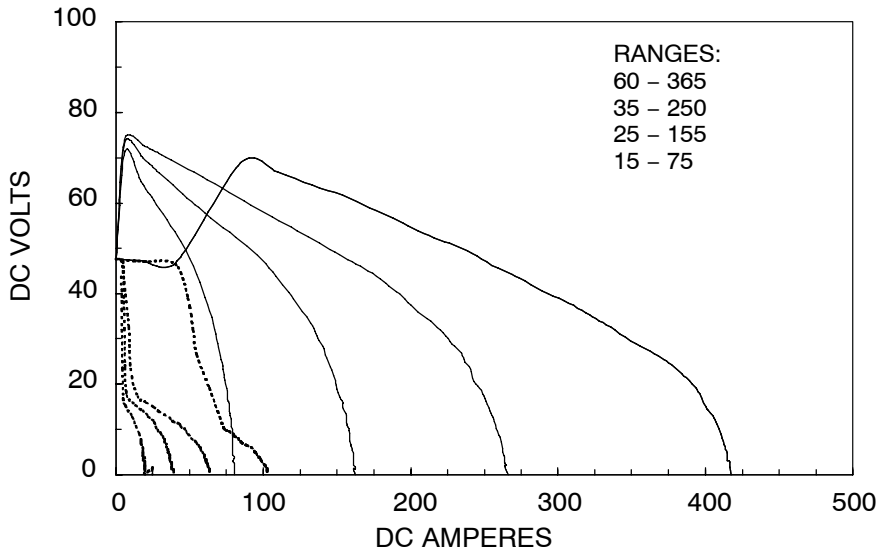

4-5. Fuel Consumption

The curve shows typical fuel use under weld or power loads.

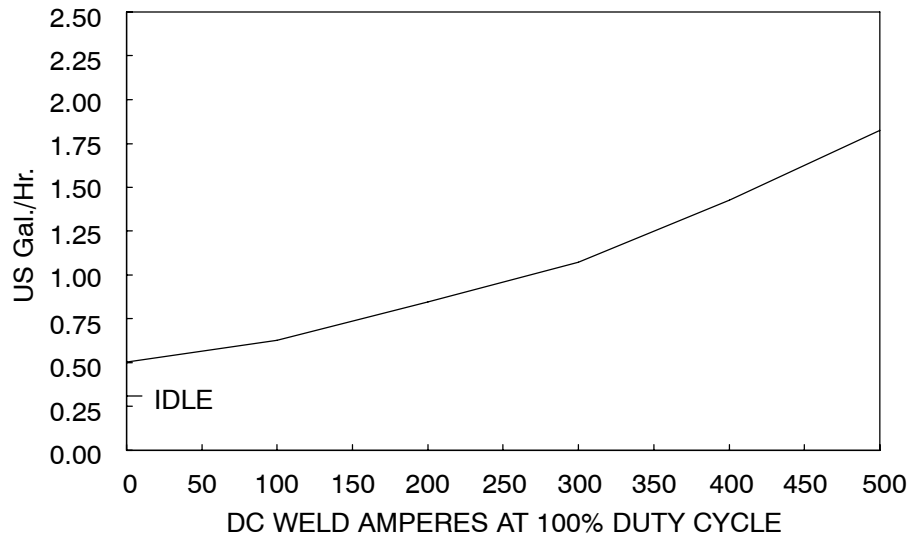

199 032-A

4-6. Duty Cycle And Overheating



100% Duty Cycle At 400 Amperes



Continuous Welding

Duty Cycle is percentage of 10 minutes that unit can weld at rated load without overheating.

NOTICE – Exceeding duty cycle can damage unit and void warranty.

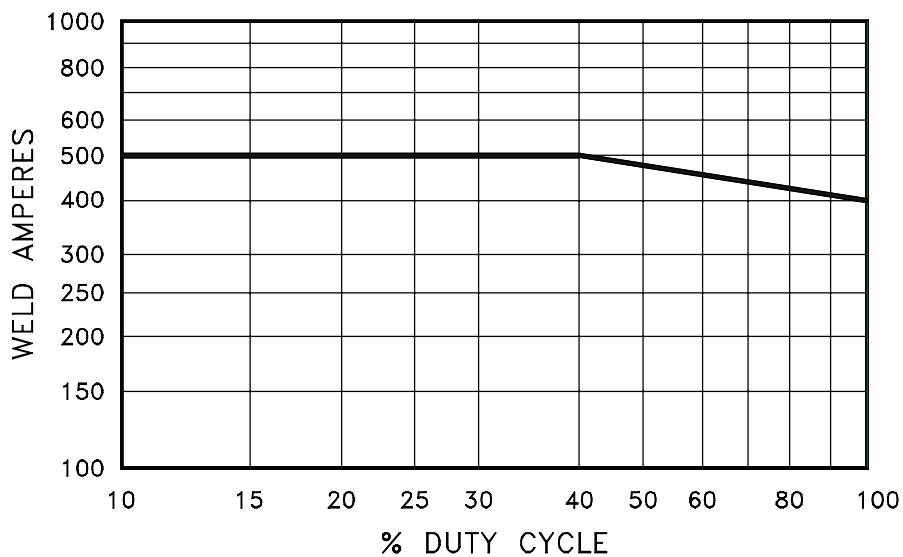

215 084-A

4-7. AC Generator Power Curve

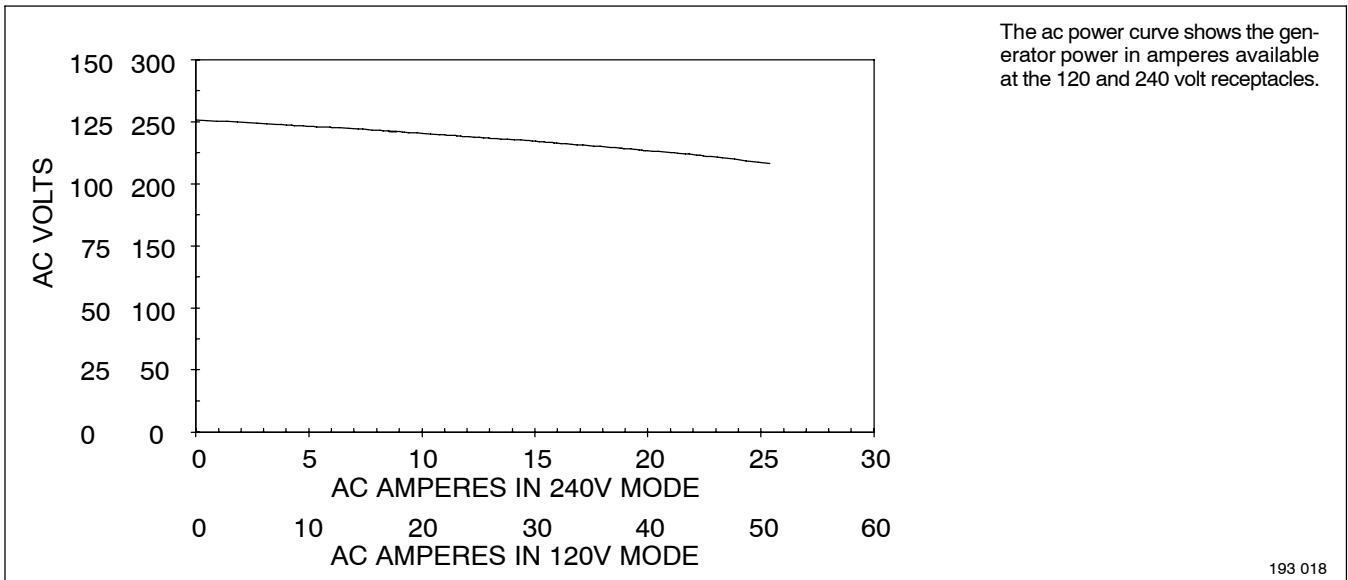

4-8. Optional Three-Phase Generator Curves

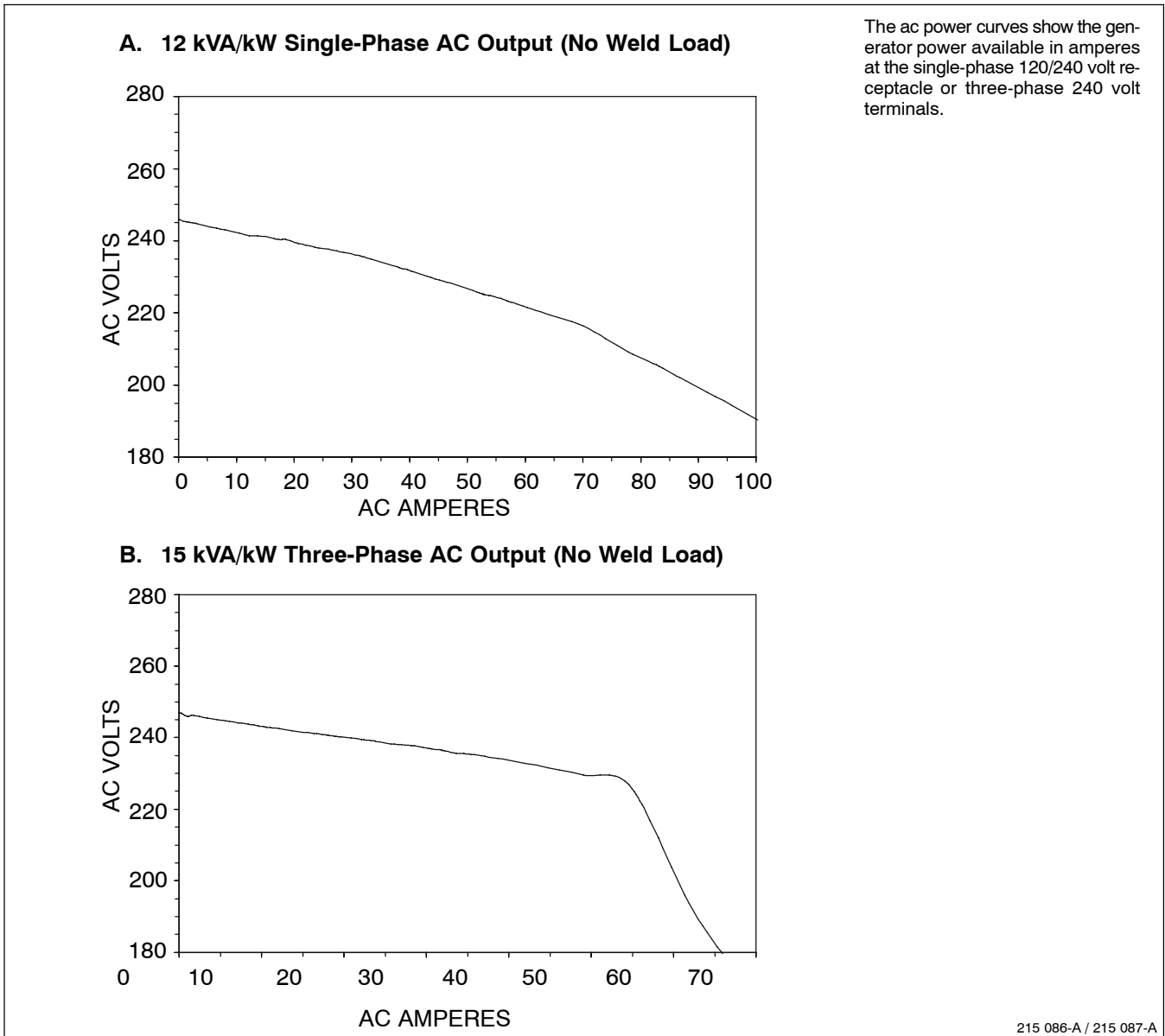

SECTION 5 – INSTALLATION

5-1. Installing Welding Generator

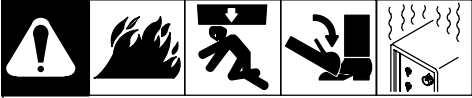

Movement

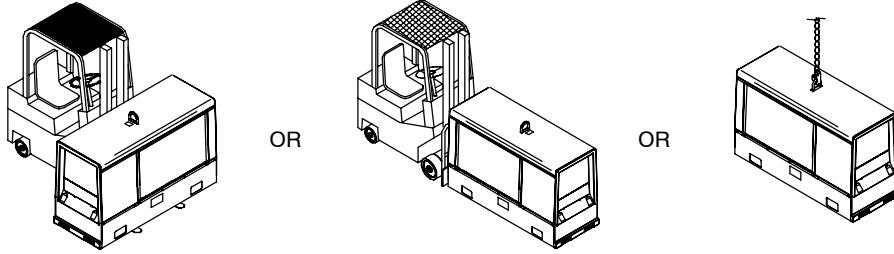

⚠ Always securely fasten welding generator onto transport vehicle or trailer and comply with all DOT and other applicable codes.

⚠ Always ground generator frame to vehicle frame to prevent electric shock and static electricity hazards.

⚠ If unit does not have GFCI receptacles, use GFCI-protected extension cord.

NOTICE – Do not install unit where air flow is restricted or engine may overheat.

Location/Airflow Clearance

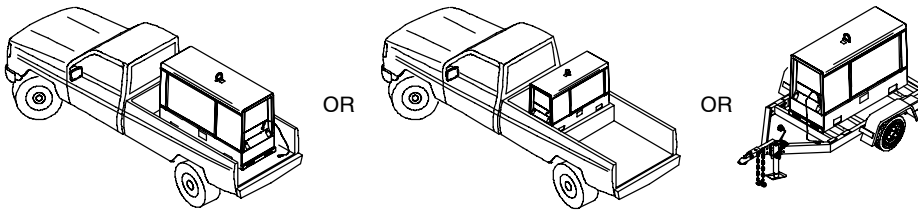

☞ See Section 4-2 for lifting eye rating.

☞ See Section 5-3 for mounting information.

Grounding:

- 1 Equipment Grounding Terminal (On Front Panel)
- 2 Grounding Cable (Not Supplied)
- 3 Metal Vehicle Frame

☞ Electrically bond generator frame to vehicle frame by metal-to-metal contact.

Connect cable from equipment ground terminal to metal vehicle frame. Use #10 AWG or larger insulated copper wire.

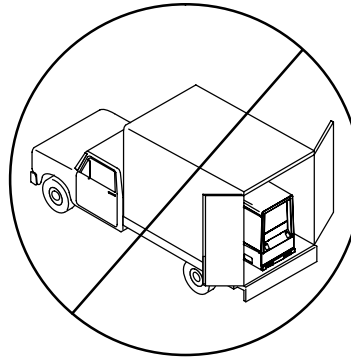
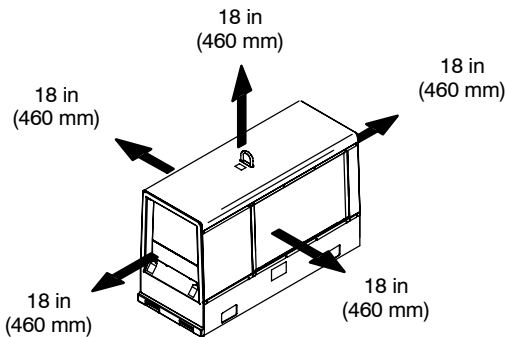

⚠ Bed liners, shipping skids, and some running gears insulate the welding generator from the vehicle frame. Always connect a ground wire from the generator equipment grounding terminal to bare metal on the vehicle frame as shown.

Grounding

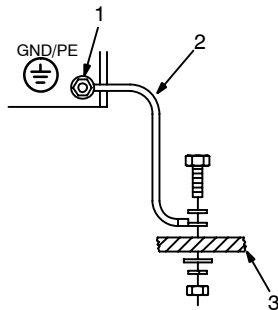

5-3. Mounting Welding Generator



Supporting The Unit

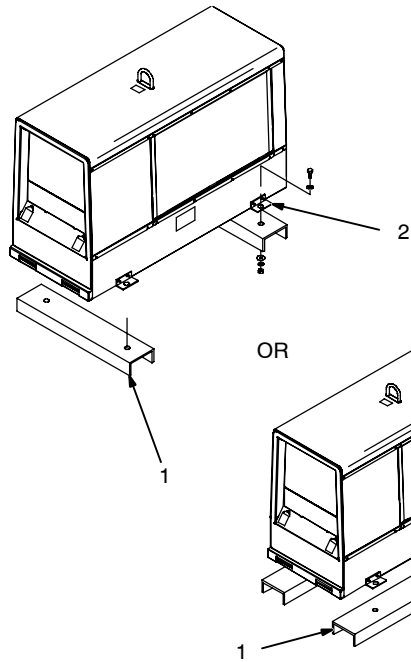
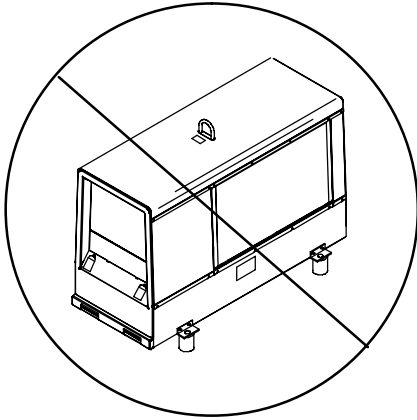

⚠ Do not weld on base. Welding on base can cause fuel tank fire or explosion. Weld only on the four mounting brackets or bolt unit down.

NOTICE – Do not mount unit by supporting the base only at the four mounting brackets. Use cross-supports to adequately support unit and prevent damage to base.

Mounting Surface:

1 Cross-Supports
2 Mounting Brackets (Supplied)
Mount unit on flat surface or use cross-supports to support base. Secure unit with mounting brackets.

3 1/2 in Bolt And Washer (Minimum – Not Supplied)
4 3/8-16 x 1 in Screws (Supplied)

To Bolt Unit In Place:

Remove hardware securing the four mounting brackets to the base. Reverse brackets and reattach to base with original hardware.

Mount unit to truck or trailer with 1/2 in (12 mm) or larger hardware (not supplied).

To Weld Unit In Place:

Weld unit to truck or trailer only at the four mounting brackets.

Using Mounting Brackets

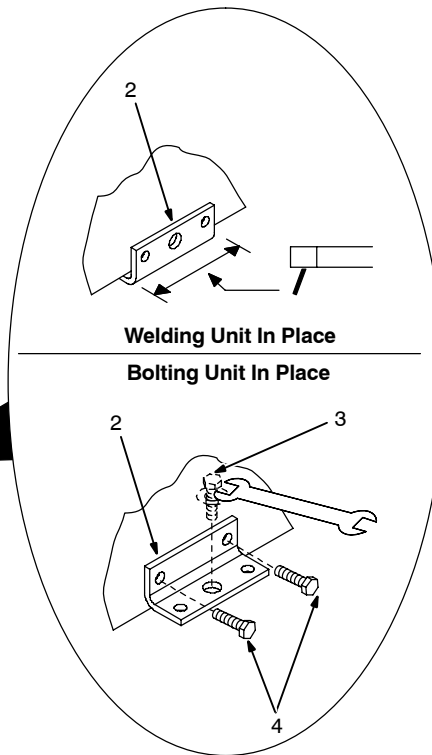
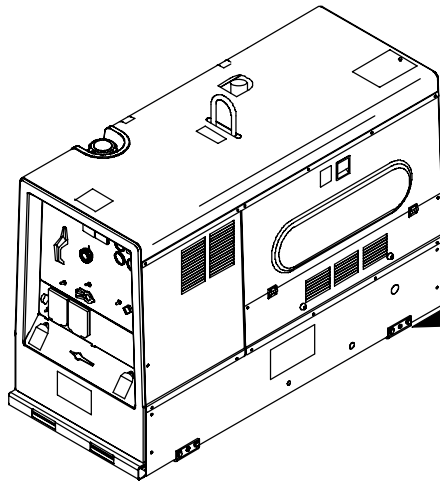

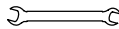
Tools Needed:
 9/16 in

install3 2007-046 803 274 / 200 864-A / 803 602

5-5. Activating The Dry Charge Battery (If Applicable)

1 Vent Caps

2 Sulfuric Acid Electrolyte (1.265 Specific Gravity)

3 Well

4 Battery Charger

5 A For 30 Minutes
OR
30 A For 12 Minutes

Tools Needed:

⚠ Always wear a face shield, rubber gloves and protective clothing when working on a battery.

Remove battery from unit.

⚠ Do not overfill battery cells.

Wait ten minutes and check electrolyte level. If necessary, add electrolyte to raise to proper level. Reinstall vent caps.

⚠ Read and follow all instructions supplied with battery charger.

Charge battery for 12 minutes at 30 amperes or 30 minutes at 5 amperes. Disconnect charging cables and install battery.

☞ When electrolyte is low, add only distilled water to cells to maintain proper level.

drybatt1 6/05 - S-0886

5-6. Connecting The Battery

⚠ Connect negative (-) cable last.

☞ Reinstall cover after connecting battery.

Tools Needed:
 1/2 in

Ref. 215 158 / 803 605 / S-0756-C

5-7. Engine Prestart Checks

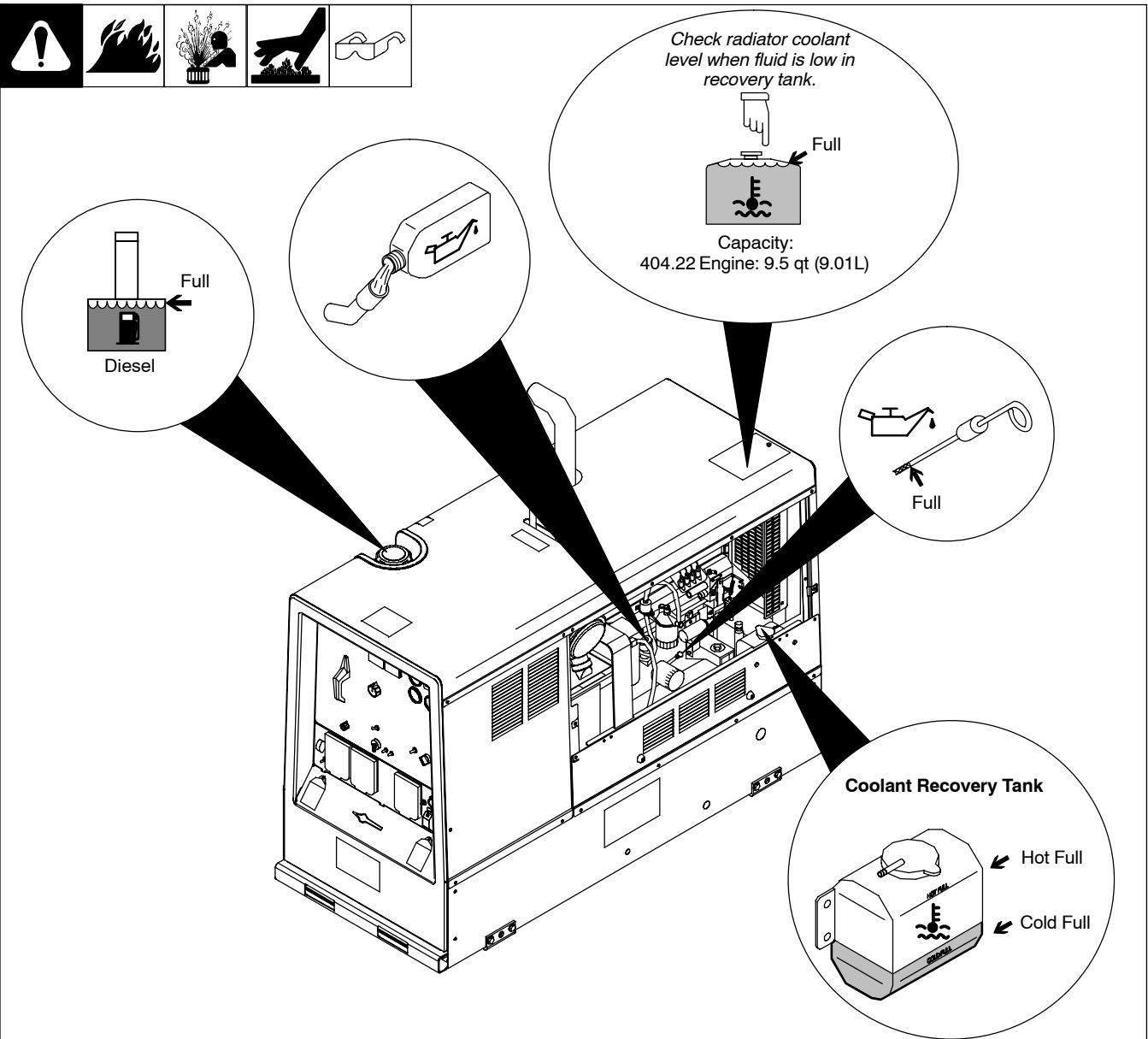

803 603

☞ Check all engine fluids daily.

Engine must be cold and on a level surface. Unit is shipped with 20W break-in oil.

Automatic shutdown system stops engine if oil pressure is too low or coolant temperature is too high.

☞ This unit has a low oil pressure shutdown switch. However, some conditions may cause engine damage before the engine shuts down. Check oil level often and do not use the oil pressure shutdown system to monitor oil level.

Follow run-in procedure in engine manual. If unburned fuel and oil collect in exhaust pipe during run-in, see Section 11.

Fuel

NOTICE – Do not use gasoline. Gasoline will damage engine.

The unit is shipped with enough fuel to prevent air from entering fuel system. Add fresh diesel fuel before starting (see engine maintenance label for fuel specifications). Leave filler neck empty to allow room for expansion.

Do not run out of fuel or air will enter fuel system and cause starting problems. See engine manual to bleed air from fuel system.

Oil

After fueling, check oil with unit on level surface. If oil is not up to full mark on dipstick, add oil (see maintenance label).

Coolant

Check coolant level in radiator before starting unit the first time. If necessary, add coolant to radiator until coolant level is at bottom of filler neck.

Check coolant level in recovery tank daily. If necessary, add coolant to recovery tank until coolant level is between Cold Full and Hot Full levels. If recovery tank coolant level was low, also check coolant level in radiator. Add coolant if level is below bottom of radiator filler neck.

Unit is shipped with an engine coolant mixture of water and ethylene glycol base anti-freeze rated to -34°F (-37°C). Add anti-

freeze to mixture if using the unit in temperatures below -34°F (-37°C).

Keep radiator and air intake clean and free of dirt.

NOTICE – Incorrect engine temperature can damage engine. Do not run engine without a properly working thermostat and radiator cap.

☞ To improve cold weather starting:

Use Starting Aid switch (see Section 6-1 or 7-1).

Keep battery in good condition. Store battery in warm area.

Use fuel formulated for cold weather (diesel fuel can gel in cold weather). Contact local fuel supplier for fuel information.

Use correct grade oil for cold weather (see Section 9-1).

5-8. Connecting To Weld Output Terminals

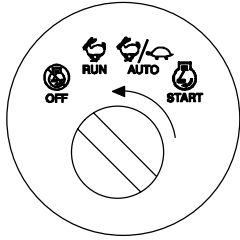
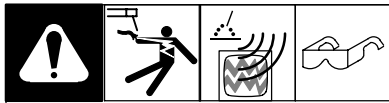

⚠ Stop engine.

- 1 Positive (+) Weld Output Terminal
- 2 Negative (-) Weld Output Terminal

⚠ Failure to properly connect weld cables may cause excessive heat and start a fire, or damage your machine.

- 3 Weld Output Terminal
- 4 Supplied Weld Output Terminal Nut
- 5 Weld Cable Terminal
- 6 Copper Bar

Remove supplied nut from weld output terminal. Slide weld cable terminal onto weld output terminal and secure with nut so that weld cable terminal is tight against copper bar. **Do not place anything between weld cable terminal and copper bar. Make sure that the surfaces of the weld cable terminal and copper bar are clean.**

Tools Needed:

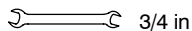

Stick and TIG Welding

For Stick and TIG welding Direct Current Electrode Positive (DCEP), connect electrode holder cable to Positive (+) terminal on left and work cable to Negative (-) terminal on right.

For Direct Current Electrode Negative (DCEN), reverse cable connections.

If equipped with optional Polarity switch or optional Polarity/AC switch, connect electrode holder cable to Electrode (+) terminal on left and work cable to Work (-) terminal on right.

MIG and FCAW Welding

For MIG and FCAW welding Direct Current Electrode Positive (DCEP) on CC/CV models, connect wire feeder cable to Positive (+) terminal on left and work cable to Negative (-) terminal on right. Use Process/Contactor switch to select type of weld output (see Section 7-3).

For Direct Current Electrode Negative (DCEN), reverse cable connections.

If equipped with optional Polarity switch or optional Polarity/AC switch, connect wire feeder cable to Electrode (+) terminal on left and work cable to Work (-) terminal on right.

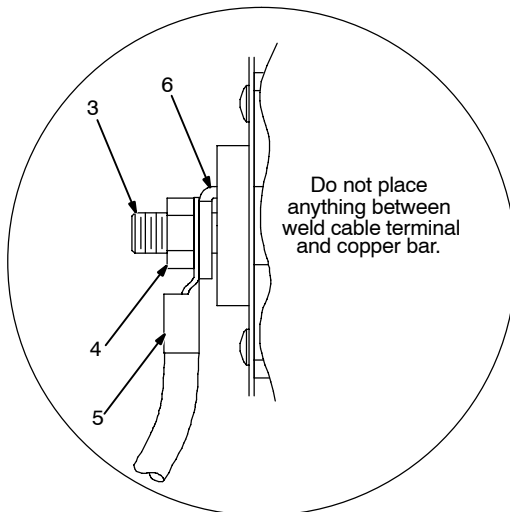
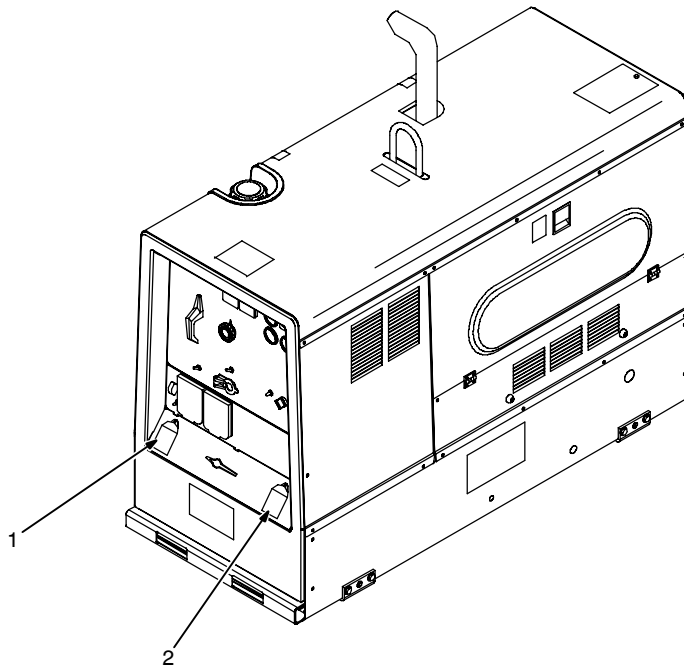

Correct Installation

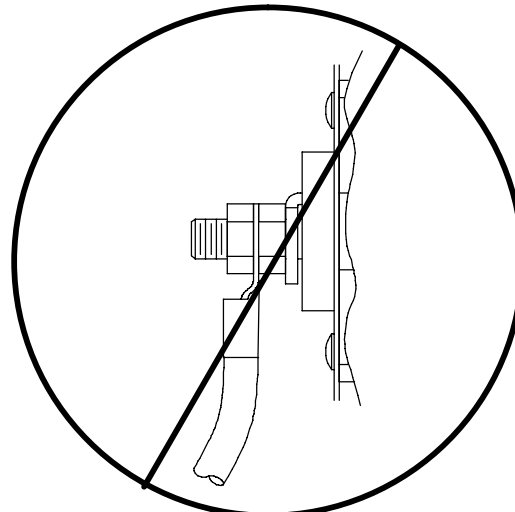

Incorrect Installation

Do not place anything between weld cable terminal and copper bar.

803 602 / 803 778-A

5-9. Selecting Weld Cable Sizes*

 <p>Weld Output Terminals</p> <p>⚠ Stop engine before connecting to weld output terminals.</p> <p>⚠ Do not use worn, damaged, undersized, or poorly spliced cables.</p>	Weld Cable Size** and Total Cable (Copper) Length in Weld Circuit Not Exceeding***										
	100 ft (30 m) or Less		150 ft (45 m)	200 ft (60 m)	250 ft (70 m)	300 ft (90 m)	350 ft (105 m)	400 ft (120 m)			
	Welding Amperes	10 – 60% Duty Cycle	60 – 100% Duty Cycle	10 – 100% Duty Cycle							
100	4 (20)	4 (20)	4 (20)	3 (30)	2 (35)	1 (50)	1/0 (60)	1/0 (60)			
150	3 (30)	3 (30)	2 (35)	1 (50)	1/0 (60)	2/0 (70)	3/0 (95)	3/0 (95)			
200	3 (30)	2 (35)	1 (50)	1/0 (60)	2/0 (70)	3/0 (95)	4/0 (120)	4/0 (120)			
250	2 (35)	1 (50)	1/0 (60)	2/0 (70)	3/0 (95)	4/0 (120)	2 ea. 2/0 (2x70)	2 ea. 2/0 (2x70)			
300	1 (50)	1/0 (60)	2/0 (70)	3/0 (95)	4/0 (120)	2 ea. 2/0 (2x70)	2 ea. 3/0 (2x95)	2 ea. 3/0 (2x95)			
350	1/0 (60)	2/0 (70)	3/0 (95)	4/0 (120)	2 ea. 2/0 (2x70)	2 ea. 3/0 (2x95)	2 ea. 3/0 (2x95)	2 ea. 4/0 (2x120)			
400	1/0 (60)	2/0 (70)	3/0 (95)	4/0 (120)	2 ea. 2/0 (2x70)	2 ea. 3/0 (2x95)	2 ea. 4/0 (2x120)	2 ea. 4/0 (2x120)			
500	2/0 (70)	3/0 (95)	4/0 (120)	2 ea. 2/0 (2x70)	2 ea. 3/0 (2x95)	2 ea. 4/0 (2x120)	3 ea. 3/0 (3x95)	3 ea. 3/0 (3x95)			

*Chart is a general guideline and may not suit all applications. If cables overheat, use next size larger cable.

**Weld cable size (AWG) is based on either a 4 volts or less drop or a current density of at least 300 circular mils per ampere.
() = mm² for metric use

***For distances longer than those shown in this guide, call a factory applications representative at 920-735-4505.

S-0007-F

5-10. Connecting To Remote Amperage Adjust Receptacle RC13 On CC Models

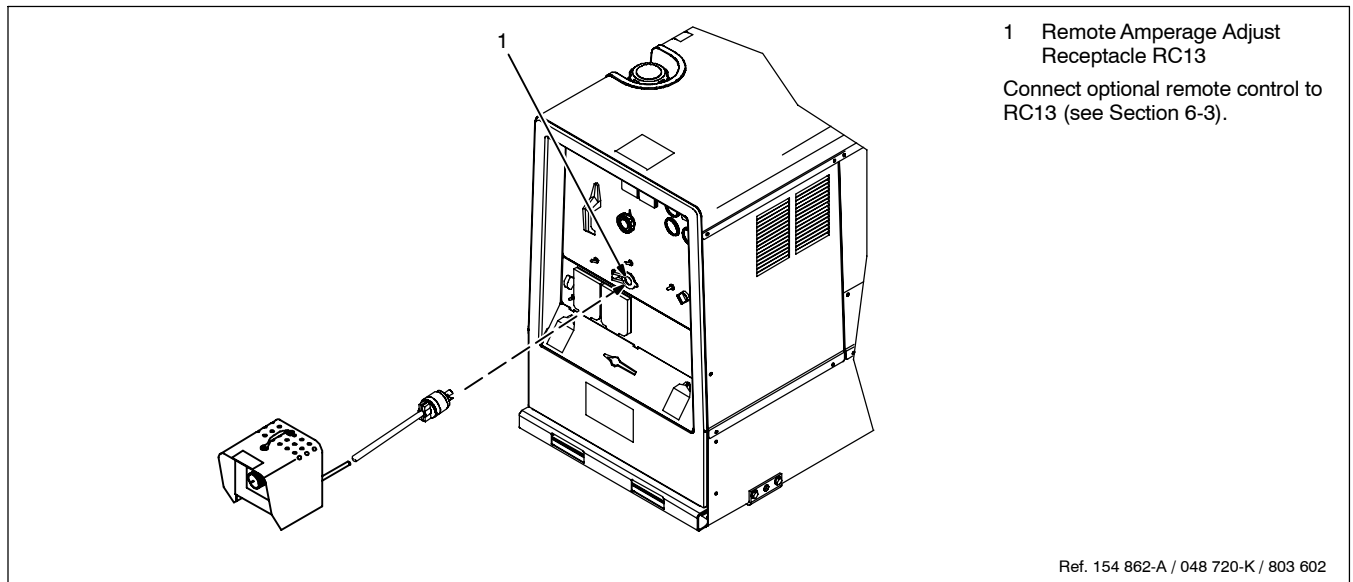

5-11. Connecting To Remote 14 Receptacle RC14 On CC/CV Models

 REMOTE 14	Socket*	Socket Information
24 VOLTS AC OUTPUT (CONTACTOR)	A	24 volts ac. Protected by supplementary protector CB5.
	B	Contact closure to A completes 24 volt ac contactor control circuit.
REMOTE OUTPUT CONTROL	C	Output to remote control: +10 volts dc in MIG or Stick mode; 0 to +10 volts dc in TIG mode.
	D	Remote control circuit common.
	E	DC input command signal: 0 to +10 volts from min. to max. of remote control with Voltage/ Amperage Adjust control at max.
115 VOLTS AC OUTPUT (CONTACTOR)	I	115 volts, 10 amperes, 60 Hz ac. Protected by supplementary protector CB6.
	J	Contact closure to I completes 115 volt ac contactor control circuit.
GND	K	Chassis common.
NEUTRAL	G	Circuit common for 24 and 115 volt ac circuit.

Ref. 803 602

*The remaining sockets are not used.

Notes



HOBART INSTITUTE
OF WELDING TECHNOLOGY

400 Trade Square East, Troy, Ohio 45373
1-800-332-9448 www.welding.org

**Start Your Professional
Welding Career Now!**

**Over 80,000 trained
since 1930!**

SECTION 6 – OPERATING WELDING GENERATOR – CC MODELS

6-1. Front Panel Controls For CC Models (See Section 6-2)

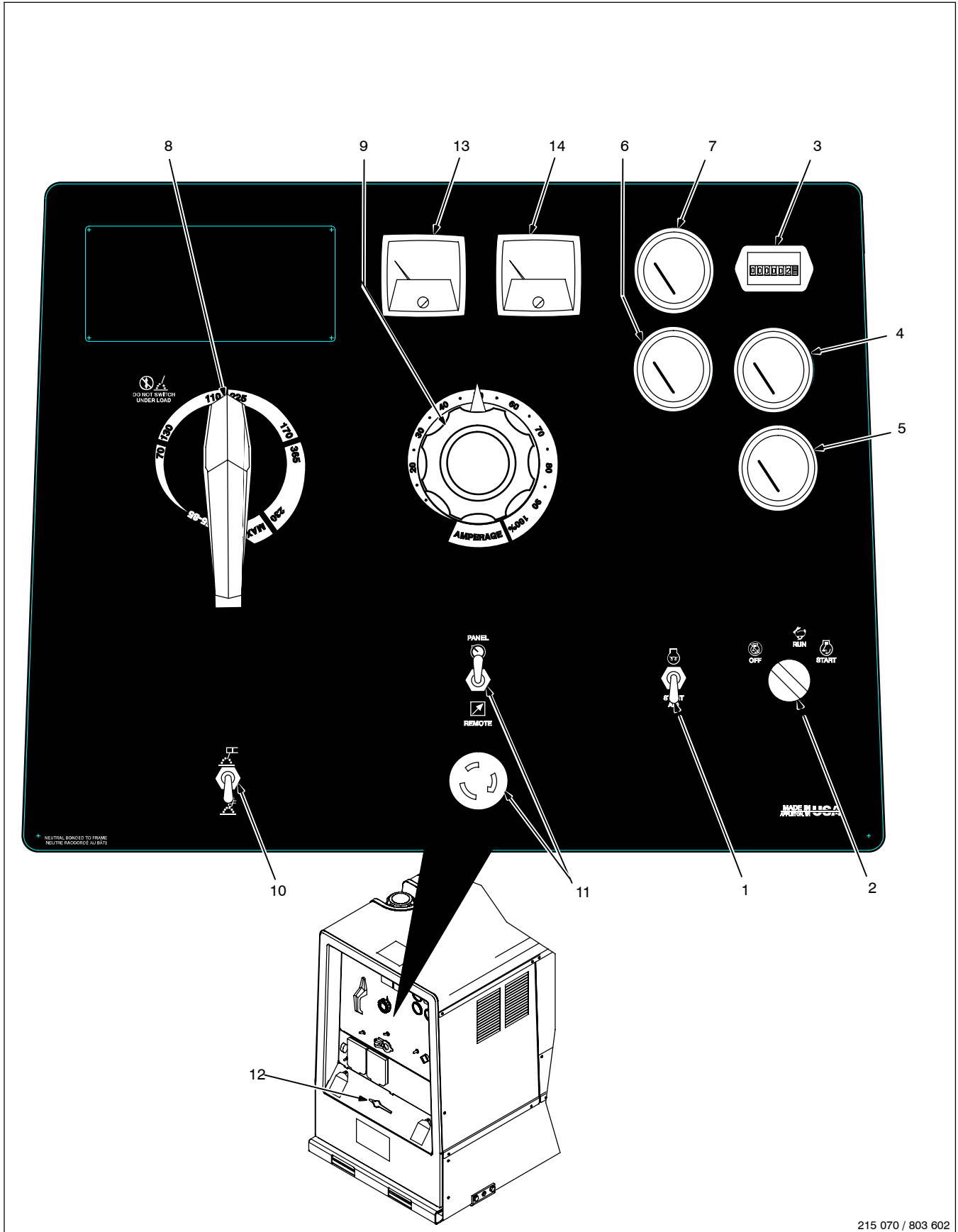

215 070 / 803 602

6-2. Description Of Front Panel Controls For CC Models (See Section 6-1)

Engine Starting Controls											
1 Starting Aid Switch											
Use switch to energize starting aid for cold weather starting (see starting instructions following).											
2 Engine Control Switch											
Use switch to start and stop engine.											
To Start:											
NOTICE – Do not use ether. Using ether voids warranty.											
If engine does not start, let engine come to a complete stop before attempting re-start.											
Above 32° F (0° C): turn Engine Control switch to Start. Release Engine Control switch when engine starts.											
Below 32° F (0° C): push Starting Aid switch up for 60 seconds. While still holding Starting Aid switch, turn Engine Control switch to Start. Release Engine Control switch and Starting Aid switch when engine starts.											
To Stop: turn Engine Control switch to Off position.											
Engine Gauges And Meters											
3 Engine Hour Meter											
Use hour meter to monitor engine run time to help schedule maintenance.											
4 Fuel Gauge											
Use gauge to check fuel level.											
To check fuel level when engine is not running, turn Engine Control switch to Run position.											
5 Battery Voltmeter (Optional)											
Use gauge to check battery voltage and monitor the engine charging system. The meter should read about 14 volts dc when the engine is running, and about 12 volts dc when the engine is stopped.											
6 Engine Coolant Temperature Gauge (Optional)											
Normal temperature is 180 - 203° F (82 - 95° C). Engine stops if temperature exceeds 220° F (104° C).											
7 Engine Oil Pressure Gauge (Optional)											
Normal pressure is 30 – 60 psi (207 – 414 kPa). Engine stops if pressure is below 10 psi (69 kPa).											
Weld Controls											
Max OCV Control Circuit: This unit has a max OCV control circuit that resets Amperage Adjust control R1 to maximum when the arc breaks. When an arc is struck, weld output control returns to the R1 front panel or combination front panel/remote control setting. The Amperage Adjust control adjusts amperage only when welding and does not adjust open-circuit voltage.											
<i>The max OCV circuit is disabled when the Stick/TIG Selection switch is in Scratch Start TIG position (see item 10).</i>											
8 Ampere Range Switch											
NOTICE – Do not switch under load.											
Use switch to select weld amperage range. For most welding applications, use lowest amperage range possible to help prevent arc outages.											
9 Amperage Adjust Control											
Control adjusts amperage within range selected by Ampere Range switch. Weld output would be about 168 A DC with controls set as shown (50% of 110 to 225 A).											
The numbers around the control are for reference only and do not represent an actual percentage value.											
10 Stick/TIG Selection Switch											
Use switch to disable the max OCV circuit and the arc drive (dig) circuit for scratch start TIG welding (see max OCV note under Weld Controls).											
When switch is in the Stick position, the max OCV circuit resets Amperage Adjust Control R1 to maximum when the arc breaks.											
Also in the Stick position, the arc drive (dig) circuit provides additional amperage during low voltage (short arc length conditions) to prevent “sticking” electrodes.											
When switch is in Scratch Start TIG position, the max OCV and arc drive (dig) circuits are disabled and OCV changes when the control is adjusted.											
11 Amperage Adjust Switch And Remote Amperage Adjust Receptacle											
Connect optional remote control to RC13 (See Section 5-10). Use switch to select front panel or remote amperage control. For remote control, place switch in Remote position and connect remote control to Remote Amperage Adjust receptacle RC13 (see Sections 5-10 and 6-3).											
12 Polarity Switch (Optional)											
NOTICE – Do not switch under load.											
Use switch to change weld output. Select either DC Electrode Positive (DCEP) or DC Electrode Negative (DCEN).											
Weld Meters											
13 AC/DC Voltmeter (Optional)											
Voltmeter displays voltage at the weld output terminals, but not necessarily the welding arc due to resistance of cable and connections.											
14 AC/DC Ammeter (Optional)											
Ammeter displays amperage output of the unit.											

6-3. Remote Amperage Control On CC Models (Optional)

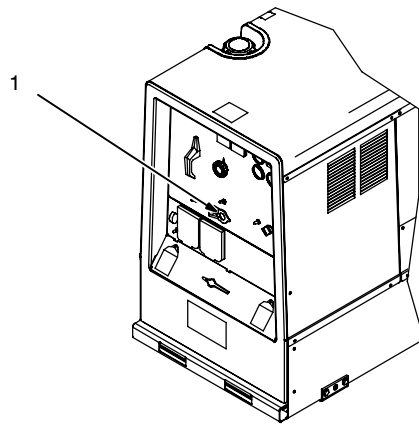

1 Remote Amperage Adjust Receptacle RC13
Connect optional remote control to RC13 (see Section 5-10).

Example: Combination Remote Amperage Control (Stick)

In Example:
Range = 110 to 225 A DC
Percentage Of Range = 50%
Max = About 168 A DC (50% of 110 to 225)

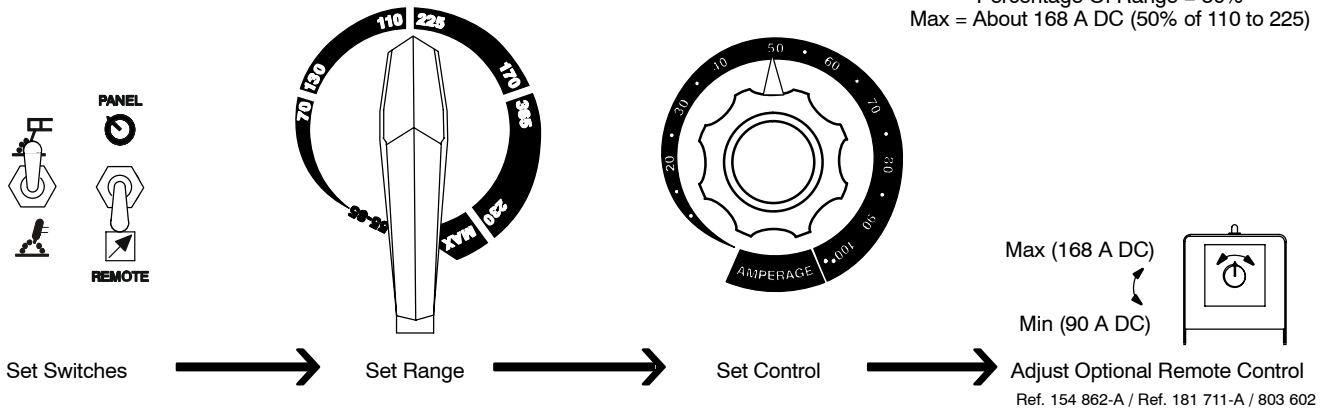

6-4. Weld Control/Arc Condition Information Label

☞ Set weld controls as shown to achieve softer or stiffer arc conditions for different applications.

SOFTER ARC
A softer arc condition can be achieved by selecting the **lowest usable range** for the electrode with a **higher fine amperage** setting preferably above 50%. This improves 6010 for uphill pipe welding by reducing Arc outages/Popouts and reduces spatter with 7018.

STIFFER ARC
A stiffer arc condition can be achieved by selecting the **highest usable range** for the electrode with a **lower fine amperage** setting preferably below 50%. This improves 6010 for downhill stick welding and 7018 for out of position welding by increasing dig.

212 944-B

212 944-B

SECTION 7 – OPERATING WELDING GENERATOR – CC/CV MODELS

7-1. Front Panel Controls For CC/CV Models (See Section 7-2)

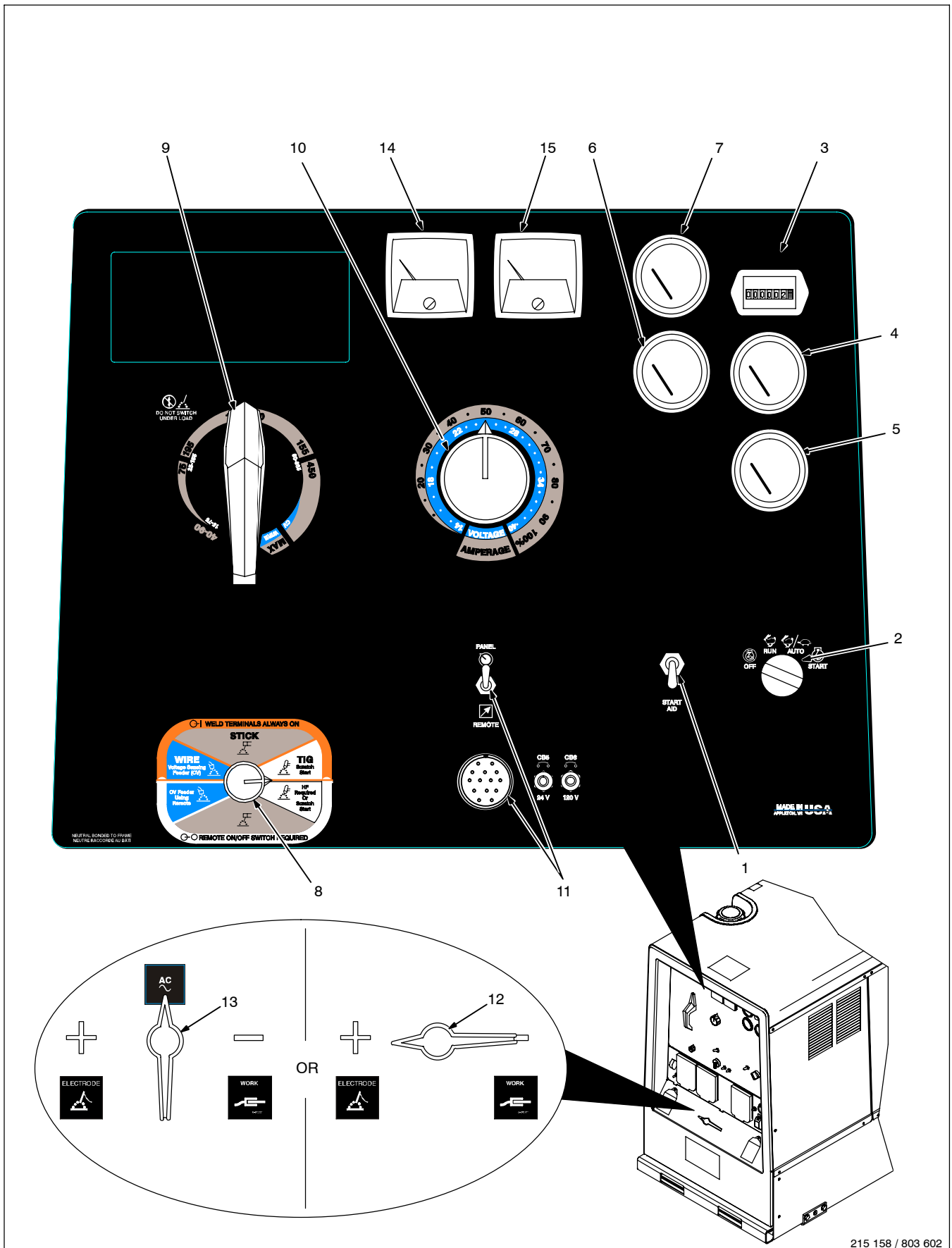

215 158 / 803 602

7-2. Description Of Front Panel Controls For CC/CV Models (See Section 7-1)

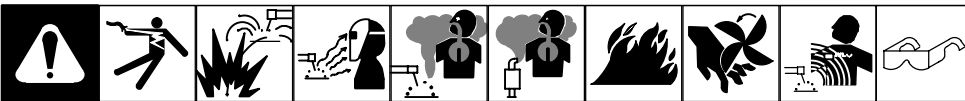

Engine Starting Controls

1 Starting Aid Switch

Use switch to energize starting aid for cold weather starting (see starting instructions following).

2 Engine Control Switch

Use switch to start engine, select engine speed (if unit has auto idle option), and stop engine.

In Run position, engine runs at weld/power speed. In Auto position (optional), engine runs at idle speed at no load and weld speed with load applied.

To Start:

NOTICE – Do not use ether. Using ether voids warranty.

If engine does not start, let engine come to a complete stop before attempting re-start.

Above 32° F (0° C): turn Engine Control switch to Start. Release Engine Control switch when engine starts.

Below 32° F (0° C): push Starting Aid switch up for 60 seconds. While still holding Starting Aid switch, turn Engine Control switch to Start. Release Engine Control switch and Starting Aid switch when engine starts.

To Stop: turn Engine Control switch to Off position.

Engine Gauges And Meters

3 Engine Hour Meter

Use hour meter to monitor engine run time to help schedule maintenance.

4 Fuel Gauge

Use gauge to check fuel level.

To check fuel level when engine is not running, turn Engine Control switch to Run position

5 Battery Voltmeter (Optional)

Use gauge to check battery voltage and moni-

tor the engine charging system. The meter should read about 14 volts dc when the engine is running, and about 12 volts dc when the engine is stopped.

6 Engine Coolant Temperature Gauge (Optional)

Normal temperature is 180 - 203° F (82 - 95° C). Engine stops if temperature exceeds 220° F (104° C).

7 Engine Oil Pressure Gauge (Optional)

Normal pressure is 30 - 60 psi (207 - 414 kPa). Engine stops if pressure is below 10 psi (69 kPa).

Weld Controls

8 Process/Contactor Switch

See Section 7-3 for Process/Contactor switch information.

9 Ampere Range Switch

NOTICE – Do not switch under load.

Use switch to select weld amperage range.

Use the lowest four ranges for Stick and TIG welding. Read the upper set of numbers at each range for Stick welding and the lower set at each range for TIG welding.

Use the highest range for MIG welding and for cutting and gouging (CAC-A).

For most welding applications, use lowest amperage range possible to help prevent arc outages.

10 Voltage/Amperage Adjust Control

With Process/Contactor switch in any Stick or TIG setting, use control to adjust amperage within range selected by Ampere Range switch. With Process/Contactor switch in any MIG position, use control to adjust voltage. With Voltage/Amperage Adjust Switch in Remote position, control limits the remote amperage in TIG mode, but has no effect in Stick and MIG modes.

Weld output would be about 218 A DC with controls set as shown (50% of 115 to 320 A).

The numbers around the control are for reference only and do not represent an actual percentage value.

11 Voltage/Amperage Adjust Switch And Remote 14 Receptacle

Use switch to select front panel or remote voltage/amperage control. For remote control, place switch in Remote position and connect remote control to Remote 14 receptacle RC14 (see Sections 5-11 and 7-4).

12 Polarity Switch (Optional)

NOTICE – Do not switch under load.

Use Polarity switch to change weld output. Select either DC Electrode Positive (DCEP) or DC Electrode Negative (DCEN).

13 Polarity/AC Switch (Optional)

⚠ Electric shock can kill.

⚠ Do not use AC output in damp areas, if movement is confined, or if there is a danger of falling.

⚠ Use AC output ONLY if required for the welding process. If AC output is required, use remote output control if present on unit.

NOTICE – Do not switch under load.

Use Polarity/AC switch to select AC or DC weld output and DC weld output polarity. For Direct Current Electrode Negative (DCEN), turn switch to - (Negative) position. For Direct Current Electrode Positive (DCEP), turn switch to + (Positive) position. For weld processes that require alternating current (AC), use AC position.

Weld Meters

14 AC/DC Voltmeter (Optional)

Voltmeter displays voltage at the weld output terminals, but not necessarily the welding arc due to resistance of cable and connections.

15 AC/DC Ammeter (Optional)

Ammeter displays amperage output of the unit.

7-3. Process/Contactor Switch On CC/CV Models

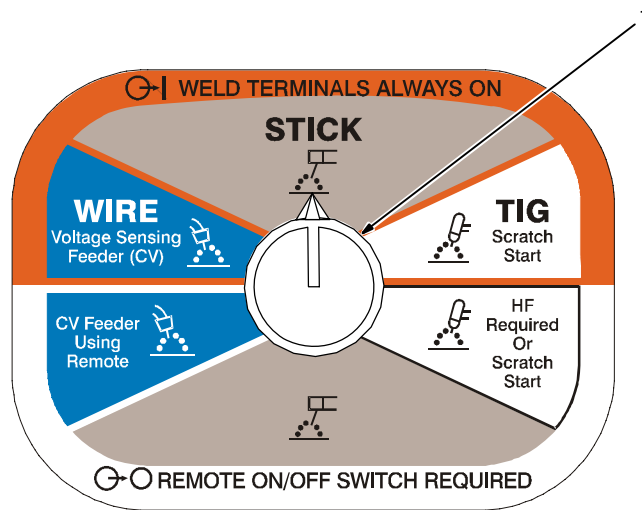

1 Process/Contactor Switch

⚠ Weld output terminals are energized when Process/Contactor switch is in an Weld Terminals Always On position and the engine is running.

⚠ DC voltage is still present at the weld terminals when Process/Contactor switch is in the Remote On/Off Switch Required – Stick position and the engine is running.

Use switch to select weld process and weld output on/off control (see table below and Section 7-4).

Place switch in Remote On/Off Switch Required positions to turn weld output to be on and off with a device connected to the remote 14 receptacle.

Place switch in Weld Terminals Always On positions for weld output to be on whenever the engine is running.

Use Stick position for air carbon arc (CAC-A) cutting and gouging.

When switch is in a Stick position, the arc drive (dig) circuit provides additional amperage during low voltage (short arc length conditions) to prevent “sticking” electrodes.

The arc drive (dig) circuit is disabled when switch is in MIG or TIG positions.

☞ Place switch in Weld Terminals Always On - Stick position when using optional three-phase generator (see Section 8-2).

☞ The engine auto idle option does not work in the Remote On/Off Switch Required-TIG mode.

Process/Contactor Switch Settings

Switch Setting	Process	Output On/Off Control	Engine Auto Idle (Optional)
Remote On/Off Switch Required – TIG, HF Required Or Scratch Start TIG	GTAW With HF Unit, Pulsing Device, Or Remote Control	At Remote 14 Receptacle	Not Active
Remote On/Off Switch Required – Stick	Stick (SMAW) With Remote On/Off	At Remote 14 Receptacle	Active
Remote On/Off Switch Required – CV Feeder Using Remote	MIG (GMAW)	At Remote 14 Receptacle	Active
Weld Terminals Always On – Wire	MIG (GMAW)	Electrode Hot	Active
Weld Terminals Always On – Stick	Stick (SMAW), Air Carbon Arc (CAC-A) Cutting And Gouging	Electrode Hot	Active
Weld Terminals Always On – TIG, Scratch Start	TIG Scratch Start (GTAW)	Electrode Hot	Active

7-4. Remote Voltage/Amperage Control On CC/CV Models (Optional)



1 Remote 14 Receptacle RC14
Connect optional remote control to RC14 (see Section 5-11).

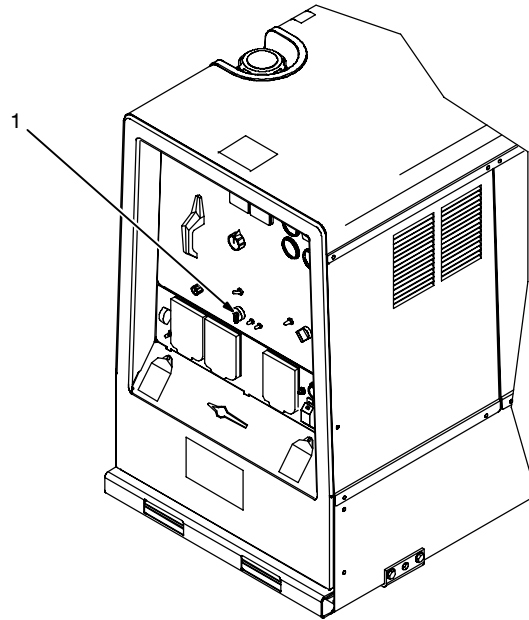

Example: Combination Remote Amperage Control (Stick)

In Example:
Process = Stick (Using Remote On/Off)
Range = 115 to 320 A DC
Min = 115 A DC
Max = 320 A DC

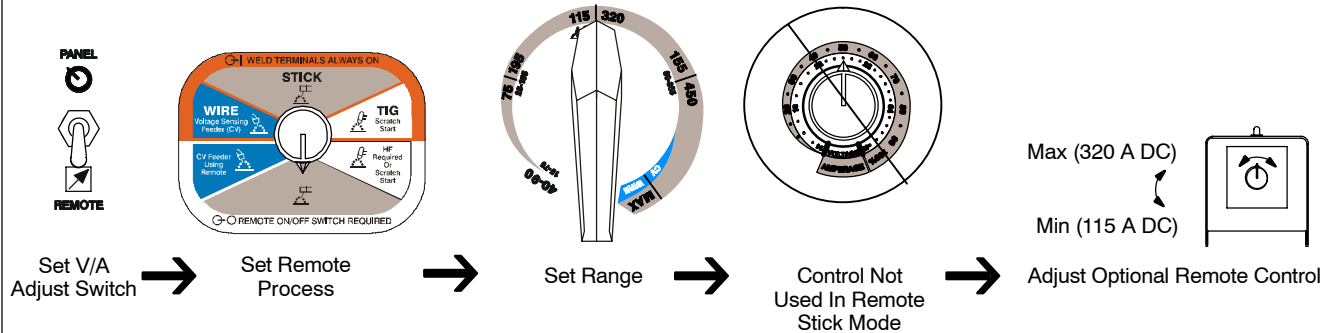

Example: Combination Remote Amperage Control (TIG)

In Example:
Process = TIG (Using Remote On/Off)
Range = 35 to 250 A DC
Percentage Of Range = 50%
Min = 35 A DC
Max = About 143 A DC (50% of 35 to 250)

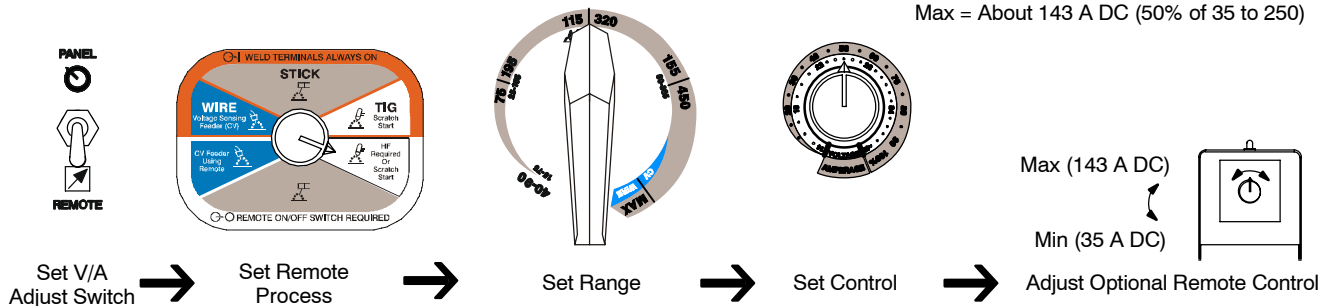

SECTION 8 – OPERATING AUXILIARY EQUIPMENT

8-1. 120 Volt And 240 Volt Receptacles

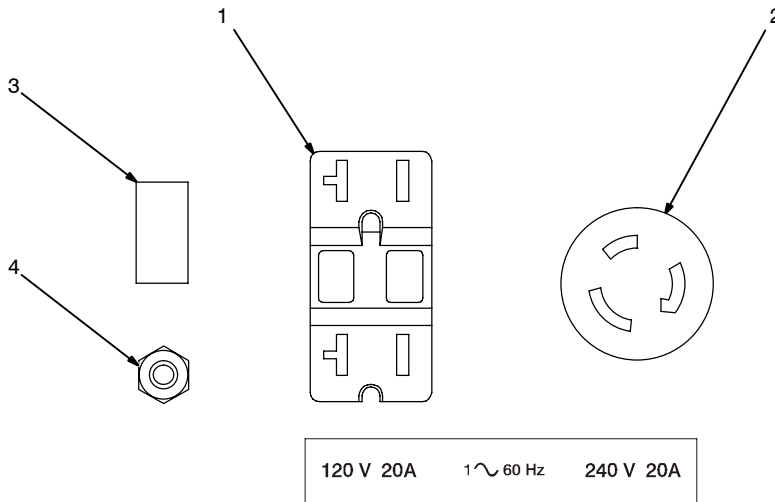

- 1 120 V 20 A AC GFCI Receptacle GFCI1
- 2 240 V 30 A AC Twistlock Receptacle RC1

Receptacles supply 60 Hz single-phase power at weld/power speed.

If a ground fault is detected, GFCI Reset button pops out and receptacle does not work. Check for faulty tools plugged in receptacle. Press button to reset GFCI1.

At least once a month, run engine at weld/power speed and press test button to verify GFCI is working properly.

- 3 Supplementary Protector CB1
- 4 Supplementary Protector CB2

CB1 protects RC1 and the generator winding from overload. If CB1 opens, RC1 and GFCI1 do not work. Place switch in On position to reset.

CB2 protects GFCI1 from overload. If CB2 opens, GFCI1 does not work. Press button to reset.

If a supplementary protector continues to open, contact Factory Authorized Service Agent.

Generator power is not affected by weld output.

Maximum output is 2.4 kVA/kW from GFCI1 and 4 kVA/kW from RC1. Maximum output from all receptacles is 4 kVA/kW.

EXAMPLE: If 13 A is drawn from RC1, only 7 A is available at GFCI1:

$$(240 \text{ V} \times 13 \text{ A}) + (120 \text{ V} \times 7 \text{ A}) = 4.0 \text{ kVA/kW}$$

8-2. Connecting To Optional Three-Phase Generator (CC/CV Models Only)

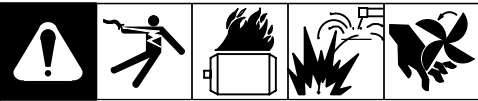

Single-Phase Power Connection

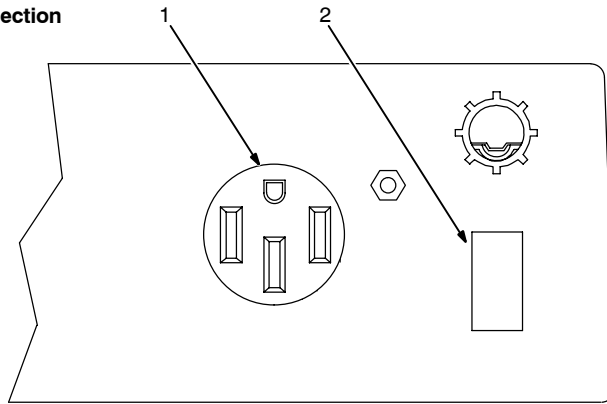

☞ Place Process/Contactor switch in Weld Terminals Always On - Stick position when using three-phase generator (see Section 7-3).

Single-Phase Generator Power

- 1 120/240 V 50 A Receptacle RC5

RC5 is connected to the optional three-phase generator and supplies 60 Hz single-phase power at weld/power speed. Maximum output from RC5 is 12 kVA/kW. Power available at RC5 is reduced when welding.

- 2 Supplementary Protector CB7

Supplementary Protector CB7 protects single-phase receptacle RC5 and the load wires from overload. If CB7 opens, all generator output stops and the receptacle does not work.

Three-Phase Generator Power

⚠ **Stop engine.**

⚠ **Power and weld outputs are live at the same time. Disconnect or insulate unused cables.**

☞ Have qualified person install according to circuit diagram and Generator Power Guidelines (see Section 12).

Three-Phase Power Connection

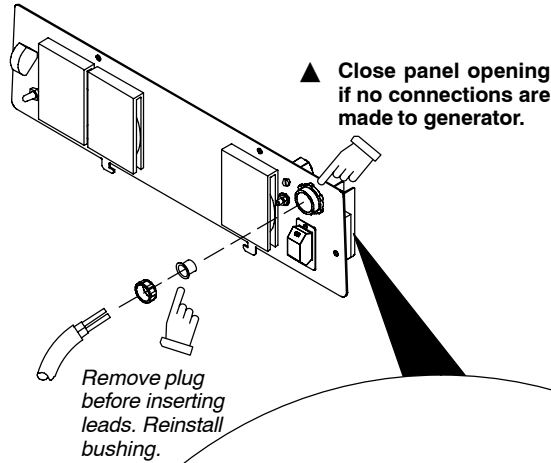

AC ~ Output	Single Phase 1 ~	Three Phase 3 ~
Volts	120/240	240
Amps	50	36
KVA/KW	12	15
Frequency	60 Hz	
Engine Speed	1850 RPM	

Lead 42 connects to GROUND stud on front of unit.
Jumper 42 is connected to 90 at factory.

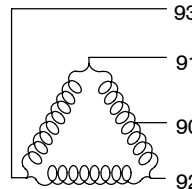

Remove generator power panel mounting screws. Tilt panel forward.

- 3 Lead 93
- 4 Lead 92
- 5 Lead 91
- 6 Lead 42 (Circuit Grounding Lead)
- 7 Lead 90 (Neutral)
- 8 Isolated Neutral Terminal
- 9 Jumper Lead 42
- 10 Grounding Terminal

Jumper 42 is connected to lead 90 at factory. Jumper 42 may be disconnected from neutral to meet applicable electrical codes.

Lead 42 connects to front panel Ground stud.

- 11 User-Supplied Leads
- 12 Supplementary Protector CB7 User Terminals

Connect user-supplied leads to terminals on CB7 and to the isolated neutral terminal and grounding terminal as necessary.

☞ Supplementary protector CB7 protects single-phase receptacle RC5 and the load wires from overload. If CB7 opens, all generator output stops and the receptacle does not work.

Reinstall generator power panel.

Tools Needed:

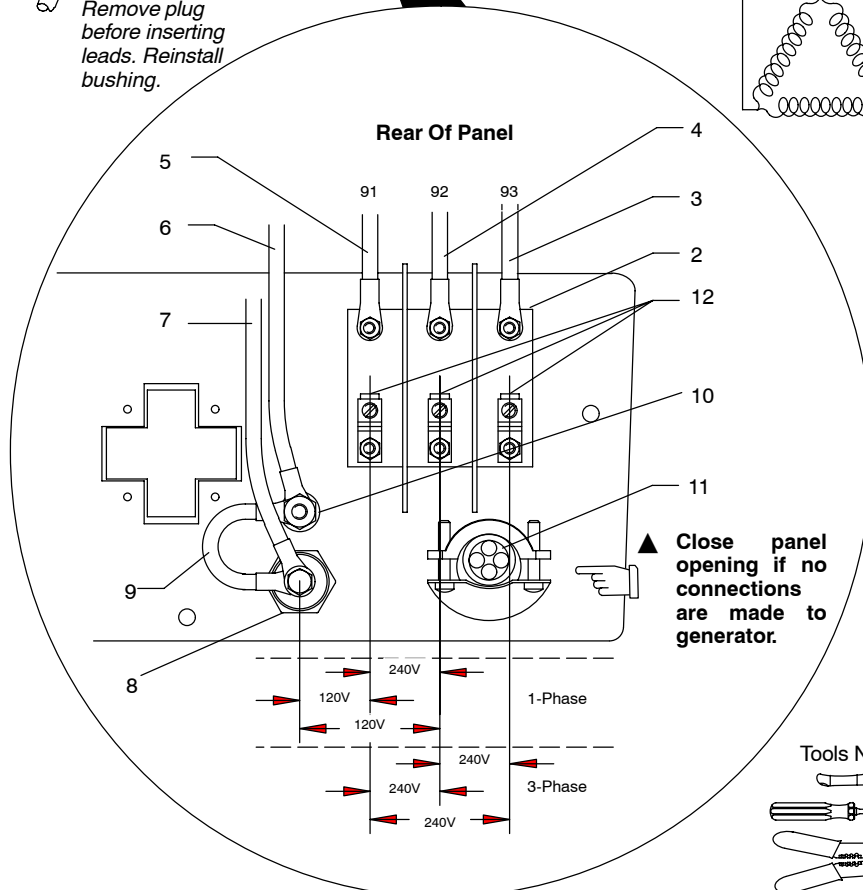
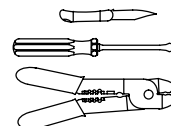

8-3. Optional Generator Power Receptacles



European Receptacle

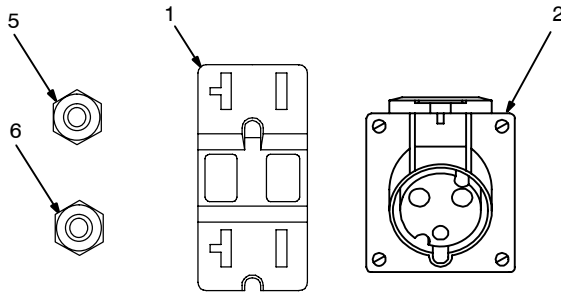

120 V 20A 1~ 60 Hz 240 V 15 A

- 1 120 V 20 A AC GFCI Receptacle GFCI1
- 2 240 V 16 A AC European Receptacle RC1
- 3 240 V 15 A AC Australian Receptacle RC1
- 4 240 V 15 A AC South African Receptacle RC1

Receptacles supply 60 Hz single-phase power at weld/power speed.

If a ground fault is detected, the GFCI Reset button pops out and the receptacle does not work. Check for faulty tools plugged in receptacle. Press button to reset GFCI1.

☞ *At least once a month, run engine at weld/power speed and press test button to verify GFCI is working properly.*

Australian Receptacle

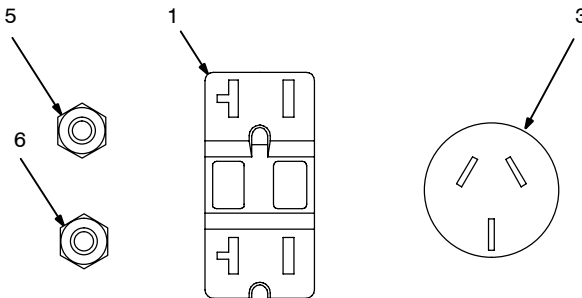

120 V 20A 1~ 60 Hz 240 V 15 A

- 5 Supplementary Protector CB2
 - 6 Supplementary Protector CB3
- CB2 protects GFCI1 from overload. If CB2 opens, GFCI1 does not work. Press button to reset.

CB3 protects RC1 from overload. If CB3 opens, RC1 does not work. Press button to reset.

☞ *If a supplementary protector continues to open, contact Factory Authorized Service Agent.*

South African Receptacle

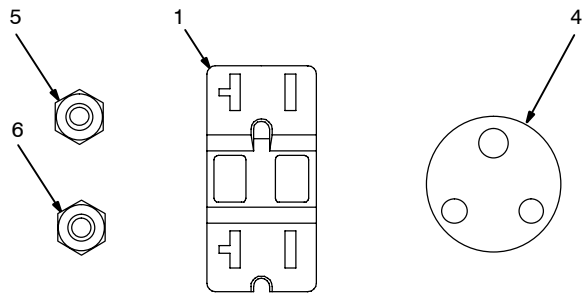

120 V 20A 1~ 60 Hz 240 V 15 A

☞ *Generator power is not affected by weld output.*

Maximum output is 2.4 kVA/kW from GFCI1 and 4 kVA/kW from RC1. Maximum output from all receptacles is 4 kVA/kW.

EXAMPLE: If 13 A is drawn from RC1, only 7 A is available at GFCI1:

$$(240 \text{ V} \times 13 \text{ A}) + (120 \text{ V} \times 7 \text{ A}) = 4.0 \text{ kVA/kW}$$

SECTION 9 – MAINTENANCE & TROUBLESHOOTING

9-1. Maintenance Label

**PERKINS 404.22 (32.6 HP)
DIESEL ENGINE**



12 V
BCI 24
650 A @ -18° C (0° F)



1250 RPM



1850 RPM

8 h std.

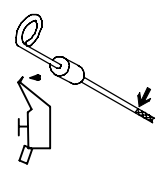
DIESEL
93.7 L (24.75 gal)
DIN 51 601
BS 2869: A1, A2
ASTM D 975-81: 1-D, 2-D
VWF 800C: DFA, DF-1, DF-2
S < = .5%

100 h std.

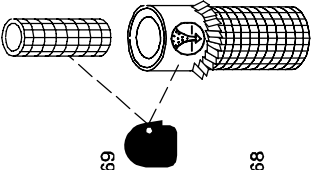

(Optional)
MILLER 192 939
Donaldson P822769
WIX 46490

MILLER 192 938
Donaldson P822768
WIX 46489

250 h std.

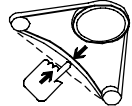
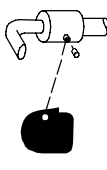
13 mm
(1/2 in)

MILLER 197 944
Perkins 080109107

500 h std.

API: CD/CE/CF-4
8.9 L (9.5 qt) min
10.6 L (11.2 qt) max

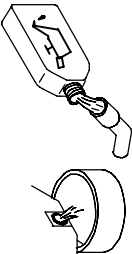
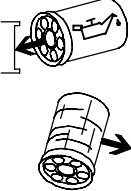
MILLER 197 899
Perkins 140516130
Fram PH2844

1000 h std.

9.01 L
(9.5 qt)

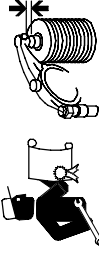
Thermostat
Perkins 145206180



20° C (72° F)
in.- 0.2 mm (0.0078 in)
ex.- 0.2 mm (0.0078 in)

1. MILLER 192 744
Donaldson P550587
Fram P1145A

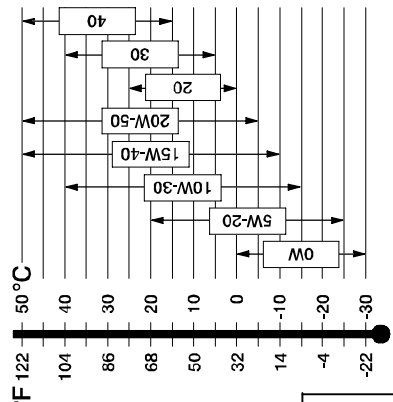
2. MILLER 197 997
Perkins 130306190



2000 h std.















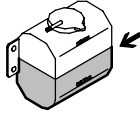

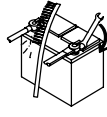

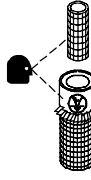

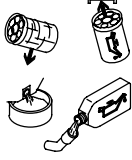
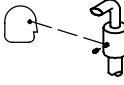
Perkins 131406360

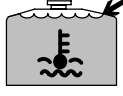
220 539-B

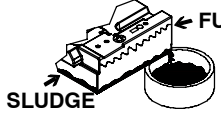
9-2. Routine Maintenance

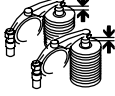
							 Recycle engine fluids.	 Stop engine before maintaining.  See Engine Manual and Maintenance Label for important start-up, service, and storage information. Service engine more often if used in severe conditions.
---	---	---	---	---	---	---	---	---

		✓ = Check ◇ = Change ● = Clean * To be done by Factory Authorized Service Agent	☆ = Replace	Reference	
Every 8 Hours	 ✓ Fuel/Water Separator	 ✓ Fuel Level	 ✓ Oil Level	 ● Oil, Fuel Spills	Section 5-7, 9-7
	 ✓ Coolant Level				
Every 50 Hours	 ● Weld Terminals				
Every 100 Hours	 ● Battery Terminals	 ✓ Air Cleaner Hoses	 ✓ Air Cleaner Element		Section 9-4
Every 250 Hours	 ☆ Unreadable Labels	 ✓ Fan Belt Tension	 ◇ Oil ◇ Oil Filter	 ✓ ● Spark Arrestor	Engine Manual, Section 9-5
Every 500 Hours	 ✓ ☆ Weld Cables				
Every 1000 Hours	 ✓ Radiator Fluid Level And Thermostat	 ● Inside Unit	 ◇ Fuel Filter	 ● Drain Sludge	Section 9-7, 9-3 and En- gine Manual
	 ✓ ● Slip Rings* ✓ ☆ Brushes*	 ✓ Valve Clearance*			
Every 2000 Hours	 ● Injectors*				

9-4. Servicing Air Cleaner

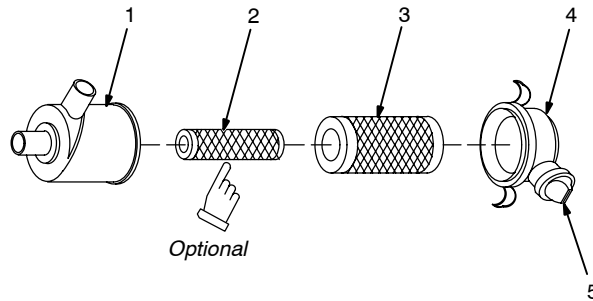
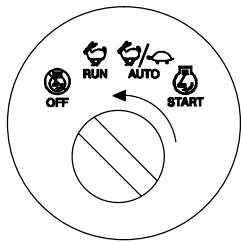

⚠ Stop engine.

NOTICE – Do not run engine without air cleaner or with dirty element. Engine damage caused by using a damaged element is not covered by the warranty.

☞ The air cleaner primary element can be cleaned but the dirt holding capacity of the filter is reduced with each cleaning. The chance of dirt reaching the clean side of the filter while cleaning and the possibility of filter damage makes cleaning a risk. Consider the risk of unwarrantable equipment damage when determining whether to clean or replace the primary element.

If you decide to clean the primary element, we strongly recommend installing an optional safety element to provide additional engine protection. **Never clean a safety element.** Replace the safety element after servicing the primary element three times.

Clean or replace primary element if dirty (see note above before cleaning). **Replace** primary element if damaged. Replace primary element yearly or after six cleanings.

- 1 Housing
- 2 Safety Element (Optional)
- 3 Primary Element
- 4 Dust Cap
- 5 Dust Ejector

To clean air filter:

Wipe off cap and housing. Remove cap and dump out dust. Remove element(s). Wipe dust from inside cap and housing with damp cloth. Reinstall safety element (if present). Reinstall cap.

NOTICE – Do not clean housing with air hose.



Clean primary element with compressed air only.

Air pressure must not exceed 100 psi (690 kPa). Use 1/8 in (3 mm) nozzle and keep nozzle at least 2 in (51 mm) from inside of element. Replace primary element if it has holes or damaged gaskets.

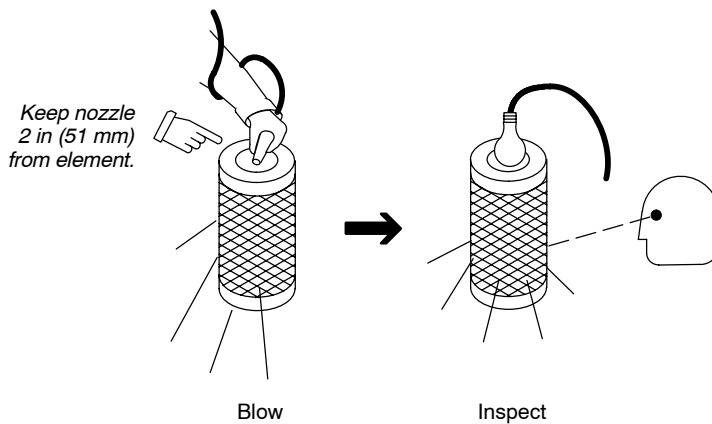
Reinstall primary element and cap (dust ejector down).

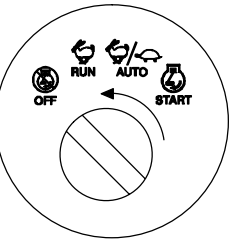

9-5. Inspecting And Cleaning Optional Spark Arrestor Muffler



⚠ Stop engine and let cool.

- 1 Spark Arrestor Muffler
- 2 Cleanout Plug

Remove plug and remove any dirt covering cleanout hole.

Start engine and run at idle speed to blow out cleanout hole. If nothing blows out of hole, briefly cover end of exhaust pipe with fireproof material.

⚠ Stop engine and let cool.

Reinstall cleanout plug.

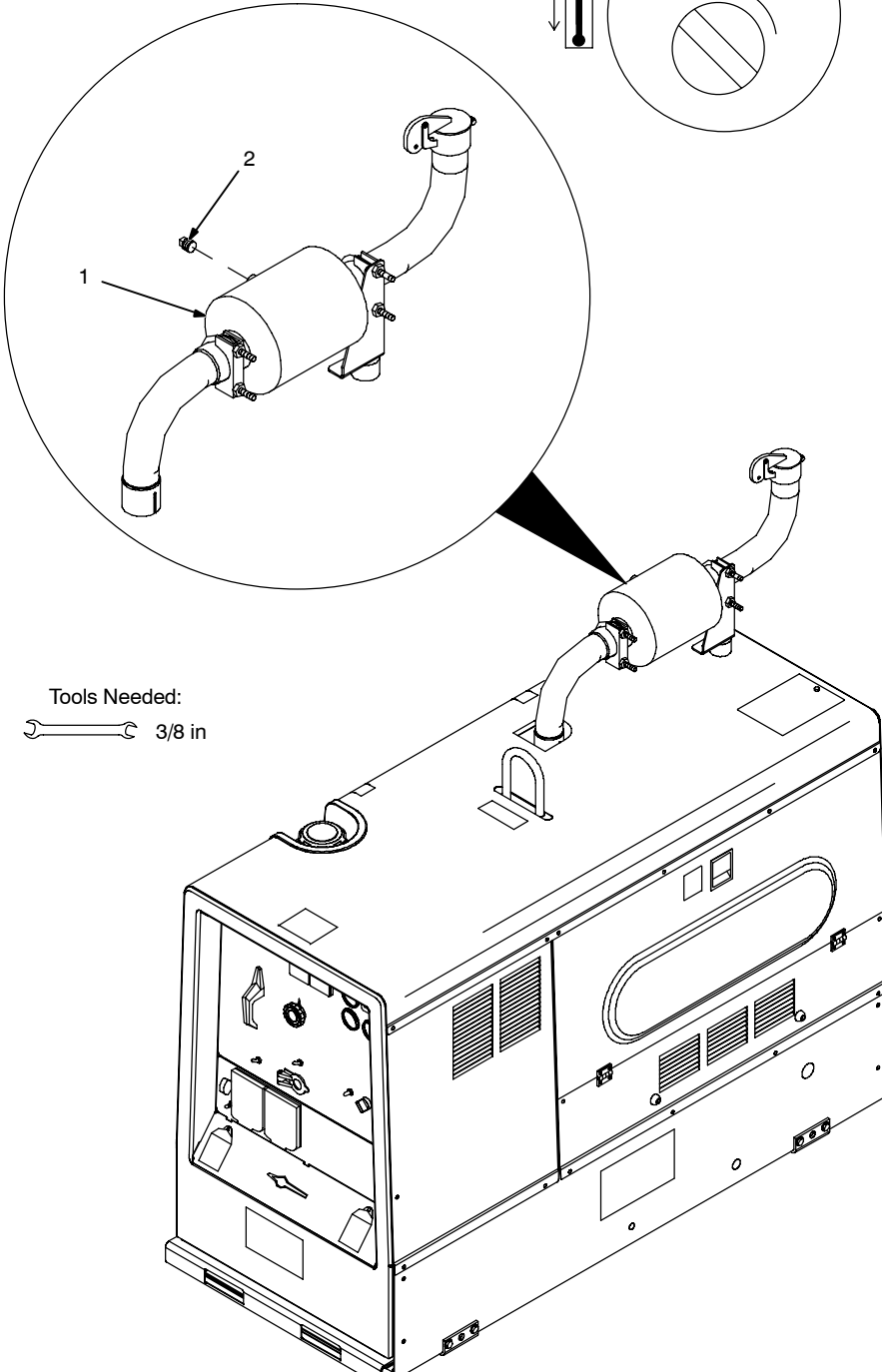

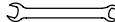
Tools Needed:
 3/8 in

803 656 / Ref. 215 158

9-6. Adjusting Engine Speed

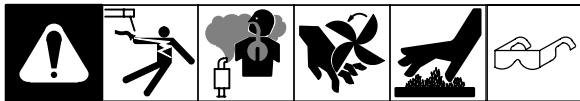

Engine Speed (No Load)	
	1850 rpm max (61.6 Hz)
	1250 rpm (41.6 Hz)

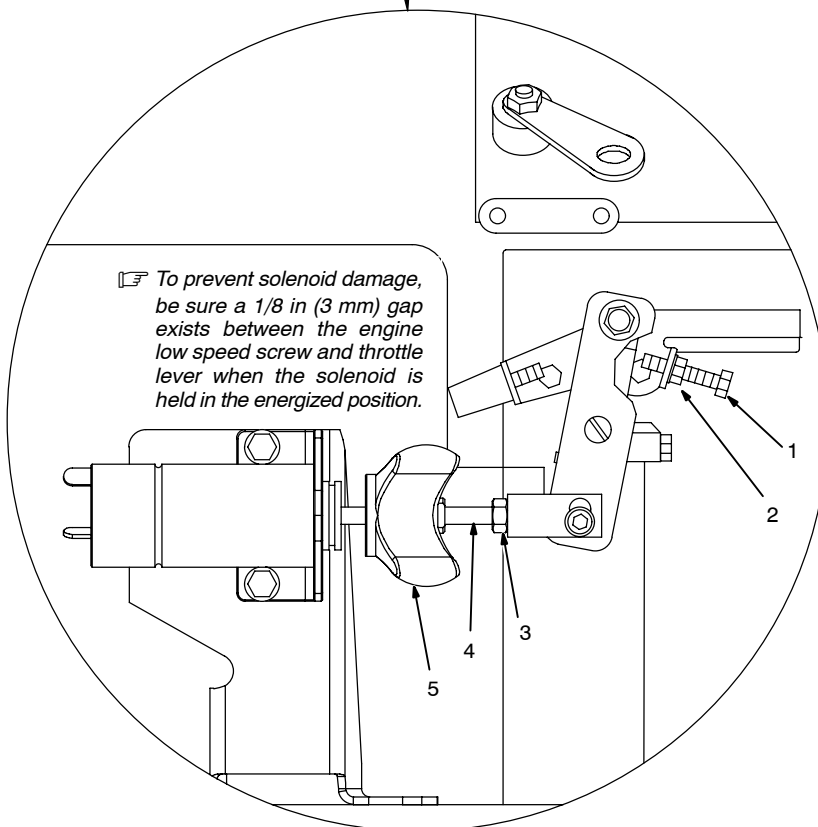
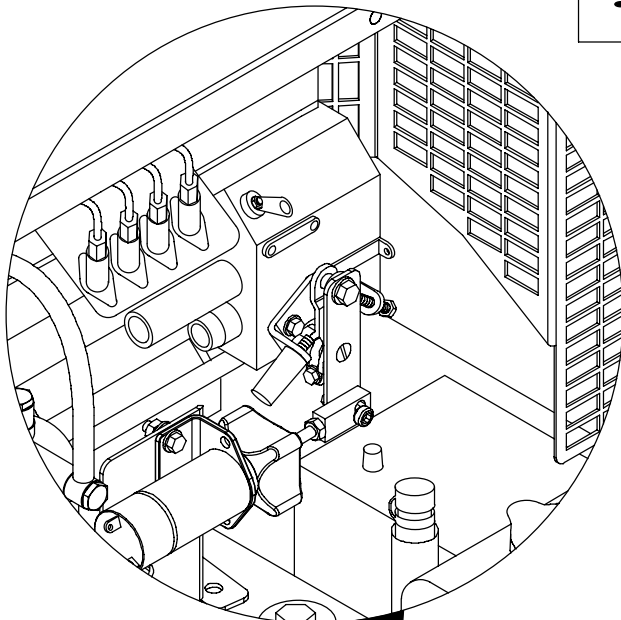

After tuning engine, check engine speed with tachometer or frequency meter. See table for proper no load speed.

Start engine and run until warm.

On CC models, place Stick/TIG switch in Stick position.

On CC/CV models, turn Process/Contactor switch to Stick – Weld Terminals Always On position.

- 1 Low Speed Adjustment Screw
- 2 Lock Nut

Standard Model Idle Speed Adjustment

Loosen lock nut. Turn screw until engine runs at idle speed. Tighten nut.

Models With Automatic Idle Option

- 3 Throttle Rod Lock Nut
- 4 Throttle Rod / Plunger
- 5 Rubber Boot

Adjustment screw is not used to adjust engine speed when automatic idle option is installed. However, it must be at least 1/8 in (3 mm) away from the throttle arm when engine is running at idle rpm.

Unhook rubber boot from the solenoid housing but leave connected to plunger.

Loosen lock nut. Place Engine Control Switch in Auto position.

Turn throttle rod and plunger until engine runs at idle speed. Tighten lock nut.

Hook rubber boot back onto solenoid housing.

Be sure solenoid plunger pulls all the way in ("bottoms") when energized.

Weld/Power Speed Adjustment

Weld/power speed adjustment must be done by the engine manufacturer's factory authorized service agent. Tampering with adjustments other than shown may affect engine warranty.

Stop engine.

9-7. Servicing Fuel And Lubrication Systems

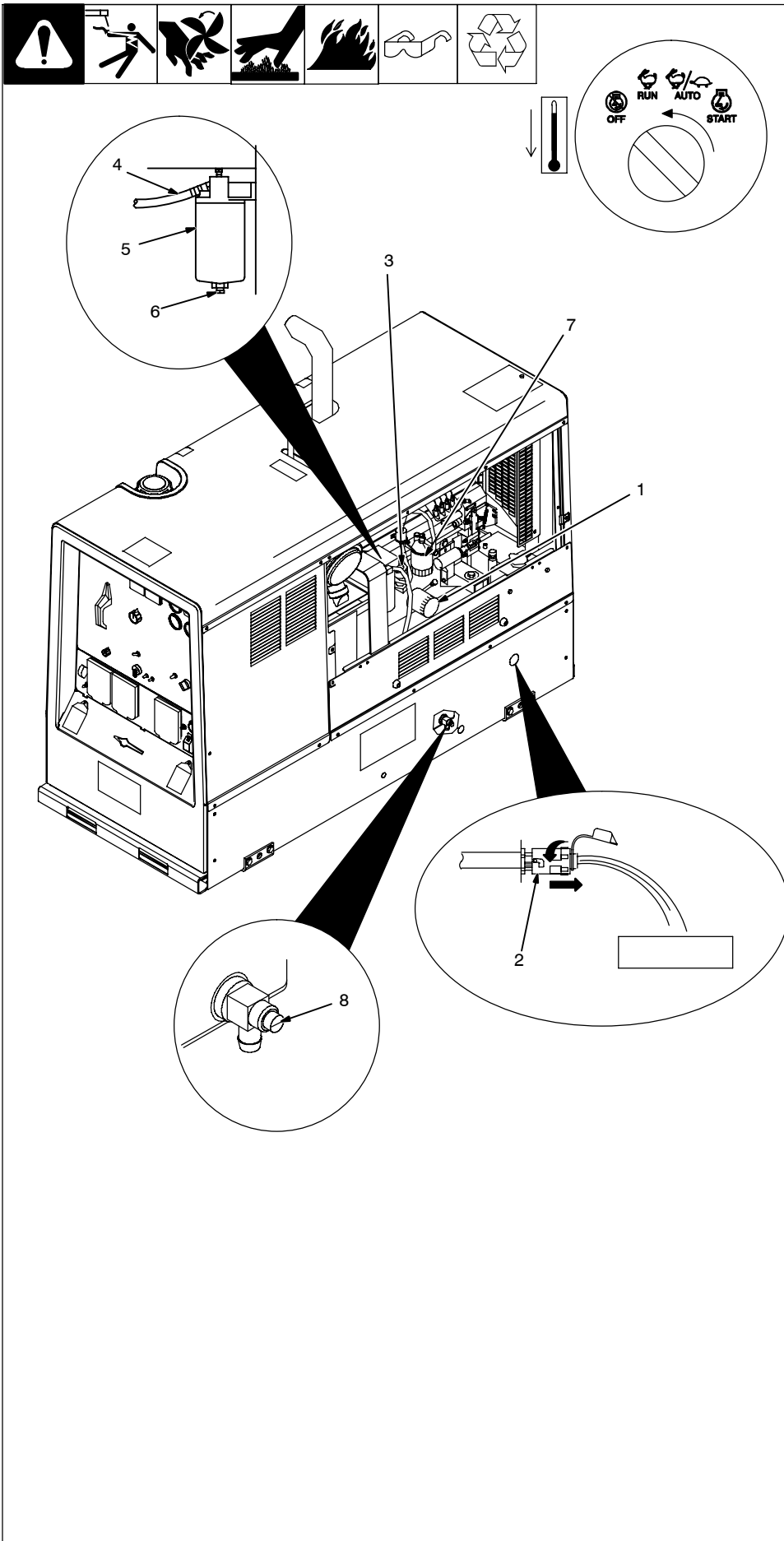

⚠ Stop engine and let cool.

⚠ After servicing, start engine and check for fuel leaks. Stop engine, tighten connections as necessary, and wipe up spilled fuel.

- 1 Oil Filter
- 2 Oil Drain Valve And Hose
- 3 Oil Fill Cap
- 4 Fuel Line
- 5 Primary Fuel Filter (Fuel/Water Separator)
- 6 Petcock
- 7 Secondary Fuel Filter
- 8 Fuel Tank Sludge Drain Valve

To change oil and filter:

Route oil drain hose and valve through hole in base. See engine manual and engine maintenance label for oil/filter change information.

To drain water from fuel system:

Open primary fuel filter petcock and drain water into metal container. Close petcock when water-free fuel flows.

To replace primary fuel filter:

Turn filter counterclockwise. Remove filter.

Fill new filter with fresh fuel. Apply thin coat of fuel to gasket on new filter. Install new filter and turn clockwise. Bleed air from fuel system according to engine manual.

Inspect fuel lines, and replace if cracked or worn.

To replace secondary fuel filter:

See engine manual.

To drain sludge from fuel tank:

⚠ Beware of fire. Do not smoke and keep sparks and flames away from drained fuel. Dispose of drained fuel in an environmentally-safe manner. Do not leave unit unattended while draining fuel tank.

⚠ Properly lift unit and secure in a level position. Use adequate blocks or stands to support unit while draining fuel tank.

Attach 1/2 ID hose to drain valve. Put metal container under drain, and use screwdriver to open sludge drain valve. Close valve when sludge has drained. Remove hose.

Close door. Tools Needed:

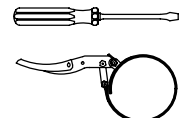

9-8. Overload Protection

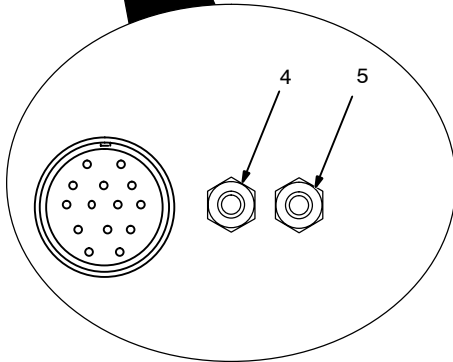
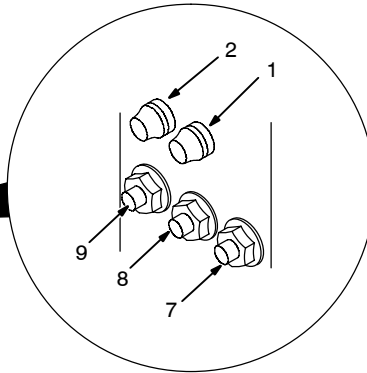
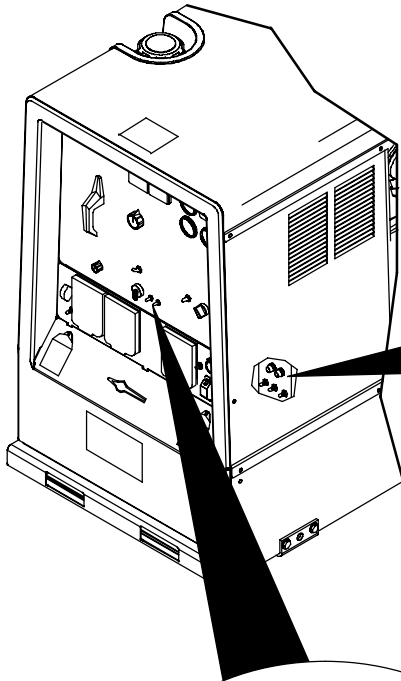
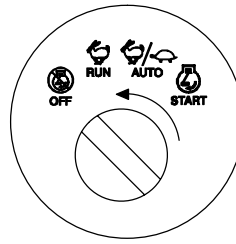

⚠ Stop engine.

☞ When a supplementary protector, circuit breaker or fuse opens, it usually indicates a more serious problem exists. Contact Factory Authorized Service Agent.

- 1 Fuse F1
- 2 Fuse F2

F1 and F2 protect the stator exciter winding from overload. If F1 opens, weld and generator power is low or stops entirely. If F2 opens, weld output is low or stops entirely. 4 kVA/kW generator power is still available.

- 3 Circuit Breaker CB4 (Not Shown)
- 4 Supplementary Protector CB5 (CC/CV Models Only)
- 5 Supplementary Protector CB6 (CC/CV Models Only)
- 6 Circuit Breaker CB10 (Not Shown)
- 7 Supplementary Protector CB11
- 8 Supplementary Protector CB12
- 9 Supplementary Protector CB13
- 10 Circuit Breaker CB14 (Not Shown)

CB4 protects the welding arc drive (dig) circuit. If CB4 opens, electrode may stick to the workpiece more frequently during low voltage (short arc length) conditions. CB4 automatically resets when the fault is corrected.

CB5 protects the 24 volt ac output to remote receptacle RC14, and 24 volt output to field current regulator board PC1 (CC/CV models only). If CB5 opens, weld output and 24 volt output to RC14 stops. On units with optional three-phase generator, generator power output at receptacle RC5 also stops if CB5 opens.

CB6 protects the 115 volt ac output to remote receptacle RC14 (CC/CV models only). If CB6 opens, 115 volt output to RC14 stops.

CB10 protects the engine battery circuit. If CB10 opens, the engine will not crank. CB10 automatically resets when the fault is corrected.

CB11 protects the weld control circuit. On CC models, if CB11 opens the max OCV circuit does not work and open circuit voltage is variable at all times (see max OCV note under Weld Controls in Section 6-2). If CB11 opens on CV models, weld output stops (generator power is still available).

CB12 protects the field flashing circuit. If CB12 opens, the generator may not excite at start-up and weld and generator power output may not be available.

CB13 protects the engine control circuit. If CB13 opens, the engine does not crank.

CB14 protects throttle solenoid TS1 on units with auto idle option. If CB14 opens, the engine does not run at idle speed. CB14 automatically resets when the fault is corrected.

Press button to reset supplementary protector.

9-9. Troubleshooting

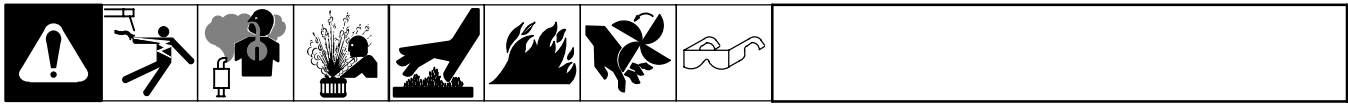

A. Welding – CC Models

Trouble	Remedy
No weld output; generator power output okay at ac receptacles.	Check position of Ampere Range switch.
	Check position of optional Polarity switch.
	Place Amperage Adjust switch in Panel position, or place switch in Remote position and connect remote control to Remote Amperage Adjust receptacle RC13 (see Sections 5-10 and 6-1).
	Check and secure connections to Remote Amperage Adjust receptacle RC13 (see Section 5-10).
	Check fuse F2, and replace if open (see Section 9-8). Have Factory Authorized Service Agent check integrated rectifier SR2 and the rotor.
	Have Factory Authorized Service Agent check brushes and slip rings, and weld excitation circuit.
No weld output or generator power output at ac receptacles.	Disconnect equipment from generator power receptacles during start-up.
	Check fuses F1 and F2, and replace if open (see Section 9-8). Have Factory Authorized Service Agent check integrated rectifier SR1, capacitor C9, integrated rectifier SR2, and the rotor.
	Reset supplementary protector CB12. Have Factory Authorized Service Agent check diode D1 (see Section 9-8).
	Have Factory Authorized Service Agent check brushes and slip rings, and field excitation circuit.
Erratic weld output.	Check and tighten connections inside and outside unit.
	Be sure connection to work piece is clean and tight.
	Use dry, properly stored electrodes.
	Remove excessive coils from weld cables.
	Have Factory Authorized Service Agent check brushes and slip rings.
High weld output.	Check position of Ampere Range switch and Voltage/Amperage Adjust control.
	Check engine speed, and have engine manufacturer's factory authorized service agent adjust if necessary. See Section 9-6 for idle speed adjustment.
	Have Factory Authorized Service Agent check OCV control circuit.
Low weld output.	Check engine speed, and have engine manufacturer's factory authorized service agent adjust if necessary. See Section 9-6 for idle speed adjustment.
	Check fuses F1 and F2, and replace if open (see Section 9-8). Have Factory Authorized Service Agent check integrated rectifier SR1, capacitor C9, integrated rectifier SR2, and the rotor.
Electrode sticks to the workpiece more frequently during low voltage (short arc length) conditions.	Circuit breaker CB4 may be open. CB4 automatically resets when the fault is corrected (see Section 9-8). Have Factory Authorized Service Agent check transformer T1 and integrated rectifiers SR4 and SR5.
Low open-circuit voltage.	Check engine speed, and have engine manufacturer's factory authorized service agent adjust if necessary. See Section 9-6 for idle speed adjustment.
	Place Stick/TIG switch in Stick position.
Maximum weld output only in each ampere range (with Stick/TIG Selection switch in Stick position).	Have Factory Authorized Service Agent check control relay CR7.
No remote fine amperage control.	Place Amperage Adjust switch in Remote position.
	Check and secure connections to Remote Amperage Adjust receptacle RC13 (see Section 5-10).
	Reset supplementary protector CB11 (see Section 9-8). Have Factory Authorized Service Agent check control relay CR7.

Trouble	Remedy
No remote fine amperage control.	Repair or replace remote control device.
	Have Factory Authorized Service Agent check OCV control circuit.

B. Welding – CC/CV Models

Trouble	Remedy
No weld output; generator power output okay at ac receptacles.	Place Process/Contactor switch in a Weld Terminals Always On position, or place switch in a Remote On/Off Switch Required position and connect remote contactor to optional Remote 14 receptacle RC14 (see Sections 5-11 and 7-1).
	Check position of Ampere Range switch.
	Check position of optional Polarity switch or Polarity/AC switch.
	Reset supplementary protector CB11 (see Section 9-8).
	Reset supplementary protector CB5 (see Section 9-8). Check for faulty remote device connected to RC14.
	Check and secure connections to Remote 14 receptacle RC14 (see Section 5-11).
	Have Factory Authorized Service Agent check connector board PC6 and connections.
	Check fuse F2, and replace if open (see Section 9-8). Have Factory Authorized Service Agent check brushes and slip rings, weld excitation circuit, field current regulator board PC1, and the rotor.
No weld output or generator power output at ac receptacles.	Disconnect equipment from generator power receptacles during start-up.
	Check fuses F1 and F2, and replace if open (see Section 9-8). Have Factory Authorized Service Agent check integrated rectifier SR1, capacitor C9, field current regulator board PC1, and the rotor.
	Have Factory Authorized Service Agent check brushes and slip rings, and field excitation circuit.
Erratic weld output.	Check and tighten connections inside and outside unit.
	Be sure connection to work piece is clean and tight.
	Use dry, properly stored electrodes.
	Remove excessive coils from weld cables.
	Have Factory Authorized Service Agent check brushes and slip rings.
High weld output.	Check position of Ampere Range switch and Voltage/Amperage Adjust control.
	Check engine speed, and have engine manufacturer's factory authorized service agent adjust if necessary. See Section 9-6 for idle speed adjustment.
	Have Factory Authorized Service Agent check field current regulator board PC1, and PC1 voltage feedback circuit.
Voltage/Amperage control does not work when welding in Stick mode.	Place Ampere Range switch in lower range. Voltage/Amperage control does not work with Ampere Range switch in highest range.
Low weld output.	Check position of Ampere Range switch and Voltage/Amperage Adjust control.
	Check engine speed, and have engine manufacturer's factory authorized service agent adjust if necessary. See Section 9-6 for idle speed adjustment.
	Check fuses F1 and F2, and replace if open (see Section 9-8). Have Factory Authorized Service Agent check integrated rectifier SR1, capacitor C9, field current regulator board PC1, and the rotor.
Electrode sticks to the workpiece more frequently during low voltage (short arc length) conditions.	Circuit breaker CB4 may be open. CB4 automatically resets when the fault is corrected (see Section 9-8). Have Factory Authorized Service Agent check transformer T1 and integrated rectifiers SR4 and SR5.
Low open-circuit voltage.	Check engine speed, and have engine manufacturer's factory authorized service agent adjust if necessary. See Section 9-6 for idle speed adjustment.
	Check position of Process/Contactor switch.
No remote fine amperage or voltage control.	Place Voltage/Amperage Adjust switch in Remote position.
	Check and secure connections to Remote 14 receptacle RC14 (see Section 5-11).

Trouble	Remedy
No remote fine amperage or voltage control.	Repair or replace remote control device.
	Have Factory Authorized Service Agent check PC1 sensing leads (36 and 37), and connections.
Constant speed wire feeder does not work.	Reset supplementary protector CB5 or CB6 (see Section 9-8).
	Check and secure connections to Remote 14 receptacle RC14 (see Section 5-11).
	Repair or replace wire feeder.
Low CV weld output.	Set Ampere Range switch to highest range.
	Increase Voltage/Amperage Adjust Control setting.
Min or max CV weld output only.	Check position of Voltage/Amperage Adjust control and Voltage/Amperage Adjust switch.
	Repair or replace remote control device.
	Have Factory Authorized Service Agent check Amperage/Voltage Adjust Control R1, and field current regulator board PC1.

C. Standard Generator Power

Trouble	Remedy
No generator power output at ac receptacles; weld output okay.	Reset receptacle supplementary protectors.
	Reset GFCI receptacle.
No generator power or weld output.	Disconnect equipment from generator power receptacles during start-up.
	Check fuses F1 and F2, and replace if open (see Section 9-8). Have Factory Authorized Service Agent check integrated rectifier SR1, capacitor C9, diode/capacitor board D1/C1, and the rotor.
	Reset supplementary protector CB12. Have Factory Authorized Service Agent check diode D1 .
	Have Factory Authorized Service Agent check brushes and slip rings, and field excitation circuit.
High output at generator power ac receptacles.	Check engine speed, and have engine manufacturer's factory authorized service agent adjust if necessary. See Section 9-6 for idle speed adjustment.
	Have Factory Authorized Service Agent adjust generator power field current resistor R3.
Low output at generator power ac receptacles.	Check engine speed, and have engine manufacturer's factory authorized service agent adjust if necessary. See Section 9-6 for idle speed adjustment.
	Check fuse F1, and replace if open (see Section 9-8). Have Factory Authorized Service Agent check integrated rectifier SR1, resistor R3, and capacitor C9.

D. Optional Three-Phase Generator Power (CC/CV Models Only)

Trouble	Remedy
No or low output at optional three-phase generator/receptacle RC5.	Place Process/Contactor switch in Weld Terminals Always On - Stick position (see Section 7-3).
	Reset supplementary protector CB7(see Section 8-2).
	Reset supplementary protector CB5 (see Section 9-8).
	Check engine speed, and have engine manufacturer's factory authorized service agent adjust if necessary. See Section 9-6 for idle speed adjustment.
	Have Factory Authorized Service Agent check brushes and slip rings, and field current regulator board PC1.
High output at optional three-phase generator/receptacle RC5.	Check engine speed, and have engine manufacturer's factory authorized service agent adjust if necessary. See Section 9-6 for idle speed adjustment.
	Have Factory Authorized Service Agent check field current regulator board PC1, and PC1 voltage feedback circuit.
Erratic output at optional three-phase generator/receptacle RC5.	Have Factory Authorized Service Agent check brushes and slip rings, and field current regulator board PC1.

E. Engine

Trouble	Remedy
Engine will not crank.	Check battery, and replace if necessary.
	Check battery connections and tighten if necessary.
	Circuit breaker CB10 may be open. CB10 automatically resets when fault is corrected (see Section 9-8). Have Factory Authorized Service Agent check engine wiring harness and components.
	Check engine wiring harness plug connections.
	Have Factory Authorized Service Agent check control relay CR1 and Engine Control switch S1.
Engine cranks but does not start.	Check fuel level.
	Check battery and replace if necessary. Check engine charging system according to engine manual.
	Have Factory Authorized Service Agent check engine wiring harness, time delay relay TD1, control relay CR5, fuel pump, fuel solenoid FS1, and diode/capacitor board D10/C10.
	Air in fuel system. See engine manual.
Engine starts, but stops when Engine Control switch is released.	Check oil, and coolant levels. Automatic shutdown system stops engine if oil pressure is too low or coolant temperature is too high (see Section 5-7). Automatic shutdown system is inhibited for 30 seconds after start-up.
	Have Factory Authorized Service Agent check time delay relay TD1, and control relay CR5.
Engine hard to start in cold weather.	Use starting aid switch (see Section 6-1 or 7-1).
	Keep battery in good condition. Store battery in warm area off cold surface.
	Use fuel formulated for cold weather (diesel fuel can gel in cold weather). Contact local fuel supplier for fuel information.
	Use correct grade oil for cold weather (see Section 9-1).
Engine suddenly stops.	Check oil and coolant levels. Automatic shutdown system stops engine if oil pressure is too low or coolant temperature is too high (see Section 5-7). Automatic shutdown system is inhibited for 30 seconds after start-up.
	See engine manual.
Engine slowly stopped and cannot be restarted.	Check fuel level.
	Check engine air and fuel filters (see Sections 9-4 and 9-7).
	See engine manual.
Battery discharges between uses.	Turn Engine Control switch off when unit is not running.
	Clean top of battery with baking soda and water solution; rinse with clear water.
	Recharge or replace battery if necessary.
	Periodically recharge battery (approximately every 3 months).
Engine idles, but does not come up to weld speed (models with idle option only).	Have Factory Authorized Service Agent check idle module PC7 and current transformer CT1.
	Check for obstructed throttle solenoid.
Engine does not run at idle speed (models with idle option only).	CC models: place Stick/TIG Selection switch in Stick position. CC/CV models: place Process/Contactor switch in any position but Remote On/Off Switch Required-TIG.
	Check for obstructed throttle solenoid.
	Have Factory Authorized Service Agent check idle module PC7, and control relays CR3 and CR6.
Engine uses oil during run-in period; wetstacking occurs.	Dry engine according to run-in procedure (see Section 11).

SECTION 10 – ELECTRICAL DIAGRAMS

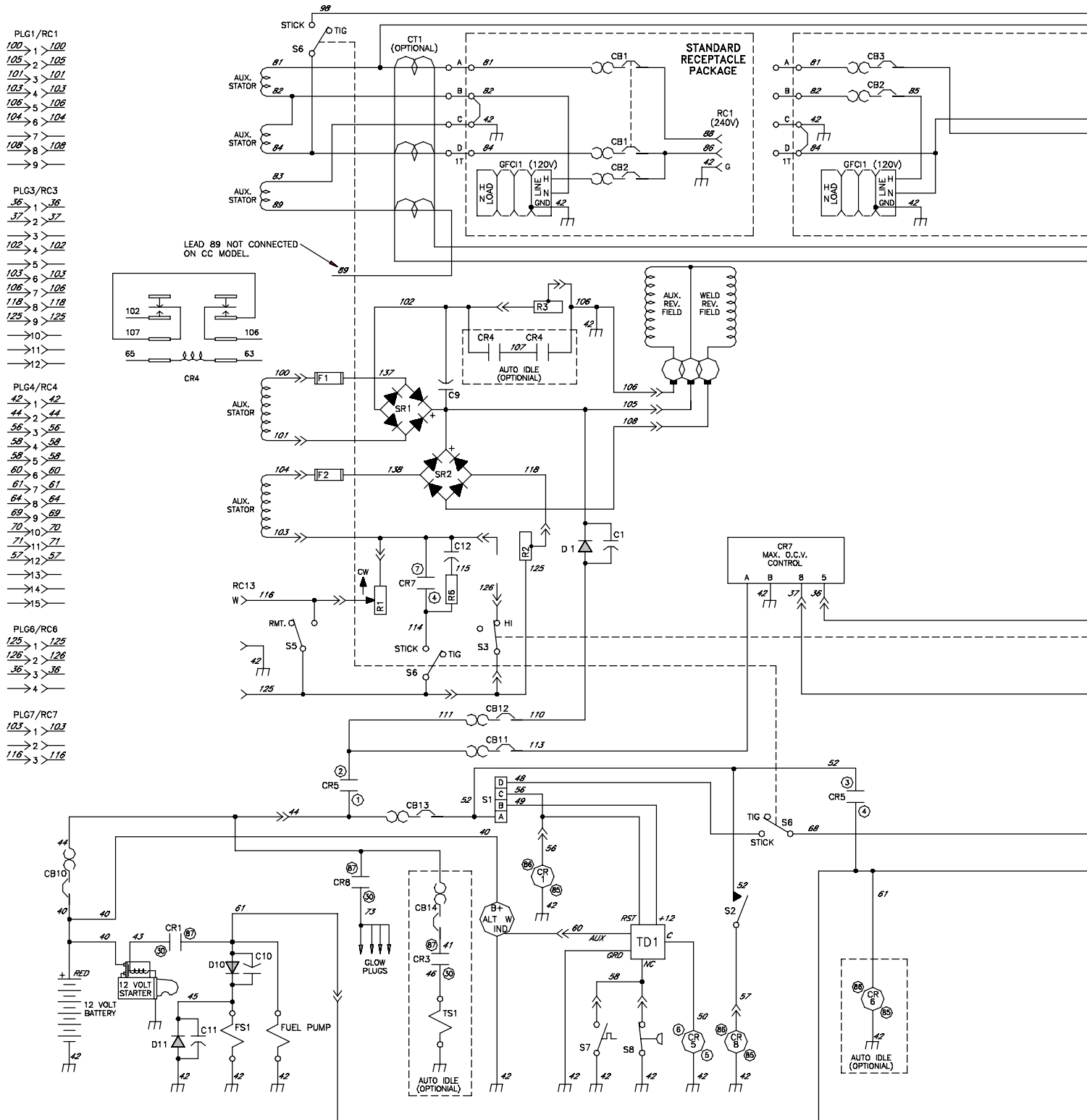
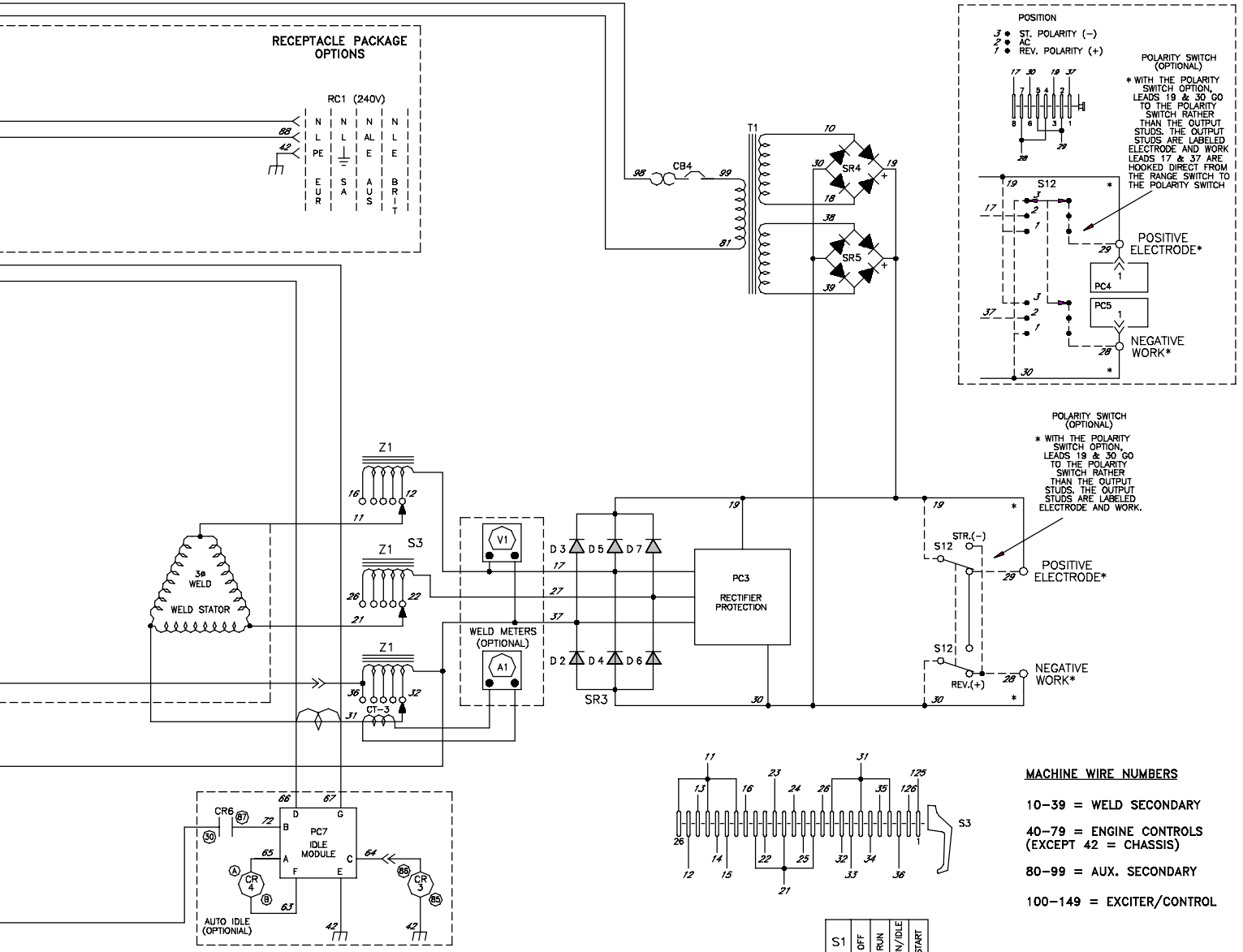

Figure 10-1. Circuit Diagram For CC Welding Generator



- Do not touch live electrical parts.
- Disconnect input power or stop engine before servicing.
- Do not operate with covers removed.
- Have only qualified persons install, use, or service this unit.



S1	OFF	RUN	RUN/IDLE	START
A		X	X	X
B		X	X	X
C				X
D			X	

X = CLOSED TO "A" TERMINAL

⚠ WARNING

- Do not touch live electrical parts.
- Disconnect input power or stop engine before servicing.
- Do not operate with covers removed.

ELECTRIC SHOCK HAZARD

- Have only qualified persons install, use, or service this unit.

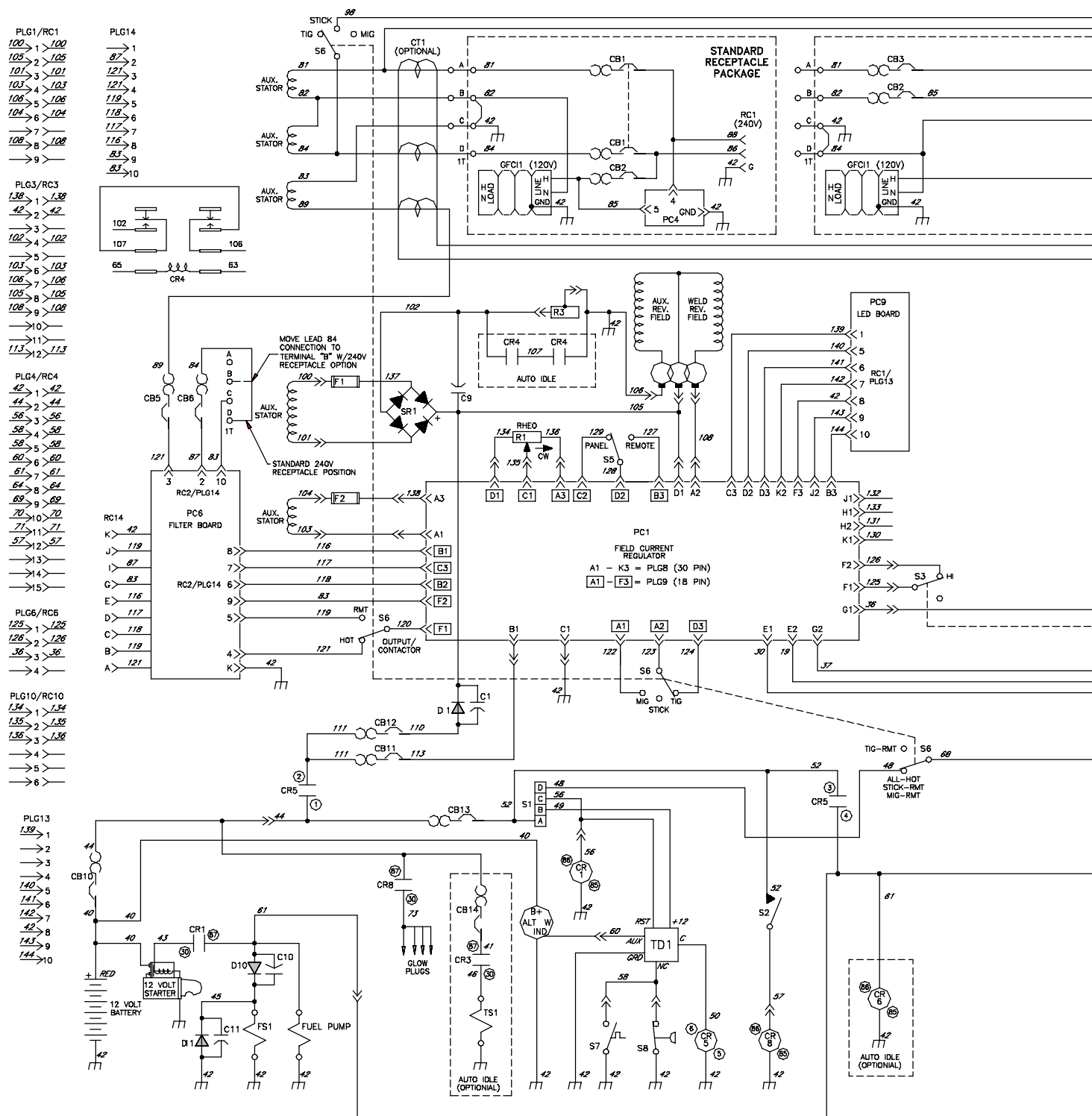
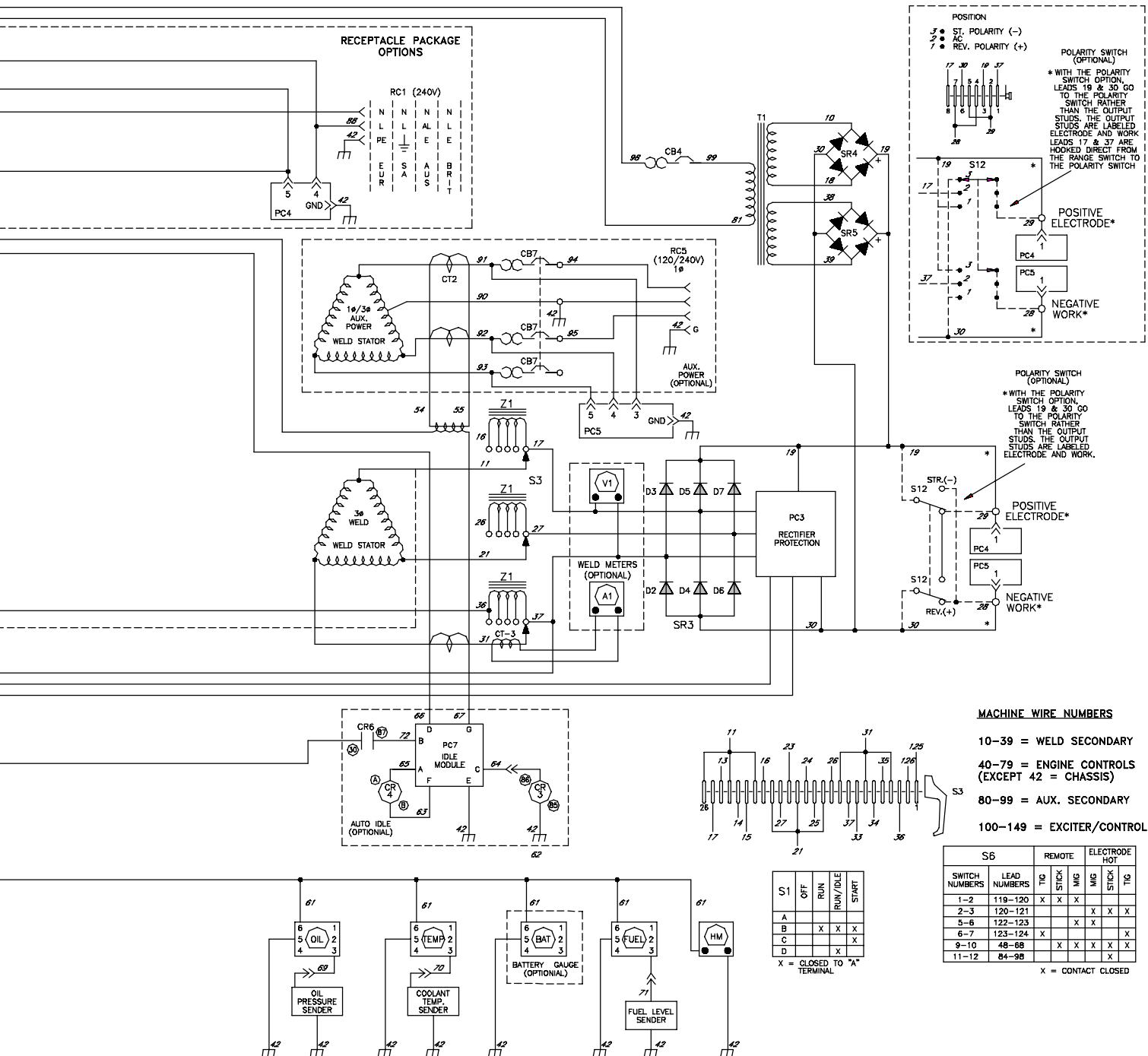

Figure 10-2. Circuit Diagram For CC/CV Welding Generator



SECTION 11 – RUN-IN PROCEDURE

run_in1 2007-04

11-1. Wetstacking

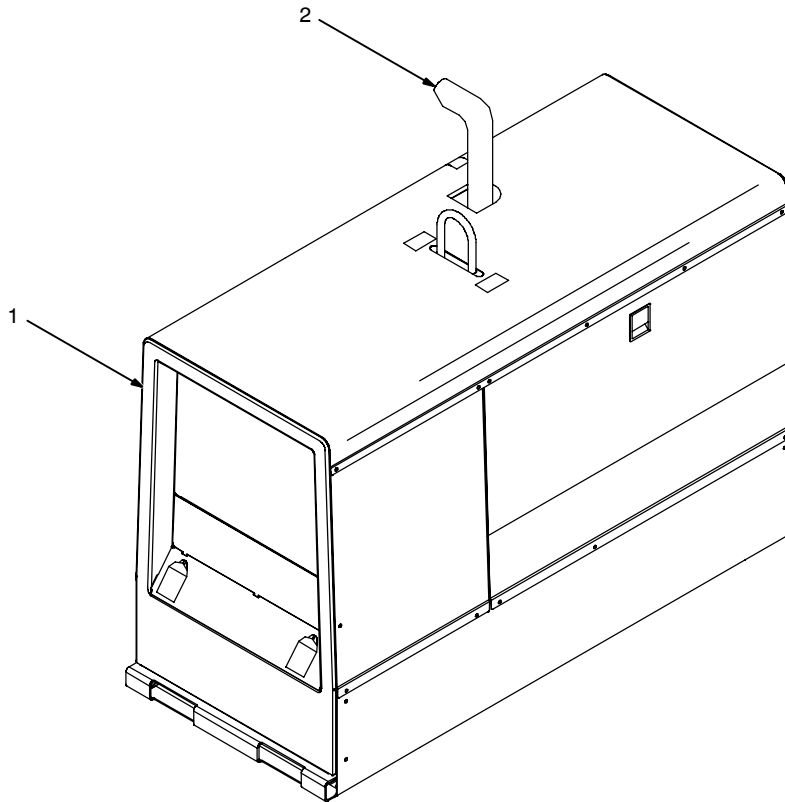

NOTICE – Do not perform run-in procedure at less than 20 volts weld output and do not exceed duty cycle or equipment damage may occur.

1 Welding Generator

Run diesel engines near rated voltage and current during run-in period to properly seat piston rings and prevent wetstacking. See nameplate, rating label, or specifications section in this manual to find rated voltage and current.

NOTICE – Do not idle engine longer than necessary. Piston rings seat faster if engine runs at weld/power rpm, and the welding generator is kept loaded during run-in.

2 Engine Exhaust Pipe

Wetstacking is unburned fuel and oil in the exhaust pipe and occurs during run-in if the engine is run too long at light load or idle rpm.

If exhaust pipe is coated with a wet, black, tar-like substance, dry the engine using one of the following run-in procedures.

See the engine manual for additional engine run-in information.

11-2. Run-In Procedure Using Load Bank

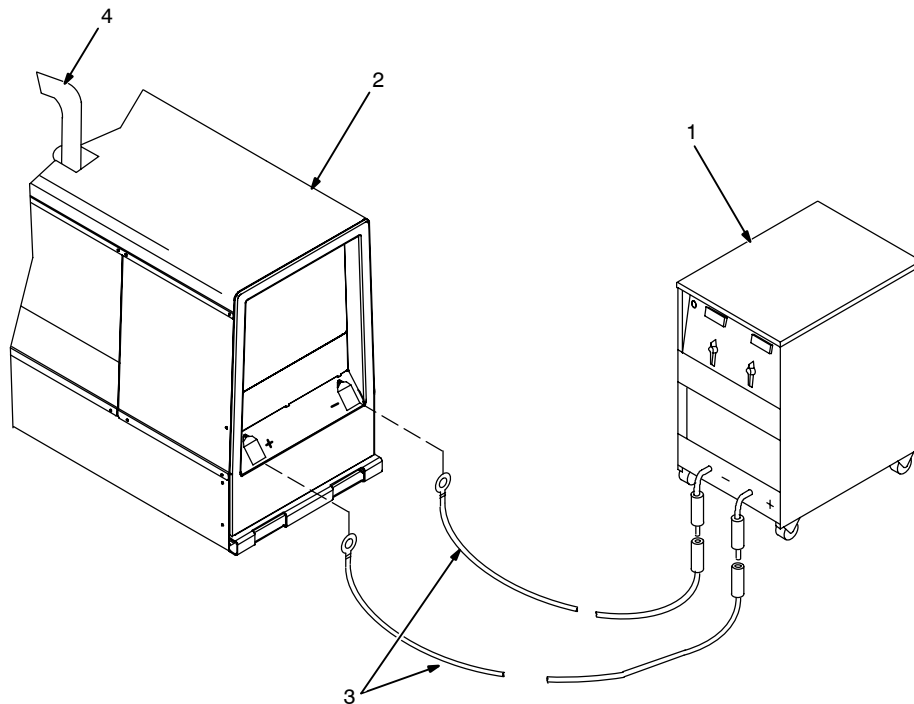

- ⚠ Stop engine.**
- ⚠ Do not touch hot exhaust pipe, engine parts, or load bank/grid.**
- ⚠ Keep exhaust and pipe away from flammables.**

NOTICE – Do not perform run-in procedure at less than 20 volts weld output and do not exceed duty cycle or equipment damage may occur.

1 Load Bank

Turn all load bank switches Off. If needed, connect load bank to 115 volts ac wall receptacle or generator auxiliary power receptacle.

2 Welding Generator

Place A/V range switch in maximum position, A/V control in minimum position, and Output Selector switch (if present) in either DC position.

3 Weld Cables

Connect load bank to generator weld output terminals using proper size weld cables with correct connectors. Observe correct polarity.

Start engine and run for several minutes.

Set load bank switches and then adjust generator A/V control so load equals rated voltage and current of generator (see nameplate, rating label, or the specifications section in this manual).

Check generator and load bank meters after first five minutes then every fifteen minutes to be sure generator is loaded properly.

NOTICE – Check oil level frequently during run-in; add oil if needed.

It is recommended to run the welding generator for two hours minimum and up to four hours under load. Place A/V control in minimum position, then turn off load bank to remove load. Run engine several minutes at no load.

- ⚠ Stop engine and let cool.**

4 Engine Exhaust Pipe

Repeat procedure if wetstacking is present.

11-3. Run-In Procedure Using Resistance Grid

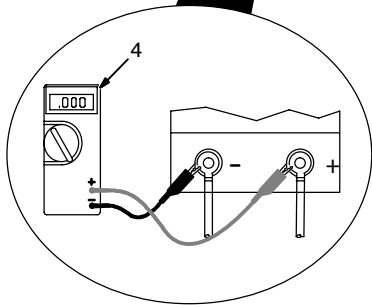
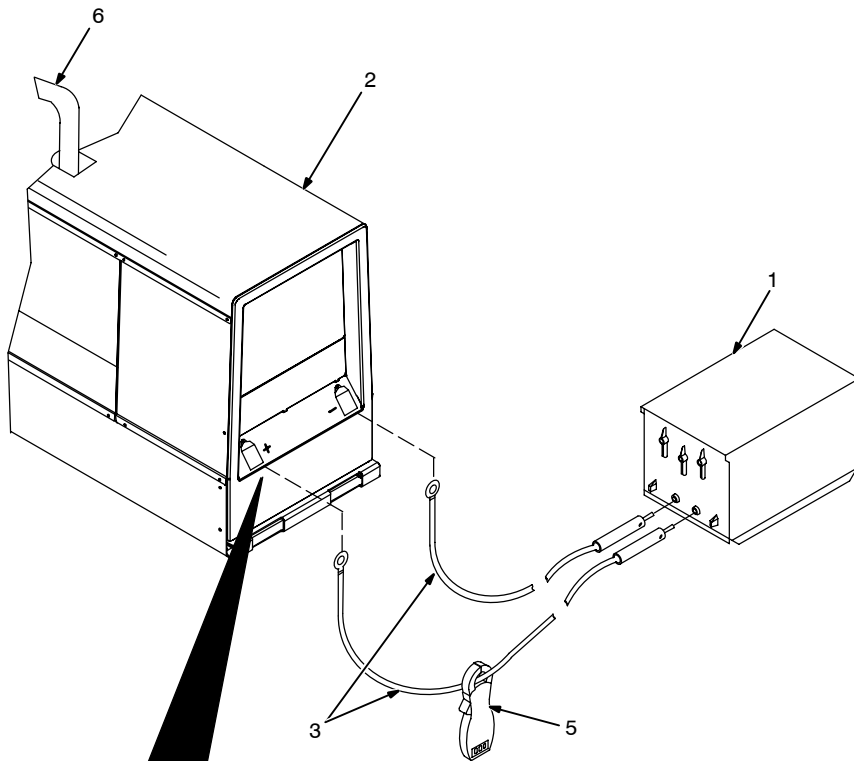

⚠ Stop engine.

⚠ Do not touch hot exhaust pipe, engine parts, or load bank/grid.

⚠ Keep exhaust and pipe away from flammables.

NOTICE – Do not perform run-in procedure at less than 20 volts weld output and do not exceed duty cycle or equipment damage may occur.

1 Resistance Grid

Use grid sized for generator rated output.

Turn Off grid.

2 Welding Generator

Place A/V range switch in maximum position, A/V control in minimum position, and Output Selector switch (if present) in either DC position.

3 Weld Cables

Connect grid to generator weld output terminals using proper size weld cables with correct connectors (polarity is not important).

4 Voltmeter

5 Clamp-On Ammeter

Connect voltmeter and ammeter as shown, if not provided on generator.

Start engine and run for several minutes.

Set grid switches and then adjust generator A/V control so load equals rated voltage and current of the generator (see nameplate, rating label, or the specifications section in this manual).

Check generator and meters after first five minutes then every fifteen minutes to be sure generator is loaded properly.

NOTICE – Check oil level frequently during run-in; add oil if needed.

It is recommended to run the welding generator for two hours minimum and up to four hours under load. Place A/V control in minimum position, then shut down grid to remove load. Run engine several minutes at no load.

⚠ Stop engine and let cool.



6 Engine Exhaust Pipe

Repeat procedure if wetstacking is present.

SECTION 12 – GENERATOR POWER GUIDELINES

The views in this section are intended to be representative of all engine-driven welding generators. Your unit may differ from those shown.

12-1. Selecting Equipment



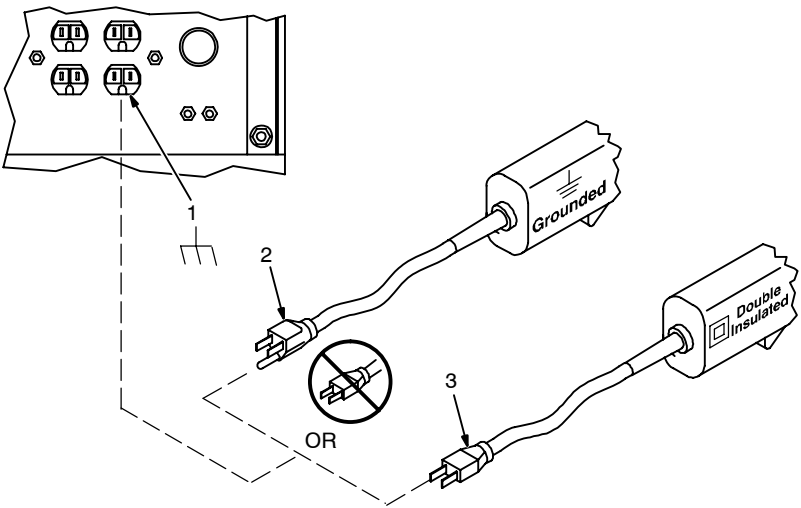

- 1 Generator Power Receptacles – Neutral Bonded To Frame
- 2 3-Prong Plug From Case Grounded Equipment
- 3 2-Prong Plug From Double Insulated Equipment

Be sure equipment has double insulated symbol and/or wording on it.

Do not use 2-prong plug unless equipment is double insulated.

gen_pwr 2007-04 – Ref. ST-159 730 / ST-800 577

12-2. Grounding Generator To Truck Or Trailer Frame

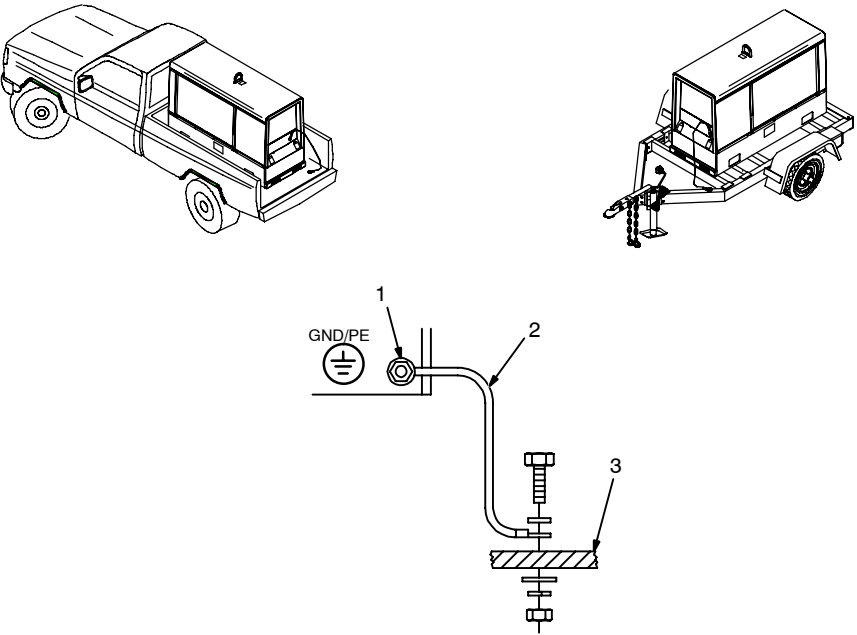

Always ground generator frame to vehicle frame to prevent electric shock and static electricity hazards.

Also see AWS Safety & Health Fact Sheet No. 29, Grounding of Portable And Vehicle Mounted Welding Generators.

- 1 Equipment Grounding Terminal (On Front Panel)
- 2 Grounding Cable (Not Supplied)
- 3 Metal Vehicle Frame

Connect cable from equipment ground terminal to metal vehicle frame. Use #10 AWG or larger insulated copper wire.

Electrically bond generator frame to vehicle frame by metal-to-metal contact.

Bed liners, shipping skids, and some running gear insulate the welding generator from the vehicle frame. Always connect a ground wire from the generator equipment grounding terminal to bare metal on the vehicle frame as shown.

If unit does not have GFCI receptacles, use GFCI-protected extension cord.

S-0854

12-3. Grounding When Supplying Building Systems

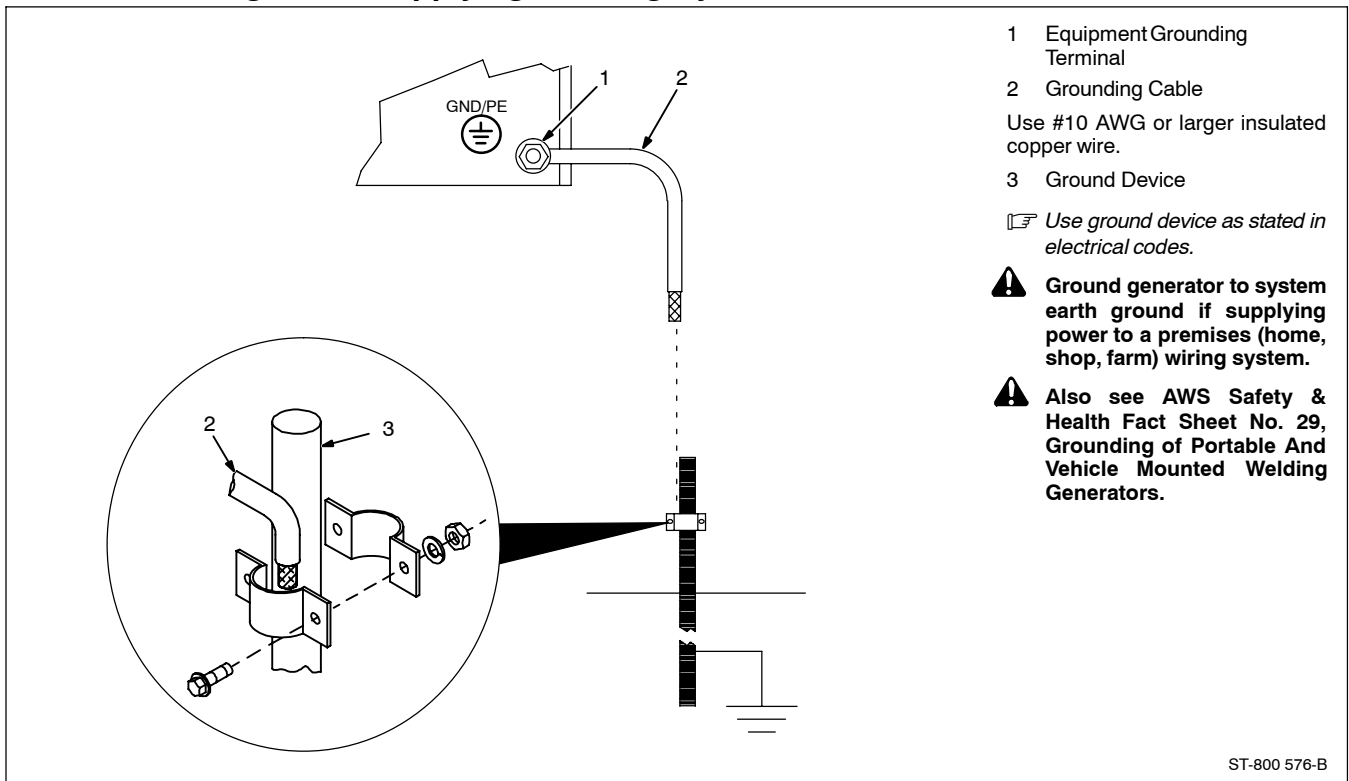

1 Equipment Grounding Terminal

2 Grounding Cable

Use #10 AWG or larger insulated copper wire.

3 Ground Device

Use ground device as stated in electrical codes.

Ground generator to system earth ground if supplying power to a premises (home, shop, farm) wiring system.

Also see AWS Safety & Health Fact Sheet No. 29, Grounding of Portable And Vehicle Mounted Welding Generators.

ST-800 576-B

12-4. How Much Power Does Equipment Require?

1 Resistive Load

A light bulb is a resistive load and requires a constant amount of power.

2 Non-Resistive Load

Equipment with a motor is a non-resistive load and requires approximately six times more power while starting the motor than when running (see Section 12-8).

3 Rating Data

Rating shows volts and amperes, or watts required to run equipment.

Amperes x Volts = Watts

Example 1: If a drill uses 4.5 amperes at 115 volts, calculate its running power requirement in watts.

$$4.5 \text{ A} \times 115 \text{ V} = 520 \text{ W}$$

The load applied by the drill is 520 watts.

Example 2: If three 200 watt flood lamps are used with the drill from Example 1, add the individual loads to calculate total load.

$$(3 \times 200\text{W}) + 520 \text{ W} = 1120 \text{ W}$$

The total load applied by the three flood lamps and drill is 1120 watts.

S-0623

12-5. Approximate Power Requirements For Industrial Motors

Industrial Motors	Rating	Starting Watts	Running Watts
Split Phase	1/8 HP	800	300
	1/6 HP	1225	500
	1/4 HP	1600	600
	1/3 HP	2100	700
	1/2 HP	3175	875
Capacitor Start-Induction Run	1/3 HP	2020	720
	1/2 HP	3075	975
	3/4 HP	4500	1400
	1 HP	6100	1600
	1-1/2 HP	8200	2200
	2 HP	10550	2850
	3 HP	15900	3900
Capacitor Start-Capacitor Run	5 HP	23300	6800
	1-1/2 HP	8100	2000
	5 HP	23300	6000
	7-1/2 HP	35000	8000
Fan Duty	10 HP	46700	10700
	1/8 HP	1000	400
	1/6 HP	1400	550
	1/4 HP	1850	650
	1/3 HP	2400	800
	1/2 HP	3500	1100

12-6. Approximate Power Requirements For Farm/Home Equipment

Farm/Home Equipment	Rating	Starting Watts	Running Watts
Stock Tank De-Icer		1000	1000
Grain Cleaner	1/4 HP	1650	650
Portable Conveyor	1/2 HP	3400	1000
Grain Elevator	3/4 HP	4400	1400
Milk Cooler		2900	1100
Milker (Vacuum Pump)	2 HP	10500	2800
FARM DUTY MOTORS	1/3 HP	1720	720
Std. (e.g. Conveyors,	1/2 HP	2575	975
Feed Augers, Air	3/4 HP	4500	1400
Compressors)	1 HP	6100	1600
	1-1/2 HP	8200	2200
	2 HP	10550	2850
	3 HP	15900	3900
	5 HP	23300	6800
High Torque (e.g. Barn	1-1/2 HP	8100	2000
Cleaners, Silo Unloaders,	5 HP	23300	6000
Silo Hoists, Bunk Feeders)	7-1/2 HP	35000	8000
	10 HP	46700	10700
3-1/2 cu. ft. Mixer	1/2 HP	3300	1000
High Pressure 1.8 Gal/Min	500 PSI	3150	950
Washer 2 gal/min	550 PSI	4500	1400
2 gal/min	700 PSI	6100	1600
Refrigerator or Freezer		3100	800
Shallow Well Pump	1/3 HP	2150	750
	1/2 HP	3100	1000
Sump Pump	1/3 HP	2100	800
	1/2 HP	3200	1050

12-7. Approximate Power Requirements For Contractor Equipment

Contractor	Rating	Starting Watts	Running Watts
Hand Drill	1/4 in	350	350
	3/8 in	400	400
	1/2 in	600	600
Circular Saw	6-1/2 in	500	500
	7-1/4 in	900	900
	8-1/4 in	1400	1400
Table Saw	9 in	4500	1500
	10 in	6300	1800
Band Saw	14 in	2500	1100
Bench Grinder	6 in	1720	720
	8 in	3900	1400
	10 in	5200	1600
Air Compressor	1/2 HP	3000	1000
	1 HP	6000	1500
	1-1/2 HP	8200	2200
	2 HP	10500	2800
Electric Chain Saw	1-1/2 HP, 12 in	1100	1100
	2 HP, 14 in	1100	1100
Electric Trimmer	Standard 9 in	350	350
	Heavy Duty 12 in	500	500
Electric Cultivator	1/3 HP	2100	700
Elec. Hedge Trimmer	18 in	400	400
Flood Lights	HID	125	100
	Metal Halide	313	250
	Mercury	1000	
	Sodium Vapor	1400	1000
Submersible Pump	400 gph	600	200
Centrifugal Pump	900 gph	900	500
Floor Polisher	3/4 HP, 16 in	4500	1400
	1 HP, 20 in	6100	1600
High Pressure Washer	1/2 HP	3150	950
	3/4 HP	4500	1400
	1 HP	6100	1600
55 gal Drum Mixer	1/4 HP	1900	700
Wet & Dry Vac	1.7 HP	900	900
	2-1/2 HP	1300	1300

12-8. Power Required To Start Motor

Single-Phase Induction Motor Starting Requirements								
Motor Start Code	G	H	J	K	L	M	N	P
KVA/HP	6.3	7.1	8.0	9.0	10.0	11.2	12.5	14.0

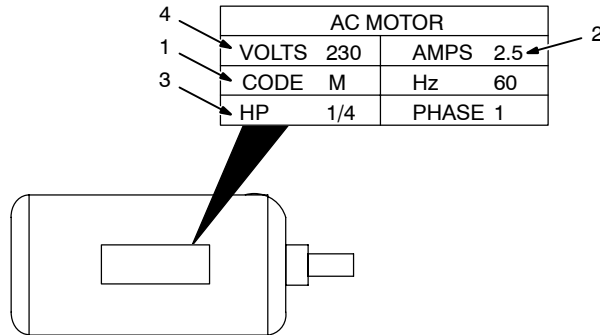

- 1 Motor Start Code
- 2 Running Amperage
- 3 Motor HP
- 4 Motor Voltage

To find starting amperage:

Step 1: Find code and use table to find kVA/HP. If code is not listed, multiply running amperage by six to find starting amperage.

Step 2: Find Motor HP and Volts.

Step 3: Determine starting amperage (see example).

Welding generator amperage output must be at least twice the motor's running amperage.

$$\frac{(\text{kVA/HP} \times \text{HP} \times 1000)}{\text{Volts}} = \text{Starting Amperage}$$

Example: Calculate starting amperage required for a 230 V, 1/4 HP motor with a motor start code of M.

Volts = 230, HP = 1/4, kVA/HP = 11.2

$$(11.2 \times 1/4 \times 1000) / 230 = 12.2\text{A}$$

Starting the motor requires 12.2 amperes.

S-0624

12-9. How Much Power Can Generator Supply?

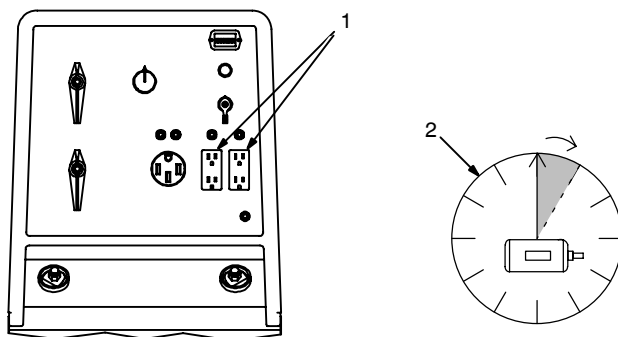

- 1 Limit Load To 90% Of Generator Output

Always start non-resistive (motor) loads in order from largest to smallest, and add resistive loads last.

- 2 5 Second Rule

If motor does not start within 5 seconds, turn off power to prevent motor damage. Motor requires more power than generator can supply.

Ref. ST-800 396-A / S-0625

12-10. Typical Connections To Supply Standby Power

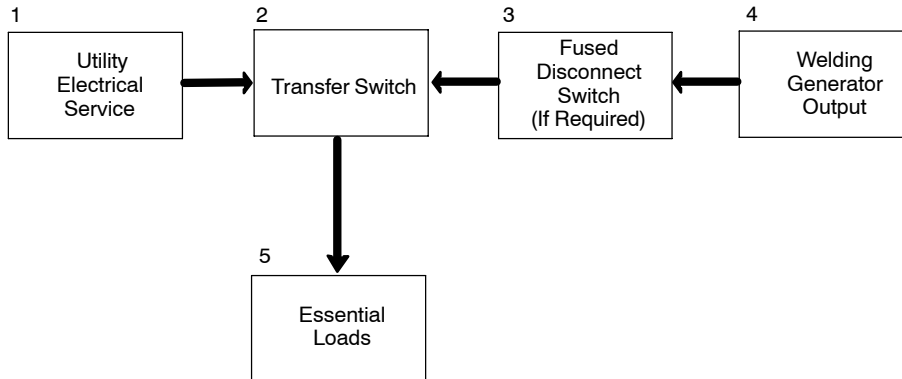

⚠ Have only qualified persons perform these connections according to all applicable codes and safety practices.

⚠ Properly install and ground this equipment according to its Owner's Manual and national, state, and local codes.

📖 Customer-supplied equipment is required if generator will supply standby power during emergencies or power outages.

1 Utility Electrical Service

2 Transfer Switch (Double-Throw)

Switch transfers the electrical load from electric utility service to the generator. Transfer load back to electric utility when service is restored.

Install correct switch (customer-supplied). Switch rating must be same as or greater than the branch overcurrent protection.

3 Fused Disconnect Switch

Install correct switch (customer-supplied) if required by electrical code.

4 Welding Generator Output

Generator output voltage and wiring must be consistent with regular (utility) system voltage and wiring.

Connect generator with temporary or permanent wiring suitable for the installation.

Turn off or unplug all equipment connected to generator before starting or stopping engine. When starting or stopping, the engine has low speed which causes low voltage and frequency.

5 Essential Loads

Generator output may not meet the electrical requirements of the premises. If generator does not produce enough output to meet all requirements, connect only essential loads (pumps, freezers, heaters, etc. – See Section 12-4).

12-11. Selecting Extension Cord (Use Shortest Cord Possible)



Cord Lengths for 120 Volt Loads							
 If unit does not have GFCI receptacles, use GFCI-protected extension cord.							
Current (Amperes)	Load (Watts)	Maximum Allowable Cord Length in ft (m) for Conductor Size (AWG)*					
		4	6	8	10	12	14
5	600			350 (106)	225 (68)	137 (42)	100 (30)
7	840		400 (122)	250 (76)	150 (46)	100 (30)	62 (19)
10	1200	400 (122)	275 (84)	175 (53)	112 (34)	62 (19)	50 (15)
15	1800	300 (91)	175 (53)	112 (34)	75 (23)	37 (11)	30 (9)
20	2400	225 (68)	137 (42)	87 (26)	50 (15)	30 (9)	
25	3000	175 (53)	112 (34)	62 (19)	37 (11)		
30	3600	150 (46)	87 (26)	50 (15)	37 (11)		
35	4200	125 (38)	75 (23)	50 (15)			
40	4800	112 (34)	62 (19)	37 (11)			
45	5400	100 (30)	62 (19)				
50	6000	87 (26)	50 (15)				

*Conductor size is based on maximum 2% voltage drop

Cord Lengths for 240 Volt Loads							
 If unit does not have GFCI receptacles, use GFCI-protected extension cord.							
Current (Amperes)	Load (Watts)	Maximum Allowable Cord Length in ft (m) for Conductor Size (AWG)*					
		4	6	8	10	12	14
5	1200			700 (213)	450 (137)	225 (84)	200 (61)
7	1680		800 (244)	500 (152)	300 (91)	200 (61)	125 (38)
10	2400	800 (244)	550 (168)	350 (107)	225 (69)	125 (38)	100 (31)
15	3600	600 (183)	350 (107)	225 (69)	150 (46)	75 (23)	60 (18)
20	4800	450 (137)	275 (84)	175 (53)	100 (31)	60 (18)	
25	6000	350 (107)	225 (69)	125 (38)	75 (23)		
30	7000	300 (91)	175 (53)	100 (31)	75 (23)		
35	8400	250 (76)	150 (46)	100 (31)			
40	9600	225 (69)	125 (38)	75 (23)			
45	10,800	200 (61)	125 (38)				
50	12,000	175 (53)	100 (31)				

*Conductor size is based on maximum 2% voltage drop

SECTION 13 – PARTS LIST

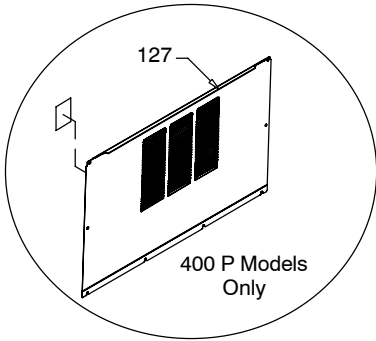

 Hardware is common and not available unless listed.

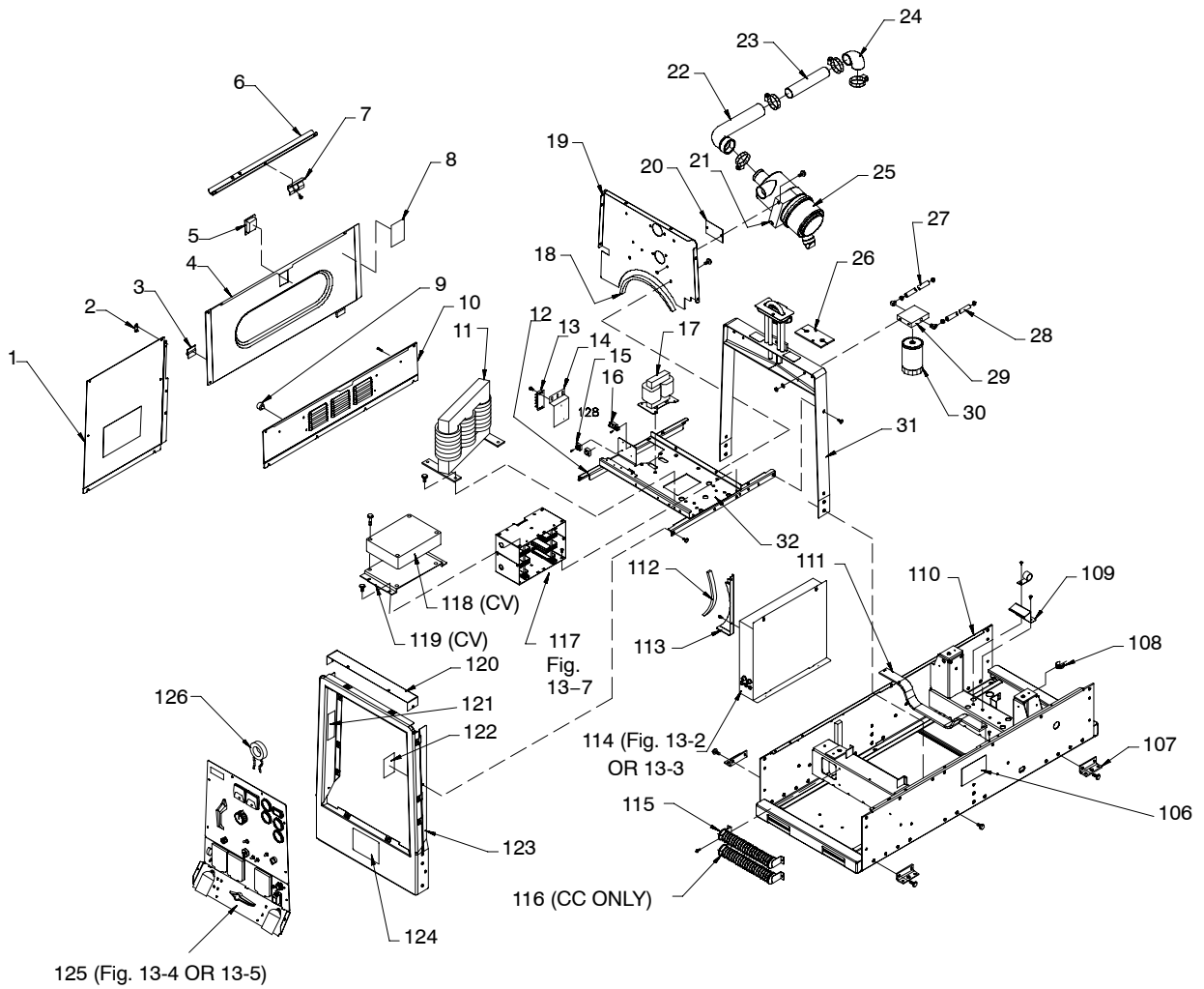
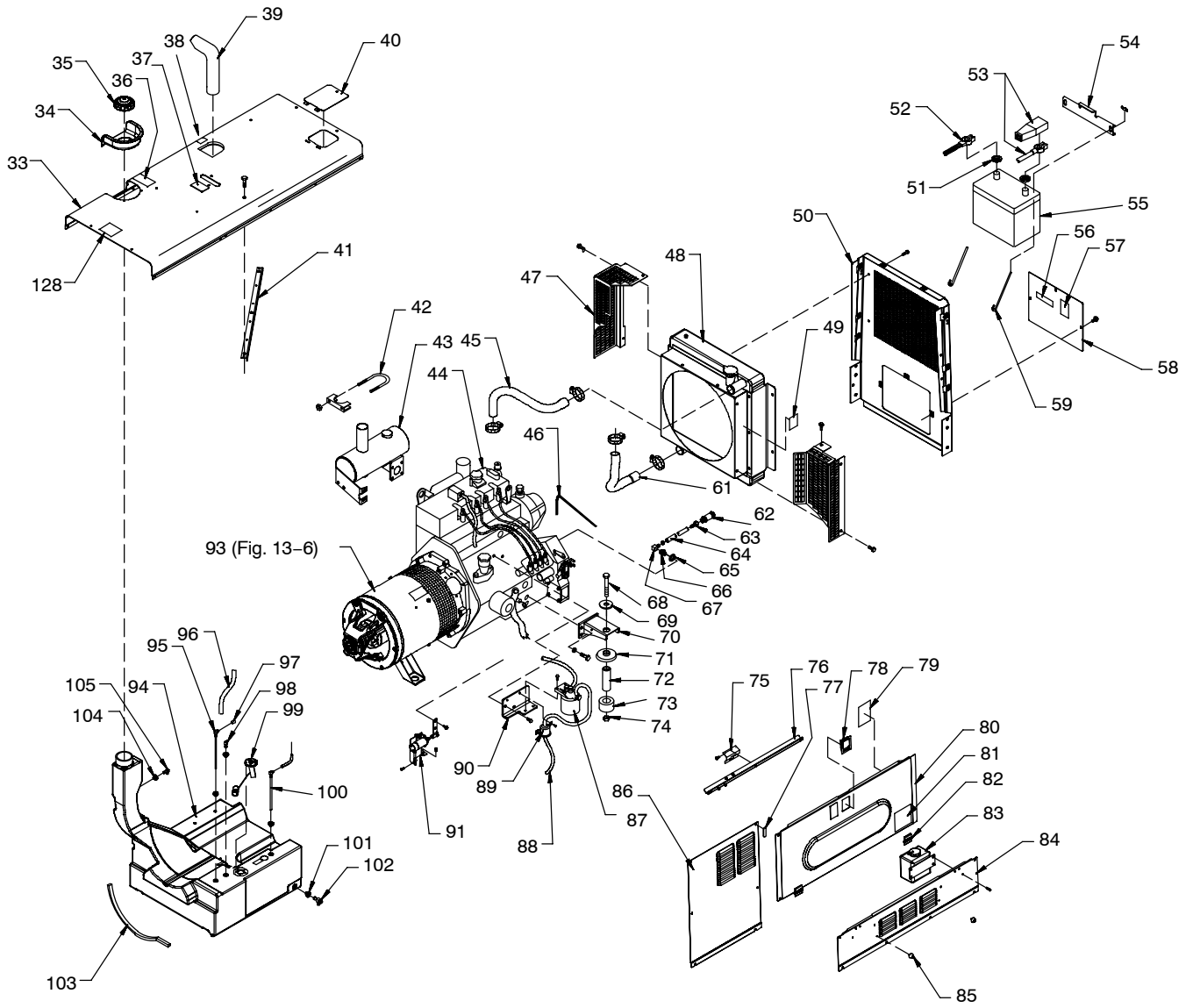

Figure 13-1. Main Assembly (Export Model Shown)



Item No.	Dia. Mkgs.	Part No.	Description	Quantity
Figure 13-1. Main Assembly				
...	1	189 824	PANEL, gen LH	1
...	1	◆199 294	PANEL, gen LH ss	1
...	2	191 626	BUMPER, door engine access	2
...	3	189 975	HINGE, door access 180deg	2
...	4	+200 989	DOOR, engine access	1
...	4	◆+210 736	DOOR, engine access ss	1
...	5	199 592	LATCH, paddle series 20 (black)	1
...	6	190 076	CHANNEL, stiffener engine access	1
...	6	◆202 635	CHANNEL, stiffener engine access e-coat	1
...	7	190 992	KEEPER, latch engine access door	1
...	8	220539	LABEL, diesel engine maintenance (required on rh door only)	1
...	9	208 141	STOP, door	1
...	10	189 826	PANEL, rocker	1
...	10	◆199 298	PANEL, rocker ss	1
...	11	Z1 c _c 214 972	REACTOR, ac	1
...	11	Z1 c _v 214 964	REACTOR, ac	1
...	12	206 352	BRACE, front to center upright	2
...	13	1T 038 621	BLOCK, term 30A 4 pole frict term str	1
...		038 620	LINK, jumper term blk 30A	2
...	14	081 499	BRACKET, mtg strip terminal	1
...	15	SR4, SR5 035 704	RECTIFIER, integ bridge 40. amp 800v	2
...	16	CB4 045 061	CIRCUIT BREAKER, auto reset 24vdc 7 amp	1
...	17	T1 201 613	TRANSFORMER w/bracket	1
...	17	T1 ◆205 636	TRANSFORMER w/bracket (environmental coating)	1
...	18	173 352	EXTRUSION, rubber clamp/bulb (order by ft)	3ft
...	19	189 708	FIREWALL, top	1
...	20	191 307	COVER, plate	1
...	21	189 763	BRACKET, mtg air cleaner	1
...	22	189 618	HOSE, air cleaner	1
...	23	198 457	TUBE, air intake	1
...	24	173 036	HOSE, elbow air cleaner	1
...		010 863	CLAMP, hose 1.125 – 3.000 clp dia	4
...	25	189 764	AIR CLEANER, intake	1
...		*192 938	FILTER, air element primary	1
...		*◆192 939	FILTER, air element safety	1
...	26	189 464	SEAL, weather lift eye	1
...		173 909	HOSE, sae .312 id x .560 od x 24.000 (order by ft)	2
...	27	191 819	HOSE, sae .312 id x .560 od x 14.000 (order by ft)	2
...		198 584	HOSE, sae .312 id x .560 od x 5.000 (order by ft)	1
...	28	095 636	HOSE, sae .187 id x .41 od x 30.000 (order by ft)	1
...	29	206 297	BASE, fuel filter w/fittings	1
...		192 741	BLOCK, spacer mtg filter base	1
...	30	*192 744	FILTER, fuel spin-on	1
...	31	201 658	UPRIGHT, center assembly	1
...	32	201 697	PAN, reactor and rectifier	1
...		203 260	LABEL, caution do not use ether	1
...	33	+201 934	COVER, top	1
...	33	◆+202 640	COVER, top ss	1
...	34	189 052	GROMMET, plastic neck filler fuel	1
...	35	190 198	CAP, tank screw-on 3.500 in w/vent	1
...	36	192 041	LABEL, use diesel fuel only	1
...	37	222 513	LABEL, warning falling equipment can cause serious	1
...	38	224 265	LABEL, warning hot exhaust parts do not touch	1
...	39	105 734	PIPE, muffler extension elbow 1.750 od	1
...	40	201 851	COVER, radiator access	1

Item No.	Dia. Mkgs.	Part No.	Description	Quantity
----------	------------	----------	-------------	----------

Figure 13-1. Main Assembly (Continued)

40		◆202 629	COVER, radiator access ss	1
41		191 354	SUPPORT, cover	1
41		◆202 633	SUPPORT, cover e-coat	1
42		010 875	CLAMP, muffler 2.000 dia	1
43		203 180	MANIFOLD, exhaust muffler	1
		203 179	BRACKET, support muffler	2
43		195 012	SPARK ARRESTOR KIT (Horizontal) (export models only)	1
44		209 393	ENGINE, Perkins dsl elec 404.22bw	1
		*214 931	SENDER, Coolant Temp & 110c N.o. Switch	1
		*215 094	SWITCH, oil pressure	1
		023 562	CLAMP, hose .312 - .875 clp dia	1
		*197 899	FILTER, oil	1
		*192 744	FILTER, fuel spin-on	1
		*197 997	FILTER, fuel secondary	1
45		214 658	HOSE, radiator upper	1
46		*197 944	BELT, fan	1
47		217 775	GUARD, belt (export models only)	1
47		202 017	GUARD, belt	1
48		220 280	RADIATOR, w/shroud (includes)	1
		220 281	SHROUD, radiator	1
		214 884	RADIATOR, w/14# cap 4 row core 3 pass	1
		187 120	CAP, radiator pressure 14 lb	1
49		225 120	LABEL, warning moving parts can cause injury	1
50		201 749	UPRIGHT, rear	1
50		◆207 188	UPRIGHT, rear ss	1
50		◆207 005	GRILL, rear panel ss	1
51		108 081	TERMINAL PROTECTOR, battery post mtg	2
52		190 206	CABLE, bat neg 42 in lg No. 2 awg w/clamp and .375rng	1
53		190 207	CABLE, bat pos 45 in lg No. 1 awg w/clamp and .406rng	1
54		203 430	BRACKET, battery holddown	1
55		190 897	BATTERY, stor 12V 650crk 110rsv gp 24	1
56		168 385	LABEL, warning battery explosion can blind	1
57		+225 120	LABEL, warning moving parts can cause injury	1
58		+201 183	COVER, battery access	1
58		◆+202 639	COVER, battery access ss	1
59		201 006	BOLT, j stl .312-18 x 8.500 pld	2
60		+215 006	GUARD, fan	1
61		197 496	HOSE, radiator lower	1
		199 505	HOSE, oil drain assy 32 in (consisting of)	1
62		165 271	VALVE, oil drain 3/8-18NPTF	1
63		176 529	FITTING, hose brs barbed fem 1/2tbg x 3/8NPT	1
64		113 854	HOSE, SAE .500 ID x .780 OD xc oil (order by ft)	3ft
65		197 448	FITTING, hose brs barbed elbow m 1/2 tbg x 3/8 npt	1
66			WASHER, oil drain (available through engine manufacturer)	1
67		197 196	FITTING, adapter oil drain 12mm male x 3/8 npt female	1
68		199 849	SCREW, 625-11 x 4.00hexhd pln gr 5 pld	4
69		071 731	WASHER, flat .656 ID x 2.250 OD x .187T stl pld	4
70		197 489	BRACKET, mtg RH	1
70		197 488	BRACKET, mtg LH	1
71		071 890	RETAINER, mount eng/gen	4
72		071 730	TUBING, stl .875 OD x 12ga wall x 2.500	4
73		083 476	MOUNT, eng/gen nprn .875 ID x 2.500 OD x 2.000	4
74		135 205	NUT, 625-11 .94hex .76H stl pld elastic stop nut	4
75		190 992	KEEPER, latch engine access door	2
76		190 076	CHANNEL, stiffener engine access	2
76		◆202 635	CHANNEL, stiffener engine access e-coat	1

Item No.	Dia. Mkgs.	Part No.	Description	Quantity
----------	------------	----------	-------------	----------

Figure 13-1. Main Assembly (Continued)

77		191 626	BUMPER, door engine access	4
78		199 592	LATCH, paddle series 20 (black)	1
79		220 539	LABEL, diesel engine maintenance	1
80		+200 989	DOOR, engine access	1
81		◆+210 736	DOOR, engine access ss	1
81			Not Applicable for Perkins powered machines	
82		189 975	HINGE, door access 180deg	2
		◆+199 301	PANEL, engine side ss	1
83		190 190	TANK, coolant recovery	1
84		189 826	PANEL, rocker	1
85		◆199 298	PANEL, rocker ss	1
85		208 141	STOP, door	1
86		189 827	PANEL, gen RH	1
87		◆199 300	PANEL, gen RH ss	1
87		*197 997	FILTER, fuel secondary	1
88		173 909	HOSE, sae .312 id x .560 od (order by ft)	1
89			PUMP, fuel (available through engine manufacturer)	1
90		218 222	BRACKET, mtg fuel filter/pump	1
91		◆230 636	IDLE SOLENOID ASSEMBLY (consisting of)	1
		230 634	SOLENOID, throttle w/4-8.4 lb spring	1
		230 829	BRACKET, mtg solenoid	1
		198 018	LINKAGE, throttle solenoid	1
		230 830	ARM, Throttle	1
		198 109	SCREW, shld stl sch .250-20 x .437 x .500 shld	1
92		225 120	LABEL, warning moving parts can cause injury	2
93		Figure13-6	GENERATOR	1
94		218 087	TANK, fuel (consisting of)	1
95		189 909	FITTING, stand pipe hose .250 x 9.260 lg 90deg zinc	1
96		095 636	HOSE, sae .187 id x .410 od x 30.000 (order by ft)	1
97		201 025	CAP, fuel fitting	1
98		189 913	FITTING, stl barbed elbow zinc pld	1
99		190 142	SENDER, fuel gauge 9.7500 deep tank	1
100		189 910	FITTING, stand pipe hose .3125 x 9.260 lg 90deg zinc	1
101		181 572	BUSHING, tank fuel	1
102		189 908	VALVE, drain fuel 180deg	1
103		191 446	EXTRUSION, rubber w/adhesive 1.000 x 1.000 D (order by ft)	6ft
104		124 253	BUSHING, tank fuel	4
		084 173	CLAMP, hose .460 - .545clp dia slftng	2
105		189 912	FITTING, stl barbed elbow w/.047 in orf zinc pld	1
106		224 266	LABEL, warning do not weld on base	2
107		191 897	BRACKET, mtg unit	4
108		192 362	BRACKET, mtg nyl 1/2 conduit	1
109		196 220	BRACKET, hold down fuel tank rear	1
110		+200 999	BASE	1
110		◆+203 382	BASE e-coat	1
111		218 086	BRACKET, hold down fuel tank	1
112		173 352	EXTRUSION, rubber clamp/bulb (order by ft)	3ft
113		189 731	FIREWALL, lower	1
114		Figures 13-2, 13-3	CONTROL BOX ASSEMBLY	1
115	R3	c ₁₈₉ 699	RESISTOR, WW tap 375W 10 ohm w/mtg bkt	1
116	R2	c ₁₈₉ 699	RESISTOR, WW tap 375W 10 ohm w/mtg bkt	1
117		Figure 13-7	MAIN RECTIFIER ASSEMBLY	1
118	PC1	c _v 189 143	MODULE, field current regulator	1
119		c _v 193 453	BRACKET, mtg box fcr	1
120		191 448	TOP, cover front upright	1

Item No.	Dia. Mkgs.	Part No.	Description	Quantity
----------	------------	----------	-------------	----------

Figure 13-1. Main Assembly (Continued)

.. 120	..	◆199 305	.. TOP, cover front upright ss	1
.. 121	..	212 944	.. LABEL, cc stick overlap weld ranges	1
.. 122 Not Applicable	
.. 123	..	+201 750	.. UPRIGHT, front	1
.. 123	..	◆+202 637	.. UPRIGHT, front ss	1
..	..	223 103	.. LABEL, ce sound power level 97db (CC export models only)	1
..	..	173 216	.. LABEL, ce european community mark (CC export models only)	1
.. 124	..	233 953	.. LABEL, warning general precautionary CSA	1
.. 125	..	Figures 13-4, 13-5	.. PANEL, front w/components	1
.. 126	..	CT1 .. ◆202 130	.. XFMR, current sensing	1
.. 127	..	+189 828	.. PANEL, engine side (400P Models)	1
.. 127	..	◆+199 301	.. PANEL, engine side ss	1
.. 128	..	233 088	.. LABEL, danger using a generator indoors can kill you in minutes (unit)	1
..	..	190 058	.. NUT, .250–20 u–nut multi–thread	19
..	..	049 525	.. NUT, 312–18 u–nut multi–thread	32
..	..	215 052	.. KIT, label (includes safety & informational labels) CC models	1
..	..	215 212	.. KIT, label (includes safety & informational labels) CC/CV models	1
..	..	216 989	.. KIT, label (includes safety & informational labels) (CC export models)	1
..	..	216 988	.. KIT, label (includes safety & informational labels) (CC/CV export models)	1

+ When ordering a component originally displaying a precautionary label, the label should also be ordered.

*Recommended Spare Parts.

c_c CC models only.

c_v CC/CV models only.

◆Optional

To maintain the factory original performance of your equipment, use only Manufacturer's Suggested Replacement Parts. Model and serial number required when ordering parts from your local distributor.

Hardware is common and not available unless listed.

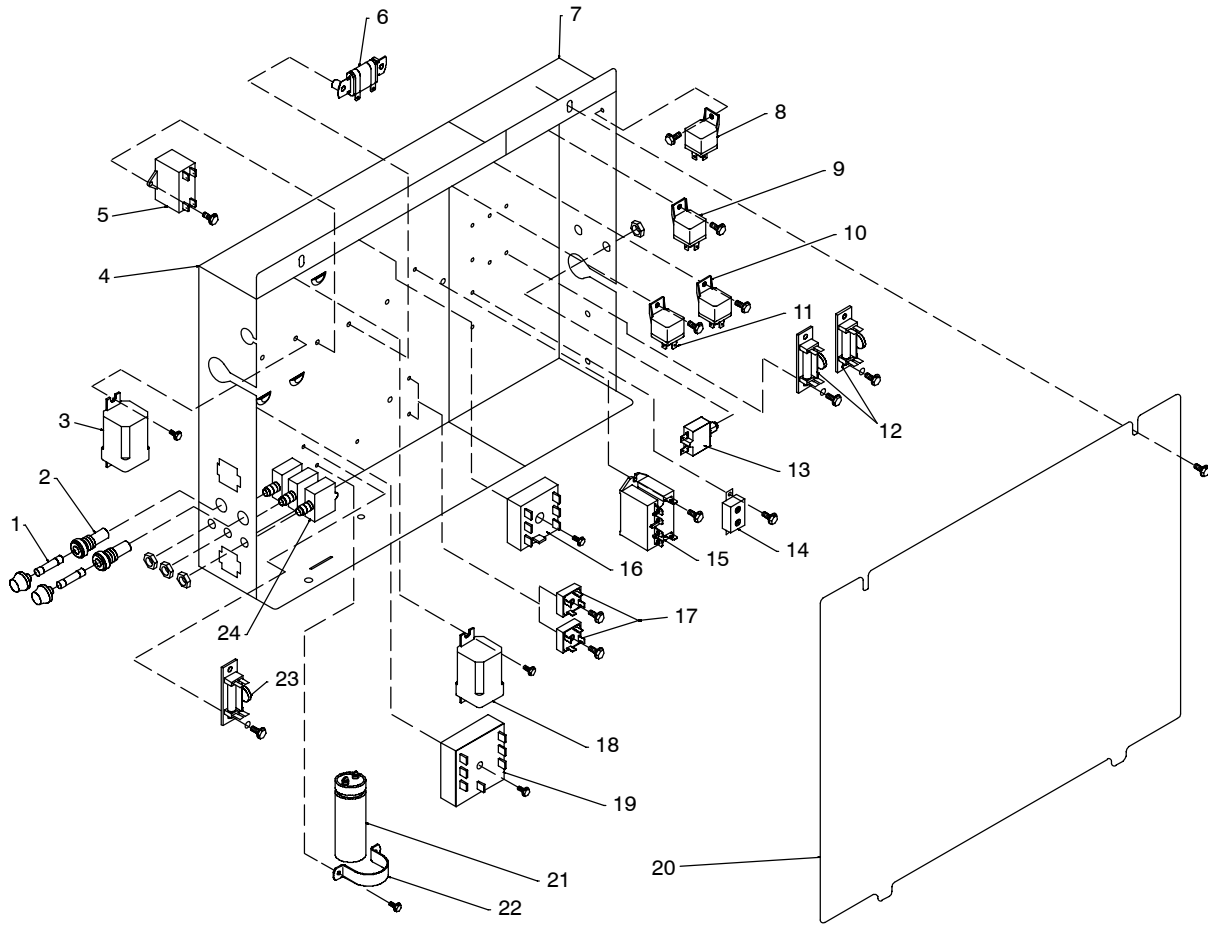

803 647-F

Figure 13-2. Control Box Assembly – CC Models

Item No.	Dia. Mkgs.	Part No.	Description	Quantity
----------	------------	----------	-------------	----------

Figure 13-2. Control Box Assembly – CC Models (Figure 13-1 Item 114)

...	1	F1, F2	*085 874	FUSE, mintr cer slo-blo 10A 250V	2
...	2		046 432	HOLDER, fuse mintr .250 x 1.250	2
...	3	CR7	188 636	RELAY, OCV control	1
...	4		201 077	CONTROL BOX, lh	1
...	5	C12	191 944	CAPACITOR, polyp met film 10. uf 250 vac 10%	1
...	6	R6	141 424	RESISTOR, ww fxd 30 w 25 ohm faston te	1
...	7		201 078	CONTROL BOX, rh	1
...	8	CR3	090 104	RELAY, encl 12VDC SPST 30A/15VDC spin flange mtg	1
...	9	CR8	197 325	RELAY, encl 12vdc spst 70a 4pin flange mtg	1
...	10	CR1	090 104	RELAY, Encl 12vdc Spst 30a/15vdc 5pin Flange Mtg	1
...	11	CR6	◆090104	RELAY, encl 12vdc spst 30a/15vdc 5pin flange mtg	1
...	12	D10/C10, D11/C11	189 701	DIODE/CAPACITOR BOARD	2
...	13	CB14	◆230 635	CIRCUIT BREAKER, auto reset 12vdc 8 amp	1
...	14	CB10	190 374	CIRCUIT BREAKER, auto reset 12VDC 40A	1
...	15	CR5	223 710	RELAY, Encl 12vdc Dpst-no 25a 6pin Flange	1
...	16	PC7	◆195 706	MODULE, pull to idle, two output, 7 pin	1
...	17	SR1, SR2	035 704	RECTIFIER, integ 40A 800V	2
...	18	CR4	◆113 247	RELAY, encl 12vdc dpdt 20a/120vac 8pin flange mtg	1
...	19	TD1	214 928	TIMER, delay on make/break open 30 sec 12vdc	1

Item No.	Dia. Mkgs.	Part No.	Description	Quantity
----------	------------	----------	-------------	----------

Figure 13-2. Control Box Assembly – CC Models Continued

... 20		201 079	.. COVER, control box	1
... 21	C9	087 110	.. CAPACITOR, elctlt 240uf 200VDC	1
... 22		177 136	.. CLAMP, capacitor 1.375dia	1
... 23	D1/C1	189 701	.. DIODE/CAPACITOR BOARD	1
... 24	CB11, 12, 13	139 266	.. SUPPLEMENTARY PROTECTOR, man reset 1p 15a 250vac	3

◆Optional

*Recommended Spare Parts.

To maintain the factory original performance of your equipment, use only Manufacturer's Suggested Replacement Parts. Model and serial number required when ordering parts from your local distributor.

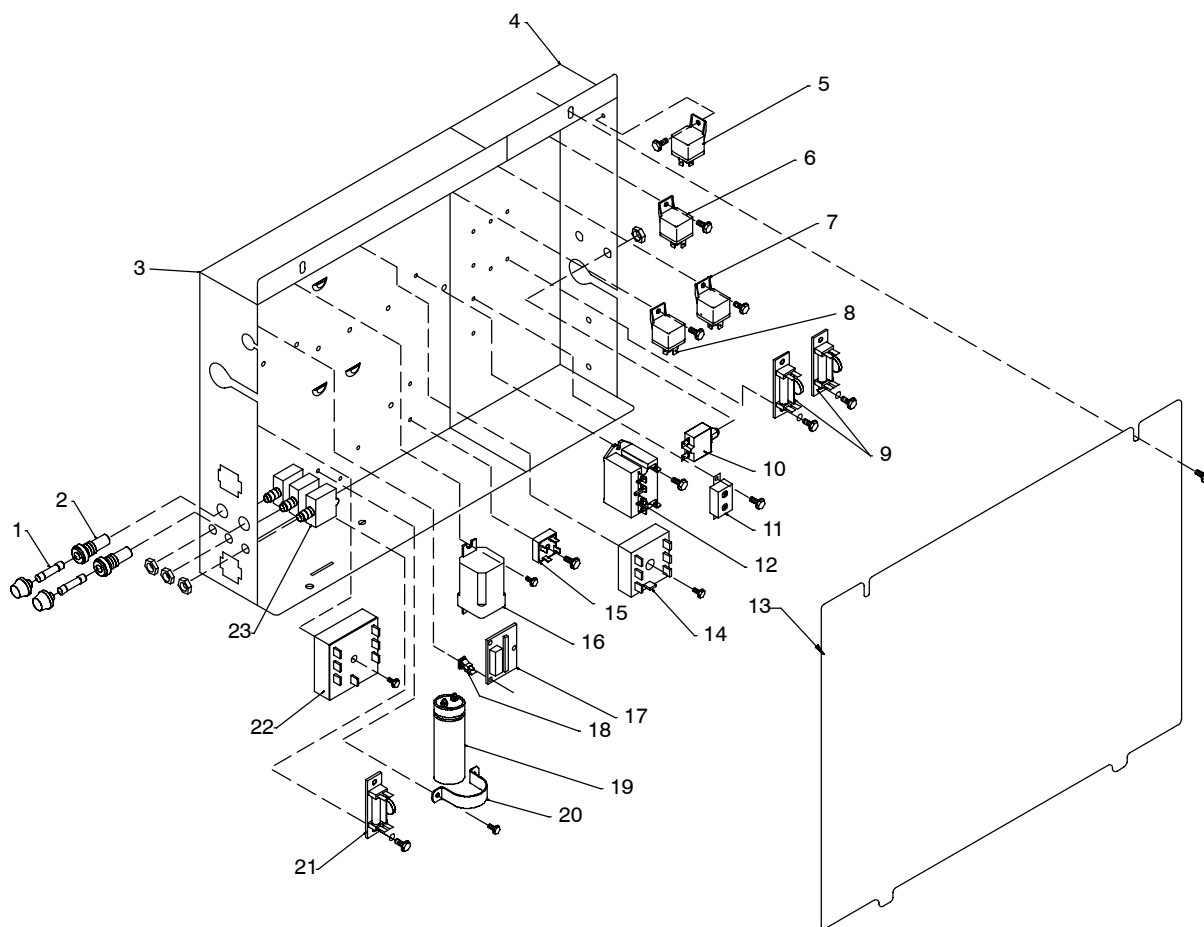

803 648-F

Figure 13-3. Control Box Assembly – CC/CV Models

Item No.	Dia. Mkgs.	Part No.	Description	Quantity
----------	------------	----------	-------------	----------

Figure 13-3. Control Box Assembly – CC/CV Models (Figure 13-1 Item 114)

...	1	...	F1, F2	..	*085 874	..	FUSE, mintr cer slo-blo 10A 250V	2
...	2	046 432	..	HOLDER, fuse mintr .250 x 1.250	2
...	3	201 077	..	CONTROL BOX, lh	1
...	4	201 078	..	CONTROL BOX, rh	1
...	5	CR3	..	◆090 104	..	RELAY, encl 12VDC SPST 30A/15VDC spin flange mtg	1
...	6	CR8	..	197 325	..	RELAY, encl 12vdc spst 70a 4pin flange mtg	1
...	7	CR1	..	090 104	..	RELAY, Encl 12vdc Spst 30a/15vdc 5pin Flange Mtg	1
...	8	CR6	..	◆090 104	..	RELAY, encl 12vdc spst 30a/15vdc 5pin flange mtg	1
...	9	...	D10/C10, D11/C11	..	189 701	..	DIODE/CAPACITOR BOARD	2
...	10	CB14	..	◆230 635	..	CIRCUIT BREAKER, auto reset 12vdc 8 amp	1
...	11	CB10	..	190 374	..	CIRCUIT BREAKER, auto reset 12VDC 40A	1
...	12	CR5	..	223 710	..	RELAY, encl 12VDC dpst-no 25A 6pin flange	1
...	13	201 079	..	COVER, control box	1
...	14	PC7	..	◆195 706	..	MODULE, pull to idle, two output, 7 pin	1
...	15	SR1	..	035 704	..	RECTIFIER, integ 40A 800V	1
...	16	CR4	..	◆113 247	..	RELAY, encl 12vdc dpdt 20a/120vac 8pin flange mtg	1
...	17	PC9	..	192 224	..	CIRCUIT CARD ASSY, display	1
...	18	134 201	..	STAND-OFF, support pc card	3
...	19	C9	..	087 110	..	CAPACITOR, elctlt 240uf 200VDC	1

Item No.	Dia. Mkgs.	Part No.	Description	Quantity
Figure 13-3. Control Box Assembly – CC/CV Models (Continued)				
... 20		177 136	.. CLAMP, capacitor 1.375dia	1
... 21	D1/C1	.. 189 701	.. DIODE/CAPACITOR BOARD	1
... 22	TD1	.. 214 928	.. TIMER, delay on make/break open 30 sec 12vdc	1
... 23	CB11, 12, 13	139 266	.. SUPPLEMENTARY PROTECTOR, man reset 1p 15a 250vac	3

◆Optional

*Recommended Spare Parts.

To maintain the factory original performance of your equipment, use only Manufacturer's Suggested Replacement Parts. Model and serial number required when ordering parts from your local distributor.

 Hardware is common and not available unless listed.

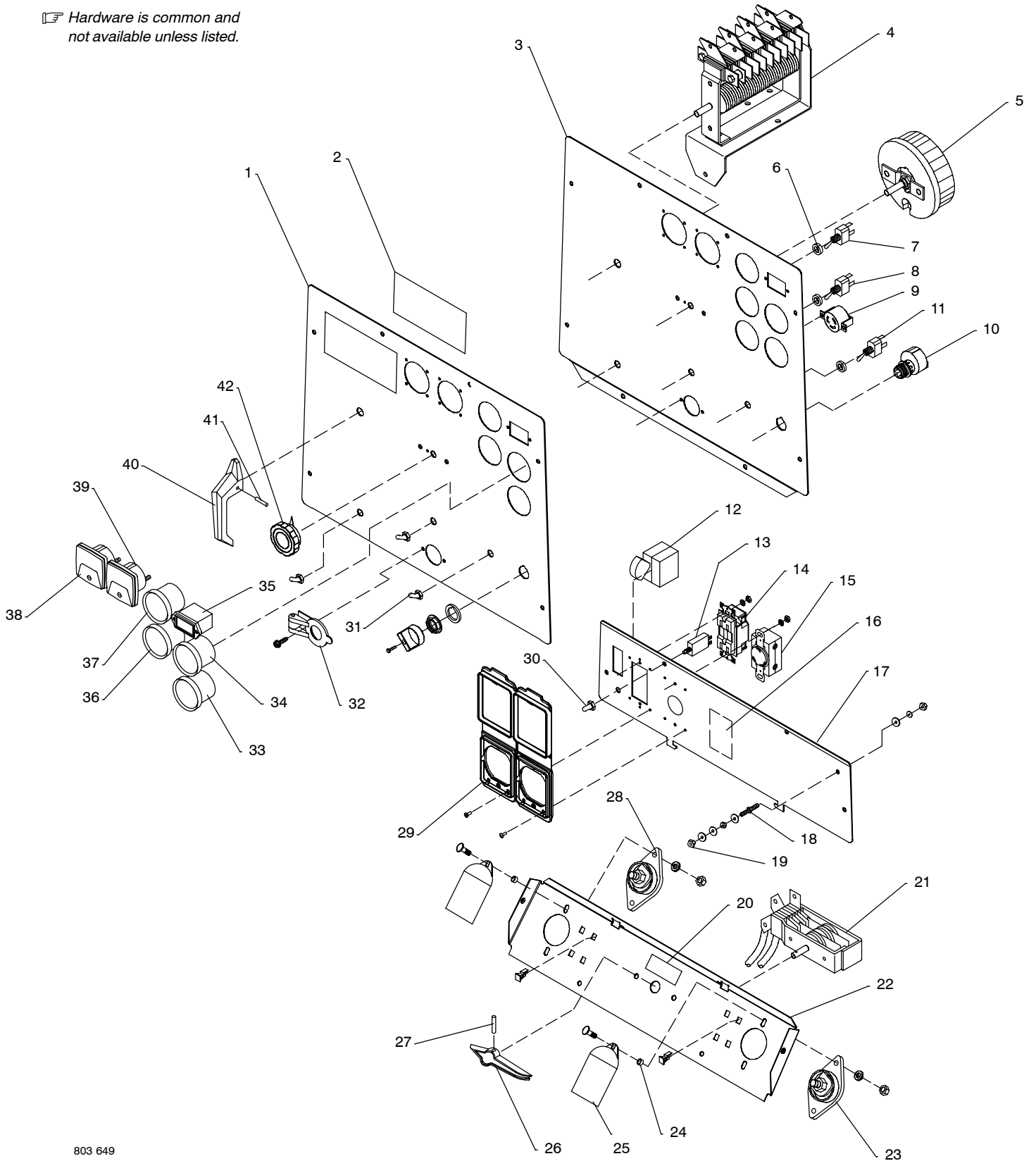

803 649

Figure 13-4. Panel, Front w/Components - CC Models

Item No.	Dia. Mkgs.	Part No.	Description	Quantity
Figure 13-4. Panel, Front w/Components – CC Models (Figure 13-1 Item 125)				
...	1	215 070	PLATE SCREENED, ident control rating; when ordering this item, the nameplate should also be ordered)	1
...	2		NAMEPLATE, screened (order by model and serial number)	1
...	3	215 014	PANEL, engine/weld control	1
...	3	◆220 544	PANEL, engine/weld control ss	1
...	4	S3 208 278	SWITCH, range/changeover	1
...	5	R1 188 635	RHEOSTAT, WW 300W 34 ohm	1
...	6	202 209	SPACER, nylon	3
...	7	S6 011 622	SWITCH, tgl DPDT 15A 125VAC	1
...	8	S5 011 609	SWITCH, tgl SPDT 15A 125VAC on-none-on spd term chr	1
...	9	RC13 032 897	RECEPTACLE, twlk grd 2P3W 15A 125V	1
...	10	S1 212 436	SWITCH, ignition 4 position w/handle	1
...	11	S2 021 467	SWITCH, tgl spst 3a 250v off–none–(on) spd term	1
...		201 553	CLIP, circuit breaker retaining	1
...	12	CB1 201 083	SUPPLEMENTARY PROTECTOR, man reset 2p 20a 250vac	1
...	13	CB2 093 996	SUPPLEMENTARY PRO, man reset 1p 20a 250vac frict	1
...	14	GFCI1 151 981	RECEPTACLE, str dx grd 2P3W 15/20A 125V GFCI	1
...	15	RC1 147 632	RECEPTACLE, tw lk grd 2P3W 30A 250V L6-30R	1
...	15	RC1 176 355	RECEPTACLE, str 2p3w 16a 220v flange mtg (export models only)	1
...		CB3 139 266	SUPPLEMENTARY PROTECTOR, man reset 1p 15a 250vac (export models only)	1
...	16	190 861	LABEL, warning electric shock and moving parts etc	1
...	17	+215 347	PANEL, gen pwr	1
...	17	◆+215 405	PANEL, gen pwr ss	1
...	17	◆+215 403	PANEL, gen pwr (export models only)	1
...	18	083 030	STUD, brs .250–20 x 1.750 w/hex collar	1
...	19	601 836	NUT, 250–20 .50hex .19h brs	3
...	20	◆196 073	LABEL, do not switch while welding	1
...	21	S12 ◆195 825	SWITCH, polarity	1
...	21	S12 ◆220 491	SWITCH, polarity/ac	1
...	22	201 125	PANEL, mtg terminal pwr output	1
...	22	◆199 303	PANEL, mtg terminal pwr output ss	1
...	23	039 046	TERMINAL, pwr output black	1
...		180 735	WASHER, output stud	2
...	24	181 169	SPACER, output stud	2
...	25	186 621	BOOT, generic output stud	2
...	26	◆059 773	HANDLE, switch	1
...	27	◆010 647	PIN, spring cs .156 x 1.250	1
...	28	039 047	TERMINAL, pwr output red	1
...	29	209 056	COVER, receptacle w/gasket	2
...	30	206 795	BOOT, circuit breaker clear hex nut	1
...	31	021 385	BOOT, toggle switch lever	2
...	32	201 045	COVER, receptacle twistlock	1
...	33	◆193 228	METER, Volt Dc 8– 18 Scale 2.250 In Black Face	1
...	34	FUEL 192 265	GAUGE, fuel elec switch w/o sensor	1
...	35	HM 210 424	METER, hour 12-24VDC 2.25dia	1
...	36	217 084	GAUGE, Coolant Temp 0– 300 Deg F Electric	1

Item No.	Dia. Mkgs.	Part No.	Description	Quantity
----------	------------	----------	-------------	----------

Figure 13-4. Panel, Front w/Components – CC Models (Continued)

.....		197 798 ..	SENDER, Coolant Temp 300 Deg F M16 X 1.5	1
... 37		217 083 ..	GAUGE, Pressure Oil 0–100 Psi Electric	1
.....		193 230 ..	SENDER, Pressure Oil 0– 100 Psi	1
... 38		◆164 873 ..	VOLT METER, W/Leads	1
... 39		◆164 874 ..	AMMETER, W/Leads	1
... 40		189 161 ..	HANDLE, switch range	1
... 41		010 647 ..	PIN, spring CS .156 x 1.250	1
... 42		019 602 ..	KNOB, pointer	1
.....		024 103 ..	BLANK, snap-in nyl .750 mtg hole black	1

◆ Optional

+ When ordering a component originally displaying a precautionary label, the label should also be ordered.
To maintain the factory original performance of your equipment, use only Manufacturer's Suggested Replacement Parts. Model and serial number required when ordering parts from your local distributor.

☞ Hardware is common and not available unless listed.

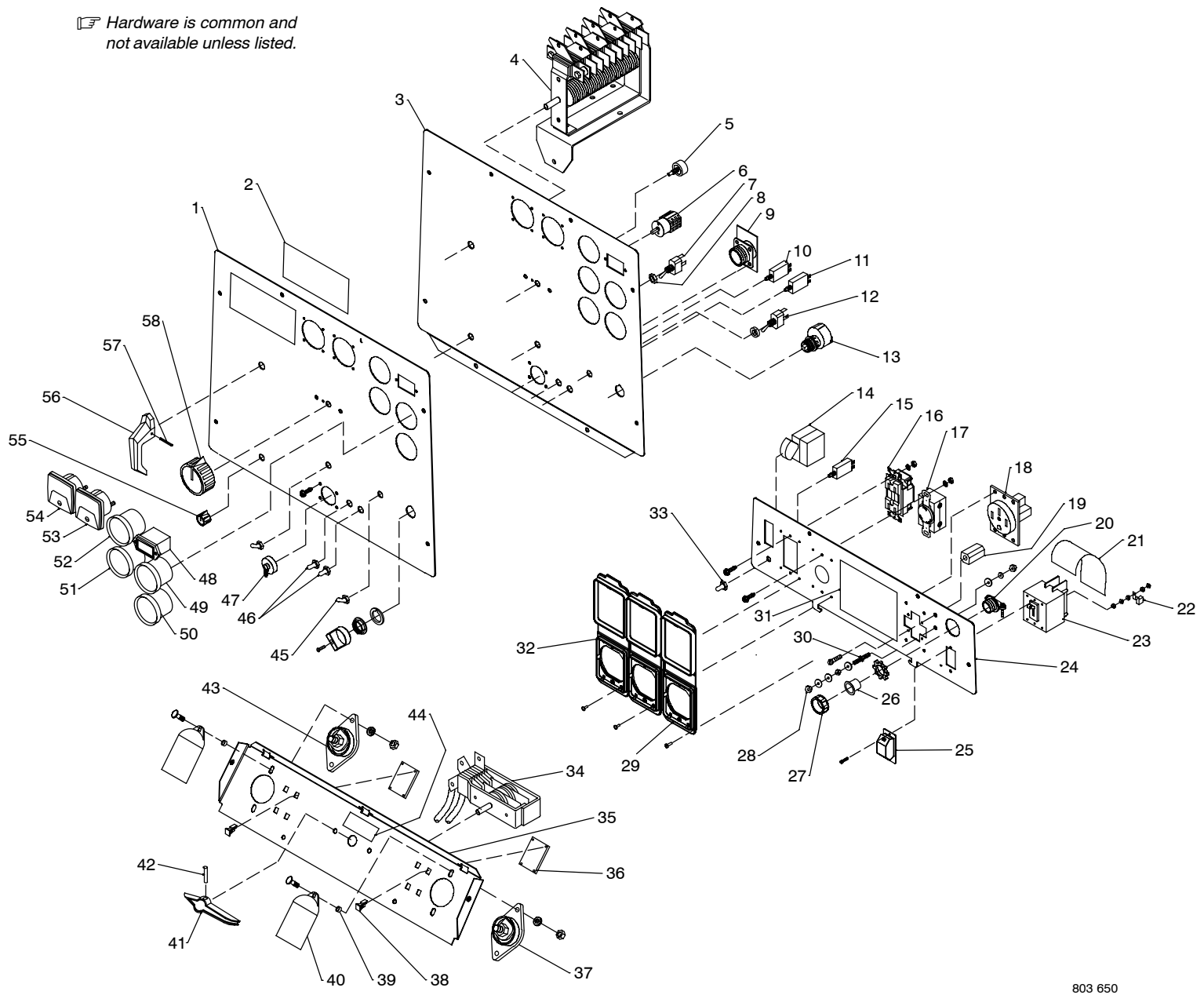

Figure 13-5. Panel, Front w/Components – CC/CV Models

803 650

Item No.	Dia. Mkgs.	Part No.	Description	Quantity
Figure 13-5. Panel, Front w/Components – CC/CV Models (Figure 13-1 Item 125)				
...	1	215 158	PLATE SCREENED, ident control; when ordering this item, the nameplate should also be ordered)	1
...	2		NAMEPLATE, screened (order by model and serial number)	1
...	3	215 014	PANEL, engine/weld control	1
...	3	◆220 544	PANEL, engine/weld control ss	1
...	4	S3 208 278	SWITCH, range/changeover	1
...	5	R1 193 118	POT, cp flat 1t 2w 1k ohm linear	1
...	6	S6 193 234	SWITCH, rotary 6 position gold contacts	1
...		197527	Guard, Circuit Breaker (For S6 - Not Included w/Harness)	1
...	7	S5 011 609	SWITCH, tgl SPDT 15A 125VAC on-none-on spd term chr	1
...	8	202 209	SPACER, nylon	2
...	9	PC6 192 995	CIRCUIT CARD ASSY, connector/receptacle	1
...	10, 11	CB5, CB6 093 995	SUPPLEMENTARY PRO, man reset 1p 15a 250vac frict	2
...	12	S2 021 467	SWITCH, tgl spst 3a 250v off–none–(on) spd term	1
...	13	S1 212 436	SWITCH, ignition 4posn w/o handle	1
...	14	CB1 201 083	SUPPLEMENTARY PROTECTOR, man reset 2p 20a 250vac	1
...		201 553	CLIP, circuit breaker retaining	1
...	15	CB2 093 996	SUPPLEMENTARY PRO, man reset 1p 20a 250vac frict	1
...	16	GFCI1 151 981	RECEPTACLE, str dx grd 2P3W 15/20A 125V GFCI	1
...	17	RC1 147 632	RECEPTACLE, tw lk grd 2P3W 30A 250V L6-30R	1
...	17	RC1 176 355	RECEPTACLE, str 2p3w 16a 220v flange mtg (export models only)	1
...		CB3 139 266	SUPPLEMENTARY PROTECTOR, man reset 1p 15a 250vac (export models only)	1
...	18	RC5 ◆182 954	RCPT, str 3P4W 50A 125/250V	1
...	19	◆025 248	STAND-OFF, insul .250-20 x 1.2	1
...	20	◆604 102	CONNECTOR, clamp cable 1.000	1
...	21	◆197 527	GUARD, circuit breaker	1
...	22	◆197 363	TERMINAL, ring tng screw clamp	3
...	23	CB7 ◆214 926	SUPPLEMENTARY PROTECTOR, man reset 3p 50a 250vac	1
...	24	+215 347	PANEL, generator power	1
...	24	+215 403	PANEL, gen pwr (export models only)	1
...	24	◆215 406	PANEL, generator power ss	1
...	24	+◆215 363	PANEL, generator power (full kVA option)	1
...	25	◆214 927	BOOT, circuit breaker 1 pole	1
...	26	◆197 508	PLUG, protective	1
...	27	◆077 440	BUSHING, conduit 1 in	1
...	28	601 836	NUT, 250–20 .50hex .19h brs	3
...	29	209 056	COVER, receptacle w/gasket	1
...	30	083 030	STUD, brs .250–20 x 1.750 w/hex collar	1
...		CT2 ◆197 433	TRANSFORMER, current sensing	1
...	31	190 861	LABEL, warning electric shock and moving parts etc	1
...	31	◆197 399	LABEL, warning 3 ph generator power	1
...	32	209 056	COVER, receptacle w/gasket	2
...	33	206 795	BOOT, circuit breaker clear hex nut	1
...	34	S12 ◆195 825	SWITCH, polarity	1
...		S12 ◆220 491	SWITCH, polarity/AC	1
...	35	201 125	PANEL, mtg terminal pwr output	1
...	35	199 303	PANEL, mtg terminal pwr output ss	1
...	36	PC4, PC5 189 744	CIRCUIT CARD ASSEMBLY, filter hf	2
...	37	039 046	TERMINAL, pwr output black	1
...		180 735	WASHER, output stud	2

Item No.	Dia. Mkgs.	Part No.	Description	Quantity
----------	------------	----------	-------------	----------

Figure 13-5. Panel, Front w/Components – CC/CV Models (Continued)

... 38		134 201	.. STAND-OFF, support	12
... 39		181 169	.. SPACER, output stud	2
... 40		186 621	.. BOOT, generic output stud	2
... 41		◆059 773	.. HANDLE, switch	1
... 42		◆010 647	.. PIN, spring cs .156 x 1.250	1
... 43		039 047	.. TERMINAL, pwr output red	1
... 44		◆196 073	.. LABEL, do not switch while welding	1
... 45		021 385	.. BOOT, toggle switch lever	1
... 46		190 323	.. BOOT, circuit breaker clear hex nut	2
... 47		170 391	.. CONN, circ ms protective cap size 20	1
... 48	HM	210 424	.. METER, hour 12–24vdc (snap-in)	1
... 49	FUEL	192 265	.. GAUGE, fuel elec switch w/o sensor	1
... 50		◆193 228	.. METER, Volt Dc 8– 18 Scale 2.250 In Black Face	1
... 51		◆217 084	.. GAUGE, Coolant Temp 0– 300 Deg F Electric	1
		197 798	.. SENDER, Coolant Temp 300 Deg F M16 X 1.5	1
... 52		217 083	.. GAUGE, Pressure Oil 0–100 Psi Electric	1
		193 230	.. SENDER, Pressure Oil 0– 100 Psi	1
... 53		◆164 873	.. METER, amp ac/dc 0– 500 0–600 dc scale 2.5 in	1
... 54		◆164 874	.. METER, volt ac/dc 0– 100 scale 2.5 in	1
... 55		097 922	.. KNOB, pointer .875 dia x .250 ID w/set screws plstc	1
... 56		189 161	.. HANDLE, switch range	1
... 57		010 647	.. PIN, spring CS .156 x 1.250	1
... 58		097 924	.. KNOB, pointer 1.625 dia x .250 ID w/set scrws plstc	1
		024 103	.. BLANK, snap-in nyl .750 mtg hole blk	1
		120 304	.. BLANK, snap-in nyl .250 mtg hole black	2

◆Optional

+ When ordering a component originally displaying a precautionary label, the label should also be ordered.

To maintain the factory original performance of your equipment, use only Manufacturer's Suggested Replacement Parts. Model and serial number required when ordering parts from your local distributor.

☞ Hardware is common and not available unless listed.

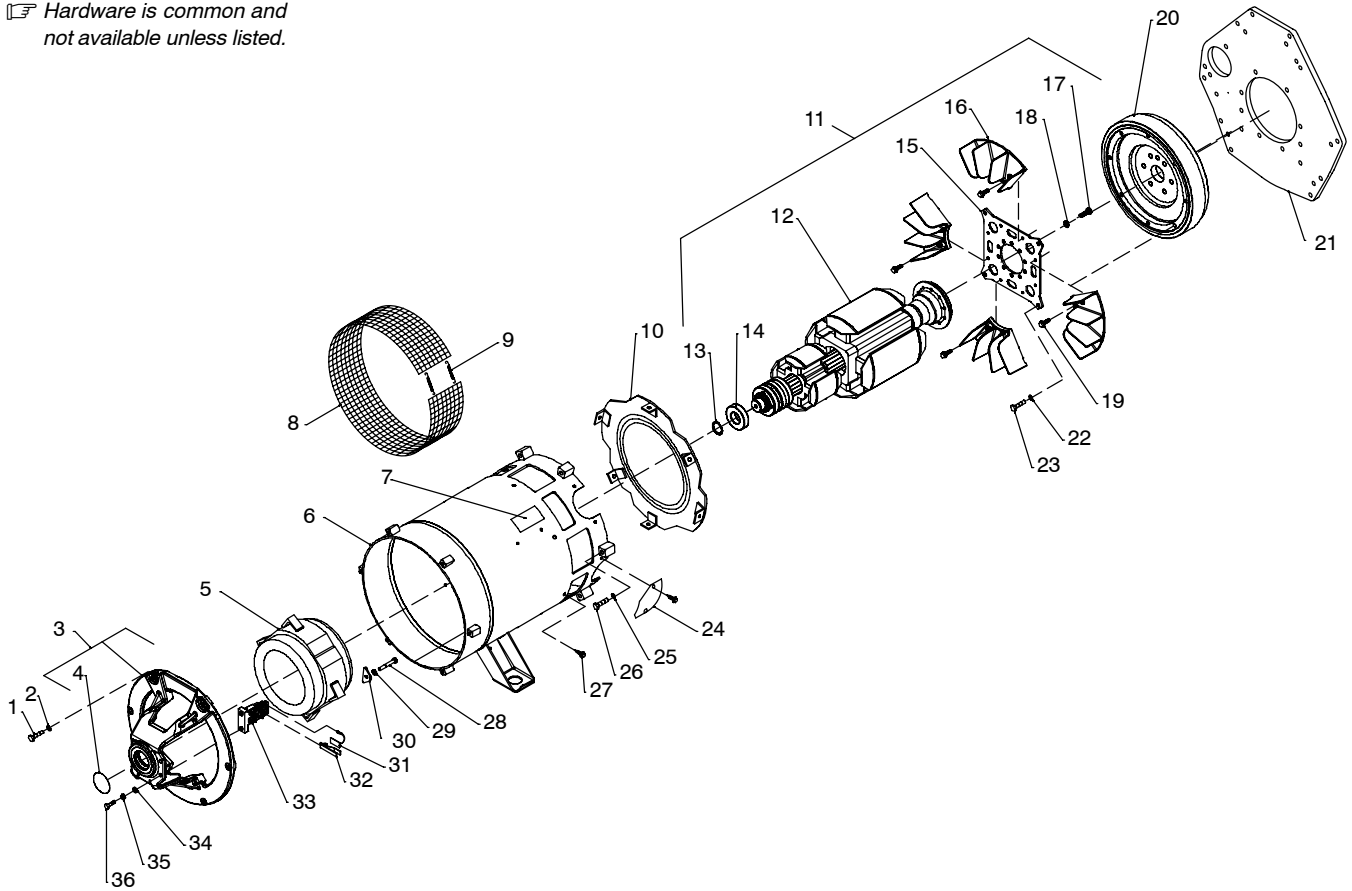

802 552-B

Figure 13-6. Generator

Item No.	Dia. Mkgs.	Part No.	Description	Quantity
----------	------------	----------	-------------	----------

Figure 13-6. Generator (Figure 13-1 Item 93)

...	1	132 053	.. SCREW, .375-16x1.50 hex hd-pln gr5 pld	6
...	2	183 387	.. WASHER, conical spring .406 ID x .875 OD pltd	6
...	3	195 911	.. ENDBELL, gen (consisting of)	1
...	4	143 220	.. O-RING, 2.859 ID x .139CS	1
...	5	201 099	.. STATOR, exciter/gen pwr	1
...	6	+215 011	.. STATOR, weld assembly complete	1
...	6	+♦216 318	.. STATOR, weld assembly complete (full kVA option)	1
...	7	225 120	.. LABEL, warning moving parts can cause injury	2
...	8	190 197	.. GUARD, generator wire mesh	1
...	9	172 674	.. SPRING, ext .240 OD x .041 wire x 3.500pld	2
...	10	039 207	.. BAFFLE, air	1
...	11	ROTOR.. 212 996	.. ROTOR, Generator Segmented Assy (Includes)	1
...	12	210 824	.. ROTOR, Generator (Includes)	1
...	13	024 617	.. RING, Rtnng Ext 1.375 Shaft X .050 Thk	1
...	14	053 390	.. BEARING, Ball Rdl Sgl Row 1.370 X 2.830 X .6	1
...			.. HUB, Drive (Not Sold Separately)	1
...		210 447	.. FAN, Rotor Assy Generator (Segmented) (includes)	1
...	15	210 332	.. PLATE, Flex Hubmount	1
...	16	206 242	.. FAN, Rotor Segmented Assy Gen	4
...	17	049 026	.. SCREW, M10-1.5x 25 Hex Hd-pln 8.8 Pln	10
...	18	083 883	.. WASHER, Lock .402idx.0.709odx.0.087t Stl Split10mm	10
...	19	080 389	.. SCREW, 312-18x1.00 Hexwhd.66d Stl Pld Slffmg Tap-rw	8
...	20	197 487	.. FLYWHEEL	1

Item No.	Dia. Mkgs.	Part No.	Description	Quantity
Figure 13-6. Generator (Continued)				
... 21		197 486	.. ADAPTER, Engine	1
... 22		083 883	.. WASHER, Lock .402idx0.709odx.087t Stl Split10mm	4
... 23		049 026	.. SCREW, M10-1.5x 25 Hex Hd-pln 8.8 Pln	4
... 24		191 579	.. COVER, starter hole /Continental	1
		195 560	.. GUARD, starter hole deutz 912	1
... 25		083 883	.. WASHER, Lock .402idx0.709odx.087t Stl Split10mm	6
... 26		172 555	.. SCREW, M10-1.5 x 50hexhd pln 8.8pld	6
... 27		602 159	.. SCREW, .312-18x .75 hexwhd.66d stl pld slffmg tap-rw	6
... 28		601 961	.. SCREW, .312-18 x 2.25hexhd pln gr 5pld	4
... 29		602 211	.. WASHER, lock .318 ID x 0.586	6
... 30		139 341	.. WASHER, exciter	4
... 31		*190 823	.. BRUSH, contact	3
... 32		208 469	.. CLIP, spring	3
... 33		189 142	.. BRUSHHOLDER ASSEMBLY, gen	1
... 34		602 242	.. WASHER, flat .375IDx0.875odx.083t stl pld	2
... 35		602 211	.. WASHER, Lock .318idx0.586odx.078t Stl Pld Split.312	2
... 36		604 534	.. SCREW, .312-18x1.25 hex hd-pln gr5 pld	2

+ When ordering a component originally displaying a precautionary label, the label should also be ordered.

*Recommended Spare Parts.

◆Optional

To maintain the factory original performance of your equipment, use only Manufacturer's Suggested Replacement Parts. Model and serial number required when ordering parts from your local distributor.

☞ Hardware is common and not available unless listed.

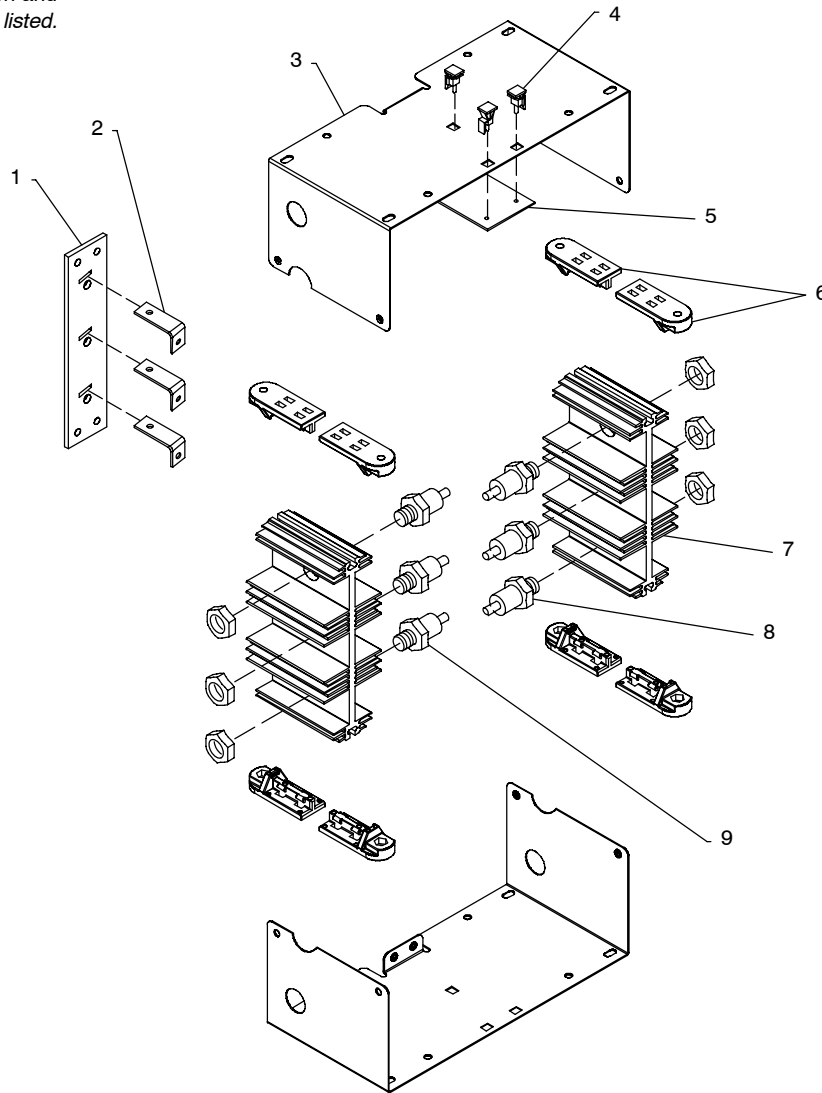

802 279-A

Figure 13-7. Main Rectifier Assembly

Item No.	Dia. Mkgs.	Part No.	Description	Quantity
----------	------------	----------	-------------	----------

Figure 13-7. Main Rectifier Assembly (Figure 13-1 Item 117)

.....	SR3	...	215 910	.. RECTIFIER, environment (consisting of)	1
... 1	188 137 CONNECTION BOARD, rectifier AC	1
... 2	188 517 BUS BAR, connection board	3
... 3	188 135 ENCLOSURE, rectifier	2
... 4	134 201 STAND-OFF, support	3
... 5	PC3	...	215 755 CIRCUIT CARD ASSEMBLY, protection	1
... 6	188 136 INSULATOR, heat sink	8
... 7	188 493 HEAT SINK, rectifier al	2
... 8	D3, D5, D7	...	208 334 DIODE, rect 275A 300V SP	3
... 9	D2, D4, D6	...	208 335 DIODE, rect 275A 300V RP	3

To maintain the factory original performance of your equipment, use only Manufacturer's Suggested Replacement Parts. Model and serial number required when ordering parts from your local distributor.

☞ Some wiring harness components (switches, relays, circuit breakers) are also referenced elsewhere in this parts list. Purchase components separately or as part of the associated wiring harness.

Item No.	Dia. Mkgs.	Part No.	Description	Quantity
Wiring Harnesses				
		215054	Harness, control box, CC weld control (includes)	1
	SR1, SR2	035704	Rectifier, Integ Bridge 40. Amp 800v	2
	D1/C1	189701	Diode/Capacitor Board,	1
	RC4	047483	Conn, Rect Univ 084 15p/S 3row Rcpt Cable/Panel Lkg	1
CB11, CB12, CB13		139266	Supplementary Protector, Man Reset 1p 15a 250vac	3
	CR7	188636	Relay, Ocv Control	1
		148850	Socket, Relay 5 Pin	1
	S6	011622	Switch, Tgl 3pdt 15a 125vac On–none–on Spd Term	1
	S5	011609	Switch, Tgl Spdt 15a 125vac On–none–on Spd Term Chr	1
		211292	Conn, Pack 4p 1row Female	1
		211293	Conn, Pack Terminal Position Assurance(Lock)	1
		164617	Clip, Wiring Straight	3
	S2	021467	Switch, Tgl Spst 3a 250v Off–none–(On) Spd Term	1
		150316	Conn, Rect Univ 039 6p/S 3row Plug Cable Lkg	5
	RC3	158466	Conn, Rect Univ 084 12p/S 3row Rcpt Cable/Panel Lkg	1
	RC1	135133	Conn, Rect Univ 084 9p/S 3row Rcpt Cable/Panel Lkg	1
		215377	Harness, control box, CV weld control (includes)	1
CB11, CB12, CB13		139266	Supplementary Protector, Man Reset 1p 15a 250vac	3
	SR1	035704	Rectifier, Integ Bridge 40. Amp 800v	1
		148850	Socket, Relay 5 Pin	1
	RC4	047483	Conn, Rect Univ 084 15p/S 3row Rcpt Cable/Panel Lkg	1
	RC3	158466	Conn, Rect Univ 084 12p/S 3row Rcpt Cable/Panel Lkg	1
	RC1	135133	Conn, Rect Univ 084 9p/S 3row Rcpt Cable/Panel Lkg	1
		150316	Conn, Rect Univ 039 6p/S 3row Plug Cable Lkg	6
	S6	193234	Switch, Rotary 6 Posn Gold Contacts	1
		021467	Switch, Tgl Spst 3a 250v Off–none–(On) Spd Term	1
	S5	011609	Switch, Tgl Spdt 15a 125vac On–none–on Spd Term Chr	1
	D1/C1	189701	Diode/Capacitor Board,	1
		193183	Conn, Rect Cinch 18 Pin	1
		196602	Plug, Cavity 18,30 Position Cinch Connector	4
		196603	Seal, Switch 6 Position Rotary .250 Shaft	1
		141450	Conn, Rect Metrmate 10skt 1row Plug Cable Lkg	1
CB5, CB6		093995	Supplementary Pro, Man Reset 1p 15a 250vac Frict	2
		211292	Conn, Pack 4p 1row Female	1
		211293	Conn, Pack Terminal Position Assurance(Lock)	1
		215013	Harness, weld control CC (includes)	1
	PLG3	158465	Conn, Rect Univ 084 12p/S 3row Plug Cable Lkg	1
		187654	Seal, Wire Univ 12p/S 3row	1
	PLG6	114063	Conn, Rect Univ 084 4p/S 1row Plug Cable Lkg	1
		215207	Harness, weld control CV (includes)	1
	PLG6	114063	Conn, Rect Univ 084 4p/S 1row Plug Cable Lkg	1
	PLG8	193184	Conn, Rect Cinch 30 Pin	1
	PLG13	147992	Conn, Rect Univ 039 10p/S 2row Plug Cable Lkg	1
	PLG3	158465	Conn, Rect Univ 084 12p/S 3row Plug Cable Lkg	1
		187654	Seal, Wire Univ 12p/S 3row	1
		196602	Plug, Cavity 18,30 Position Cinch Connector	6

Item No.	Dia. Mkgs.	Part No.	Description	Quantity
Wiring Harnesses (Continued)				
.....		221376	Harness, engine control (includes)	1
D10/C10, D11/C11	...	189701	Diode/Capacitor Board,	2
.....	CB10	190374	Circuit Breaker, Auto Reset 12vdc 40 Amp	1
.....	CR1	090104	Relay, Encl 12vdc Spst 30a/15vdc 5pin Flange Mtg	1
.....		148850	Socket, Relay 5 Pin	1
.....	PLG4	114062	Conn, Rect Univ 084 15p/S 3row Plug Cable Lkg	1
.....		212116	Conn, Deutsch 2p 1row Female Plug	3
.....		212117	Conn, Deutsch Wedge Lock 2 Position	3
.....	CR8	197325	Relay, Encl 12vdc Spst 70a 4pin Flange Mtg	1
.....		192558	Harness, range switch (includes)	1
.....	RC6	148389	Conn,Rect Univ 084 4p/S 1row Rcpt Cable/Panel Lkg	1
.....		201109	Harness, receptacle auxiliary power (includes)	1
.....	RC1	147632	Rcpt, Tw Lk Grd 2p3w 30a 250v *L6-30r	1
.....	GFCI1	151981	Rcpt, Str Dx Grd 2p3w 15/20a 125v *5-20r Gfi	1
.....	CB2	093996	Supplementary Pro, Man Reset 1p 20a 250vac Frict	1
.....		201053	Harness, receptacle auxiliary power (export models) (includes) ...	1
.....	GFCI1	151981	Rcpt, Str Dx Grd 2p3w 15/20a 125v *5-20r Gfi	1
.....	CB3	139266	Supplementary Protector, Man Reset 1p 15a 250vac	1
.....	CB2	093996	Supplementary Pro, Man Reset 1p 20a 250vac Frict	1
.....		190259	Harness, brushholder (includes)	1
.....	PLG1	135134	Conn, Rect Univ 084 9p/S 3row Plug Cable Lkg	1
.....		187651	Seal, Wire Univ 9p/S 3row	1

TRUE BLUE[®]

WARRANTY

Effective January 1, 2007

(Equipment with a serial number preface of "LH" or newer)

This limited warranty supersedes all previous Miller warranties and is exclusive with no other guarantees or warranties expressed or implied.

Warranty Questions?

Call
1-800-4-A-MILLER
for your local
Miller distributor.

Your distributor also gives
you ...

Service

You always get the fast,
reliable response you
need. Most replacement
parts can be in your
hands in 24 hours.

Support

Need fast answers to the
tough welding questions?
Contact your distributor.
The expertise of the
distributor and Miller is
there to help you, every
step of the way.

LIMITED WARRANTY – Subject to the terms and conditions below, Miller Electric Mfg. Co., Appleton, Wisconsin, warrants to its original retail purchaser that new Miller equipment sold after the effective date of this limited warranty is free of defects in material and workmanship at the time it is shipped by Miller. THIS WARRANTY IS EXPRESSLY IN LIEU OF ALL OTHER WARRANTIES, EXPRESS OR IMPLIED, INCLUDING THE WARRANTIES OF MERCHANTABILITY AND FITNESS.

Within the warranty periods listed below, Miller will repair or replace any warranted parts or components that fail due to such defects in material or workmanship. Miller must be notified in writing within thirty (30) days of such defect or failure, at which time Miller will provide instructions on the warranty claim procedures to be followed.

Miller shall honor warranty claims on warranted equipment listed below in the event of such a failure within the warranty time periods. All warranty time periods start on the delivery date of the equipment to the original end-user purchaser, and not to exceed one year after the equipment is shipped to a North American distributor or eighteen months after the equipment is shipped to an International distributor.

1. 5 Years Parts — 3 Years Labor
 - * Original main power rectifiers
2. 3 Years — Parts and Labor
 - * Transformer/Rectifier Power Sources
 - * Plasma Arc Cutting Power Sources
 - * Process Controllers
 - * Semi-Automatic and Automatic Wire Feeders
 - * Inverter Power Sources (Unless Otherwise Stated)
 - * Water Coolant Systems (Integrated)
 - * Intellitig
 - * Engine Driven Welding Generators
(NOTE: Engines are warranted separately by the engine manufacturer.)
3. 1 Year — Parts and Labor Unless Specified
 - * Motor Driven Guns (w/exception of Spoolmate Spoolguns)
 - * Positioners and Controllers
 - * Automatic Motion Devices
 - * RFCS Foot Controls
 - * Induction Heating Power Sources, Coolers, and Electronic Controls/Recorders
 - * Water Coolant Systems (Non-Integrated)
 - * Flowgauge and Flowmeter Regulators (No Labor)
 - * HF Units
 - * Grids
 - * Spot Welders
 - * Load Banks
 - * Arc Stud Power Sources & Arc Stud Guns
 - * Racks
 - * Running Gear/Trailers
 - * Plasma Cutting Torches (except APT & SAF Models)
 - * Field Options
(NOTE: Field options are covered under True Blue[®] for the remaining warranty period of the product they are installed in, or for a minimum of one year — whichever is greater.)
 - * Bernard-Branded Mig Guns (No Labor)
 - * Weldcraft-Branded TIG Torches (No Labor)
 - * Subarc Wire Drive Assemblies
4. 6 Months — Batteries
5. 90 Days — Parts
 - * MIG Guns/TIG Torches and Subarc (SAW) Guns

- * Induction Heating Coils and Blankets, Cables, and Non-Electronic Controls
- * APT & SAF Model Plasma Cutting Torches
- * Remote Controls
- * Accessory (Kits)
- * Replacement Parts (No labor)
- * Spoolmate Spoolguns
- * Canvas Covers

Miller's True Blue[®] Limited Warranty shall not apply to:

1. **Consumable components; such as contact tips, cutting nozzles, contactors, brushes, slip rings, relays or parts that fail due to normal wear. (Exception: brushes, slip rings, and relays are covered on Bobcat, Trailblazer, and Legend models.)**
2. Items furnished by Miller, but manufactured by others, such as engines or trade accessories. These items are covered by the manufacturer's warranty, if any.
3. Equipment that has been modified by any party other than Miller, or equipment that has been improperly installed, improperly operated or misused based upon industry standards, or equipment which has not had reasonable and necessary maintenance, or equipment which has been used for operation outside of the specifications for the equipment.

MILLER PRODUCTS ARE INTENDED FOR PURCHASE AND USE BY COMMERCIAL/INDUSTRIAL USERS AND PERSONS TRAINED AND EXPERIENCED IN THE USE AND MAINTENANCE OF WELDING EQUIPMENT.

In the event of a warranty claim covered by this warranty, the exclusive remedies shall be, at Miller's option: (1) repair; or (2) replacement; or, where authorized in writing by Miller in appropriate cases, (3) the reasonable cost of repair or replacement at an authorized Miller service station; or (4) payment of or credit for the purchase price (less reasonable depreciation based upon actual use) upon return of the goods at customer's risk and expense. Miller's option of repair or replacement will be F.O.B., Factory at Appleton, Wisconsin, or F.O.B. at a Miller authorized service facility as determined by Miller. Therefore no compensation or reimbursement for transportation costs of any kind will be allowed.

TO THE EXTENT PERMITTED BY LAW, THE REMEDIES PROVIDED HEREIN ARE THE SOLE AND EXCLUSIVE REMEDIES. IN NO EVENT SHALL MILLER BE LIABLE FOR DIRECT, INDIRECT, SPECIAL, INCIDENTAL OR CONSEQUENTIAL DAMAGES (INCLUDING LOSS OF PROFIT), WHETHER BASED ON CONTRACT, TORT OR ANY OTHER LEGAL THEORY.

ANY EXPRESS WARRANTY NOT PROVIDED HEREIN AND ANY IMPLIED WARRANTY, GUARANTY OR REPRESENTATION AS TO PERFORMANCE, AND ANY REMEDY FOR BREACH OF CONTRACT TORT OR ANY OTHER LEGAL THEORY WHICH, BUT FOR THIS PROVISION, MIGHT ARISE BY IMPLICATION, OPERATION OF LAW, CUSTOM OF TRADE OR COURSE OF DEALING, INCLUDING ANY IMPLIED WARRANTY OF MERCHANTABILITY OR FITNESS FOR PARTICULAR PURPOSE, WITH RESPECT TO ANY AND ALL EQUIPMENT FURNISHED BY MILLER IS EXCLUDED AND DISCLAIMED BY MILLER.

Some states in the U.S.A. do not allow limitations of how long an implied warranty lasts, or the exclusion of incidental, indirect, special or consequential damages, so the above limitation or exclusion may not apply to you. This warranty provides specific legal rights, and other rights may be available, but may vary from state to state.

In Canada, legislation in some provinces provides for certain additional warranties or remedies other than as stated herein, and to the extent that they may not be waived, the limitations and exclusions set out above may not apply. This Limited Warranty provides specific legal rights, and other rights may be available, but may vary from province to province.

miller_warr 2007-01





Owner's Record

Please complete and retain with your personal records.

Model Name

Serial/Style Number

Purchase Date

(Date which equipment was delivered to original customer.)

Distributor

Address

City

State

Zip



For Service

Contact a DISTRIBUTOR or SERVICE AGENCY near you.

Always provide Model Name and Serial/Style Number.

Contact your Distributor for:

Welding Supplies and Consumables

Options and Accessories

Personal Safety Equipment

Service and Repair

Replacement Parts

Training (Schools, Videos, Books)

Technical Manuals (Servicing Information and Parts)

Circuit Diagrams

Welding Process Handbooks

To locate a Distributor or Service Agency visit www.millerwelds.com or call 1-800-4-A-Miller

Contact the Delivering Carrier to:

File a claim for loss or damage during shipment.

For assistance in filing or settling claims, contact your distributor and/or equipment manufacturer's Transportation Department.

Miller Electric Mfg. Co.

An Illinois Tool Works Company
1635 West Spencer Street
Appleton, WI 54914 USA

International Headquarters—USA

USA Phone: 920-735-4505 Auto-Attended
USA & Canada FAX: 920-735-4134
International FAX: 920-735-4125

European Headquarters – United Kingdom

Phone: 44 (0) 1204-593493
FAX: 44 (0) 1204-598066

www.MillerWelds.com



Free Manuals Download Website

<http://myh66.com>

<http://usermanuals.us>

<http://www.somanuals.com>

<http://www.4manuals.cc>

<http://www.manual-lib.com>

<http://www.404manual.com>

<http://www.luxmanual.com>

<http://aubethermostatmanual.com>

Golf course search by state

<http://golfingnear.com>

Email search by domain

<http://emailbydomain.com>

Auto manuals search

<http://auto.somanuals.com>

TV manuals search

<http://tv.somanuals.com>