

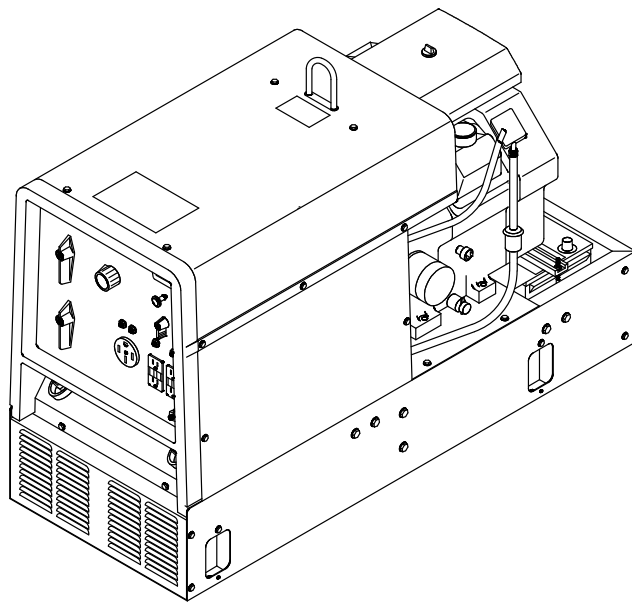

**Miller**<sup>®</sup>

January 1997      Form: OM-175 104B  
Effective With Serial No. KG191348

# OWNER'S MANUAL



## Bobcat™ 225G <sup>plus</sup> (Kohler-Powered)

CC/CV AC/DC Welding Generator For SMAW, FCAW, GMAW, GTAW Welding

Welding Mode	Weld Output Range	Rated Welding Output	Maximum Open-Circuit Voltage	Auxiliary Power Rating	Fuel Capacity	Engine
CC/AC	50 – 225 A	225 A, 25 V, 100% Duty Cycle	80	Single-Phase, 8 kVA/kW, 70/35 A, 120/240 V AC, 60 Hz	8.5 gal (32 L) Tank	Kohler CH18 Air-Cooled, Two-Cylinder, Four-Cycle, 18 HP Gasoline Engine
CC/DC	50 – 210 A	210 A, 25 V, 100% Duty Cycle	72			
CV/DC	17 – 28 V	200 A, 20 V, 100% Duty Cycle	33			

# TABLE OF CONTENTS







---

<b>SECTION 1 – SAFETY PRECAUTIONS FOR ARC WELDING</b> .....	1
1-1. Symbol Usage .....	1
1-2. Arc Welding Hazards .....	1
1-3. Engine Hazards .....	2
1-4. Additional Installation, Operation, And Maintenance Hazards .....	3
1-5. Principal Safety Standards .....	3
1-6. EMF Information .....	3
<b>SECTION 2 – DEFINITIONS</b> .....	4
2-1. Symbol Definitions .....	4
<b>SECTION 3 – INSTALLATION</b> .....	5
3-1. Installing Welding Generator .....	5
3-2. Dimensions, Weights, And Operating Angles .....	5
3-3. Fuel Consumption .....	6
3-4. Engine Prestart Checks .....	6
3-5. Connecting The Battery .....	7
3-6. Weld Output Terminals And Selecting Cable Sizes .....	7
<b>SECTION 4 – OPERATING WELDING GENERATOR</b> .....	8
4-1. Front Panel Controls .....	8
4-2. Duty Cycle .....	9
<b>SECTION 5 – OPERATING AUXILIARY EQUIPMENT</b> .....	10
5-1. Standard Receptacles .....	10
5-2. Optional Auxiliary Power Receptacles .....	11
5-3. Wiring Optional 240 Volt Plug .....	12
<b>SECTION 6 – MAINTENANCE AND TROUBLESHOOTING</b> .....	13
6-1. Routine Maintenance .....	13
6-2. Maintenance Label .....	14
6-3. Servicing Air Cleaner .....	14
6-4. Changing Engine Oil, Oil Filter, And Fuel Filter .....	15
6-5. Adjusting Engine Speed .....	16
6-6. Overload Protection .....	17
6-7. Inspecting And Cleaning Optional Spark Arrestor .....	17
6-8. Troubleshooting .....	18
<b>SECTION 7 – ELECTRICAL DIAGRAM</b> .....	20
<b>SECTION 8 – PARTS LIST</b> .....	21

# SECTION 1 – SAFETY PRECAUTIONS FOR ARC WELDING

safety\_rom1 4/95

## 1-1. Symbol Usage

	Means Warning! Watch Out! There are possible hazards with this procedure! The possible hazards are shown in the adjoining symbols.		Marks a special safety message.	
				This group of symbols means Warning! Watch Out! possible ELECTRIC SHOCK, MOVING PARTS, and HOT PARTS hazards. Consult symbols and related instructions below for necessary actions to avoid the hazards.

## 1-2. Arc Welding Hazards

### WARNING

The symbols shown below are used throughout this manual to call attention to and identify possible hazards. When you see the symbol, watch out, and follow the related instructions to avoid the hazard. The safety information given below is only a summary of the more complete safety information found in the Safety Standards listed in Section 1-5. Read and follow all Safety Standards.

Only qualified persons should install, operate, maintain, and repair this unit.

During operation, keep everybody, especially children, away.

	<p><b>ELECTRIC SHOCK can kill.</b></p> <p>Touching live electrical parts can cause fatal shocks or severe burns. The electrode and work circuit is electrically live whenever the output is on. The input power circuit and machine internal circuits are also live when power is on. In semiautomatic or automatic wire welding, the wire, wire reel, drive roll housing, and all metal parts touching the welding wire are electrically live. Incorrectly installed or improperly grounded equipment is a hazard.</p>	<p>terminal in disconnect box or that cord plug is connected to a properly grounded receptacle outlet.</p> <ol style="list-style-type: none"> <li>When making input connections, attach proper grounding conductor first – double-check connections.</li> <li>Frequently inspect input power cord for damage or bare wiring – replace cord immediately if damaged – bare wiring can kill.</li> <li>Turn off all equipment when not in use.</li> <li>Do not use worn, damaged, undersized, or poorly spliced cables.</li> <li>Do not drape cables over your body.</li> <li>If earth grounding of the workpiece is required, ground it directly with a separate cable – do not use work clamp or work cable.</li> <li>Do not touch electrode if you are in contact with the work, ground, or another electrode from a different machine.</li> <li>Use only well-maintained equipment. Repair or replace damaged parts at once. Maintain unit according to manual.</li> <li>Wear a safety harness if working above floor level.</li> <li>Keep all panels and covers securely in place.</li> <li>Clamp work cable with good metal-to-metal contact to workpiece or worktable as near the weld as practical.</li> </ol>
<ol style="list-style-type: none"> <li>Do not touch live electrical parts.</li> <li>Wear dry, hole-free insulating gloves and body protection.</li> <li>Insulate yourself from work and ground using dry insulating mats or covers big enough to prevent any physical contact with the work or ground.</li> <li>Disconnect input power or stop engine before installing or servicing this equipment. Lockout/tagout input power according to OSHA 29 CFR 1910.147 (see Safety Standards).</li> <li>Properly install and ground this equipment according to its Owner's Manual and national, state, and local codes.</li> <li>Always verify the supply ground – check and be sure that input power cord ground wire is properly connected to ground</li> </ol>		

	<p><b>ARC RAYS can burn eyes and skin; NOISE can damage hearing; FLYING SLAG OR SPARKS can injure eyes.</b></p> <p>Arc rays from the welding process produce intense visible and invisible (ultraviolet and infrared) rays that can burn eyes and skin. Noise from some processes can damage hearing. Chipping, grinding, and welds cooling throw off pieces of metal or slag.</p>	<p><b>ARC RAYS</b></p> <ol style="list-style-type: none"> <li>Wear a welding helmet fitted with a proper shade of filter to protect your face and eyes when welding or watching (see ANSI Z49.1 and Z87.1 listed in Safety Standards).</li> <li>Wear approved safety glasses with side shields.</li> <li>Use protective screens or barriers to protect others from flash and glare; warn others not to watch the arc.</li> <li>Wear protective clothing made from durable, flame-resistant material (wool and leather) and foot protection.</li> </ol>
<p><b>NOISE</b></p> <ol style="list-style-type: none"> <li>Use approved ear plugs or ear muffs if noise level is high.</li> </ol>		

	<p><b>FUMES AND GASES can be hazardous to your health.</b></p> <p>Welding produces fumes and gases. Breathing these fumes and gases can be hazardous to your health.</p>	<ol style="list-style-type: none"> <li>Work in a confined space only if it is well ventilated, or while wearing an air-supplied respirator. Always have a trained watchperson nearby. Welding fumes and gases can displace air and lower the oxygen level causing injury or death. Be sure the breathing air is safe.</li> <li>Do not weld in locations near degreasing, cleaning, or spraying operations. The heat and rays of the arc can react with vapors to form highly toxic and irritating gases.</li> <li>Do not weld on coated metals, such as galvanized, lead, or cadmium plated steel, unless the coating is removed from the weld area, the area is well ventilated, and if necessary, while wearing an air-supplied respirator. The coatings and any metals containing these elements can give off toxic fumes if welded.</li> </ol>
<ol style="list-style-type: none"> <li>Keep your head out of the fumes. Do not breathe the fumes.</li> <li>If inside, ventilate the area and/or use exhaust at the arc to remove welding fumes and gases.</li> <li>If ventilation is poor, use an approved air-supplied respirator.</li> <li>Read the Material Safety Data Sheets (MSDSs) and the manufacturer's instruction for metals, consumables, coatings, cleaners, and degreasers.</li> </ol>		

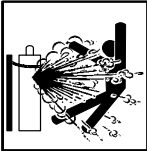

**CYLINDERS can explode if damaged.**

Shielding gas cylinders contain gas under high pressure. If damaged, a cylinder can explode. Since gas cylinders are normally part of the welding process, be sure to treat them carefully.

1. Protect compressed gas cylinders from excessive heat, mechanical shocks, slag, open flames, sparks, and arcs.
2. Install cylinders in an upright position by securing to a stationary support or cylinder rack to prevent falling or tipping.
3. Keep cylinders away from any welding or other electrical circuits.

4. Never drape a welding torch over a gas cylinder.
5. Never allow a welding electrode to touch any cylinder.
6. Never weld on a pressurized cylinder – explosion will result.
7. Use only correct shielding gas cylinders, regulators, hoses, and fittings designed for the specific application; maintain them and associated parts in good condition.
8. Turn face away from valve outlet when opening cylinder valve.
9. Keep protective cap in place over valve except when cylinder is in use or connected for use.
10. Read and follow instructions on compressed gas cylinders, associated equipment, and CGA publication P-1 listed in Safety Standards.



**WELDING can cause fire or explosion.**

Welding on closed containers, such as tanks, drums, or pipes, can cause them to blow up. Sparks can fly off from the welding arc. The flying sparks, hot workpiece, and hot equipment can cause fires and burns. Accidental contact of electrode to metal objects can cause sparks, explosion, overheating, or fire. Check and be sure the area is safe before doing any welding.

1. Protect yourself and others from flying sparks and hot metal.
2. Do not weld where flying sparks can strike flammable material.
3. Remove all flammables within 35 ft (10.7 m) of the welding arc. If this is not possible, tightly cover them with approved covers.
4. Be alert that welding sparks and hot materials from welding can easily go through small cracks and openings to adjacent areas.
5. Watch for fire, and keep a fire extinguisher nearby.

6. Be aware that welding on a ceiling, floor, bulkhead, or partition can cause fire on the hidden side.
7. Do not weld on closed containers such as tanks, drums, or pipes, unless they are properly prepared according to AWS F4.1 (see Safety Standards).
8. Connect work cable to the work as close to the welding area as practical to prevent welding current from traveling long, possibly unknown paths and causing electric shock and fire hazards.
9. Do not use welder to thaw frozen pipes.
10. Remove stick electrode from holder or cut off welding wire at contact tip when not in use.
11. Wear oil-free protective garments such as leather gloves, heavy shirt, cuffless trousers, high shoes, and a cap.
12. Remove any combustibles, such as a butane lighter or matches, from your person before doing any welding.

**1-3. Engine Hazards**

**⚠ WARNING**



**ENGINE EXHAUST GASES can kill.**

Engines produce harmful exhaust gases.

1. Use equipment outside in open, well-ventilated areas.
2. If used in a closed area, vent engine exhaust outside and away from any building air intakes.



**ENGINE FUEL can cause fire or explosion.**

Engine fuel is highly flammable.

1. Stop engine and let it cool off before checking or adding fuel.

2. Do not add fuel while smoking or if unit is near any sparks or open flames.
3. Do not overfill tank – allow room for fuel to expand.
4. Do not spill fuel. If fuel is spilled, clean up before starting engine.



**MOVING PARTS can cause injury.**

Moving parts, such as fans, rotors, and belts can cut fingers and hands and catch loose clothing.

1. Keep all doors, panels, covers, and guards closed and securely in place.
2. Stop engine before installing or connecting unit.

3. Have only qualified people remove guards or covers for maintenance and troubleshooting as necessary.
4. To prevent accidental starting during servicing, disconnect negative (-) battery cable from battery.
5. Keep hands, hair, loose clothing, and tools away from moving parts.
6. Reinstall panels or guards and close doors when servicing is finished and before starting engine.

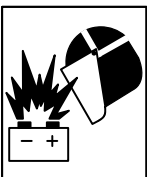

**SPARKS can cause BATTERY GASES TO EXPLODE; BATTERY ACID can burn eyes and skin.**

Batteries contain acid and generate explosive gases.

1. Always wear a face shield when working on a battery.
2. Stop engine before disconnecting or connecting battery cables.
3. Do not allow tools to cause sparks when working on a battery.
4. Do not use welder to charge batteries or jump start vehicles.
5. Observe correct polarity (+ and -) on batteries.











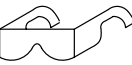

**STEAM AND PRESSURIZED HOT COOLANT can burn face, eyes, and skin.**

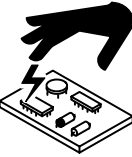
It is best to check coolant level when engine is cold to avoid scalding.

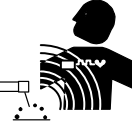
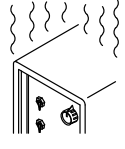
1. If the engine is warm and checking is needed, follow steps 2 and 3.
2. Wear safety glasses and gloves and put a rag over cap.
3. Turn cap slightly and let pressure escape slowly before completely removing cap.

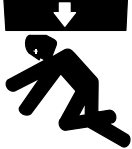
## 1-4. Additional Installation, Operation, And Maintenance Hazards

 <b>WARNING</b>			
	<b>MOVING PARTS can cause injury.</b> <ol style="list-style-type: none"> <li>Before working of generator, remove spark plugs or injectors to keep engine from kicking back or starting.</li> <li>Block flywheel so that it will not turn while working on generator components.</li> </ol>		<b>READ INSTRUCTIONS.</b> <ol style="list-style-type: none"> <li>Use only genuine MILLER replacement parts.</li> <li>Reinstall injectors and bleed air from fuel system according to engine manual.</li> </ol>
	<b>FLYING PIECES OF METAL or DIRT can injure eyes.</b> <ol style="list-style-type: none"> <li>Wear safety glasses with side shields or face shield.</li> </ol>		<b>DO NOT LET ENGINE EXHAUST SPARKS CAUSE FIRE.</b> <ol style="list-style-type: none"> <li>Use approved engine exhaust spark arrestor in required areas – see applicable codes.</li> </ol>
	<b>STATIC ELECTRICITY can damage parts on circuit boards.</b> <ol style="list-style-type: none"> <li>Put on grounded wrist strap BEFORE handling boards or parts.</li> <li>Use proper static-proof bags and boxes to store, move, or ship PC boards.</li> </ol>		<b>LOW VOLTAGE AND FREQUENCY CAN DAMAGE electrical equipment such as MOTORS.</b> <ol style="list-style-type: none"> <li>Turn off or unplug equipment before starting or stopping engine.</li> </ol>
	<b>MAGNETIC FIELDS FROM HIGH CURRENTS can affect pacemaker operation.</b> <ol style="list-style-type: none"> <li>Pacemaker wearers keep away.</li> <li>Wearers should consult their doctor before going near arc welding, gouging, or spot welding operations.</li> </ol>		<b>OVERUSE can cause OVERHEATED EQUIPMENT.</b> <ol style="list-style-type: none"> <li>Allow cooling period.</li> <li>Reduce current or reduce duty cycle before starting to weld again.</li> <li>Follow rated duty cycle.</li> </ol>
	<b>HOT PARTS can cause severe burns.</b> <ol style="list-style-type: none"> <li>Allow cooling period before maintaining.</li> <li>Wear protective gloves and clothing when working on a hot engine.</li> </ol>		<b>TILTING OF TRAILER can cause injury.</b> <ol style="list-style-type: none"> <li>Use tongue jack or blocks to support weight.</li> <li>Properly install welding generator onto trailer according to instructions supplied with trailer.</li> </ol>
	<b>FALLING EQUIPMENT can cause serious personal injury and equipment damage.</b> <ol style="list-style-type: none"> <li>Use lifting eye to lift unit only, NOT running gear, gas cylinders, or any other accessories.</li> <li>Use equipment of adequate capacity to lift unit.</li> </ol>		<b>BATTERY ACID can BURN SKIN AND EYES.</b> <ol style="list-style-type: none"> <li>Do not tip.</li> <li>Replace damaged battery.</li> <li>Flush eyes and skin immediately with water.</li> </ol>

## 1-5. Principal Safety Standards













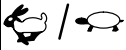





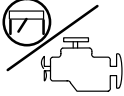

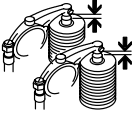

<p><i>Safety in Welding and Cutting</i>, ANSI Standard Z49.1, from American Welding Society, 550 N.W. LeJeune Rd, Miami FL 33126</p> <p><i>Safety and Health Standards</i>, OSHA 29 CFR 1910, from Superintendent of Documents, U.S. Government Printing Office, Washington, D.C. 20402.</p> <p><i>Recommended Safe Practices for the Preparation for Welding and Cutting of Containers That Have Held Hazardous Substances</i>, American Welding Society Standard AWS F4.1, from American Welding Society, 550 N.W. LeJeune Rd, Miami, FL 33126</p> <p><i>National Electrical Code</i>, NFPA Standard 70, from National Fire Protection Association, Batterymarch Park, Quincy, MA 02269.</p>	<p><i>Safe Handling of Compressed Gases in Cylinders</i>, CGA Pamphlet P-1, from Compressed Gas Association, 1235 Jefferson Davis Highway, Suite 501, Arlington, VA 22202.</p> <p><i>Code for Safety in Welding and Cutting</i>, CSA Standard W117.2, from Canadian Standards Association, Standards Sales, 178 Rexdale Boulevard, Rexdale, Ontario, Canada M9W 1R3.</p> <p><i>Safe Practices For Occupation And Educational Eye And Face Protection</i>, ANSI Standard Z87.1, from American National Standards Institute, 1430 Broadway, New York, NY 10018.</p> <p><i>Cutting And Welding Processes</i>, NFPA Standard 51B, from National Fire Protection Association, Batterymarch Park, Quincy, MA 02269.</p>
--	---

## 1-6. EMF Information

<p>Considerations About Welding And The Effects Of Low Frequency Electric And Magnetic Fields</p> <p>The following is a quotation from the General Conclusions Section of the U.S. Congress, Office of Technology Assessment, <i>Biological Effects of Power Frequency Electric &amp; Magnetic Fields – Background Paper</i>, OTA-BP-E-53 (Washington, DC: U.S. Government Printing Office, May 1989): “. . . there is now a very large volume of scientific findings based on experiments at the cellular level and from studies with animals and people which clearly establish that low frequency magnetic fields can interact with, and produce changes in, biological systems. While most of this work is of very high quality, the results are complex. Current scientific understanding does not yet allow us to interpret the evidence in a single coherent framework. Even more frustrating, it does not yet allow us to draw definite conclusions about questions of possible risk or to offer clear science-based advice on strategies to minimize or avoid potential risks.”</p>	<p>To reduce magnetic fields in the workplace, use the following procedures:</p> <ol style="list-style-type: none"> <li>Keep cables close together by twisting or taping them.</li> <li>Arrange cables to one side and away from the operator.</li> <li>Do not coil or drape cables around the body.</li> <li>Keep welding power source and cables as far away as practical.</li> <li>Connect work clamp to workpiece as close to the weld as possible.</li> </ol> <p><b>About Pacemakers:</b></p> <p>The above procedures are also recommended for pacemaker wearers. Consult your doctor for complete information.</p>
--	--

# SECTION 2 – DEFINITIONS

## 2-1. Symbol Definitions

	Stop Engine		Fast (Run, Weld/Power)		Fast/Slow (Run/Idle)		Slow (Idle)
	Start Engine		Read Operator's Manual	<b>A</b>	Amperes	<b>V</b>	Volts
	Engine Oil		Fuel		Battery (Engine)		Engine
	Engine Choke		Check Valve Clearance		Do not switch while welding		Work Connection
<b>+</b>	Positive	<b>—</b>	Negative		Alternating Current (AC)		Output
	Welding Arc (Electrode)		Gas Metal Arc Welding (GMAW), Wire		Shielded Metal Arc Welding (SMAW), Stick		Gas Tungsten Arc Welding (TIG)
<b>h</b>	Hours	<b>s</b>	Seconds		Time		Protective Earth (Ground)
			Temperature		Circuit Breaker		

# SECTION 3 – INSTALLATION

## 3-1. Installing Welding Generator

**Movement**

**Airflow Clearance**

**Location**

---

**Grounding**

Electrically bond generator frame to vehicle frame by metal-to-metal contact.

- 1 Generator Base
- 2 Metal Vehicle Frame
- 3 Equipment Grounding Terminal
- 4 Grounding Cable

Use #10 AWG or larger insulated copper wire.

install1\* 3/96 – Ref. ST-800 652 / Ref. ST-800 477-A / ST-158 936-A / S-0854

## 3-2. Dimensions, Weights, And Operating Angles

Engine End

ST-800 426

**Dimensions**

Height	31 in (787 mm)
Width	18-3/4 in (476 mm)
Depth	46 in (1164 mm)
A	18 in (457 mm)
B	16-1/2 in (419 mm)
C	3/4 in (19 mm)
D	3-1/8 in (79 mm)
E	32-3/4 in (832 mm)
F	45-1/2 in (1156 mm)
G	13/32 in (10 mm) Dia.

▲ Do not exceed operating angles while running or engine damage will occur.

▲ Do not move or operate unit where it could tip.

angles\_1 3/96

Weight
Net: 567 lb (258 kg)
Ship: 608 lb (276 kg)

### 3-3. Fuel Consumption

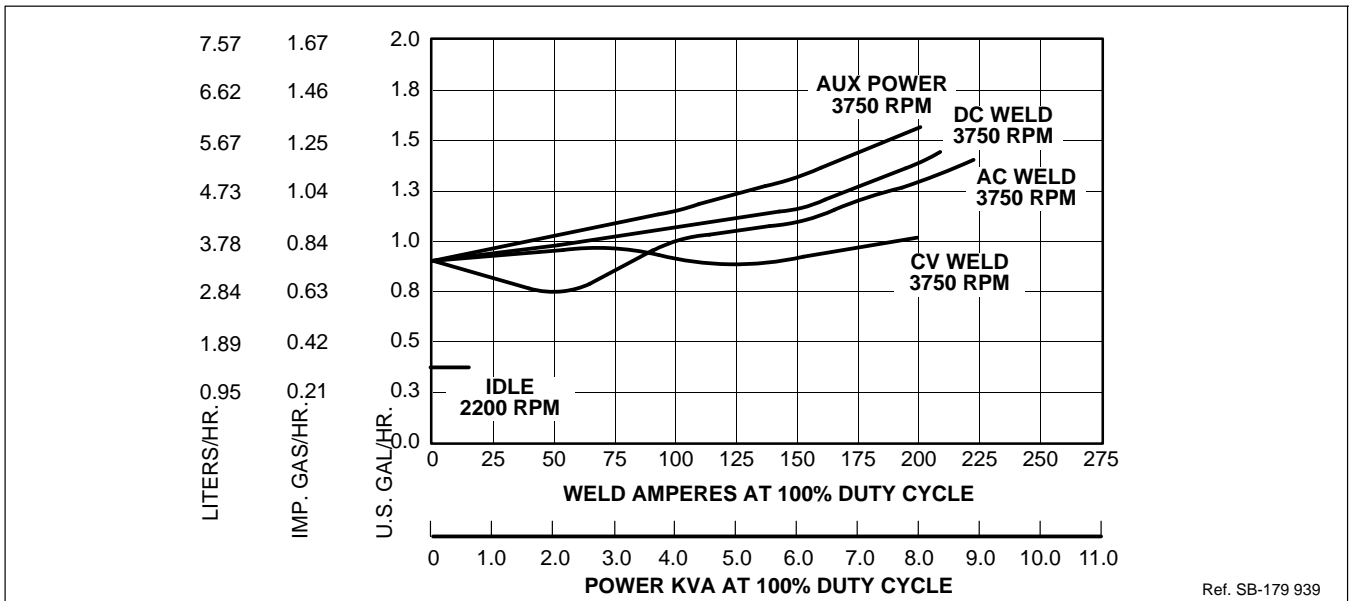

Ref. SB-179 939

### 3-4. Engine Prestart Checks

Check all fluids daily. Engine must be cold and on a level surface. Unit is shipped with 10W30 engine oil.

- Low Oil Pressure Shutdown Switch  
Engine stops if oil pressure gets too low.
- Anti-Icing Control  
Use control to prevent carburetor icing in cold weather.

The diagram shows a top-down view of the engine compartment with callouts for:
 

- Oil Level:** A dipstick is shown with a 'Full' mark. A circular inset shows the dipstick being inserted into the oil filler neck.
- Fuel Level:** A fuel tank is shown with a 'Full' mark. A circular inset shows the fuel tank with a '1/2 in (13 mm)' measurement and a 'Full' label.
- Temperature:** A circular inset shows a temperature gauge with a needle pointing to '45°F (7°C)'. The gauge has 'Below' and 'Above' markings.
- Anti-Icing Control:** A circular inset shows a control knob being turned.

Ref. ST-801 188-A / Ref. ST-801 221



### 3-5. Connecting The Battery

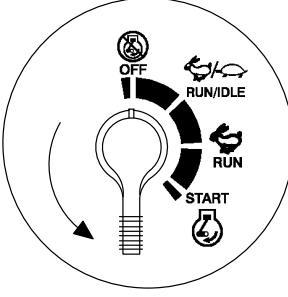
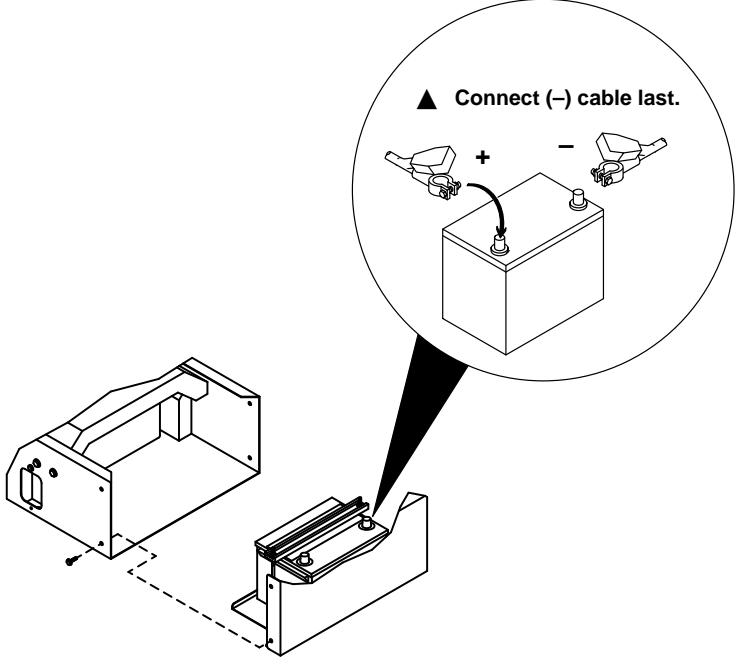

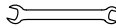

Tools Needed:

 3/8, 1/2 in

Ref. ST-800 394-B / Ref. ST-178 079-A / Ref. S-0756-D

### 3-6. Weld Output Terminals And Selecting Cable Sizes



**▲ ARC WELDING can cause Electromagnetic Interference.**

To reduce possible interference, keep weld cables as short as possible, close together, and down low, such as on the floor. Locate welding operation 100 meters from any sensitive electronic equipment. Be sure this welding machine is installed and grounded according to this manual. If interference still occurs, the user must take extra measures such as moving the welding machine, using shielded cables, using line filters, or shielding the work area.



**Weld Output Terminals**

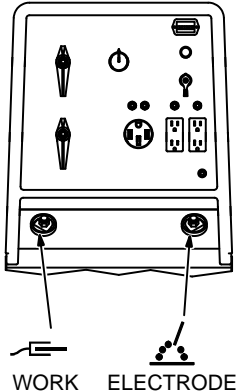

ST-800 396-A

Welding Amperes	Total Cable (Copper) Length In Weld Circuit Not Exceeding							
	100 ft (30 m) Or Less	150 ft (45 m)	200 ft (60 m)	250 ft (70 m)	300 ft (90 m)	350 ft (105 m)	400 ft (120 m)	
	10 – 60% Duty Cycle	60 – 100% Duty Cycle	10 – 100% Duty Cycle					
100	4	4	4	3	2	1	1/0	1/0
150	3	3	2	1	1/0	2/0	3/0	3/0
200	3	2	1	1/0	2/0	3/0	4/0	4/0
250	2	1	1/0	2/0	3/0	4/0	2-2/0	2-2/0
300	1	1/0	2/0	3/0	4/0	2-2/0	2-3/0	2-3/0
350	1/0	2/0	3/0	4/0	2-2/0	2-3/0	2-3/0	2-4/0

Weld cable size (AWG) is based on either a 4 volts or less drop or a current density of at least 300 circular mils per ampere.

S-0007-D

# SECTION 4 – OPERATING WELDING GENERATOR

## 4-1. Front Panel Controls

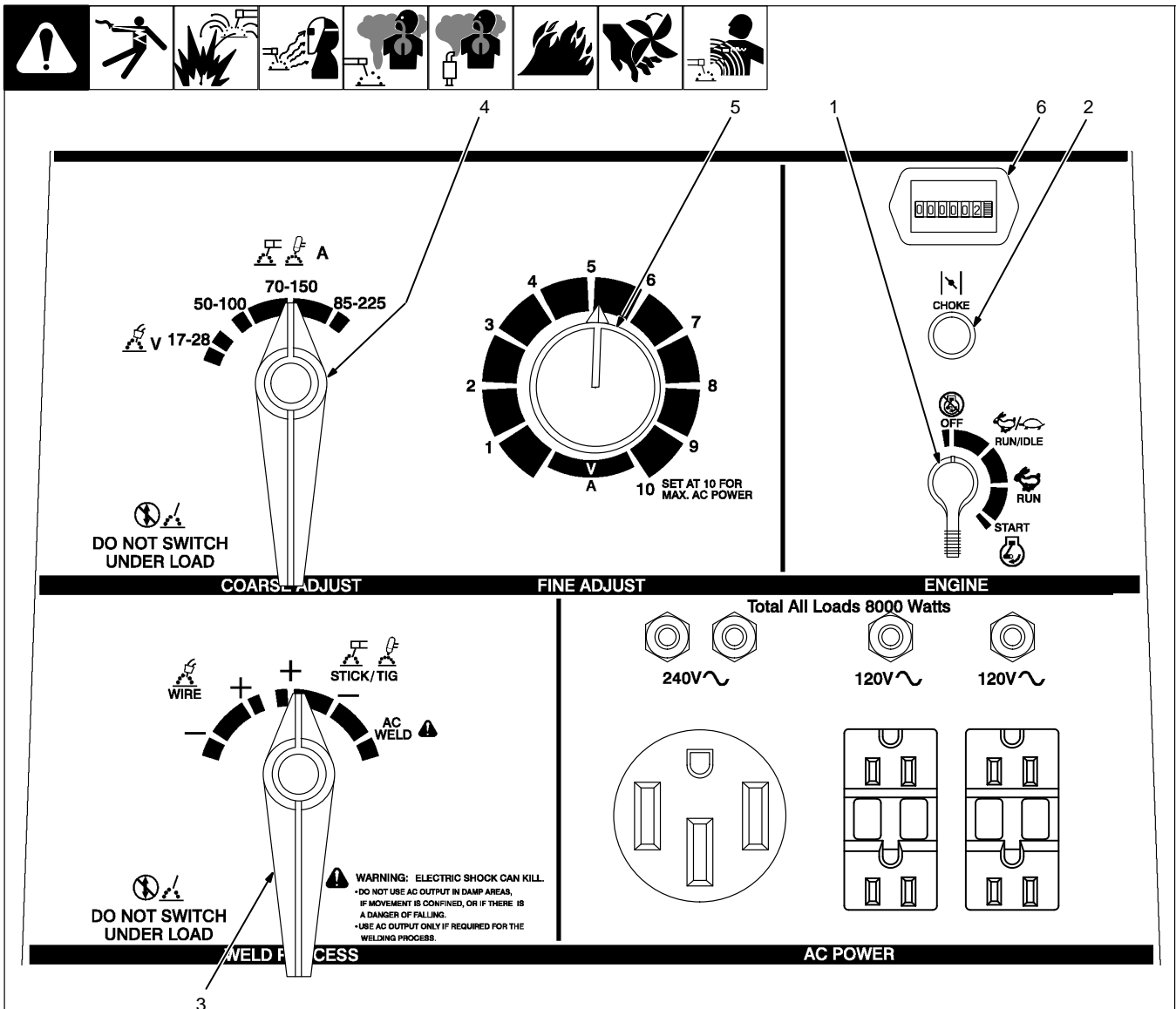

Ref. ST-178 079-A

### 1 Engine Control Switch

Use switch to start engine, select speed, and stop engine. In Run/Idle position, engine runs at idle speed at no load, and weld/power speed under load. In Run position, engine runs at weld/power speed.

**☞** Place switch in Run position to operate most GMAW equipment.

### 2 Engine Choke Control

Use control to change engine air-fuel mix.

**To Start:** pull out choke and turn Engine Control switch to Start position. Release switch and slowly push choke in when en-

gine starts. Do not crank engine if engine is still turning. Set anti-icing control (see Section 3-4).

**To Stop:** turn Engine Control switch to Off position.

### 3 Weld Process Selector Switch

Use switch to select type of weld output.

Use a positive (+) position for Direct Current Electrode Positive (DCEP) and a negative (-) position for Direct Current Electrode Negative (DCEN). Use AC position for alternating current.

### 4 Coarse Adjust Switch

Use switch to select weld amperage range when Weld Process Selector switch is in Stick/Tig position, or voltage range when switch is in Wire position.

**☞** For best arc starts, use lowest amperage range possible.

### 5 Fine Adjust Control

Use control to select weld amperage (Stick/Tig) or voltage (Wire) within the range selected by the Coarse Adjust switch. Control may be adjusted while welding. Weld output would be 110 A DC based on control settings shown (50% of 70 to 150 A).

### 6 Engine Hour Meter

## 4-2. Duty Cycle

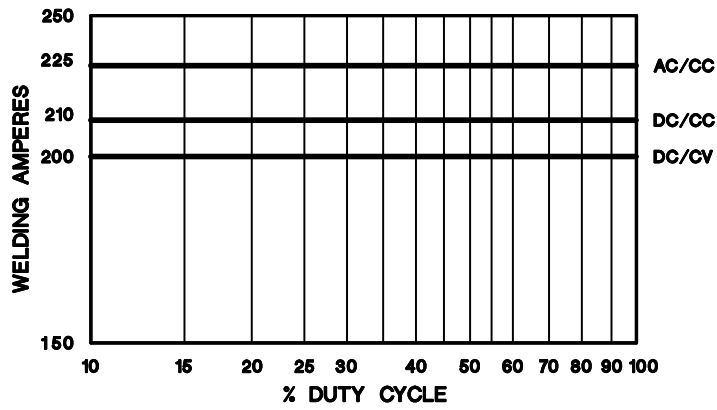

Duty cycle is the percentage of 10 minutes that unit can weld at rated load without overheating.

▲ Exceeding duty cycle can damage unit and void warranty.

100% Duty Cycle at 225 Amperes AC, 210 Amperes CC/DC, 200 Amperes CV/DC

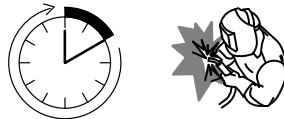

Continuous Welding

SB-119 454-A

# SECTION 5 – OPERATING AUXILIARY EQUIPMENT

## 5-1. Standard Receptacles

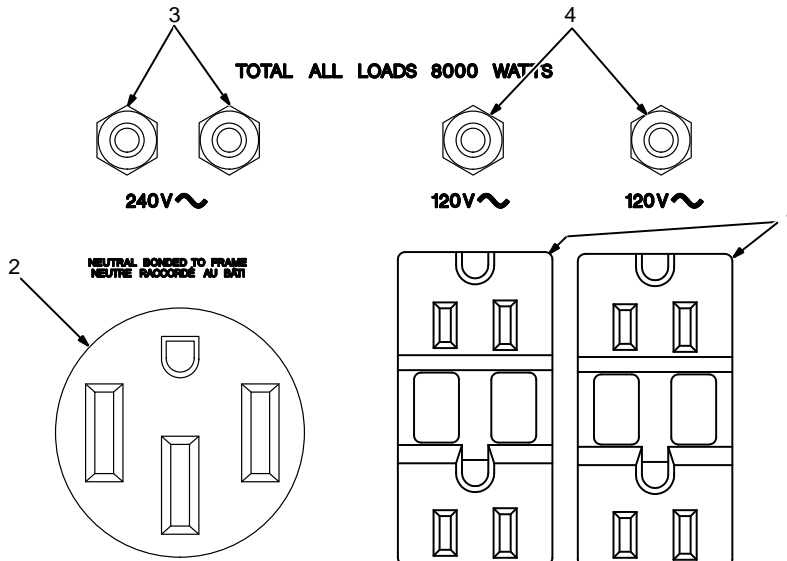

### AC POWER

☞ Auxiliary power decreases as weld current increases.

Set Fine Adjust control R1 at 10 for full auxiliary power.

- 120 V 15 A AC Receptacles GFCI-2 And GFCI-3

GFCI-2 and GFCI-3 supply 60 Hz single-phase power at weld/power speed. Maximum output from each receptacle is 2.4 kVA/kW (CSA: 1.8 kVA/kW).

If a ground fault is detected, Reset button pops out and the circuit opens to disconnect the faulty equipment. Check for faulty tools, cords, etc. connected to the receptacle. Press reset button to resume operation.

☞ At least once a month, run engine at weld/power speed and press Test button to verify GFCI is working properly.

- 240 V 50 A AC Receptacle RC1

RC1 supplies 60 Hz single-phase power at weld/power speed. Maximum output is 8 kVA/kW.

- Circuit Breakers CB1 And CB2

CB1 and CB2 protect RC1 from overload. If CB1 or CB2 opens, RC1 and one of the 120 volt receptacles does not work. 120 volts may still be present at RC1.

- Circuit Breakers CB3 And CB4

CB3 and CB4 protect GFCI-2 and GFCI-3 from overload. If CB3 or CB4 opens, the receptacle does not work.

☞ If a circuit breaker continues to open, contact a Factory Authorized Service Agent.

Total output of receptacles limited to 8 kVA/kW. Example: If 20 A is drawn from GFCI-2 and GFCI-3, only 13 A is available at RC1:

$$2 \times (120 \text{ V} \times 20 \text{ A}) + (240 \text{ V} \times 13 \text{ A}) = 7.9 \text{ kVA/kW}$$

## 5-2. Optional Auxiliary Power Receptacles

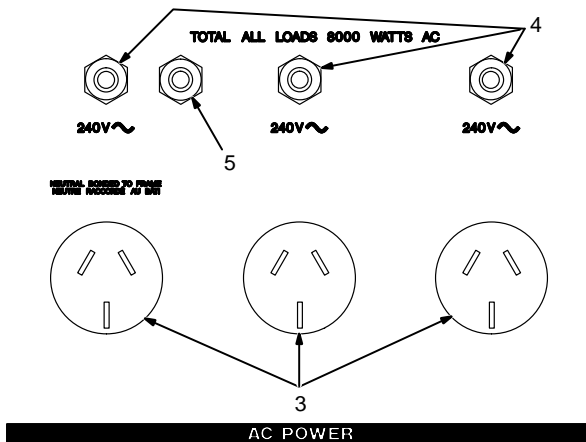
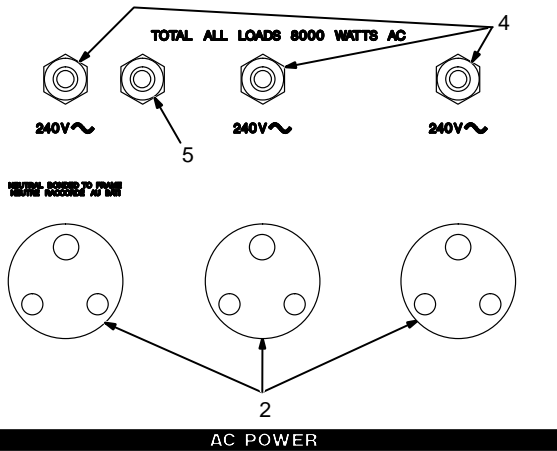
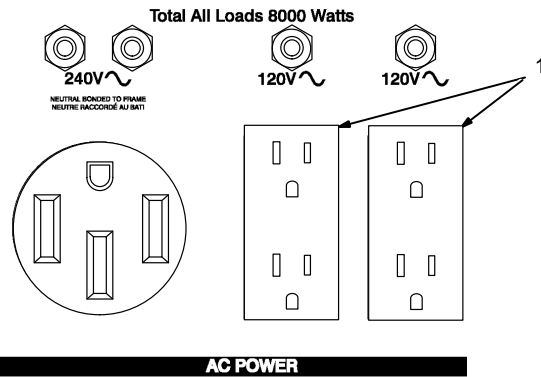

▲ If unit does not have GFCI receptacles, use GFCI-protected extension cord.

☞ Auxiliary power decreases as weld current increases.

Set Fine Adjust control R1 at 10 for full auxiliary power.

Combined output of all receptacles limited to 8 kVA/kW rating of the generator.

### 120 Volt Receptacle Option

- 120 V 15 A AC Receptacles RC2 And RC3

RC2 and RC3 supply 60 Hz single-phase power at weld/power speed. Maximum output from RC2 or RC3 is 2.4 kVA/kW (CSA: 1.8 kVA/kW). Circuit breaker protection is the same as standard receptacles.

### South African And Australian Receptacle Options

- 240 V 16 A AC South African Receptacles RC1, RC2, And RC3
- 240 V 15 A AC Australian Receptacles RC1, RC2, And RC3

Receptacles supply 60 Hz single-phase power at weld/power speed. Maximum output from each receptacle is 3.6 kVA/kW.

- Circuit Breakers CB1, CB2, CB3

CB1, CB2, and CB3 protect RC1, RC2, and RC3 from overload. If a circuit breaker opens, the receptacle does not work. Press button to reset breaker.

- Circuit Breaker CB4

CB4 protects all the receptacles from overload. If CB4 opens, none of the receptacles work.

☞ If a circuit breaker continues to open, contact a Factory Authorized Service Agent.

### 5-3. Wiring Optional 240 Volt Plug



Current Available In Amperes	
240 V Receptacle*	Each 120 V Duplex Receptacle
35	0
30	5
25	10
20	15
15	20
V x A = Watts	

\*One 240 V load or two 120 V loads.

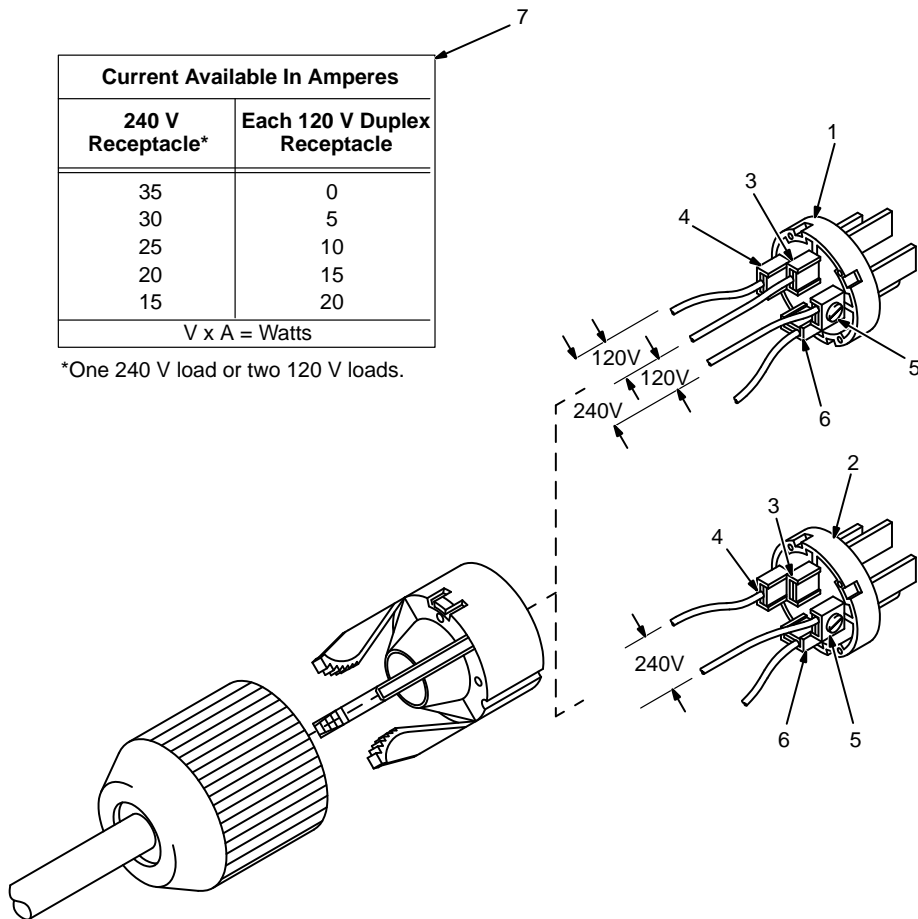

The plug can be wired for a 240 V, 2-wire load or a 120/240V, 3-wire load. See circuit diagram.

1 Plug Wired For 120/240 V, 3-Wire Load

When wired for 120 V loads, each duplex receptacle shares a load with one half of 240 V receptacle.

2 Plug Wired For 240 V, 2-Wire Load

3 Neutral (Silver) Terminal

4 Load 1 (Brass) Terminal

5 Load 2 (Brass) Terminal

6 Ground (Green) Terminal

7 Amperes Available Using 120/240 V Plug

Tools Needed:

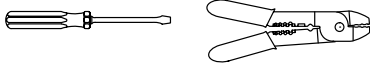









ST-120 813-D

# SECTION 6 – MAINTENANCE AND TROUBLESHOOTING

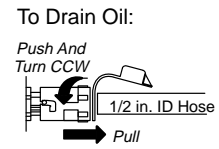
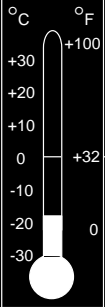
## 6-1. Routine Maintenance

		<p>Recycle engine fluids.</p>	<p>▲ <b>Stop engine before maintaining.</b></p> <p>☞ See also <i>Engine Manual</i> and maintenance label. Service engine more often if used in severe conditions.</p>
<b>8 h</b>			
<p>Wipe Up Spills.</p>		<p>Check Fluid Levels. See Section 3-4.</p>	
<b>20 h</b>			
<p>Check And Clean Optional Spark Arrestor Screen. See Section 6-7.</p>		<p>Service Air Cleaner Foam Element. See Section 6-3.</p>	
<b>50 h</b>			
<p>Clean And Tighten Weld Terminals.</p>			
<b>100 h</b>			
<p>Change Oil. See Section 6-4 And Maintenance Label.</p>		<p>Check Spark Plugs.</p>	
		<p>Check Air Cleaner Paper Element. See Section 6-3.</p>	
<p>Clean Cooling System. See Engine Manual.</p>		<p>Clean And Tighten Battery Connections.</p>	
<b>200 h</b>			
<p>Change Oil Filter. See Section 6-4 And Maintenance Label.</p>		<p>Replace Fuel Filter. See Section 6-4.</p>	
		<p>Replace Unreadable Labels.</p>	
<b>500 h</b>			
<p>Repair Or Replace Cracked Cables.</p>			
<b>1000 h</b>			
<p>OR</p>		<p>Blow Out Or Vacuum Inside. During Heavy Service, Clean Monthly.</p>	

## 6-2. Maintenance Label

KOHLER CH18 GAS ENGINE	
 <p>See Engine Manual for complete engine care. Give engine Specification and Serial Number when ordering parts.</p>	 <p>Air Filter Service . . . . 100 hours or less – see Owner's Manual            Air Filter Element . . . . MILLER 067 272, Kohler 4708303            Air Filter Wrapper . . . . MILLER 067 273, Kohler 2408302</p>
 <p><i>Check daily.</i></p> <div style="border: 1px solid black; padding: 5px; width: fit-content;"> <p>To Drain Oil:</p>  </div>  <p style="text-align: center;"> <math>^{\circ}\text{C}</math>     <math>^{\circ}\text{F}</math>            +30     +100            +20            +10            0     +32            -10            -20     0            -30            5W-20, 5W-30     10W-30, 10W-40         </p>	 <p>12 Volt Battery . . . . . BCI Group 58            Cranking Performance at 0°F (-18°C) . . . . 430 Amps min.</p>
<p>Recommended Oil . . . . API Service Classification SF-SG/CC-CD            Oil Change . . . . . 100 hours            Oil Filter Change . . . . . 200 hours            Oil Filter . . . . . MILLER 066 698, Kohler 1205001            Oil Capacity . . . . . 1.75 qt (1.7 L) or 2 qt (1.9 L) with filter change</p>	 <p>Engine RPM – No Load            Weld/Power . 3700            Idle . . . . . 2200</p>
 <p>Fuel Capacity . . . . . 8.5 gal (32.2 L)            Fuel Grade . . . . . Unleaded, 87 Octane min.            Fuel Filter . . . . . MILLER 066 113, Kohler 2505003</p> <p><i>Gasoline</i></p>	 <p>Spark Plug Gap . . . . . 0.040 in. (1.02 mm)            Spark Plug . . . . . Champion RC-12YC  <i>Use only resistor spark plugs and wires.</i></p>
	 <p>Spark Arrester Inspection And Service . . . . . 20 operating hours - see Owner's Manual</p>

S-173 088

## 6-3. Servicing Air Cleaner

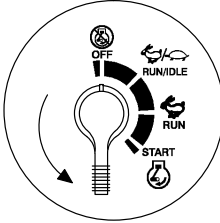

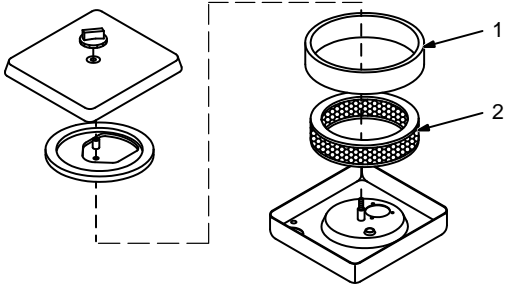



**▲ Stop engine.**  
**▲ Do not run engine without air cleaner or with dirty element.**

1 Precleaner  
 Wash precleaner with soap and water solution. Allow precleaner to air dry completely.  
 Spread 1 tablespoon SAE 30 oil evenly into precleaner. Squeeze out excess oil.

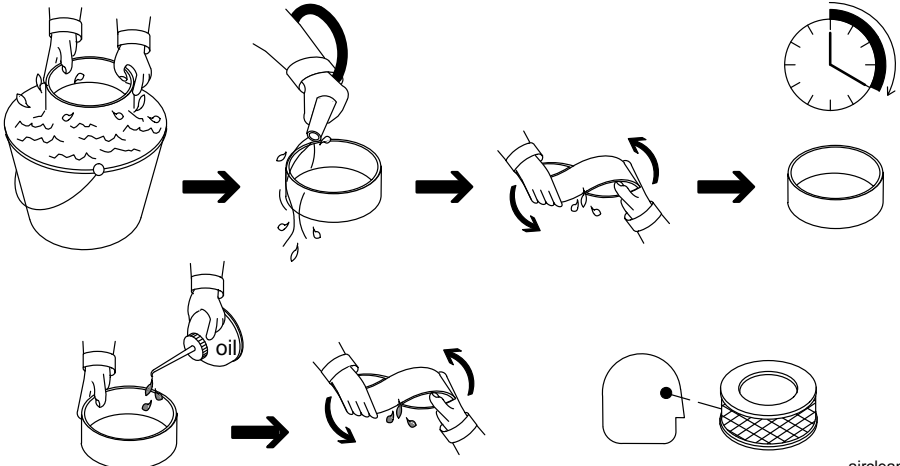
2 Element  
 Replace element if dirty or oily.



aircleaner3 6/96 – ST-156 852 / Ref. ST-178 079-A / S-0759



## 6-4. Changing Engine Oil, Oil Filter, And Fuel Filter

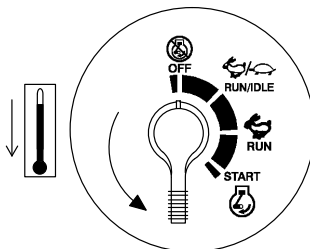

**▲ Stop engine and let cool.**

- 1 Oil Drain Valve
- 2 1/2 ID x 12 in Hose
- 3 Oil Filter
- 4 Oil Fill Cap
- 5 Oil Dipstick

Change engine oil and filter according to engine owner's manual.

**▲ Close valve and valve cap before adding oil and running engine.**

Fill crankcase with new oil to full mark on dipstick (see Section 6-2).

- 6 Fuel Filter
- 7 Fuel Line

Replace line if cracked or worn. Install new filter. Wipe up any spilled fuel.

Start engine, and check for fuel leaks.

**▲ Stop engine, tighten connections as necessary, and wipe up fuel.**

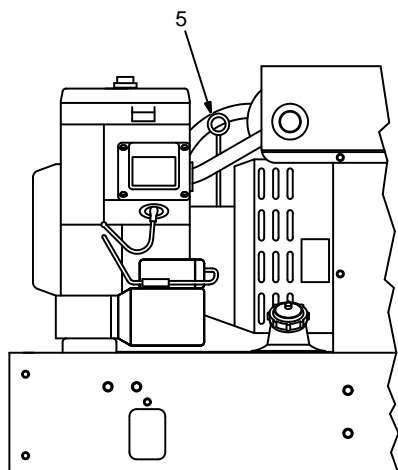
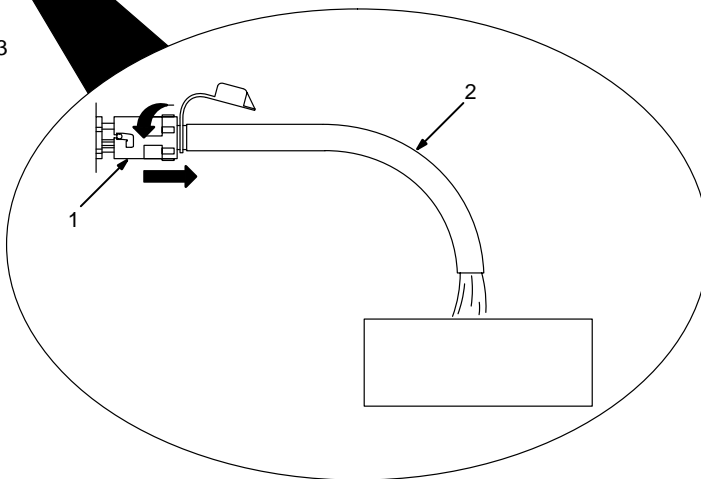
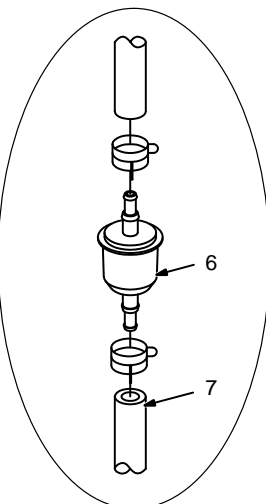
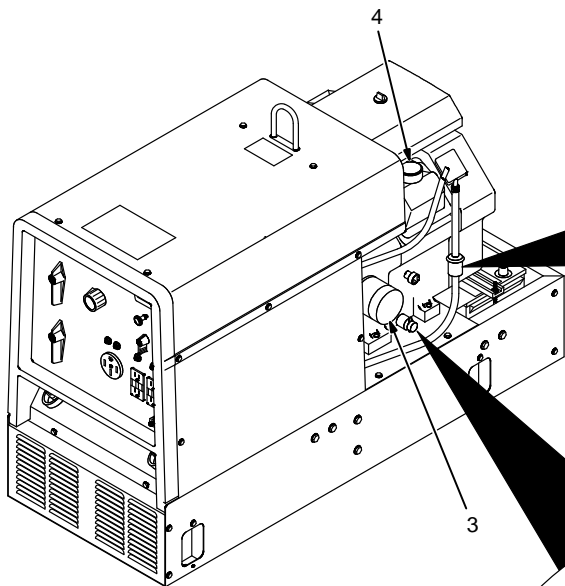

**Tools Needed:**

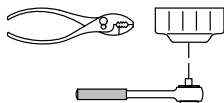

Ref. ST-801 188-A / Ref. ST-801 221 / Ref. ST-178 079-A / ST-800 395 / S-0842

## 6-5. Adjusting Engine Speed



	2200 ± 50 rpm
	3700 ± 50 rpm

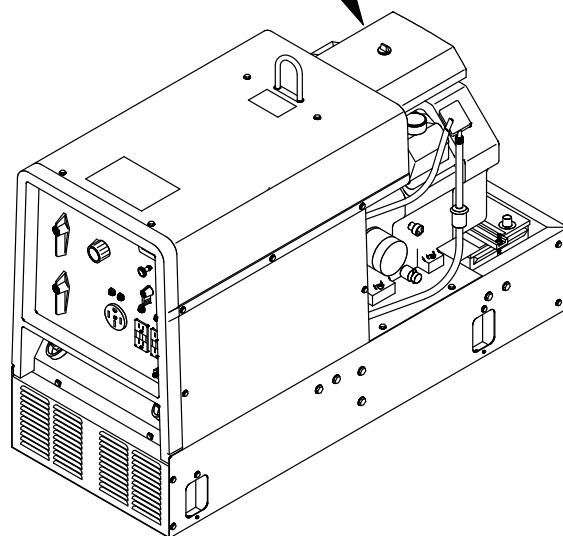
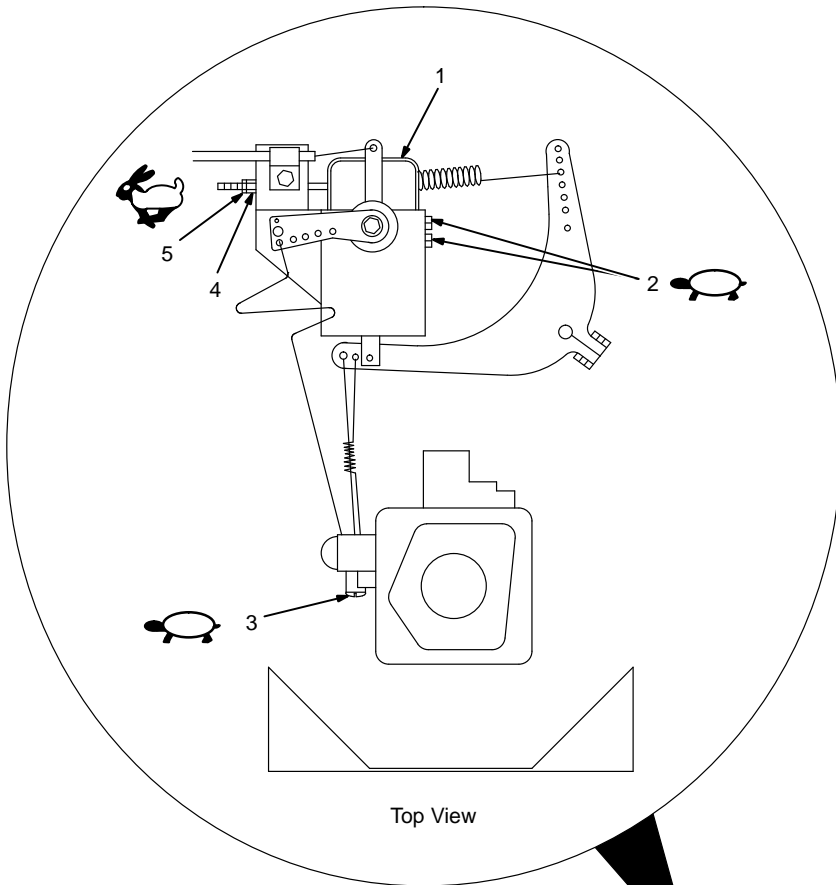

Tools Needed:

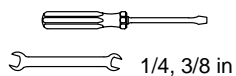

After tuning engine, check engine speeds with a tachometer (see table). If necessary, adjust speeds as follows:

Start engine and run until warm. Turn Fine Adjust control to 10.

### Idle Speed Adjustment

Move Engine Control switch to Run/Idle position.

- 1 Throttle Solenoid
- 2 Mounting Screws
- 3 Idle Speed Screw

Loosen mounting screws. Adjust solenoid position so engine runs at idle speed. If necessary, back out idle speed screw so solenoid can be moved to correct position. Tighten mounting screws. Be sure solenoid linkage works smoothly.

Turn idle speed screw for fine adjustments.

### Weld/Power Speed Adjustment

Move Engine Control switch to Run position.

- 4 Weld/Power Speed Adjustment Nut
- 5 Lock Nut

Loosen lock nut. Turn adjustment nut until engine runs at weld/power speed. Tighten lock nut.

▲ Stop engine.

Ref. ST-801 188-A / ST-801 209-A

## 6-6. Overload Protection

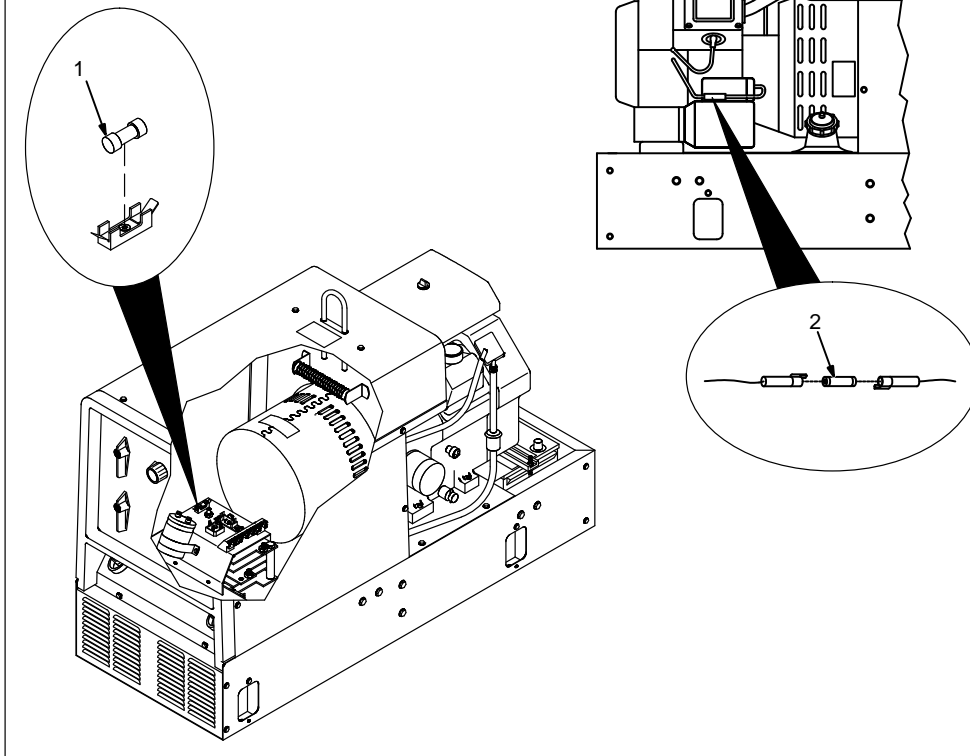

### ▲ Stop engine.

1 Fuse F1 (See Parts List)

F1 protects the generator excitation circuit. If F1 opens, there will be no/low weld and auxiliary power output.

2 Fuse F6 (See Parts List)

F6 protects the engine wiring harness. If F6 opens, the engine does not crank.

Replace any open fuses. Reinstall panel before operating unit.

☞ *If any fuse continues to open, contact Factory Authorized Service Agent.*

Tools Needed:

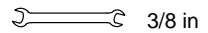
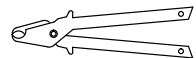

ST-801 226-A / Ref. ST-801 221

## 6-7. Inspecting And Cleaning Optional Spark Arrestor

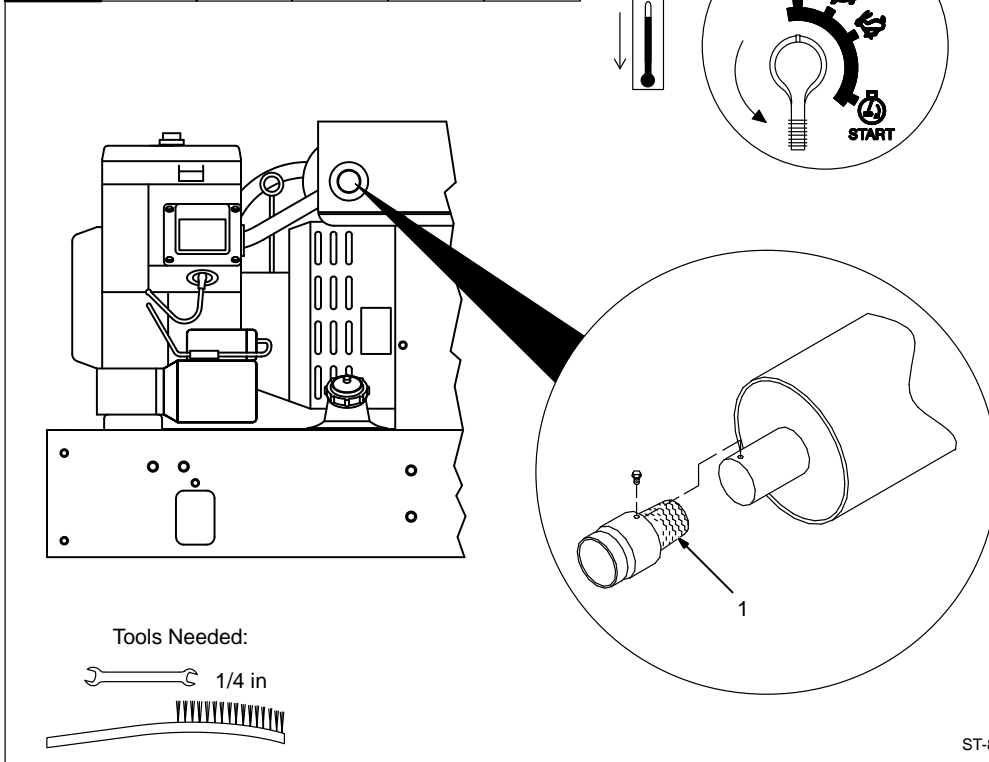
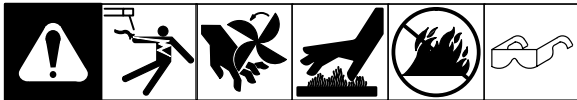

### ▲ Stop engine and let cool.

1 Spark Arrestor Screen

Clean and inspect screen. Replace spark arrestor if screen wires are broken or missing.

Tools Needed:

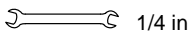

ST-801 206 / Ref. ST-801 221 / Ref. ST-172 782-A

## 6-8. Troubleshooting

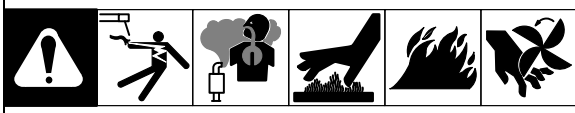

### A. Welding

Trouble	Remedy
No weld output.	Check control settings.
	Check weld connections.
	Check fuse F1 and replace if open (see Section 6-6).
	Be sure all equipment is disconnected from receptacles when starting unit.
	Have Factory Authorized Service Agent check brushes, slip rings, and integrated rectifier SR2.
	Check plug PLG6 connection.
Low weld output.	Check fuse F1 and replace if open (see Section 6-6).
	Check control settings.
	Check and adjust engine speed (see Section 6-5).
	Service air cleaner according to engine manual.
	Have Factory Authorized Service Agent check brushes and slip rings.
High weld output.	Check control settings.
	Check and adjust engine speed (see Section 6-5).
Erratic weld output.	Check control settings.
	Tighten and clean connections to electrode and workpiece.
	Use dry, properly-stored electrodes for SMAW and GTAW.
	Remove excessive coils from weld cables.
	Tighten and clean connections both inside and outside welding generator.
	Check and adjust engine speed (see Section 6-5).
	Have Factory Authorized Service Agent check brushes and slip rings.

### B. Auxiliary Power

Trouble	Remedy
No output at auxiliary power receptacles.	Reset circuit breakers (see Sections 5-1 and 5-2).
	Press receptacle Reset button (see Section 5-1).
	Check fuse F1 and replace if open (see Section 6-6).
	Check plug PLG6 connection.
	Have Factory Authorized Service Agent check brushes, slip rings, and integrated rectifier SR2.
High power output.	Check and adjust engine speed (see Section 6-5).
Low power output.	Check fuse F1 and replace if open (see Section 6-6).
	Increase Fine Adjust control R1 setting.
Erratic power output.	Check fuel level.
	Check and adjust engine speed (see Section 6-5).
	Check receptacle wiring and connections.
	Have Factory Authorized Service Agent check brushes and slip rings.

## C. Engine

Trouble	Remedy
Engine will not crank.	Check fuse F6, and replace if open (see Section 6-6).
	Check battery voltage.
	Check battery connections and tighten if necessary.
	Check plug PLG4 and plug PLG8 connections.
	Have Factory Authorized Service Agent check Engine Control switch S2.
Engine will not start.	Check fuel level.
	Check battery voltage.
	Check battery connections and tighten if necessary.
	Check oil level. Check low oil pressure shutdown switch (see Section 3-4).
	Have Factory Authorized Service Agent check fuel shutoff solenoid FS1.
Engine starts but stops when Engine Control switch returns to Run position.	Check oil level. Check low oil pressure shutdown switch (see parts list for location).
	Check and refill crankcase with proper viscosity oil for operating temperature, if necessary.
Engine stopped during normal operation.	Check fuel level.
	Check oil level. Check low oil pressure shutdown switch (see Section 3-4).
	Periodically recharge battery (approximately every 3 months).
	Replace battery.
	Check voltage regulator and connections according to engine manual.
	Have Factory Authorized Service Agent check fuel shutoff solenoid FS1.
Battery Discharges between uses.	Clean battery, terminals, and posts with baking soda and water solution; rinse with clear water.
	Periodically recharge battery (approximately every 3 months).
	Replace battery.
	Check voltage regulator and connections according to engine manual.
Engine idles but does not come up to weld speed.	Have Factory Authorized Service Agent check auto idle module PC1, and current transformer CT1.
Unstable or sluggish engine speeds.	Readjust throttle linkage if necessary. Check throttle solenoid TS1 for smooth operation.
	Tune-up engine according to engine manual.
Engine does not return to idle speed.	Remove weld and auxiliary power loads.
	Check throttle linkage for smooth, non-binding operation.
	Have Factory Authorized Service Agent check idle module PC1, current transformer CT1, Engine Control switch S2, and throttle solenoid TS1.

# SECTION 7 – ELECTRICAL DIAGRAM

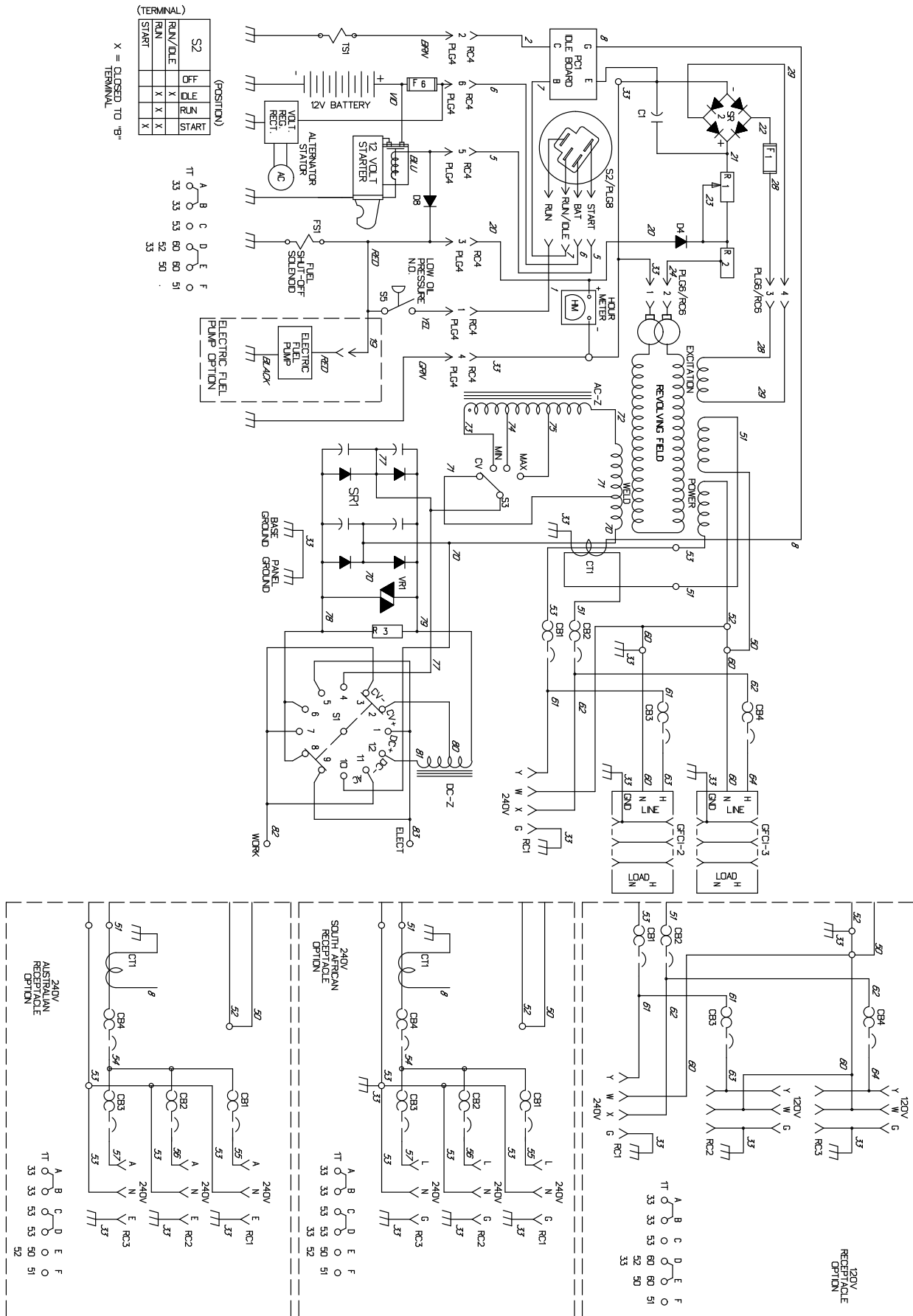

SB-180 690-B

Figure 7-1. Circuit Diagram For Welding Generator

# SECTION 8 – PARTS LIST

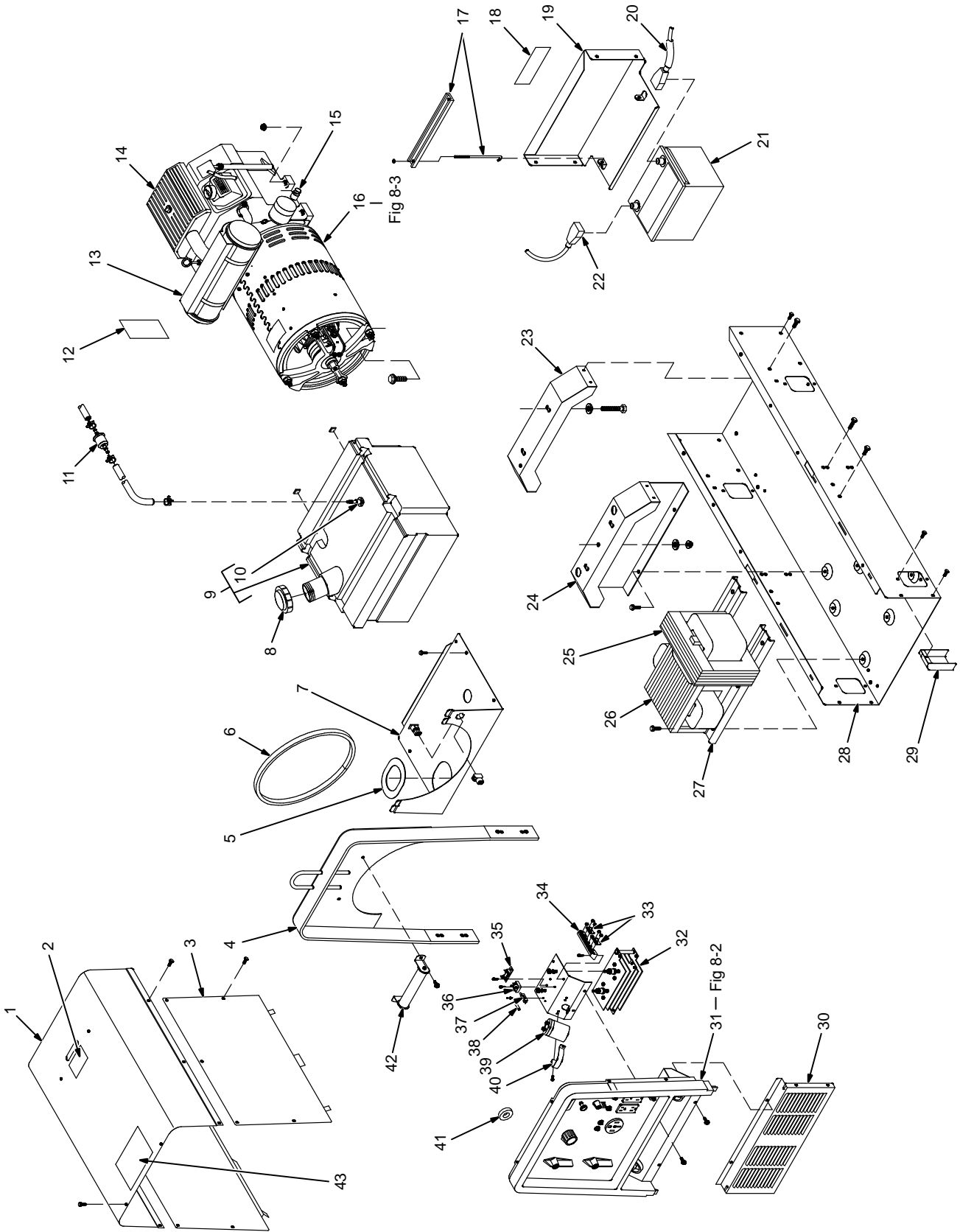

Figure 8-1. Main Assembly

ST-801 432-B

Item No.	Dia. Mkgs.	Part No.	Description	Quantity
1		+159 907	COVER, top	1
1	◆	+169 441	COVER, top	1
2		108 487	LABEL, warning: falling equipment can cause serious injury	1
3		169 329	PANEL, side	2
3	◆	169 442	PANEL, side	2
4		159 914	UPRIGHT, base	1
5		168 640	SEAL, tank fuel filler neck	1
6		164 928	SEAL, barrel 11.78 ID x .378thk	1
7		178 497	PANEL, rear lower	1
8		147 601	CAP, tank screw-on w/vent	1
9		178 498	TANK, fuel 8.5gal (consisting of)	1
10		178 632	FITTING, stand pipe hose .250 x 7.325 lg	1
11		121 652	FILTER KIT, fuel w/clamps	1
12		173 088	LABEL, engine maintenance	1
13		173 065	MUFFLER, exhaust engine w/heat shield (Included w/engine)	1
14		+173 042	ENGINE, gas elec start (consisting of)	1
15		165 271	VALVE, oil drain 3/8-18NPTF	1
	TS1		SOLENOID, 14VDC .53A (see engine parts list)	1
			BRACKET, mtg solenoid (see engine parts list)	1
		180 096	TUNE-UP & FILTER KIT, (consisting of)	1
		066 698	OIL FILTER	1
		121 652	FILTER/CLAMPS, fuel	1
		067 272	ELEMENT, air cleaner	1
		067 273	AIR FILTER, wrapper	1
		067 007	SPARK PLUG	2
16		Fig 8-3	GENERATOR	1
24		182 361	KIT, holddown battery	1
18		168 385	LABEL, warning battery explosion can blind	1
19		+159 917	DOOR, access battery	1
20		173 921	CABLE, bat pos (included w/engine)	1
21		168 037	BATTERY, stor 12V 430crk 75rsv GP58 dry	1
22		082 319	CABLE, bat neg	1
		172 669	CABLE, bat neg	1
23		173 043	BRACKET, mtg engine	1
24		165 660	BRACKET, mtg generator	1
25	DC-Z	165 578	STABILIZER	1
26	AC-Z	176 301	REACTOR	1
27		164 920	BRACKET, mtg stab/reactor	2
28		159 906	PAN, base	1
29		160 844	COVER, base	4
30		+180 628	PANEL, front lower	1
31		Fig 8-2	PANEL, front w/components	1
32	SR1	142 503	RECTIFIER, si 1 ph 300A 400PIV	1
33		173 734	LINK, jumper	2
34	1T	172 661	BLOCK, stud connection 6 position	1
35	D4	135 184	DIODE BOARD	1
36	SR2	035 704	RECTIFIER, integ 40A 800V	1
37		172 731	HOLDER, fuse mintr	1
38	F1	*169 296	FUSE, mintr gl 25A 125V	1
39	C1	176 719	CAPACITOR, elctlt 1000uf 75VDC	1
40		177 136	CLAMP, capacitor 2.500dia clip	1
41	CT1	179 494	TRANSFORMER, current sensing	1
42	R2	165 599	RESISTOR, WW adj 225W 0-6 ohm	1
	RC4	116 045	CONNECTOR & PINS	1
	PLG6	136 810	CONNECTOR & PINS	1
	PLG4		CONNECTOR, (see engine parts list)	1
	RC6	168 844	CONNECTOR, rect 4 pin/skt rcpt	1
43		134 792	LABEL, warning general precautionary	1

+When ordering a component originally displaying a precautionary label, the label should also be ordered.

◆ Part of Optional 043 051 Stainless Steel kit.

\*Recommended Spare Parts.

BE SURE TO PROVIDE MODEL AND SERIAL NUMBER WHEN ORDERING REPLACEMENT PARTS.



Item No.	Dia. Mkgs.	Part No.	Description	Quantity
----------	------------	----------	-------------	----------

**Figure 8-2. Panel, Front w/Components (Fig 8-1 Item 44)**

1	S1	162 671	SWITCH, polarity 5 position	1
2			NAMEPLATE, (order by model and serial number)	1
3		165 602	PANEL, front	1
4	S3	165 487	SWITCH, selector 4 position	1
5	R1	117 243	RHEOSTAT, WW 100W 10 ohm	1
6	PC1	142 724	MODULE, pull to idle 5 pin	1
7	S2	176 606	SWITCH, ignition 4 position w/out handle	1
8	GFCI2,3	147 939	RECEPTACLE, str dx grd 2P3W 15A 125V	2
9	CB1,2	117 501	CIRCUIT BREAKER, man reset 1P 40A 250VAC	2
10	CB3,4	093 996	CIRCUIT BREAKER, man reset 1P 20A 250VAC	2
11	HM	145 247	METER, hour 12-24VDC	1
12		175 010	CONTROL, push/pull	1
13		119 014	LEVER, switch	1
14	R3,VR1	046 819	SUPPRESSOR	1
15	Work, Elect	099 255	TERMINAL, pwr output neutral	2
16	RC1	164 704	RECEPTACLE, str 3P4W 50A 125/250V	1
17		083 030	STUD, brs .250-20 x 1.750	1
18		010 915	WASHER, flat .250 ID brs	3
19		601 836	NUT, .250-20 brs	3
20		159 921	BEZEL	1
21		147 195	NUT, .375-27 nyl	4
22		148 956	HANDLE, switch	2
23		097 924	KNOB, pointer	1

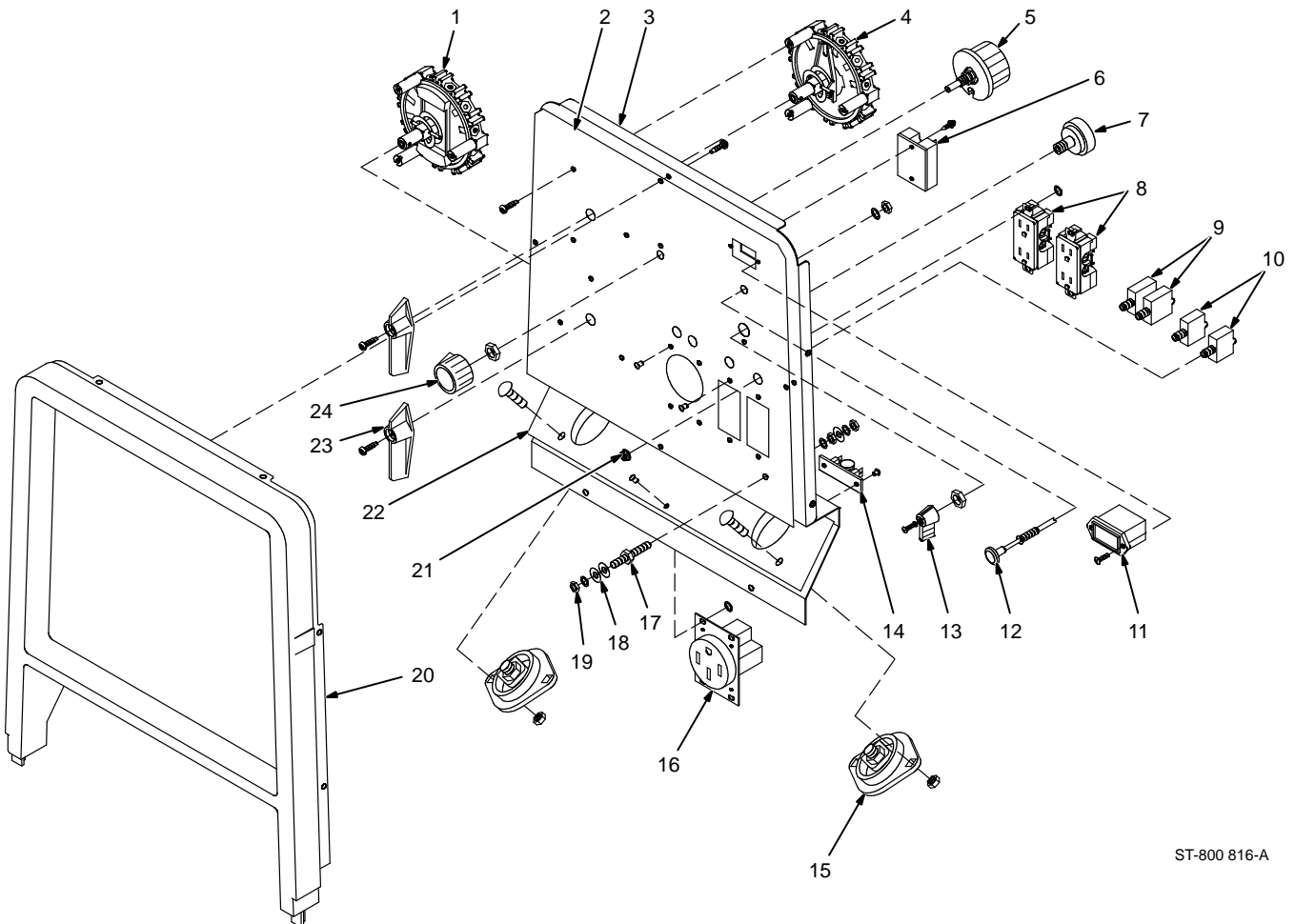

ST-800 816-A

**Figure 8-2. Panel, Front w/Components**

BE SURE TO PROVIDE MODEL AND SERIAL NUMBER WHEN ORDERING REPLACEMENT PARTS.

Item No.	Part No.	Description	Quantity
----------	----------	-------------	----------

**Figure 8-3. Generator (Fig 8-1 Item 21)**

...	1	013 367	.. LABEL, warning moving parts can cause serious injury .....	1
...	2	165 818	.. LABEL, warning engine fuel can cause fire .....	1
...	3	+179 500	.. STATOR, generator .....	1
...	4	159 909	.. ROTOR, generator (consisting of) .....	1
...	5	053 390	... BEARING, ball rdl sgl row 1.370 x 2.830 x .6 .....	1
...	6	160 566	... FAN, rotor .....	1
...	7	172 683	.. ADAPTER, engine .....	1
...	8	142 156	.. SCREW, .375-16 x 1.750hexhd .....	4
...	9	160 573	.. STUD, stl .375-16 x 17.125 .....	4
...	10	125 548	.. HOLDER, brush elect .....	1
...	11	005 614	.. HOLDER, brush .....	2
...	12	*126 984	.. BRUSH w/SPRING .....	2
...	13	161 306	.. CAP, brushholder .....	2
...	14	047 879	.. BAR, retaining brushholder .....	1
...	15	010 910	.. WASHER, flat .406 ID stl .....	4
...	16	010 909	.. NUT, .375-16 stl .....	4
...	17	160 943	.. ENDBELL, (consisting of) .....	1
...	18	143 220	... O-RING, 2.859 ID x .139CS .....	1

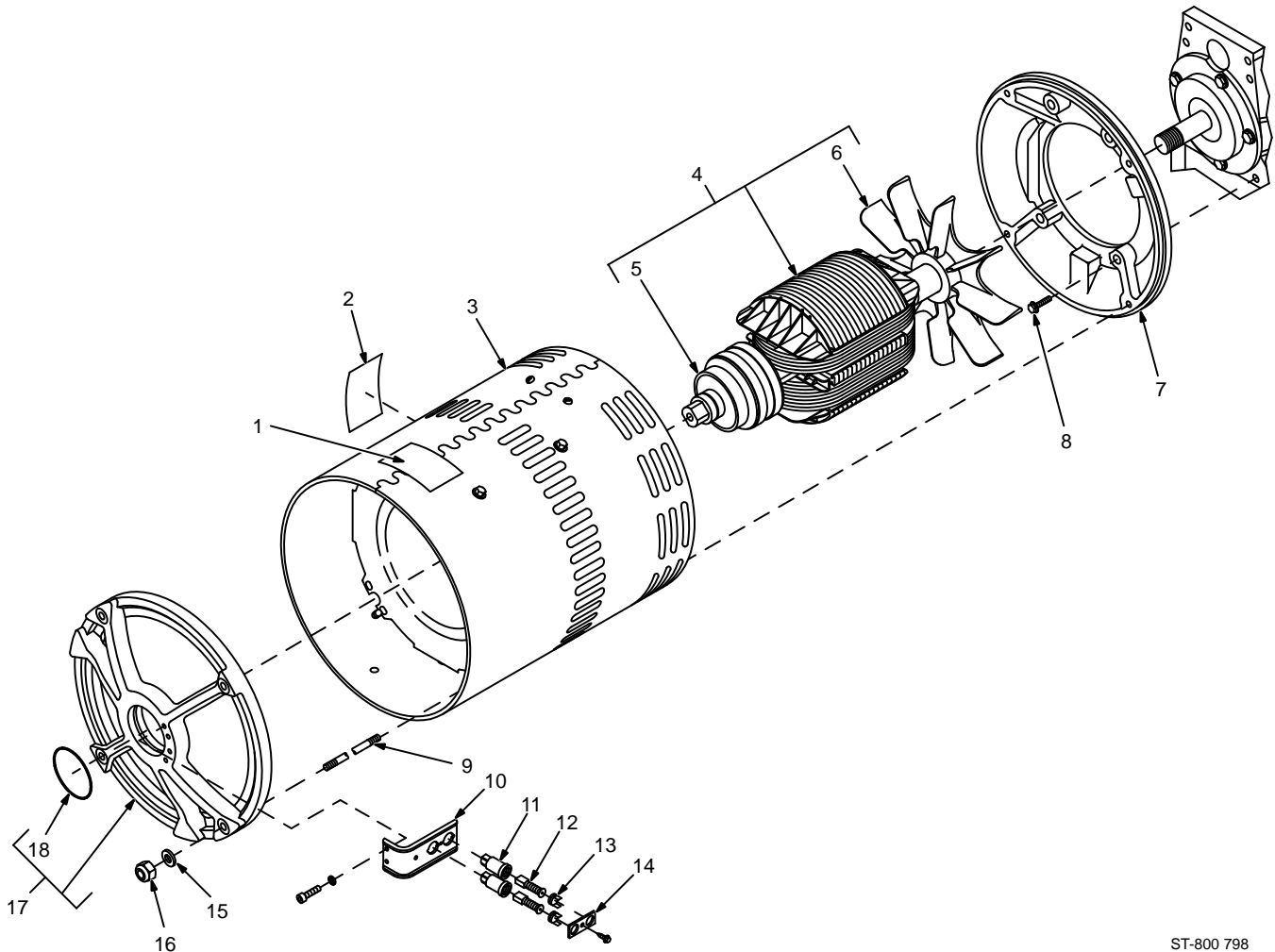

ST-800 798

**Figure 8-3. Generator**

+When ordering a component originally displaying a precautionary label, the label should also be ordered.

\*Recommended Spare Parts.

BE SURE TO PROVIDE MODEL AND SERIAL NUMBER WHEN ORDERING REPLACEMENT PARTS.

## Free Manuals Download Website

<http://myh66.com>

<http://usermanuals.us>

<http://www.somanuals.com>

<http://www.4manuals.cc>

<http://www.manual-lib.com>

<http://www.404manual.com>

<http://www.luxmanual.com>

<http://aubethermostatmanual.com>

Golf course search by state

<http://golfingnear.com>

Email search by domain

<http://emailbydomain.com>

Auto manuals search

<http://auto.somanuals.com>

TV manuals search

<http://tv.somanuals.com>