



**Miller**®

OM-867

083 696D

December 1993

# OWNER'S MANUAL

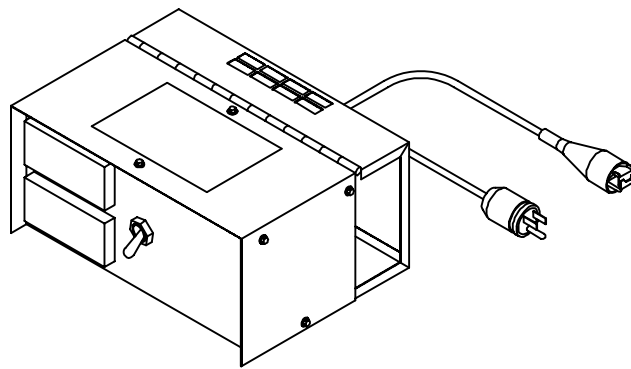

## Digi-Meter 1500 RMS (AC/DC)

- Digital Ammeter/Voltmeter For Measuring Weld Output
- Accurately ( $\pm 1\%$ ) Measures DC Or AC (RMS) Output
- Max. Capacity: 1500 Amperes, 100 Volts AC/DC At 100% Duty Cycle
- Includes 8 ft (2.4 m) 115 Volts AC Input Power Cord
- Displays To Nearest Ampere And 1/10 Volt
- Has Hold Feature Which Takes Readings After 10 Seconds Of Welding And Holds Displays For 15 Seconds After Welding Stops

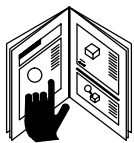

- Read and follow these instructions and all safety blocks carefully.
- Have only trained and qualified persons install, operate, or service this unit.
- Call your distributor if you do not understand the directions.

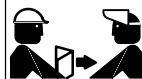

- Give this manual to the operator.



- For help, call your distributor
- or: MILLER Electric Mfg. Co., P.O. Box 1079, Appleton, WI 54912 414-734-9821

# From Miller to You

*Thank you and congratulations* on choosing Miller. Now you can get the job done and get it done right. We know you don't have time to do it any other way.

That's why when Niels Miller first started building arc welders in 1929, he made sure his products offered long-lasting value and superior quality. Like you, his customers couldn't afford anything less. Miller products had to be more than the best they could be. They had to be the best you could buy.



Today, the people that build and sell Miller products continue the tradition. They're just as committed to providing equipment and service that meets the high standards of quality and value established in 1929.

This Owner's Manual is designed to help you get the most out of your Miller products. Please take time to read the Safety precautions. They will help you protect yourself against potential hazards on the worksite. We've



Miller is the first welding equipment manufacturer in the U.S.A. to be registered to the ISO 9001 Quality System Standard.

made installation and operation quick and easy. With Miller you can count on years of reliable service with proper maintenance. And if for some reason the unit needs repair, there's a Troubleshooting section that will help you figure out what the problem is. The parts list will then help you to decide which exact part you may need to fix the problem. Warranty and service information for your particular model are also provided.

Miller Electric manufactures a full line of welders and welding related equipment. For information on other quality Miller products, contact your local Miller distributor to receive the latest full line catalog or individual catalog sheets. **To locate your nearest distributor or service agency call 1-800-4-A-Miller, or visit us at [www.MillerWelds.com](http://www.MillerWelds.com) on the web.**



Working as hard as you do – every power source from Miller is backed by the most hassle-free warranty in the business.

*Miller offers a Technical Manual which provides more detailed service and parts information for your unit. To obtain a Technical Manual, contact your local distributor. Your distributor can also supply you with Welding Process Manuals such as SMAW, GTAW, GMAW, and GMAW-P.*



# ARC WELDING SAFETY PRECAUTIONS



## WARNING

ARC WELDING can be hazardous.

**PROTECT YOURSELF AND OTHERS FROM POSSIBLE SERIOUS INJURY OR DEATH. KEEP CHILDREN AWAY. PACEMAKER WEARERS KEEP AWAY UNTIL CONSULTING YOUR DOCTOR.**

In welding, as in most jobs, exposure to certain hazards occurs. Welding is safe when precautions are taken. The safety information given below is only a summary of the more complete safety information that will be found in the Safety Standards listed on the next page. Read and follow all Safety Standards.

**HAVE ALL INSTALLATION, OPERATION, MAINTENANCE, AND REPAIR WORK PERFORMED ONLY BY QUALIFIED PEOPLE.**



### ELECTRIC SHOCK can kill.

Touching live electrical parts can cause fatal shocks or severe burns. The electrode and work circuit is electrically live whenever the output is on. The input power circuit and machine internal circuits are also live when power is on. In semiautomatic or automatic wire welding, the wire, wire reel, drive roll housing, and all metal parts touching the welding wire are electrically live. Incorrectly installed or improperly grounded equipment is a hazard.

1. Do not touch live electrical parts.
2. Wear dry, hole-free insulating gloves and body protection.
3. Insulate yourself from work and ground using dry insulating mats or covers big enough to prevent any physical contact with the work or ground.
4. Disconnect input power or stop engine before installing or servicing this equipment. Lockout/tagout input power according to OSHA 29 CFR 1910.147 (see Safety Standards).
5. Properly install and ground this equipment according to its Owner's Manual and national, state, and local codes.
6. Always verify the supply ground – check and be sure that input power cord ground wire is properly connected to ground terminal

in disconnect box or that cord plug is connected to a properly grounded receptacle outlet.

7. When making input connections, attach proper grounding conductor first – double-check connections.
8. Frequently inspect input power cord for damage or bare wiring – replace cord immediately if damaged – bare wiring can kill.
9. Turn off all equipment when not in use.
10. Do not use worn, damaged, undersized, or poorly spliced cables.
11. Do not drape cables over your body.
12. If earth grounding of the workpiece is required, ground it directly with a separate cable – do not use work clamp or work cable.
13. Do not touch electrode if you are in contact with the work, ground, or another electrode from a different machine.
14. Use only well-maintained equipment. Repair or replace damaged parts at once. Maintain unit according to manual.
15. Wear a safety harness if working above floor level.
16. Keep all panels and covers securely in place.
17. Clamp work cable with good metal-to-metal contact to workpiece or worktable as near the weld as practical.



### ARC RAYS can burn eyes and skin; NOISE can damage hearing; FLYING SLAG OR SPARKS can injure eyes.

Arc rays from the welding process produce intense visible and invisible (ultraviolet and infrared) rays that can burn eyes and skin. Noise from some processes can damage hearing. Chipping, grinding, and welds cooling throw off pieces of metal or slag.

#### NOISE

1. Use approved ear plugs or ear muffs if noise level is high.

#### ARC RAYS

2. Wear a welding helmet fitted with a proper shade of filter to protect your face and eyes when welding or watching (see ANSI Z49.1 and Z87.1 listed in Safety Standards).
3. Wear approved safety glasses with side shields.
4. Use protective screens or barriers to protect others from flash and glare; warn others not to watch the arc.
5. Wear protective clothing made from durable, flame-resistant material (wool and leather) and foot protection.



### FUMES AND GASES can be hazardous to your health.

Welding produces fumes and gases. Breathing these fumes and gases can be hazardous to your health.

1. Keep your head out of the fumes. Do not breathe the fumes.
2. If inside, ventilate the area and/or use exhaust at the arc to remove welding fumes and gases.
3. If ventilation is poor, use an approved air-supplied respirator.
4. Read the Material Safety Data Sheets (MSDSs) and the manufacturer's instruction for metals, consumables, coatings, cleaners, and degreasers.

5. Work in a confined space only if it is well ventilated, or while wearing an air-supplied respirator. Always have a trained watchperson nearby. Welding fumes and gases can displace air and lower the oxygen level causing injury or death. Be sure the breathing air is safe.
6. Do not weld in locations near degreasing, cleaning, or spraying operations. The heat and rays of the arc can react with vapors to form highly toxic and irritating gases.
7. Do not weld on coated metals, such as galvanized, lead, or cadmium plated steel, unless the coating is removed from the weld area, the area is well ventilated, and if necessary, while wearing an air-supplied respirator. The coatings and any metals containing these elements can give off toxic fumes if welded.

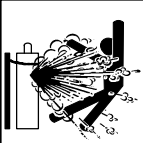

### CYLINDERS can explode if damaged.

Shielding gas cylinders contain gas under high pressure. If damaged, a cylinder can explode. Since gas cylinders are normally part of the welding process, be sure to treat them carefully.

1. Protect compressed gas cylinders from excessive heat, mechanical shocks, slag, open flames, sparks, and arcs.
2. Install cylinders in an upright position by securing to a stationary support or cylinder rack to prevent falling or tipping.
3. Keep cylinders away from any welding or other electrical circuits.

4. Never drape a welding torch over a gas cylinder.
5. Never allow a welding electrode to touch any cylinder.
6. Never weld on a pressurized cylinder – explosion will result.
7. Use only correct shielding gas cylinders, regulators, hoses, and fittings designed for the specific application; maintain them and associated parts in good condition.
8. Turn face away from valve outlet when opening cylinder valve.
9. Keep protective cap in place over valve except when cylinder is in use or connected for use.
10. Read and follow instructions on compressed gas cylinders, associated equipment, and CGA publication P-1 listed in Safety Standards.

	<p><b>WELDING can cause fire or explosion.</b></p> <p>Welding on closed containers, such as tanks, drums, or pipes, can cause them to blow up. Sparks can fly off from the welding arc. The flying sparks, hot workpiece, and hot equipment can cause fires and burns. Accidental contact of electrode to metal objects can cause sparks, explosion, overheating, or fire. Check and be sure the area is safe before doing any welding.</p> <ol style="list-style-type: none"> <li>1. Protect yourself and others from flying sparks and hot metal.</li> <li>2. Do not weld where flying sparks can strike flammable material.</li> <li>3. Remove all flammables within 35 ft (10.7 m) of the welding arc. If this is not possible, tightly cover them with approved covers.</li> <li>4. Be alert that welding sparks and hot materials from welding can easily go through small cracks and openings to adjacent areas.</li> <li>5. Watch for fire, and keep a fire extinguisher nearby.</li> </ol>	<ol style="list-style-type: none"> <li>6. Be aware that welding on a ceiling, floor, bulkhead, or partition can cause fire on the hidden side.</li> <li>7. Do not weld on closed containers such as tanks, drums, or pipes, unless they are properly prepared according to AWS F4.1 (see Safety Standards).</li> <li>8. Connect work cable to the work as close to the welding area as practical to prevent welding current from traveling long, possibly unknown paths and causing electric shock and fire hazards.</li> <li>9. Do not use welder to thaw frozen pipes.</li> <li>10. Remove stick electrode from holder or cut off welding wire at contact tip when not in use.</li> <li>11. Wear oil-free protective garments such as leather gloves, heavy shirt, cuffless trousers, high shoes, and a cap.</li> <li>12. Remove any combustibles, such as a butane lighter or matches, from your person before doing any welding.</li> </ol>
--	---	---

 <h2 style="margin: 0;">WARNING</h2>	<h3 style="margin: 0;">ENGINES can be hazardous.</h3>
---	---

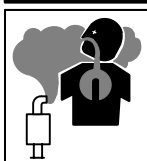
	<p><b>ENGINE EXHAUST GASES can kill.</b></p> <p>Engines produce harmful exhaust gases.</p>	<ol style="list-style-type: none"> <li>1. Use equipment outside in open, well-ventilated areas.</li> <li>2. If used in a closed area, vent engine exhaust outside and away from any building air intakes.</li> </ol>
---	--	--

	<p><b>ENGINE FUEL can cause fire or explosion.</b></p> <p>Engine fuel is highly flammable.</p> <ol style="list-style-type: none"> <li>1. Stop engine and let it cool off before checking or adding fuel.</li> <li>2. Do not add fuel while smoking or if unit is near any sparks or open flames.</li> </ol>	<ol style="list-style-type: none"> <li>3. Do not overfill tank – allow room for fuel to expand.</li> <li>4. Do not spill fuel. If fuel is spilled, clean up before starting engine.</li> </ol>
---	---	--

	<p><b>MOVING PARTS can cause injury.</b></p> <p>Moving parts, such as fans, rotors, and belts can cut fingers and hands and catch loose clothing.</p> <ol style="list-style-type: none"> <li>1. Keep all doors, panels, covers, and guards closed and securely in place.</li> <li>2. Stop engine before installing or connecting unit.</li> </ol>	<ol style="list-style-type: none"> <li>3. Have only qualified people remove guards or covers for maintenance and troubleshooting as necessary.</li> <li>4. To prevent accidental starting during servicing, disconnect negative (-) battery cable from battery.</li> <li>5. Keep hands, hair, loose clothing, and tools away from moving parts.</li> <li>6. Reinstall panels or guards and close doors when servicing is finished and before starting engine.</li> </ol>
--	---	--

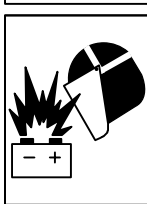
	<p><b>SPARKS can cause BATTERY GASES TO EXPLODE; BATTERY ACID can burn eyes and skin.</b></p> <p>Batteries contain acid and generate explosive gases.</p>	<ol style="list-style-type: none"> <li>1. Always wear a face shield when working on a battery.</li> <li>2. Stop engine before disconnecting or connecting battery cables.</li> <li>3. Do not allow tools to cause sparks when working on a battery.</li> <li>4. Do not use welder to charge batteries or jump start vehicles.</li> <li>5. Observe correct polarity (+ and -) on batteries.</li> </ol>
---	---	---

	<p><b>STEAM AND PRESSURIZED HOT COOLANT can burn face, eyes, and skin.</b></p> <p>It is best to check coolant level when engine is cold to avoid scalding.</p>	<ol style="list-style-type: none"> <li>1. If the engine is warm and checking is needed, follow steps 2 and 3.</li> <li>2. Wear safety glasses and gloves and put a rag over cap.</li> <li>3. Turn cap slightly and let pressure escape slowly before completely removing cap.</li> </ol>
---	--	--

## PRINCIPAL SAFETY STANDARDS

*Safety in Welding and Cutting*, ANSI Standard Z49.1, from American Welding Society, 550 N.W. LeJeune Rd, Miami FL 33126

*Safety and Health Standards*, OSHA 29 CFR 1910, from Superintendent of Documents, U.S. Government Printing Office, Washington, D.C. 20402.

*Recommended Safe Practices for the Preparation for Welding and Cutting of Containers That Have Held Hazardous Substances*, American Welding Society Standard AWS F4.1, from American Welding Society, 550 N.W. LeJeune Rd, Miami, FL 33126

*National Electrical Code*, NFPA Standard 70, from National Fire Protection Association, Batterymarch Park, Quincy, MA 02269.

*Safe Handling of Compressed Gases in Cylinders*, CGA Pamphlet P-1, from Compressed Gas Association, 1235 Jefferson Davis Highway, Suite 501, Arlington, VA 22202.

*Code for Safety in Welding and Cutting*, CSA Standard W117.2, from Canadian Standards Association, Standards Sales, 178 Rexdale Boulevard, Rexdale, Ontario, Canada M9W 1R3.

*Safe Practices For Occupation And Educational Eye And Face Protection*, ANSI Standard Z87.1, from American National Standards Institute, 1430 Broadway, New York, NY 10018.

*Cutting And Welding Processes*, NFPA Standard 51B, from National Fire Protection Association, Batterymarch Park, Quincy, MA 02269.

# EMF INFORMATION

## NOTE



### *Considerations About Welding And The Effects Of Low Frequency Electric And Magnetic Fields*

The following is a quotation from the General Conclusions Section of the U.S. Congress, Office of Technology Assessment, *Biological Effects of Power Frequency Electric & Magnetic Fields – Background Paper*, OTA-BP-E-53 (Washington, DC: U.S. Government Printing Office, May 1989): “. . . there is now a very large volume of scientific findings based on experiments at the cellular level and from studies with animals and people which clearly establish that low frequency magnetic fields can interact with, and produce changes in, biological systems. While most of this work is of very high quality, the results are complex. Current scientific understanding does not yet allow us to interpret the evidence in a single coherent framework. Even more frustrating, it does not yet allow us to draw definite conclusions about questions of possible risk or to offer clear science-based advice on strategies to minimize or avoid potential risks.”

To reduce magnetic fields in the workplace, use the following procedures:

1. Keep cables close together by twisting or taping them.
2. Arrange cables to one side and away from the operator.
3. Do not coil or drape cables around the body.
4. Keep welding power source and cables as far away as practical.
5. Connect work clamp to workpiece as close to the weld as possible.

#### **About Pacemakers:**

The above procedures are among those also normally recommended for pacemaker wearers. Consult your doctor for complete information.

mod10.1 4/93

## TABLE OF CONTENTS

<b>SECTION 1 – SAFETY INFORMATION</b> .....	1
<b>SECTION 2 – SPECIFICATIONS</b> .....	1
<b>SECTION 3 – INSTALLATION</b>	
3-1. Location .....	2
3-2. Connection Diagram .....	3
<b>SECTION 4 – OPERATION</b> .....	4
<b>SECTION 5 – MAINTENANCE &amp; TROUBLESHOOTING</b>	
5-1. Routine Maintenance .....	5
5-2. Troubleshooting .....	5
<b>SECTION 6 – ELECTRICAL DIAGRAMS</b> .....	6
<b>SECTION 7 – PARTS LIST</b>	
Figure 7-1. Complete Assembly .....	8



# SECTION 1 – SAFETY INFORMATION

mod1.1 2/93

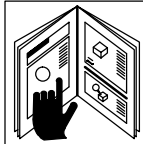

- Read all safety messages throughout this manual.
- Obey all safety messages to avoid injury.
- Learn the meaning of WARNING and CAUTION.

1 → **WARNING**

2 → **ELECTRIC SHOCK can kill.**

3 → Do not touch live electrical parts.  
Disconnect input power before installing or servicing.

4 →

5 →

2 → **CAUTION**

**MOVING PARTS can injure.**

• Keep away from moving parts.  
• Keep all panels and covers closed when operating.

6 → **WARNING** **READ SAFETY BLOCKS at start of Section 3-1 before proceeding.**

7 → **NOTE** *Turn Off switch when using high frequency.*

1 Safety Alert Symbol

2 Signal Word

WARNING means possible death or serious injury can happen.

CAUTION means possible minor injury or equipment damage can happen.

3 Statement Of Hazard And Result

4 Safety Instructions To Avoid Hazard

5 Hazard Symbol (If Available)

6 Safety Banner

Read safety blocks for each symbol shown.

7 NOTE

Special instructions for best operation – not related to safety.



Figure 1-1. Safety Information

# SECTION 2 – SPECIFICATIONS

Table 2-1. Meter Specifications

Specification	Description
Type Of Input Power	115 Volts AC, 50/60 Hz
Input Power Cord With Plug	8 ft (2.4 m)
Voltage Sensing Cord With Clamp	21 ft (6.4 m)
Overall Dimensions	See Figure 3-1
Weight	Net: 13.5 lb (6.1 kg); Ship: 15 lb (7 kg)
Max. Capacity At 100% Duty Cycle	1500 Amps At 100 Volts AC/DC

# SECTION 3 – INSTALLATION

 <b>WARNING</b>	
	<p><b>ELECTRIC SHOCK can kill.</b></p> <ul style="list-style-type: none"> <li>Do not touch live electrical parts.</li> <li>Turn Off welding power source and disconnect input power before inspecting or installing. Stop engine on welding generator.</li> </ul>
	<p><b>FUMES can be hazardous; LACK OF FRESH AIR AND PROPER VENTILATION can be harmful.</b></p> <ul style="list-style-type: none"> <li>Do not breathe welding fumes.</li> <li>Place unit only where there is a good fresh air supply and proper ventilation.</li> </ul>
<small>swarn11.1* 3/93</small>	

## 3-1. Location

	Inches	Millimeters
A	6	152
B	11-5/8	295
C	8-3/8	213

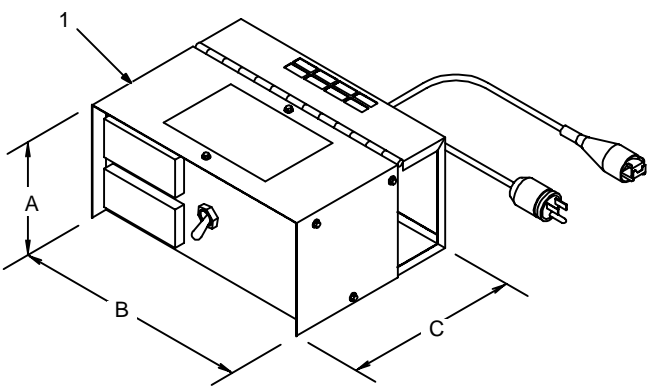

Turn Off welding power source.  
1 Meter

Place meter on bench, welding power source, or other convenient location.

ST-084 121-A

**Figure 3-1. Overall Dimensions**



### 3-2. Connection Diagram

**WARNING**



**READ SAFETY BLOCKS at start of Section 3 before proceeding.**

 Using meter in applications where high-frequency output is used may cause poor arc starting and unreliable meter readings.

- 1 Welding Power Source
- 2 Weld Cable (Customer Supplied)

See power source Owner's Manual for proper size cable. Keep cable length between meter and arc as short as possible for more accurate readings.

- 3 Meter
- 4 Access Door
- 5 Shunt Terminal
- 6 SMAW Electrode Holder
- 7 GTAW Torch
- 8 Wire Feeder

Open access door and connect weld cable from power source to either shunt terminal. Connect weld cable from electrode holder, torch or wire feeder to other shunt terminal.

Close access door.

- 9 115 VAC Cord/Plug
- 10 115 VAC Grounded Receptacle

Connect input power plug to welding power source or other 115 VAC receptacle.

- 11 Voltage Sensing Cord/Clamp
- 12 Workpiece

Connect voltage sensing clamp to workpiece.

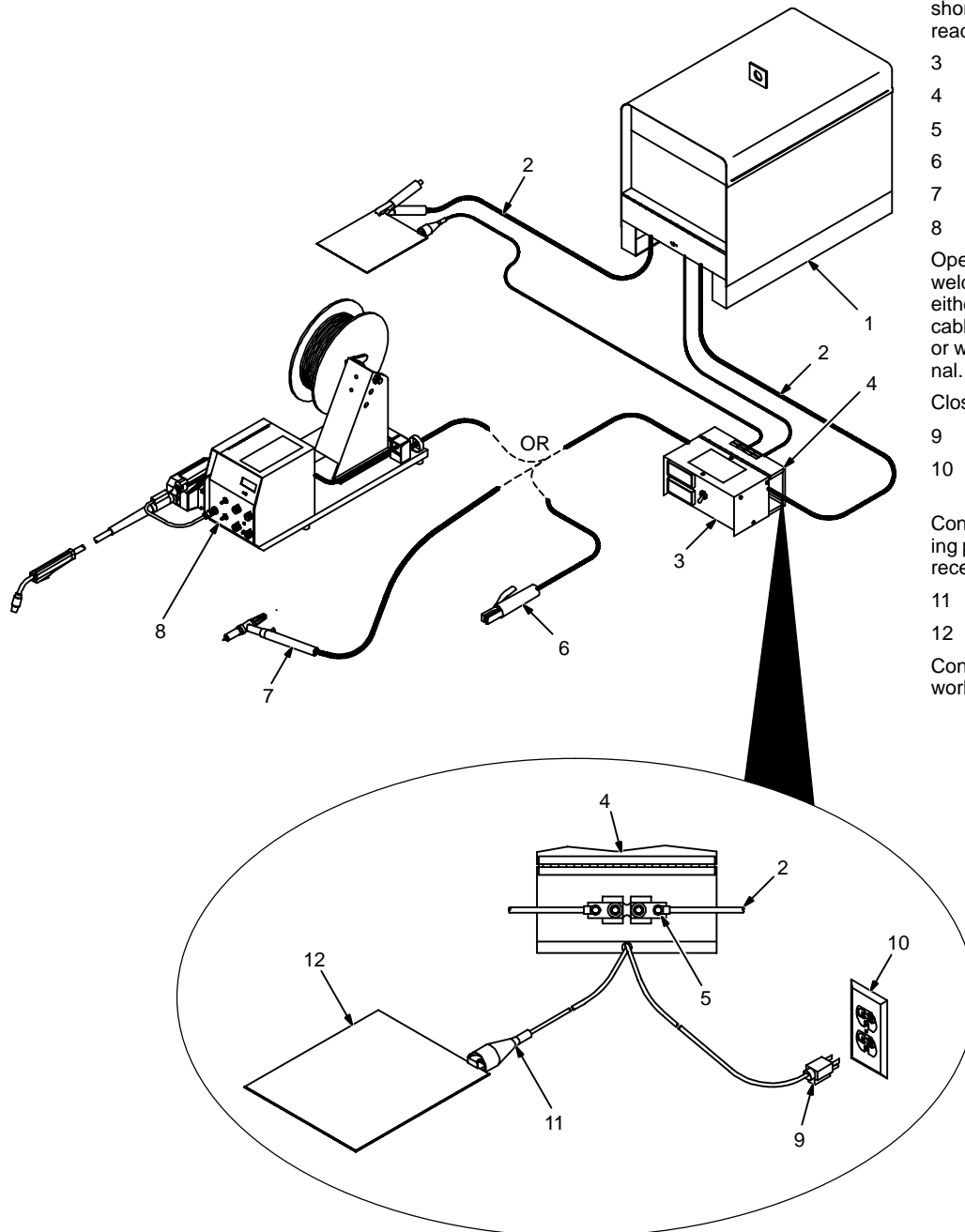

ST-154 610-B / ST-155 327

**Figure 3-2. Connection Diagram**

# SECTION 4 – OPERATION

<b>WARNING</b>			
	<p><b>ELECTRIC SHOCK can kill.</b></p> <ul style="list-style-type: none"> <li>Always wear dry insulating gloves.</li> <li>Insulate yourself from work and ground.</li> <li>Do not touch live electrical parts.</li> <li>Keep all panels and covers securely in place.</li> </ul>		<p><b>ARC RAYS can burn eyes and skin; NOISE can damage hearing.</b></p> <ul style="list-style-type: none"> <li>Wear welding helmet with correct shade of filter.</li> <li>Wear correct eye, ear, and body protection.</li> </ul>
	<p><b>FUMES AND GASES can be hazardous to your health.</b></p> <ul style="list-style-type: none"> <li>Keep your head out of the fumes.</li> <li>Ventilate area, or use breathing device.</li> <li>Read Material Safety Data Sheets (MSDSs) and manufacturer's instructions for material used.</li> </ul>		<p><b>MOVING PARTS can cause injury.</b></p> <ul style="list-style-type: none"> <li>Keep away from moving parts.</li> <li>Keep all doors, panels, covers, and guards closed and securely in place.</li> </ul>
	<p><b>WELDING can cause fire or explosion.</b></p> <ul style="list-style-type: none"> <li>Do not weld near flammable material.</li> <li>Watch for fire; keep extinguisher nearby.</li> <li>Do not locate unit over combustible surfaces.</li> <li>Do not weld on closed containers.</li> <li>Allow work and equipment to cool before handling.</li> </ul>		<p><b>MAGNETIC FIELDS FROM HIGH CURRENTS can affect pacemaker operation.</b></p> <ul style="list-style-type: none"> <li>Pacemaker wearers keep away.</li> <li>Wearers should consult their doctor before going near arc welding, gouging, or spot welding operations.</li> </ul>
		<p>See Safety Precautions at beginning of manual for basic welding safety information. <span style="float: right;">swarn6.1 10/91</span></p>	

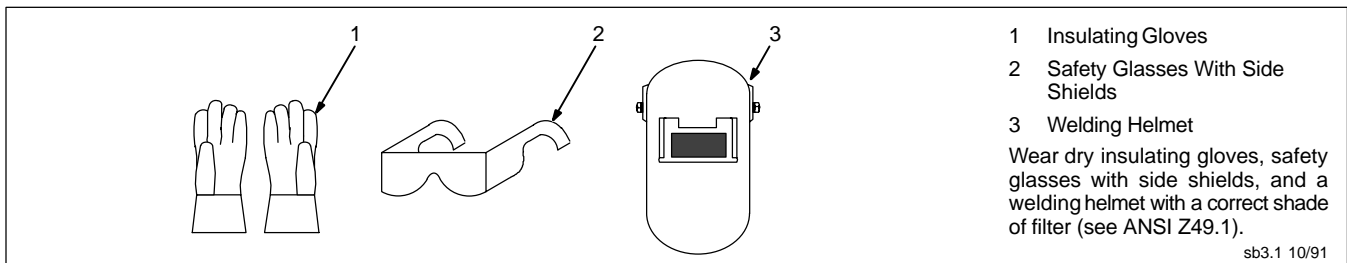

Figure 4-1. Safety Equipment

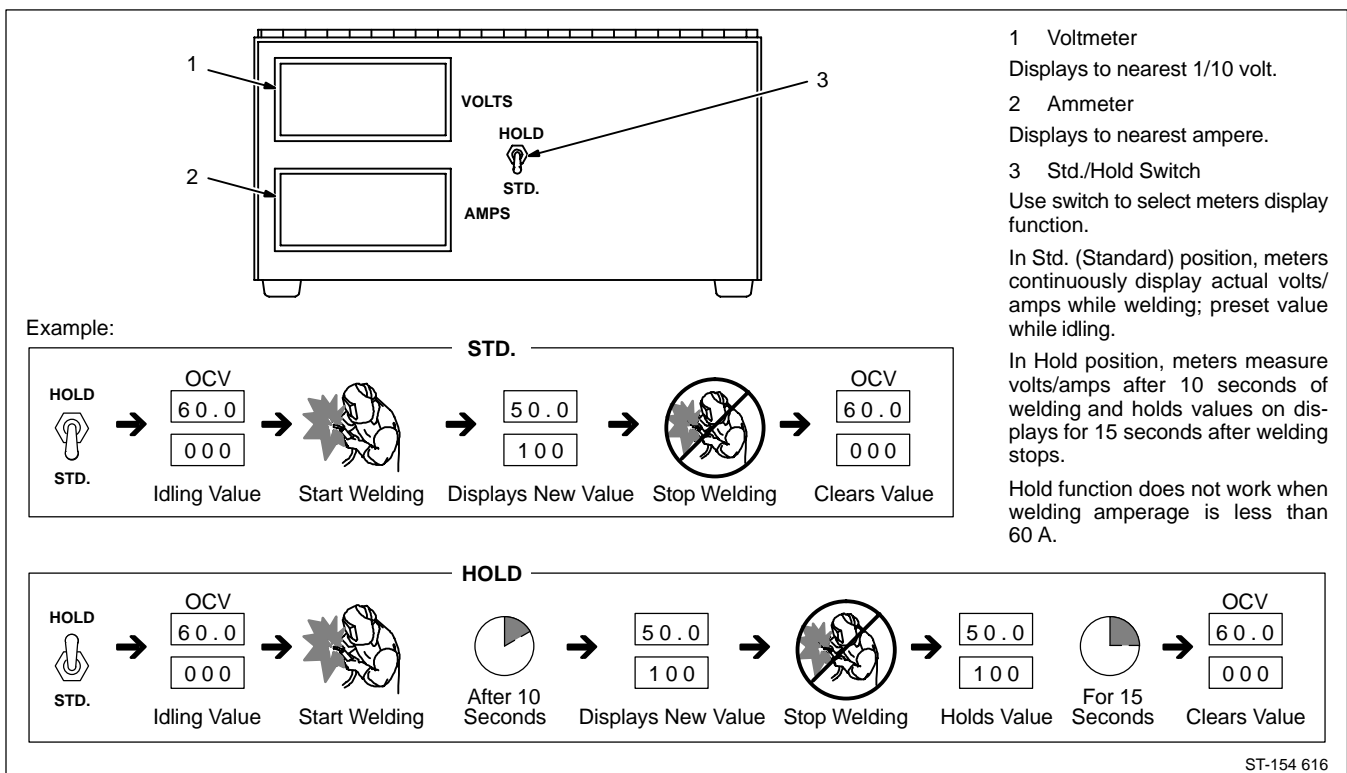



Figure 4-2. Voltmeter/Ammeter And Std./Hold Switch

# SECTION 5 – MAINTENANCE & TROUBLESHOOTING

<b>⚠ WARNING</b>	
	<p><b>ELECTRIC SHOCK can kill.</b></p> <ul style="list-style-type: none"> <li>Do not touch live electrical parts.</li> <li>Turn Off welding power source, and disconnect input power before inspecting, maintaining, or servicing. Stop engine on welding generator.</li> </ul>
	<p><b>HOT PARTS can cause severe burns.</b></p> <ul style="list-style-type: none"> <li>Allow cooling period before maintaining or servicing.</li> </ul> <p>Maintenance and troubleshooting to be performed only by qualified persons.</p>
swarn8.1* 10/91	

## 5-1. Routine Maintenance

**3 Months**

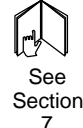

See Section 7



Replace Unreadable Labels



Tape Or Replace Cracked Weld Cable

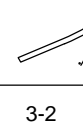

Clean And Tighten Weld Terminals

⚠ Turn Off all power before maintaining.

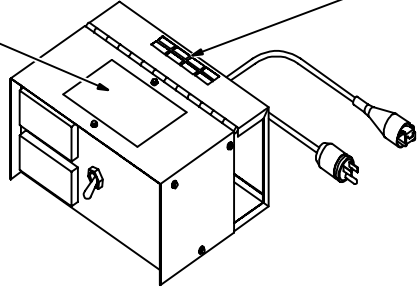

**6 Months**

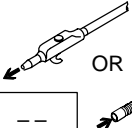

Blow Out Or Vacuum Inside

ST-084 121-A

Figure 5-1. Maintenance Schedule

## 5-2. Troubleshooting

<b>⚠ WARNING</b>	 	<b>READ SAFETY BLOCKS at start of Section 5 before proceeding.</b>
------------------	---	--

Table 5-1. Welding Trouble

Trouble	Remedy	Section
Unit completely inoperative; no meter display.	Be sure input power cord is plugged in and that receptacle is receiving input power.	3-2
Incorrect meter display.	Check weld cable, input power, and voltage sensing connections.	3-2
	Turn off high frequency, if applicable.	3-2
No display on one meter only; other meter works.	Check connections to meter module; tighten or clean if necessary.	--
	Check and replace meter module if necessary.	--
	Have Factory Authorized Service Station/Service Distributor check digital meter board PC1.	--
Erratic meter display.	Check connections to meter shunt; tighten or clean if necessary.	--
Meters do not hold display with Std./Hold switch in Hold position.	Place switch in Std. position when welding amperage is below required minimum.	Figure 4-2
	Have Factory Authorized Service Station/Service Distributor check digital meter board PC1.	--

# SECTION 6 – ELECTRICAL DIAGRAMS

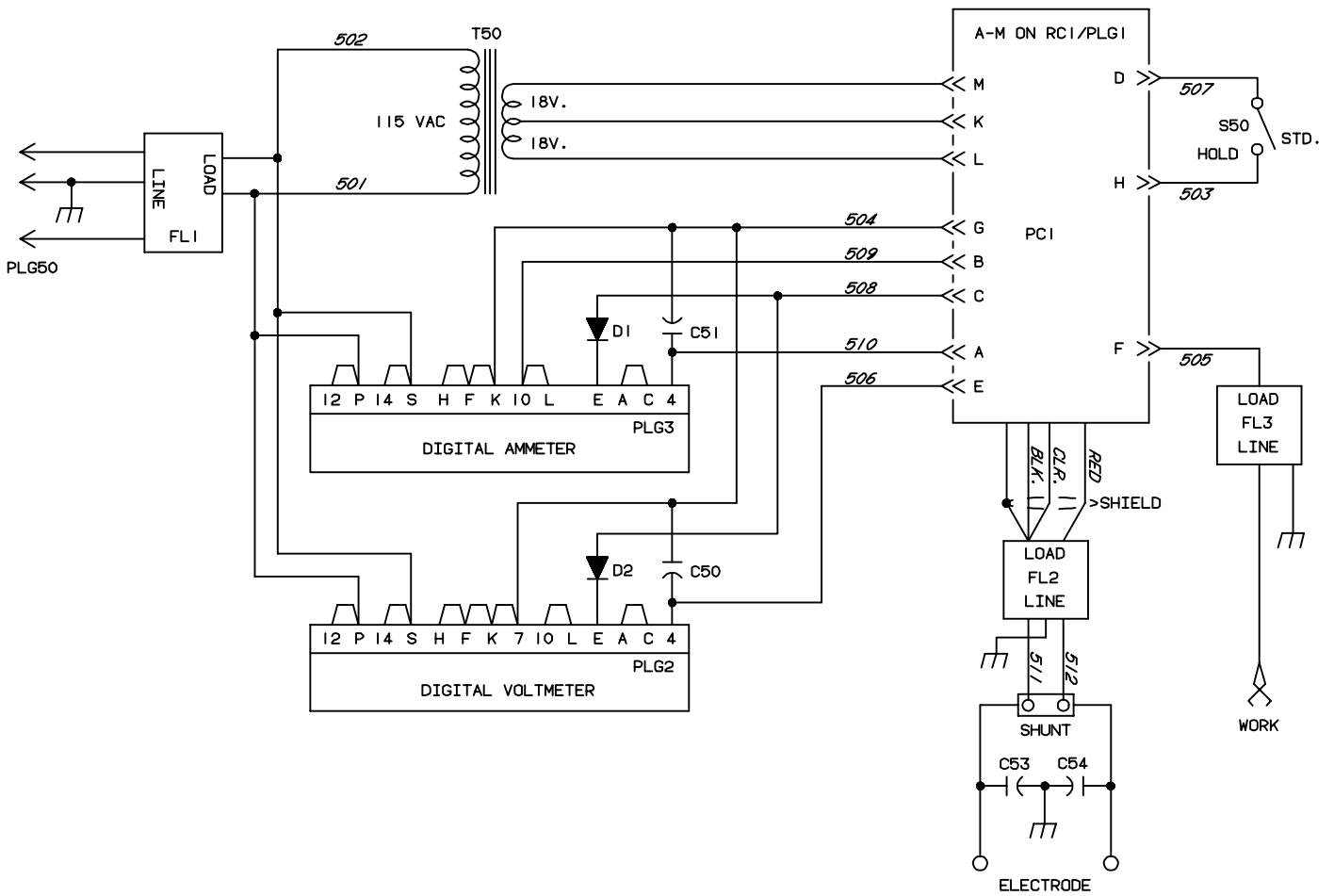

Figure 6-1. Circuit Diagram

SB-131 649

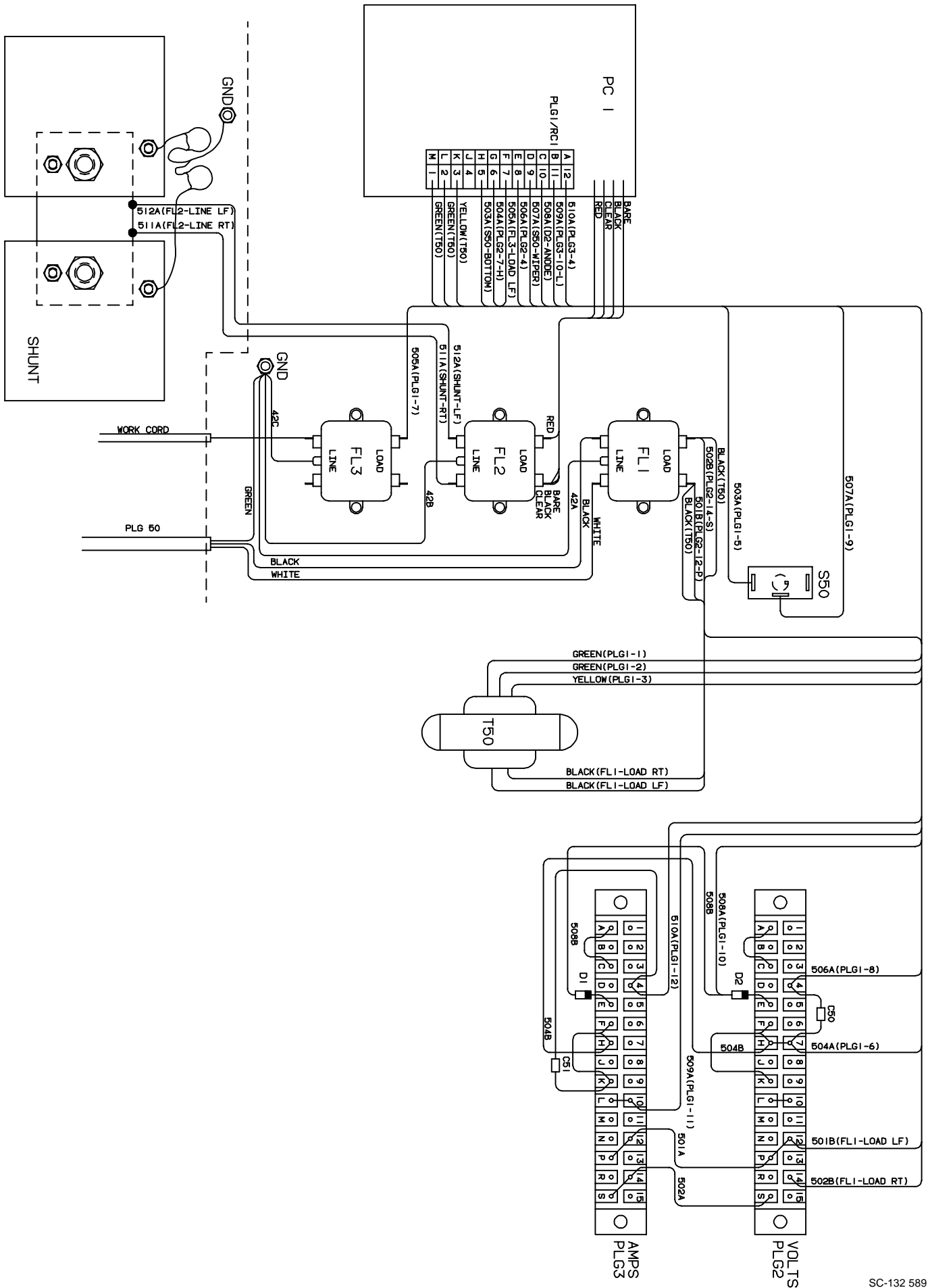
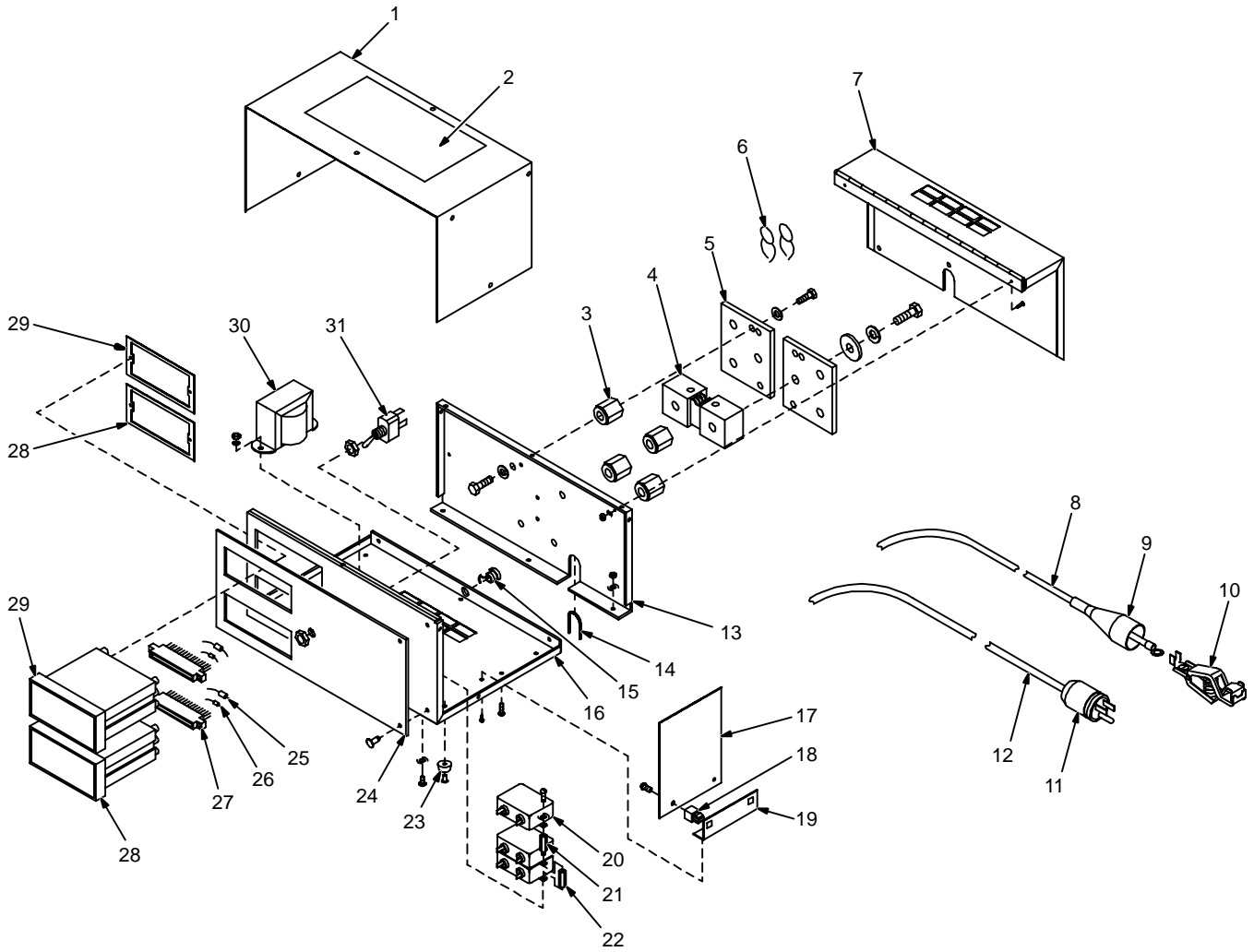

Figure 6-2. Wiring Diagram

# SECTION 7 – PARTS LIST



ST-083 851-D

Figure 7-1. Complete Assembly

Item No.	Dia. Mkgs.	Part No.	Description	Quantity
<b>Figure 7-1. Complete Assembly</b>				
1		+082 980	WRAPPER	1
2		134 327	LABEL, warning general precautionary	1
3		025 248	STAND-OFF, insul .250-20 x 1.250 lg x .437thk	4
4	Shunt	072 425	SHUNT, meter 50MV 1500A	1
5		083 082	BUS BAR, jumper	2
		604 126	SCREW, cap stl hexhd .500-13 x 1.000 (connecting cables to digimeter shunt)	2
		602 216	WASHER, lock stl split .500 (connecting cables to digimeter shunt)	2
		602 247	WASHER, flat stl SAE .500 (connecting cables to digimeter shunt)	2
		601 879	NUT, stl hex full .500-13 (connecting cables to digimeter shunt)	2
6	C53,54	143 461	CAPACITOR	2
7		082 983	WRAPPER, shunt	1
8		600 848	WIRE, lead mot 12ga strd	21ft
9		601 226	INSULATOR, vinyl clamp univ 25A	1
10		601 228	CLAMP, univ 25A	1
11	PLG50	073 690	PLUG, str grd armd 2P3W 15A 125V	1
12		604 825	CABLE, port No. 18 3/c (order by ft)	8ft
13		131 708	PANEL, rear	1
14		603 107	HOSE, nprn slit bk .156 ID x .343 OD (order by ft)	1ft
15		010 476	BUSHING, strain relief .625 ID x .570mtg hole	1
16		131 709	CASE SECTION, bottom/front	1
17	PC1	132 299	CIRCUIT CARD, digital meter AC/DC models	1
	PLG1	135 559	CONNECTOR & SOCKETS, (consisting of)	1
		079 747	CONNECTOR, rect skt 24-18ga Amp 350980-1	12
18		080 509	GROMMET, scr No. 8/10 panel hole .312sq .375 high	2
19		131 762	BRACKET, mtg PC card	1
20	FL1-3	084 171	FILTER, line pwr 115/250V 50-400Hz at 2A	3
21		132 124	STAND-OFF, 6-32 x 1.000 lg	2
22		094 484	STAND-OFF, 6-32 x 1.000 lg	2
23		019 663	MOUNT, nprn 15/16 OD	4
24			NAMEPLATE, (order by model and style number)	1
25	C50,51	122 723	CAPACITOR, cer mono .1uf 50VDC	2
26	D1,2	026 202	DIODE, rect 1A 400V SP	2
27	PLG2,3	028 598	CONNECTOR, edge 15skt plug Amp 582772-3	2
28	Amp	083 722	METER, digital 0 to 19.99V	1
29	Volt	081 798	METER, digital 0 to 19.99V LED 115VAC	1
30	T50	131 685	TRANSFORMER, control	1
31	S50	011 609	SWITCH, tgl SPDT 15A 125VAC	1

+When ordering a component originally displaying a precautionary label, the label should also be ordered.  
**BE SURE TO PROVIDE MODEL AND STYLE NUMBER WHEN ORDERING REPLACEMENT PARTS.**









# TRUE BLUE<sup>®</sup>

## WARRANTY

Effective January 1, 2000

(Equipment with a serial number preface of "LA" or newer)

This limited warranty supersedes all previous Miller warranties and is exclusive with no other guarantees or warranties expressed or implied.

### Warranty Questions?

Call  
1-800-4-A-MILLER  
for your local  
Miller distributor.

Your distributor also gives  
you ...

#### Service

You always get the fast,  
reliable response you  
need. Most replacement  
parts can be in your  
hands in 24 hours.

#### Support

Need fast answers to the  
tough welding questions?  
Contact your distributor.  
The expertise of the  
distributor and Miller is  
there to help you, every  
step of the way.

**LIMITED WARRANTY** – Subject to the terms and conditions below, Miller Electric Mfg. Co., Appleton, Wisconsin, warrants to its original retail purchaser that new Miller equipment sold after the effective date of this limited warranty is free of defects in material and workmanship at the time it is shipped by Miller. THIS WARRANTY IS EXPRESSLY IN LIEU OF ALL OTHER WARRANTIES, EXPRESS OR IMPLIED, INCLUDING THE WARRANTIES OF MERCHANTABILITY AND FITNESS.

Within the warranty periods listed below, Miller will repair or replace any warranted parts or components that fail due to such defects in material or workmanship. Miller must be notified in writing within thirty (30) days of such defect or failure, at which time Miller will provide instructions on the warranty claim procedures to be followed.

Miller shall honor warranty claims on warranted equipment listed below in the event of such a failure within the warranty time periods. All warranty time periods start on the date that the equipment was delivered to the original retail purchaser, or one year after the equipment is sent to a North American distributor or eighteen months after the equipment is sent to an International distributor.

1. 5 Years Parts – 3 Years Labor
  - \* Original main power rectifiers
  - \* Inverters (input and output rectifiers only)
2. 3 Years — Parts and Labor
  - \* Transformer/Rectifier Power Sources
  - \* Plasma Arc Cutting Power Sources
  - \* Semi-Automatic and Automatic Wire Feeders
  - \* Inverter Power Supplies
  - \* Intelligig
  - \* Engine Driven Welding Generators  
**(NOTE: Engines are warranted separately by the engine manufacturer.)**
3. 1 Year — Parts and Labor
  - \* DS-2 Wire Feeder
  - \* Motor Driven Guns (w/exception of Spoolmate 185 & Spoolmate 250)
  - \* Process Controllers
  - \* Positioners and Controllers
  - \* Automatic Motion Devices
  - \* RFCS Foot Controls
  - \* Induction Heating Power Sources
  - \* Water Coolant Systems
  - \* HF Units
  - \* Grids
  - \* Maxstar 140
  - \* Spot Welders
  - \* Load Banks
  - \* Miller Cyclomatic Equipment
  - \* Running Gear/Trailers
  - \* Plasma Cutting Torches (except APT & SAF Models)
  - \* Field Options  
**(NOTE: Field options are covered under True Blue<sup>®</sup> for the remaining warranty period of the product they are installed in, or for a minimum of one year — whichever is greater.)**
4. 6 Months — Batteries
5. 90 Days — Parts
  - \* MIG Guns/TIG Torches
  - \* Induction Heating Coils and Blankets

- \* APT, ZIPCUT & PLAZCUT Model Plasma Cutting Torches
- \* Remote Controls
- \* Accessory Kits
- \* Replacement Parts (No labor)
- \* Spoolmate 185 & Spoolmate 250
- \* Canvas Covers

Miller's True Blue<sup>®</sup> Limited Warranty shall not apply to:

1. **Consumable components; such as contact tips, cutting nozzles, contactors, brushes, slip rings, relays or parts that fail due to normal wear.**
2. Items furnished by Miller, but manufactured by others, such as engines or trade accessories. These items are covered by the manufacturer's warranty, if any.
3. Equipment that has been modified by any party other than Miller, or equipment that has been improperly installed, improperly operated or misused based upon industry standards, or equipment which has not had reasonable and necessary maintenance, or equipment which has been used for operation outside of the specifications for the equipment.

MILLER PRODUCTS ARE INTENDED FOR PURCHASE AND USE BY COMMERCIAL/INDUSTRIAL USERS AND PERSONS TRAINED AND EXPERIENCED IN THE USE AND MAINTENANCE OF WELDING EQUIPMENT.

In the event of a warranty claim covered by this warranty, the exclusive remedies shall be, at Miller's option: (1) repair; or (2) replacement; or, where authorized in writing by Miller in appropriate cases, (3) the reasonable cost of repair or replacement at an authorized Miller service station; or (4) payment of or credit for the purchase price (less reasonable depreciation based upon actual use) upon return of the goods at customer's risk and expense. Miller's option of repair or replacement will be F.O.B., Factory at Appleton, Wisconsin, or F.O.B. at a Miller authorized service facility as determined by Miller. Therefore no compensation or reimbursement for transportation costs of any kind will be allowed.

TO THE EXTENT PERMITTED BY LAW, THE REMEDIES PROVIDED HEREIN ARE THE SOLE AND EXCLUSIVE REMEDIES. IN NO EVENT SHALL MILLER BE LIABLE FOR DIRECT, INDIRECT, SPECIAL, INCIDENTAL OR CONSEQUENTIAL DAMAGES (INCLUDING LOSS OF PROFIT), WHETHER BASED ON CONTRACT, TORT OR ANY OTHER LEGAL THEORY.

ANY EXPRESS WARRANTY NOT PROVIDED HEREIN AND ANY IMPLIED WARRANTY, GUARANTY OR REPRESENTATION AS TO PERFORMANCE, AND ANY REMEDY FOR BREACH OF CONTRACT TORT OR ANY OTHER LEGAL THEORY WHICH, BUT FOR THIS PROVISION, MIGHT ARISE BY IMPLICATION, OPERATION OF LAW, CUSTOM OF TRADE OR COURSE OF DEALING, INCLUDING ANY IMPLIED WARRANTY OF MERCHANTABILITY OR FITNESS FOR PARTICULAR PURPOSE, WITH RESPECT TO ANY AND ALL EQUIPMENT FURNISHED BY MILLER IS EXCLUDED AND DISCLAIMED BY MILLER.

Some states in the U.S.A. do not allow limitations of how long an implied warranty lasts, or the exclusion of incidental, indirect, special or consequential damages, so the above limitation or exclusion may not apply to you. This warranty provides specific legal rights, and other rights may be available, but may vary from state to state.

In Canada, legislation in some provinces provides for certain additional warranties or remedies other than as stated herein, and to the extent that they may not be waived, the limitations and exclusions set out above may not apply. This Limited Warranty provides specific legal rights, and other rights may be available, but may vary from province to province.





# Owner's Record

Please complete and retain with your personal records.

Model Name	Serial/Style Number
Purchase Date	(Date which equipment was delivered to original customer.)
Distributor	
Address	
City	
State	Zip



## For Service

**Call 1-800-4-A-Miller or see our website at [www.MillerWelds.com](http://www.MillerWelds.com) to locate a DISTRIBUTOR or SERVICE AGENCY near you.**

Always provide Model Name and Serial/Style Number.

Contact your Distributor for:

- Welding Supplies and Consumables
- Options and Accessories
- Personal Safety Equipment
- Service and Repair
- Replacement Parts
- Training (Schools, Videos, Books)
- Technical Manuals (Servicing Information and Parts)
- Circuit Diagrams
- Welding Process Handbooks

Contact the Delivering Carrier for:

File a claim for loss or damage during shipment.

For assistance in filing or settling claims, contact your distributor and/or equipment manufacturer's Transportation Department.

### Miller Electric Mfg. Co.

An Illinois Tool Works Company  
1635 West Spencer Street  
Appleton, WI 54914 USA

### International Headquarters—USA

USA Phone: 920-735-4505 Auto-Attended  
USA & Canada FAX: 920-735-4134  
International FAX: 920-735-4125

### European Headquarters – United Kingdom

Phone: 44 (0) 1204-593493  
FAX: 44 (0) 1204-598066

[www.MillerWelds.com](http://www.MillerWelds.com)



## Free Manuals Download Website

<http://myh66.com>

<http://usermanuals.us>

<http://www.somanuals.com>

<http://www.4manuals.cc>

<http://www.manual-lib.com>

<http://www.404manual.com>

<http://www.luxmanual.com>

<http://aubethermostatmanual.com>

Golf course search by state

<http://golfingnear.com>

Email search by domain

<http://emailbydomain.com>

Auto manuals search

<http://auto.somanuals.com>

TV manuals search

<http://tv.somanuals.com>