



OM-4409

206 941V

2007-05

Processes



Stick (SMAW) Welding



MIG (GMAW) Welding

Flux Cored (FCAW) Welding



TIG (GTAW) Welding



Air Carbon Arc (CAC-A)
Cutting and Gouging

With Optional Equipment:



Battery Charging

Description



Engine Driven Welding Generator And
Air Compressor

Big Blue[®] Air Pak

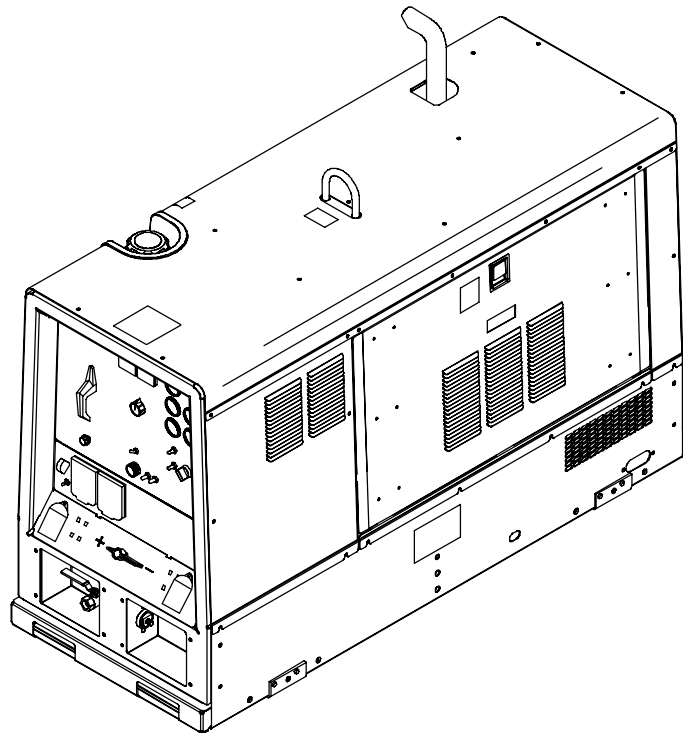

Visit our website at
www.MillerWelds.com

OWNER'S MANUAL

File: Engine Drive



From Miller to You

Thank you and congratulations on choosing Miller. Now you can get the job done and get it done right. We know you don't have time to do it any other way.

That's why when Niels Miller first started building arc welders in 1929, he made sure his products offered long-lasting value and superior quality. Like you, his customers couldn't afford anything less. Miller products had to be more than the best they could be. They had to be the best you could buy.

Today, the people that build and sell Miller products continue the tradition. They're just as committed to providing equipment and service that meets the high standards of quality and value established in 1929.

This Owner's Manual is designed to help you get the most out of your Miller products. Please take time to read the Safety precautions. They will help you protect yourself against potential hazards on the worksite.

We've made installation and operation quick and easy. With Miller you can count on years of reliable service with proper maintenance. And if for some reason the unit needs repair, there's a Troubleshooting section that will help you figure out what the problem is. The parts list will then help you to decide the exact part you may need to fix the problem. Warranty and service information for your particular model are also provided.



Miller is the first welding equipment manufacturer in the U.S.A. to be registered to the ISO 9001:2000 Quality System Standard.

Miller Electric manufactures a full line of welders and welding related equipment. For information on other quality Miller products, contact your local Miller distributor to receive the latest full line catalog or individual specification sheets. **To locate your nearest distributor or service agency call 1-800-4-A-Miller, or visit us at www.MillerWelds.com on the web.**



Working as hard as you do – every power source from Miller is backed by the most hassle-free warranty in the business.



TABLE OF CONTENTS

SECTION 1 – SAFETY PRECAUTIONS – READ BEFORE USING	1
1-1. Symbol Usage	1
1-2. Arc Welding Hazards	1
1-3. Engine Hazards	3
1-4. Compressed Air Hazards	3
1-5. Additional Symbols For Installation, Operation, And Maintenance	4
1-6. California Proposition 65 Warnings	5
1-7. Principal Safety Standards	5
1-8. EMF Information	5
SECTION 2 – CONSIGNES DE SÉCURITÉ – LIRE AVANT UTILISATION	6
2-1. Signification des symboles	6
2-2. Dangers relatifs au soudage à l'arc	6
2-3. Dangers existant en relation avec le moteur	8
2-4. Dangers liés à l'air comprimé	9
2-5. Dangers supplémentaires en relation avec l'installation, le fonctionnement et la maintenance	9
2-6. Proposition californienne 65 Avertissements	11
2-7. Principales normes de sécurité	11
2-8. Information EMF	11
SECTION 3 – DEFINITIONS	12
3-1. Symbols And Definitions	12
SECTION 4 – SPECIFICATIONS	13
4-1. Weld, Power, And Engine Specifications	13
4-2. Air Compressor Specifications	13
4-3. Sound Level Table	13
4-4. Dimensions, Weights, And Operating Angles	14
4-5. Stick And MIG Volt-Ampere Curves	15
4-6. TIG Volt-Ampere Curves	16
4-7. Fuel Consumption	17
4-8. Duty Cycle And Overheating	17
4-9. Generator AC Power Curve	18
4-10. Optional 3-Phase Generator Power Curves	19
4-11. Air Compressor Output Curve	20
4-12. Optional Battery Charging Output Curve	20
4-13. Manufacturing Rating Label	21
SECTION 5 – INSTALLATION	22
5-1. Installing Welding Generator	22
5-2. Mounting Welding Generator	23
5-3. Installing Optional Spark Arrestor Muffler	24
5-4. Activating The Dry Charge Battery (If Applicable)	25
5-5. Connecting The Battery	25
5-6. Using The Optional Battery Disconnect Switch	26
5-7. Engine/Compressor Prestart Checks	27
5-8. Connecting To Weld Output Terminals	28
5-9. Selecting Weld Cable Sizes*	29
5-10. Connecting To Remote 14 Receptacle RC14	30
5-11. Connecting To The Air Compressor	31
SECTION 6 – OPERATING THE WELDING GENERATOR	32
6-1. Controls (See Section 6-2)	32
6-2. Description Of Controls (See Section 6-1)	33
6-3. Process/Contactor Switch	34
6-4. Using Remote Voltage/Amperage Control	35

TABLE OF CONTENTS

SECTION 7 – OPERATING AUXILIARY EQUIPMENT	36
7-1. 120 Volt And 240 Volt Receptacles	36
7-2. Connecting To Optional AC Power Plant	37
7-3. Optional Generator Power Receptacles	38
SECTION 8 – OPERATING OPTIONAL BATTERY CHARGER	39
8-1. Battery Charge Controls	39
8-2. Determining Battery Charging Current	39
8-3. Battery Charge Cable Connections	40
8-4. Battery Charging Procedure	41
8-5. Jump Starting Procedure	42
SECTION 9 – ENGINE/GENERATOR MAINTENANCE	43
9-1. Engine Maintenance Label	43
9-2. Routine Engine/Generator Maintenance	44
9-3. Checking Generator Brushes	45
9-4. Servicing Engine Air Cleaner	46
9-5. Inspecting/Cleaning Optional Spark Arrestor Muffler	47
9-6. Adjusting Engine Speed	48
9-7. Servicing Engine Fuel And Lubrication Systems	49
9-8. Engine/Generator Overload Protection	50
SECTION 10 – AIR COMPRESSOR MAINTENANCE	51
10-1. Air Compressor Maintenance Label	51
10-2. Routine Air Compressor Maintenance	52
10-3. Servicing Compressor Air Cleaner	53
10-4. Compressor Overload Protection	54
10-5. Servicing Air Compressor	55
10-6. Adjusting Compressor Air Pressure	56
SECTION 11 – TROUBLESHOOTING	57
11-1. Troubleshooting Tables	57
SECTION 12 – AIR COMPRESSOR DIAGRAM	61
SECTION 13 – CIRCUIT DIAGRAM	62
SECTION 14 – RUN-IN PROCEDURE	64
14-1. Wetstacking	64
14-2. Run-In Procedure Using Load Bank	65
14-3. Run-In Procedure Using Resistance Grid	66
SECTION 15 – AIR COMPRESSOR TABLES	67
15-1. Flow Of Free Air (CFM) Through Orifices Of Various Diameters	67
15-2. Approximate Air Consumption (Cubic Feet) To Operate Pneumatic Equipment At 70-90 P.S.I.G. ...	68
SECTION 16 – GENERATOR POWER GUIDELINES	69
SECTION 17 – SELECTING AND PREPARING A TUNGSTEN FOR DC OR AC WELDING	76
17-1. Selecting Tungsten Electrode (Wear Clean gloves To Prevent Contamination Of Tungsten)	76
17-2. Preparing Tungsten Electrode For Welding With Phase Control Machines	76
SECTION 18 – GUIDELINES FOR TIG WELDING (GTAW)	77
18-1. Positioning The Torch	77
18-2. Torch Movement During Welding	78
18-3. Positioning Torch Tungsten For Various Weld Joints	79
SECTION 19 – PARTS LIST	80
WARRANTY	

SECTION 1 – SAFETY PRECAUTIONS – READ BEFORE USING

rom_2007-04

 Protect yourself and others from injury — read and follow these precautions.

1-1. Symbol Usage



DANGER! – Indicates a hazardous situation which, if not avoided, will result in death or serious injury. The possible hazards are shown in the adjoining symbols or explained in the text.



Indicates a hazardous situation which, if not avoided, could result in death or serious injury. The possible hazards are shown in the adjoining symbols or explained in the text.

NOTICE – Indicates statements not related to personal injury.

 Indicates special instructions.



This group of symbols means Warning! Watch Out! ELECTRIC SHOCK, MOVING PARTS, and HOT PARTS hazards. Consult symbols and related instructions below for necessary actions to avoid the hazards.

1-2. Arc Welding Hazards



The symbols shown below are used throughout this manual to call attention to and identify possible hazards. When you see the symbol, watch out, and follow the related instructions to avoid the hazard. The safety information given below is only a summary of the more complete safety information found in the Safety Standards listed in Section 1-7. Read and follow all Safety Standards.



Only qualified persons should install, operate, maintain, and repair this unit.



During operation, keep everybody, especially children, away.



ELECTRIC SHOCK can kill.

Touching live electrical parts can cause fatal shocks or severe burns. The electrode and work circuit is electrically live whenever the output is on. The input power circuit and machine internal circuits are also live when power is on. In semiautomatic or automatic wire welding, the wire, wire reel, drive roll housing, and all metal parts touching the welding wire are electrically live. Incorrectly installed or improperly grounded equipment is a hazard.

- Do not touch live electrical parts.
- Wear dry, hole-free insulating gloves and body protection.
- Insulate yourself from work and ground using dry insulating mats or covers big enough to prevent any physical contact with the work or ground.
- Do not use AC output in damp areas, if movement is confined, or if there is a danger of falling.
- Use AC output ONLY if required for the welding process.
- If AC output is required, use remote output control if present on unit.
- Additional safety precautions are required when any of the following electrically hazardous conditions are present: in damp locations or while wearing wet clothing; on metal structures such as floors, gratings, or scaffolds; when in cramped positions such as sitting, kneeling, or lying; or when there is a high risk of unavoidable or accidental contact with the workpiece or ground. For these conditions, use the following equipment in order presented: 1) a semiautomatic DC constant voltage (wire) welder, 2) a DC manual (stick) welder, or 3) an AC welder with reduced open-circuit voltage. In most situations, use of a DC, constant voltage wire welder is recommended. And, do not work alone!
- Disconnect input power or stop engine before installing or servicing this equipment. Lockout/tagout input power according to OSHA 29 CFR 1910.147 (see Safety Standards).
- Properly install and ground this equipment according to its Owner's Manual and national, state, and local codes.

- Always verify the supply ground — check and be sure that input power cord ground wire is properly connected to ground terminal in disconnect box or that cord plug is connected to a properly grounded receptacle outlet.
- When making input connections, attach proper grounding conductor first – double-check connections.
- Keep cords dry, free of oil and grease, and protected from hot metal and sparks.
- Frequently inspect input power cord for damage or bare wiring — replace cord immediately if damaged — bare wiring can kill.
- Turn off all equipment when not in use.
- Do not use worn, damaged, undersized, or poorly spliced cables.
- Do not drape cables over your body.
- If earth grounding of the workpiece is required, ground it directly with a separate cable.
- Do not touch electrode if you are in contact with the work, ground, or another electrode from a different machine.
- Use only well-maintained equipment. Repair or replace damaged parts at once. Maintain unit according to manual.
- Do not touch electrode holders connected to two welding machines at the same time since double open-circuit voltage will be present.
- Wear a safety harness if working above floor level.
- Keep all panels and covers securely in place.
- Clamp work cable with good metal-to-metal contact to workpiece or worktable as near the weld as practical.
- Insulate work clamp when not connected to workpiece to prevent contact with any metal object.
- Do not connect more than one electrode or work cable to any single weld output terminal.

SIGNIFICANT DC VOLTAGE exists in inverters after stopping engine.

- Stop engine on inverter and discharge input capacitors according to instructions in Maintenance Section before touching any parts.



HOT PARTS can cause severe burns.

- Do not touch hot parts bare handed.
- Allow cooling period before working on equipment.
- To handle hot parts, use proper tools and/or wear heavy, insulated welding gloves and clothing to prevent burns.

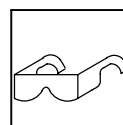

FLYING METAL or DIRT can injure eyes.

- Welding, chipping, wire brushing, and grinding cause sparks and flying metal. As welds cool, they can throw off slag.
- Wear approved safety glasses with side shields even under your welding helmet.



FUMES AND GASES can be hazardous.

Welding produces fumes and gases. Breathing these fumes and gases can be hazardous to your health.

- Keep your head out of the fumes. Do not breathe the fumes.
- If inside, ventilate the area and/or use local forced ventilation at the arc to remove welding fumes and gases.
- If ventilation is poor, wear an approved air-supplied respirator.
- Read and understand the Material Safety Data Sheets (MSDSs) and the manufacturer's instructions for metals, consumables, coatings, cleaners, and degreasers.
- Work in a confined space only if it is well ventilated, or while wearing an air-supplied respirator. Always have a trained watch-person nearby. Welding fumes and gases can displace air and lower the oxygen level causing injury or death. Be sure the breathing air is safe.
- Do not weld in locations near degreasing, cleaning, or spraying operations. The heat and rays of the arc can react with vapors to form highly toxic and irritating gases.
- Do not weld on coated metals, such as galvanized, lead, or cadmium plated steel, unless the coating is removed from the weld area, the area is well ventilated, and while wearing an air-supplied respirator. The coatings and any metals containing these elements can give off toxic fumes if welded.



BUILDUP OF GAS can injure or kill.

- Shut off shielding gas supply when not in use.
- Always ventilate confined spaces or use approved air-supplied respirator.



ARC RAYS can burn eyes and skin.

Arc rays from the welding process produce intense visible and invisible (ultraviolet and infrared) rays that can burn eyes and skin. Sparks fly off from the weld.

- Wear an approved welding helmet fitted with a proper shade of filter lenses to protect your face and eyes from arc rays and sparks when welding or watching (see ANSI Z49.1 and Z87.1 listed in Safety Standards).
- Wear approved safety glasses with side shields under your helmet.
- Use protective screens or barriers to protect others from flash, glare, and sparks; warn others not to watch the arc.
- Wear protective clothing made from durable, flame-resistant material (leather, heavy cotton, or wool) and foot protection.



WELDING can cause fire or explosion.

Welding on closed containers, such as tanks, drums, or pipes, can cause them to blow up. Sparks can fly off from the welding arc. The flying sparks, hot workpiece, and hot equipment can cause fires and burns. Accidental contact of electrode to metal objects can cause sparks, explosion, overheating, or fire. Check and be sure the area is safe before doing any welding.

- Remove all flammables within 35 ft (10.7 m) of the welding arc. If this is not possible, tightly cover them with approved covers.
- Do not weld where flying sparks can strike flammable material.
- Protect yourself and others from flying sparks and hot metal.
- Be alert that welding sparks and hot materials from welding can easily go through small cracks and openings to adjacent areas.
- Watch for fire, and keep a fire extinguisher nearby.
- Be aware that welding on a ceiling, floor, bulkhead, or partition can cause fire on the hidden side.

- Do not weld on closed containers such as tanks, drums, or pipes, unless they are properly prepared according to AWS F4.1 (see Safety Standards).
- Do not weld where the atmosphere may contain flammable dust, gas, or liquid vapors (such as gasoline).
- Connect work cable to the work as close to the welding area as practical to prevent welding current from traveling long, possibly unknown paths and causing electric shock, sparks, and fire hazards.
- Do not use welder to thaw frozen pipes.
- Remove stick electrode from holder or cut off welding wire at contact tip when not in use.
- Wear oil-free protective garments such as leather gloves, heavy shirt, cuffless trousers, high shoes, and a cap.
- Remove any combustibles, such as a butane lighter or matches, from your person before doing any welding.
- After completion of work, inspect area to ensure it is free of sparks, glowing embers, and flames.
- Use only correct fuses or circuit breakers. Do not oversize or bypass them.
- Follow requirements in OSHA 1910.252 (a) (2) (iv) and NFPA 51B for hot work and have a fire watcher and extinguisher nearby.



NOISE can damage hearing.

Noise from some processes or equipment can damage hearing.

- Wear approved ear protection if noise level is high.



MAGNETIC FIELDS can affect Implanted Medical Devices.

- Wearers of Pacemakers and other Implanted Medical Devices should keep away.
- Implanted Medical Device wearers should consult their doctor and the device manufacturer before going near arc welding, spot welding, gouging, plasma arc cutting, or induction heating operations.

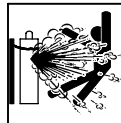

CYLINDERS can explode if damaged.

Shielding gas cylinders contain gas under high pressure. If damaged, a cylinder can explode. Since gas cylinders are normally part of the welding process, be sure to treat them carefully.

- Protect compressed gas cylinders from excessive heat, mechanical shocks, physical damage, slag, open flames, sparks, and arcs.
- Install cylinders in an upright position by securing to a stationary support or cylinder rack to prevent falling or tipping.
- Keep cylinders away from any welding or other electrical circuits.
- Never drape a welding torch over a gas cylinder.
- Never allow a welding electrode to touch any cylinder.
- Never weld on a pressurized cylinder — explosion will result.
- Use only correct shielding gas cylinders, regulators, hoses, and fittings designed for the specific application; maintain them and associated parts in good condition.
- Turn face away from valve outlet when opening cylinder valve.
- Keep protective cap in place over valve except when cylinder is in use or connected for use.
- Use the right equipment, correct procedures, and sufficient number of persons to lift and move cylinders.
- Read and follow instructions on compressed gas cylinders, associated equipment, and Compressed Gas Association (CGA) publication P-1 listed in Safety Standards.

1-3. Engine Hazards



BATTERY EXPLOSION can BLIND.

- Always wear a face shield, rubber gloves, and protective clothing when working on a battery.
- Stop engine before disconnecting or connecting battery cables or servicing battery.
- Do not allow tools to cause sparks when working on a battery.
- Do not use welder to charge batteries or jump start vehicles.
- Observe correct polarity (+ and -) on batteries.
- Disconnect negative (-) cable first and connect it last.



FUEL can cause fire or explosion.

- Stop engine and let it cool off before checking or adding fuel.
- Do not add fuel while smoking or if unit is near any sparks or open flames.
- Do not overfill tank — allow room for fuel to expand.
- Do not spill fuel. If fuel is spilled, clean up before starting engine.
- Dispose of rags in a fireproof container.
- Always keep nozzle in contact with tank when fueling.



MOVING PARTS can cause injury.

- Keep away from fans, belts, and rotors.
- Keep all doors, panels, covers, and guards closed and securely in place.
- Stop engine before installing or connecting unit.
- Have only qualified people remove doors, panels, covers, or guards for maintenance and troubleshooting as necessary.
- To prevent accidental starting during servicing, disconnect negative (-) battery cable from battery.
- Keep hands, hair, loose clothing, and tools away from moving parts.
- Reinstall doors, panels, covers, or guards when servicing is finished and before starting engine.
- Before working on generator, remove spark plugs or injectors to keep engine from kicking back or starting.
- Block flywheel so that it will not turn while working on generator components.



HOT PARTS can cause severe burns.

- Do not touch hot parts bare handed.
- Allow cooling period before working on equipment.
- To handle hot parts, use proper tools and/or wear heavy, insulated welding gloves and clothing to prevent burns.

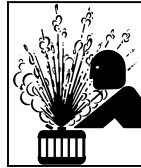

STEAM AND HOT COOLANT can burn.

- If possible, check coolant level when engine is cold to avoid scalding.
- Always check coolant level at overflow tank, if present on unit, instead of radiator (unless told otherwise in maintenance section or engine manual).
- If the engine is warm, checking is needed, and there is no overflow tank, follow the next two statements.
- Wear safety glasses and gloves and put a rag over radiator cap.
- Turn cap slightly and let pressure escape slowly before completely removing cap.

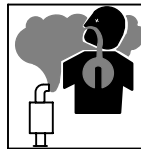

Using a generator indoors CAN KILL YOU IN MINUTES.

- Generator exhaust contains carbon monoxide. This is a poison you cannot see or smell.
- NEVER use inside a home or garage, EVEN IF doors and windows are open.
- Only use OUTSIDE and far away from windows, doors, and vents.

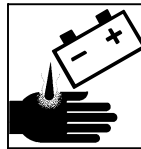

BATTERY ACID can BURN SKIN and EYES.

- Do not tip battery.
- Replace damaged battery.
- Flush eyes and skin immediately with water.



ENGINE HEAT can cause fire.

- Do not locate unit on, over, or near combustible surfaces or flammables.
- Keep exhaust and exhaust pipes way from flammables.



EXHAUST SPARKS can cause fire.

- Do not let engine exhaust sparks cause fire.
- Use approved engine exhaust spark arrestor in required areas — see applicable codes.

1-4. Compressed Air Hazards



BREATHING COMPRESSED AIR can cause serious injury or death.

- Do not use compressed air for breathing.
- Use only for cutting, gouging, and tools.

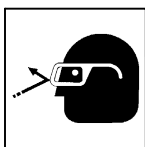

COMPRESSED AIR can cause injury.

- Wear approved safety goggles.
- Do not direct air stream toward self or others.

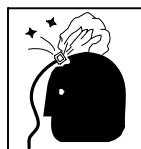

TRAPPED AIR PRESSURE AND WHIPPING HOSES can cause injury.

- Release air pressure from tools and system before servicing, adding or changing attachments, or opening compressor oil drain or oil fill cap.



HOT METAL from air arc cutting and gouging can cause fire or explosion.

- Do not cut or gouge near flammables.
- Watch for fire; keep extinguisher nearby.



HOT PARTS can cause burns and injury.

- Do not touch hot compressor or air system parts.
- Let system cool down before touching or servicing.

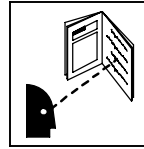

READ INSTRUCTIONS.

- Read Owner's Manual before using or servicing unit.
- Stop engine and release air pressure before servicing.
- Use only genuine replacement parts from the manufacturer.

1-5. Additional Symbols For Installation, Operation, And Maintenance



FIRE OR EXPLOSION hazard.

- Do not install or place unit on, over, or near combustible surfaces.
- Do not install unit near flammables.
- Do not overload building wiring – be sure power supply system is properly sized, rated, and protected to handle this unit.

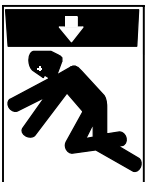

FALLING UNIT can cause injury.

- Use lifting eye to lift unit and properly installed accessories only, NOT gas cylinders. Do not exceed maximum lift eye weight rating (see Specifications).
- Lift and support unit only with proper equipment and correct procedures.
- If using lift forks to move unit, be sure forks are long enough to extend beyond opposite side of unit.

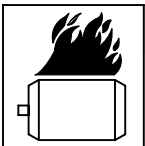

OVERHEATING can damage motors.

- Turn off or unplug equipment before starting or stopping engine.
- Do not let low voltage and frequency caused by low engine speed damage electric motors.
- Do not connect 50 or 60 Hertz motors to the 100 Hertz receptacle where applicable.

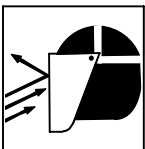

FLYING SPARKS can cause injury.

- Wear a face shield to protect eyes and face.
- Shape tungsten electrode only on grinder with proper guards in a safe location wearing proper face, hand, and body protection.
- Sparks can cause fires — keep flammables away.



MOVING PARTS can cause injury.

- Keep away from moving parts.
- Keep away from pinch points such as drive rolls.

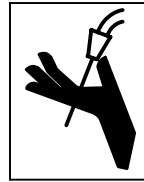

WELDING WIRE can cause injury.

- Do not press gun trigger until instructed to do so.
- Do not point gun toward any part of the body, other people, or any metal when threading welding wire.

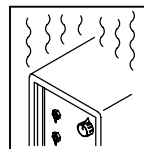

OVERUSE can cause OVERHEATING.

- Allow cooling period; follow rated duty cycle.
- Reduce current or reduce duty cycle before starting to weld again.
- Do not block or filter airflow to unit.

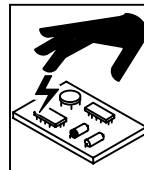

STATIC (ESD) can damage PC boards.

- Put on grounded wrist strap BEFORE handling boards or parts.
- Use proper static-proof bags and boxes to store, move, or ship PC boards.

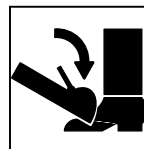

TILTING OF TRAILER can cause injury.

- Use tongue jack or blocks to support weight.
- Properly install welding generator onto trailer according to instructions supplied with trailer.

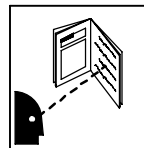

READ INSTRUCTIONS.

- Read Owner's Manual before using or servicing unit.
- Use only genuine replacement parts from the manufacturer.
- Perform engine and air compressor maintenance and service according to this manual and the engine/air compressor (if applicable) manuals.

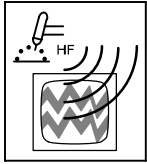

H.F. RADIATION can cause interference.

- High-frequency (H.F.) can interfere with radio navigation, safety services, computers, and communications equipment.
- Have only qualified persons familiar with electronic equipment perform this installation.
- The user is responsible for having a qualified electrician promptly correct any interference problem resulting from the installation.
- If notified by the FCC about interference, stop using the equipment at once.
- Have the installation regularly checked and maintained.
- Keep high-frequency source doors and panels tightly shut, keep spark gaps at correct setting, and use grounding and shielding to minimize the possibility of interference.

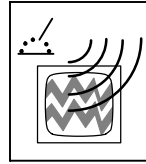

ARC WELDING can cause interference.

- Electromagnetic energy can interfere with sensitive electronic equipment such as micro-processors, computers, and computer-driven equipment such as robots.
- Be sure all equipment in the welding area is electromagnetically compatible.
- To reduce possible interference, keep weld cables as short as possible, close together, and down low, such as on the floor.
- Locate welding operation 100 meters from any sensitive electronic equipment.
- Be sure this welding machine is installed and grounded according to this manual.
- If interference still occurs, the user must take extra measures such as moving the welding machine, using shielded cables, using line filters, or shielding the work area.

1-6. California Proposition 65 Warnings

- ⚠ Welding or cutting equipment produces fumes or gases which contain chemicals known to the State of California to cause birth defects and, in some cases, cancer. (California Health & Safety Code Section 25249.5 et seq.)**
- ⚠ Battery posts, terminals and related accessories contain lead and lead compounds, chemicals known to the State of California to cause cancer and birth defects or other reproductive harm. Wash hands after handling.**

For Gasoline Engines:

- ⚠ Engine exhaust contains chemicals known to the State of California to cause cancer, birth defects, or other reproductive harm.**

For Diesel Engines:

- ⚠ Diesel engine exhaust and some of its constituents are known to the State of California to cause cancer, birth defects, and other reproductive harm.**

1-7. Principal Safety Standards

Safety in Welding, Cutting, and Allied Processes, ANSI Standard Z49.1, from Global Engineering Documents (phone: 1-877-413-5184, website: www.global.ihs.com).

Recommended Safe Practices for the Preparation for Welding and Cutting of Containers and Piping, American Welding Society Standard AWS F4.1, from Global Engineering Documents (phone: 1-877-413-5184, website: www.global.ihs.com).

National Electrical Code, NFPA Standard 70, from National Fire Protection Association, P.O. Box 9101, Quincy, MA 02269-9101 (phone: 617-770-3000, website: www.nfpa.org and www.sparky.org).

Safe Handling of Compressed Gases in Cylinders, CGA Pamphlet P-1, from Compressed Gas Association, 4221 Walney Road, 5th Floor, Chantilly, VA 20151 (phone: 703-788-2700, website: www.cganet.com).

Code for Safety in Welding and Cutting, CSA Standard W117.2, from Canadian Standards Association, Standards Sales, 5060 Mississauga,

Ontario, Canada L4W 5NS (phone: 800-463-6727 or in Toronto 416-747-4044, website: www.csa-international.org).

Safe Practice For Occupational And Educational Eye And Face Protection, ANSI Standard Z87.1, from American National Standards Institute, 25 West 43rd Street, New York, NY 10036-8002 (phone: 212-642-4900, website: www.ansi.org).

Standard for Fire Prevention During Welding, Cutting, and Other Hot Work, NFPA Standard 51B, from National Fire Protection Association, P.O. Box 9101, Quincy, MA 02269-9101 (phone: 617-770-3000, website: www.nfpa.org).

OSHA, Occupational Safety and Health Standards for General Industry, Title 29, Code of Federal Regulations (CFR), Part 1910, Subpart Q, and Part 1926, Subpart J, from U.S. Government Printing Office, Superintendent of Documents, P.O. Box 371954, Pittsburgh, PA 15250-7954 (phone: 1-866-512-1800) (there are 10 Regional Offices—phone for Region 5, Chicago, is 312-353-2220, website: www.osha.gov).

1-8. EMF Information

Considerations About Welding And The Effects Of Low Frequency Electric And Magnetic Fields

Welding current, as it flows through welding cables, will cause electromagnetic fields. There has been and still is some concern about such fields. However, after examining more than 500 studies spanning 17 years of research, a special blue ribbon committee of the National Research Council concluded that: "The body of evidence, in the committee's judgment, has not demonstrated that exposure to power-frequency electric and magnetic fields is a human-health hazard." However, studies are still going forth and evidence continues to be examined. Until the final conclusions of the research are reached, you may wish to minimize your exposure to electromagnetic fields when welding or cutting.

To reduce magnetic fields in the workplace, use the following procedures:

1. Keep cables close together by twisting or taping them, or using a cable cover.
2. Arrange cables to one side and away from the operator.
3. Do not coil or drape cables around your body.
4. Keep welding power source and cables as far away from operator as practical.
5. Connect work clamp to workpiece as close to the weld as possible.

About Implanted Medical Devices:

Implanted Medical Device wearers should consult their doctor and the device manufacturer before performing or going near arc welding, spot welding, gouging, plasma arc cutting, or induction heating operations. If cleared by your doctor, then following the above procedures is recommended.

SECTION 2 – CONSIGNES DE SÉCURITÉ – LIRE AVANT UTILISATION

rom_2007-04fre

! Se protéger, ainsi que toute autre personne travaillant sur les lieux, contre les étincelles et le métal chaud.

2-1. Signification des symboles



DANGER! – Indique une situation dangereuse qui si on l'évite pas peut donner la mort ou des blessures graves. Les dangers possibles sont montrés par les symboles joints ou sont expliqués dans le texte.



Indique une situation dangereuse qui si on l'évite pas peut donner la mort ou des blessures graves. Les dangers possibles sont montrés par les symboles joints ou sont expliqués dans le texte.

NOTE – Indique des déclarations pas en relation avec des blessures personnelles.

 Indique des instructions spécifiques.



Ce groupe de symboles veut dire Avertissement! Attention! DANGER DE CHOC ELECTRIQUE, PIECES EN MOUVEMENT, et PIECES CHAUDES. Consulter les symboles et les instructions ci-dessous y afférant pour les actions nécessaires afin d'éviter le danger.

2-2. Dangers relatifs au soudage à l'arc



Les symboles présentés ci-après sont utilisés tout au long du présent manuel pour attirer votre attention et identifier les risques de danger. Lorsque vous voyez un symbole, soyez vigilant et suivez les directives mentionnées afin d'éviter tout danger. Les consignes de sécurité présentées ci-après ne font que résumer l'information contenue dans les normes de sécurité énumérées à la section 2-7. Veuillez lire et respecter toutes ces normes de sécurité.



L'installation, l'utilisation, l'entretien et les réparations ne doivent être confiés qu'à des personnes qualifiées.



Au cours de l'utilisation, tenir toute personne à l'écart et plus particulièrement les enfants.



UN CHOC ÉLECTRIQUE peut tuer.

Un simple contact avec des pièces électriques peut provoquer une électrocution ou des blessures graves. L'électrode et le circuit de soudage sont sous tension

dès que l'appareil est sur ON. Le circuit d'entrée et les circuits internes de l'appareil sont également sous tension à ce moment-là. En soudage semi-automatique ou automatique, le fil, le dévidoir, le logement des galets d'entraînement et les pièces métalliques en contact avec le fil de soudage sont sous tension. Des matériels mal installés ou mal mis à la terre présentent un danger.

- Ne jamais toucher les pièces électriques sous tension.
- Porter des gants et des vêtements de protection secs ne comportant pas de trous.
- S'isoler de la pièce et de la terre au moyen de tapis ou d'autres moyens isolants suffisamment grands pour empêcher le contact physique éventuel avec la pièce ou la terre.
- Ne pas se servir de source électrique à courant électrique dans les zones humides, dans les endroits confinés ou là où on risque de tomber.
- Se servir d'une source électrique à courant électrique UNIQUEMENT si le procédé de soudage le demande.
- Si l'utilisation d'une source électrique à courant électrique s'avère nécessaire, se servir de la fonction de télécommande si l'appareil en est équipé.
- Des précautions de sécurité supplémentaires sont requises dans des environnements à risque comme: les endroits humides ou lorsque l'on porte des vêtements mouillés; sur des structures métalliques au sol, grillages et échafaudages; dans des positions assises, à genoux et allongées; ou quand il y a un risque important de contact accidentel avec la pièce ou le sol. Dans ces cas utiliser les appareils suivants dans l'ordre de préférence: 1) un poste à souder DC semi-automatique de type CV (MIG/MAG), 2) un poste à souder manuel (électrode enrobée) DC, 3) un poste à souder

manuel AC avec tension à vide réduite. Dans la plupart des cas, un poste courant continu de type CV est recommandé. Et, ne pas travailler seul!

- Couper l'alimentation ou arrêter le moteur avant de procéder à l'installation, à la réparation ou à l'entretien de l'appareil. Déverrouiller l'alimentation selon la norme OSHA 29 CFR 1910.147 (voir normes de sécurité).
- Installer et mettre à la terre correctement cet appareil conformément à son manuel d'utilisation et aux codes nationaux, provinciaux et municipaux.
- Toujours vérifier la terre du cordon d'alimentation – Vérifier et s'assurer que le fil de terre du cordon d'alimentation est bien raccordé à la borne de terre du sectionneur ou que la fiche du cordon est raccordée à une prise correctement mise à la terre.
- En effectuant les raccordements d'entrée fixer d'abord le conducteur de mise à la terre approprié et contre-vérifier les connexions.
- Les câbles doivent être exempts d'humidité, d'huile et de graisse; protégez-les contre les étincelles et les pièces métalliques chaudes.
- Vérifier fréquemment le cordon d'alimentation pour voir s'il n'est pas endommagé ou dénudé – remplacer le cordon immédiatement s'il est endommagé – un câble dénudé peut provoquer une électrocution.
- Mettre l'appareil hors tension quand on ne l'utilise pas.
- Ne pas utiliser des câbles usés, endommagés, de grosseur insuffisante ou mal épissés.
- Ne pas enrouler les câbles autour du corps.
- Si la pièce soudée doit être mise à la terre, le faire directement avec un câble distinct – ne pas utiliser le connecteur de pièce ou le câble de retour.
- Ne pas toucher l'électrode quand on est en contact avec la pièce, la terre ou une électrode provenant d'une autre machine.
- Ne pas toucher des porte électrodes connectés à deux machines en même temps à cause de la présence d'une tension à vide doublée.
- N'utiliser qu'un matériel en bon état. Réparer ou remplacer sur-le-champ les pièces endommagées. Entretien l'appareil conformément à ce manuel.
- Porter un harnais de sécurité quand on travaille en hauteur.
- Maintenir solidement en place tous les panneaux et capots.
- Fixer le câble de retour de façon à obtenir un bon contact métal-métal avec la pièce à souder ou la table de travail, le plus près possible de la soudure.
- Isoler la pince de masse quand pas mis à la pièce pour éviter le contact avec tout objet métallique.

Une tension DC importante subsiste à l'intérieur des onduleurs après avoir coupé l'alimentation.

- Couper l'alimentation du poste et décharger les condensateurs d'entrée comme indiqué dans la Section Maintenance avant de toucher des composants.



DES PIÈCES CHAUDES peuvent provoquer des brûlures graves.

- Ne pas toucher à mains nues les parties chaudes.
- Prévoir une période de refroidissement avant de travailler à l'équipement.
- Ne pas toucher aux pièces chaudes, utiliser les outils recommandés et porter des gants de soudage et des vêtements épais pour éviter les brûlures.

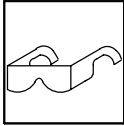

DES PIÈCES DE METAL ou DES SALETES peuvent provoquer des blessures dans les yeux.

- Le soudage, l'écaillage, le passage de la pièce à la brosse en fil de fer, et le meulage génèrent des étincelles et des particules métalliques volantes. Pendant la période de refroidissement des soudures, elles risquent de projeter du laitier.
- Porter des lunettes de sécurité avec écrans latéraux ou un écran facial.



LES FUMÉES ET LES GAZ peuvent être dangereux.

Le soudage génère des fumées et des gaz. Leur inhalation peut être dangereux pour votre santé.

- Eloigner votre tête des fumées. Ne pas respirer les fumées.
- À l'intérieur, ventiler la zone et/ou utiliser une ventilation forcée au niveau de l'arc pour l'évacuation des fumées et des gaz de soudage.
- Si la ventilation est médiocre, porter un respirateur anti-vapeurs approuvé.
- Lire et comprendre les spécifications de sécurité des matériaux (MSDS) et les instructions du fabricant concernant les métaux, les consommables, les revêtements, les nettoyants et les dégraissants.
- Travailler dans un espace fermé seulement s'il est bien ventilé ou en portant un respirateur à alimentation d'air. Demander toujours à un surveillant dûment formé de se tenir à proximité. Des fumées et des gaz de soudage peuvent déplacer l'air et abaisser le niveau d'oxygène provoquant des blessures ou des accidents mortels. S'assurer que l'air de respiration ne présente aucun danger.
- Ne pas souder dans des endroits situés à proximité d'opérations de dégraissage, de nettoyage ou de pulvérisation. La chaleur et les rayons de l'arc peuvent réagir en présence de vapeurs et former des gaz hautement toxiques et irritants.
- Ne pas souder des métaux munis d'un revêtement, tels que l'acier galvanisé, plaqué en plomb ou au cadmium à moins que le revêtement n'ait été enlevé dans la zone de soudure, que l'endroit soit bien ventilé, et en portant un respirateur à alimentation d'air. Les revêtements et tous les métaux renfermant ces éléments peuvent dégager des fumées toxiques en cas de soudage.



LES ACCUMULATIONS DE GAZ risquent de provoquer des blessures ou même la mort.

- Fermer l'alimentation du gaz protecteur en cas de non utilisation.
- Veiller toujours à bien aérer les espaces confinés ou se servir d'un respirateur d'adduction d'air homologué.

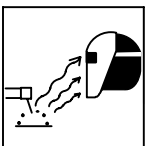

LES RAYONS DE L'ARC peuvent provoquer des brûlures dans les yeux et sur la peau.

Le rayonnement de l'arc du procédé de soudage génère des rayons visibles et invisibles intense (ultraviolets et infrarouges) susceptibles de provoquer des brûlures dans les yeux et sur la peau. Des étincelles sont projetées pendant le soudage.

- Porter un casque de soudage approuvé muni de verres filtrants appropriés pour protéger visage et yeux pendant le soudage (voir ANSI Z49.1 et Z87.1 énuméré dans les normes de sécurité).
- Porter des lunettes de sécurité avec écrans latéraux même sous votre casque.
- Avoir recours à des écrans protecteurs ou à des rideaux pour protéger les autres contre les rayonnements les éblouissements et les étincelles ; prévenir toute personne sur les lieux de ne pas regarder l'arc.
- Porter des vêtements confectionnés avec des matières résistantes et ignifuges (cuir, coton lourd ou laine) et des bottes de protection.

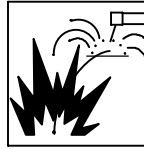

LE SOUDAGE peut provoquer un incendie ou une explosion.

Le soudage effectué sur des conteneurs fermés tel que des réservoirs, tambours ou des conduites peut provoquer leur éclatement. Des étincelles peuvent être projetées de l'arc de soudure. La projection d'étincelles, des pièces chaudes et des équipements chauds peut provoquer des incendies et des brûlures. Le contact accidentel de l'électrode avec des objets métalliques peut provoquer des étincelles, une explosion, un surchauffement ou un incendie. Avant de commencer le soudage, vérifier et s'assurer que l'endroit ne présente pas de danger.

- Déplacer toutes les substances inflammables à une distance de 10,7 m de l'arc de soudage. En cas d'impossibilité les recouvrir soigneusement avec des protections homologués.
- Ne pas souder dans un endroit où des étincelles peuvent tomber sur des substances inflammables.
- Se protéger et d'autres personnes de la projection d'étincelles et de métal chaud.
- Des étincelles et des matériaux chauds du soudage peuvent facilement passer dans d'autres zones en traversant de petites fissures et des ouvertures.
- Surveiller tout déclenchement d'incendie et tenir un extincteur à proximité.
- Le soudage effectué sur un plafond, plancher, paroi ou séparation peut déclencher un incendie de l'autre côté.
- Ne pas effectuer le soudage sur des conteneurs fermés tels que des réservoirs, tambours, ou conduites, à moins qu'ils n'aient été préparés correctement conformément à AWS F4.1 (voir les normes de sécurité).
- Ne soudez pas si l'air ambiant est chargé de particules, gaz, ou vapeurs inflammables (vapeur d'essence, par exemple).
- Brancher le câble de masse sur la pièce la plus près possible de la zone de soudage pour éviter le transport du courant sur une longue distance par des chemins inconnus éventuels en provoquant des risques d'électrocution, d'étincelles et d'incendie.
- Ne pas utiliser le poste de soudage pour dégeler des conduites gelées.
- En cas de non utilisation, enlever la baguette d'électrode du porte-électrode ou couper le fil à la pointe de contact.
- Porter des vêtements de protection dépourvus d'huile tels que des gants en cuir, une chemise en matériau lourd, des pantalons sans revers, des chaussures hautes et un couvre chef.
- Avant de souder, retirer toute substance combustible de vos poches telles qu'un allumeur au butane ou des allumettes.
- Une fois le travail achevé, assurez-vous qu'il ne reste aucune trace d'étincelles incandescentes ni de flammes.
- Utiliser exclusivement des fusibles ou coupe-circuits appropriés. Ne pas augmenter leur puissance; ne pas les ponter.
- Suivre les recommandations dans OSHA 1910.252(a)(2)(iv) et NFPA 51B pour les travaux à chaud et avoir de la surveillance et un extincteur à proximité.

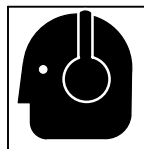

LE BRUIT peut affecter l'ouïe.

Le bruit des processus et des équipements peut affecter l'ouïe.

- Porter des protections approuvées pour les oreilles si le niveau sonore est trop élevé.



LES CHAMPS MAGNETIQUES peuvent affecter des implants médicaux.

- Porteur de simulateur cardiaque ou autre implants médicaux, rester à distance.
- Les porteurs d'implants doivent d'abord consulter leur médecin avant de s'approcher des opérations de soudage à l'arc, de soudage par points, de gougeage, du coupage plasma ou de chauffage par induction.

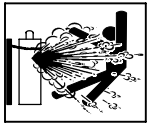

Si des BOUTEILLES sont endommagées, elles pourront exploser.

Des bouteilles de gaz protecteur contiennent du gaz sous haute pression. Si une bouteille est endommagée, elle peut exploser. Du fait que les bouteilles de gaz forment normalement partie du procédé de soudage, les manipuler avec précaution.

- Protéger les bouteilles de gaz comprimé d'une chaleur excessive, des chocs mécaniques, des dommages physiques, du laitier, des flammes ouvertes, des étincelles et des arcs.

- Placer les bouteilles debout en les fixant dans un support stationnaire ou dans un porte-bouteilles pour les empêcher de tomber ou de se renverser.
- Tenir les bouteilles éloignées des circuits de soudage ou autres circuits électriques.
- Ne jamais placer une torche de soudage sur une bouteille à gaz.
- Une électrode de soudage ne doit jamais entrer en contact avec une bouteille.
- Ne jamais souder une bouteille pressurisée – risque d'explosion.
- Utiliser seulement des bouteilles de gaz protecteur, régulateurs, tuyaux et raccords convenables pour cette application spécifique; les maintenir ainsi que les éléments associés en bon état.
- Ne pas tenir la tête en face de la sortie en ouvrant la soupape de la bouteille.
- Maintenir le chapeau de protection sur la soupape, sauf en cas d'utilisation ou de branchement de la bouteille.
- Utiliser les équipements corrects, les bonnes procédures et suffisamment de personnes pour soulever et déplacer les bouteilles.
- Lire et suivre les instructions sur les bouteilles de gaz comprimé, l'équipement connexe et le dépliant P-1 de la CGA (Compressed Gas Association) mentionné dans les principales normes de sécurité.

2-3. Dangers existant en relation avec le moteur

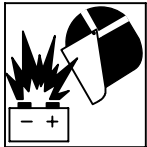

L'EXPLOSION DE LA BATTERIE peut RENDRE AVEUGLE.

- Toujours porter une protection faciale, des gants en caoutchouc et vêtements de protection lors d'une intervention sur la batterie.
- Arrêter le moteur avant de débrancher ou de brancher les câbles de batterie.
- Eviter de provoquer des étincelles avec les outils en travaillant sur la batterie.
- Ne pas utiliser le poste de soudage pour charger les batteries ou des véhicules de démarrage rapide.
- Observer la polarité correcte (+ et -) sur les batteries.
- Débrancher le câble négatif (-) en premier lieu. Le rebrancher en dernier lieu.

- Seules des personnes qualifiées sont autorisées à enlever les portes, panneaux, recouvrements ou dispositifs de protection pour effectuer, s'il y a lieu, des travaux d'entretien et de dépannage.
- Pour empêcher tout démarrage accidentel pendant les travaux d'entretien, débrancher le câble négatif (-) de batterie de la borne.
- Ne pas approcher les mains, cheveux, vêtements lâches et outils des organes mobiles.
- Remettre en place les panneaux ou les dispositifs de protection et fermer les portes à la fin des travaux d'entretien et avant de faire démarrer le moteur.
- Avant d'intervenir, déposer les bougies ou injecteurs pour éviter la mise en route accidentelle du moteur.
- Bloquer le volant moteur pour éviter sa rotation lors d'une intervention sur le générateur.



LE CARBURANT MOTEUR peut provoquer un incendie ou une explosion.

- Arrêter le moteur avant de vérifier le niveau de carburant ou de faire le plein.
- Ne pas faire le plein en fumant ou proche d'une source d'étincelles ou d'une flamme nue.
- Ne pas faire le plein de carburant à ras bord; prévoir de l'espace pour son expansion.
- Faire attention de ne pas renverser de carburant. Nettoyer tout carburant renversé avant de faire démarrer le moteur.
- Jeter les chiffons dans un récipient ignifuge.
- Toujours garder le pistolet en contact avec le réservoir lors du remplissage.



DES PIÈCES CHAUDES peuvent provoquer des brûlures graves.

- Ne pas toucher à mains nues les parties chaudes.
- Prévoir une période de refroidissement avant de travailler à l'équipement.
- Ne pas toucher aux pièces chaudes, utiliser les outils recommandés et porter des gants de soudage et des vêtements épais pour éviter les brûlures.

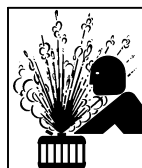

LA VAPEUR ET LE LIQUIDE DE REFROIDISSEMENT CHAUD peuvent provoquer des brûlures.

- Il est préférable de vérifier le liquide de refroidissement une fois le moteur refroidi pour éviter de se brûler.
- Toujours vérifier le niveau de liquide de refroidissement dans le vase d'expansion (si présent), et non dans le radiateur (sauf si précisé autrement dans la section maintenance du manuel du moteur).
- Si le moteur est chaud et que le liquide doit être vérifié, opérer comme suivant.
- Mettre des lunettes de sécurité et des gants, placer un torchon sur le bouchon du radiateur.
- Dévisser le bouchon légèrement et laisser la vapeur s'échapper avant d'enlever le bouchon.



DES ORGANES MOBILES peuvent provoquer des blessures.

- Ne pas approcher les mains des ventilateurs, courroies et autres pièces en mouvement.
- Maintenir fermés et fixement en place les portes, panneaux, recouvrements et dispositifs de protection.
- Arrêter le moteur avant d'installer ou brancher l'appareil.



L'utilisation d'un groupe autonome à l'intérieur PEUT VOUS TUER EN QUELQUES MINUTES.

- Les fumées d'un groupe autonome contient du monoxyde de carbone. C'est un poison invisible et inodore.
- JAMAIS utiliser dans une maison ou garage, même avec les portes et fenêtres ouvertes.
- Uniquement utiliser à l'EXTERIEUR, loin des portes, fenêtres et bouches aération.



L'ACIDE DE LA BATTERIE peut provoquer des brûlures dans les YEUX et sur la PEAU.

- Ne pas renverser la batterie.
- Remplacer une batterie endommagée.
- Rincer immédiatement les yeux et la peau à l'eau.



LA CHALEUR DU MOTEUR peut provoquer un incendie.

- Ne pas placer l'appareil sur, au-dessus ou à proximité de surfaces inflammables.
- Tenir à distance les produits inflammables de l'échappement.



LES ÉTINCELLES À L'ÉCHAPPEMENT peuvent provoquer un incendie.

- Empêcher les étincelles d'échappement du moteur de provoquer un incendie.
- Utiliser uniquement un pare-étincelles approuvé – voir codes en vigueur.

2-4. Dangers liés à l'air comprimé



RESPIRER L'AIR COMPRIMÉ peut provoquer des blessures graves ou causer la mort.

- Ne pas utiliser l'air comprimé pour respirer.
- Utiliser l'air comprimé seulement pour le coupage, gougeage et les outils pneumatiques.

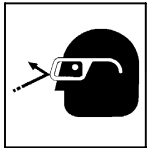

L'AIR COMPRIMÉ peut provoquer des blessures.

- Porter des lunettes de sécurité approuvées.
- Ne pas diriger le jet d'air vers d'autres ou soi-même.

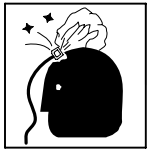

L'AIR COMPRIE EMMAGASINE ET DES TUYAUX SOUS PRESSON peuvent provoquer des blessures.

- Relâcher la pression d'air de l'outillage ou du système avant d'effectuer la maintenance, avant de changer ou de rajouter des éléments ou avant d'ouvrir la purge ou le bouchon de remplissage d'huile.



Le METAL CHAUD lors du coupage et gougeage plasma peut provoquer un incendie ou une explosion.

- Ne pas couper ou gouger à proximité de produits inflammables.
- Surveillez et garder un extincteur à proximité.



DES PIÈCES CHAUDES peuvent provoquer des brûlures et blessures.

- Ne pas toucher le compresseur ou d'autres éléments du circuit air comprimé chauds.
- Laisser l'ensemble se refroidir avant de toucher ou d'effectuer la maintenance.

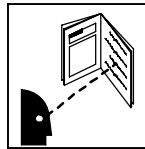

LIRE LES INSTRUCTIONS.

- Lisez le manuel d'instructions avant l'utilisation ou la maintenance de l'appareil.
- Arrêter le moteur et relâcher la pression avant d'effectuer la maintenance.
- N'utiliser que les pièces de rechange recommandées par le constructeur.

2-5. Dangers supplémentaires en relation avec l'installation, le fonctionnement et la maintenance



Risque D'INCENDIE OU D'EXPLOSION.

- Ne pas placer l'appareil sur, au-dessus ou à proximité de surfaces inflammables.
- Ne pas installer l'appareil à proximité de produits inflammables.
- Ne pas surcharger l'installation électrique – s'assurer que l'alimentation est correctement dimensionnée et protégée avant de mettre l'appareil en service.

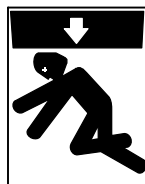

LA CHUTE DE L'APPAREIL peut blesser.

- Utiliser l'anneau de levage pour lever l'appareil et les accessoires correctement installés seuls, PAS les bouteilles de gaz. Ne pas dépasser le poids nominal maximal de l'ocillon (voir les spécifications).
- Ne lever et ne soutenir l'appareil qu'avec de l'équipement approprié et en suivant les procédures adéquates.
- En utilisant des fourches de levage pour déplacer l'unité, s'assurer que les fourches sont suffisamment longues pour dépasser du côté opposé de l'appareil.

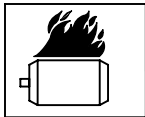

LE SURCHAUFFEMENT peut endommager le moteur électrique.

- Arrêter ou déconnecter l'équipement avant de démarrer ou d'arrêter le moteur.
- Ne pas laisser tourner le moteur trop lentement sous risque d'endommager le moteur électrique à cause d'une tension et d'une fréquence trop faibles.
- Ne pas brancher de moteur de 50 ou de 60 Hz à la prise de 100 Hz, s'il y a lieu.

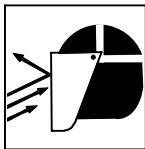

LES ÉTINCELLES VOLANTES risquent de provoquer des blessures.

- Porter un écran facial pour protéger le visage et les yeux.
- Affûter l'électrode au tungstène uniquement à la meuleuse dotée de protecteurs. Cette manœuvre est à exécuter dans un endroit sûr lorsque l'on porte l'équipement homologué de protection du visage, des mains et du corps.
- Les étincelles risquent de causer un incendie – éloigner toute substance inflammable.

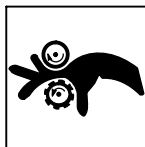

DES ORGANES MOBILES peuvent provoquer des blessures.

- Ne pas s'approcher des organes mobiles.
- Ne pas s'approcher des points de coincement tels que des rouleaux de commande.



LES FILS DE SOUDAGE peuvent provoquer des blessures.

- Ne pas appuyer sur la gâchette avant d'en avoir reçu l'instruction.
- Ne pas diriger le pistolet vers soi, d'autres personnes ou toute pièce mécanique en engageant le fil de soudage.

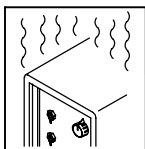

L'EMPLOI EXCESSIF peut SURCHAUFFER L'ÉQUIPEMENT.

- Laisser l'équipement refroidir ; respecter le facteur de marche nominal.
- Réduire le courant ou le facteur de marche avant de poursuivre le soudage.
- Ne pas obstruer les passages d'air du poste.

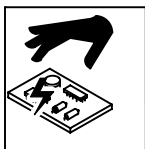

LES CHARGES ÉLECTROSTATIQUES peuvent endommager les circuits imprimés.

- Établir la connexion avec la barrette de terre avant de manipuler des cartes ou des pièces.
- Utiliser des pochettes et des boîtes antistatiques pour stocker, déplacer ou expédier des cartes de circuits imprimés.



UNE REMORQUE QUI BASCULE peut entraîner des blessures.

- Utiliser les supports de la remorque ou des blocs pour soutenir le poids.
- Installer convenablement le poste sur la remorque comme indiqué dans le manuel s'y rapportant.

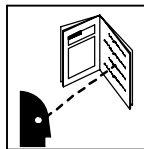

LIRE LES INSTRUCTIONS.

- Lisez le manuel d'instructions avant l'utilisation ou la maintenance de l'appareil.
- N'utiliser que les pièces de rechange recommandées par le constructeur.
- Effectuer la maintenance et le service du moteur et du compresseur d'air suivant les instructions dans ce manuel ou le manuel du moteur/compresseur (si applicable).

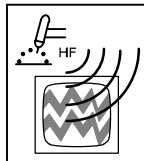

LE RAYONNEMENT HAUTE FRÉQUENCE (H.F.) risque de provoquer des interférences.

- Le rayonnement haute fréquence (H.F.) peut provoquer des interférences avec les équipements de radio-navigation et de communication, les services de sécurité et les ordinateurs.
- Demander seulement à des personnes qualifiées familiarisées avec des équipements électroniques de faire fonctionner l'installation.
- L'utilisateur est tenu de faire corriger rapidement par un électricien qualifié les interférences résultant de l'installation.
- Si le FCC signale des interférences, arrêter immédiatement l'appareil.
- Effectuer régulièrement le contrôle et l'entretien de l'installation.
- Maintenir soigneusement fermés les portes et les panneaux des sources de haute fréquence, maintenir les éclateurs à une distance correcte et utiliser une terre et un blindage pour réduire les interférences éventuelles.

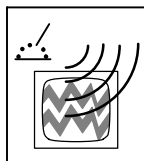

LE SOUDAGE À L'ARC risque de provoquer des interférences.

- L'énergie électromagnétique risque de provoquer des interférences pour l'équipement électronique sensible tel que les ordinateurs et l'équipement commandé par ordinateur tel que les robots.
- Veiller à ce que tout l'équipement de la zone de soudage soit compatible électromagnétiquement.
- Pour réduire la possibilité d'interférence, maintenir les câbles de soudage aussi courts que possible, les grouper, et les poser aussi bas que possible (ex. par terre).
- Veiller à souder à une distance de 100 mètres de tout équipement électronique sensible.
- Veiller à ce que ce poste de soudage soit posé et mis à la terre conformément à ce mode d'emploi.
- En cas d'interférences après avoir pris les mesures précédentes, il incombe à l'utilisateur de prendre des mesures supplémentaires telles que le déplacement du poste, l'utilisation de câbles blindés, l'utilisation de filtres de ligne ou la pose de protecteurs dans la zone de travail.

2-6. Proposition californienne 65 Avertissements

! Les équipements de soudage et de coupage produisent des fumées et des gaz qui contiennent des produits chimiques dont l'État de Californie reconnaît qu'ils provoquent des malformations congénitales et, dans certains cas, des cancers. (Code de santé et de sécurité de Californie, chapitre 25249.5 et suivants)

! Les batteries, les bornes et autres accessoires contiennent du plomb et des composés à base de plomb, produits chimiques dont l'État de Californie reconnaît qu'ils provoquent des cancers et des malformations congénitales ou autres problèmes de procréation. Se laver les mains après manipulation.

Pour les moteurs à essence :

! Les gaz d'échappement des moteurs contiennent des produits chimiques dont l'État de Californie reconnaît qu'ils provoquent des cancers et des malformations congénitales ou autres problèmes de procréation.

Pour les moteurs diesel :

! Les gaz d'échappement des moteurs diesel et certains de leurs composants sont reconnus par l'État de Californie comme provoquant des cancers et des malformations congénitales ou autres problèmes de procréation.

2-7. Principales normes de sécurité

Safety in Welding, Cutting, and Allied Processes, ANSI Standard Z49.1, de Global Engineering Documents (téléphone : 1-877-413-5184, site Internet : www.global.ih.com).

Recommended Safe Practices for the Preparation for Welding and Cutting of Containers and Piping, American Welding Society Standard AWS F4.1 de Global Engineering Documents (téléphone : 1-877-413-5184, site Internet : www.global.ih.com).

National Electrical Code, NFPA Standard 70, de National Fire Protection Association, P.O. Box 9101, Quincy, MA 02269-9101 (téléphone : 617-770-3000, site Internet : www.nfpa.org).

Safe Handling of Compressed Gases in Cylinders, CGA Pamphlet P-1, de Compressed Gas Association, 4221 Walney Road, 5th Floor, Chantilly, VA 20151 (téléphone : 703-788-2700, site Internet : www.cganet.com).

Code for Safety in Welding and Cutting, CSA Standard W117.2, de Canadian Standards Association, 5060 Mississauga, Ontario, Canada

L4W 5NS (téléphone : 800-463-6727 ou à Toronto 416-747-4044, site Internet : www.csa-international.org).

Safe Practice For Occupational And Educational Eye And Face Protection, ANSI Standard Z87.1, de American National Standards Institute, 11 West 43rd Street, New York, NY 10036-8002 (téléphone : 212-642-4900, site Internet : www.ansi.org).

Standard for Fire Prevention During Welding, Cutting, and Other Hot Work, NFPA Standard 51B, de National Fire Protection Association, P.O. Box 9101, Quincy, MA 02269-9101 (téléphone : 617-770-3000, site Internet : www.nfpa.org).

OSHA, Occupational Safety and Health Standards for General Industry, Title 29, Code of Federal Regulations (CFR), Part 1910, Subpart Q, and Part 1926, Subpart J, de U.S. Government Printing Office, Superintendent of Documents, P.O. Box 371954, Pittsburgh, PA 15250-7954 (téléphone : 1-866-512-1800) (il y a 10 bureaux régionaux--le téléphone de la région 5, Chicago, est 312-353-2220, site Internet : www.osha.gov).

2-8. Information EMF

Considérations sur le soudage et les effets de basse fréquence et des champs magnétiques et électriques.

Le courant de soudage, pendant son passage dans les câbles de soudage, causera des champs électromagnétiques. Il y a eu et il y a encore un certain souci à propos de tels champs. Cependant, après avoir examiné plus de 500 études qui ont été faites pendant une période de recherche de 17 ans, un comité spécial ruban bleu du National Research Council a conclu : « L'accumulation de preuves, suivant le jugement du comité, n'a pas démontré que l'exposition aux champs magnétiques et champs électriques à haute fréquence représente un risque à la santé humaine ». Toutefois, des études sont toujours en cours et les preuves continuent à être examinées. En attendant que les conclusions finales de la recherche soient établies, il vous serait souhaitable de réduire votre exposition aux champs électromagnétiques pendant le soudage ou le coupage.

Pour réduire les champs magnétiques sur le poste de travail, appliquer les procédures suivantes :















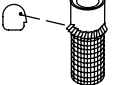







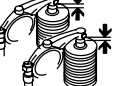













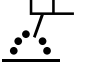





1. Garder les câbles ensemble, les torsader, les scotcher, ou les recouvrir d'une housse.
2. Disposer les câbles d'un côté et à distance de l'opérateur.
3. Ne pas courber pas et ne pas entourer pas les câbles autour de votre corps.
4. Garder le poste de soudage et les câbles le plus loin possible de vous.
5. Connecter la pince sur la pièce aussi près que possible de la soudure.

En ce qui concerne les implants médicaux :

Les porteurs d'implants doivent d'abord consulter leur médecin avant de s'approcher des opérations de soudage à l'arc, de soudage par points, de gougeage, du coupage plasma ou de chauffage par induction. Si le médecin approuve, il est recommandé de suivre les procédures précédentes.

SECTION 3 – DEFINITIONS

3-1. Symbols And Definitions

	Stop Engine		Fast (Run, Weld/Power)		Slow (Idle)		Start Engine
	Check engine belt		Check Air Cleaner		Starting Aid		Engine
	Battery (Engine)		Jump start/Battery Charge		Battery Charge		Jump Start
	Do Not Switch Under Load		Read Operator's Manual		Certified/Trained Mechanic		Engine Oil
	Check Injectors/Pump		Check Valve Clearance		Fuel		Engine Coolant Temperature
	Hourmeter (HM)		Air Pressure		Temperature		Air Compressor
	Positive		Negative		Wire Feed		Welding Arc
	Amperes		Volts		Panel/Local		Remote
	Output		Direct Current (DC)		Alternating Current (AC)		Gas Tungsten Arc Welding (TIG)
	Stick (SMAW) Welding		Constant Current (CC)		MIG (GMAW) Welding		Constant Voltage (CV)
	Three Phase		Single Phase		Air Carbon Arc Cutting (CAC-A)		Protective Earth (Ground)
	DC Electrode Positive		DC Electrode Negative		Work Connection		Electrode Connection
	Circuit Protector		Time		Hours		Seconds
	On		Off				

SECTION 4 – SPECIFICATIONS

4-1. Weld, Power, And Engine Specifications

Welding Mode	Weld Output Range	Rated Welding Output	Maximum Open-Circuit Voltage (Nominal)	Generator Power Rating	Engine	Engine Oil Capacity	Fuel Tank Capacity
CC/DC	20 – 750 A	500 A, 40 Volts DC, 100% Duty Cycle	95	Standard Single-Phase, 4 kVA/kW, 34/17 A, 120/240 V AC, 50/60 Hz 3-Phase Generator Option* Single-Phase/Three-Phase, 12/20 kVA/kW, 50/48A, 120/240 VAC, 60 Hz *In Addition To Standard 4 kVA/kW Generator Power	 Deutz BF4M2011 Oil-Cooled, Four-Cylinder, Turbo-Charged 63.4 HP Diesel Engine	11 qt (10.4 L)	25 gal (95 L)
CV/DC	14 – 40 V	600 A, 44 Volts DC, 40% Duty Cycle	56				
CC/AC (Optional)	20 - 575	750 A, 12 Volt Jump Start	64				
Battery Charge/ Jump Start	12/24 V	750 A, 24 Volt Jump Start	14/28				

4-2. Air Compressor Specifications

Compressor Model And Type	Air Output At Effective Working Pressure	Factory Pressure Setting	Safety Relief Valve Rating	Air Compressor Oil Capacity
Ingersoll Rand CE55 G Rotary Screw	60 scfm (1.7 m ³ min ⁻¹), 100 psi (690 kPa), 100% Duty Cycle	125 psi (862 kPa)	150 psi (1034 kPa)	4 qt (3.8 L)

4-3. Sound Level Table

	Idle Speed (1235 rpm)	Weld/Power Speed (1850 rpm)	40 Volts DC At 500 Amps	44 Volts DC At 600 Amps
Air Compressor On	96.6 Lwa sound power 71.7 dBA at 23 ft (7 m) 77.2 dBA 3.3 ft (1 m) from front panel	102.8 Lwa sound power 77.9 dBA at 23 ft (7 m) 83.0 dBA 3.3 ft (1 m) from front panel	103.9 Lwa sound power 79.0 dBA at 23 ft (7 m) 89.8 dBA 3.3 ft (1 m) from front panel	106.0 Lwa sound power 81.1 dBA at 23 ft (7 m) 93.3 dBA 3.3 ft (1 m) from front panel
Air Compressor Off	94.6 Lwa sound power 69.7 dBA at 23 ft (7 m) 74.5 dBA 3.3 ft (1 m) from front panel	100.6 Lwa sound power 75.7dBA at 23 ft (7 m) 78.8 dBA 3.3 ft (1 m) from front panel	103.0 Lwa sound power 78.1dBA at 23 ft (7 m) 86.0 dBA 3.3 ft (1 m) from front panel	104.5 Lwa sound power 79.6 dBA at 23 ft (7 m) 91.8 dBA 3.3 ft (1 m) from front panel

4-4. Dimensions, Weights, And Operating Angles

Dimensions	
Height	54-1/2 in (1384 mm) (to top of muffler)
Width	28-1/2 in (724 mm) (mtg. brackets turned in)
	30-3/4 in (781 mm) (mtg. brackets turned out)
Depth	69-1/2 in (1765 mm)
A	69-1/2 in (1765 mm)
B*	55-7/8 in (1419 mm)
C*	46-3/8 in (1178)
D*	11 in (279 mm)
E	27-1/2 in (699 mm)
F	1 in (25 mm)
G	29-13/16 in (757 mm)
H	9/16 in (14 mm) Dia. 4 Holes

* With mounting brackets in center position. Dimensions vary with location of mounting brackets.

Weight	
No fuel:	2010 lb (907 kg)
w/fuel:	2185 lb (993 kg)
Lifting Eye Weight Rating 2185 lb (993 kg) Maximum	

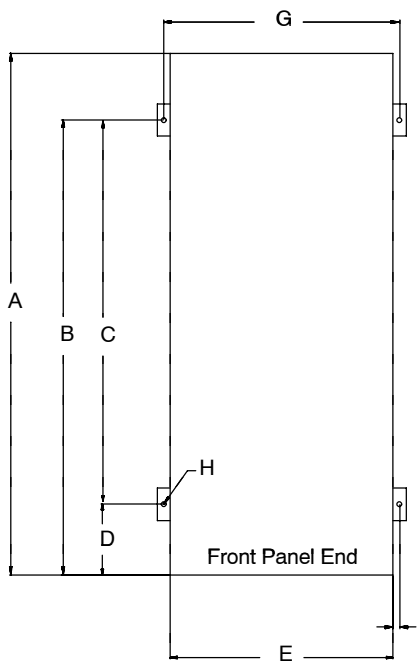

802 161-A



⚠ Do not exceed tilt angles or engine could be damaged or unit could tip.

⚠ Do not move or operate unit where it could tip.

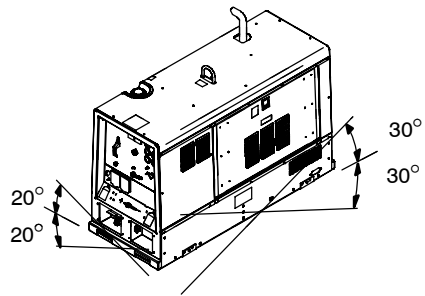

803 231

Notes

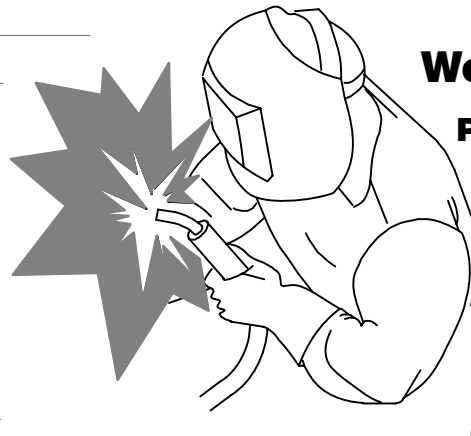

Work like a Pro!

Pros weld and cut safely. Read the safety rules at the beginning of this manual.

4-5. Stick And MIG Volt-Ampere Curves

A. DC Stick Mode

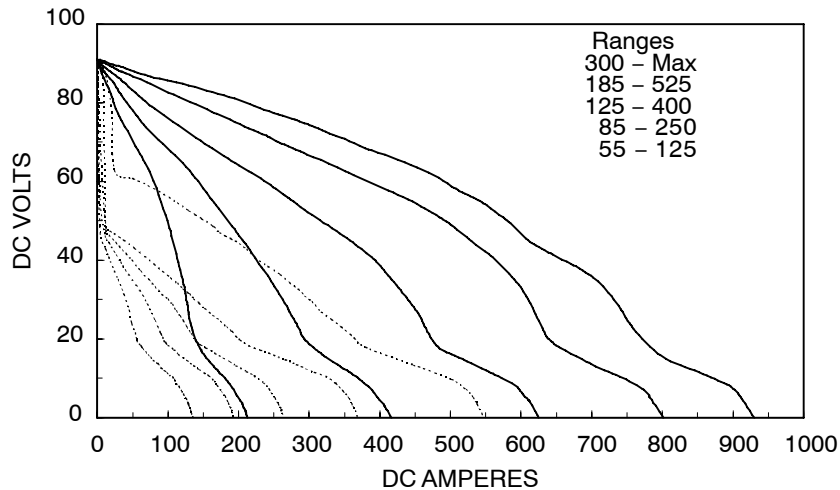

The volt-ampere curve shows the minimum and maximum voltage and amperage output capabilities of the welding generator. Curves of all other settings fall between the curves shown.

B. AC Stick Mode (Optional)

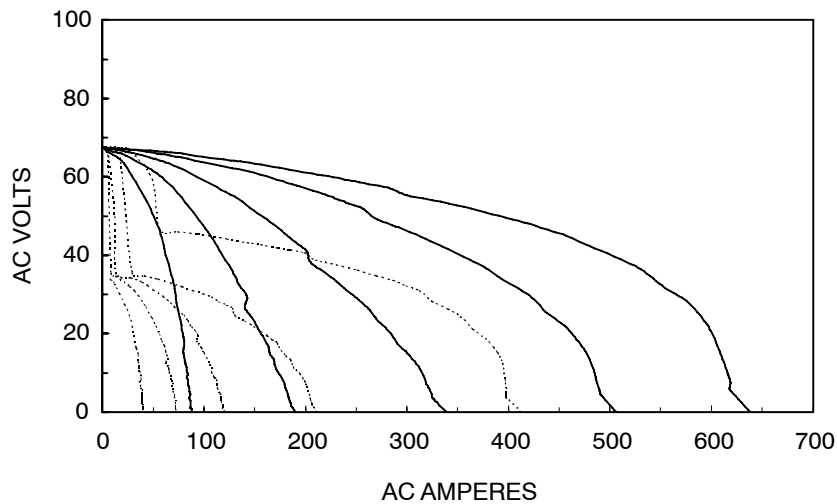

C. MIG Mode

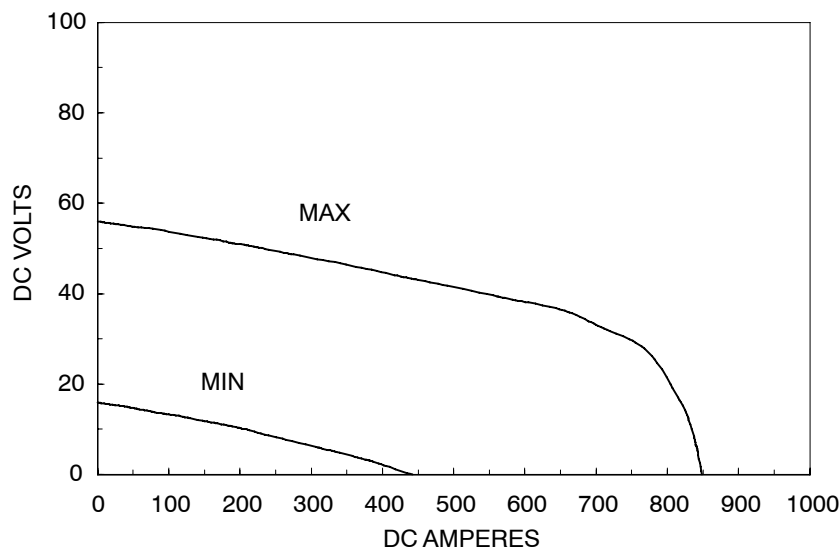

4-6. TIG Volt-Ampere Curves

The volt-ampere curve shows the minimum and maximum voltage and amperage output capabilities of the welding generator. Curves of all other settings fall between the curves shown.

A. DC TIG Mode

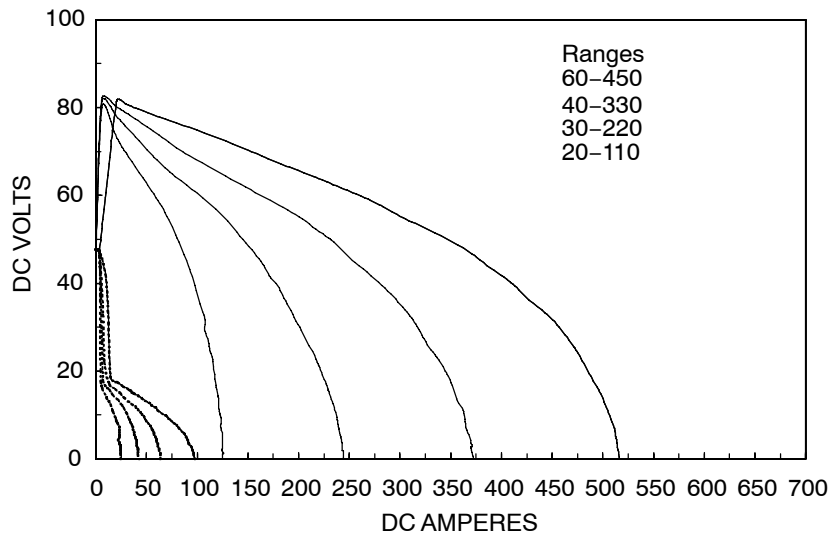

B. AC TIG Mode (Optional)

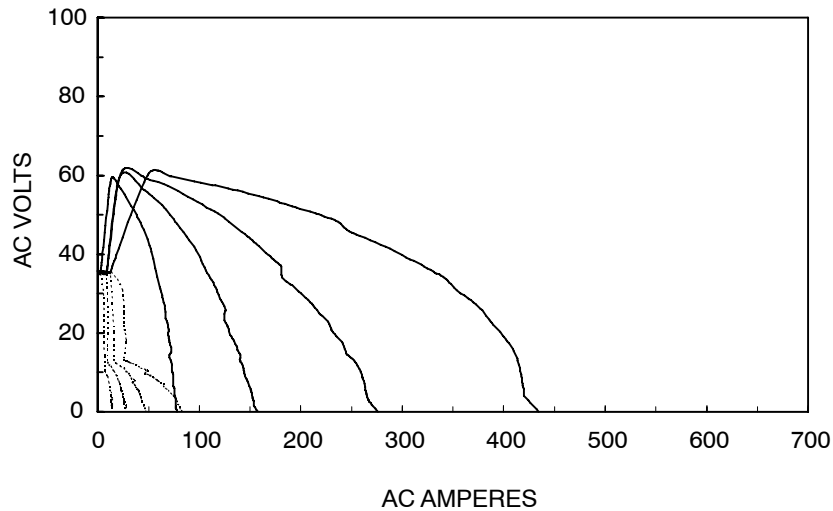

4-7. Fuel Consumption

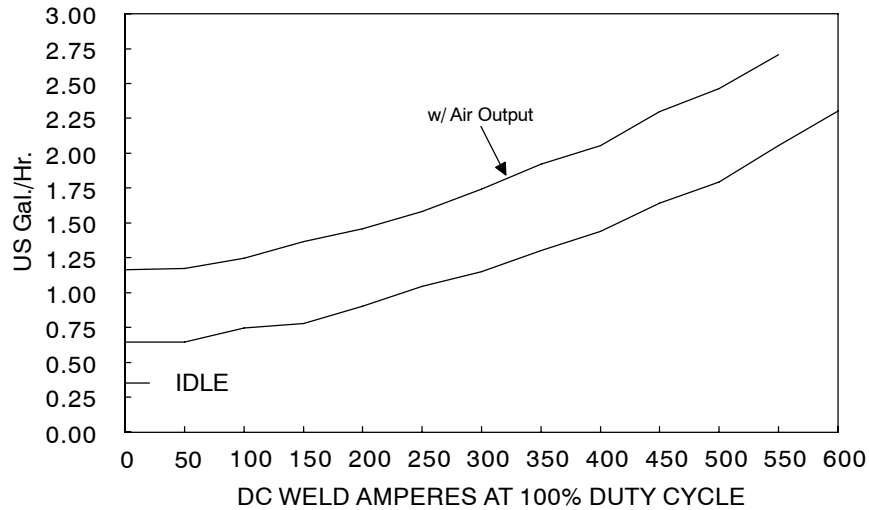

The curve shows typical fuel use under weld or generator power loads.

208 211

4-8. Duty Cycle And Overheating



100% Duty Cycle At 500 Amperes



Continuous Welding

40% Duty Cycle At 600 Amperes

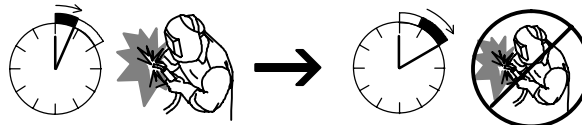

4 Minutes Welding

6 Minutes Resting

Duty Cycle is percentage of 10 minutes that unit can weld at rated load without overheating.

NOTICE - Exceeding duty cycle can damage unit and void warranty.

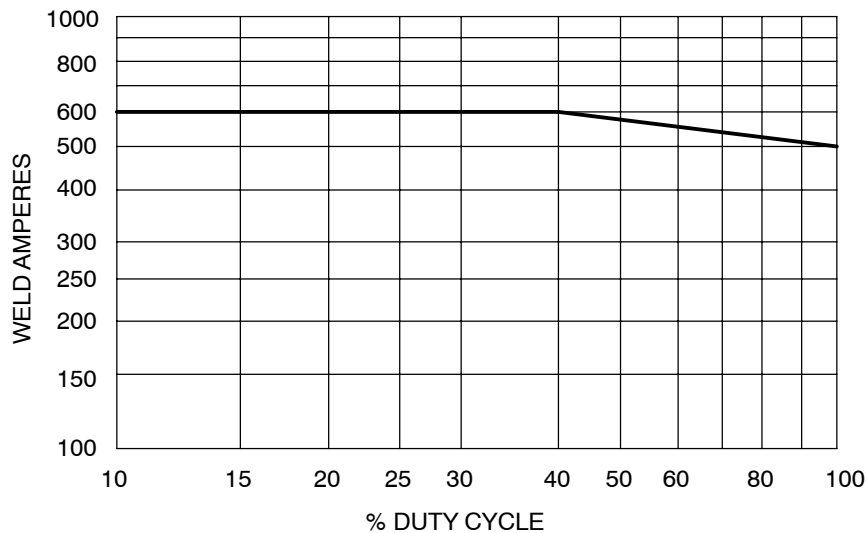

202 356

4-9. Generator AC Power Curve

The ac power curve shows the generator power in amperes available at the 120 and 240 volt receptacles.

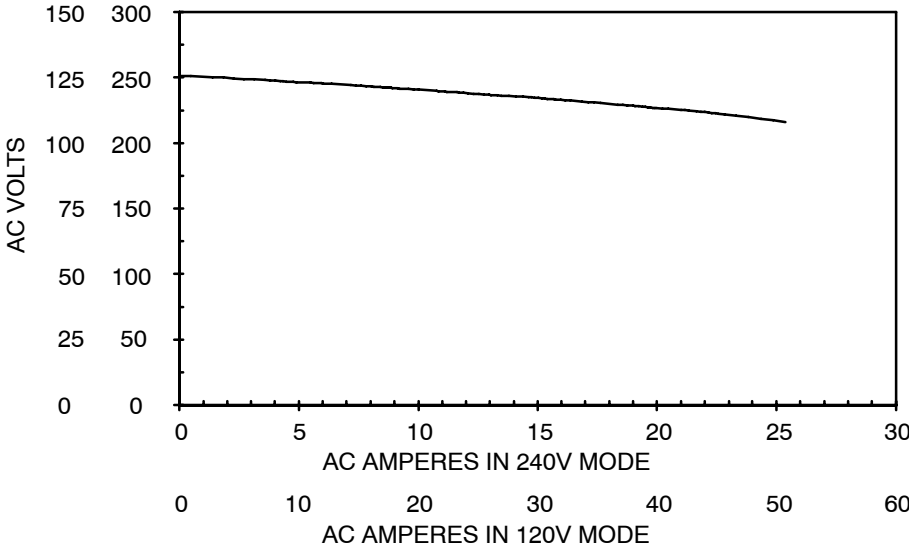

Notes

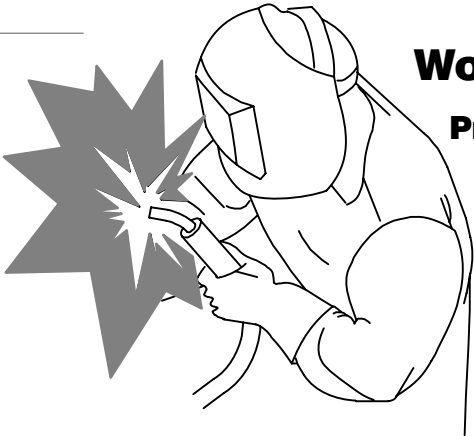

Work like a Pro!
Pros weld and cut safely. Read the safety rules at the beginning of this manual.

4-10. Optional 3-Phase Generator Power Curves

The ac power curves show the generator power available in amperes at the single-phase 120/240 volt receptacle or three-phase 240 volt terminals.

A. 12 kVA/kW Single-Phase AC Output (No Weld Load)

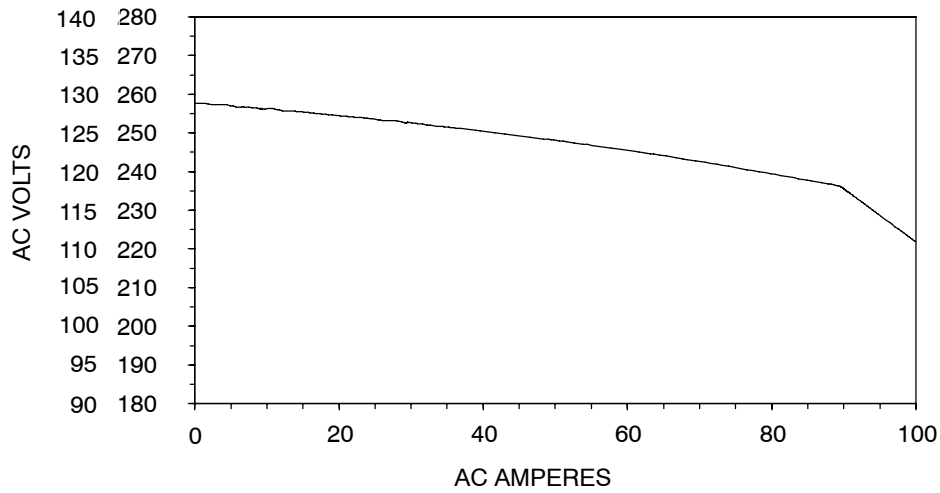

B. 20 kVA/kW Three-Phase AC Output (No Weld Load)

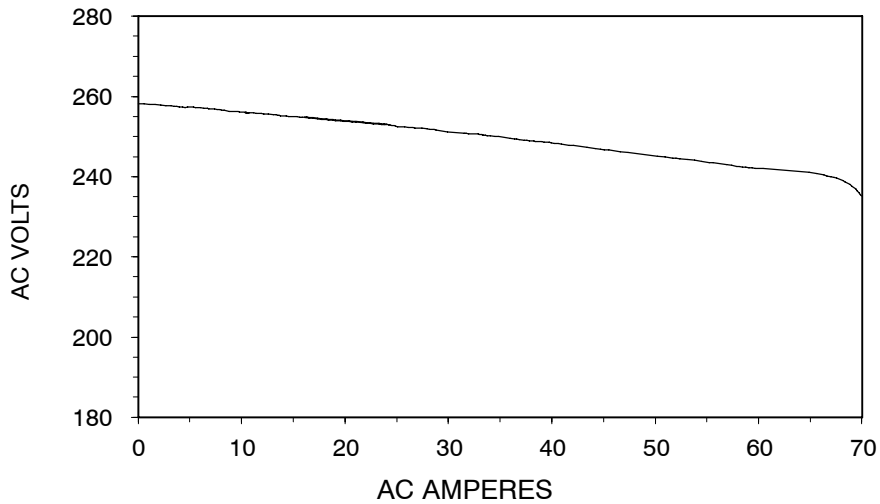

4-11. Air Compressor Output Curve

The air output curve shows the volume and pressure of air available from the air compressor.

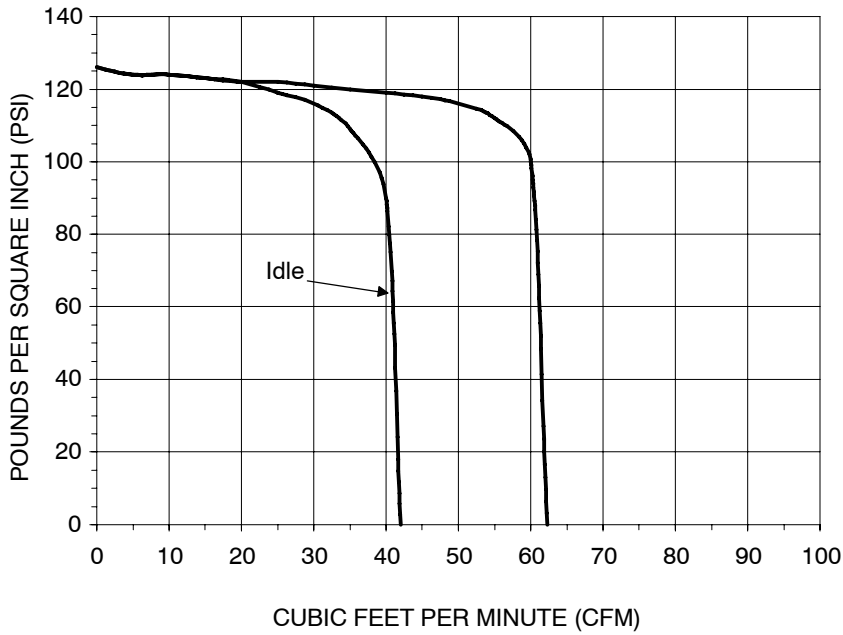

208 955

4-12. Optional Battery Charging Output Curve





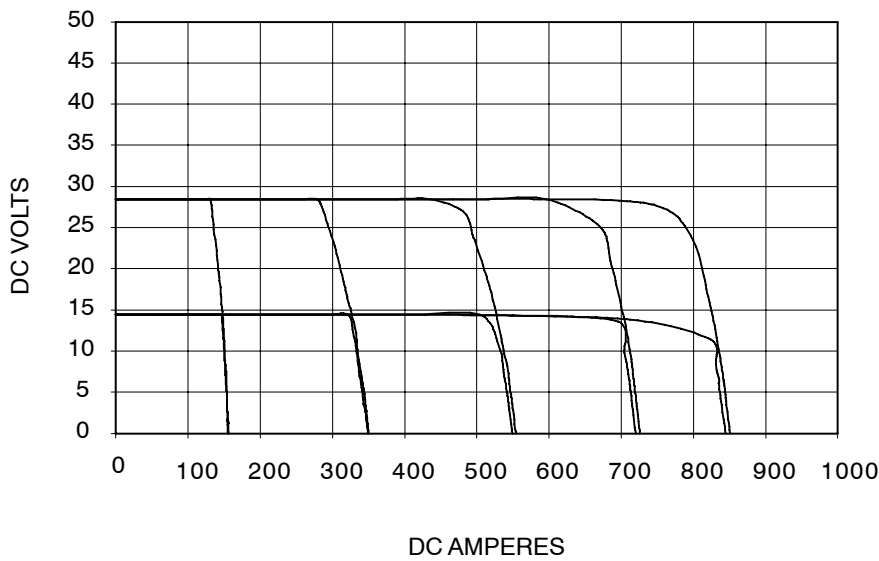











The battery charging curves show the charging amperage and voltage output of the welding generator.

As battery voltage nears the charging voltage, charging current decreases.



210 269

4-13. Manufacturing Rating Label

  		BIG BLUE AIR PAK					
		45A/22V		to		600A/44V	
		X	40%	60%	100%		
		I_2	600A	550A	500A		
	$U_0 = 91V$	U_2	44V	42V	40V		
		20A/11V		to		450A/28V	
		X			100%		
		I_2			450A		
	$U_0 = 48V$	U_2			28V		
		20A/15V		to		500A/40V	
		X			100%		
		I_2			500A		
	$U_0 = 56V$	U_2			40V		
		35A/21V		to		450A/38V	
		X	40%	60%	100%		
		I_2	450A	425A	400A		
	$U_0 = 64V$	U_2	38V	37V	36V		
		20A/11V		to		375A/25V	
		X			100%		
		I_2			375A		
	$U_0 = 34V$	U_2			25V		
		10A/14V		to		750A/28V	
		X	25%		100%		
		I_2	750A		500A		
	$U_0 = 28V$	U_2	12/24V		12/24V		
	100psi	60cfm					
	n = 1800 min ⁻¹						
	n ₀ = 1850 min ⁻¹	*n ₁ = 1235 min ⁻¹		IP 23			
1 ~ 60 Hz	120/240V	4kVA	20/17A				
*1 ~ 60 Hz	120/240V	12kw	50/50A				
*3 ~ 60 Hz	240V	20kw	48A				
*Optional			208 483-C				

SECTION 5 – INSTALLATION

5-1. Installing Welding Generator

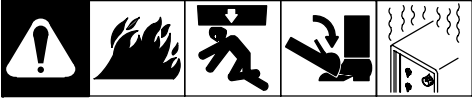

Movement

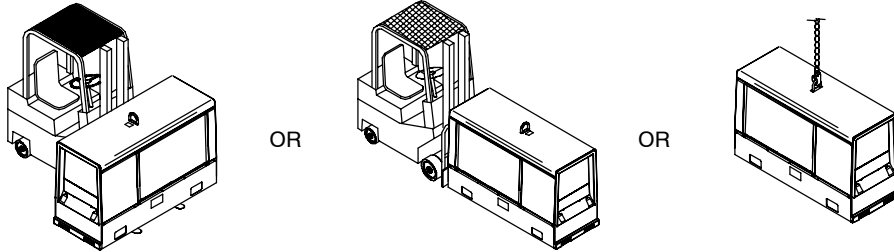

⚠ Always securely fasten welding generator onto transport vehicle or trailer and comply with all DOT and other applicable codes.

⚠ Always ground generator frame to vehicle frame to prevent electric shock and static electricity hazards.

⚠ If unit does not have GFCI receptacles, use GFCI-protected extension cord.

NOTICE – Do not install unit where air flow is restricted or engine may overheat.

Location/Airflow Clearance

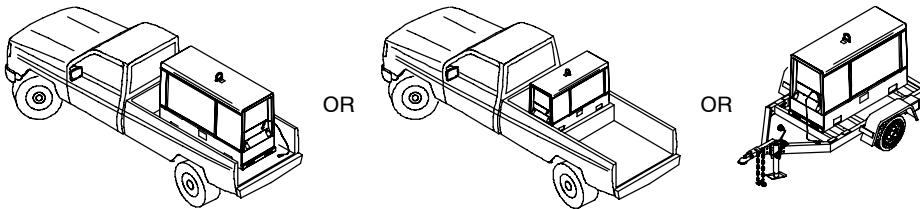

☞ See Section 4-4 for lifting eye rating.

☞ See Section 5-2 for mounting information.

Grounding:

- 1 Equipment Grounding Terminal (On Front Panel)
- 2 Grounding Cable (Not Supplied)
- 3 Metal Vehicle Frame

Connect cable from equipment ground terminal to metal vehicle frame. Use #10 AWG or larger insulated copper wire.

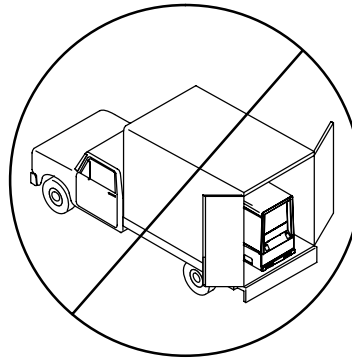
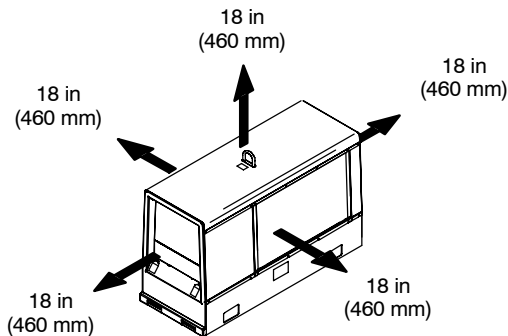

Grounding

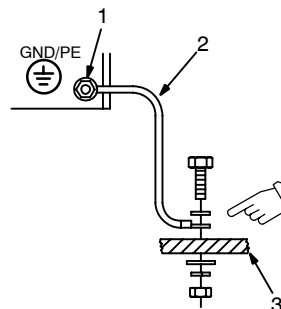

Electrically bond generator frame to vehicle frame by metal-to-metal contact.

⚠ Bed liners, shipping skids, and some running gears insulate the welding generator from the vehicle frame. Always connect a ground wire from the generator equipment grounding terminal to bare metal on the vehicle frame as shown.

5-2. Mounting Welding Generator



Supporting The Unit

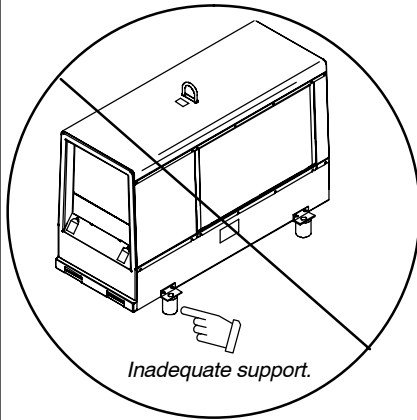

⚠ Do not use flexible mounts.

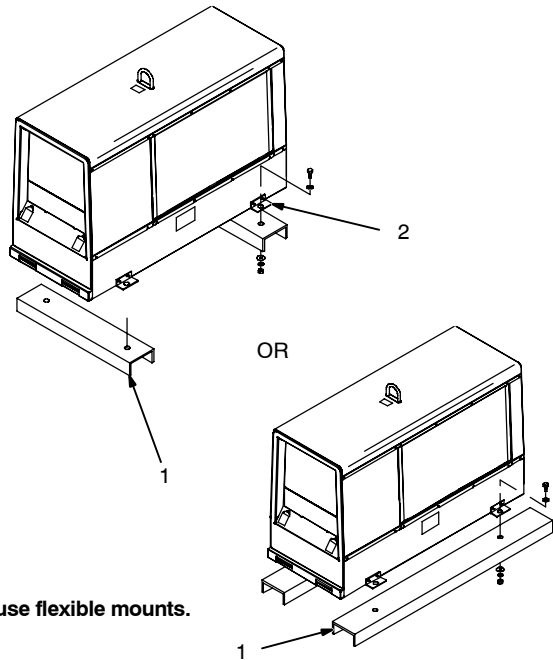

⚠ Do not weld on base. Welding on base can cause fuel tank fire or explosion. Weld only on the four mounting brackets or bolt unit down.

⚠ Do not mount unit by supporting the base only at the four mounting brackets. Use cross-supports to adequately support unit and prevent damage to base.

Mounting Surface:

- 1 Cross-Supports
- 2 Mounting Brackets (Supplied)

Mount unit on flat surface or use cross-supports to support base. Secure unit with mounting brackets.

- 3 1/2 in Bolt And Washer (Minimum – Not Supplied)
- 4 3/8-16 x 1 in Screws (Supplied)

To Bolt Unit In Place:

Remove hardware securing the four mounting brackets to the base. Reverse brackets and reattach to base with original hardware.

Mount unit to truck or trailer with 1/2 in (12 mm) or larger hardware (not supplied).

To Weld Unit In Place:

Weld unit to truck or trailer only at the four mounting brackets.

Using Mounting Brackets

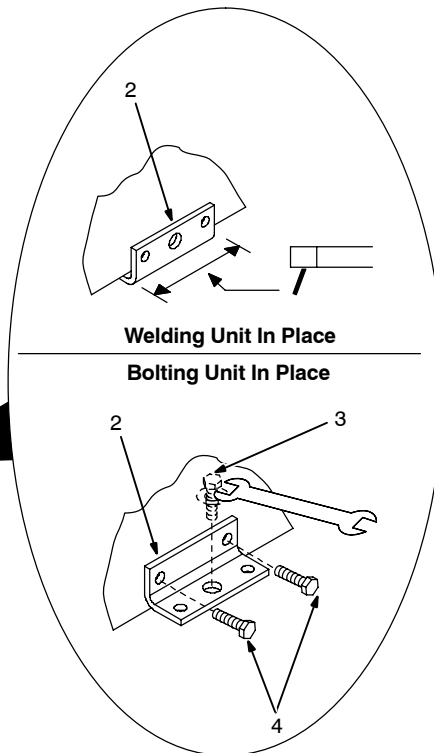
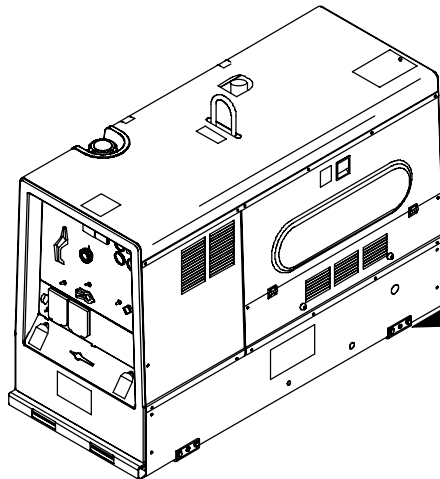

Tools Needed:

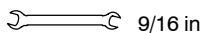

9/16 in

install3 8/06 803 274 / 200 864-A / 803 602

5-3. Installing Optional Spark Arrestor Muffler

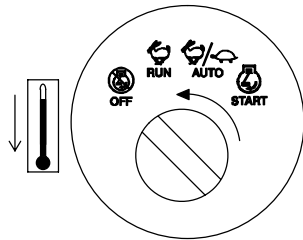

⚠ Stop engine and let cool.

- 1 Spark Arrestor Muffler
- 2 Double-Flanged Elbow
- 3 Nut
- 4 Flat Washer
- 5 Mount
- 6 Bracket
- 7 Screw
- 8 Single-Flanged Elbow
- 9 Rain Cap
- 10 Clamp

Loosely assemble components as shown.

☞ Mount the muffler with the clean-out plug to the outside.

After assembly, final-tighten all clamps and hardware.

☞ Be sure to tighten rain cap mounting screw.

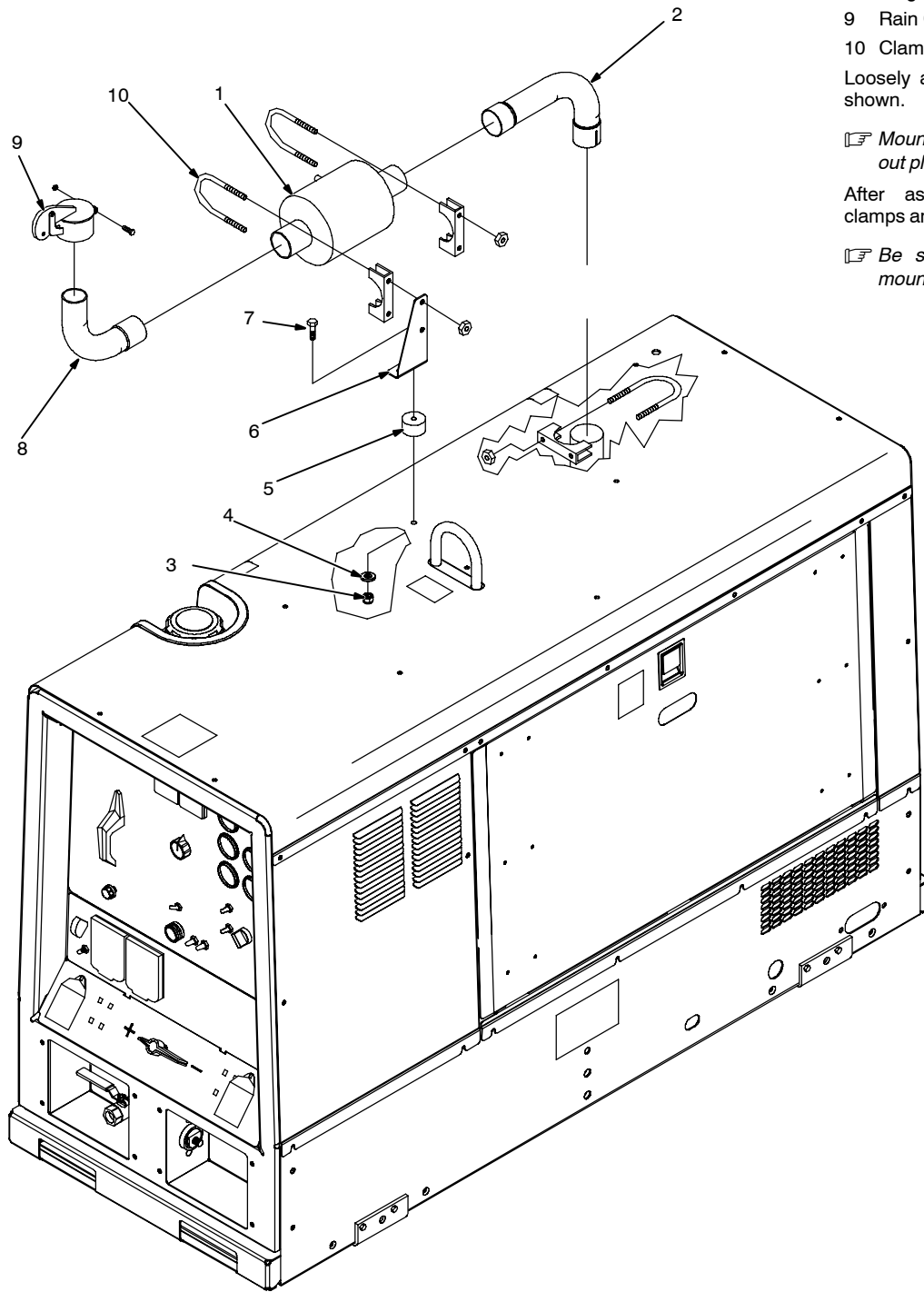

Tools Needed:



803 230

5-4. Activating The Dry Charge Battery (If Applicable)

1 Vent Caps

2 Sulfuric Acid Electrolyte (1.265 Specific Gravity)

3 Well

4 Battery Charger

5 A For 30 Minutes
OR
30 A For 12 Minutes

Tools Needed:

⚠ Always wear a face shield, rubber gloves and protective clothing when working on a battery.

Remove battery from unit.

⚠ Do not overfill battery cells.

Wait ten minutes and check electrolyte level. If necessary, add electrolyte to raise to proper level. Reinstall vent caps.

⚠ Read and follow all instructions supplied with battery charger.

Charge battery for 12 minutes at 30 amperes or 30 minutes at 5 amperes. Disconnect charging cables and install battery.

☞ When electrolyte is low, add only distilled water to cells to maintain proper level.

drybatt1 6/05 - S-0886

5-5. Connecting The Battery

⚠ Connect Negative (-) Cable Last.

Tools Needed:
 1/2 in

☞ Reinstall cover after connecting battery.

802 168-E / Ref. 202 705 / 802 313 / S-0756-C

5-7. Engine/Compressor Prestart Checks

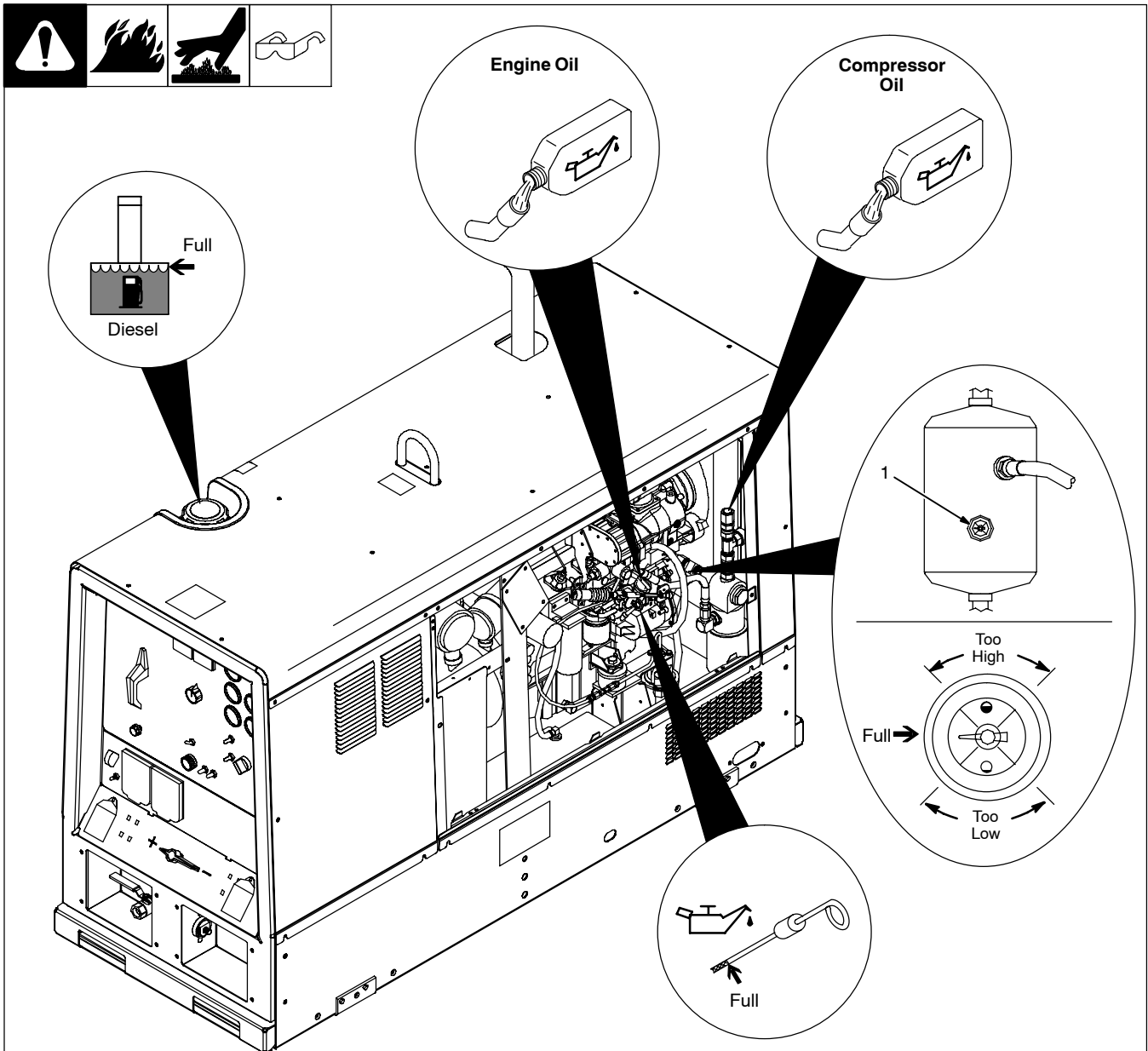

803 228

☞ Check all engine/compressor fluids daily.

Engine must be cold and on a level surface. Unit is shipped with 20W break-in oil. The automatic shutdown system stops engine if oil pressure is too low or coolant temperature is too high.

☞ This unit has a low oil pressure shutdown switch. However, some conditions may cause engine damage before the engine shuts down. Check oil level often and do not use the oil pressure shutdown system to monitor oil level.

Follow run-in procedure in engine manual. If unburned fuel and oil collect in exhaust pipe during run-in, see Section 14.

Fuel

NOTICE – Do not use gasoline. Gasoline will damage engine.

Add fresh diesel fuel before starting to prevent air from entering the fuel system (see engine maintenance label for fuel specifications). Leave filler neck empty to allow room for expansion.

Engine stops if fuel level is low on units with low fuel shutdown option. Do not run out of fuel or air may enter fuel system and cause starting problems. See engine manual to bleed air from fuel system.

Engine Oil

After fueling, check oil with unit on level surface. If oil is not up to full mark on dipstick, add oil (see maintenance label for engine oil specifications).

Compressor Oil

1 Compressor Oil Level Indicator (On Tank)

Check oil with unit on level surface. Add oil

if oil is not up to full mark on indicator (see maintenance label for oil specifications).

Cold Weather Starting

☞ To improve cold weather starting: Use Starting Aid switch (see Section 6-1).

Keep battery in good condition. Store battery in warm area.

Use fuel formulated for cold weather (diesel fuel can gel in cold weather). Contact local fuel supplier for fuel information.

Use correct grade oil for cold weather (see Section 9-1).

5-8. Connecting To Weld Output Terminals

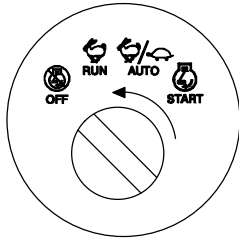

⚠ Stop engine.

- 1 Positive (+) Weld Output Terminal
- 2 Negative (-) Weld Output Terminal

⚠ Failure to properly connect weld cables may cause excessive heat and start a fire, or damage your machine.

- 3 Weld Output Terminal
- 4 Supplied Weld Output Terminal Nut
- 5 Weld Cable Terminal
- 6 Copper Bar

Remove supplied nut from weld output terminal. Slide weld cable terminal onto weld output terminal and secure with nut so that weld cable terminal is tight against copper bar. **Do not place anything between weld cable terminal and copper bar. Make sure that the surfaces of the weld cable terminal and copper bar are clean.**

Tools Needed:

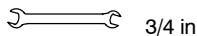

Stick And TIG Welding

For Stick welding Direct Current Electrode Positive (DCEP), connect electrode holder cable to Positive (+) terminal on left and work cable to Negative (-) terminal on right.

For Stick and TIG Direct Current Electrode Negative (DCEN), connect electrode holder cable to Negative (-) terminal on right and work cable to Positive (+) terminal on left.

If equipped with optional Polarity/AC Selector switch, connect electrode holder cable to Electrode terminal on left and work cable to Work terminal on right.

MIG And FCAW Welding

For MIG welding Direct Current Electrode Positive (DCEP), connect wire feeder cable to Positive (+) terminal on left and work cable to Negative (-) terminal on right. Use Process/Contactor switch to select type of weld output (see Section 6-3).

For MIG and FCAW Direct Current Electrode Negative (DCEN), connect wire feeder cable to Negative (-) terminal on right and work cable to Positive (+) terminal on left. Use Process/Contactor switch to select type of weld output (see Section 6-3).

If equipped with optional Polarity/AC Selector switch, connect wire feeder cable to Electrode terminal on left and work cable to Work terminal on right.

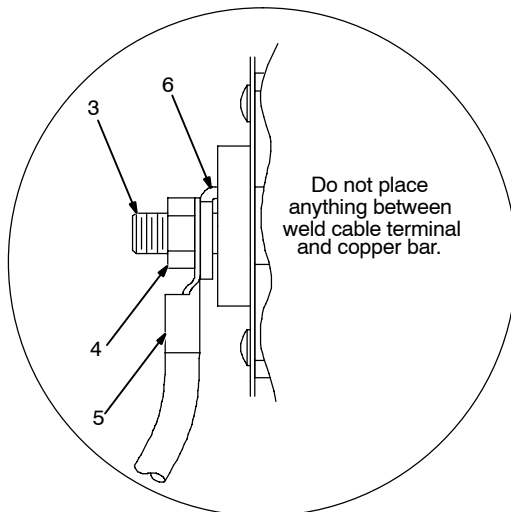
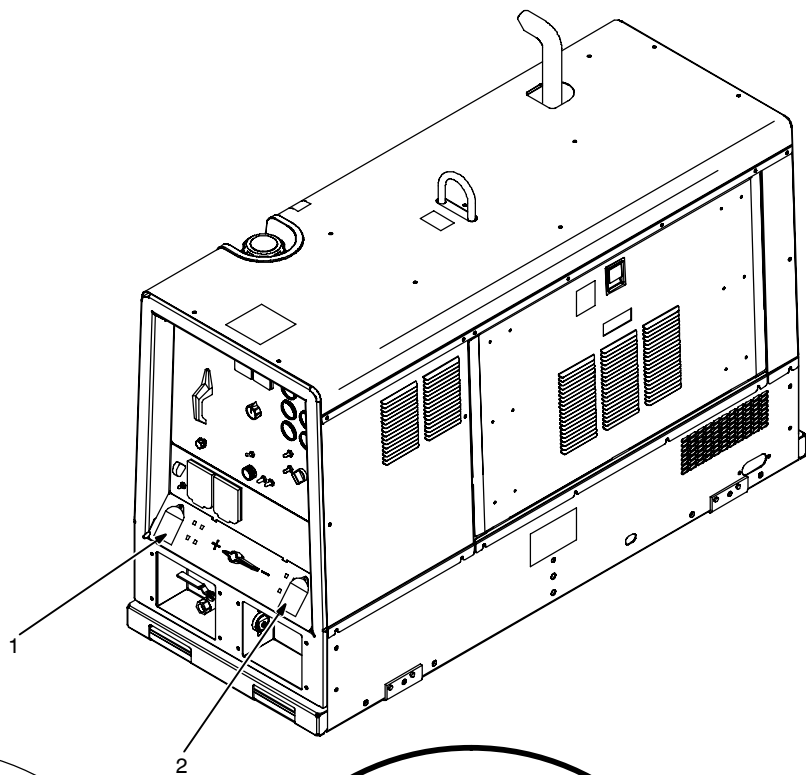

Correct Installation

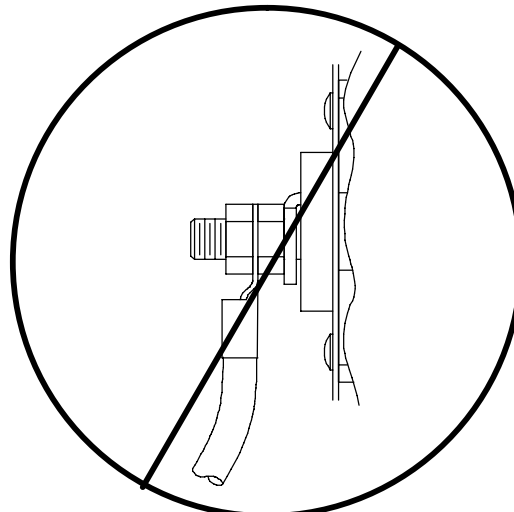

Incorrect Installation

Do not place anything between weld cable terminal and copper bar.

803 231 / 803 778-A

5-9. Selecting Weld Cable Sizes*

 <p>Weld Output Terminals</p> <p>⚠ Turn off power before connecting to weld output terminals.</p> <p>⚠ Do not use worn, damaged, undersized, or poorly spliced cables.</p>	Weld Cable Size** and Total Cable (Copper) Length in Weld Circuit Not Exceeding***								
	Welding Amperes	100 ft (30 m) or Less		150 ft (45 m)	200 ft (60 m)	250 ft (70 m)	300 ft (90 m)	350 ft (105 m)	400 ft (120 m)
		10 – 60% Duty Cycle	60 – 100% Duty Cycle	10 – 100% Duty Cycle					
100	4 (20)	4 (20)	4 (20)	3 (30)	2 (35)	1 (50)	1/0 (60)	1/0 (60)	
150	3 (30)	3 (30)	2 (35)	1 (50)	1/0 (60)	2/0 (70)	3/0 (95)	3/0 (95)	
200	3 (30)	2 (35)	1 (50)	1/0 (60)	2/0 (70)	3/0 (95)	4/0 (120)	4/0 (120)	
250	2 (35)	1 (50)	1/0 (60)	2/0 (70)	3/0 (95)	4/0 (120)	2 ea. 2/0 (2x70)	2 ea. 2/0 (2x70)	
300	1 (50)	1/0 (60)	2/0 (70)	3/0 (95)	4/0 (120)	2 ea. 2/0 (2x70)	2 ea. 3/0 (2x95)	2 ea. 3/0 (2x95)	
350	1/0 (60)	2/0 (70)	3/0 (95)	4/0 (120)	2 ea. 2/0 (2x70)	2 ea. 3/0 (2x95)	2 ea. 3/0 (2x95)	2 ea. 4/0 (2x120)	
400	1/0 (60)	2/0 (70)	3/0 (95)	4/0 (120)	2 ea. 2/0 (2x70)	2 ea. 3/0 (2x95)	2 ea. 4/0 (2x120)	2 ea. 4/0 (2x120)	
500	2/0 (70)	3/0 (95)	4/0 (120)	2 ea. 2/0 (2x70)	2 ea. 3/0 (2x95)	2 ea. 4/0 (2x120)	3 ea. 3/0 (3x95)	3 ea. 3/0 (3x95)	
600	3/0 (95)	4/0 (120)	2 ea. 2/0 (2x70)	2 ea. 3/0 (2x95)	2 ea. 4/0 (2x120)	3 ea. 3/0 (3x95)	3 ea. 4/0 (3x120)	3 ea. 4/0 (3x120)	
700	4/0 (120)	2 ea. 2/0 (2x70)	2 ea. 3/0 (2x95)	2 ea. 4/0 (2x120)	3 ea. 3/0 (3x95)	3 ea. 4/0 (3x120)	3 ea. 4/0 (3x120)	4 ea. 4/0 (4x120)	
800	4/0 (120)	2 ea. 2/0 (2x70)	2 ea. 3/0 (2x95)	2 ea. 4/0 (2x120)	3 ea. 4/0 (3x120)	3 ea. 4/0 (3x120)	4 ea. 4/0 (4x120)	4 ea. 4/0 (4x120)	

* This chart is a general guideline and may not suit all applications. If cable overheats, use next size larger cable.





**Weld cable size (AWG) is based on either a 4 volts or less drop or a current density of at least 300 circular mils per ampere.
() = mm² for metric use

***For distances longer than those shown in this guide, call a factory applications representative at 920-735-4505.

S-0007-F

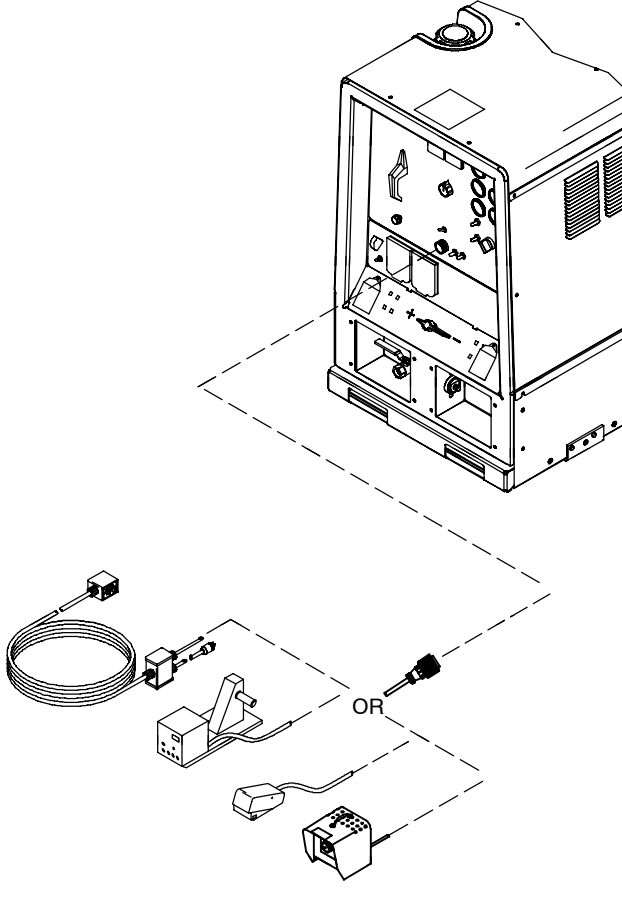
Notes

5-10. Connecting To Remote 14 Receptacle RC14

 <p style="text-align: right;">803 231</p>	 REMOTE 14	Socket*	Socket Information
	24 VOLTS AC  OUTPUT (CONTACTOR)	A	24 volts ac. Protected by supplementary protector CB5.
		B	Contact closure to A completes 24 volt ac contactor control circuit.
	REMOTE OUTPUT CONTROL	C	Output to remote control: +10 volts dc in MIG or Stick mode; 0 to +10 volts dc in TIG mode.
		D	Remote control circuit common.
		E	DC input command signal: 0 to +10 volts from min. to max. of remote control with Voltage/ Amperage Adjust control at max.
	115 VOLTS AC  OUTPUT (CONTACTOR)	I	115 volts, 10 amperes, 60 Hz ac. Protected by supplementary protector CB6.
		J	Contact closure to I completes 115 volt ac contactor control circuit.
GND	K	Chassis common.	
NEUTRAL	G	Circuit common for 24 and 115 volt ac circuit.	

*The remaining sockets are not used.

Notes

5-11. Connecting To The Air Compressor

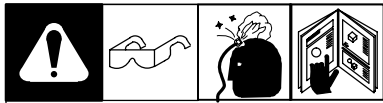

⚠ Stop engine and release air pressure before servicing compressor.

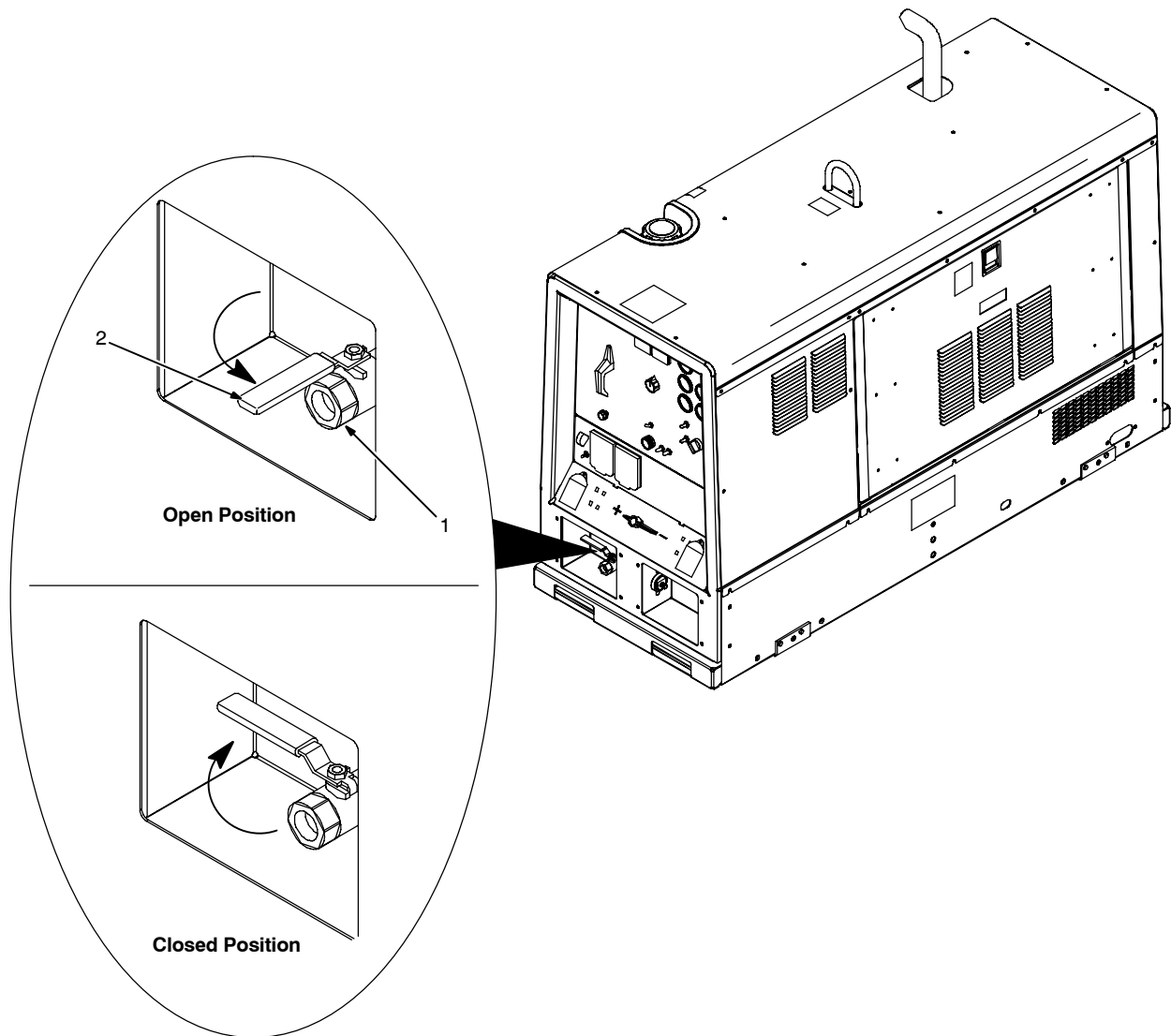

803 231

⚠ Air pressure is present at air shutoff valve whenever Air Pressure Gauge on front panel indicates air pressure.

- 1 3/4 in NPT Air Pressure Fitting
- 2 Air Shutoff Valve

Connect air hose with 3/4 in NPT fitting (not supplied) to air shutoff valve.

Be sure valve is in open position when using air compressor.

The compressor runs and air pressure is available whenever the engine is running and the front panel Compressor switch is moved to the On position (see Section 6-1).

Run engine at weld/power speed for maximum air compressor output. Compressor output is reduced when engine is running at idle speed.

The air compressor will not start if still under pressure. If air compressor is turned off, wait for air pressure to bleed off (about 20 seconds) before turning air compressor on again.

ⓘ *Using the air compressor does not significantly affect weld or generator power output.*

SECTION 6 – OPERATING THE WELDING GENERATOR

6-1. Controls (See Section 6-2)

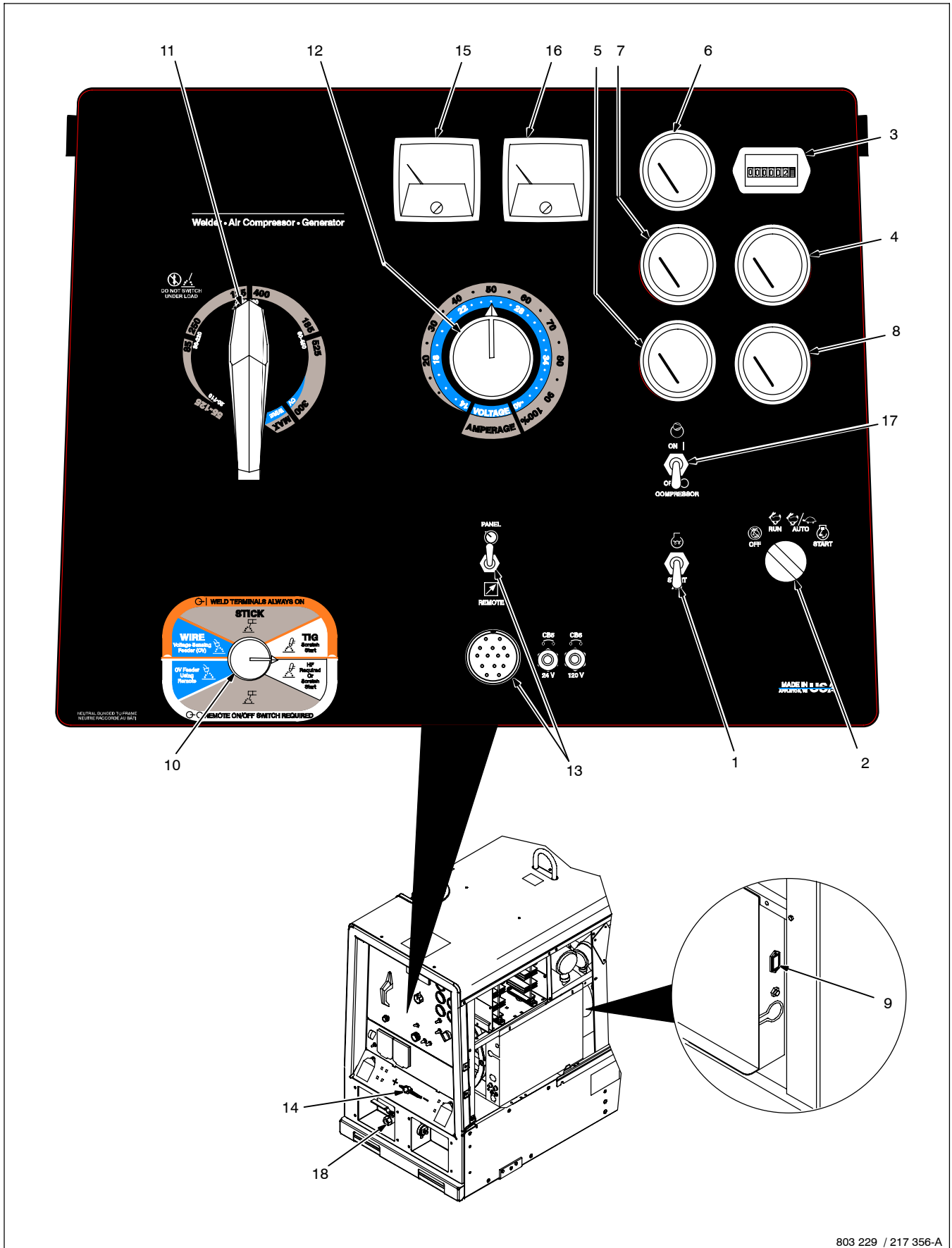

6-2. Description Of Controls (See Section 6-1)

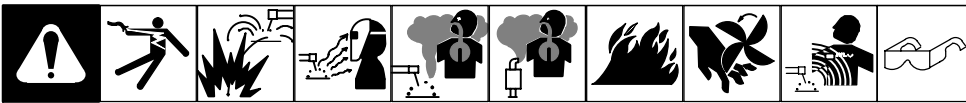

Engine Starting Controls

1 Starting Aid Switch

Use switch to energize starting aid for cold weather starting.

Push switch up for 60 seconds to operate the starting aid (intake air heater) before cranking engine (see starting instructions following).

2 Engine Control Switch

Use switch to start engine, select engine speed, and stop engine.

In Run position, engine runs at weld/power speed. In Run/Idle position, engine runs at idle speed with no generator power or weld load, and weld/power speed with load applied.

The air compressor load does not affect engine speed. Run engine at weld/power speed for maximum air compressor output.

To Start:

If engine does not start, let engine come to a complete stop before attempting re-start.

Above 32° F (0° C): turn Engine Control switch to Start. Release Engine Control switch when engine starts.

Below 32° F (0° C) using starting aid switch:

Turn Engine Control switch to Run/Idle position. Push Starting Aid switch up for 60 seconds. While still holding Starting Aid switch, turn Engine Control switch to Start. Release Engine Control switch and Starting Aid switch when engine starts.

To Stop: turn Engine Control switch to Off position.

Engine/Compressor Gauges

3 Engine Hour Meter

Use gauge to monitor engine running time for scheduling maintenance.

4 Fuel Gauge

Use gauge to check fuel level. Engine stops if fuel level is low on units with low fuel shutdown option.

To check fuel level when engine is not running, turn Engine Control switch to Run/Idle position.

5 Air Pressure Gauge

Use gauge to check compressor air pressure.

6 Engine Oil Pressure Gauge

Normal pressure is 30 – 60 psi (206 – 414 kPa). Engine stops if pressure is below 20 psi (138 kPa).

7 Engine Temperature Gauge

Normal temperature is 212 - 239° F (100 - 115° C). Engine stops if temperature exceeds 270° F (132° C).

8 Battery Voltmeter

Use gauge to check battery voltage and monitor the engine charging system. The meter should read about 14 volts dc when the engine is running, and about 12 volts dc when the engine is stopped.

9 Air Compressor Hour Meter (Optional)

Use gauge to monitor compressor running time for scheduling maintenance.

Weld Controls

10 Process/Contactor Switch

See Section 6-3 for Process/Contactor switch information.

11 Ampere Range Switch

NOTICE – Do not switch under load.

Use switch to select weld amperage range.

Use all five ranges for Stick welding, and the lowest four ranges for TIG welding. Read the upper set of numbers at each range for Stick welding and the lower set at each range for TIG welding.

Use the highest range for MIG welding and for cutting and gouging (CAC-A).

For most welding applications, use lowest amperage range possible to help prevent arc outages.

12 Voltage/Amperage Adjust Control

With Process/Contactor switch in any Stick or TIG setting, use control to adjust amperage within range selected by Ampere Range switch. With Process/Contactor switch in any MIG position, use control to adjust voltage. With Panel/Remote Switch in Remote position, control limits the remote amperage in TIG mode, but has no effect in Stick and MIG modes.

Weld output would be about 263 A DC with controls set as shown (50% of 125 to 400 A).

The numbers around the Voltage/Amperage Adjust control are for reference only

and do not represent an actual percentage value.

13 Panel/Remote Switch And Remote 14 Receptacle

Use switch to select front panel or remote voltage/amperage control. For remote control, place switch in Remote position and connect remote control to Remote 14 receptacle RC14 (see Sections 5-10 and 6-4).

14 Polarity/AC Selector Switch (Optional) Or Output Selector Switch (Optional)

NOTICE – Do not switch under load.

Use Polarity/AC selector switch to select AC or DC weld output and DC weld output polarity.

Use Output Selector switch to select AC Weld, DC Weld, or battery charge output (see Section 8-1).

Weld Meters

15 AC/DC Voltmeter (Optional)

Voltmeter displays voltage at the weld output terminals, but not necessarily the welding arc due to resistance of cable and connections.

16 AC/DC Ammeter (Optional)

Ammeter displays amperage output of the unit.

Air Compressor Controls

17 Air Compressor Switch

Use switch to turn air compressor on and off. Air pressure is present at the compressor air shutoff valve whenever the compressor is running. The compressor shuts off when the engine stops. To use air, the compressor must be turned on each time the engine is started.

The air compressor will not start if still under pressure. If air compressor is turned off, wait for air pressure to bleed off (about 20 seconds) before turning air compressor on again.

To extend clutch bearing life, cycle air compressor off and on once every two hours during periods of extended use.

18 Air Shutoff Valve

Air pressure is present at valve whenever Air Pressure Gauge (item 5) indicates air pressure.

Close valve to stop air flow when connecting or changing tools or air hoses (see Section 5-11).

6-3. Process/Contactor Switch

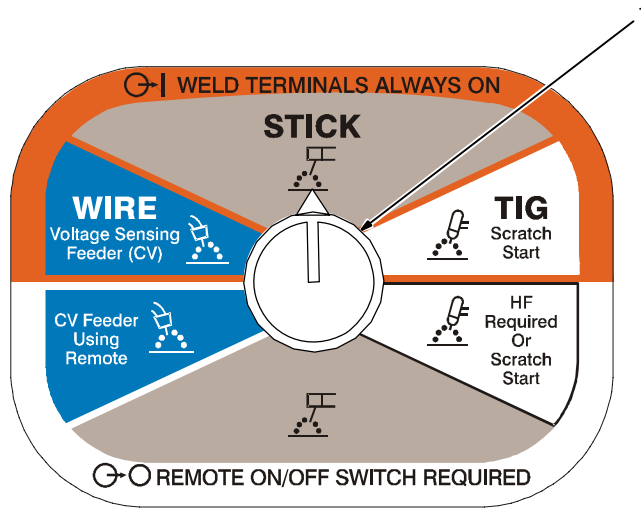

1 Process/Contactor Switch

⚠ Weld output terminals are energized when Process/Contactor switch is in a Weld Terminals Always On position and the engine is running.

⚠ DC voltage is still present at the weld terminals when Process/Contactor switch is in the Remote On/Off Switch Required – Stick position and the engine is running.

Use switch to select weld process and weld output on/off control (see table below and Section 6-4).

Place switch in Remote On/Off Switch Required positions to turn weld output on and off with a device connected to the remote 14 receptacle.

Place switch in Weld Terminals Always On positions for weld output to be on whenever the engine is running.

Use Stick position for air carbon arc (CAC-A) cutting and gouging.

When switch is in a Stick position, the arc drive (dig) circuit provides additional amperage during low voltage (short arc length conditions) to prevent “sticking” electrodes.

The arc drive (dig) circuit is disabled when switch is in MIG or TIG positions.

ℹ The engine auto idle option does not work in the Remote On/Off Switch Required-TIG mode.

217 356-A

Process/Contactor Switch Settings

Switch Setting	Process	Output On/Off Control	Engine Auto Idle (Optional)
Remote On/Off Switch Required – TIG, HF Required Or Scratch Start TIG	GTAW With HF Unit, Pulsing Device, Or Remote Control	At Remote 14 Receptacle	Not Active
Remote On/Off Switch Required – Stick	Stick (SMAW) With Remote On/Off	At Remote 14 Receptacle	Active
Remote On/Off Switch Required – CV Feeder Using Remote	MIG (GMAW)	At Remote 14 Receptacle	Active
Weld Terminals Always On – Wire	MIG (GMAW)	Electrode Hot	Active
Weld Terminals Always On – Stick	Stick (SMAW), Air Carbon Arc (CAC-A) Cutting And Gouging	Electrode Hot	Active
Weld Terminals Always On – TIG, Scratch Start	TIG Scratch Start (GTAW)	Electrode Hot	Active

6-4. Using Remote Voltage/Amperage Control



1 Remote 14 Receptacle RC14
Connect optional remote control to RC14 (see Section 5-10).

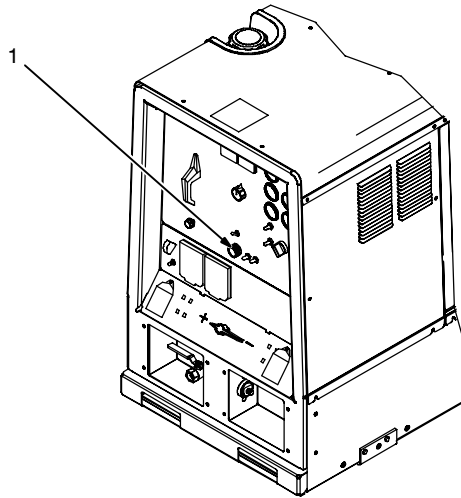

803 231

Example: Combination Remote Amperage Control (Stick)

In Example:
Process = Stick (Using Remote On/Off)
Range = 125 to 400 A DC
Min = 125 A DC
Max = 400 A DC

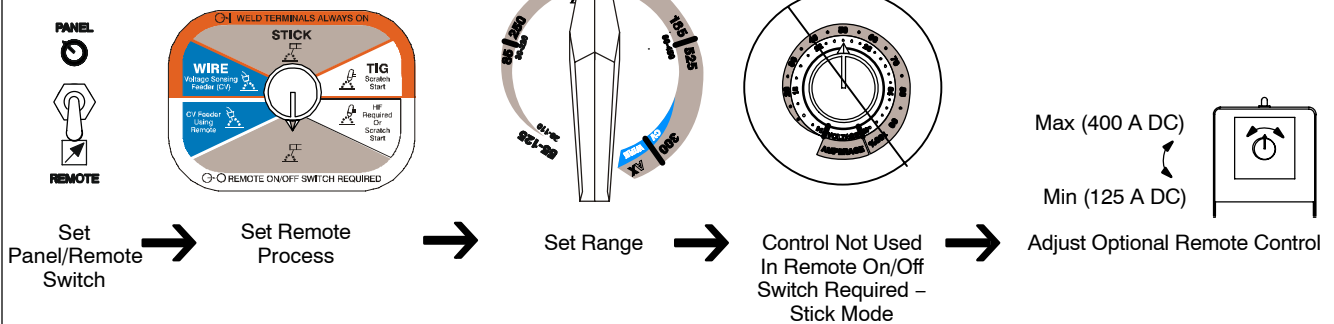

Example: Combination Remote Amperage Control (TIG)

In Example:
Process = TIG (Using Remote On/Off)
Range = 40 to 330 A DC
Percentage Of Range = 50%
Min = 40 A DC
Max = About 185 A DC (50% of 40 to 330)

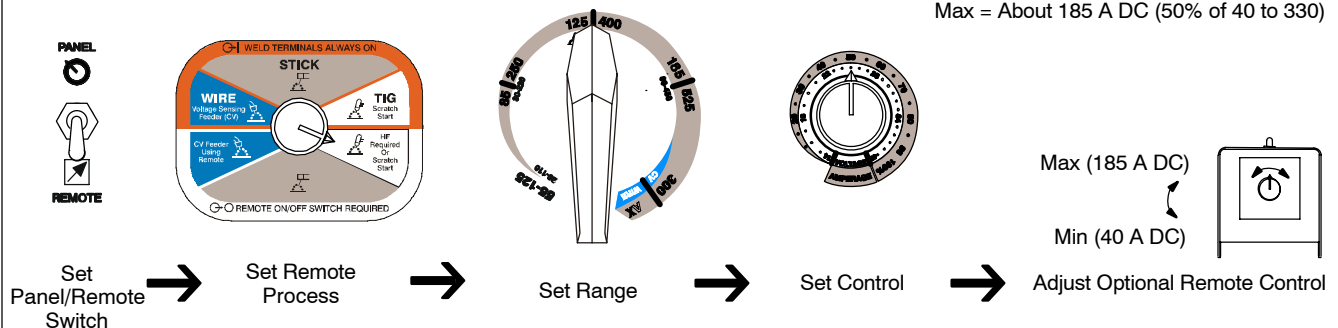

0774 / Ref. 217 356-A / 803 231

SECTION 7 – OPERATING AUXILIARY EQUIPMENT

7-1. 120 Volt And 240 Volt Receptacles

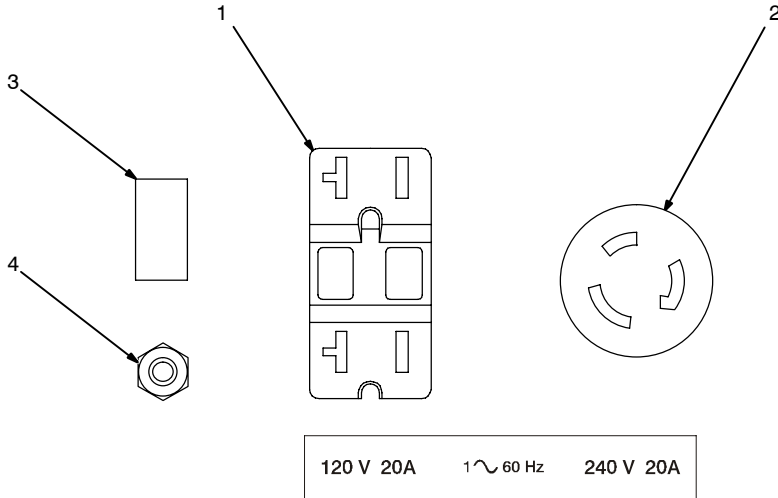

- 1 120 V 20 A AC GFCI Receptacle GFCI1
- 2 240 V 30 A AC Twistlock Receptacle RC1

Receptacles supply 60 Hz single-phase power at weld/power speed.

If a ground fault is detected, GFCI Reset button pops out and receptacle does not work. Check for faulty tools plugged in receptacle. Press button to reset GFCI1.

At least once a month, run engine at weld/power speed and press test button to verify GFCI is working properly.

- 3 Supplementary Protector CB1
- 4 Supplementary Protector CB2

CB1 protects RC1 and the generator winding from overload. If CB1 opens, RC1 and GFCI1 do not work. Place switch in On position to reset.

CB2 protects GFCI1 from overload. If CB2 opens, GFCI1 does not work. Press button to reset.

If a supplementary protector continues to open, contact Factory Authorized Service Agent.

Generator power is not affected by weld output.

Maximum output is 2.4 kVA/kW from GFCI1 and 4 kVA/kW from RC1. Maximum output from all receptacles is 4 kVA/kW.

EXAMPLE: If 13 A is drawn from RC1, only 7 A is available at GFCI1:

$$(240 \text{ V} \times 13 \text{ A}) + (120 \text{ V} \times 7 \text{ A}) = 4.0 \text{ kVA/kW}$$

7-2. Connecting To Optional AC Power Plant



Single-Phase Power Connection

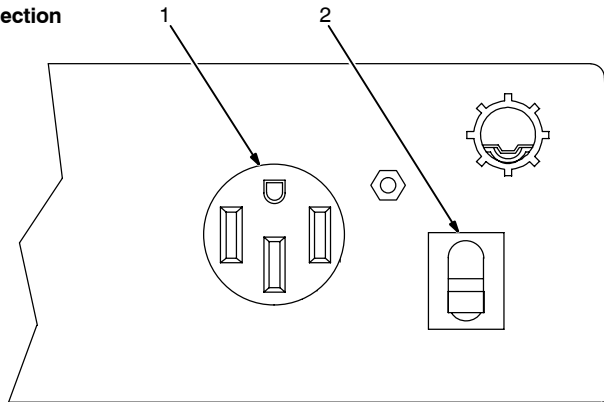

⚠ Do not weld while using optional ac power plant.

⚠ Place Process/Contactor switch in Weld Terminals Always On - Stick position when using optional ac power plant (see Section 6-3).

Single-Phase Generator Power

1 120/240 V 50 A Receptacle RC5

RC5 is connected to the optional ac power plant and supplies 60 Hz single-phase power at weld/power speed. Maximum output from RC5 is 12 kVA/kW. Power available at RC5 is reduced when welding.

2 Supplementary Protector CB7

Supplementary protector CB7 protects single-phase receptacle RC5 and the load wires from overload. If CB7 opens, all generator ac output stops and the receptacle does not work.

Three-Phase Generator Power

⚠ Stop engine.

⚠ Power and weld outputs are live at the same time. Disconnect or insulate unused cables.

⚠ Have qualified person install according to circuit diagram and Generator Power Guidelines (see Section 16).

Three-Phase Power Connection

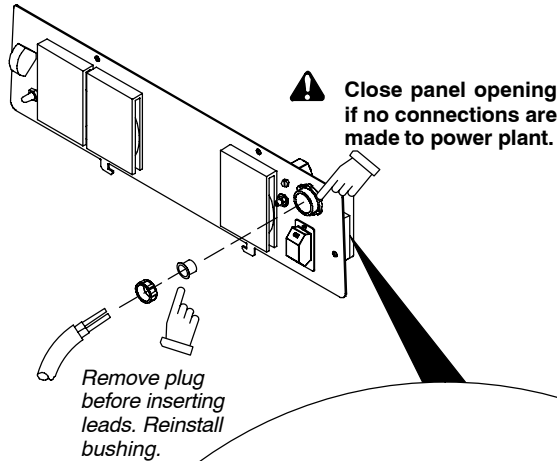

AC ~ Output	Single Phase 1 ~	Three Phase 3 ~
Volts	120/240	240
Amps	50	48
KVA/KW	12	20
Frequency	60 Hz	
Engine Speed	1850 RPM	

Lead 42 connects to GROUND stud on front of unit.
Jumper 42 is connected to 90 at factory.

93 Remove power panel mounting screws. Tilt panel forward.

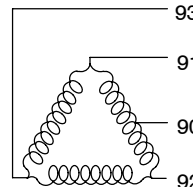

- 3 Lead 93
- 4 Lead 92
- 5 Lead 91
- 6 Lead 42 (Circuit Grounding Lead)
- 7 Lead 90 (Neutral)
- 8 Isolated Neutral Terminal
- 9 Jumper Lead 42
- 10 Grounding Terminal

Jumper 42 is connected to lead 90 at factory. Jumper 42 may be disconnected from neutral to meet applicable electrical codes.

Lead 42 connects to front panel Ground stud.

11 User-Supplied Leads

12 Supplementary Protector CB7 User Terminals

Connect user-supplied leads to terminals on CB7 and to the isolated neutral terminal and grounding terminal as necessary.

⚠ Supplementary protector CB7 protects single-phase receptacle RC5 and the load wires from overload. If CB7 opens, all ac power plant output stops and the receptacle does not work.

Reinstall power panel.

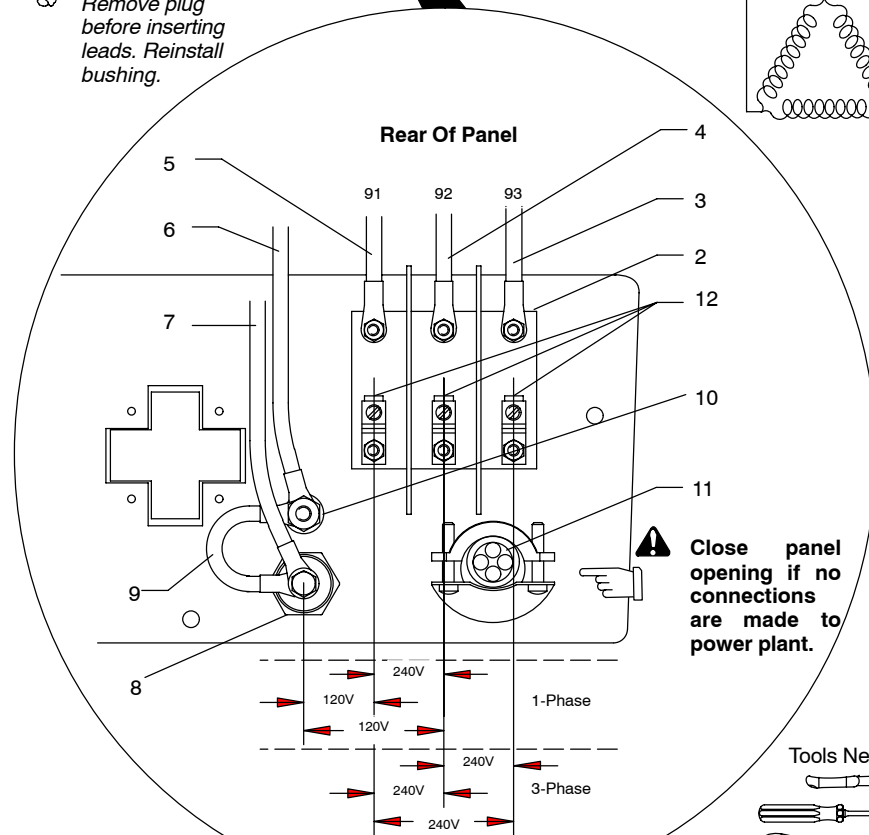

Tools Needed:

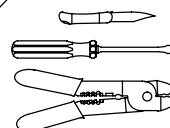

7-3. Optional Generator Power Receptacles



European Receptacle

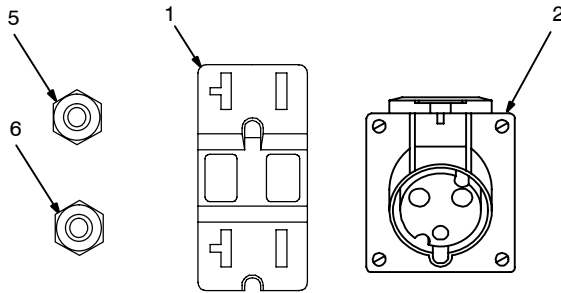

120 V 20A 1~ 60 Hz 240 V 15 A

- 1 120 V 20 A AC GFCI Receptacle GFCI1
- 2 240 V 16 A AC European Receptacle RC1
- 3 240 V 15 A AC Australian Receptacle RC1
- 4 240 V 15 A AC South African Receptacle RC1

Receptacles supply 60 Hz single-phase power at weld/power speed.

If a ground fault is detected, the GFCI Reset button pops out and the receptacle does not work. Check for faulty tools plugged in receptacle. Press button to reset GFCI1.

At least once a month, run engine at weld/power speed and press test button to verify GFCI is working properly.

- 5 Supplementary Protector CB2
 - 6 Supplementary Protector CB3
- CB2 protects GFCI1 from overload. If CB2 opens, GFCI1 does not work. Place button to reset breaker.
- CB3 protects RC1 from overload. If CB3 opens, RC1 does not work. Press button to reset breaker.

If a supplementary protector continues to open, contact Factory Authorized Service Agent.

Generator power is not affected by weld output.

Maximum output is 2.4 kVA/kW from GFCI1 and 4 kVA/kW from RC1. Maximum output from all receptacles is 4 kVA/kW.

EXAMPLE: If 13 A is drawn from RC1, only 7 A is available at GFCI1:
 $(240 \text{ V} \times 13 \text{ A}) + (120 \text{ V} \times 7 \text{ A}) = 4.0 \text{ kVA/kW}$

Australian Receptacle

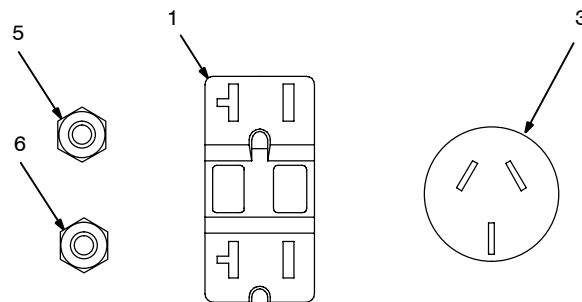

120 V 20A 1~ 60 Hz 240 V 15 A

South African Receptacle

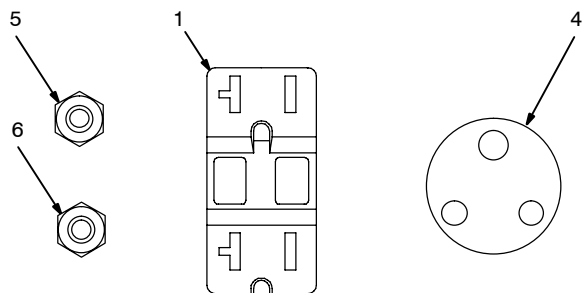

120 V 20A 1~ 60 Hz 240 V 15 A

SECTION 8 – OPERATING OPTIONAL BATTERY CHARGER

8-1. Battery Charge Controls

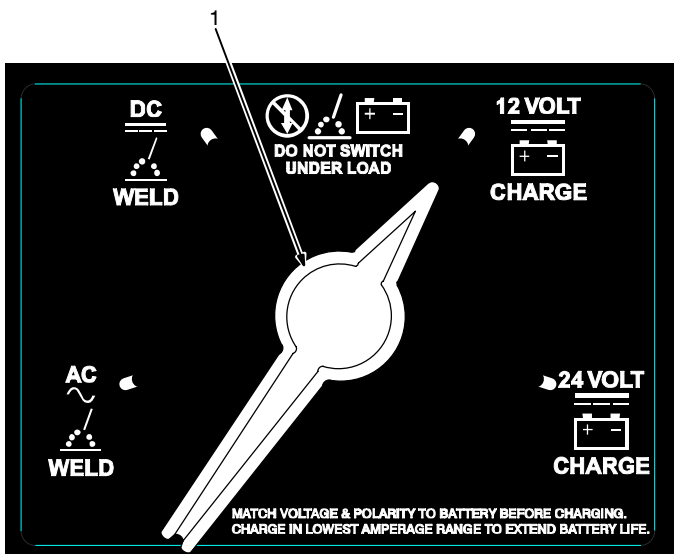
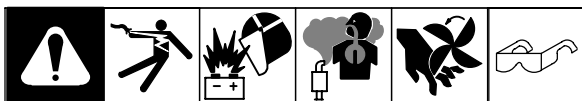

1 Output Selector Switch

NOTICE – Do not switch under load. Stop engine or set Process/Contactor switch to any Remote position before switching.

Use switch to select weld or battery charge output. Output automatically decreases (but does not stop) when terminal voltage is 15 to 25 percent above required battery voltage.

☞ Before connecting charging cables, place Output Selector switch in position matching voltage of battery being charged.

When done charging, stop engine or set Process/Contactor switch to any Remote On/Off Switch Required position. Move Output Selector switch to AC Weld or DC Weld position.

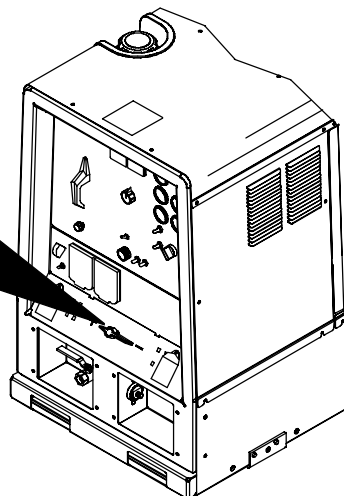

803 231-A / 210 149-B

8-2. Determining Battery Charging Current

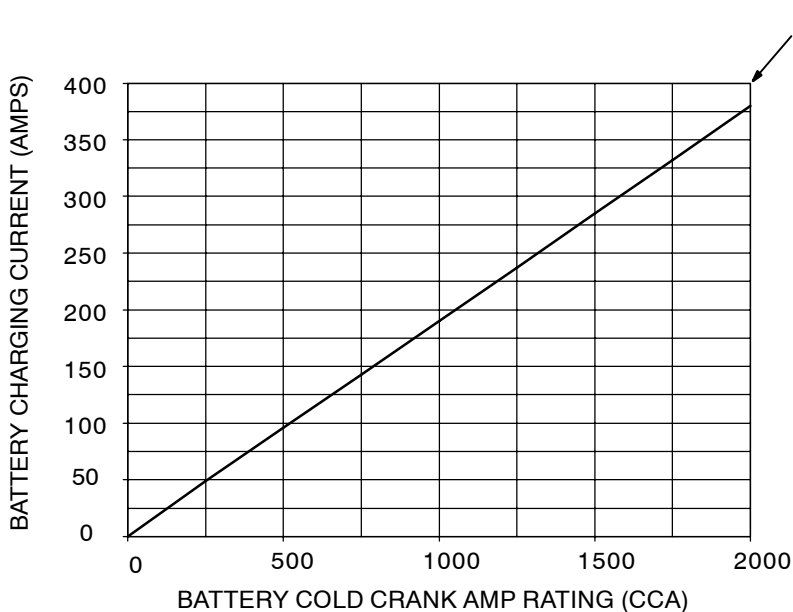

1 Battery Charging Current Chart

Find battery cold crank amp (CCA) rating on battery. Use CCA rating on chart to find charge current setting for battery.

EXAMPLE: If battery CCA rating is 500, charging current from chart is 100 amperes.

Do not exceed charging current found on chart. For longer battery life, use lowest charge rate possible.

142 975-B

8-3. Battery Charge Cable Connections

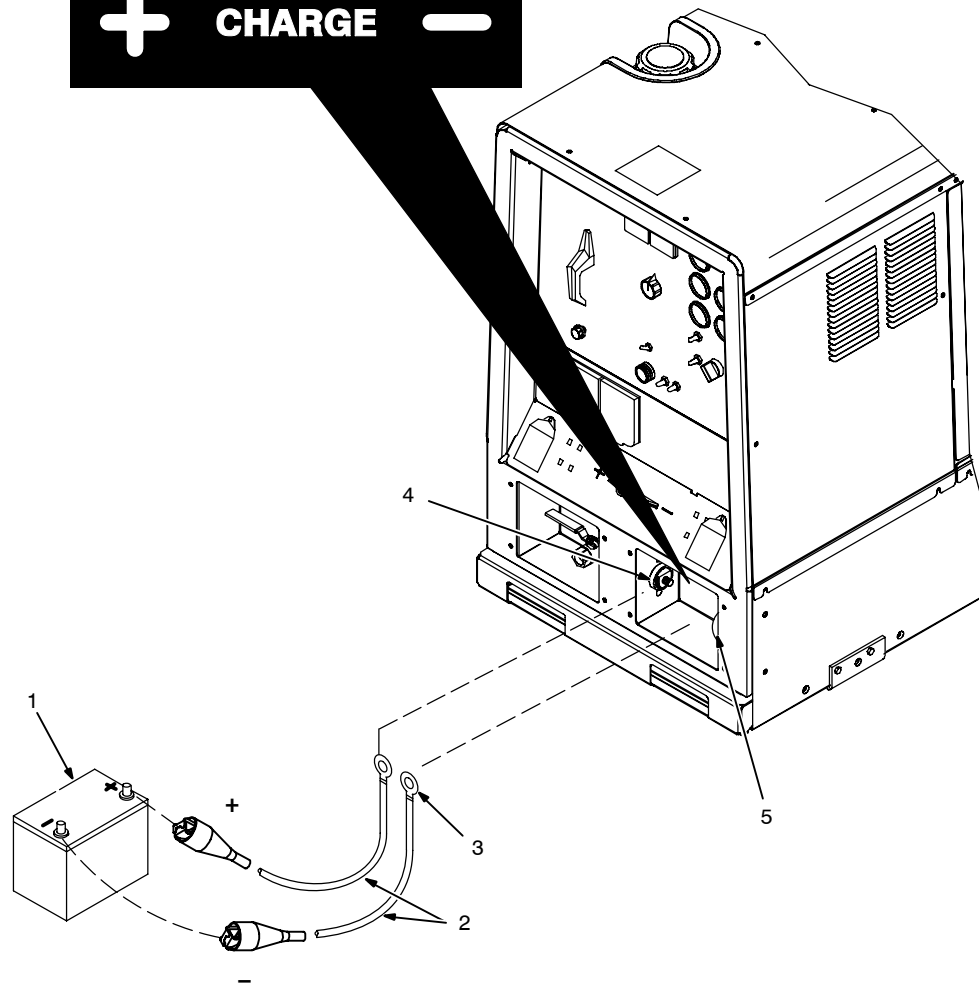
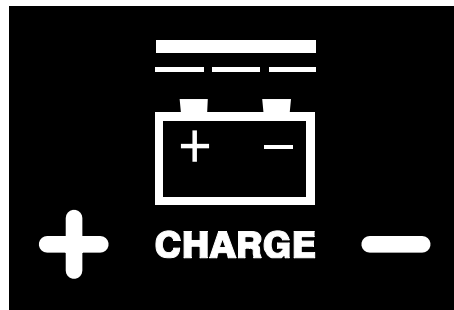
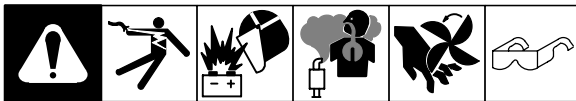

- ⚠ Stop engine.**
- ⚠ Do not charge or jump start a battery which has loose terminals or one showing damage such as a cracked case or cover.**
- ⚠ Have only qualified persons do battery charging work.**
- ⚠ Keep cables away from moving parts.**
- ⚠ Do not use damaged cables.**
- ⚠ Be sure charger output voltage matches battery voltage.**

- ⚠ Read BCI Battery Service Manual before charging or jump starting.**

Before connecting to battery, place Output Selector switch in position matching voltage of battery being charged.

- 1 Battery
- 2 Battery Charging Cables

For battery charging, use less than 20 feet (6.1 m) of AWG #1 or larger cable. For jump starting, use less than 20 feet (6.1 m) of AWG 2/0 or larger cable.

- 3 Terminal Lug

803 231-A / 210 156 / Ref. S-0714 / Ref. S-0756

Use lugs of proper amperage capacity and hole size for connecting to charge output terminals.

Install suitable connectors on remaining ends of battery cables.

- 4 Battery Charge Positive (+) Output Terminal
- 5 Battery Charge Negative (-) Output Terminal

Connect charging cables to battery charge output terminals before connecting to battery terminals.

Connect Battery Charge Positive (+) cable to battery positive (+) terminal, and battery Charge Negative (-) cable to battery negative (-) terminal.

8-4. Battery Charging Procedure

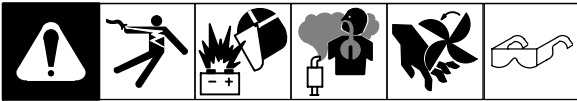

In Example:
 Battery Voltage = 12 Volts
 Battery CCA Rating = 500
 Charge Current = 100 A (See Section 8-2)
 Ampere Range Setting = 55 to 125 A
 V/A Control Setting = Any Position

This battery charging procedure uses the front panel controls to turn charging output on and off.



Stop Engine.

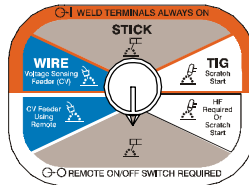

Set Process/Contactor Switch To Any Remote On/Off Switch Required Position.

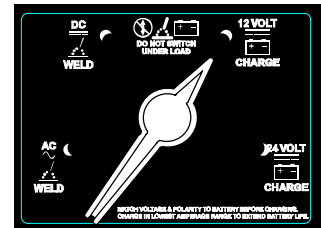

Set Output Selector Switch To Voltage Of Battery Being Charged (12 Or 24 Volt).

NOTICE – Do not switch under load.

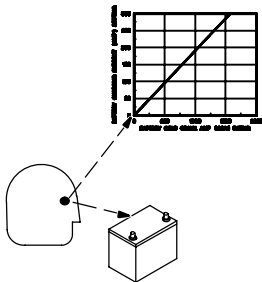

Determine Charge Current From Battery CCA Rating And Chart (See Section 8-2).

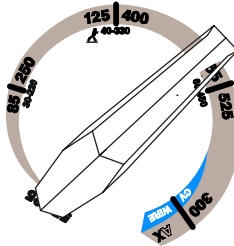

Set Ampere Range Switch To Lowest Range That Exceeds Charge Current.

NOTICE – Do not switch under load.

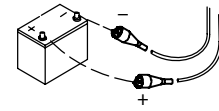

Connect Cables (Observe Correct Polarity).



Start Engine.

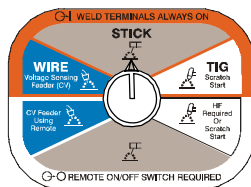

Set Process/Contactor Switch To Any Weld Terminals Always On Position To Begin Charging.

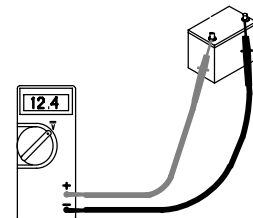

Charge 10 minutes. Check Battery Voltage. Continue Charging If Necessary.

To control battery charging output using a remote device connected to the Remote 14 receptacle, keep Process/Contactor switch in Remote On/Off Switch Required position and use remote device to turn charging output on and off.

8-5. Jump Starting Procedure

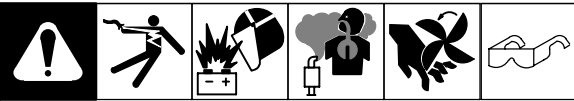

☞ Charge battery for 10 minutes before jump starting battery.

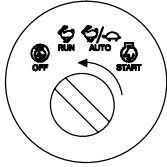

Stop Engine.

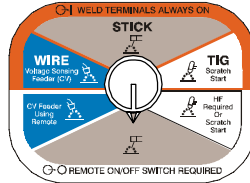

Set Process/Contactor Switch To Any Remote On/Off Switch Required Position.

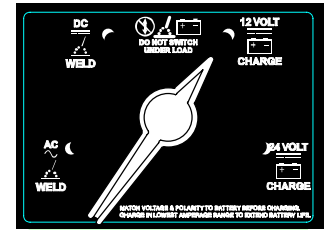

Set Output Selector Switch To Voltage Of Battery Being Charged (12 Or 24 Volt).

NOTICE – Do not switch under load.

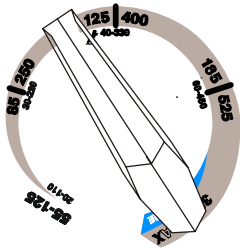

Set Ampere Range Switch To 300-Max Position.

NOTICE – Do not switch under load.

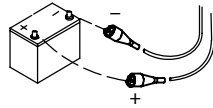

Connect Cables (Observe Correct Polarity).

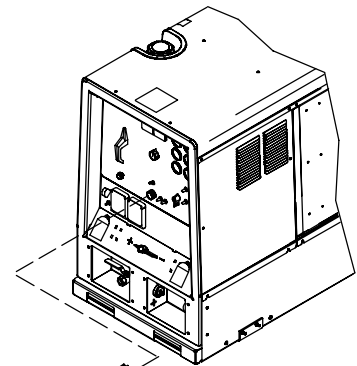

Connect Remote Control Device (Momentary-On Switch).

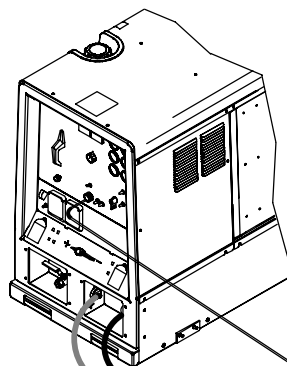

Press (close) switch only while cranking engine of equipment being started.

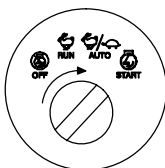

Start Engine.

Press (Close) Remote Momentary-On Switch While Cranking Engine Of Equipment Being Jump Started. Release Switch When Equipment Starts. Stop Welding Generator And Disconnect Cables.

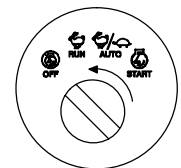

Stop Engine. Disconnect Cables.

SECTION 9 – ENGINE/GENERATOR MAINTENANCE

9-1. Engine Maintenance Label

**DEUTZ BF4M 2011 (63.4HP)
DIESEL ENGINE**

100 h std.

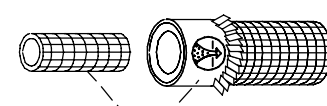

MILLER 192 939
Donaldson P822769
WIX 46490

MILLER 192 938
Donaldson P822768
WIX 46489

250 h std.



MILLER 207 808
Gates XL7445

12 V
BCI 24
650 A @ -18C (0F)



8 h std.

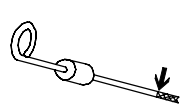

DIESEL
93.7 L (24.75 gal)
DIN 51 601
BS 2869: A1, A2
ASTM D 975-81: 1-D, 2-D
VV-F 800C: DF-A, DF-1, DF-2
S < = .5%

250 h std.

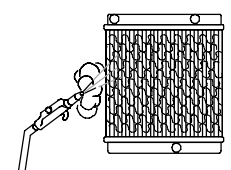

MILLER 067 265
Deutz 117-4416
Fram PH46

500 h std.

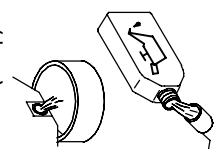

API: CD/CE/CF-4
10.4 L (11 qt)

500 h std.

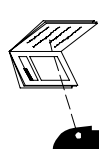
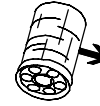

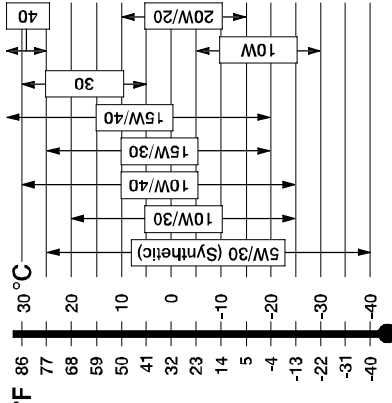

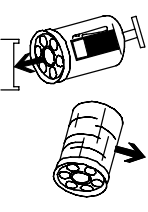

1000 h std.

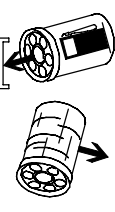

1. MILLER 192 744
Donaldson P550587
Fram P1145A



2. MILLER 066 217
Deutz 117-4696
Donaldson P550345

3000 h std.

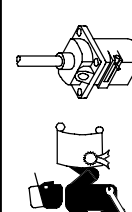

20° C (72° F)
in.- 0.3 mm (0.012 in)
ex.- 0.5 mm (0.020 in)

6000 h / 5 yr std.

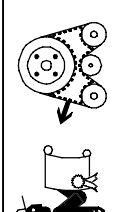

6000 h / 5 yr std.

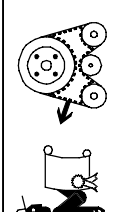

206 464-C

OM-4409 Page 43

Download from Www.Somanuals.com. All Manuals Search And Download.

9-2. Routine Engine/Generator Maintenance

☞ See Section 10 for air compressor maintenance information.

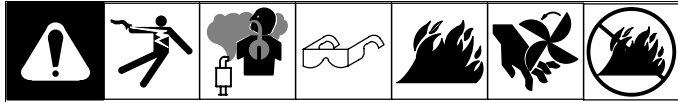

Recycle engine fluids.

Stop engine before maintaining.
☞ See Engine Manual and Maintenance Label for important start-up, service, and storage information. Service engine more often if used in severe conditions.

	✓ = Check * To be done by Factory Authorized Service Agent	◇ = Change	● = Clean	☆ = Replace	Reference
Every 8 Hours	 ✓ Fuel/Water Separator	 ✓ Fuel Level	 ✓ Oil Level	 ● Oil, Fuel Spills	Section 5-7, 9-6
Every 50 Hours	 ● Weld Terminals				
Every 100 Hours	 ● Battery Terminals	 ✓ Air Cleaner Hoses	 ✓ Air Cleaner Element		Section 9-4
Every 250 Hours	 ☆ Unreadable Labels	 ✓ Fan Belt Tension	 ● Cooling System	 ✓ ● Spark Arrestor	Engine Manual, Section 9-5
Every 500 Hours	 ✓ ☆ Weld Cables	 ◇ Oil	 ◇ Oil Filter		
Every 1000 Hours	 ◇ Fuel Filter	 ● Inside Unit	 ✓ Valve Clearance*	 ● Drain Sludge	Section 9-6, 9-3 and Engine Manual
	 ✓ ● Slip Rings* ✓ ☆ Brushes*				
Every 3000 Hours	 ● Injectors*				
Every 6000 Hours or 5 Years	 ✓ ☆ Engine Timing Belt				

9-3. Checking Generator Brushes

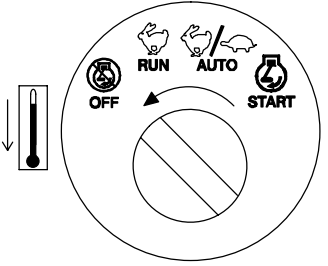
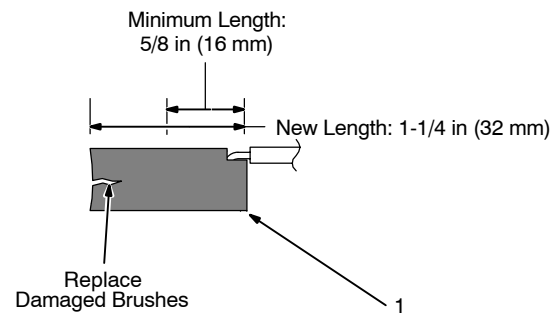
⚠ Stop engine and let cool.

1 Generator Brush













Remove brushes from brush holder.

Replace brushes if damaged or if brush material is at or near minimum length.

Ref. 206 467

Notes

MATERIAL THICKNESS REFERENCE CHART

	24 Gauge (.025 in)
	22 Gauge (.031 in)
	20 Gauge (.037 in)
	18 Gauge (.050 in)
	16 Gauge (.063 in)
	14 Gauge (.078 in)
	1/8 in (.125 in)
	3/16 in (.188 in)
	1/4 in (.25 in)
	5/16 in (.313 in)
	3/8 in (.375 in)
	1/2 in (.5 in)

9-4. Servicing Engine Air Cleaner

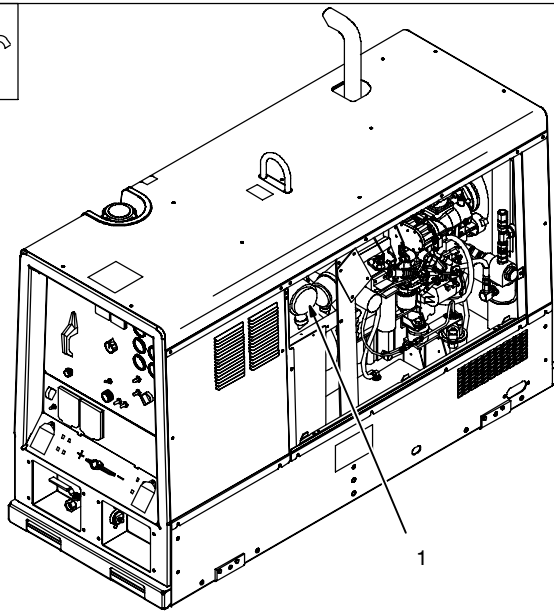
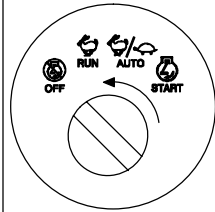

Stop engine.

NOTICE – Do not run engine without air cleaner or with dirty element. Engine damage caused by using a damaged element is not covered by the warranty.

1 Engine Air Cleaner

The air cleaner primary element can be cleaned but the dirt holding capacity of the filter is reduced with each cleaning. The chance of dirt reaching the clean side of the filter while cleaning and the possibility of filter damage makes cleaning a risk. Consider the risk of unwarrantable equipment damage when determining whether to clean or replace the primary element.

If you decide to clean the primary element, we strongly recommend installing an optional safety element to provide additional engine protection. **Never clean a safety element.** Replace the safety element after servicing the primary element three times.

Clean or replace primary element if dirty (see note above before cleaning). **Replace** primary element if damaged. Replace primary element yearly or after six cleanings.

- 2 Housing
- 3 Safety Element (Optional)
- 4 Primary Element
- 5 Dust Cap
- 6 Dust Ejector

To clean air filter:

Wipe off cap and housing. Remove cap and dump out dust. Remove element(s). Wipe dust from inside cap and housing with damp cloth. Reinstall safety element (if present). Reinstall cap.

NOTICE – Do not clean housing with air hose.

Clean primary element with compressed air only.

Air pressure must not exceed 100 psi (690 kPa). Use 1/8 in (3 mm) nozzle and keep nozzle at least 2 in (51 mm) from inside of element. Replace primary element if it has holes or damaged gaskets.

Reinstall primary element and cap (dust ejector down).

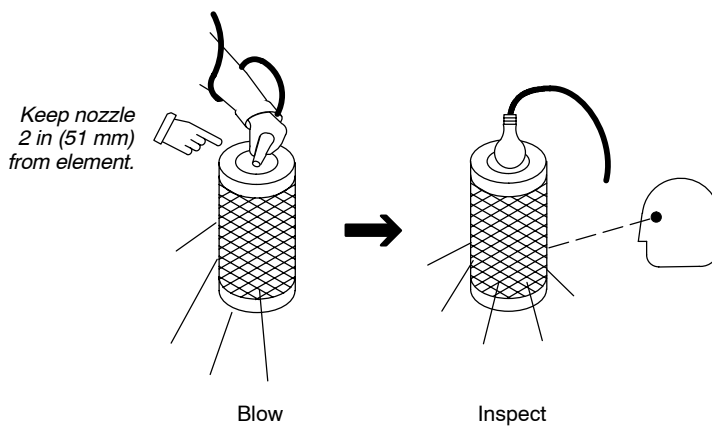
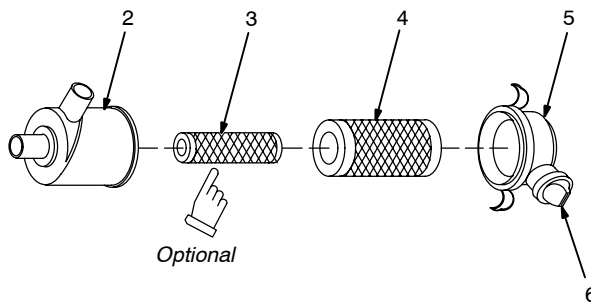

9-5. Inspecting/Cleaning Optional Spark Arrestor Muffler

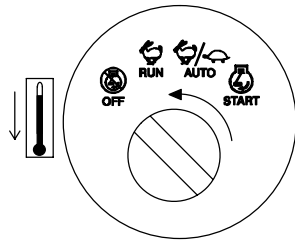
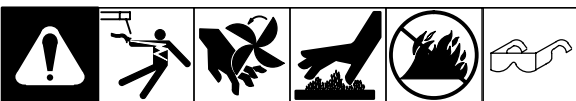

⚠ Stop engine and let cool.

- 1 Spark Arrestor Muffler
- 2 Cleanout Plug

Remove plug and remove any dirt covering cleanout hole.

Start engine and run at idle speed to blow out cleanout hole. If nothing blows out of hole, briefly cover end of exhaust pipe with fireproof material.

⚠ Stop engine and let cool.

Reinstall cleanout plug.

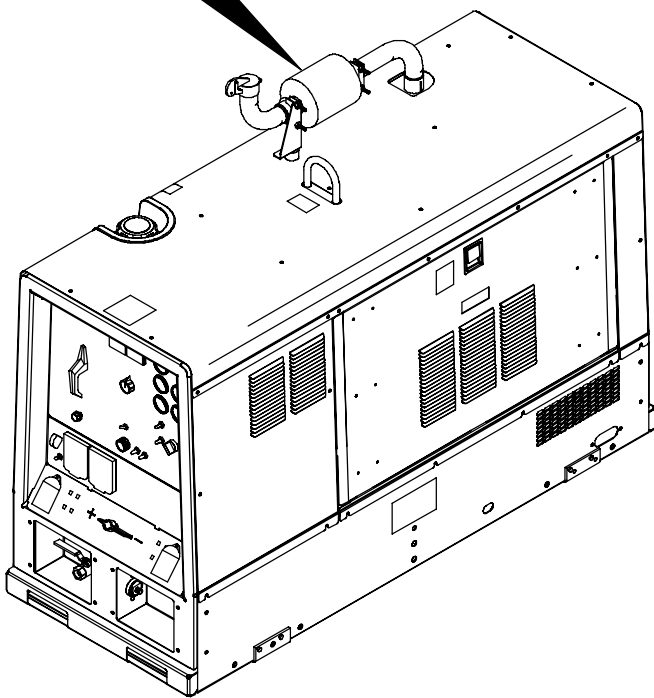
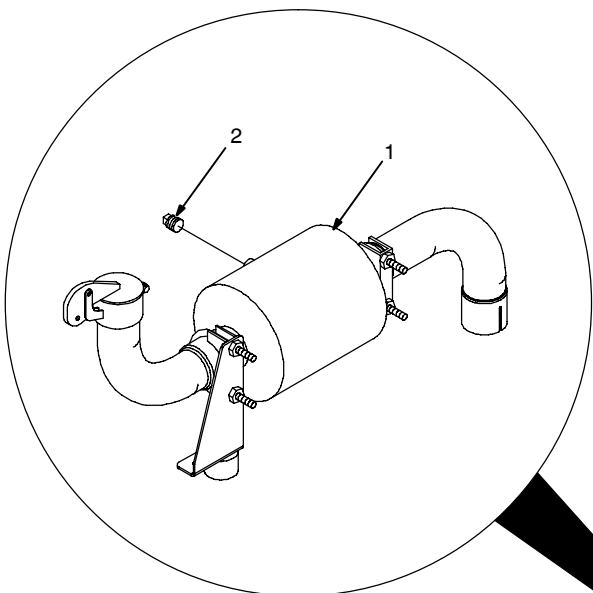

Tools Needed:

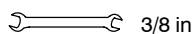

803 228 / 803 230

9-6. Adjusting Engine Speed

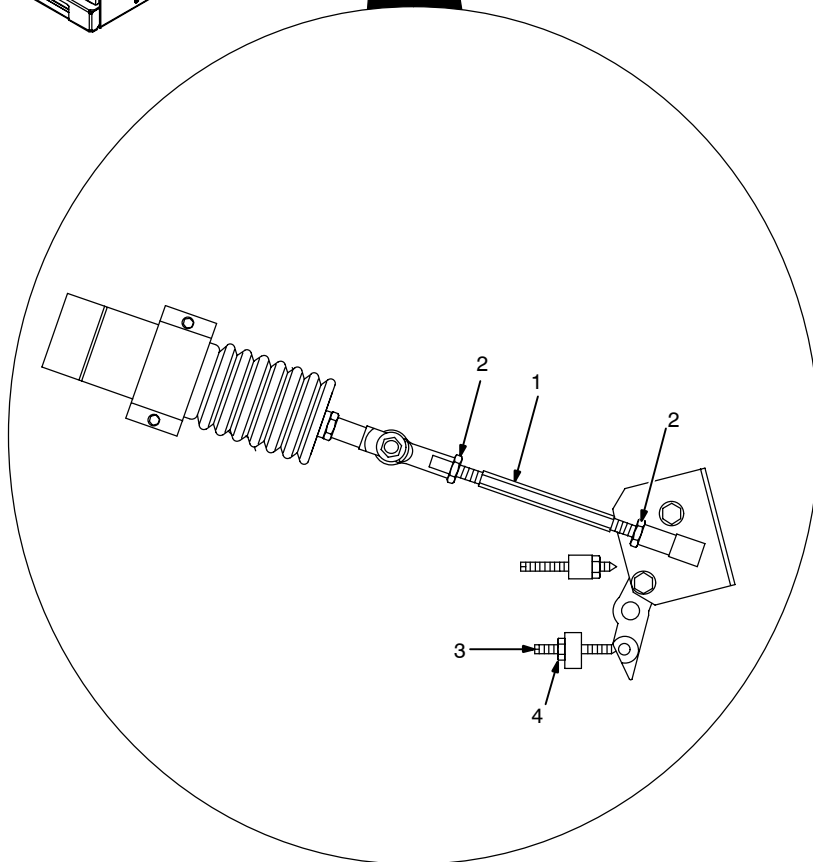
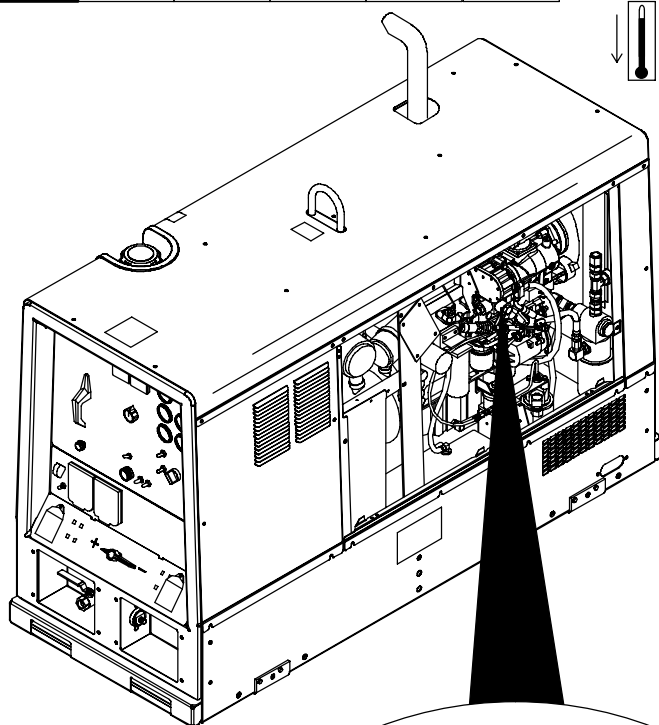
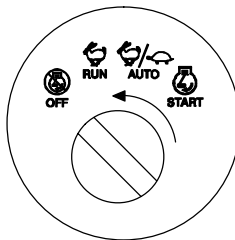

⚠ Stop engine and let cool.

Engine speed is factory set and should not require adjustment. After tuning engine, check engine no load speed with a tachometer or frequency meter (see table for no load speeds). If necessary, adjust speed as follows:

Start engine and run until warm.

Turn Process/Contactor switch to Weld Terminals Always On – Stick position.

- 1 Throttle Rod
- 2 Locknut

Loosen locknuts. Place engine control switch in Run/Idle position.

Wait 15 seconds for throttle solenoid to energize and lower engine speed to idle rpm.

Turn throttle rod to adjust idle speed. Tighten locknuts.

- 3 Engine Speed Adjustment Screw
- 4 Locknut

Place engine control switch in Run position.

Loosen locknut. Turn screw to adjust weld/power speed. Tighten locknut.

⚠ Do not set engine speed higher than specified.

⚠ Stop engine.

Close door.

	1850 rpm Max. (61.6 Hz)
	1235 rpm (41.1 Hz)

Tools Needed:

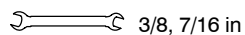

803 228 / 802 313-A

9-7. Servicing Engine Fuel And Lubrication Systems

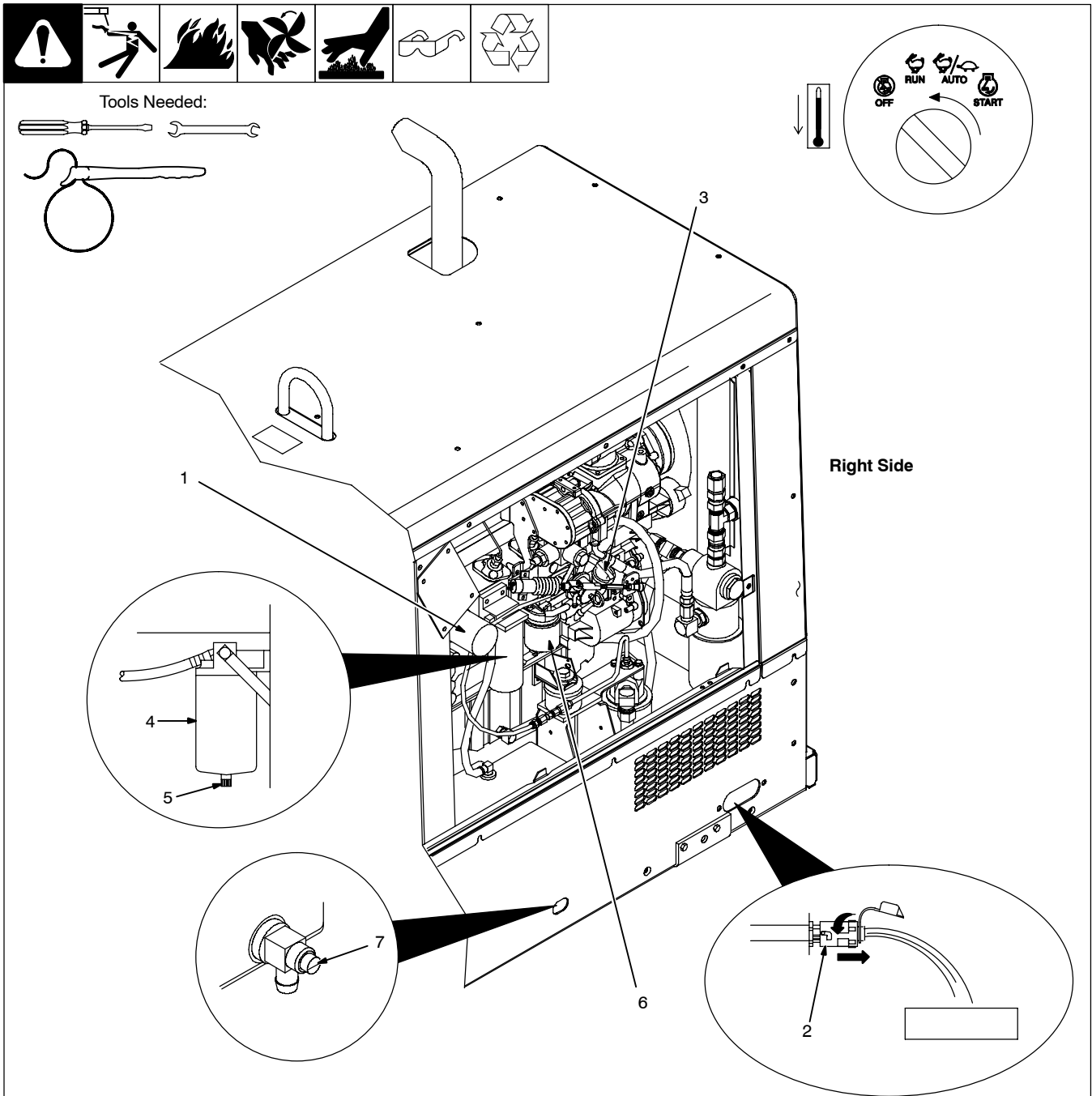

⚠ Stop engine and let cool.

⚠ After servicing, start engine and check for fuel leaks. Stop engine, tighten connections as necessary, and wipe up spilled fuel.

- 1 Oil Filter
- 2 Oil Drain Hose And Valve
- 3 Oil Fill Cap
- 4 Primary Fuel Filter (Fuel/Water Separator)
- 5 Petcock
- 6 Secondary Fuel Filter
- 7 Fuel Tank Sludge Drain Valve

To change oil and filter:

 The engine oil drain and compressor oil drain hoses are located together in the

base. Be sure to select the correct hose when draining engine oil.

Route engine oil drain hose through hole in base. See engine manual and engine maintenance label for oil specifications.

To drain water from fuel system:

Open primary fuel filter petcock and drain water into metal container. Close petcock when water-free fuel flows.

To replace primary fuel filter:

Turn filter counterclockwise. Remove filter. Apply thin coat of fuel to gasket on new filter. Fill filter with fuel. Install filter and turn clockwise until tight. Bleed air from fuel system according to engine manual.

Inspect fuel lines, and replace if cracked or worn.

To replace secondary fuel filter:

See engine manual.

Close doors.

To drain sludge from fuel tank:

⚠ Beware of fire. Do not smoke and keep sparks and flames away from drained fuel. Dispose of drained fuel in an environmentally-safe manner. Do not leave unit unattended while draining fuel tank.

⚠ Properly lift unit and secure in a level position. Use adequate blocks or stands to support unit while draining fuel tank.

Attach 1/2 ID hose to drain valve. Put metal container under drain, and use screwdriver to open sludge drain valve. Close valve when sludge has drained. Remove hose.

803 228

9-8. Engine/Generator Overload Protection

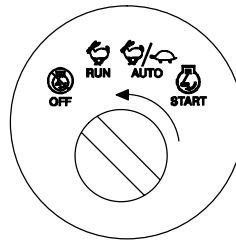

Stop engine.

☞ When a supplementary protector, circuit breaker or fuse opens, it usually indicates a more serious problem exists. Contact Factory Authorized Service Agent.

☞ See Section 10-4 for air compressor overload protection.

- 1 Fuse F1
- 2 Fuse F2

F1 and F2 protect the stator exciter winding from overload. If F1 opens, weld and generator power is low or stops entirely. If F2 opens, weld output is low or stops entirely. 4 kVA/kW generator power is still available.

- 3 Circuit Breaker CB4 (Not Shown)
- 4 Supplementary Protector CB5
- 5 Supplementary Protector CB6
- 6 Circuit Breaker CB10 (Not Shown)
- 7 Supplementary Protector CB11
- 8 Supplementary Protector CB12
- 9 Supplementary Protector CB13
- 10 Circuit Breaker CB14 (Not Shown)

CB4 protects the welding arc drive (dig) circuit. If CB4 opens, electrode may stick to the workpiece more frequently during low voltage (short arc length) conditions. CB4 automatically resets when the fault is corrected.

CB5 protects the 24 volt ac output to remote receptacle RC14, and 24 volt output to field current regulator board PC1. If CB5 opens, weld output and 24 volt output to RC14 stops. On units with optional power plant, power at receptacle RC5 also stops if CB5 opens.

CB6 protects the 115 volt ac output to remote receptacle RC14. If CB6 opens, 115 volt output to RC14 stops.

CB10 protects the engine battery circuit. If CB10 opens, the engine will not crank. CB10 automatically resets when the fault is corrected.

CB11 protects the engine wiring harness. If CB11 opens, weld output stops (generator power is still available).

CB12 protects the field flashing circuit. If CB12 opens, the generator may not excite at start-up and weld and generator power output may not be available.

CB13 protects the engine shutdown circuit. If CB13 opens, the engine cranks but does not start.

Press button to reset.

CB14 protects the throttle solenoid. If CB14 opens, the engine will not run at idle speed. CB14 automatically resets when the fault is corrected.

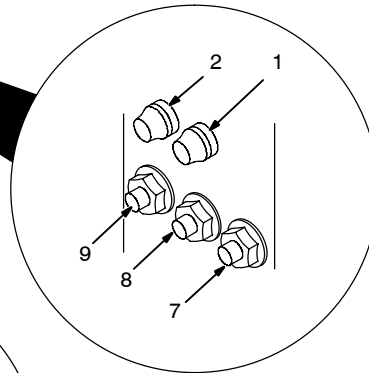
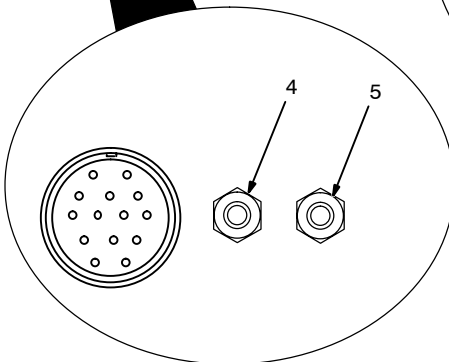
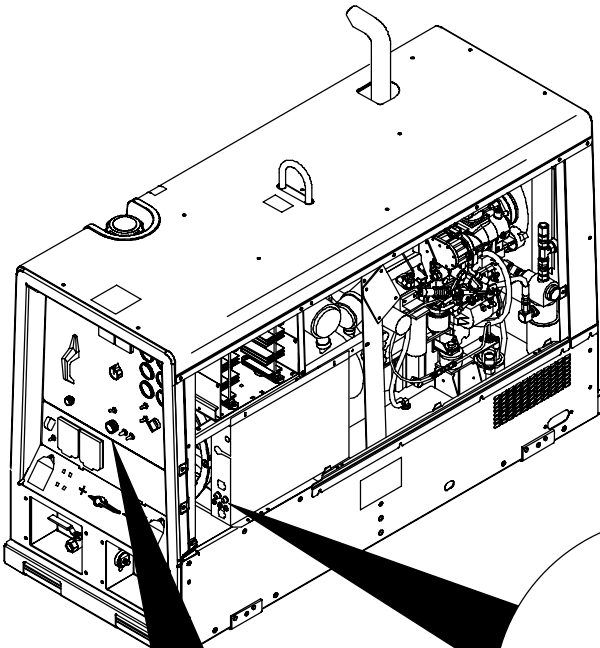

SECTION 10 – AIR COMPRESSOR MAINTENANCE

☞ Use only genuine Ingersoll Rand compressor oil and filters to maintain 3-year warranty on air compressor. The air compressor warranty will be reduced to 2 years if non-Ingersoll Rand oil and filters are used

The air compressor normally requires service at the intervals listed in the maintenance schedule if used in a clean, dry environment. The compressor will require service more often if used in dirty, humid conditions.

10-1. Air Compressor Maintenance Label

INGERSOLL RAND CE55 G
AIR COMPRESSOR

8 h std.

250 h std.

MILLER: 218 609
Gates: K060578

MILLER: 197 679
Donaldson: P822858
WIX: 42985

MILLER: 197 676
Donaldson: P821575
WIX: 46438

500 h / 6 m std.

3.8 L (4 qt.)

Ingersoll Rand approved oil & filters must be used to maintain 3 yr warranty.

125°F to -10°F 52°C to -23°C	125°F to -40°F 52°C to -40°C
Ingersoll Rand: PRO-TEC 3689698	Mobil 1: Synthetic ATF
MILSPEC: MIL-PRF 2104G SAE 10W	MILSPEC: MIL-L-46167

MILLER: 206 745
Ingersoll Rand: 39329602

1000 h / 1 yr std.

Air/Oil Separator
MILLER: 206 747
Ingersoll Rand: 89259337

207 448-C

OM-4409 Page 51

Download from Wwww.Somanuals.com. All Manuals Search And Download.

10-2. Routine Air Compressor Maintenance

☞ See Section 9 for engine/generator maintenance information.

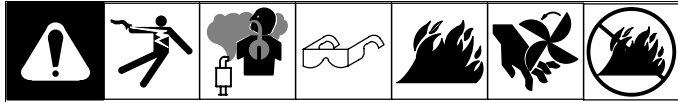

Recycle air compressor fluids.

Stop engine before maintaining.

☞ See Compressor Maintenance Label for important start-up, service, and storage information. Service air compressor more often if used in severe conditions.

	✓ = Check * To be done by Factory Authorized Service Agent	◇ = Change	● = Clean	☆ = Replace	Reference
Every 8 Hours	● Spills	✓ Oil Level			Section 5-7
Every 100 Hours	✓ Air Cleaner Hoses				
Every 250 Hours	☆ Unreadable Labels	✓ Belt Tension	● Cooling System	✓ Air Filter Element	Section 10-3
	☆ Worn or Damaged Air/Oil Hoses				
Every 500 Hours	◇ Oil	◇ Oil Filter			Section 10-5
Every 1000 Hours	◇ Air/Oil Separator				Section 10-5

10-3. Servicing Compressor Air Cleaner

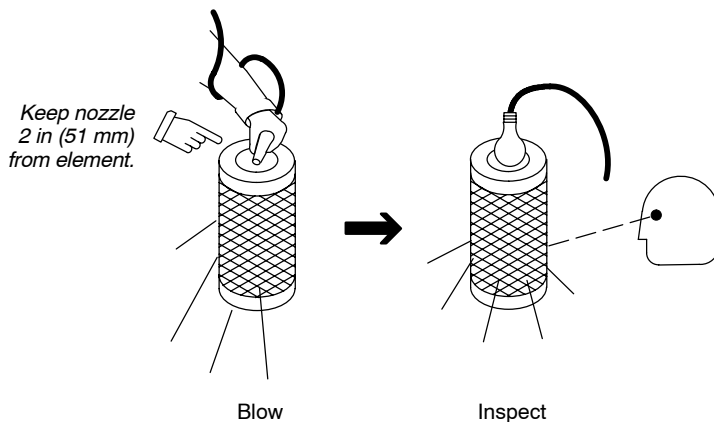
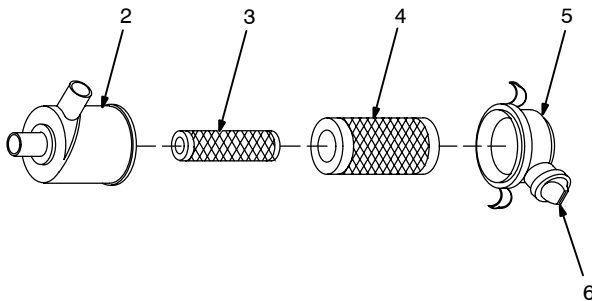
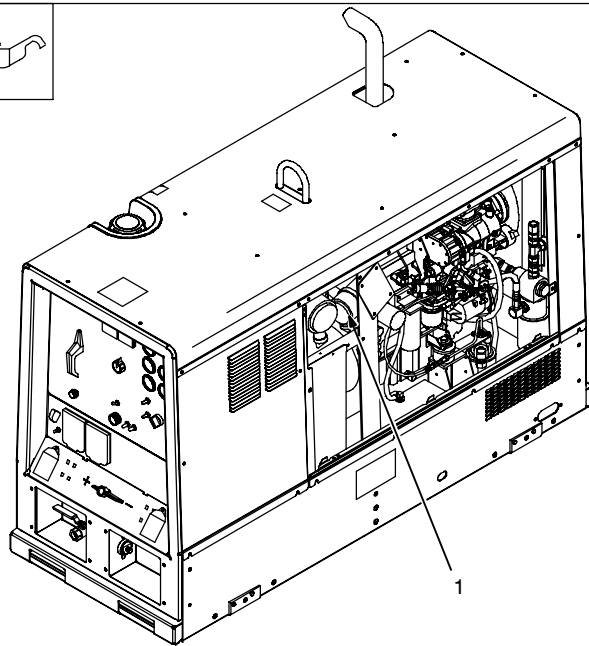
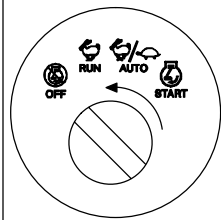

⚠ Stop engine.

NOTICE – Do not run air compressor without air cleaner or with dirty element. Compressor damage caused by using a damaged element is not covered by the warranty.

1 Compressor Air Cleaner

☞ Remove *engine* air cleaner cover and element to access compressor air cleaner (see Section 9-4)

☞ The air cleaner primary element can be cleaned but the dirt holding capacity of the filter is reduced with each cleaning. The chance of dirt reaching the clean side of the filter while cleaning and the possibility of filter damage makes cleaning a risk. Consider the risk of unwarrantable equipment damage when determining whether to clean or replace the primary element.

If you decide to clean the primary element, we strongly recommend installing an optional safety element to provide additional air compressor protection. **Never clean a safety element.** Replace the safety element after servicing the primary element three times.

Clean or replace primary element if dirty (see note above before cleaning). **Replace** primary element if damaged. Replace primary element yearly or after six cleanings.

2 Housing

3 Safety Element

4 Primary Element

5 Cover

6 Dust Ejector

To clean air filter:

Wipe off cover and housing. Remove cover and dump out dust. Remove element(s). Wipe dust from inside cover and housing with damp cloth. Reinstall safety element (if present). Reinstall cover.

NOTICE – Do not clean housing with air hose.

Clean primary element with compressed air only.

Air pressure must not exceed 100 psi (690 kPa). Use 1/8 in (3 mm) nozzle and keep nozzle at least 2 in (51 mm) from inside of element. Replace primary element if it has holes or damaged gaskets.

Reinstall primary element and cover (dust ejector down).

10-4. Compressor Overload Protection

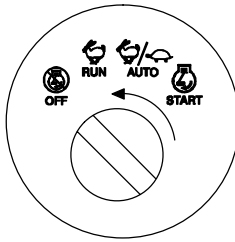

Stop engine.

 When a circuit breaker or fuse opens, it usually indicates a more serious problem exists. Contact Factory Authorized Service Agent.

 See Section 9-8 for engine/generator overload protection.

1 Circuit Breaker CB15

Circuit breaker CB15 protects the air compressor clutch. If CB15 opens, the compressor does not run and air output stops.

Press button to reset breaker.

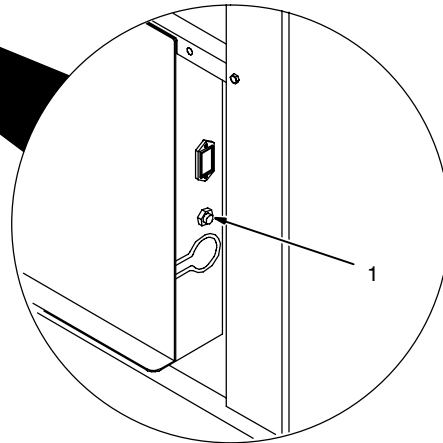
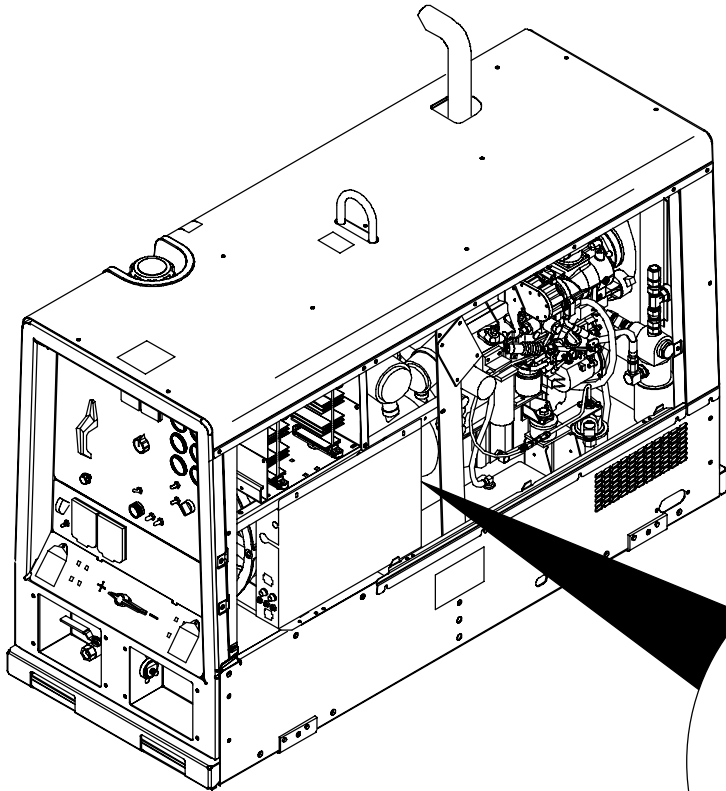

10-5. Servicing Air Compressor



Tools Needed:

7/8, 15/16 in

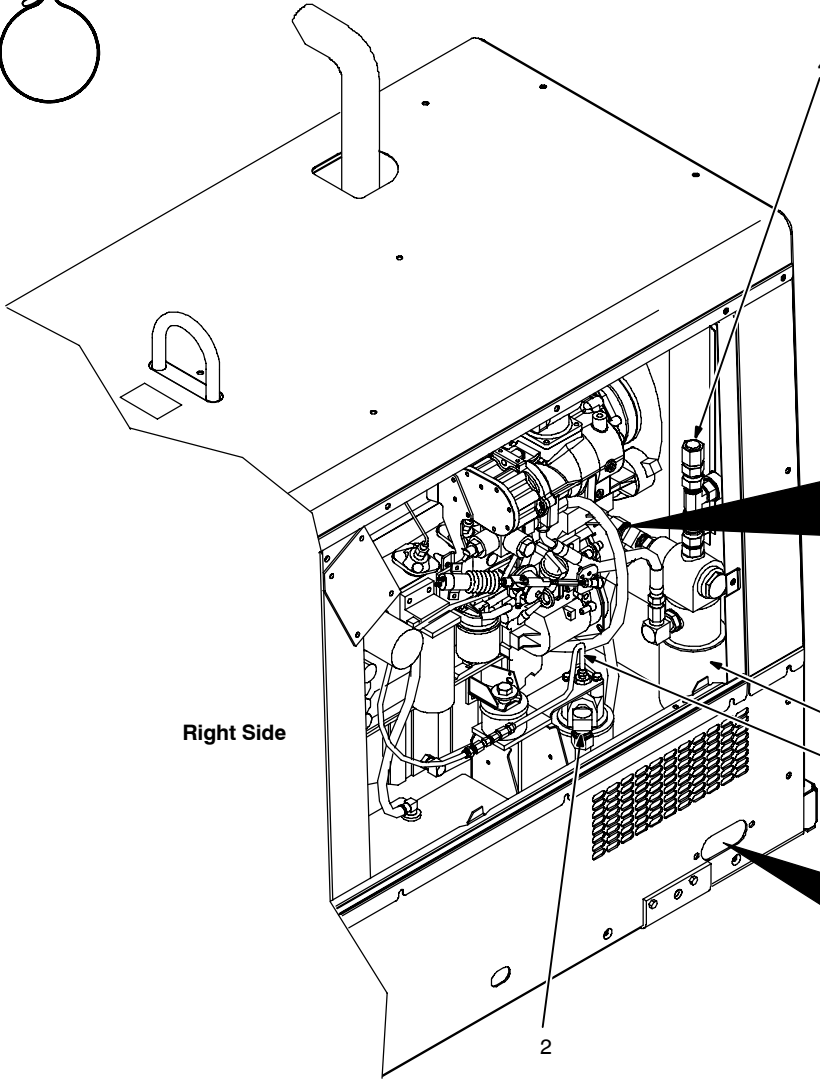
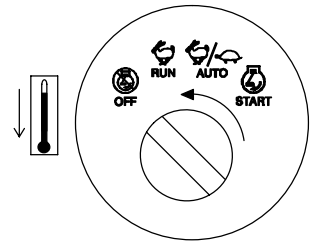
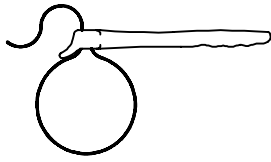

Right Side

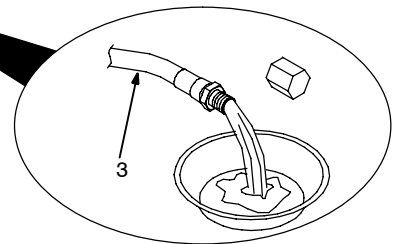
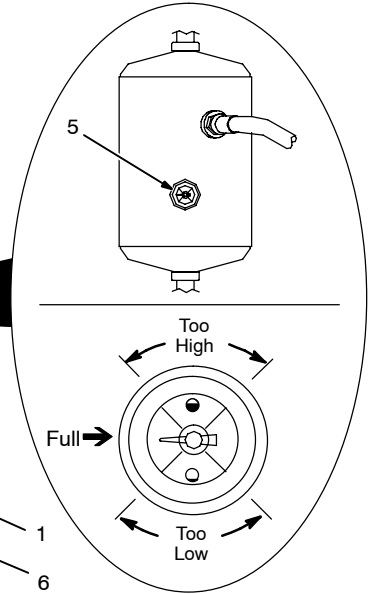

803 228

⚠ Stop engine and let cool. Wait 20 seconds for system pressure to drop before changing oil.

- 1 Air Compressor Oil Filter
- 2 Air Compressor Air/Oil Separator
- 3 Air Compressor Oil Drain Hose w/Removable Cap
- 4 Air Compressor Oil Fill Cap
- 5 Air Compressor Oil Level Indicator (On Tank)
- 6 Oil Scavenge Tube

To change compressor oil and filter:

☞ The engine oil drain and compressor oil drain hoses are located together in the base. Be sure to select the correct hose when draining compressor oil.

☞ Be sure o-rings at oil drain and oil fill fittings are in place before reinstalling caps.

Drain compressor oil while compressor is still warm.

Route compressor oil drain hose through hole in base. Remove compressor oil fill cap. Remove cap from oil drain hose and drain oil into a suitable container. Reinstall oil drain hose cap. Tighten cap with wrench.

Remove filter by turning filter counterclockwise. Remove filter. Apply thin coat of oil to gasket on new filter. Install new filter and turn clockwise until tight.

Add recommended oil until oil level indicator shows system is full (see compressor maintenance label for oil specifications). Reinstall oil fill cap. Tighten cap with wrench.

To replace air/oil separator:

Loosen nut securing tube on separator base. Lift oil scavenge tube from separator. Turn filter counterclockwise. Remove filter.

Apply thin coat of oil to gasket on new filter. Install filter and turn clockwise. Reinstall oil scavenge tube.

Start engine, run air compressor, and check for oil leaks.

⚠ Stop engine.

10-6. Adjusting Compressor Air Pressure

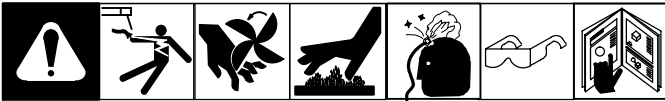

Tools Needed:

 5/16, 3/8 in

Check compressor air pressure using air pressure gauge known to be accurate. If necessary, adjust air pressure as follows:

1 Screw

Loosen jam nut securing screw. Turn screw clockwise (increase pressure) or counterclockwise (decrease) until pressure is 125 psi (862 kPa).

 *Maximum weld output is reduced if compressor air pressure is set above 125 psi (862 kPa).*

Tighten nut.

2 Pressure Relief Valve

Pressure relief valve opens and releases pressure at 150 psi (1034 kPa). The pressure relief valve is not adjustable.

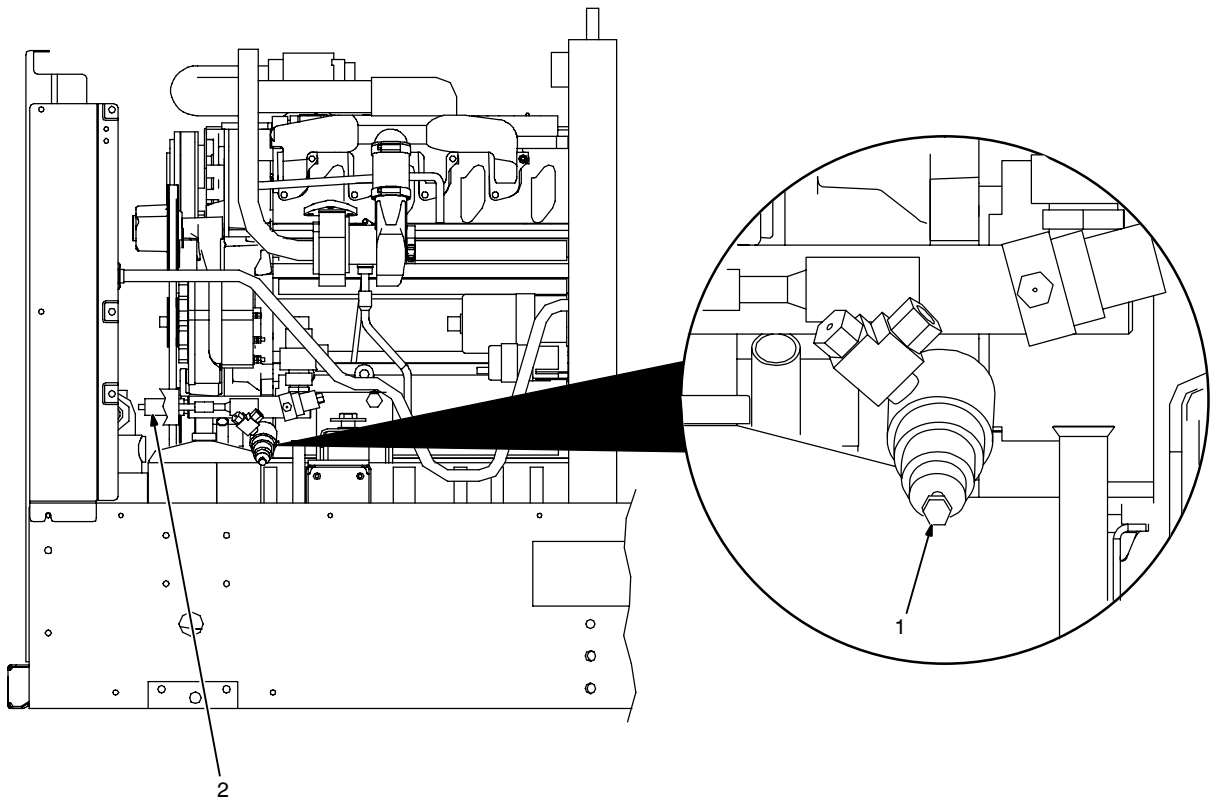

SECTION 11 – TROUBLESHOOTING

11-1. Troubleshooting Tables

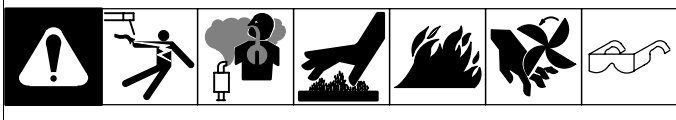

A. Welding

Trouble	Remedy
No weld output; generator power output okay at ac receptacles.	Place Process/Contactor switch in a Weld Terminals Always On position, or place switch in a Remote On/Off Switch Required position and connect remote contactor to Remote 14 receptacle RC14 (see Sections 5-10 and 6-1).
	Check position of Ampere Range switch.
	Check position of optional Output Selector switch (see Section 8-1).
	Reset supplementary protector CB11 (see Section 9-8).
	Reset supplementary protector CB5 (see Section 9-8). Check for faulty remote device connected to RC14.
	Check and secure connections to Remote 14 receptacle RC14 (see Section 5-10).
	Have Factory Authorized Service Agent check connector board PC6 and connections.
	Check fuse F2, and replace if open (see Section 9-8). Have Factory Authorized Service Agent check brushes and slip rings, field excitation circuit, field current regulator board PC1, and the rotor.
No weld output or generator power output.	Disconnect equipment from generator power receptacles during start-up.
	Check fuses F1 and F2, and replace if open (see Section 9-8). Have Factory Authorized Service Agent check integrated rectifier SR1, capacitor C9, field current regulator board PC1, and the rotor.
	Reset supplementary protector CB12 (see Section 9-8).
	Have Factory Authorized Service Agent check brushes and slip rings, and field excitation circuit.
Erratic weld output.	Check and tighten connections inside and outside unit.
	Be sure connection to work piece is clean and tight.
	Use dry, properly stored electrodes.
	Remove excessive coils from weld cables.
High weld output.	Check position of Ampere Range switch and Voltage/Amperage Adjust control.
	Check engine weld/power speed, and adjust if necessary (see Section 9-6).
	Have Factory Authorized Service Agent check field current regulator board PC1.
Voltage/Amperage control does not work when welding in Stick mode.	Place Ampere Range switch in lower range. Voltage/Amperage control does not work with Ampere Range switch in highest range.
Low weld output.	Check engine weld/power speed, and adjust if necessary (see Section 9-6).
	Check fuses F1 and F2, and replace if open (see Section 9-8). Have Factory Authorized Service Agent check integrated rectifier SR1, capacitor C9, field current regulator board PC1, and the rotor.
Electrode sticks to the workpiece more frequently during low voltage (short arc length) conditions.	Circuit breaker CB4 may be open. CB4 automatically resets when the fault is corrected (see Section 9-8). Have Factory Authorized Service Agent check transformer T1 and integrated rectifiers SR4 and SR5.
	Have Factory Authorized Service Agent check optional battery charging relay CR7.
Low open-circuit voltage.	Check engine weld/power speed, and adjust if necessary.
No remote fine amperage or voltage control.	Place Panel/Remote Switch in Remote position.
	Check and secure connections to Remote 14 receptacle RC14 (see Section 5-10).
	Repair or replace remote control device.

Trouble	Remedy
Constant speed wire feeder does not work.	Reset supplementary protector(s) CB5 and CB13 (see Section 9-8).
	Check and secure connections to Remote 14 receptacle RC14 (see Section 5-10).
	Repair or replace wire feeder.
Low CV weld output.	Set Ampere Range switch to highest range.
Min or max CV weld output only.	Check position of Voltage/Amperage Adjust control and Panel/Remote Switch.
	Repair or replace remote control device.
	Have Factory Authorized Service Agent check field current regulator board PC1.

B. Standard Generator Power

Trouble	Remedy
No generator power output at ac receptacles; weld output okay.	Reset receptacle supplementary protectors.
No generator power or weld output.	Disconnect equipment from generator power receptacles during start-up.
	Check fuses F1 and F2, and replace if open (see Section 9-8). Have Factory Authorized Service Agent check integrated rectifier SR1, capacitor C9, diode/capacitor board D1/C1, and the rotor.
	Reset supplementary protector CB12. Have Factory Authorized Service Agent check field current regulator board PC1 (see Section 10-4).
	Have Factory Authorized Service Agent check brushes and slip rings, and field excitation circuit.
High output at generator power receptacles.	Check engine weld/power speed, and adjust if necessary (see Section 9-6).
	Have Factory Authorized Service Agent adjust field current resistor R3.
Low output at generator power receptacles.	Check engine weld/power speed, and adjust if necessary (see Section 9-6).
	Check fuse F1, and replace if open (see Section 9-8). Have Factory Authorized Service Agent check integrated rectifier SR1, resistor R3, and capacitor C9.

C. Optional AC Power Plant

Trouble	Remedy
No or low output at optional ac power plant/receptacle RC5.	Place Process/Contactor switch in Weld Terminals Always On - Stick position (see Section 6-3).
	Reset supplementary protector CB7 (see Section 7-2).
	Reset supplementary protector CB5 (see Section 9-8).
	Check engine weld/power speed, and adjust if necessary (see Section 9-6).
	Have Factory Authorized Service Agent check brushes and slip rings, and field current regulator board PC1.
High output at optional ac power plant/receptacle RC5.	Check engine weld/power speed, and adjust if necessary (see Section 9-6).
	Have Factory Authorized Service Agent check field current regulator board PC1.
Erratic output at optional ac power plant/receptacle RC5.	Have Factory Authorized Service Agent check brushes and slip rings, and field current regulator board PC1.

D. Engine

Trouble	Remedy
Engine will not crank.	Check battery, and replace if necessary.
	Check battery connections and tighten if necessary.
	Circuit breaker CB10 may be open. CB10 automatically resets when fault is corrected (see Section 9-8). Have Factory Authorized Service Agent check engine wiring harness and components.
	Check engine wiring harness plug connections.
	Turn optional battery disconnect switch to On position (see Section 5-6).
	Have Factory Authorized Service Agent check Engine Control switch S1, control relay CR1, and diode/capacitor board D8/C8.
Engine cranks but does not start.	Check fuel level. Optional low fuel shutdown stops engine if fuel level is low.
	Reset supplementary protector CB13 (see Section 10-4). Have Factory Authorized Service Agent check engine wiring harness and components.
	Check battery and replace if necessary. Check engine charging system according to engine manual.
	Have Factory Authorized Service Agent check time delay relay TD1, control relay CR5, fuel pump, and fuel solenoid FS1.
	Air in fuel system. See engine manual.
Engine starts, but stops when Engine Control switch is released.	Check oil level. Automatic shutdown system stops engine if oil pressure is too low or engine temperature is too high (see Section 5-7).
	Have Factory Authorized Service Agent check time delay relay TD1, and control relay CR5.
Engine hard to start in cold weather.	Use starting aid switch (see Section 6-1). If Starting Aid switch does not work have Factory Authorized Service Agent check Engine Control switch S2, and control relay CR8.
	Keep battery in good condition. Store battery in warm area off cold surface.
	Use fuel formulated for cold weather (diesel fuel can gel in cold weather). Contact local fuel supplier for fuel information.
	Use correct grade oil for cold weather (see Section 9-1).
Engine suddenly stops.	Check fuel level. Optional low fuel shutdown stops engine if fuel level is low.
	Check oil level. Automatic shutdown system stops engine if oil pressure is too low or engine temperature is too high (see Section 5-7).
	Have Factory Authorized Service Agent check time delay relay TD1, control relay CR5, fuel pump, and fuel solenoid FS1.
	See engine manual.
Engine slowly stopped and cannot be restarted.	Check fuel level.
	Check engine air and fuel filters (see Sections 9-4 and 9-7).
	See engine manual.
Battery discharges between uses.	Turn Engine Control switch S1 off when unit is not running.
	Clean top of battery with baking soda and water solution; rinse with clear water.
	Recharge or replace battery if necessary.
	Periodically recharge battery (approximately every 3 months).
Engine idles, but does not come up to weld speed.	Have Factory Authorized Service Agent check idle module PC7.
	Check for obstructed throttle solenoid.

Trouble	Remedy
Engine does not run at idle speed.	Turn Process/Contactor switch to any position but Remote On/Off Switch Required-TIG.
	Check for obstructed throttle solenoid.
	Allow circuit breaker CB14 to reset. Have Factory Authorized Service Agent check throttle solenoid TS1 and linkage (see Section 9-8).
	Have Factory Authorized Service Agent check idle module PC7, control relays CR3 and CR6, and current transformer CT1.
Engine uses oil during run-in period; wetstacking occurs.	Dry engine (see Section 14).

E. Air Compressor

Trouble	Remedy
Air compressor does not operate; no air pressure at air shutoff valve.	Place Air Compressor switch in On position. The air compressor will not start if still under pressure. If compressor is turned off, wait for air pressure to bleed off (about 20 seconds) before turning compressor on again.
	Reset supplementary protector CB15 (see Section 10-4).
	Check compressor belt tension. Be sure correct belt is used and is properly installed.
	Have Factory Authorized Service Agent check Air Compressor switch S10, control relay CR10, air pressure switch S11, temperature switch S12, compressor control circuit, and air compressor clutch.
Air compressor stops after short period of operation.	Check compressor oil level (see Section 5-7). Automatic shutdown stops compressor if compressor temperature is too high.
	Clean debris from radiator. Automatic shutdown stops compressor if compressor temperature is too high.
Low air pressure.	Check for leaks in air lines and hoses.
	Adjust compressor air pressure (see Section 10-6).
	Check air compressor air cleaner (see Section 10-3).
	Have Factory Authorized Service Agent check compressor for rated output.
High air pressure.	Adjust compressor air pressure (see Section 10-6).
	Be sure control line is connected at regulator valve and inlet valve.
Pneumatic tools freeze up because of moisture in compressed air.	Install optional air dryer/filter kit (Part No. 195 117).
Oil in air from compressor.	Check compressor oil level (see Section 5-7). If oil level is too high, system becomes saturated with oil.
	Change compressor air/oil separator (see Section 10-5).
	Check connections of control lines (see air compressor circuit diagram in Section 12).
	Have Factory Authorized Service Agent check for blocked separator scavenge check valve/filter orifice.
Oil in compressor air cleaner.	Have Factory Authorized Service Agent verify compressor inlet valve is operating properly.

F. Optional Battery Charging

Trouble	Remedy
No battery charge output; weld output okay.	Place Output Selector switch in 12 Volt Charge or 24 Volt Charge position.
	Check and tighten battery connections if necessary.
	Turn on remote control device or turn Process/Contactor switch to any Weld Terminals Always On position (see Section 6-3).
No battery charge or weld output.	Disconnect equipment from generator power receptacles during start-up.
	Check fuses F1 and F2, and replace if open (see Section 9-8). Have Factory Authorized Service Agent check integrated rectifier SR1, capacitor C9, field current regulator board PC1, and the rotor.
	Reset supplementary protector CB12 (see Section 9-8).
	Have Factory Authorized Service Agent check brushes and slip rings, field current regulator board PC1, and field excitation circuit.

SECTION 12 – AIR COMPRESSOR DIAGRAM

	WARNING
	<ul style="list-style-type: none"> • Do not touch live electrical parts. • Disconnect input power or stop engine before servicing. • Do not operate with covers removed. • Have only qualified persons install, use, or service this unit.
ELECTRIC SHOCK HAZARD	

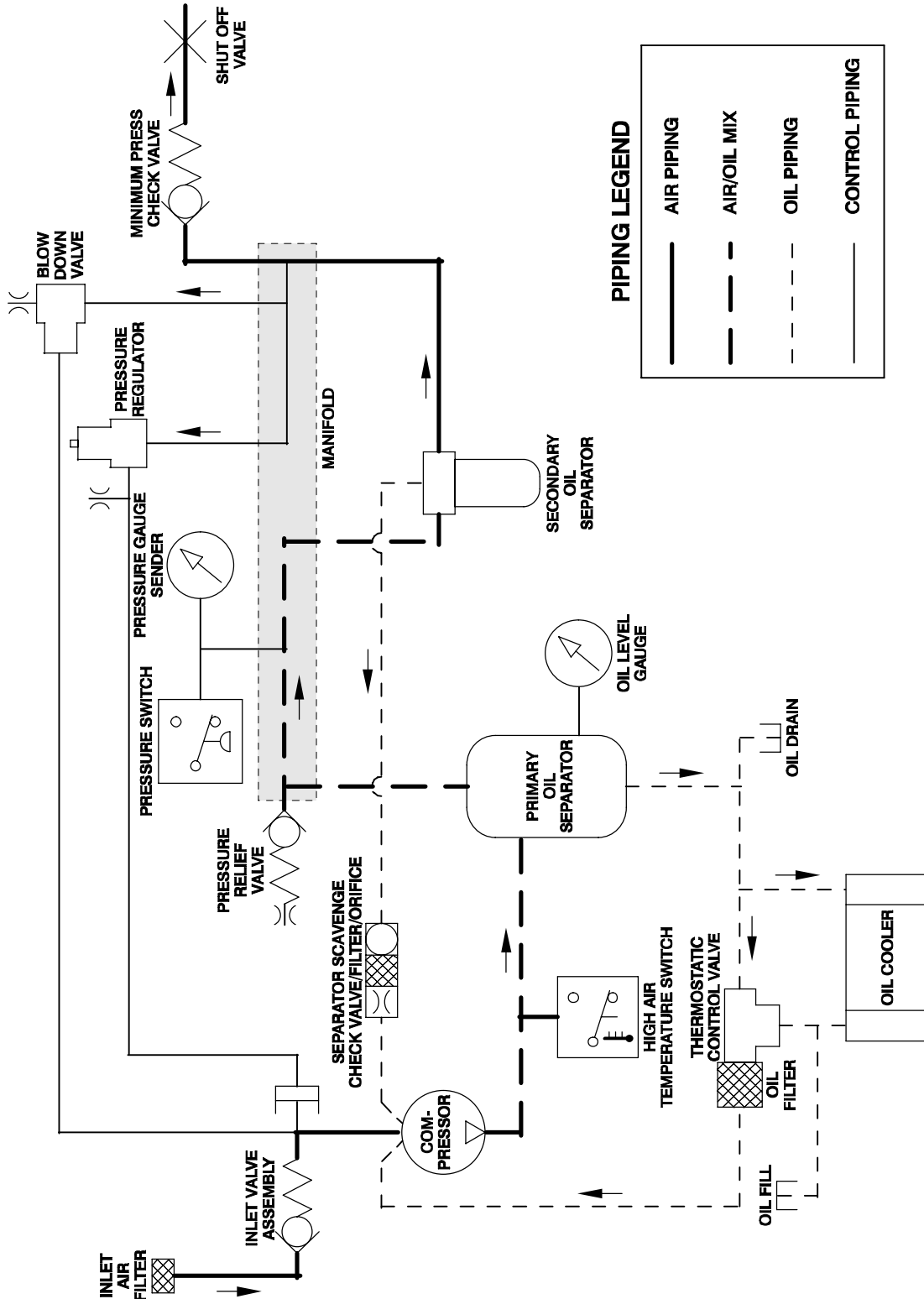

Figure 12-1. Circuit Diagram For Air Compressor

SECTION 13 – CIRCUIT DIAGRAM

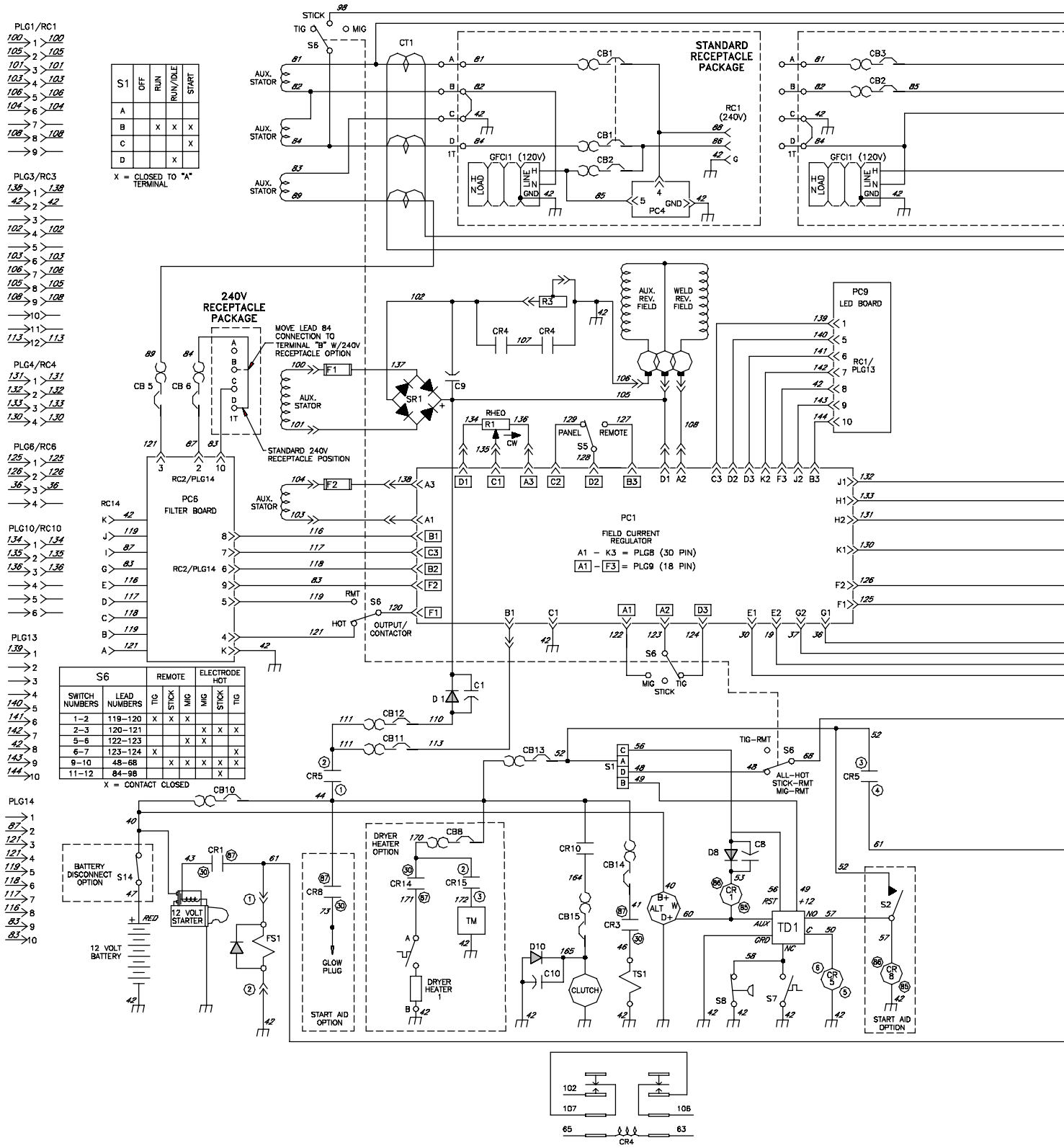
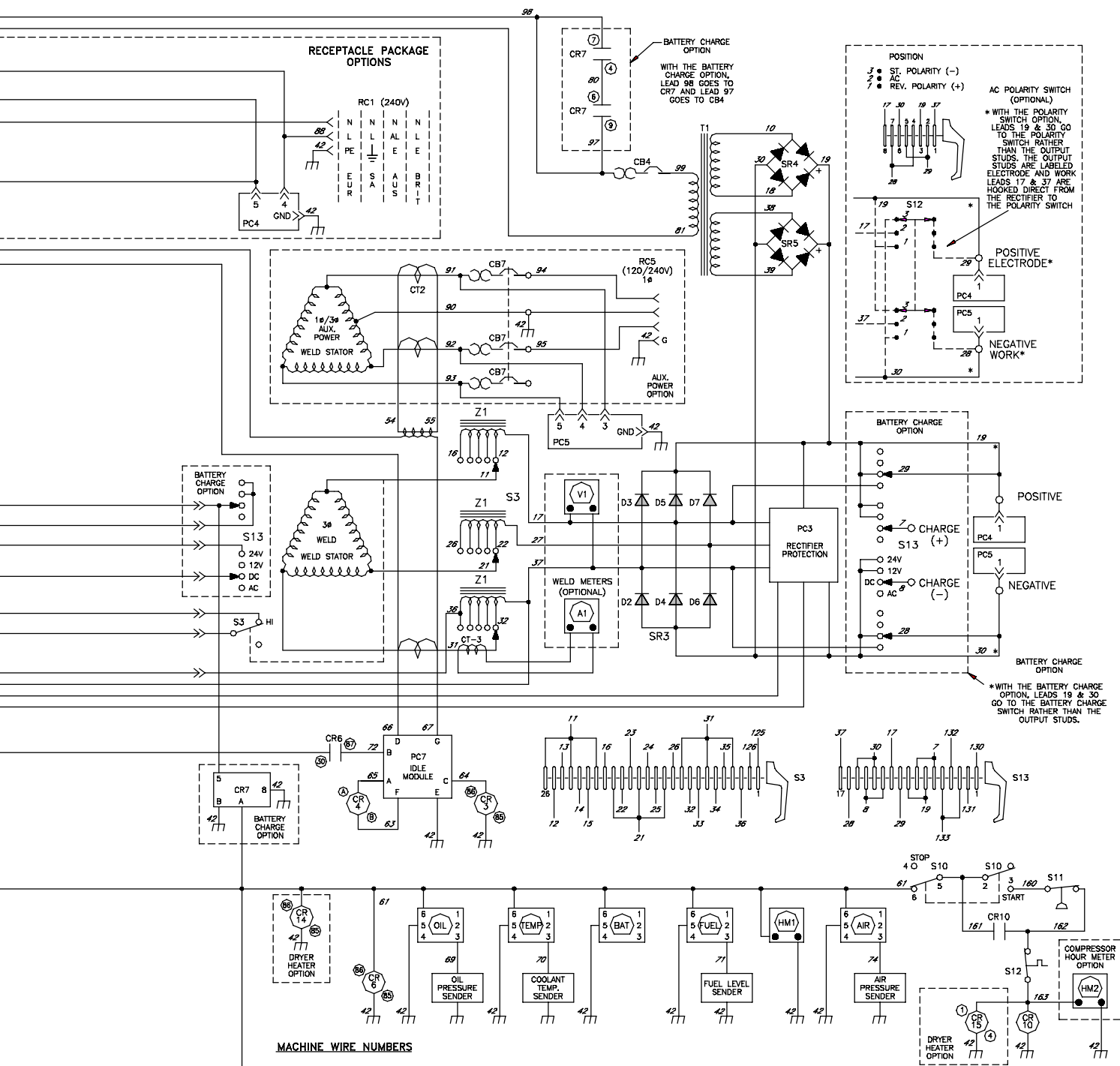

Figure 13-1. Circuit Diagram For Welding Generator



SECTION 14 – RUN-IN PROCEDURE

run_in1 2007-04

14-1. Wetstacking

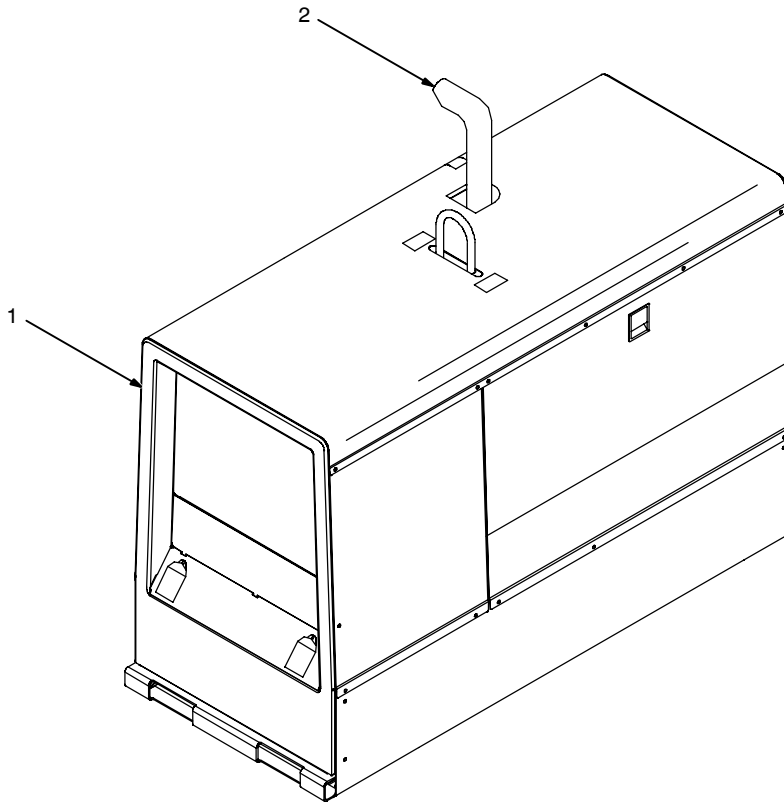

NOTICE – Do not perform run-in procedure at less than 20 volts weld output and do not exceed duty cycle or equipment damage may occur.

1 Welding Generator

Run diesel engines near rated voltage and current during run-in period to properly seat piston rings and prevent wetstacking. See nameplate, rating label, or specifications section in this manual to find rated voltage and current.

NOTICE – Do not idle engine longer than necessary. Piston rings seat faster if engine runs at weld/power rpm, and the welding generator is kept loaded during run-in.

2 Engine Exhaust Pipe

Wetstacking is unburned fuel and oil in the exhaust pipe and occurs during run-in if the engine is run too long at light load or idle rpm.

If exhaust pipe is coated with a wet, black, tar-like substance, dry the engine using one of the following run-in procedures.

See the engine manual for additional engine run-in information.

14-2. Run-In Procedure Using Load Bank

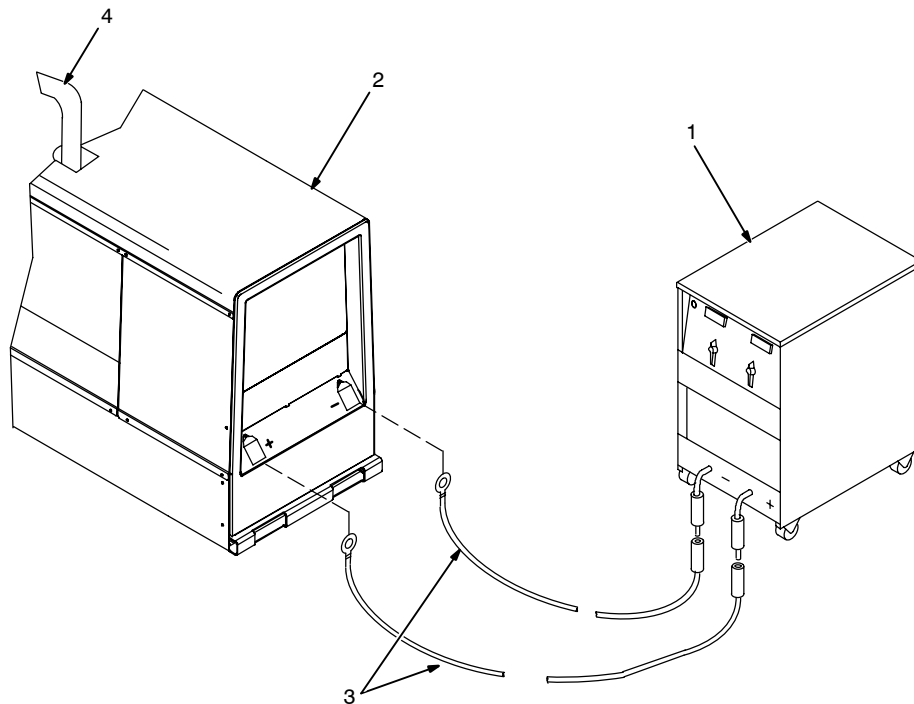

- ⚠ Stop engine.**
- ⚠ Do not touch hot exhaust pipe, engine parts, or load bank/grid.**
- ⚠ Keep exhaust and pipe away from flammables.**

NOTICE – Do not perform run-in procedure at less than 20 volts weld output and do not exceed duty cycle or equipment damage may occur.

1 Load Bank

Turn all load bank switches Off. If needed, connect load bank to 115 volts ac wall receptacle or generator auxiliary power receptacle.

2 Welding Generator

Place A/V range switch in maximum position, A/V control in minimum position, and Output Selector switch (if present) in either DC position.

3 Weld Cables

Connect load bank to generator weld output terminals using proper size weld cables with correct connectors. Observe correct polarity.

Start engine and run for several minutes.

Set load bank switches and then adjust generator A/V control so load equals rated voltage and current of generator (see nameplate, rating label, or the specifications section in this manual).

Check generator and load bank meters after first five minutes then every fifteen minutes to be sure generator is loaded properly.

NOTICE – Check oil level frequently during run-in; add oil if needed.

It is recommended to run the welding generator for two hours minimum and up to four hours under load. Place A/V control in minimum position, then turn off load bank to remove load. Run engine several minutes at no load.

- ⚠ Stop engine and let cool.**

4 Engine Exhaust Pipe

Repeat procedure if wetstacking is present.

14-3. Run-In Procedure Using Resistance Grid

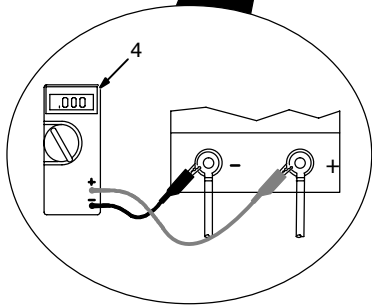
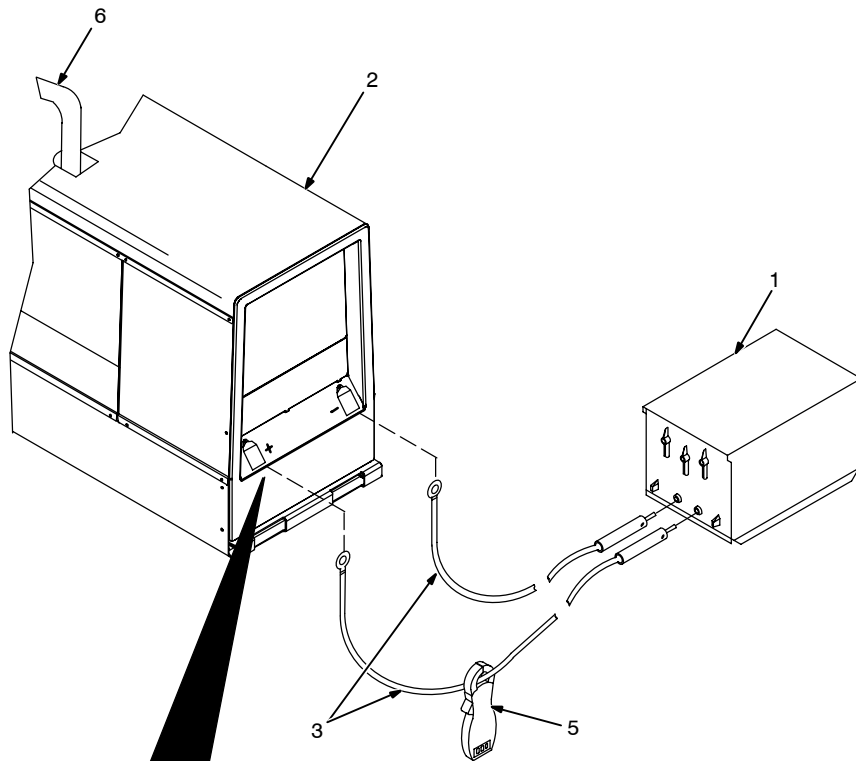

- ⚠ **Stop engine.**
- ⚠ **Do not touch hot exhaust pipe, engine parts, or load bank/grid.**
- ⚠ **Keep exhaust and pipe away from flammables.**

NOTICE – Do not perform run-in procedure at less than 20 volts weld output and do not exceed duty cycle or equipment damage may occur.

1 Resistance Grid

Use grid sized for generator rated output.

Turn Off grid.

2 Welding Generator

Place A/V range switch in maximum position, A/V control in minimum position, and Output Selector switch (if present) in either DC position.

3 Weld Cables

Connect grid to generator weld output terminals using proper size weld cables with correct connectors (polarity is not important).

4 Voltmeter

5 Clamp-On Ammeter

Connect voltmeter and ammeter as shown, if not provided on generator.

Start engine and run for several minutes.

Set grid switches and then adjust generator A/V control so load equals rated voltage and current of the generator (see nameplate, rating label, or the specifications section in this manual).

Check generator and meters after first five minutes then every fifteen minutes to be sure generator is loaded properly.

NOTICE – Check oil level frequently during run-in; add oil if needed.

It is recommended to run the welding generator for two hours minimum and up to four hours under load. Place A/V control in minimum position, then shut down grid to remove load. Run engine several minutes at no load.

- ⚠ **Stop engine and let cool.**

6 Engine Exhaust Pipe

Repeat procedure if wetstacking is present.

SECTION 15 – AIR COMPRESSOR TABLES

15-1. Flow Of Free Air (CFM) Through Orifices Of Various Diameters

Gauge Pressure (psi)	Orifice Diameter (in) And Free Air Flow (CFM)							
	1/64	1/32	3/64	1/16	3/32	1/8	3/16	1/4
1	0.027	0.107	0.242	0.430	0.97	1.72	3.86	6.85
2	0.038	0.153	0.342	0.607	1.36	2.43	5.42	9.74
3	0.046	0.188	0.471	0.750	1.68	2.98	6.71	11.9
5	0.059	0.242	0.545	0.965	2.18	3.86	8.71	15.4
10	0.084	0.342	0.77	1.36	3.08	5.45	12.3	21.8
15	0.103	0.418	0.94	1.67	3.75	6.65	15.0	26.7
20	0.119	0.485	1.07	1.93	4.25	7.7	17.1	30.8
25	0.133	0.54	1.21	2.16	4.75	8.6	19.4	34.5
30	0.156	0.632	1.40	2.52	5.6	10.0	22.5	40.0
35	0.173	0.71	1.56	2.80	6.2	11.2	25.0	44.7
40	0.19	0.77	1.71	3.07	6.8	12.3	27.3	49.1
45	0.208	0.843	1.9	3.36	7.6	13.4	30.3	53.8
50	0.225	9.14	2.05	3.64	8.2	14.5	32.8	58.2
60	0.26	1.05	2.35	4.2	9.4	16.8	37.5	67.0
70	0.295	1.19	2.68	4.76	10.7	19.0	43.0	76.0
80	0.33	1.33	2.97	5.32	11.9	21.2	47.5	85.0
90	0.364	1.47	3.28	5.87	13.1	23.5	52.5	94.0
100	0.40	1.61	3.66	6.45	14.5	25.8	58.3	103.0
110	0.43	1.76	3.95	7.00	15.7	28.0	63.0	112.0
120	0.47	1.90	4.27	7.58	17.0	30.2	68.0	121.0
130	0.50	2.04	4.57	8.13	18.2	32.4	73.0	130.0
140	0.54	2.17	4.87	8.68	19.5	34.5	78.0	138.0
150	0.57	2.33	5.2	9.20	20.7	36.7	83.0	147.0
175	0.66	2.65	5.94	10.6	23.8	42.1	95.0	169.0
200	0.76	3.07	6.90	12.2	27.5	48.7	110.0	195.0

15-2. Approximate Air Consumption (Cubic Feet) To Operate Pneumatic Equipment At 70-90 P.S.I.G.

MISCELLANEOUS PORTABLE TOOLS	Percent Use Factor And Compressed Air Consumption (CF)				MISCELLANEOUS PORTABLE TOOLS	Percent Use Factor And Compressed Air Consumption (CF)			
	9 sec	15 sec	21 sec	1 min		9 sec	15 sec	21 sec	1 min
Drill, 1/18" to 3/8"	3.75	6.25	8.75	25	Burring Tool, Large	3.6	6.0	8.4	24
Drill, 3/8" to 5/16"	5.25	8.75	12.25	35	Rammers, Small	3.9	3.25	9.1	13
Screwdriver, #2 to #6 Screw	1.8	3.0	4.2	12	Rammers, Medium	5.1	8.5	11.9	34
Screwdriver, #6 to 5/16" Screw	3.6	6.0	8.4	24	Rammers, Large	6.0	10.0	14.0	40
Tapper, to 3/8"	3.0	5.0	7.0	20	Backfill Tamper	3.75	6.25	8.75	25
Nutsetters, to 3/8"	3.6	6.0	8.4	24	Compression Riveter	0.2 cu. ft. per cycle			
Nutsetters, to 3/4"	4.5	7.5	10.5	30	Air Motor, 1 Horsepower	3.75	6.3	8.75	25
Impact Wrench, 1/4"	2.25	3.75	5.3	15	Air Motor, 2 Horsepower	7.5	12.5	17.5	50
Impact Wrench, 3/8"	3.0	5.0	7.0	20	Air Motor, 3 Horsepower	11.25	18.75	26.3	75
Impact Wrench, 5/8"	4.5	7.5	10.5	30	Paint Spray Gun (Production)	3.0	5.00	7.00	20
Impact Wrench, 3/4"	5.25	8.75	12.25	35	,HAMMERS				
Impact Wrench, 1"	6.75	11.25	15.75	45	Scaling Hammer	1.3	3.0	4.2	12
Impact Wrench, 1-1/4"	8.25	13.75	19.2	55	Chipping Hammer	4.5	7.5	10.5	30
Die Grinder, Small	2.25	3.75	5.3	15	Riveting Hammer, Light	2.25	3.75	5.25	15
Die Grinder, Medium	3.6	6.0	8.4	24	Riveting Hammer, Heavy	4.5	7.5	10.5	30
Horizontal Grinder, 2"	3.0	5.0	7.0	20	SAWS				
Horizontal Grinder, 4"	9.0	15.0	21.0	60	Circular, 8"	6.75	11.25	15.75	45
Horizontal Grinder, 6"	9.0	15.0	21.0	60	Circular, 12"	9.75	16.25	23.8	65
Horizontal Grinder, 8"	12.0	20.0	28.0	80	Chain, Lightweight	4.20	7.0	9.8	28
Vertical Grinders and Sanders, 5" Pad	5.25	8.75	12.25	35	Chain, Heavy Duty	13.1	21.8	30.5	87
Vertical Grinders and Sanders, 7" Pad	9.0	15.0	21.0	60					
Vertical Grinders and Sanders, 9" Pad	10.5	17.5	24.5	70					
Burring Toll, Small	2.25	3.75	5.3	15					

Always check with tool manufacturers for actual air consumption of tools being used. The above is based on averages and should not be considered accurate for any particular make of tool.

Above tools are rated based upon typical "on-load" performance characteristics.



For other values, adjust the C.F. air consumption on a proportional basis.

The cubic feet (C.F.) air consumption for 1 minute may also be expressed as air consumption in cubic feet per minute (C.F.M.)

SECTION 16 – GENERATOR POWER GUIDELINES

The views in this section are intended to be representative of all engine-driven welding generators. Your unit may differ from those shown.

16-1. Selecting Equipment



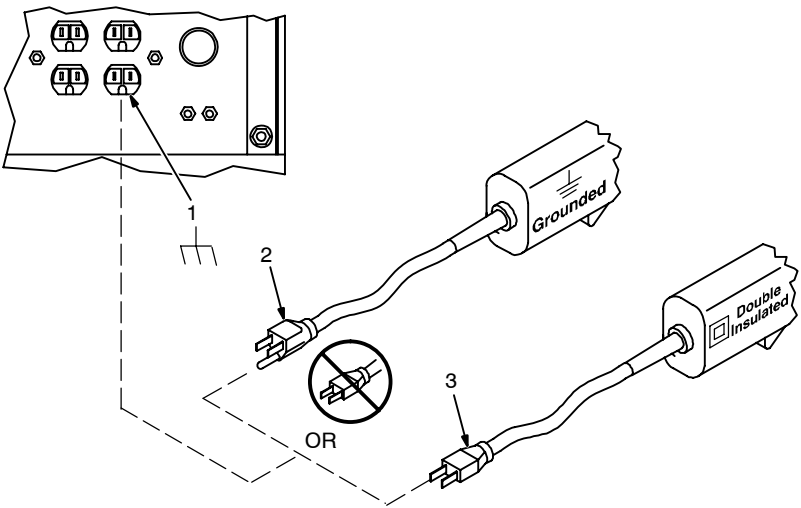

- 1 Generator Power Receptacles – Neutral Bonded To Frame
- 2 3-Prong Plug From Case Grounded Equipment
- 3 2-Prong Plug From Double Insulated Equipment

Be sure equipment has double insulated symbol and/or wording on it.

Do not use 2-prong plug unless equipment is double insulated.

gen_pwr 2007-04 – Ref. ST-159 730 / ST-800 577

16-2. Grounding Generator To Truck Or Trailer Frame

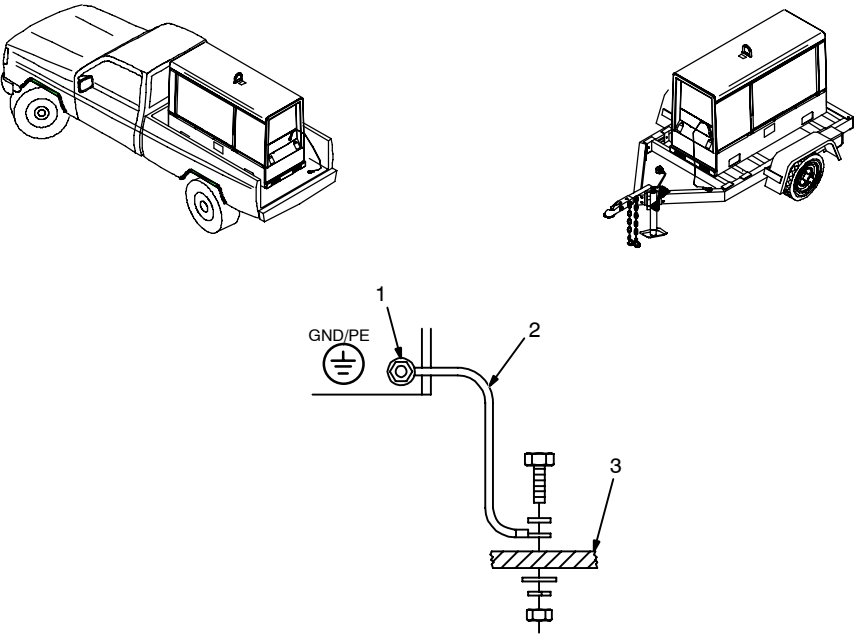

Always ground generator frame to vehicle frame to prevent electric shock and static electricity hazards.

Also see AWS Safety & Health Fact Sheet No. 29, Grounding of Portable And Vehicle Mounted Welding Generators.

- 1 Equipment Grounding Terminal (On Front Panel)
- 2 Grounding Cable (Not Supplied)
- 3 Metal Vehicle Frame

Connect cable from equipment ground terminal to metal vehicle frame. Use #10 AWG or larger insulated copper wire.

Electrically bond generator frame to vehicle frame by metal-to-metal contact.

Bed liners, shipping skids, and some running gear insulate the welding generator from the vehicle frame. Always connect a ground wire from the generator equipment grounding terminal to bare metal on the vehicle frame as shown.

If unit does not have GFCI receptacles, use GFCI-protected extension cord.

S-0854

16-3. Grounding When Supplying Building Systems

1 Equipment Grounding Terminal
 2 Grounding Cable
 Use #10 AWG or larger insulated copper wire.
 3 Ground Device

Use ground device as stated in electrical codes.

Ground generator to system earth ground if supplying power to a premises (home, shop, farm) wiring system.

Also see AWS Safety & Health Fact Sheet No. 29, Grounding of Portable And Vehicle Mounted Welding Generators.

ST-800 576-B

16-4. How Much Power Does Equipment Require?

1 Resistive Load
 A light bulb is a resistive load and requires a constant amount of power.

2 Non-Resistive Load
 Equipment with a motor is a non-resistive load and requires approximately six times more power while starting the motor than when running (see Section 16-8).

3 Rating Data
 Rating shows volts and amperes, or watts required to run equipment.

Amperes x Volts = Watts

Example 1: If a drill uses 4.5 amperes at 115 volts, calculate its running power requirement in watts.
 $4.5 \text{ A} \times 115 \text{ V} = 520 \text{ W}$
 The load applied by the drill is 520 watts.

Example 2: If three 200 watt flood lamps are used with the drill from Example 1, add the individual loads to calculate total load.
 $(3 \times 200\text{W}) + 520 \text{ W} = 1120 \text{ W}$
 The total load applied by the three flood lamps and drill is 1120 watts.

S-0623

16-5. Approximate Power Requirements For Industrial Motors

Industrial Motors	Rating	Starting Watts	Running Watts
Split Phase	1/8 HP	800	300
	1/6 HP	1225	500
	1/4 HP	1600	600
	1/3 HP	2100	700
	1/2 HP	3175	875
Capacitor Start-Induction Run	1/3 HP	2020	720
	1/2 HP	3075	975
	3/4 HP	4500	1400
	1 HP	6100	1600
	1-1/2 HP	8200	2200
	2 HP	10550	2850
	3 HP	15900	3900
Capacitor Start-Capacitor Run	5 HP	23300	6800
	1-1/2 HP	8100	2000
	5 HP	23300	6000
	7-1/2 HP	35000	8000
Fan Duty	10 HP	46700	10700
	1/8 HP	1000	400
	1/6 HP	1400	550
	1/4 HP	1850	650
	1/3 HP	2400	800
	1/2 HP	3500	1100

16-6. Approximate Power Requirements For Farm/Home Equipment

Farm/Home Equipment	Rating	Starting Watts	Running Watts
Stock Tank De-Icer		1000	1000
Grain Cleaner	1/4 HP	1650	650
Portable Conveyor	1/2 HP	3400	1000
Grain Elevator	3/4 HP	4400	1400
Milk Cooler		2900	1100
Milker (Vacuum Pump)	2 HP	10500	2800
FARM DUTY MOTORS	1/3 HP	1720	720
Std. (e.g. Conveyors,	1/2 HP	2575	975
Feed Augers, Air	3/4 HP	4500	1400
Compressors)	1 HP	6100	1600
	1-1/2 HP	8200	2200
	2 HP	10550	2850
	3 HP	15900	3900
	5 HP	23300	6800
High Torque (e.g. Barn	1-1/2 HP	8100	2000
Cleaners, Silo Unloaders,	5 HP	23300	6000
Silo Hoists, Bunk Feeders)	7-1/2 HP	35000	8000
	10 HP	46700	10700
3-1/2 cu. ft. Mixer	1/2 HP	3300	1000
High Pressure 1.8 Gal/Min	500 PSI	3150	950
Washer 2 gal/min	550 PSI	4500	1400
2 gal/min	700 PSI	6100	1600
Refrigerator or Freezer		3100	800
Shallow Well Pump	1/3 HP	2150	750
	1/2 HP	3100	1000
Sump Pump	1/3 HP	2100	800
	1/2 HP	3200	1050

16-7. Approximate Power Requirements For Contractor Equipment

Contractor	Rating	Starting Watts	Running Watts
Hand Drill	1/4 in	350	350
	3/8 in	400	400
	1/2 in	600	600
Circular Saw	6-1/2 in	500	500
	7-1/4 in	900	900
	8-1/4 in	1400	1400
Table Saw	9 in	4500	1500
	10 in	6300	1800
Band Saw	14 in	2500	1100
Bench Grinder	6 in	1720	720
	8 in	3900	1400
	10 in	5200	1600
Air Compressor	1/2 HP	3000	1000
	1 HP	6000	1500
	1-1/2 HP	8200	2200
	2 HP	10500	2800
Electric Chain Saw	1-1/2 HP, 12 in	1100	1100
	2 HP, 14 in	1100	1100
Electric Trimmer	Standard 9 in	350	350
	Heavy Duty 12 in	500	500
Electric Cultivator	1/3 HP	2100	700
Elec. Hedge Trimmer	18 in	400	400
Flood Lights	HID	125	100
	Metal Halide	313	250
	Mercury	1000	
	Sodium Vapor	1400	1000
Submersible Pump	400 gph	600	200
Centrifugal Pump	900 gph	900	500
Floor Polisher	3/4 HP, 16 in	4500	1400
	1 HP, 20 in	6100	1600
High Pressure Washer	1/2 HP	3150	950
	3/4 HP	4500	1400
	1 HP	6100	1600
55 gal Drum Mixer	1/4 HP	1900	700
Wet & Dry Vac	1.7 HP	900	900
	2-1/2 HP	1300	1300

16-8. Power Required To Start Motor

Single-Phase Induction Motor Starting Requirements								
Motor Start Code	G	H	J	K	L	M	N	P
KVA/HP	6.3	7.1	8.0	9.0	10.0	11.2	12.5	14.0

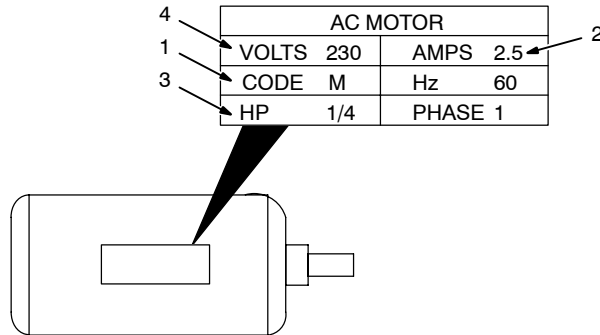

- 1 Motor Start Code
- 2 Running Amperage
- 3 Motor HP
- 4 Motor Voltage

To find starting amperage:

Step 1: Find code and use table to find kVA/HP. If code is not listed, multiply running amperage by six to find starting amperage.

Step 2: Find Motor HP and Volts.

Step 3: Determine starting amperage (see example).

Welding generator amperage output must be at least twice the motor's running amperage.

$$\frac{(\text{kVA/HP} \times \text{HP} \times 1000)}{\text{Volts}} = \text{Starting Amperage}$$

Example: Calculate starting amperage required for a 230 V, 1/4 HP motor with a motor start code of M.

Volts = 230, HP = 1/4, kVA/HP = 11.2

$$(11.2 \times 1/4 \times 1000) / 230 = 12.2\text{A}$$

Starting the motor requires 12.2 amperes.

S-0624

16-9. How Much Power Can Generator Supply?

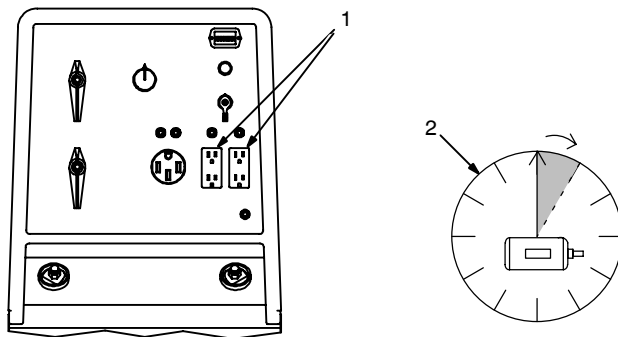

- 1 Limit Load To 90% Of Generator Output

Always start non-resistive (motor) loads in order from largest to smallest, and add resistive loads last.

- 2 5 Second Rule

If motor does not start within 5 seconds, turn off power to prevent motor damage. Motor requires more power than generator can supply.

Ref. ST-800 396-A / S-0625

16-10. Typical Connections To Supply Standby Power

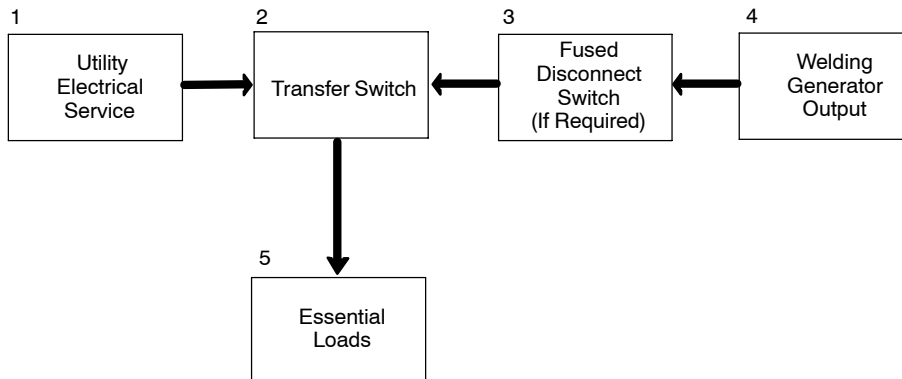

⚠ Have only qualified persons perform these connections according to all applicable codes and safety practices.

⚠ Properly install and ground this equipment according to its Owner's Manual and national, state, and local codes.

📖 *Customer-supplied equipment is required if generator will supply standby power during emergencies or power outages.*

1 Utility Electrical Service

2 Transfer Switch (Double-Throw)

Switch transfers the electrical load from electric utility service to the generator. Transfer load back to electric utility when service is restored.

Install correct switch (customer-supplied). Switch rating must be same as or greater than the branch overcurrent protection.

3 Fused Disconnect Switch

Install correct switch (customer-supplied) if required by electrical code.

4 Welding Generator Output

Generator output voltage and wiring must be consistent with regular (utility) system voltage and wiring.

Connect generator with temporary or permanent wiring suitable for the installation.

Turn off or unplug all equipment connected to generator before starting or stopping engine. When starting or stopping, the engine has low speed which causes low voltage and frequency.

5 Essential Loads

Generator output may not meet the electrical requirements of the premises. If generator does not produce enough output to meet all requirements, connect only essential loads (pumps, freezers, heaters, etc. – See Section 16-4).

16-11. Selecting Extension Cord (Use Shortest Cord Possible)



Cord Lengths for 120 Volt Loads							
 If unit does not have GFCI receptacles, use GFCI-protected extension cord.							
Current (Amperes)	Load (Watts)	Maximum Allowable Cord Length in ft (m) for Conductor Size (AWG)*					
		4	6	8	10	12	14
5	600			350 (106)	225 (68)	137 (42)	100 (30)
7	840		400 (122)	250 (76)	150 (46)	100 (30)	62 (19)
10	1200	400 (122)	275 (84)	175 (53)	112 (34)	62 (19)	50 (15)
15	1800	300 (91)	175 (53)	112 (34)	75 (23)	37 (11)	30 (9)
20	2400	225 (68)	137 (42)	87 (26)	50 (15)	30 (9)	
25	3000	175 (53)	112 (34)	62 (19)	37 (11)		
30	3600	150 (46)	87 (26)	50 (15)	37 (11)		
35	4200	125 (38)	75 (23)	50 (15)			
40	4800	112 (34)	62 (19)	37 (11)			
45	5400	100 (30)	62 (19)				
50	6000	87 (26)	50 (15)				



*Conductor size is based on maximum 2% voltage drop

Cord Lengths for 240 Volt Loads							
 If unit does not have GFCI receptacles, use GFCI-protected extension cord.							
Current (Amperes)	Load (Watts)	Maximum Allowable Cord Length in ft (m) for Conductor Size (AWG)*					
		4	6	8	10	12	14
5	1200			700 (213)	450 (137)	225 (84)	200 (61)
7	1680		800 (244)	500 (152)	300 (91)	200 (61)	125 (38)
10	2400	800 (244)	550 (168)	350 (107)	225 (69)	125 (38)	100 (31)
15	3600	600 (183)	350 (107)	225 (69)	150 (46)	75 (23)	60 (18)
20	4800	450 (137)	275 (84)	175 (53)	100 (31)	60 (18)	
25	6000	350 (107)	225 (69)	125 (38)	75 (23)		
30	7000	300 (91)	175 (53)	100 (31)	75 (23)		
35	8400	250 (76)	150 (46)	100 (31)			
40	9600	225 (69)	125 (38)	75 (23)			
45	10,800	200 (61)	125 (38)				
50	12,000	175 (53)	100 (31)				

*Conductor size is based on maximum 2% voltage drop

SECTION 17 – SELECTING AND PREPARING A TUNGSTEN FOR DC OR AC WELDING

gtaw_Phase_2007-04

   Whenever possible and practical, use DC weld output instead of AC weld output.



17-1. Selecting Tungsten Electrode (Wear Clean gloves To Prevent Contamination Of Tungsten)

Electrode Diameter	Amperage Range - Gas Type ♦ - Polarity	
	(DCEN) – Argon Direct Current Electrode Negative (For Use With Mild Or Stainless Steel)	AC – Argon Balance Control @ 65% Electrode Negative (For Use With Aluminum)
2% Ceria (Orange Band), 1.5% Lanthanum (Gray Band), Or 2% Thorium (Red Band) Alloy Tungstens		
.040" (1 mm)	25-85	20-80
1/16" (1.6 mm)	50-160	50-150
3/32" (2.4 mm)	135-235	130-250
1/8" (3.2 mm)	250-400	225-360
Pure Tungsten (Green Band)		
.040" (1 mm)	Pure Tungsten Not Recommended For DCEN – Argon	10-60
1/16" (1.6 mm)		50-100
3/32" (2.4 mm)		100-160
1/8" (3.2 mm)		150-210

♦ Typical argon shielding gas flow rates are 11 to 35 cfh (cubic feet per hour).

Figures listed are a guide and are a composite of recommendations from American Welding Society (AWS) and electrode manufacturers.

17-2. Preparing Tungsten Electrode For Welding With Phase Control Machines

   Grinding the tungsten electrode produces dust and flying sparks which can cause injury and start fires. Use local exhaust (forced ventilation) at the grinder or wear an approved respirator. Read MSDS for safety information. Consider using tungsten containing ceria, lanthana, or yttria instead of thoria. Grinding dust from thoriated electrodes contains low-level radioactive material. Properly dispose of grinder dust in an environmentally safe way. Wear proper face, hand, and body protection. Keep flammables away.

A. Preparing Tungsten For DC Electrode Negative (DCEN) Welding

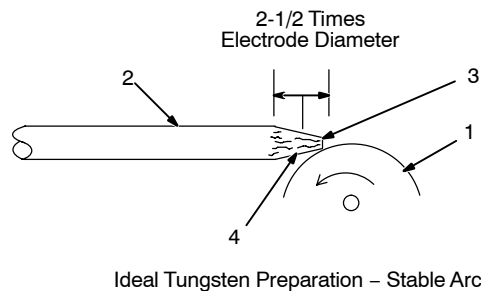
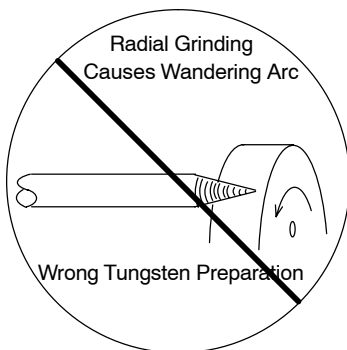

1 Grinding Wheel

Grind end of tungsten on fine grit, hard abrasive wheel before welding. Do not use wheel for other jobs or tungsten can become contaminated causing lower weld quality.

2 Tungsten Electrode

A 2% ceriated tungsten is recommended.

3 Flat

Diameter of this flat determines amperage capacity.

4 Straight Ground

Grind lengthwise, **not radial**.

B. Preparing Tungsten For AC Welding

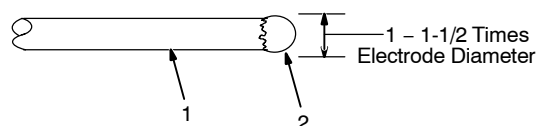

1 Tungsten Electrode

A pure tungsten is recommended..

2 Balled End

Ball end of tungsten by applying AC amperage recommended for a given electrode diameter (see Section 17-1). Let ball on end of the tungsten take its own shape.

SECTION 18 – GUIDELINES FOR TIG WELDING (GTAW)

gtaw 7/2006

18-1. Positioning The Torch

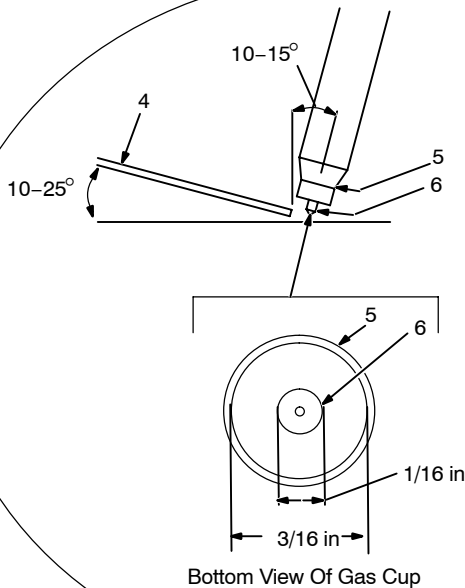
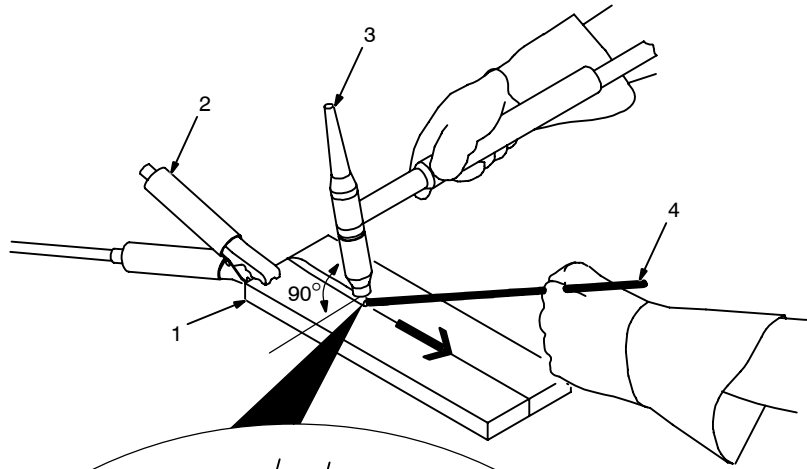

⚠ Grinding the tungsten electrode produces dust and flying sparks which can cause injury and start fires. Use local exhaust (forced ventilation) at the grinder or wear an approved respirator. Read MSDS for safety information. Consider using cerium or lanthanum based tungsten instead of thoriated. Thorium dust contains low-level radioactive material. Properly dispose of grinder dust in an environmentally safe way. Wear proper face, hand, and body protection. Keep flammables away.

1 Workpiece

Make sure workpiece is clean before welding.

2 Work Clamp

Place as close to the weld as possible.

3 Torch

4 Filler Rod (If Applicable)

5 Gas Cup

6 Tungsten Electrode

Select and prepare tungsten according to Section 17.

Guidelines:

The inside diameter of the gas cup should be at least three times the tungsten diameter to provide adequate shielding gas coverage. (For example, if tungsten is 1/16 in diameter, gas cup should be a minimum of 3/16 in diameter.)

Tungsten extension is the distance the tungsten extends out gas cup of torch.

The tungsten extension should be no greater than the inside diameter of the gas cup.

Arc length is the distance from the tungsten to the workpiece.

Ref. ST-161 892

18-2. Torch Movement During Welding

Tungsten Without Filler Rod

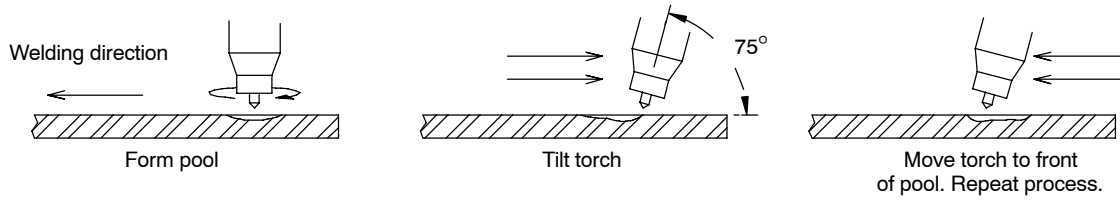

Tungsten With Filler Rod

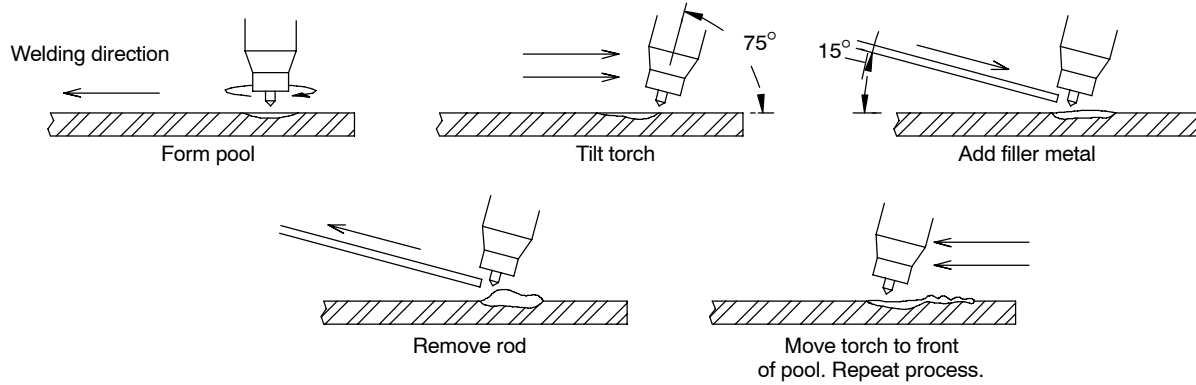

ST-162 002-B

18-3. Positioning Torch Tungsten For Various Weld Joints

Butt Weld And Stringer Bead

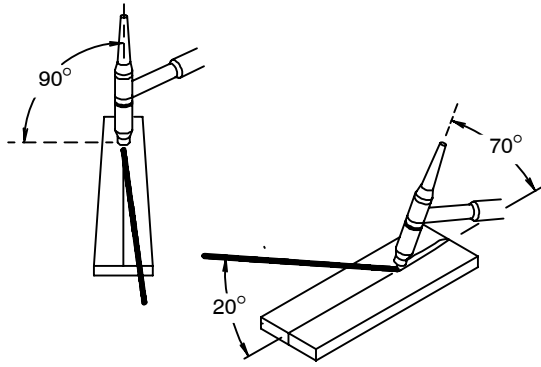

"T" Joint

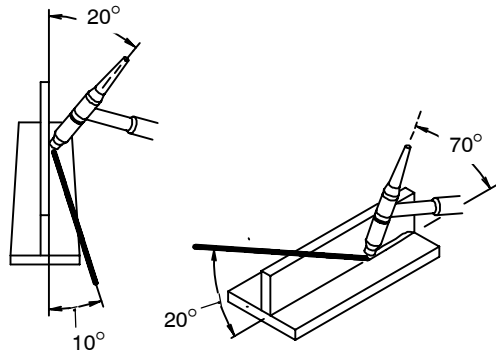
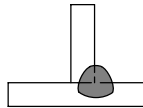

Lap Joint

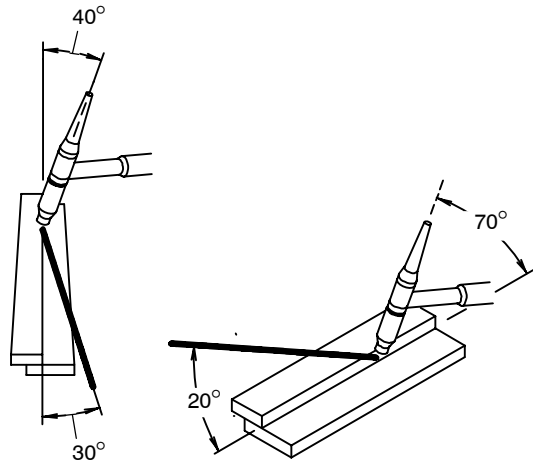
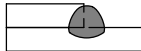

Corner Joint

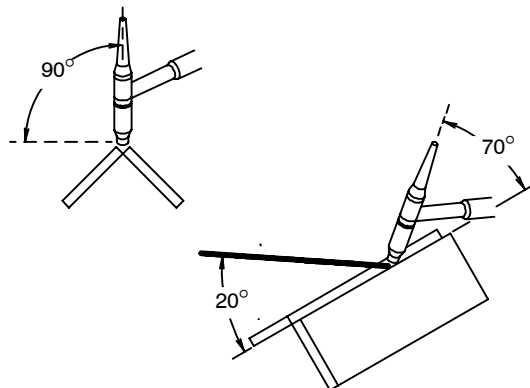
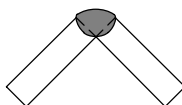

SECTION 19 – PARTS LIST

 Hardware is common and not available unless listed.

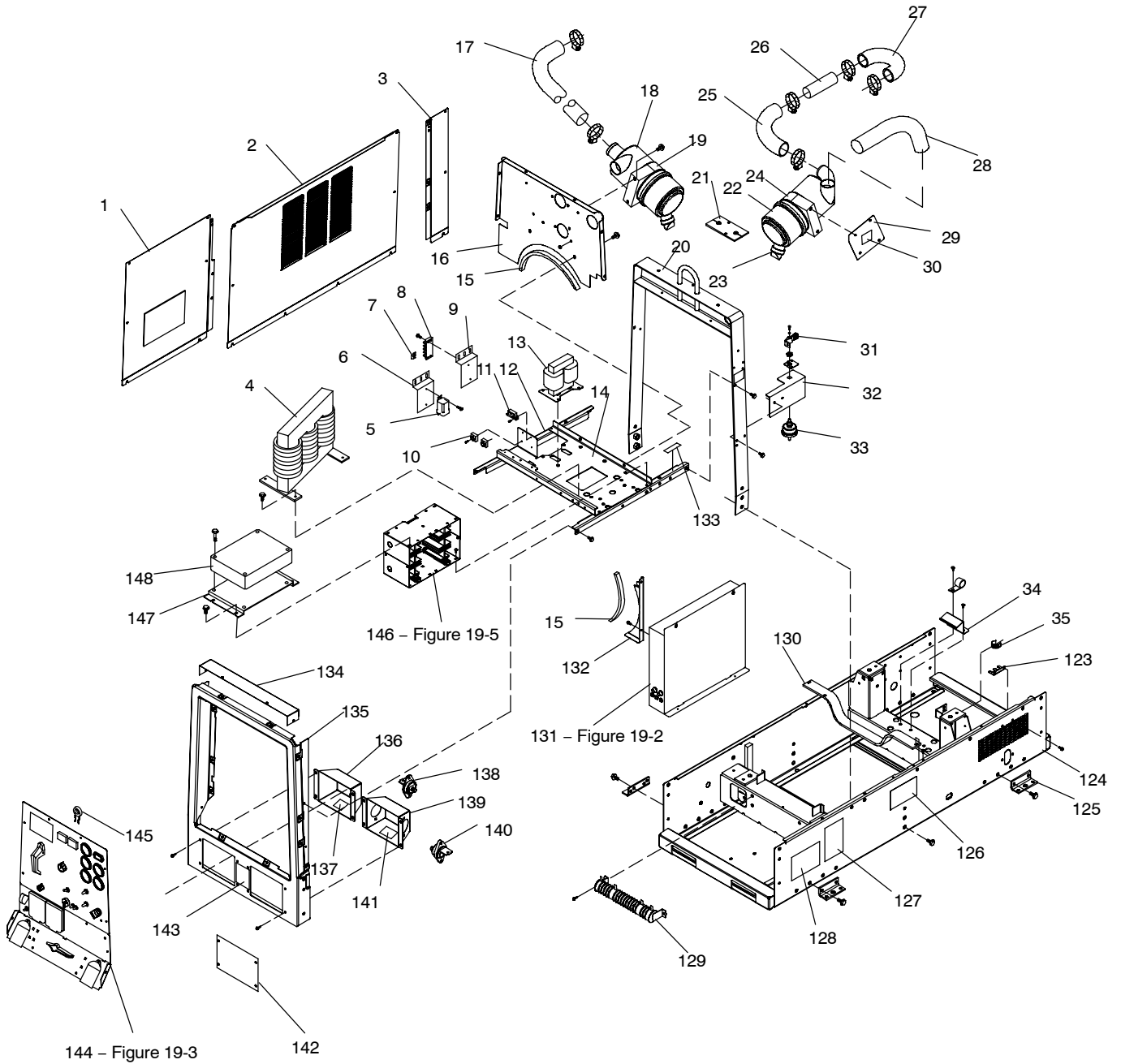
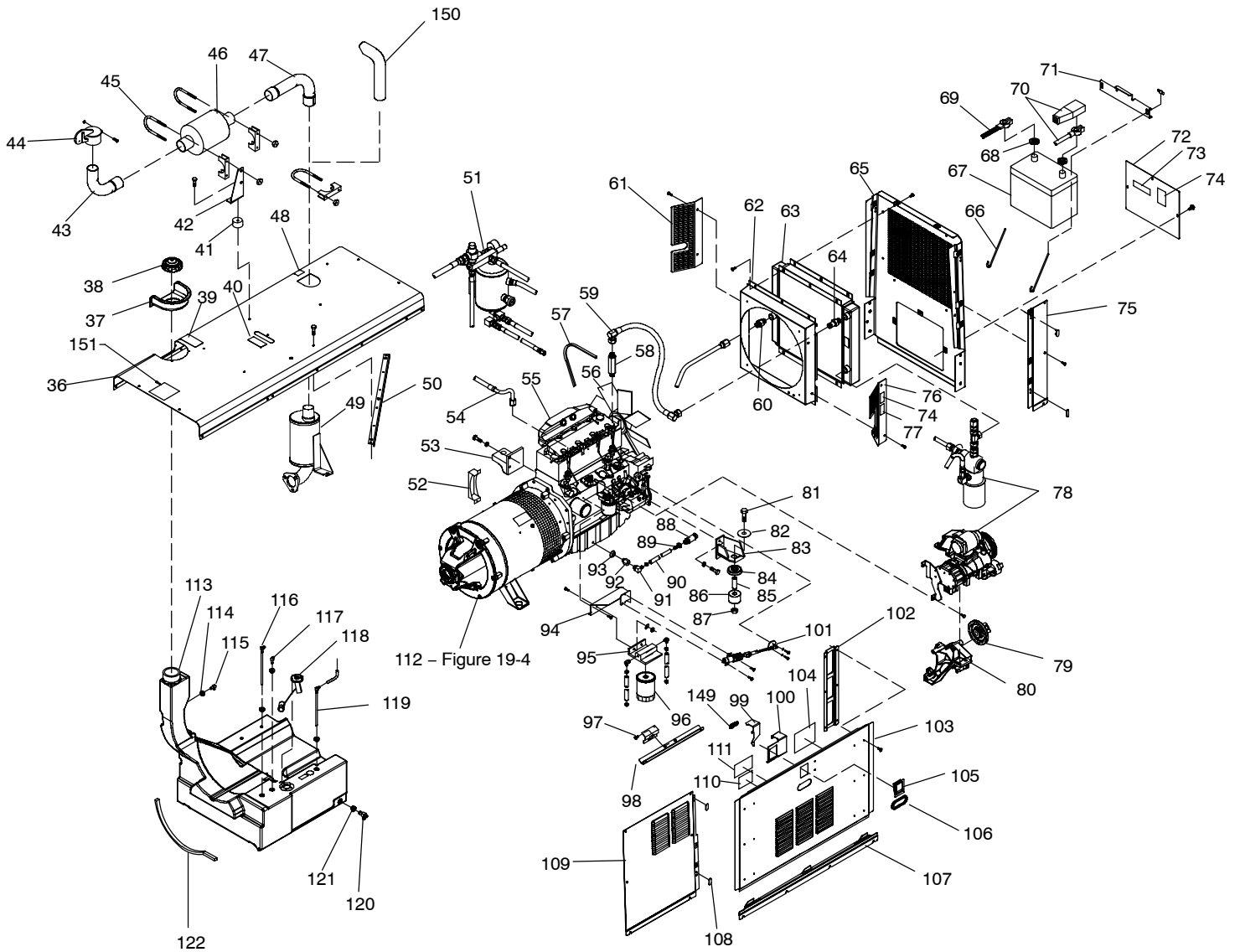

Figure 19-1. Main Assembly



Item No.	Dia. Mkgs.	Part No.	Description	Quantity
Figure 19-1. Main Assembly				
1		189824	Panel, Gen LH	1
2		189828	Panel, Engine Side	1
3		206601	Panel, Engine Extension LH	1
4	Z1	208277	Reactor, AC Environmental Rda	1
5	CR7	◆188636	Relay, OCV Control (Battery Charging)	1
6		◆081499	Bracket, Mtg Strip Terminal (Battery Charging)	1
7		038620	Link, Jumper Term Blk 30 Amp	1
	1T	189549	Block, Term Assy Standard W/Clamp (includes)	1
8		038621	Block, Term 30 Amp 4 Pole Frict Term Str Both Side	1
9		081499	Bracket, Mtg Strip Terminal	1
		138027	Edge Trim, Style TI750-b2x1/16 Black W/Clips 3.750	2
		020225	Clamp, Nyl .875 Clamp Dia X.500 Wide .203 Mtg Hole	1
10	SR4, SR5	035704	Rectifier, Integ Bridge 40 Amp 800 V	2
11	CB4	045061	Circuit Breaker, Auto Reset 24vdc 7 Amp	1
12		206352	Brace, Front To Center Upright	2
13	T1	205636	Transformer, W/Brkt Environmental	1
14		201697	Pan, Reactor And Rectifier	1
15		173352	Extrusion, Rubber (order by ft.)	1
16		189708	Firewall, Top	1
17		194485	Hose, Air Cleaner	1
18		189764	Air Cleaner, Intake (Engine) (includes)	1
		*192938	Filter, Air Element Primary	1
		*192939	Filter, Air Element Safety	1
		206556	Pipe, Air Cleaner Intake Deutz (Turbo Hose To Air Cleaner Hose)	1
19		189763	Bracket, Mtg Air Cleaner	1
20		206351	Upright, Center Assy	1
21		189464	Seal, Weather Lift Eye	1
22		197613	Air Cleaner, Intake 5.250 In (Compressor) (includes)	1
23		197675	Dust Ejector, Air Cleaner	1
		*197676	Element, Air Cleaner	1
		197677	Cover Assy, Air Cleaner	1
		197678	Body, Air Cleaner	1
		*197679	Element, Air Cleaner Safety	1
24		197829	Bracket, Mtg Air Cleaner	1
25		206696	Hose, Elbow Air Cleaner/Compressor	1
26		198457	Tube, Air Intake Perkins 104	1
27		206697	Hose, Elbow Air Cleaner/Compressor 180 Degree	1
28		207268	Hose, Cwc Flexaust 2.000 Id X 22.000	1
29		+219140	Bracket, Mtg Air Cleaner	1
30		210151	Label, Air Cleaner Location	1
31		◆209612	Lever, Switch Lockout Disconnect Battery	1
32		◆209597	Bracket, Mtg Battery Disconnect Switch	1
33		◆209611	Switch, Disc Battery 2P 6-36 Volts	1
34		196220	Bracket, Holddown Fuel Tank Rear	1
35		192362	Bracket, Mtg Nyl 1/2 Conduit	1
36		+206603	Cover, Top	1
37		189052	Grommet, Plastic Neck Filler Fuel	1
38		190198	Cap, Tank Screw-on 3.500 In W/Vent W/Lanyard 8"	1
39		192041	Label, Use Diesel Fuel Only	1
40		222513	Label, Warning Falling Equipment Can Cause Serious	1
41		◆143915	Mount, Sgl Stud 1.5 Dia X 1.000 Lg .312-18 Stud	1
42		◆205702	Bracket, Mtg Spark Arrestor	1
43		◆205749	Pipe, Exhaust Elbow	1
44		◆603767	Cap, Weather Exhaust No. 3	1
45		◆010875	Clamp, Muffler 2.000 Dia U Pld	3
46		◆205712	Spark Arrestor	1
47		◆205748	Pipe, Exhaust Elbow	1

Item No.	Dia. Mkgs.	Part No.	Description	Quantity
Figure 19-1. Main Assembly (Continued)				
48		224265	Label, Warning Hot Exhaust Parts Do Not Touch	1
49		213895	Manifold, Exhaust Muffler Bf4m2011 Deutz	1
50		202633	Support, Cover E-coat	1
51	Figure 19-6		Air Compressor Assembly	1
52		191577	Guard, Starter Deutz	1
53		191809	Bracket, Mtg Engine LH	1
54		209632	Hose, Tubing Oil Assyw/Fittings 22.380lg	1
55		218619	Engine, Deutz Dsl Elec Bf4m2011 (includes)	1
		193256	Adapter, Engine Deutz 1011	1
		195748	Flywheel, Deutz	1
		195746	Sender, Coolant Temp & 130c Switch	1
		195745	Switch, Pressure Oil 1.5 Bar Nc Cont	1
		*067265	Oil Filter	1
		*066217	Secondary Fuel Filter	1
		208041	Spacer, Stl .323 Id X .625 Od X .141 Thk (Alternator)	1
		193230	Sender, Pressure Oil 0- 100 Psi	1
		194403	Adaptor, Oil Pressure Sender	1
	GLOW PLUG	190059	Glow Plug	1
56		207203	Fan, Engine Cooling 18.000 Suction	1
		208042	Spacer, Stl .800id X 1.188od X .090 Thk (Fan Hub Bolt)	1
57		*207808	Belt, V .375 X 45.125 Lg	1
58		209675	Extension, Hydraulic 37 Deg Flare	1
59		209633	Hose, Tubing Oil Assyw/Fittings 27.040lg	1
60		209621	Ftg, Stl Adapter 3/4 Sae-3/4 Jic	1
61		207269	Guard, Fan LH	1
62		206749	Shroud, Fan Air Pak	1
63		206558	Cooler, Oil Engine/Compressor	1
64		209623	Ftg, Brs Adapter Long 3/4 Sae-3/4 Jic	1
65		201749	Upright, Rear Radiator	1
66		201006	Bolt, J Stl .312-18 X 7.750 Pld	2
67	BATT	190897	Battery, Stor 12v 650 Crk 110 Rsv Gp 24 Maint Free	1
68		108081	Terminal Protector, Battery Post Mtg	2
69		190206	Cable, Bat Neg 42 In Lg 2 Awg W/Clamp & .375 Rng	1
70		190207	Cable, Bat Pos 45 In Lg No 1 Awg W/Clamp & .406 Rng	1
71		203430	Bracket, Battery Holddown	1
72		+201183	Cover, Battery Access	1
73		168385	Label, Warning Battery Explosion Can Blind	1
74		225120	Label, Warning Moving Parts Can Cause Injury	7
75		+206602	Panel, Engine Extension R.H.	1
76		207270	Guard, Fan RH	1
77		210229	Label, Compressor Oil Fill	1
78	Figure 19-6		Air Compressor Assembly	1
79		208024	Pulley, Fan Assy W/Bearings	1
80		206613	Bracket, Mtg Fan/Alternator	1
81		199849	Screw, 625-11x4.00 Hex Hd-pln Gr5 Pld	4
82		071731	Washer, Flat .656idx2.250odx.187t Stl Pld	4
83		191812	Bracket, Mtg Engine R.h.	1
84		071890	Retainer, Mount Eng/Gen	4
85		071730	Tubing, Stl .875 Od X12ga Wall X 2.500	4
86		083476	Mount, Eng/Gen Nprn .875id X 2.500od X 2.000 60 Dur	4
87		135205	Nut, 625-11 .94hex .77h Stl Pld Elastic Stop Nut	4

Item No.	Dia. Mkgs.	Part No.	Description	Quantity
Figure 19-1. Main Assembly (Continued)				
		199505	Hose Assy, Oil Drain 32.000 Lg (includes)	1
88		165271	Valve, Oil Drain 3/8-18 Nptf	1
89		176529	Ftg, Hose Brs Barbed Fem 1/2 Tbg X 3/8 Npt	1
90		113854	Hose, Sae .500 Id X .780 Od Xcoil	2.666
91		176528	Ftg, Hose Brs Barbed Elbow M 1/2 Tbg X 1/2 Npt	1
92		173336	Ftg, Adapter Oil Drain	1
93		066298	Ring (Oil Drain)	1
94		218003	Bracket, Mtg Fuel Filter/Solenoid	1
95		232968	Base, Fuel Filter Assy	1
96		*192744	Filter, Fuel Spin-on	1
		199383	Hose, Sae .312 Id X .560 Od X 8.000 (Fuel Filter To Fuel Pump)	1
		191819	Hose, Sae .312 Id X .560 Od X 14.000 (Fuel Tank To Fuel Filter)	1
97		190992	Keeper, Latch Engine Access Door	1
98		206604	Channel, Stiffener Engine Access	1
99		209093	Bracket, Safety Latch	1
100		209092	Bracket, Mtg Saftey Latch	1
101		174064	Idle, Solenoid Assy (includes)	1
		196036	Bracket, Arm Throttle	1
		125663	Ball Joint, .250-28 Type Sp Lh	1
		175936	Rod, Throttle 5.250	1
		127994	Ball Joint, .250-28 Type Spf Female Rod End	1
		127648	Clevis, Throttle	1
		124974	Solenoid, 12vdc Pull/Hold Type 1" Stroke	1
		601868	Nut, 250-28 .44hex .26h Stl Pld	2
		126388	Nut, 250-28 .44hex .27h Stl Pld Lh	1
		089800	Nut, 250-20 .44hex .22h Stl Pld .58d Flange Deform	1
		108941	Screw, 250-20x1.00 Hexwhd.61d Gr5 Pld	1
		156733	Nut, 250-28 .44hex .13h Stl Pld Sem Cone Wshr.51d	1
102		209090	Bracket, Stiffener Panel	2
103		+209089	Panel, Engine Access Lift Off	1
104		206464	Label, Maintenance Big Blue Air Pak Deutz Ce	1
105		199592	Latch, Paddle Series 20 (Black)	1
106		210681	Handle, Pocket Pull Door Access	1
107		209091	Panel, Rocker Short	1
108		191626	Bumper, Door Engine Access	4
109		+189827	Panel, Gen Rh	1
110		207448	Label, Maintenance I R Compressor	1
111		209059	Label, Schematic Air System	1
112		Figure 19-4	Generator Assembly	1
113		218087	Tank, Fuel (includes)	1
114		124253	Bushing, Tank Fuel	4
115		189912	Ftg, Stl Barbed Elbow W/.047in Orifice Zinc Pld	1
116		189909	Ftg, Stand Pipe Hose .250 X 9.265lg 90 Deg Zinc	1
117		189913	Ftg, Stl Barbed Elbow Zinc Pld	1
118		190142	Sender, Fuel Gauge 9.750 Deep Tank	1
119		189910	Ftg, Stand Pipe Hose .3125 X 9.260lg 90 Deg Zinc	1
120		189908	Valve, Drain Fuel 180 Deg Zinc Pld	1
121		181572	Bushing, Tank Fuel	1
		196219	Hose, Sae .250 Id X .500 Od X 26.000 (Fuel Return Line)	1
122		191446	Extrusion, Rubber w/Adhesive 1.000 x 1.000 (order by ft.)	6ft
123		209094	Bracket, Mtg Hose	1
124		+212224	Base	1
125		191897	Bracket, Mtg Unit	4
126		224266	Label, Do Not Weld On Base	2
127		206463	Label, Manufacturing Rating	1
128		233953	Label, Warning General Precautionary CSA	2

Item No.	Dia. Mkgs.	Part No.	Description	Quantity
Figure 19-1. Main Assembly				
.. 129 R3 189699	.. Resistor, WW Tap 375 W 10 Ohm W/Mtg Bkt	1
.. 130	 218086	.. Bracket, Holddown Fuel Tank	1
.. 131		Figure 19-2	.. Control Box	1
.. 132	 189731	.. Firewall, Bottom	1
.. 133	 203260	.. Label, Caution Do Not Use Ether	1
.. 134	 191448	.. Cover, Top Front Upright	1
.. 135	 206609	.. Upright, Front	1
.. 136		+206606	.. Box, Valve Ball	1
.. 137	 209682	.. Label, Air Power Ingersoll-Rand	1
.. 138		◆039047	.. Terminal, Pwr Output Red	1
.. 139		+◆207095	.. Box, Battery Charge	1
.. 140		◆039046	.. Terminal, Pwr Output Black	1
.. 141		◆210156	.. Label, Battery Charge (Battery Charge +/-)	1
.. 142	 207096	.. Cover, Box Front Upright	1
.. 143	 209683	.. Label, Warning Safety Air System	1
.. 144		Figure 19-3	.. Panel, Front w/components	1
.. 145	... CT1 202130	.. Xfmr, Current Sensing (Auto Idle)	1
.. 146		Figure 19-5	.. Main Rectifier Assembly	1
.. 147	 193453	.. Bracket, Mtg Box Fcr	1
.. 148	... PC1 207397	.. Module, Field Current Regulator	1
.. 149	 085963	.. Spring, Ext .375 Od X .041 Wire X 2.000 (ForSafety Latch)	1
.. 150	 105734	.. Pipe, Muffler Extension Elbow 1.750 OD	1
.. 151	 233088	.. Label, Danger Using A Generator Indoors Can Kill You In Minutes	1
	 049525	.. Nut, 312-18 U-nut Multi-thread	4
	 049525	.. Nut, 312-18 U-nut Multi-thread	4
	 206468	.. Kit, Label (Includes Safety And Informational Labels)	1
		◆195118	.. Kit, Lock-Out Vandalism (includes)	1
		◆209238	.. Door, Access Rh W/Om Pocket	1
		◆209240	.. Door, Access Lh	1
		◆209236	.. Tab, Lockout	1
		◆209241	.. Mount, Access Rh	1
		◆209242	.. Mount, Access Lh	1
		◆189975	.. Hinge, Door Access 180 Deg.	4
		◆155146	.. Sponge, Nprn .060 X 1.000 Wide X 4.000 Sce 41 Close	3

+ When ordering a component originally displaying a precautionary label, the label should also be ordered.

* Recommended Spare Parts.

◆Optional

To maintain the factory original performance of your equipment, use only Manufacturer's Suggested Replacement Parts. Model and serial number required when ordering parts from your local distributor.

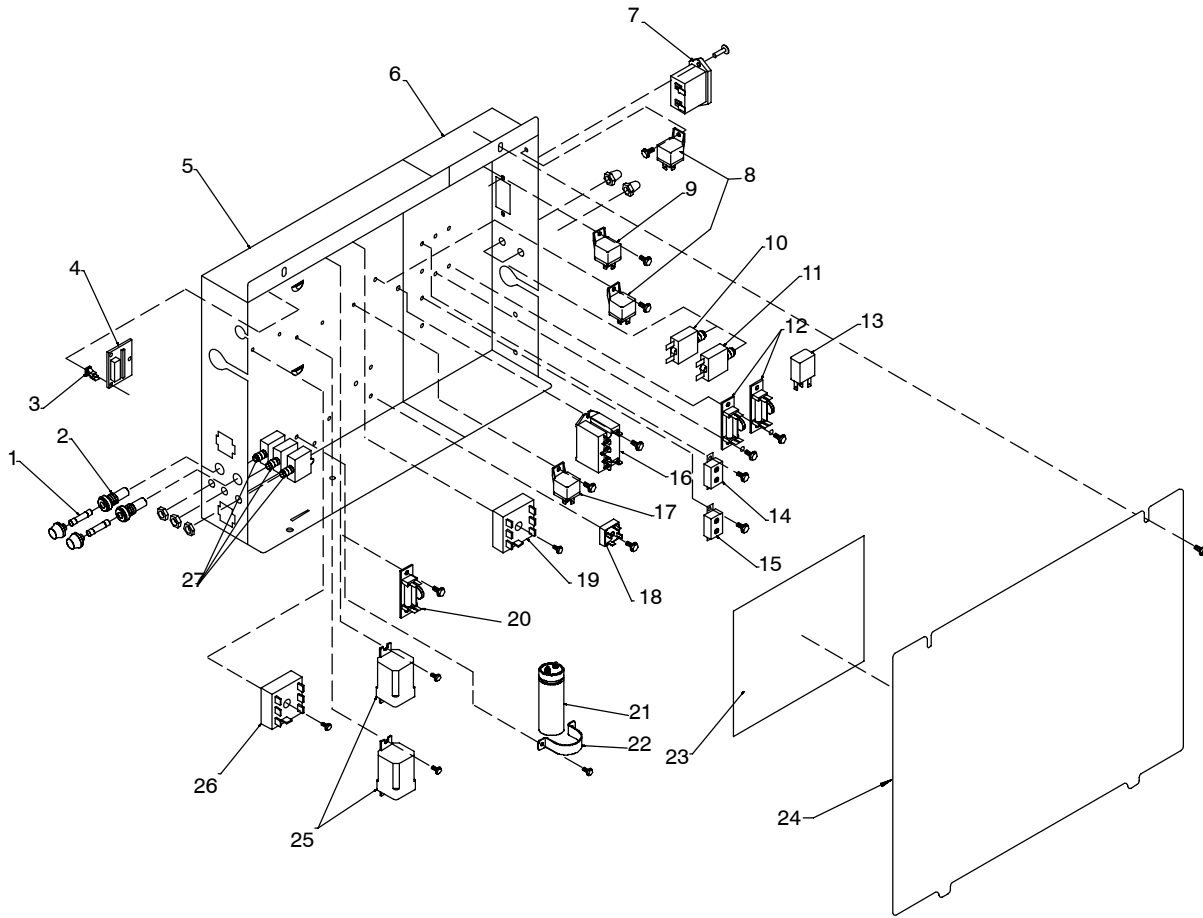

803 325-D

Figure 19-2. Control Box Assembly

Item No.	Dia. Mkgs.	Part No.	Description	Quantity
----------	------------	----------	-------------	----------

Figure 19-2. Control Box Assembly – (Figure 19-1 Item 131)

...	1	...	F1, F2	...	085874	..	Fuse, Mintr Cer Slo-blo 10. Amp 250 Volt	...	2
...	2	046432	..	Holder, Fuse Mintr .250 X 1.250 Panel Mtg	...	2
...	3	134201	..	Stand-off Support, Pc Card .312/.375w/Post&lock .43	...	3
...	4	...	PC9	...	192224	..	Circuit Card Assy, Display	...	1
...	5	201077	..	Control Box, LH	...	1
...	6	201078	..	Control Box, Rh	...	1
...	7	...	HM2	...	◆145247	..	Meter, Hour Air Compressor	...	1
...	8	..	CR3,CR6	..	090104	..	Relay, Encl 12vdc Spst 30a/15vdc 5pin Flange Mtg	...	2
...	9	...	CR8	...	197325	..	Relay, Encl 12vdc Spst 70a 4pin Flange Mtg	...	1
...	10	...	CB15	...	083432	..	Supplementary Protector, Man Reset 1p 10a 250vac Frict	...	1
...	11	...	CB8	..	◆139266	..	Supplementary Protector, Man Reset 1p 15a 250vac Frict (Air Dryer)	...	1
...	12	...	C8/D8,C10/D10	...	189701	..	Diode/Capacitor Board	...	2
...	13	...	CR1	...	214876	..	Relay, Encl 6vdc Spst 35a/14vdc 5 Pin	...	1
...	14	...	CB14	...	205927	..	Circuit Breaker, Auto Reset 12vdc 12 Amp	...	1
...	15	...	CB10	...	190374	..	Circuit Breaker, Auto Reset 12vdc 40 Amp	...	1
...	16	...	CR5	...	223710	..	Relay, Encl12vdc Dpst-no 25a 6pin Flange	...	1
...	17	...	CR14	..	◆090104	..	Relay, Encl 12vdc Spst 30a/15vdc 5pin Flange Mtg (Air Dryer)	...	1
...	18	...	SR1	...	035704	..	Rectifier, Integ Bridge 40. Amp 800v	...	1
...	19	...	PC7	...	195706	..	Module, Pull To Idle, Two Output, 7 Pin	...	1
...	20	...	C1/D1	...	189701	..	Diode/Capacitor Board	...	1
...	21	...	C9	...	087110	..	Capacitor, Elctlt 240 Uf 200 Vdc Can 1.39 Di	...	1
...	22	177136	..	Clamp, Capacitor 1.375 Dia	...	1

Item No.	Dia. Mkgs.	Part No.	Description	Quantity
Figure 19-2. Control Box Assembly (Continued)				
... 23		217823	Label, Layout Control Box	1
... 24		201079	Cover, Control Box	1
... 25	CR4, CR10	113247	Relay, Encl 12vdc Dpdt 20a/120vac 8pin Flange Mtg	2
... 26	TD1	214928	Timer, Delay On Make/Break Open 30 Sec 12vdc	1
... 27	CB11, CB12, CB13	139266	Supplementary Protector, Man Reset 1p 15a 250vac Frict	3
		217815	Harness, Engine Deutz Bf4m2011 (includes)	1
		156734	Nut, 010-32 .31hex .13h Stl Pld Sem Cone Wshr.38d	4
		148850	Socket, Relay 5 Pin	5
	S2	021467	Switch, Tgl Spst 3a 250v Off-none-(On) Spd Term (Located On Front Panel, See Figure 19-3)	1
		211292	Conn, Body 5 Terminal (For Ignition Switch S1)	1
		211293	Conn, Pack Terminal Position Assurance(Lock)	1
		150316	Conn, Rect Univ 039 6p/S 3row Plug Cable Lkg	5
	S10	206624	Switch, Tgl Spst 6a 125vac (On)-on-(On) Spd Term (Located On Front Panel, See Figure 19-3)	1
		164617	Clip, Wiring Straight	2
		219873	Harness, Control Box, Weld Control LH (includes)	1
	RC3	158466	Conn, Rect Univ 084 12p/S 3row Rcpt Cable/Panel Lkg	1
	RC1	135133	Conn, Rect Univ 084 9p/S 3row Rcpt Cable/Panel Lkg	1
		204737	Cable Tie Mount, Winged Push	3
	CR15	◆172015	Time Delay Relay (Air Dryer)	1

◆Optional

*Recommended Spare Parts.

To maintain the factory original performance of your equipment, use only Manufacturer's Suggested Replacement Parts. Model and serial number required when ordering parts from your local distributor.

☞ Hardware is common and not available unless listed.

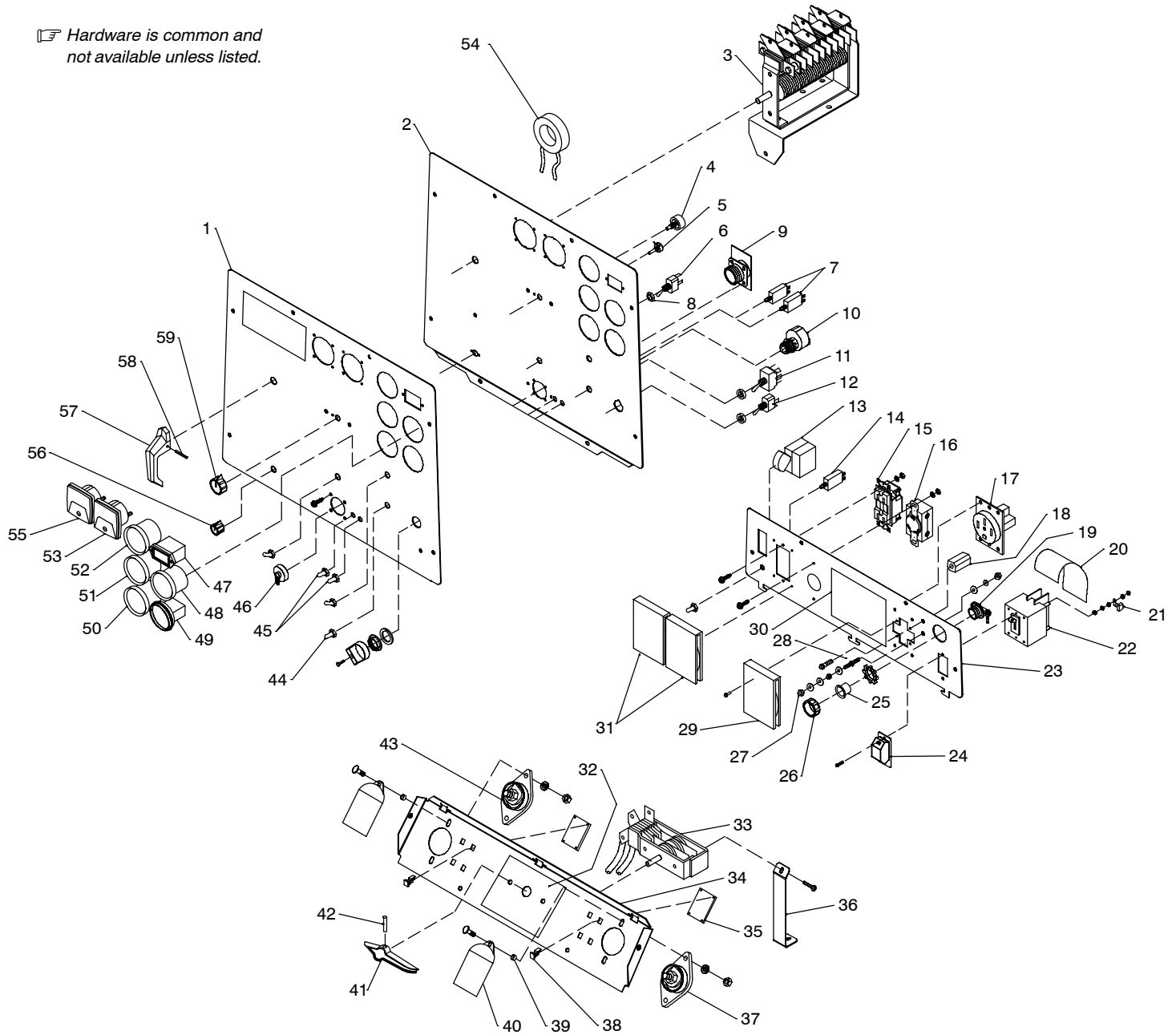

Figure 19-3. Panel, Front w/Components

803 326-A

Item No.	Dia. Mkgs.	Part No.	Description	Quantity
----------	------------	----------	-------------	----------

Figure 19-3. Panel, Front w/Components (Figure 19-1 Item 144)

...	1	217356	.. Plate, Screened Ident Control Rating	1
...	2	215014	.. Panel, Engine/Weld Control	1
...	3	S3 208278	.. Switch, Range/Changeover	1
...		192558	.. Harness, Range Switch (includes)	1
...		RC6 148389	.. Conn, Rect Univ 084 4p/S 1row Rcpt Cable/Panel Lkg	1
...	4	R1 193118	.. Pot, Cp Flat 1t 2. W 1k Ohm Linear	1

Item No.	Dia. Mkgs.	Part No.	Description	Quantity
Figure 19-3. Panel, Front w/Components (Continued)				
		206809	Harness, Weld Control (includes)	1
5	S6	193234	Switch, Rotary 6 Position Gold Contacts	1
		197257	Guard, Circuit Breaker (For S6 – Not Included w/Harness)	1
6	S5	011609	Switch, Tgl Spdt 15a 125vac On–none–on Spd Term Chr	1
	PLG9	193183	Conn, Rect Cinch 18 Pin	1
		196603	Seal, Switch 6 Position Rotary .250 Shaft	1
	PLG14	141450	Conn, Rect Metrmate 10skt 1row Plug Cable Lkg	1
		164617	Clip,Wiring Straight	2
	PLG10	150316	Conn, Rect Univ 039 6p/S 3row Plug Cable Lkg	1
7	CB5	139266	Supplementary Protector, Man Reset 1p 15a 250vac Frict	1
	CB6	139266	Supplementary Protector, Man Reset 1p 15a 250vac Frict	1
8		202209	Spacer, Nylon .221 Thk	2
9	PC6	192995	Circuit Card Assy, Connector/Receptacle	1
10	S1	212436	Switch, Ignition 4 Position W/Handle	1
11	S10	206624	Switch, Tgl Spdt 6a 125vac (On)–on–(On) Spd Term (Included In Engine Wiring Harness, See Figure Figure 19-2)	1
12	S2	021467	Switch,Tgl Spst 3a 250v Off–none–(On) Spd Term (Included In Engine Wiring Harness, See Figure Figure 19-2)	1
13	CB1	201083	Supplementary Protector, Man Reset 2p 20a 250vac	1
		201553	Clip, Retaining Circuit Breaker	1
		201109	Harness, Receptacle Auxillary Power (includes)	1
14	CB2	093996	Supplementary Protector, Man Reset 1p 20a 250vac Frict	1
15	GFCI1	151981	Rcpt, Str Dx Grd 2p3w 15/20a 125v *5–20r Gfi	1
16	RC1	147632	Rcpt,Tw Lk Grd 2p3w 30a 250v *L6–30r	1
		010146	Clamp, Nyl .625 Clamp Dia X.500 Wide .203 Mtg Hole	2
17	RC5	◆182954	Rcpt, Str 3p4w 50a 125/250v	1
18		◆025248	Stand-off, Insul .250-20 X 1.2	1
19		◆604102	Connector, Clamp Cable 1.000	1
20		◆197527	Guard, Circuit Breaker	1
21		◆197363	Terminal, Ring Tng Screw Clamp	3
22	CB7	◆214926	Supplementary Protector, Man Reset 3p 50a 250vac	1
23		+215347	Panel, Power	1
		+◆215363	Panel, Generator Power (Full KVA Option)	1
	CT2	◆197433	Transformer, Current Sensing	1
24		◆214927	Boot, Circuit Breaker 1 Pole	1
25		◆197508	Plug, Protective	1
26		◆077440	Bushing, Conduit 1 In	1
27		601836	Nut, 250–20 .50hex .19h Brs	3
		010915	Washer, Flat .257idx0.640odx.031t Brs	4
		163167	Washer, Lock .254idx0.489odx.062t Sst Split.250	2
28	GRD	083030	Stud, Brs .250–20 X 1.750 W/Hex Collar	1
29		◆209056	Cover, Receptacle W/Gasket	1
30		190861	Label, Warning Electric Shock And Moving Parts Etc	1
		◆197399	Label, Warning 3 Ph Generator Power	1
31		209056	Cover, Receptacle 2.250 Dia. Lexan	2
32		◆210149	Label, Battery Charge (Switch Position)	1
		◆	Label, Polarity/AC Switch Position	1
33	S12	◆220491	Switch, Polarity/AC	1
	S13	◆210217	Switch, Battery Charge Assy	1
34		201125	Panel, Mtg Terminal Power Output	1
35	PC4, PC5	189744	Circuit Card Assembly, HF	2
36		◆210206	Bracket, Support Switch	1
37		039046	Terminal, Pwr Output Black	1
		180735	Washer, Output Stud	2
38		134201	Stand–off Support, Pc Card .312/.375w/Post&lock .43	8
39		181169	Spacer, Output Stud	2
40		186621	Boot, Generic Output Stud	2

Item No.	Dia. Mkgs.	Part No.	Description	Quantity
Figure 19-3. Panel, Front w/Components (Continued)				
... 41		◆059773	Switch, Handle (Polarity/AC Switch)	1
... 42		◆010647	Pin (Polarity/AC Switch)	1
		◆059773	Handle, Switch (Battery Charging)	1
		◆010647	Pin, Spring Cs .156 X 1.250 (Battery Charging)	1
		◆081499	Bracket, Mtg Strip Terminal (Battery Charging)	1
... 43		039047	Terminal, Pwr Output Red	1
... 44		021385	Boot, Toggle Switch Lever	1
... 45		190323	Boot, Circuit Breaker Clear Hex Nut	4
... 46		170391	Conn, Circ Ms Protective Cap Size 20 Nylon	1
... 47	HM1	210424	Meter, Hour 12–24vdc (Snap-in)	1
... 48	FUEL	192265	Gauge, Fuel Elec Switch W/O Switchgage Sensor	1
... 49	BAT	193228	Meter, Volt DC 8 – 18 Scale 2.250 In Black Face	1
... 50	AIR	206599	Gauge, Pressure 0–200 Psi Electric Switch	1
... 51	TEMP	217084	Gauge, Engine Temperature	1
... 52	OIL	217083	Gauge, Engine Oil Pressure	1
... 53	A1	◆164873	Meter, Amp AC/DC 0– 500 0–600 Dc Scale 2.5 In	1
... 54	CT3	◆209274	Xfmr, Current (Meters)	1
... 55	V1	◆164874	Meter, Volt AC/DC 0– 100 Scale 2.5 In	1
... 56		097922	Knob, Pointer .875 Dia X .250 Id W/Set Screwsplstc	1
... 57		189161	Handle, Switch Range	1
... 58		010647	Pin, Spring Cs .156 X 1.250	1
... 59		097924	Knob, Pointer 1.625 Dia X .250 Id W/Set Screwsplstc	1
		072590	Lock, Shaft Pot .375–32 X .250 Dia Shaft Tall	1
		215207	Harness, Unit Weld Control – CV (includes)	1
	PLG6	114063	Conn, Rect Univ 084 4p/S 1row Plug Cable Lkg	1
	PLG8	193184	Conn, Rect Cinch 30 Pin	1
		147992	Conn, Rect Univ 039 10p/S 2row Plug Cable Lkg	1
	PLG13	158465	Conn, Rect Univ 084 12p/S 3row Plug Cable Lkg	1
		088731	Bushing, Snap-in Nyl .375 Id X .500 Mtg Hole	1
		135873	Clip, Conduit Convolutd 1/2 In 6.35mm Mtg Hole	3
		187654	Seal, Wire Univ 12p/S 3row	1
		196602	Plug, Cavity 18,30 Position Cinch Connector	7
		059712	Clip, Component .437 Dia Mtg Adh Back	1
		024103	Blank, Snap-in Nyl .750 Mtg Hole Black	1
		120304	Blank, Snap-in Nyl .250 Mtg Hole Black	2
		025234	Plug, Str Grd 2p3w 15a 250v *6–15p	1

◆Optional

+ When ordering a component originally displaying a precautionary label, the label should also be ordered.

To maintain the factory original performance of your equipment, use only Manufacturer's Suggested Replacement Parts. Model and serial number required when ordering parts from your local distributor.

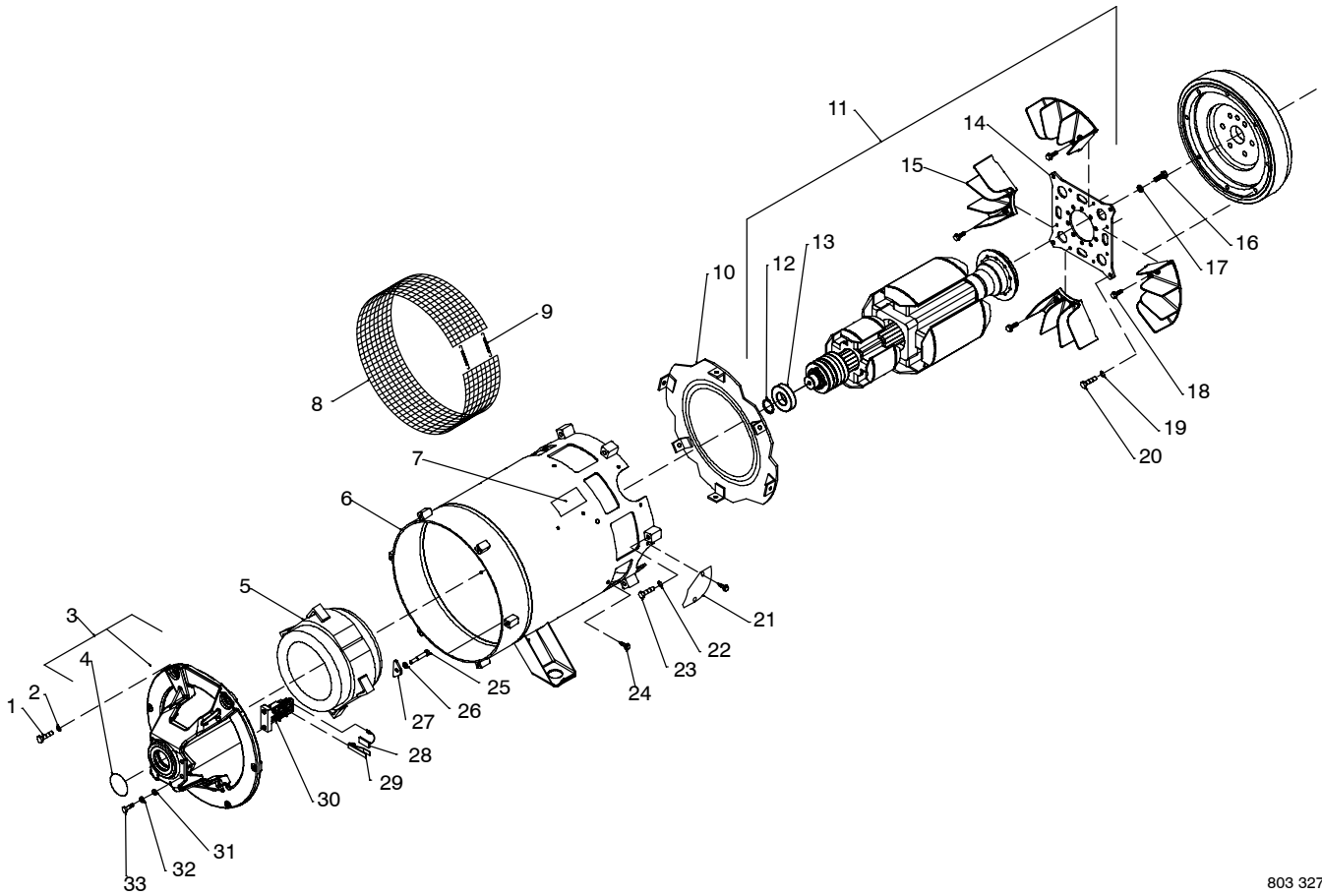

803 327

Figure 19-4. Generator

Item No.	Dia. Mkgs.	Part No.	Description	Quantity
----------	------------	----------	-------------	----------

Figure 19-4. Generator (Figure 19-1 Item 112)

...	1	132053	.. Screw, 375-16x1.50 Hex Hd-pln Gr5 Pld	6
...	2	183387	.. Washer, Cone .380idx .860odx.109t Stl Pld 4000lbs	6
...	3	195911	.. Endbell, Gen (includes)	1
...	4	143220	.. O-Ring 2.859 ID X .139 Cs 70 Duro Viton	1
...	5	AUX STATOR . 201099	.. Stator, Exciter/Aux Power	1
...	6	STATOR .. +208287	.. Stator, Weld Assy Complete	1
...	...	STATOR + ♦209220	.. Stator, Weld Assy Complete (3-Phase Generator Option)	1
...	7	225120	.. Label, Warning Moving Parts Can Cause Serious	1
...	8	190197	.. Guard, Generator Wire Mesh	1
...	9	172674	.. Spring, Ext .240 Od X .041 Wire X 3.500 Pld	2
...	10	039207	.. Baffle, Air Gen	1
...	11	ROTOR . 212997	.. Rotor, Generator (Includes)	1
...	12	024617	.. Ring, Rtnng Ext 1.375 Shaft X .050 Thk	1
...	13	053390	.. Bearing, Ball Rdl Sgl Row 1.370 X 2.830 X .6	1
...	...	210447	.. Fan, Rotor Assy Generator (Segmented) (includes)	1
... Hub, Drive (Not Sold Separately)	1
...	14	210332	.. Plate, Flex Hubmount	1
...	15	206242	.. Fan, Rotor Segmented Assy Gen	4
...	16	049026	.. Screw, M10-1.5x 25 Hex Hd-pln 8.8 Pln	10
...	17	083883	.. Washer, Lock .402idx0.709odx.087t Stl Split10mm	10
...	18	080389	.. Screw, 312-18x1.00 Hexwhd.66d Stl Pld Slffmg Tap-rw	8
...	19	083883	.. Washer, Lock .402idx0.709odx.087t Stl Split10mm	4
...	20	049026	.. Screw, M10-1.5x 25 Hex Hd-pln 8.8 Pln	4
...	21	191579	.. Cover, Starter Hole	1
...	22	083883	.. Washer, Lock .402idx0.709odx.087t Stl Split10mm	6

Item No.	Dia. Mkgs.	Part No.	Description	Quantity
----------	------------	----------	-------------	----------

Figure 19-4. Generator (Continued)

... 23	172555	.. Screw, M10-1.5x 50 Hex Hd-pln 8.8 Pld	6
... 24	602159	.. Screw, 312-18x .75 Hexwhd.66d Stl Pld Slffmg Tap-rw	6
... 25	604950	.. Screw, 312-18x2.00 Hex Hd-pln Gr5 Pld	4
... 26	602211	.. Washer, Lock .318idx0.586odx.078t Stl Pld Split.312	4
... 27	139341	.. Washer, Exciter	4
... 28	*190823	.. Brush, Contact Elect .250 X.500 X 1.250 Grd Ay	3
... 29	188560	.. Clip, Spring	3
... 30	189142	.. Brushholder Assy, Generator	1
... 31	602242	.. Washer, Flat .375idx0.875odx.083t Stl Pld	2
... 32	602211	.. Washer, Lock .318idx0.586odx.078t Stl Pld Split.312	2
... 33	604534	.. Screw, 312-18x1.25 Hex Hd-pln Gr5 Pld	2

+ When ordering a component originally displaying a precautionary label, the label should also be ordered.

*Recommended Spare Parts.

◆Optional

To maintain the factory original performance of your equipment, use only Manufacturer's Suggested Replacement Parts. Model and serial number required when ordering parts from your local distributor.

☞ Hardware is common and not available unless listed.

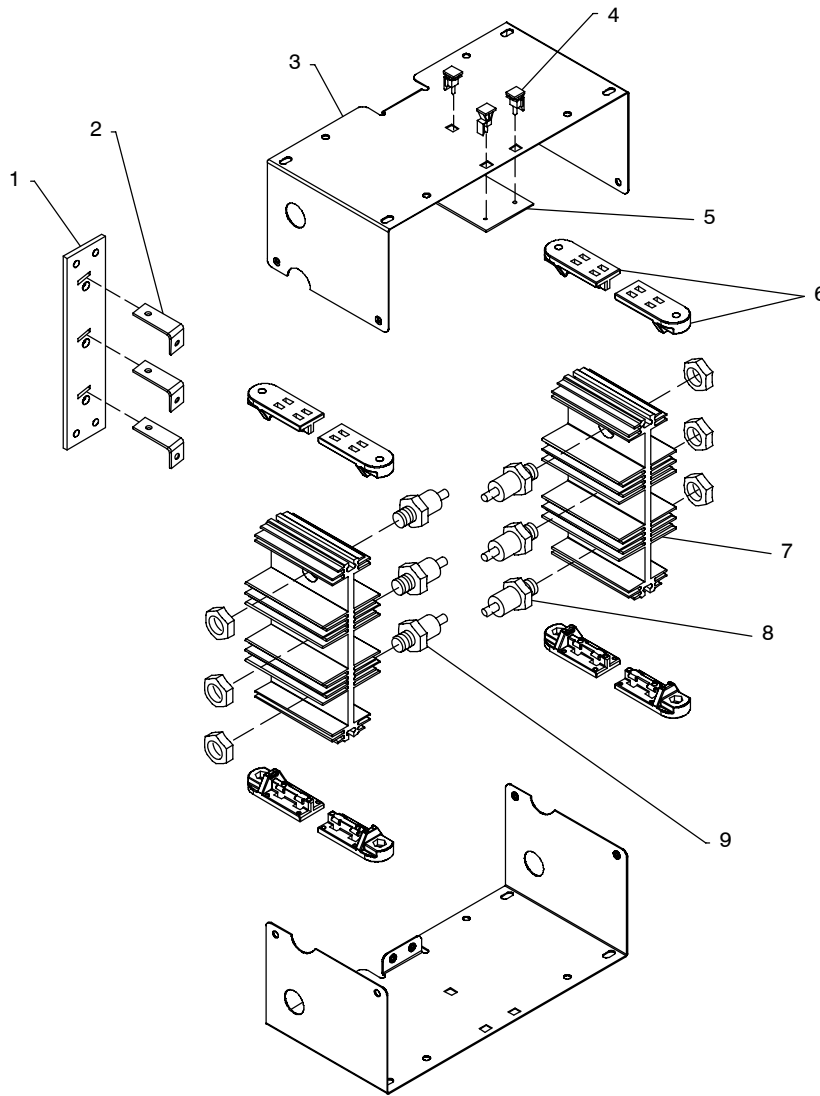

802 279-A

Figure 19-5. Main Rectifier Assembly

Item No.	Dia. Mkgs.	Part No.	Description	Quantity
----------	------------	----------	-------------	----------

Figure 19-5. Main Rectifier Assembly (Figure 19-1 Item 146)

.....	SR3 215910	.. Rectifier, environmental (includes) 1
... 1 188137 Connection Board, Rectifier Ac 1
... 2 188517 Bus Bar, Conn Bd 3
... 3 188135 Enclosure, Rectifier 2
... 4 134201 Stand-off Support, Pc Card .312/.375w/Post&lock .43 3
... 5	PC3 215755 Circuit Card Assy, Protection 1
... 6 188136 Insulator, Heatsink 8
... 7 188493 Heat Sink, Rectifier Al 2
... 8	D3, D5, D7 208334 Diode, Rect 275. A 300v Sp 3
... 9	D2, D4, D6 208335 Diode, Rect 275. A 300v Rp 3

To maintain the factory original performance of your equipment, use only Manufacturer's Suggested Replacement Parts. Model and serial number required when ordering parts from your local distributor.

 Hardware is common and not available unless listed.

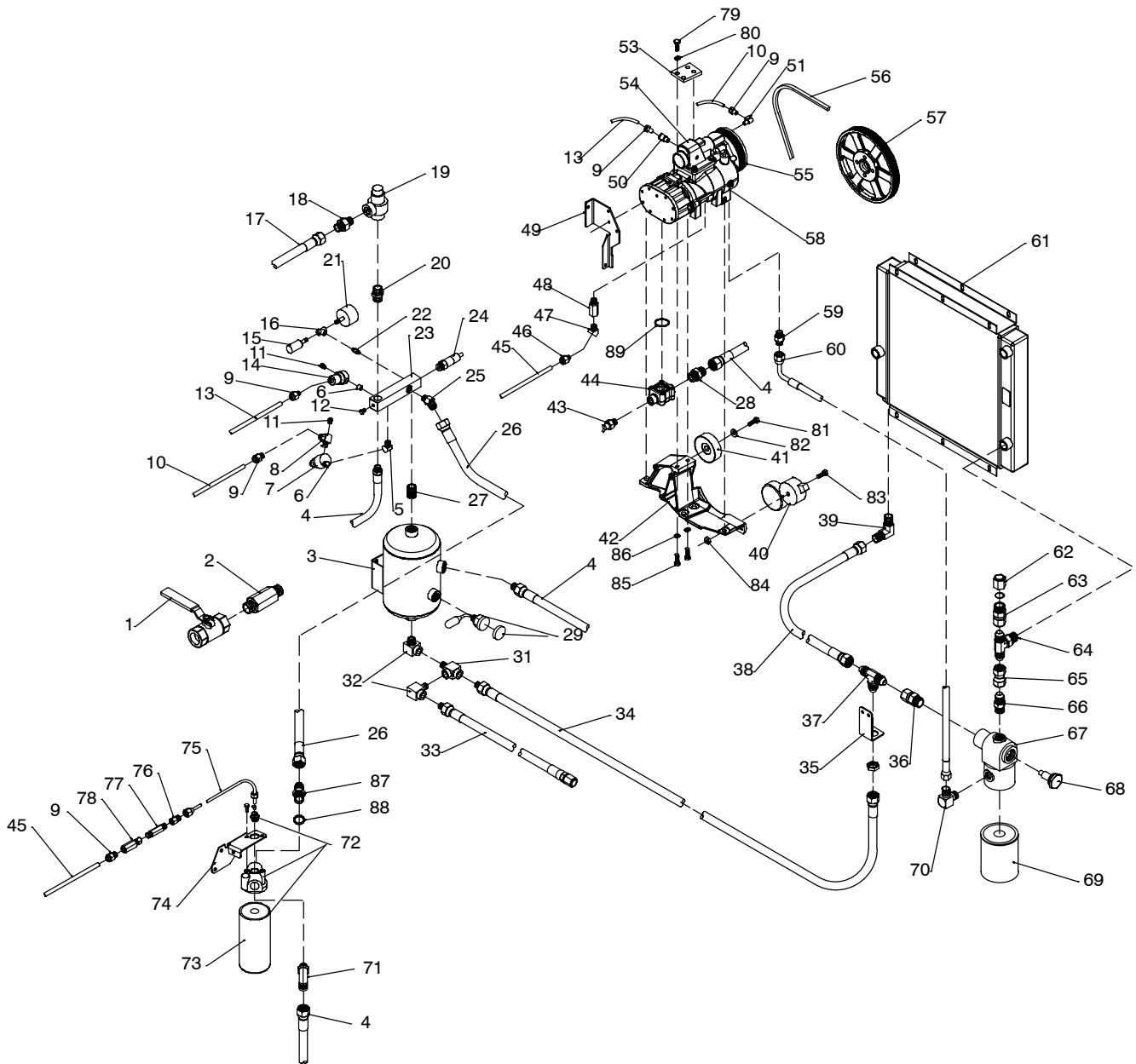

Figure 19-6. Air Compressor Assembly

Item No.	Dia. Mkgs.	Part No.	Description	Quantity
Figure 19-6. Air Compressor Assembly (Figure 19-1 Item 78)				
1		206607	Valve, Ball	1
2		210523	Ftg, Flrd Stl Tube End/Female Pipe End 3/4	1
3		206939	Tank, Oil Separator	1
4		210248	Hose Assy, Air W/Fittings 3/4 X 35.250 Lg	2
5		084999	Ftg, Pipe Brs Elbow St 45 1/4 Npt	1
6		117826	Ftg, Pipe Brs Nipple Close 1/4 Npt	2
7		210053	Valve, Pressure Regulator	1
8		071270	Ftg, Pipe Brs Tee St 1/4 Npt 071 269	1
9		209854	Ftg, Pipe Adapter M 1/4 Npt X 1/4 Line	4
10		218602	Hose, Nylon Blue 44.000lg	1
11		210040	Orifice/Muffler,120	2
12		151662	Ftg, Pipe Brs Plug Hex .125 Npt	1
13		218601	Hose, Nylon Red 36.000lg	1
14		210054	Valve, Automatic Blowdown	1
15		206746	Switch, Pressure 20psi Nc	1
16		602965	Ftg, Pipe Brs Tee 1/8 Npt	1
17		209635	Hose, Assy w/Fittings 42.360lg	1
18		209621	Ftg, Stl Adapter 3/4 Sae-3/4 Jic	1
19		210051	Valve, Check Minimum Pressure	1
20		209767	Ftg, Pipe Stl Connector M 3/4 Sae-npt Adapter	1
21		206615	Sender, Pressure Oil 0- 200 Psi	1
22		073655	Ftg, Pipe Brs Nipple Hex 1/8 Npt	1
23		206937	Manifold, Air	1
24		206743	Valve, Safety Relief 150psi	1
25		209754	Ftg, Pipe Stl Elbow M 45dg 3/4 X (Npt-jic 45dg)	1
26		214685	Hose Assy, Air W/Fittings 3/4 X 21.750 Lg	1
27		209787	Ftg, Pipe Stl Nipple Close 3/4 Npt	2
28		209621	Fitting, Stl Adapter 3/4 SAE - 3/4 JIC	1
29		210058	Gauge, Oil Level Assembly	1
30		Deleted		
31		209766	Ftg, Pipe Stl Tee Street 3/4 Npt M-f-f	1
32		209457	Ftg, Pipe Stl Elbow St 3/4 Npt	2
33		209638	Hose, Oil W/Fittings 25.670 Lg	1
34		209639	Hose, Oil W/Fittings 26.320 Lg	1
35		210254	Bracket, Mtg Tbg	1
36		210251	Ftg, Stl Swivel Straight Thread Conn 3/4 O-ring	1
37		210252	Ftg, Stl Bulkhead Branch Tee 3/4 Flare Tube End	1
38		210250	Hose Assy, Oil W/Fittings 3/4 X 15.500 Lg	1
39		209765	Ftg, Pipe Stl Elbow Adapter 90dg 3/4 Sae-jic-	1
40		208040	Tensioner,Belt w/Pully	1
41		208428	Idler Pulley	1
42		225038	Bracket, Mtg Compressor	1
43		206742	Switch, High Air Temperature 248f Nc	1
		210022	O-ring, High Air Temp Switch	1
44		211904	Manifold, Compressor	1
		218558	Screw, M 8-1.2x 50 Hex Hd-pln 8.8 Pld (Manifold Mtg.Screws)	4
45		209641	Hose, Nylon White 32.000lg	1
46		209855	Ftg, Pipe Stl Adapter M 1/8 Npt X 1/4 Line	2
47		015732	Ftg, Pipe Brs Elbow St 45 1/8 Npt	1
48		209852	Ftg, Pipe Stl Adapter M M10 X 1/8 Npt F	1
49		225005	Brace, Compressor	1
50		084999	Ftg, Pipe Brs Elbow St 45 1/4 NPT	1
51		176518	Ftg, Pipe Brs Elbow St 1/4 Npt	1
52		Deleted		

Item No.	Dia. Mkgs.	Part No.	Description	Quantity
Figure 19-5. Air Compressor Assembly (Continued)				
53		206698	Plate, Mtg Compressor To Bracket	1
54		218305	Valve, Inlet Unloader 90dg	1
		210016	Gasket, Unloader Valve	1
55	CLUTCH	210055	Clutch, Electro Magnetic 12vdc W/5.75 Dia Pulley	1
56		218609	Belt, Micro V 21mm X 1485mm	1
57		206800	Pulley, Crankshaft	1
58		210001	Airend, Gear-driven W/Tapered Input Shaft	1
59		209853	Ftg, Pipe Stl Adapter M M16 1.5 X 1/2 Jic	1
60		209634	Hose, Tubing Oil Assyw/Fittings 15.860lg	1
61		206558	Cooler, Oil Engine/Compressor	1
62		209851	Ftg, Pipe Stl Tube End Cap 3/4 Orfs	1
63		209825	Ftg, Stl Adapter Swivel 12m X Jic-12 F	1
64		209764	Ftg, Pipe Stl Tee Branch Sae-12 X Jic-12	1
65		209828	Ftg, Stl Swivel Union Jic-12 F-f	1
66		209621	Ftg, Stl Adapter 3/4 Sae-3/4 Jic	1
67		210052	Valve, Oil Temperature Control	1
68		206744	Thermostat, 170f (w/gasket)	1
69		206745	Filter, Oil	1
70		209756	Ftg, Pipe Stl Elbow M 90dg 1/2 Jic X 3/4 Sae	1
71		214686	Ftg, Pipe Stl Elbow 90dg 3/4bspt M X 3/4 Jic M	1
72		210023	Filter, Separator Assembly (includes)	1
73		206747	Separator, Oil/Air Filter	1
74		208029	Bracket, Mtg Filter Base	1
75		209646	Tubing, Ssstl .312 Od X.028 W/Ftgs	1
76		209856	Ftg, Stl Adapter Tube End Reducer 04f X 05m	1
77		210027	Valve, Check/Scavenge Orifice/Screen	1
78		209755	Ftg, Pipe Stl Swivel F 1/4 Npt X 1/4 F Jic	1
		*210056	Oil, Compressor 1gal	1
79		044772	Screw, M12-1.7x 30 Hex Hd-pln 8.8 Pln	6
80		602216	Washer, Lock .502idx0.879odx.151t Stl Pld Split.500	6
81		198447	Screw, M10-1.5x 20 Hex Hd-pln 8.8 Pln	1
82		602243	Washer, Flat .438idx1.000odx.083t Stl Pld	1
83		208425	Screw, M10-1.5x 60 Hex Hd-pln 8.8 Pld Din 931	1
84		198631	Nut, M10 Hex Lock Nut Stl Pld	1
85		208426	Screw, M12-1.75x 40 Hex Hd 12pt Flange Screw 12.9	2
86		602216	Washer, Lock .502idx0.879odx.151t Stl Pld Split.500	2
87		214687	Ftg, Pipe Stl 3/4bspp X 3/4 Jic M	1
88		214920	Seal, Ring Bonded Rbr/Stl .950 Id X 1.380 Od X .100	1
89		218423	O-Ring	1

To maintain the factory original performance of your equipment, use only Manufacturer's Suggested Replacement Parts. Model and serial number required when ordering parts from your local distributor.

TRUE BLUE[®]

WARRANTY

Effective January 1, 2007

(Equipment with a serial number preface of "LH" or newer)

This limited warranty supersedes all previous Miller warranties and is exclusive with no other guarantees or warranties expressed or implied.

Warranty Questions?

Call
1-800-4-A-MILLER
for your local
Miller distributor.

Your distributor also gives
you ...

Service

You always get the fast,
reliable response you
need. Most replacement
parts can be in your
hands in 24 hours.

Support

Need fast answers to the
tough welding questions?
Contact your distributor.
The expertise of the
distributor and Miller is
there to help you, every
step of the way.

LIMITED WARRANTY – Subject to the terms and conditions below, Miller Electric Mfg. Co., Appleton, Wisconsin, warrants to its original retail purchaser that new Miller equipment sold after the effective date of this limited warranty is free of defects in material and workmanship at the time it is shipped by Miller. THIS WARRANTY IS EXPRESSLY IN LIEU OF ALL OTHER WARRANTIES, EXPRESS OR IMPLIED, INCLUDING THE WARRANTIES OF MERCHANTABILITY AND FITNESS.

Within the warranty periods listed below, Miller will repair or replace any warranted parts or components that fail due to such defects in material or workmanship. Miller must be notified in writing within thirty (30) days of such defect or failure, at which time Miller will provide instructions on the warranty claim procedures to be followed.

Miller shall honor warranty claims on warranted equipment listed below in the event of such a failure within the warranty time periods. All warranty time periods start on the delivery date of the equipment to the original end-user purchaser, and not to exceed one year after the equipment is shipped to a North American distributor or eighteen months after the equipment is shipped to an International distributor.

- 5 Years Parts — 3 Years Labor
 - * Original main power rectifiers
- 3 Years — Parts and Labor
 - * Transformer/Rectifier Power Sources
 - * Plasma Arc Cutting Power Sources
 - * Process Controllers
 - * Semi-Automatic and Automatic Wire Feeders
 - * Inverter Power Sources (Unless Otherwise Stated)
 - * Water Coolant Systems (Integrated)
 - * Intellitig
 - * Engine Driven Welding Generators
(NOTE: Engines are warranted separately by the engine manufacturer.)
- 1 Year — Parts and Labor Unless Specified
 - * Motor Driven Guns (w/exception of Spoolmate Spoolguns)
 - * Positioners and Controllers
 - * Automatic Motion Devices
 - * RFCS Foot Controls
 - * Induction Heating Power Sources, Coolers, and Electronic Controls/Recorders
 - * Water Coolant Systems (Non-Integrated)
 - * Flowgauge and Flowmeter Regulators (No Labor)
 - * HF Units
 - * Grids
 - * Spot Welders
 - * Load Banks
 - * Arc Stud Power Sources & Arc Stud Guns
 - * Racks
 - * Running Gear/Trailers
 - * Plasma Cutting Torches (except APT & SAF Models)
 - * Field Options
(NOTE: Field options are covered under True Blue[®] for the remaining warranty period of the product they are installed in, or for a minimum of one year — whichever is greater.)
 - * Bernard-Branded Mig Guns (No Labor)
 - * Weldcraft-Branded TIG Torches (No Labor)
 - * Subarc Wire Drive Assemblies
- 6 Months — Batteries
- 90 Days — Parts
 - * MIG Guns/TIG Torches and Subarc (SAW) Guns

- * Induction Heating Coils and Blankets, Cables, and Non-Electronic Controls
- * APT & SAF Model Plasma Cutting Torches
- * Remote Controls
- * Accessory (Kits)
- * Replacement Parts (No labor)
- * Spoolmate Spoolguns
- * Canvas Covers

Miller's True Blue[®] Limited Warranty shall not apply to:

- Consumable components; such as contact tips, cutting nozzles, contactors, brushes, slip rings, relays or parts that fail due to normal wear. (Exception: brushes, slip rings, and relays are covered on Bobcat, Trailblazer, and Legend models.)**
- Items furnished by Miller, but manufactured by others, such as engines or trade accessories. These items are covered by the manufacturer's warranty, if any.
- Equipment that has been modified by any party other than Miller, or equipment that has been improperly installed, improperly operated or misused based upon industry standards, or equipment which has not had reasonable and necessary maintenance, or equipment which has been used for operation outside of the specifications for the equipment.

MILLER PRODUCTS ARE INTENDED FOR PURCHASE AND USE BY COMMERCIAL/INDUSTRIAL USERS AND PERSONS TRAINED AND EXPERIENCED IN THE USE AND MAINTENANCE OF WELDING EQUIPMENT.

In the event of a warranty claim covered by this warranty, the exclusive remedies shall be, at Miller's option: (1) repair; or (2) replacement; or, where authorized in writing by Miller in appropriate cases, (3) the reasonable cost of repair or replacement at an authorized Miller service station; or (4) payment of or credit for the purchase price (less reasonable depreciation based upon actual use) upon return of the goods at customer's risk and expense. Miller's option of repair or replacement will be F.O.B., Factory at Appleton, Wisconsin, or F.O.B. at a Miller authorized service facility as determined by Miller. Therefore no compensation or reimbursement for transportation costs of any kind will be allowed.

TO THE EXTENT PERMITTED BY LAW, THE REMEDIES PROVIDED HEREIN ARE THE SOLE AND EXCLUSIVE REMEDIES. IN NO EVENT SHALL MILLER BE LIABLE FOR DIRECT, INDIRECT, SPECIAL, INCIDENTAL OR CONSEQUENTIAL DAMAGES (INCLUDING LOSS OF PROFIT), WHETHER BASED ON CONTRACT, TORT OR ANY OTHER LEGAL THEORY.

ANY EXPRESS WARRANTY NOT PROVIDED HEREIN AND ANY IMPLIED WARRANTY, GUARANTY OR REPRESENTATION AS TO PERFORMANCE, AND ANY REMEDY FOR BREACH OF CONTRACT TORT OR ANY OTHER LEGAL THEORY WHICH, BUT FOR THIS PROVISION, MIGHT ARISE BY IMPLICATION, OPERATION OF LAW, CUSTOM OF TRADE OR COURSE OF DEALING, INCLUDING ANY IMPLIED WARRANTY OF MERCHANTABILITY OR FITNESS FOR PARTICULAR PURPOSE, WITH RESPECT TO ANY AND ALL EQUIPMENT FURNISHED BY MILLER IS EXCLUDED AND DISCLAIMED BY MILLER.

Some states in the U.S.A. do not allow limitations of how long an implied warranty lasts, or the exclusion of incidental, indirect, special or consequential damages, so the above limitation or exclusion may not apply to you. This warranty provides specific legal rights, and other rights may be available, but may vary from state to state.

In Canada, legislation in some provinces provides for certain additional warranties or remedies other than as stated herein, and to the extent that they may not be waived, the limitations and exclusions set out above may not apply. This Limited Warranty provides specific legal rights, and other rights may be available, but may vary from province to province.

miller_warr 2007-01





Owner's Record

Please complete and retain with your personal records.

Model Name

Serial/Style Number

Purchase Date

(Date which equipment was delivered to original customer.)

Distributor

Address

City

State

Zip



For Service

Contact a DISTRIBUTOR or SERVICE AGENCY near you.

Always provide Model Name and Serial/Style Number.

Contact your Distributor for:

Welding Supplies and Consumables

Options and Accessories

Personal Safety Equipment

Service and Repair

Replacement Parts

Training (Schools, Videos, Books)

Technical Manuals (Servicing Information and Parts)

Circuit Diagrams

Welding Process Handbooks

To locate a Distributor or Service Agency visit www.millerwelds.com or call 1-800-4-A-Miller

Contact the Delivering Carrier to:

File a claim for loss or damage during shipment.

For assistance in filing or settling claims, contact your distributor and/or equipment manufacturer's Transportation Department.

Miller Electric Mfg. Co.

An Illinois Tool Works Company
1635 West Spencer Street
Appleton, WI 54914 USA

International Headquarters—USA

USA Phone: 920-735-4505 Auto-Attended
USA & Canada FAX: 920-735-4134
International FAX: 920-735-4125

European Headquarters – United Kingdom

Phone: 44 (0) 1204-593493
FAX: 44 (0) 1204-598066

www.MillerWelds.com



Free Manuals Download Website

<http://myh66.com>

<http://usermanuals.us>

<http://www.somanuals.com>

<http://www.4manuals.cc>

<http://www.manual-lib.com>

<http://www.404manual.com>

<http://www.luxmanual.com>

<http://aubethermostatmanual.com>

Golf course search by state

<http://golfingnear.com>

Email search by domain

<http://emailbydomain.com>

Auto manuals search

<http://auto.somanuals.com>

TV manuals search

<http://tv.somanuals.com>