



TM-499C

August 2004

Eff. w/Serial Number LA124002 (Kohler)
Eff. w/Serial Number LB086216 (Honda)

Processes



Stick (SMAW) Welding

Description



Engine Driven Welding Generator

Blue Star[®] 6000

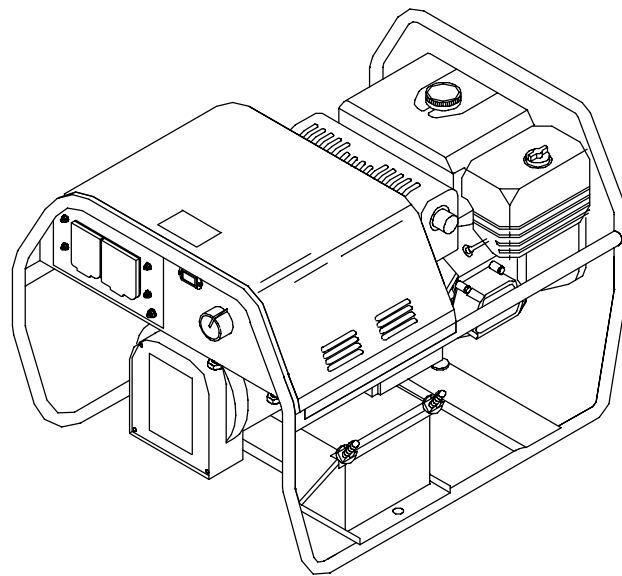

TECHNICAL MANUAL



Visit our website at
www.MillerWelds.com

TABLE OF CONTENTS

SECTION 1 – SAFETY PRECAUTIONS FOR SERVICING	1
1-1. Symbol Usage	1
1-2. Servicing Hazards	1
1-3. California Proposition 65 Warnings	2
1-4. EMF Information	2
SECTION 2 – DEFINITIONS	3
SECTION 3 – SPECIFICATIONS	3
3-1. Weld, Power, And Engine Specifications	3
3-2. Dimensions, Weights, And Operating Angles	4
3-3. Fuel Consumption (Kohler-Powered Units)	4
3-4. Fuel Consumption (Honda-Powered Units)	5
3-5. Duty Cycle	5
3-6. Generator Power Curves	6
3-7. Volt-Ampere Curves	7
SECTION 4 – INSTALLATION	8
4-1. Installing Welding Generator	8
4-2. Grounding Generator To Truck Or Trailer Frame	8
4-3. Grounding Generator When Supplying Building Systems	9
4-4. Engine Prestart Checks (Kohler-Powered Units)	9
4-5. Engine Prestart Checks (Honda-Powered Units)	10
4-6. Connecting The Battery (Electric-Start Models Only)	10
4-7. Connecting To Weld Output Terminals	11
4-8. Selecting Weld Cable Sizes*	11
SECTION 5 – OPERATING THE WELDING GENERATOR	12
5-1. Controls (Kohler-Powered Units)	12
5-2. Controls (Honda-Powered Units) (See Section 5-3)	13
5-3. Description Of Controls (Honda-Powered Units) (See Section 5-2)	14
SECTION 6 – OPERATING AUXILIARY EQUIPMENT	15
6-1. Generator Power Panel 495 218 (USA)	15
6-2. Optional Generator Power Panels	16
6-3. Generator Power Panel Ratings	17
6-4. Wiring Instructions For Optional 120/240 Volt Twistlock Plug (NEMA L14-30P)	18
SECTION 7 – MAINTENANCE	18
7-1. Maintenance Label	18
7-2. Routine Maintenance	19
7-3. Overload Protection (Honda-Powered Units)	20
7-4. Adjusting Engine Speed (Kohler-Powered Units)	20
7-5. Adjusting Engine Speed (Honda-Powered Units)	21
SECTION 8 – THEORY OF OPERATION	22
SECTION 9 – EXPLANATION OF ELECTRICAL PARTS	24
SECTION 10 – TROUBLESHOOTING	31
10-1. Troubleshooting Tables	31
10-2. Troubleshooting Circuit Diagram For Welding Generator (Use With Section 10-3)	36
10-3. Test Points And Values (Use With Section 10-2)	38
10-4. Waveforms For Section 10-2	39
10-5. Control Board PC1 Testing Information	40
10-6. Control Board PC1 Test Point Values	41
10-7. Replacing Brushes And Cleaning Slip Rings	42
10-8. Checking Unit Output After Servicing	43

TABLE OF CONTENTS

SECTION 11 – DISASSEMBLY AND REASSEMBLY	44
11-1. Disassembly Of Unit	44
11-2. Removing Rotor And Reassembling Generator	45
SECTION 12 – ELECTRICAL DIAGRAMS	46
SECTION 13 – PARTS LIST FOR LA124002 THRU LB111747 (KOHLER ONLY)	54
SECTION 14 – PARTS LIST FOR LB111748 THRU LC061260 (KOHLER) AND LB086216 THRU LC061260 (HONDA)	58
SECTION 15 – PARTS LIST FOR LC061261 THRU LC552236 (KOHLER & HONDA)	64
SECTION 16 – PARTS LIST FOR LC552237 AND FOLLOWING	70

SECTION 1 – SAFETY PRECAUTIONS FOR SERVICING

1-1. Symbol Usage

OM-499H, safety_rtm 8/03



Means Warning! Watch Out! There are possible hazards with this procedure! The possible hazards are shown in the adjoining symbols.

▲ Marks a special safety message.

☞ Means "Note"; not safety related.



This group of symbols means Warning! Watch Out! possible ELECTRIC SHOCK, MOVING PARTS, and HOT PARTS hazards. Consult symbols and related instructions below for necessary actions to avoid the hazards.

1-2. Servicing Hazards

▲ The symbols shown below are used throughout this manual to call attention to and identify possible hazards. When you see the symbol, watch out, and follow the related instructions to avoid the hazard.

▲ Only qualified persons should test, maintain, and repair this unit.

▲ During servicing, keep everybody, especially children, away.



ELECTRIC SHOCK can kill.

- Do not touch live electrical parts.
- Stop engine before testing or repairing unit unless the procedure specifically requires an energized unit.
- Insulate yourself from ground by standing or working on dry insulating mats big enough to prevent contact with the ground.
- Do not leave live unit unattended.
- When testing live unit, use the one-hand method. Do not put both hands inside unit. Keep one hand free.

SIGNIFICANT DC VOLTAGE exists after stopping engine on inverters.

- Stop engine on inverter and discharge input capacitors according to instructions in Maintenance Section before touching any parts.



MOVING PARTS can cause injury.

- Keep away from moving parts such as fans, belts, and rotors.
- Have only qualified people remove guards or covers for maintenance and troubleshooting as necessary.
- Keep hands, hair, loose clothing, and tools away from moving parts.
- Before working on generator, remove spark plugs or injectors to keep engine from kicking back or starting.
- Block flywheel so that it will not turn while working on generator components.
- Reinstall panels or guards and close doors when servicing is finished and before starting engine.

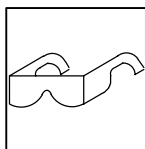

FLYING METAL can injure eyes.

- Wear safety glasses with side shields or face shield during servicing.
- Be careful not to short metal tools, parts, or wires together during testing and servicing.

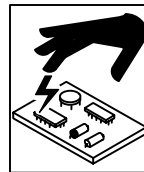

STATIC (ESD) can damage PC boards.

- Put on grounded wrist strap BEFORE handling boards or parts.
- Use proper static-proof bags and boxes to store, move, or ship PC boards.

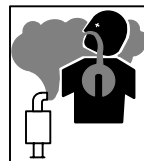

ENGINE EXHAUST GASES can kill.

- Do not breathe exhaust fumes.
- Use in open, well-ventilated areas, or vent exhaust outside and away from any building air intakes.



FUEL can cause fire or explosion.

- Stop engine and let it cool off before checking or adding fuel.
- Do not add fuel while smoking or if unit is near any sparks or open flames.
- Do not overfill tank; clean up any spilled fuel.

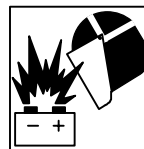

BATTERY EXPLOSION can BLIND.

- Always wear a face shield, rubber gloves, and protective clothing when working on a battery.
- Stop engine before disconnecting or connecting battery cables.
- Do not allow tools to cause sparks when working on a battery.
- Do not use welder to charge batteries or jump start vehicles.
- Observe correct polarity (+ and -) on batteries.
- Disconnect negative (-) cable first and connect it last.



BATTERY ACID can BURN SKIN and EYES.

- Do not tip battery.
- Replace damaged battery.
- Flush eyes and skin immediately with water.

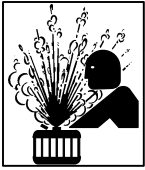

STEAM AND HOT COOLANT can burn.

- If possible, check coolant level when engine is cold to avoid scalding.
- Always check coolant level at overflow tank, if present on unit, instead of radiator.
- If the engine is warm, checking is needed, and there is no overflow tank, follow the next two statements.

- Wear safety glasses and gloves and put a rag over radiator cap.
- Turn cap slightly and let pressure escape slowly before completely removing cap.



MAGNETIC FIELDS can affect pacemakers.

- Pacemaker wearers keep away from servicing areas until consulting your doctor.



FALLING UNIT can cause injury.

- Use equipment of adequate capacity to lift and support unit and components.
- Use lifting eye to lift unit only, NOT running gear, gas cylinders, or any other accessories.
- Securely attach components to lifting equipment.

- If using lift forks to move unit, be sure forks are long enough to extend beyond opposite side of unit.



HOT PARTS can cause severe burns.

- Allow cooling period before servicing.
- Wear protective gloves and clothing when working on a hot engine.
- Do not touch hot engine parts bare-handed.

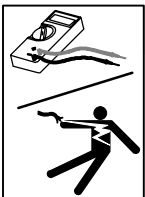

SHOCK HAZARD from testing.

- Stop engine before making or changing meter lead connections.
- Use at least one meter lead that has a self-retaining spring clip such as an alligator clip.
- Read instructions for test equipment.



TILTING OR TIPPING can cause injury.

- Do not put any body part under unit while lifting.
- Always use proper equipment (hoists, slings, chains, blocks, etc.) of adequate capacity to lift and support components (stator, rotor, engine, etc.) as needed during job.

PINCH POINTS can injure.

- Be careful when working on stator and rotor assemblies.

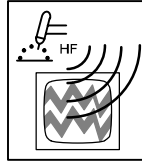

H.F. RADIATION can cause interference.

- High-frequency (H.F.) can interfere with radio navigation, safety services, computers, and communications equipment.
- Have only qualified persons familiar with electronic equipment perform this installation.
- The user is responsible for having a qualified electrician promptly correct any interference problem resulting from the installation.
- If notified by the FCC about interference, stop using the equipment at once.
- Have the installation regularly checked and maintained.
- Keep high-frequency source doors and panels tightly shut, keep spark gaps at correct setting, and use grounding and shielding to minimize the possibility of interference.

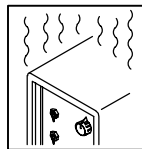

OVERUSE can cause OVERHEATING.

- Allow cooling period; follow rated duty cycle.
- Reduce current or reduce duty cycle before starting to weld again.
- Do not block or filter airflow to unit.

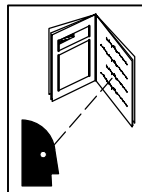

READ INSTRUCTIONS.

- Use Testing Booklet (Part No. 150 853) when servicing this unit.
- Consult the Owner's Manual for welding safety precautions.
- Use only genuine replacement parts.
- Reinstall injectors and bleed air from fuel system according to engine manual.

1-3. California Proposition 65 Warnings

- ▲ **Welding or cutting equipment produces fumes or gases which contain chemicals known to the State of California to cause birth defects and, in some cases, cancer. (California Health & Safety Code Section 25249.5 et seq.)**
- ▲ **Battery posts, terminals and related accessories contain lead and lead compounds, chemicals known to the State of California to cause cancer and birth defects or other reproductive harm. Wash hands after handling.**

1-4. EMF Information

Considerations About Welding And The Effects Of Low Frequency Electric And Magnetic Fields

Welding current, as it flows through welding cables, will cause electromagnetic fields. There has been and still is some concern about such fields. However, after examining more than 500 studies spanning 17 years of research, a special blue ribbon committee of the National Research Council concluded that: "The body of evidence, in the committee's judgment, has not demonstrated that exposure to power-frequency electric and magnetic fields is a human-health hazard." However, studies are still going forth and evidence continues to be examined. Until the final conclusions of the research are reached, you may wish to minimize your exposure to electromagnetic fields when welding or cutting.

To reduce magnetic fields in the workplace, use the following procedures:











1. Keep cables close together by twisting or taping them.
2. Arrange cables to one side and away from the operator.
3. Do not coil or drape cables around your body.
4. Keep welding power source and cables as far away from operator as practical.
5. Connect work clamp to workpiece as close to the weld as possible.

About Pacemakers:

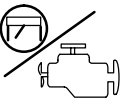
Pacemaker wearers consult your doctor first. If cleared by your doctor, then following the above procedures is recommended.

SECTION 2 – DEFINITIONS

2-1. Symbol Definitions

	Engine Choke		Read Operator's Manual	A	Amperes	V	Volts
	Engine Oil		Fuel		Battery (Engine)		Engine
+	Positive	—	Negative		Alternating Current (AC)		Output
h	Hours	s	Seconds		Time		Protective Earth (Ground)
	Circuit Breaker		Temperature				

SECTION 3 – SPECIFICATIONS

NOTE

This unit uses either a Kohler or a Honda engine. Differences between models are noted throughout this manual.

3-1. Weld, Power, And Engine Specifications

Welding Mode	Weld Output Range	Rated Welding Output	Maximum Open Circuit Voltage	Generator Power Rating	Fuel Capacity	Engine
CC/DC	40 – 180 A (60 Hz) 40 – 160 A (50 Hz)	180 A, 25 V, 30% Duty Cycle 130 A, 25 V, 60% Duty Cycle 100 A, 25 V, 100% Duty Cycle	80 (60 Hz) 70 (50 Hz)	Single-Phase, 6 kVA/kW (Peak) 5.5 kVA/kW (Continuous) 50/25 A, 110/220 V AC, 50 Hz 120/240 V AC, 60 Hz	Kohler: 1.8 gal (6.9 L) Tank Honda: 1.7 gal (6.4 L) Tank	Kohler CS12STG Air-Cooled, One-Cylinder, Four-Cycle, 12 HP (360 CC), Gasoline Engine OR Honda GX390 Air-Cooled, One-Cylinder, Four-Cycle, 13 HP (390 CC), Gasoline Engine

3-2. Dimensions, Weights, And Operating Angles

Dimensions	
Height	20-3/4 in (527 mm)
Width	22-3/4 in (577 mm)
Depth	31-1/4 in (793 mm)
A	31-1/4 in (793 mm)
B	10-1/2 in (268 mm)
C	13-45/64 in (348 mm)
D	22-3/4 in (577 mm)
E	1-3/4 in (44 mm)
F	19-1/2 in (495 mm)
G	13/32 in (10 mm) Dia.
Weight	
Kohler: 265 lb (120 kg)	
Honda Electric-Start Model: 278 lb (126 kg)	
Honda Recoil-Start Model: 253 lb (114 kg)	

▲ Do not exceed tilt angles or engine could be damaged or unit could tip.

▲ Do not move or operate unit where it could tip.

802 096 802 524-A

3-3. Fuel Consumption (Kohler-Powered Units)

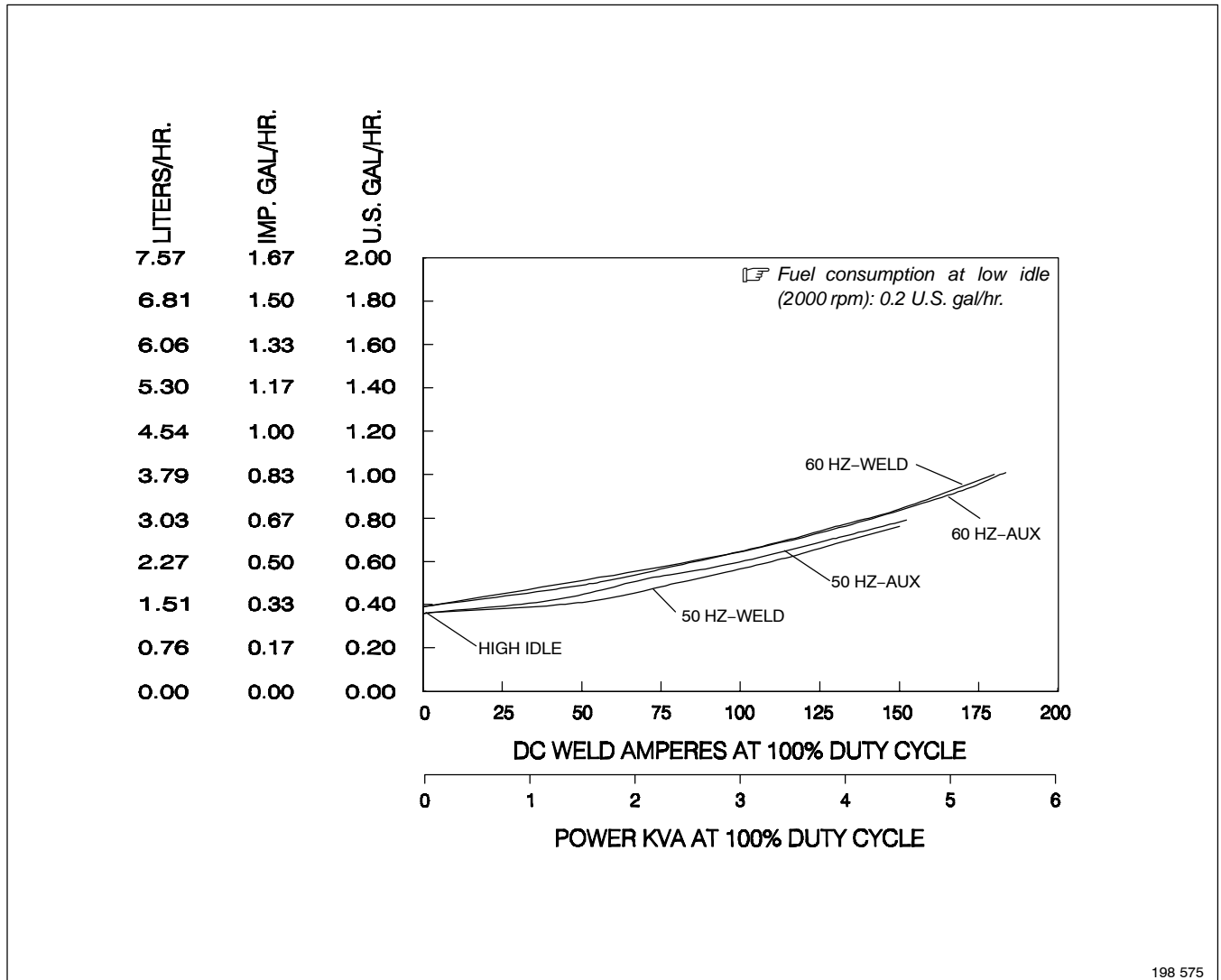

3-4. Fuel Consumption (Honda-Powered Units)

LITERS/HR.	IMP. GAL/HR.	U.S. GAL/HR.
7.57	1.67	2.00
6.81	1.50	1.80
6.06	1.33	1.60
5.30	1.17	1.40
4.54	1.00	1.20
3.79	0.83	1.00
3.03	0.67	0.80
2.27	0.50	0.60
1.51	0.33	0.40
0.76	0.17	0.20
0.00	0.00	0.00

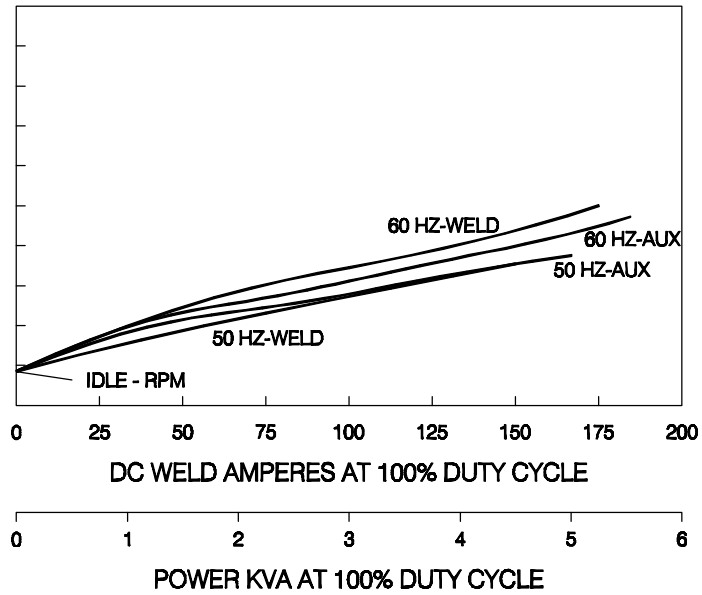

802 122

3-5. Duty Cycle

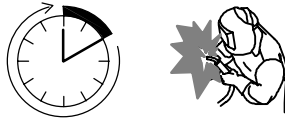

Continuous Welding
100% Duty Cycle at 100 Amperes CC/DC

Duty cycle is the percentage of 10 minutes that unit can weld at rated load without overheating.

▲ Exceeding duty cycle can damage unit and void warranty.

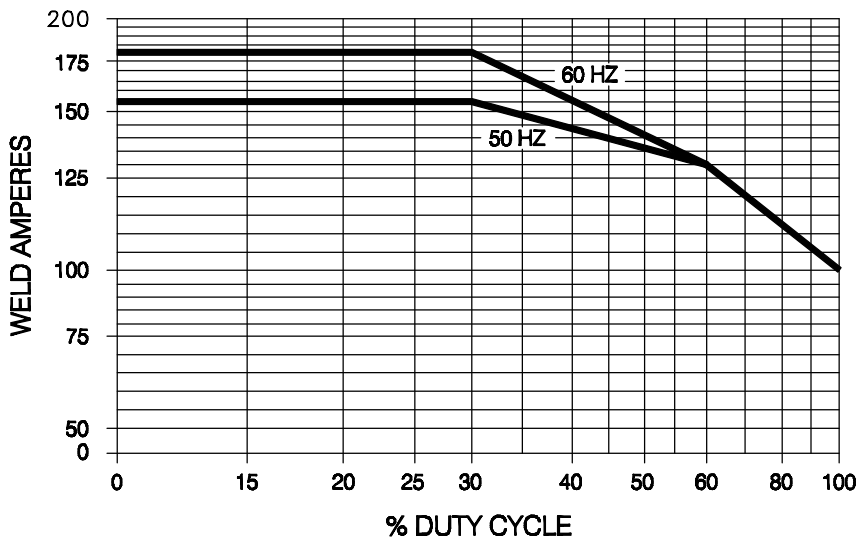

802 093

3-6. Generator Power Curves

The generator power curves show the ac power available in amperes at the receptacles.

A. 60 Hz Model

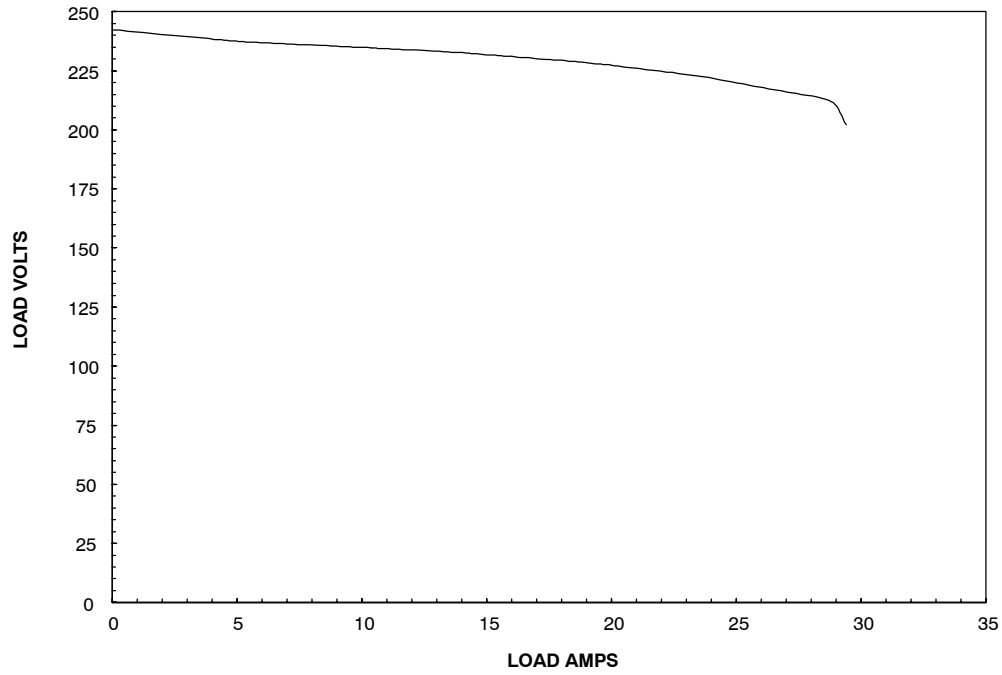

B. 50 Hz Model

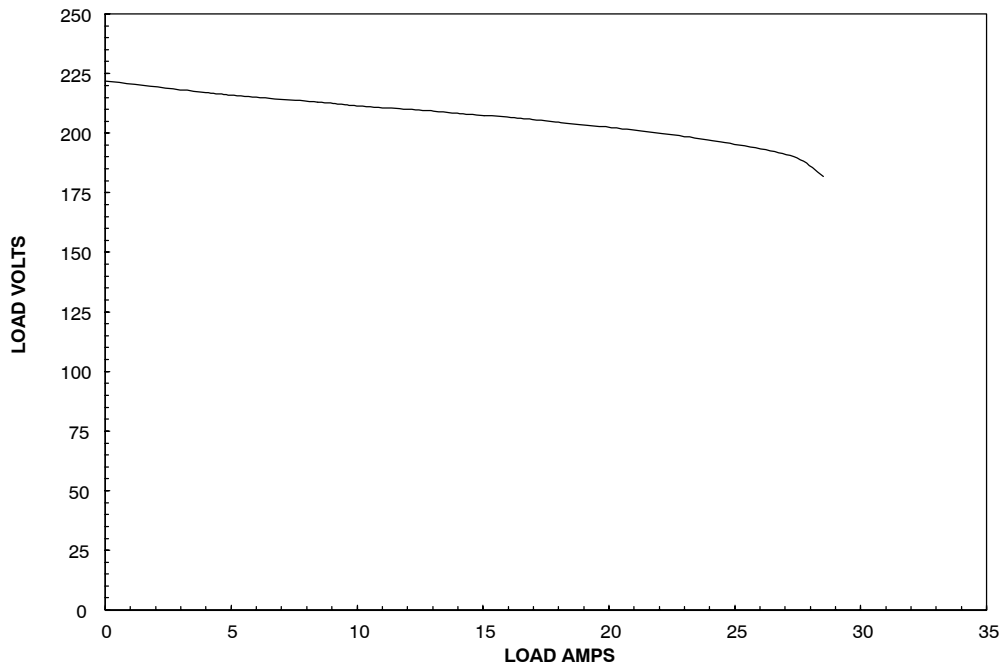

3-7. Volt-Ampere Curves

The volt-ampere curve shows the minimum and maximum voltage and amperage output capabilities of the welding generator. Curves of all other settings fall between the curves shown.

A. 60 Hz Model

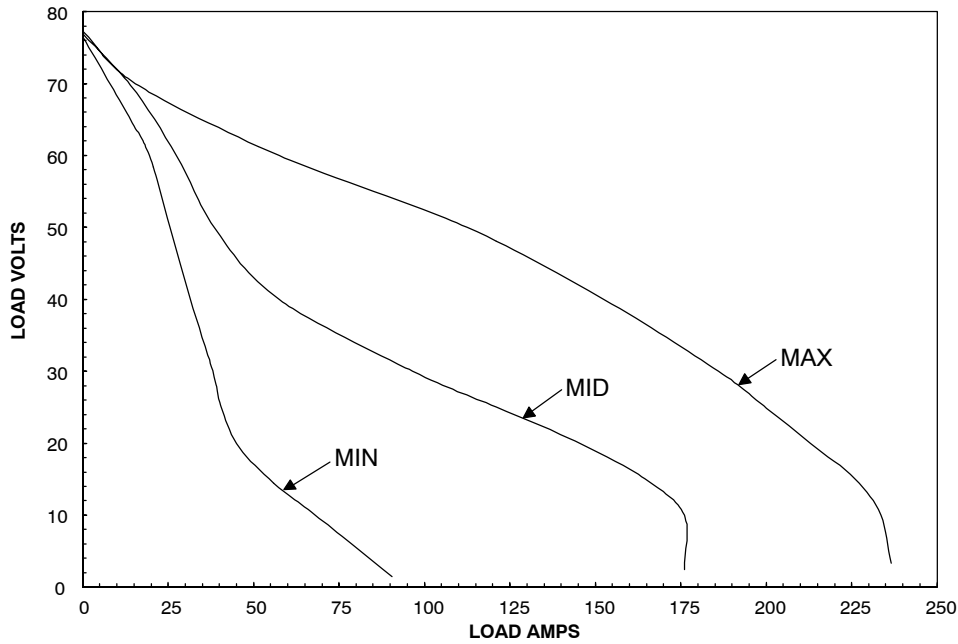

B. 50 Hz Model

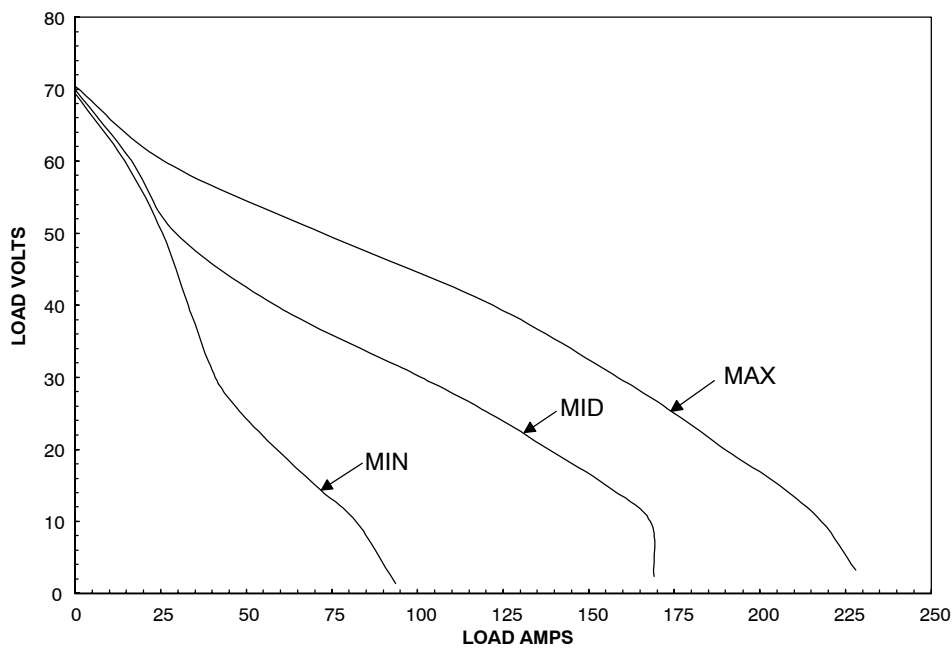

SECTION 4 – INSTALLATION

4-1. Installing Welding Generator

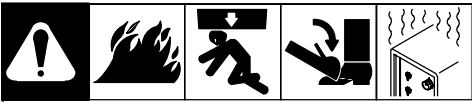

▲ Always securely fasten welding generator onto transport vehicle or trailer and comply with all DOT and other applicable codes.

Movement

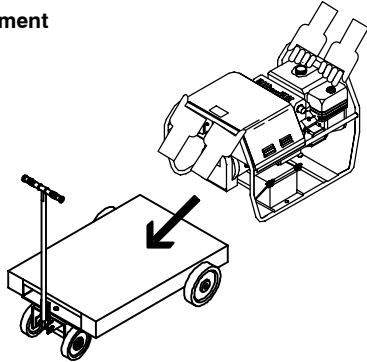

Airflow Clearance

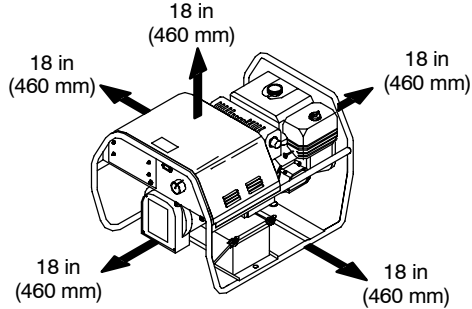

Location

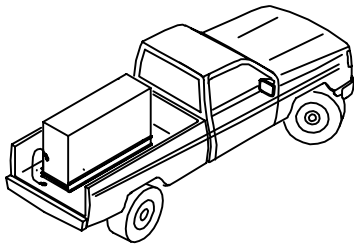

OR

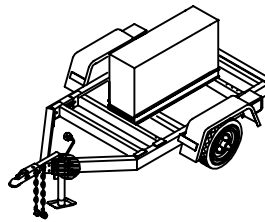

install1 10/00* – 802 524-A / Ref. 151 556 / 158 936-A / S-0854

4-2. Grounding Generator To Truck Or Trailer Frame



▲ Always ground generator frame to vehicle frame to prevent electric shock and static electricity hazards.

- 1 Generator Base
- 2 Metal Vehicle Frame
- 3 Equipment Grounding Terminal
- 4 Grounding Cable

Use #10 AWG or larger insulated copper wire.

▲ If unit does not have GFCI receptacles, use GFCI-protected extension cord.

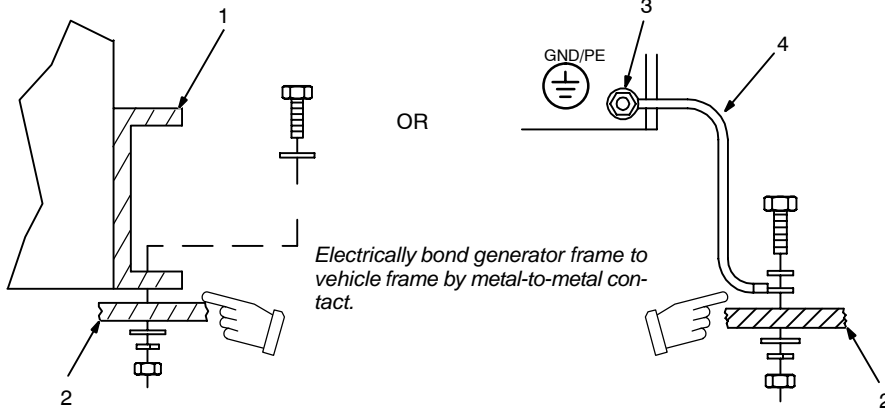

install1 10/00* – Ref. 151 556 / S-0854

4-3. Grounding Generator When Supplying Building Systems

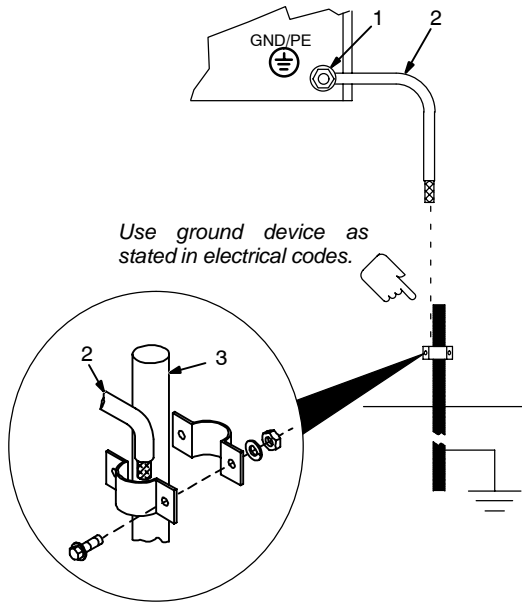

- 1 Equipment Grounding Terminal
 - 2 Grounding Cable
- Use #10 AWG or larger insulated copper wire.
- 3 Ground Device
- ▲ **Ground generator to system earth ground if supplying power to a premises (home, shop, farm) wiring system.**

800 576-B

4-4. Engine Prestart Checks (Kohler-Powered Units)

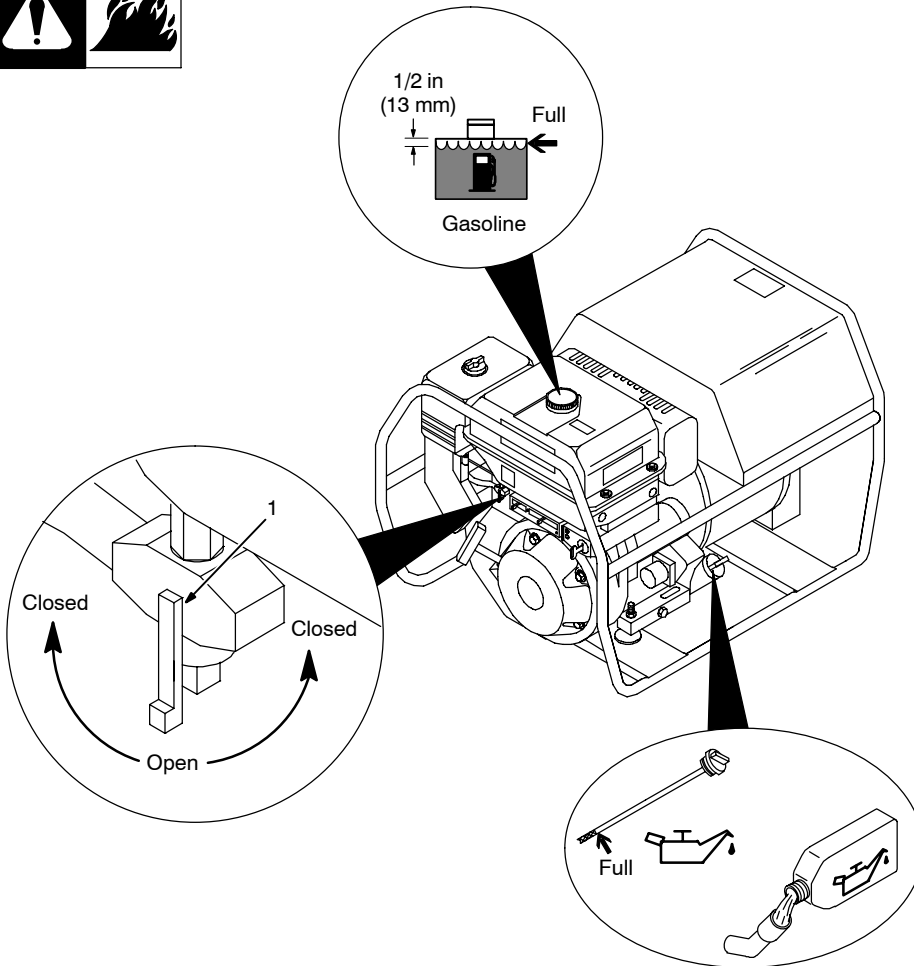

☞ Follow run-in procedure in engine manual.

Check all fluids daily. Engine must be cold and on a level surface. Unit is shipped with 10W30 engine oil.

Engine stops if oil level gets too low.

☞ This unit has a low oil level shutdown switch. However, some conditions may cause engine damage before the engine shuts down. Check oil level often and do not use the oil level shutdown system to monitor oil level.

1 Fuel Valve

Open valve by turning lever to vertical position.

☞ Close fuel valve before moving unit or carburetor may flood and make starting difficult.

Fuel

Add fresh fuel before starting engine the first time (see maintenance label for specifications). Fill fuel tank up to 1/2 in. (13 mm) from top to allow room for expansion. Check fuel level on a cold engine before use each day.

Oil

After fueling, check oil with unit on level surface. If oil is not up to full mark on dipstick, add oil (see maintenance label).

☞ To improve cold weather starting:

Keep battery in good condition. Store battery in warm area.

Use correct grade oil for cold weather.

802 511-A

4-5. Engine Prestart Checks (Honda-Powered Units)

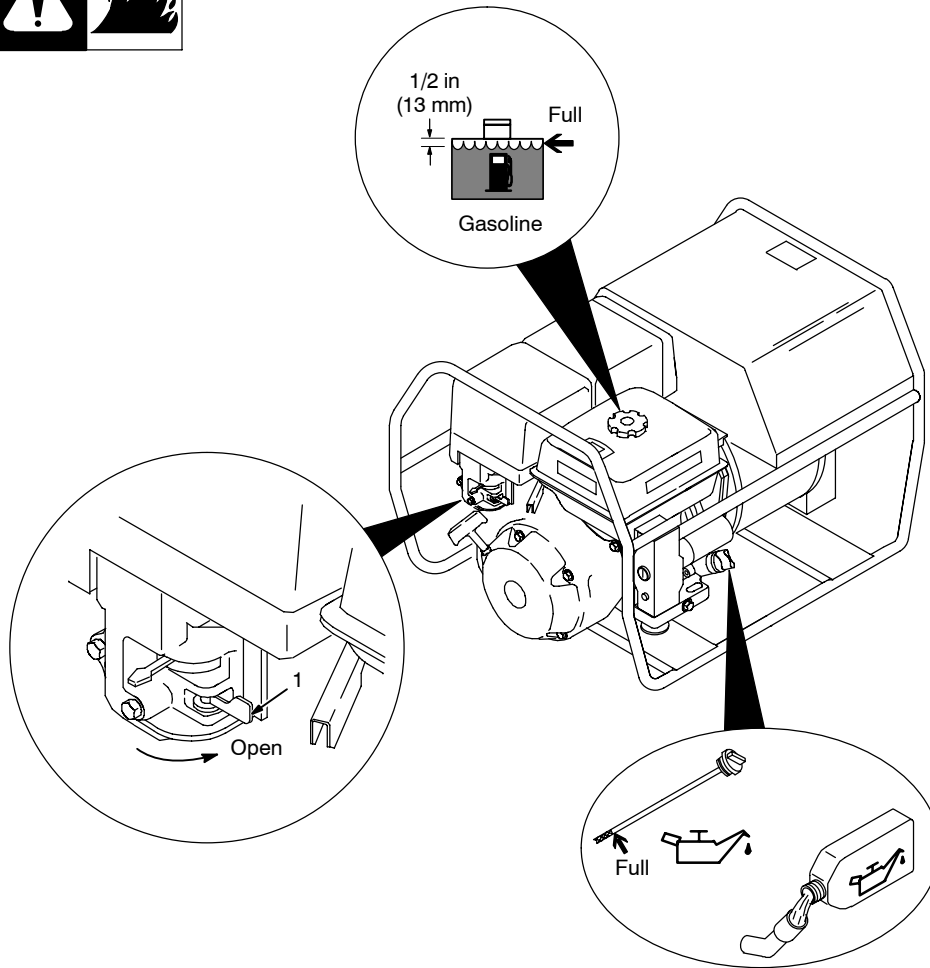

Check all fluids daily. Engine must be cold and on a level surface. Unit is shipped with 10W30 engine oil.

Engine stops if oil level gets too low.

☞ Follow run-in procedure in engine manual.

1 Fuel Valve

Open valve.

☞ Close fuel valve before moving unit or carburetor may flood and make starting difficult.

Fuel

Add fresh fuel before starting engine the first time (see maintenance label for specifications). Fill fuel tank up to 1/2 in. (13 mm) from top to allow room for expansion. Check fuel level on a cold engine before use each day.

Oil

After fueling, check oil with unit on level surface. If oil is not up to full mark on dipstick, add oil (see maintenance label).

☞ To improve cold weather starting:

Keep battery in good condition. Store battery in warm area.

Use correct grade oil for cold weather.

802 094-A

4-6. Connecting The Battery (Electric-Start Models Only)

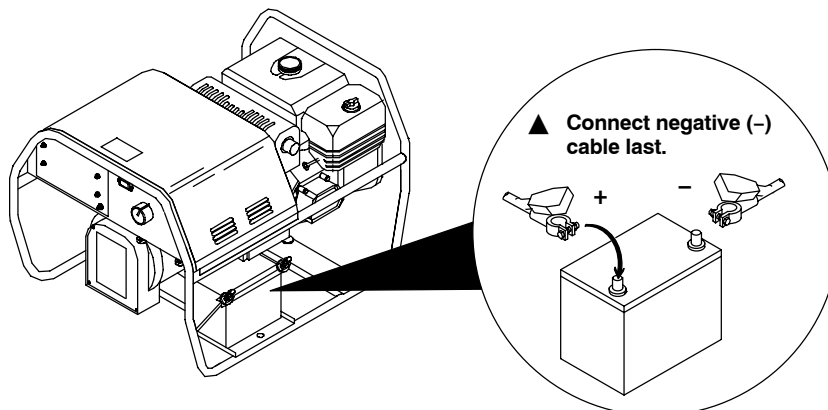

▲ Turn Engine Switch to Off (electric-start models only).

Tools Needed:

3/8, 1/2 in

802 524 / Ref. S-0756-D

4-7. Connecting To Weld Output Terminals



- 1 Positive (+) Weld Output Terminal
- 2 Negative (-) Weld Output Terminal

For Direct Current Electrode Positive (DCEP), connect work cable to Negative (-) terminal and electrode holder to Positive (+) terminal.

For Direct Current Electrode negative (DCEN), reverse cable connections.

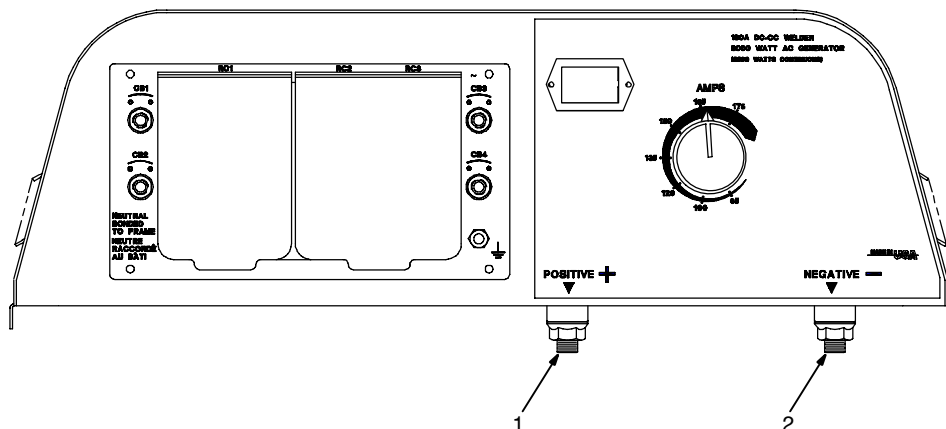

Tools Needed:

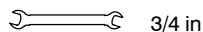

196 914 / 495 178

4-8. Selecting Weld Cable Sizes*

 Weld Output Terminals ▲ Stop engine before connecting to weld output terminals. ▲ Do not use worn, damaged, undersized, or poorly spliced cables.	Weld Cable Size** and Total Cable (Copper) Length in Weld Circuit Not Exceeding***								
	Welding Amperes	100 ft (30 m) or Less		150 ft (45 m)	200 ft (60 m)	250 ft (70 m)	300 ft (90 m)	350 ft (105 m)	400 ft (120 m)
		10 – 60% Duty Cycle	60 – 100% Duty Cycle	10 – 100% Duty Cycle					
100	4 (20)	4 (20)	4 (20)	3 (30)	2 (35)	1 (50)	1/0 (60)	1/0 (60)	
150	3 (30)	3 (30)	2 (35)	1 (50)	1/0 (60)	2/0 (70)	3/0 (95)	3/0 (95)	
200	3 (30)	2 (35)	1 (50)	1/0 (60)	2/0 (70)	3/0 (95)	4/0 (120)	4/0 (120)	
250	2 (35)	1 (50)	1/0 (60)	2/0 (70)	3/0 (95)	4/0 (120)	2 ea. 2/0 (2x70)	2 ea. 2/0 (2x70)	

* This chart is a general guideline and may not suit all applications. If cable overheating occurs (normally you can smell it), use next size larger cable.

**Weld cable size (AWG) is based on either a 4 volts or less drop or a current density of at least 300 circular mils per ampere.
() = mm² for metric use

S-0007-E

***For distances longer than those shown in this guide, call a factory applications representative at 920-735-4505.

SECTION 5 – OPERATING THE WELDING GENERATOR

5-1. Controls (Kohler-Powered Units)

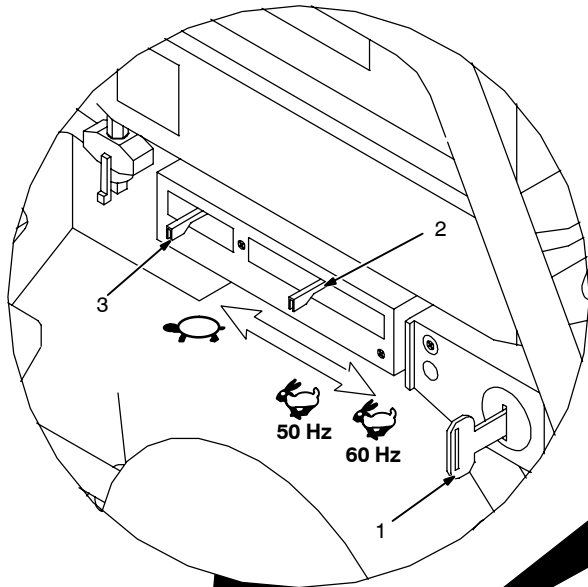
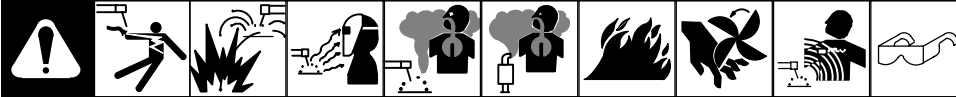

WELDING RANGE CHART				
DIAMETER				
3/32				
1/8				
5/32				
3/16				
E-6010	50-80	75-130	110-165	140-MAX
E-6011	50-70	75-130	120-160	160-MAX
E-6013	50-85	90-120	130-150	150-MAX
E-7014	70-90	120-145	145-MAX	
E-7018	75-100	90-150	115-MAX	150-MAX
E-308L-16	35-80	55-115	85-145	95-MAX

495187

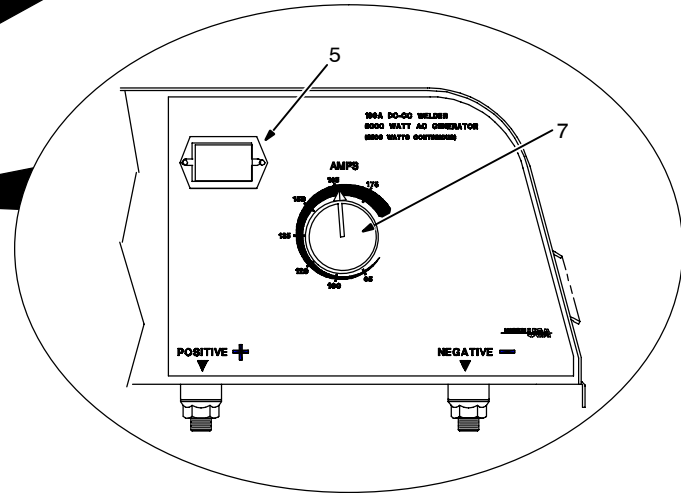
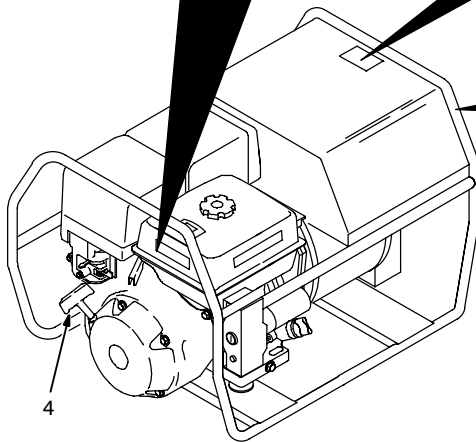

802 511-A / 802 0511 / 495 178

☞ *Weld and generator power output stops if generator overheats or engine speed is too low.*

1 Engine Switch

Use switch to open ignition circuit, and to stop engine.

2 Throttle Control Lever

Use lever to select engine speed. Use 50 Hz or 60 Hz position for 50 or 60 Hz generator power. Use 60 Hz position for maximum weld output.

3 Choke Control Lever

Use lever to change engine air/fuel mix. Move lever to right if starting a cold engine. Move lever to left if starting a warm engine.

To Start (Electric): open fuel valve (see Section 4-4), move throttle lever to Idle, set choke, and turn engine switch to Start position. Open choke as engine warms. If engine does not crank, use recoil starting procedure following to start engine.

▲ **If engine does not start, let engine come to a complete stop before attempting restart.**

4 Starter Handle

To Start (Recoil): open fuel valve (see Section 4-4), move throttle lever to Idle, set choke, and pull starter handle. Open choke as engine warms.

To Stop: turn engine switch to Off.

☞ *Always close fuel valve after stopping unit. Moving unit with fuel valve open may cause carburetor flooding and make starting difficult.*

5 Engine Hour Meter

6 Welding Range Label

Use label to determine correct weld amperage based on electrode size, type, and material thickness.

7 Current Control

Use control to select weld amperage. Control may be adjusted while welding.

To Set Current Control: Use label to determine correct size electrode for material thickness. Select electrode type and set current control to corresponding amperage range. Adjust control to obtain desired weld performance.

EXAMPLE:

Material Thickness: 1/8 to 1/4 in

Electrode Diameter: 1/8

Electrode Type: E-6013

Current Control Setting: 90 - 120 A

5-2. Controls (Honda-Powered Units) (See Section 5-3)

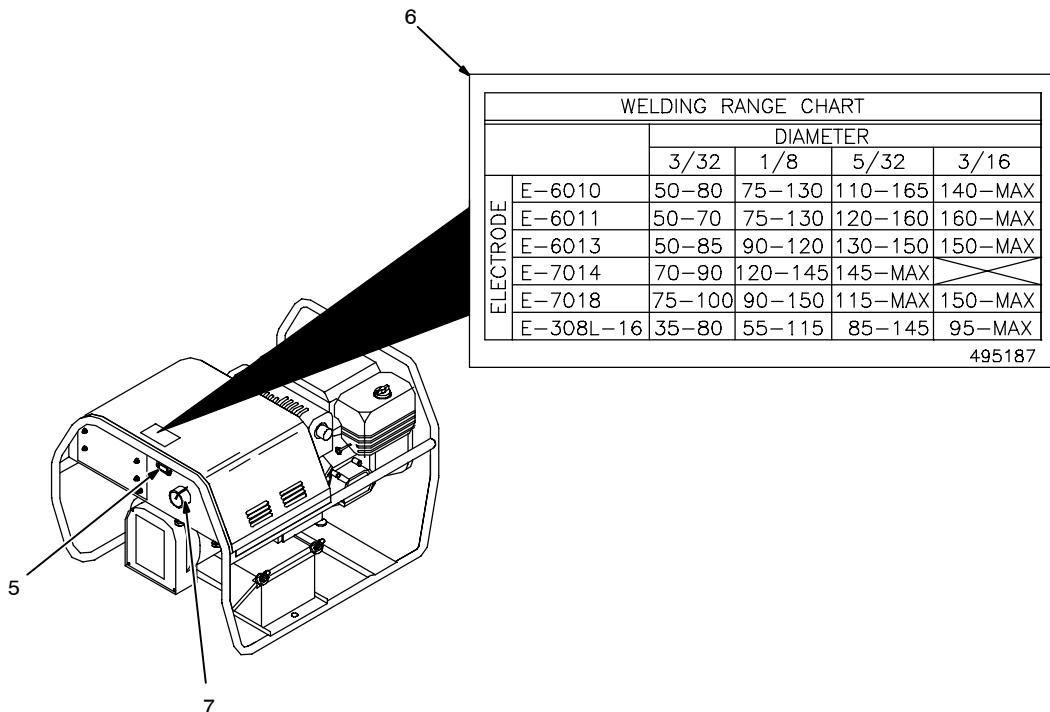
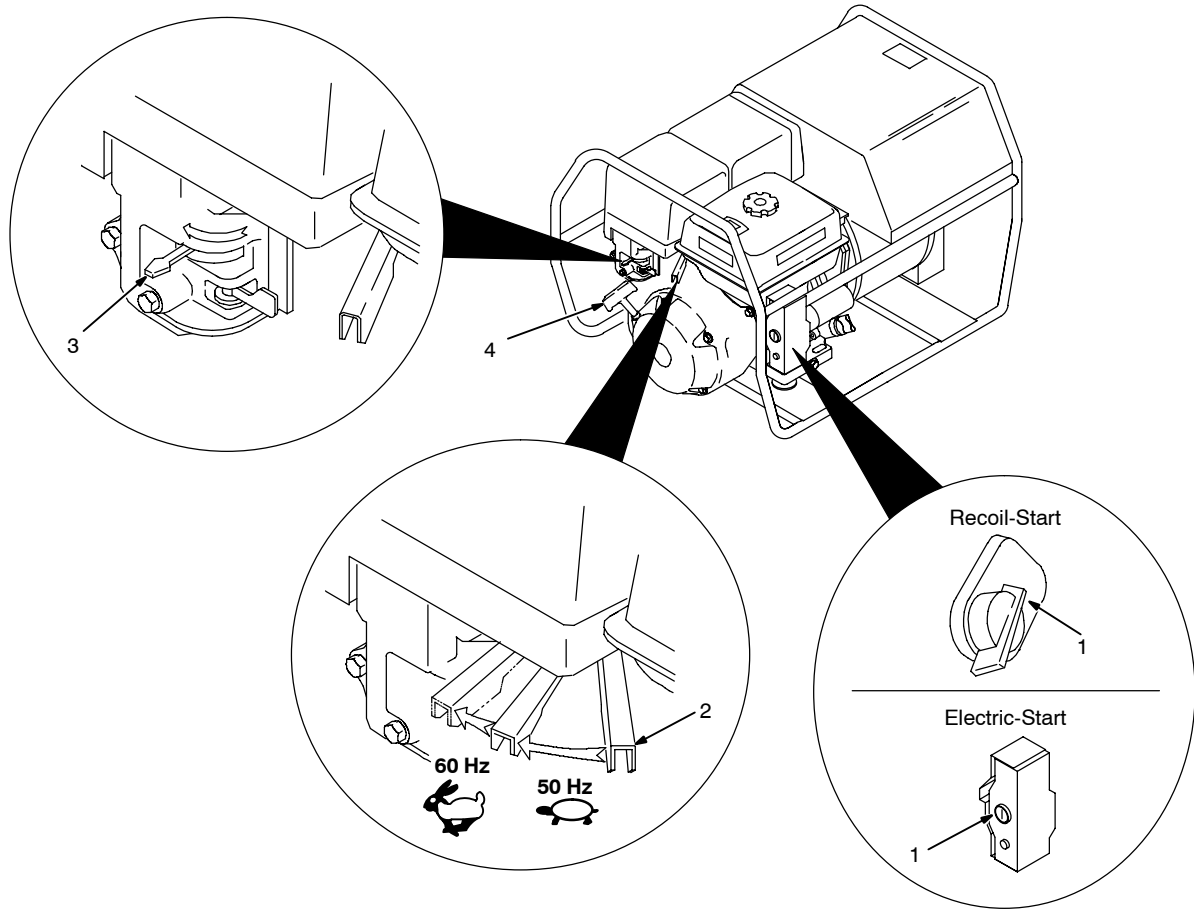

SECTION 6 – OPERATING AUXILIARY EQUIPMENT

NOTE

The welding generator provides power while welding and with the Current control in any position. However, under these conditions equipment connected to the welding generator may be subject to larger than normal voltage fluctuations. It is recommended that only lamps be powered under these conditions.

6-1. Generator Power Panel 495 218 (USA)

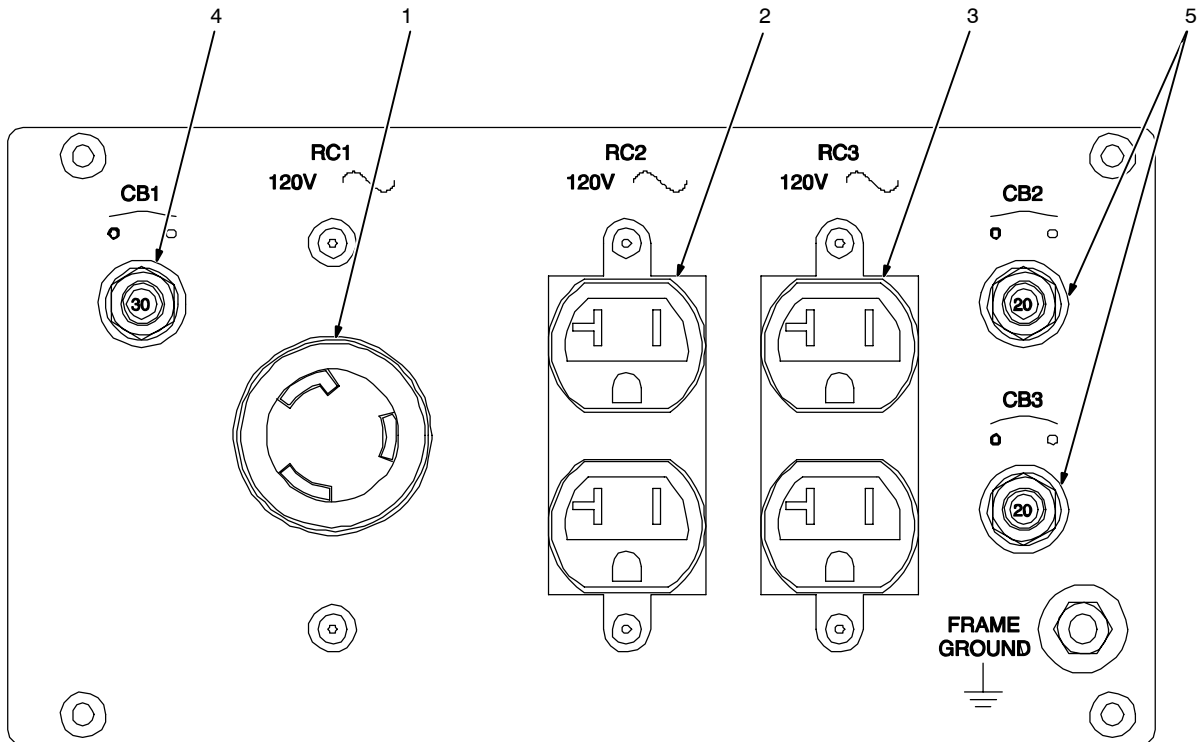

495 218

▲ If unit does not have GFCI receptacles, use GFCI-protected extension cord.

▲ Power is still present at the 240 volt receptacle when only one circuit breaker trips.

Unplug power cord before attempting to service accessories or tools.

 Generator power decreases as weld current increases.

Set Amperage control at max. for full generator power.

 Place throttle lever in Run position (far right) for generator power.

1 120 V AC Twistlock Receptacle RC1

RC1 supplies 60 Hz single-phase power at weld/power speed. Maximum output is 3.5 kVA/kW.

2 120 V 20 A AC Duplex Receptacle RC2

3 120 V 20 A AC Duplex Receptacle RC3

RC2 and RC3 supply 60 Hz single-phase power at weld/power speed. Maximum output from RC2 or RC3 is 2.4 kVA/kW.

 Each receptacle of the duplex can provide 15A/1800W.

 Do not parallel the two 120V duplex receptacles.

4 Circuit Breaker CB1

CB1 protects RC1 from overload. If CB1 opens, RC1 does not work.

5 Circuit Breakers CB2 And CB3

CB2 protects RC2 and CB3 protects RC3 from overload. If a circuit breaker opens, the receptacle does not work.

 Press button to reset circuit breaker.

Combined output of all receptacles limited to 6 kVA/kW rating of the generator. (See Generator Power Guidelines in Owner's Manual.)

EXAMPLE: If 10 A is drawn from each 120 volt duplex receptacle, only 9 A is available from the 120 V twistlock receptacle.

$2 \times (120 \text{ V} \times 10 \text{ A}) + (240 \text{ V} \times 9 \text{ A}) = 3.5 \text{ kVA/KW.}$

6-2. Optional Generator Power Panels

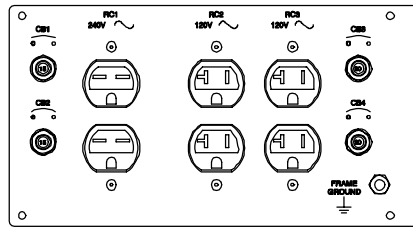

**Generator Power Panel 495 315
(USA)**

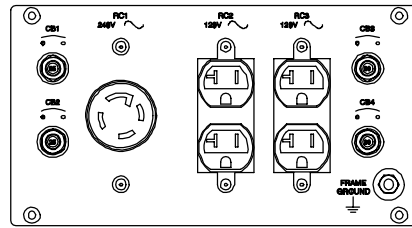

**Generator Power Panel 495 219
(USA)**

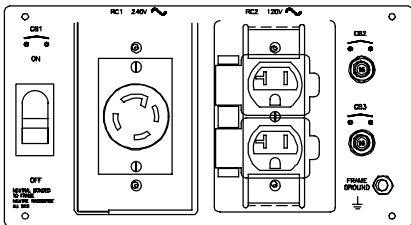

**Generator Power Panel 495 278
(Canada-CSA)**

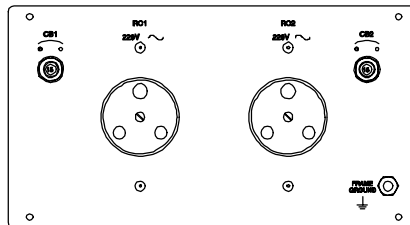

**Generator Power Panel 495 253
(South Africa)**

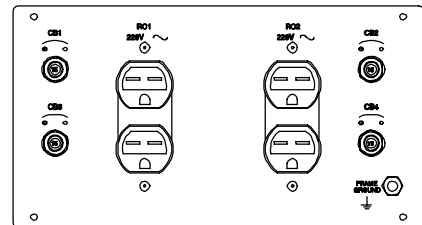

**Generator Power Panel 495 288
(South America)**

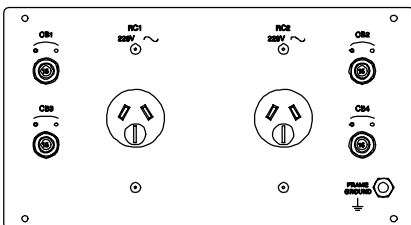

**Generator Power Panel 495 289
(Australia)**

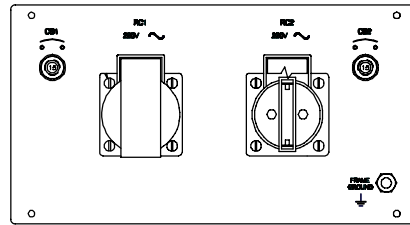

**Generator Power Panel 495 290
(Europe)**

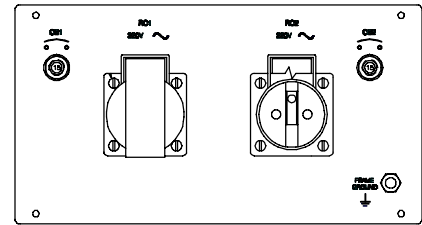

**Generator Power Panel 495 283
(S.E. Asia)**

Ref. ST-802 124 / H-495 290 / H-495 283 / 495 277

▲ If unit does not have GFCI receptacles, use GFCI-protected extension cord.

▲ Power may still be present at a receptacle when a circuit breaker trips.

Unplug power cord before attempting to service accessories or tools.

☞ Generator power decreases as weld current increases.

Set Amperage control at max. for full generator power.

☞ Place throttle lever in Run position (far right) for generator power.

Circuit breakers protect the generator from overload.

☞ Press button to reset circuit breaker.

6-3. Generator Power Panel Ratings



NOTE

Unless otherwise stated, the rating of duplex outlets is the combined load of all receptacles.

Total power from generator NOT to exceed 5500 Watts (60 Hz) or 5000 Watts (50 Hz)

Receptacle	Protected By	Panel 495 218 (USA)	Panel 495 315 (USA)	Panel 495 219 (USA)	Panel 495 278 (Canada-CSA)	Panel 495 253 (S. Africa)	Panel 495 288 (South America)	Panel 495 289 (Australia)	Panel 495 290 (Europe)	Panel 495 283 (S.E. Asia)
		60 Hz	60 Hz	60 Hz	60 Hz	50 Hz	50 Hz	50 Hz	50 Hz	50 Hz
240 V Twist Lock	CB1,2			25A/5500W See Note 2	25A/5500W See Note 2					
240 V Duplex	CB1,2		15A/3600W See Note 2				15A/3600W			
240 V Duplex	CB3,4						15A/3600W			
230 V Single	CB1					15A/3600W			15A/3600W	15A/3600W
230 V Single	CB2					15A/3600W			15A/3600W	15A/3600W
230 V Single	CB1,2						15A/3600W			
230 V Single	CB3,4						15A/3600W			
120 V Twist Lock	CB1	30A/3500W								
120 V Duplex	CB1,3/ CB2,4				30A/3600W See Note 1					
120 V Duplex	CB2	20A/2400W								
120 V Duplex	CB3	20A/2400W	20A/2400W See Note 3	20A/2400W See Note 3						
120 V Duplex	CB4		20A/2400W See Note 3	20A/2400W See Note 3						
Total Power NOT to exceed		5500W	5500W	5500W	5500W	5000W	5000W	5000W	5000W	5000W

- Notes: 1. Each receptacle of the duplex can provide 15A/1800W. Do not parallel the two 120V duplex receptacles.
 2. Do not parallel the two 120V circuits.
 3. Do not parallel the two duplex outlets.

Calculating total power provided by generator.
 (See Generator Power Guidelines in Owner's Manual.)

Each receptacle can provide the watts or amps as shown above. However, the total power can not exceed 5500W.

The rating plate on electrical apparatus will contain the watts consumed or the rated input amps. Watts may be calculated by multiplying the rated voltage by the rated input amps.

$$\text{watts} = \text{volts} \times \text{amps}$$

For example, for the 495 218 Generator Power Panel,

120V, 3000W heater	3000W	
120V, 10A chain saw	1200W	
120V, 500W halogen lamp	500W	
Total	4700W	This loading is OK.

120V, 3000W heater	3000W	
120V, 10A chain saw	1200W	
120V, 5A router	600W	
120V, 1000W halogen lamp	1000W	
Total	5800W	This loading is <u>not</u> OK. It exceeds 5500W.

6-4. Wiring Instructions For Optional 120/240 Volt Twistlock Plug (NEMA L14-30P)



Tools Needed:

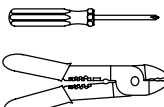

6

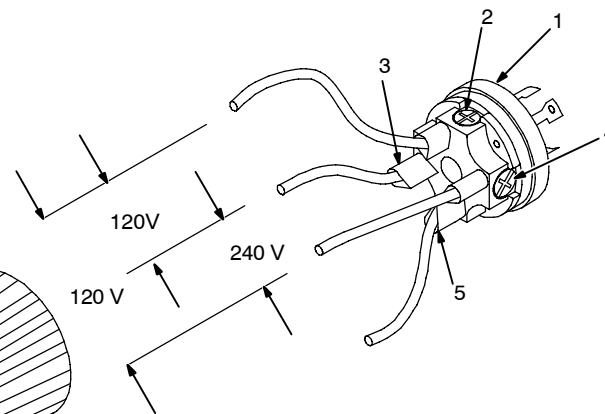

120V

240V

120V

- 1 Plug Wired For 120/240 V, 3-Wire Load
- 2 Neutral (Silver) Terminal
- 3 Load 1 (Brass) Terminal
- 4 Load 2 (Brass) Terminal
- 5 Ground (Green) Terminal
- 6 Cord Grip

When wired for 120 V loads, each duplex receptacle shares a load with one half of the 240 V receptacle.

Strip cord jacket back enough to separate conductors.

Strip conductors enough to make good contact with plug terminals. Make plug connections and reinstall outer shell and cord grip.

Tighten assembly screws onto shell. Do not overtighten.

plug3-11/99 - 802 527

SECTION 7 – MAINTENANCE

NOTE

Follow the storage procedure in the engine owner's manual if the unit will not be used for an extended period.

7-1. Maintenance Label

ENGINE MAINTENANCE

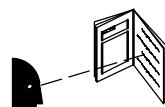

8 h

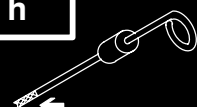

1.1 / (1.2 US qt,
1.94 Imp qt)



Unleaded
86 + Octane
6.5 / (1.7 US Gal,
11.4 Imp pt)

50 h

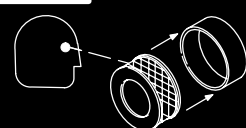

100 h



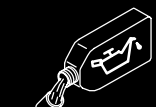

SG-SF/CC-CD

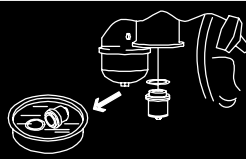

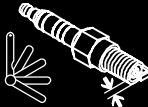

0.7 - 0.8 mm
(0.028 - 0.031 in)

200 h

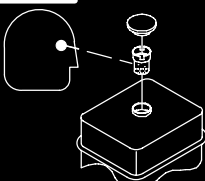

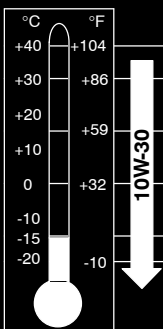

10W-30

Ref. S-175 679-A

7-2. Routine Maintenance

		<p>Recycle engine fluids.</p>		<p>▲ Stop engine before maintaining.</p> <p> See Engine Manual and Maintenance Label. Service more often if used in severe conditions.</p> <p>* To be done by Factory Authorized Service Agent.</p>	
8 h			20 h		
<p>Check fluid levels. See Section 4-4 or 4-5</p>		<p>Wipe up spills.</p>		<p>Check and clean spark arrestor screen. See engine manual.</p>	
50 h					
<p>Service air cleaner element. See engine manual.</p>		<p>Clean and tighten weld terminals.</p>			
100 h					
<p>Change oil. See engine manual and maintenance label.</p>		<p>Check spark plugs.</p>			
<p>Clean Fuel sediment cup.</p>		<p>Clean and tighten battery connections (Electric-Start models only).</p>			
200 h					
<p>Clean fuel tank and strainer.</p>		<p>Replace unreadable labels.</p>			
300 h					
<p>Check valve clearance.*</p>					
500 h					
<p>Repair or replace cracked cables.</p>		<p>Service welding generator brushes and slip rings. Service more often in dirty conditions.*</p>			
1000 h					
<p>Blow out or vacuum inside. During heavy service, clean monthly.</p>					

7-3. Overload Protection (Honda-Powered Units)

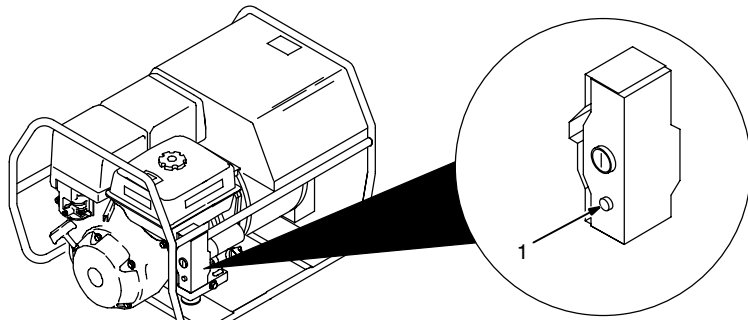

1 Ignition Circuit Breaker (Electric-Start Models Only)

The circuit breaker protects the engine battery charging circuit. A short circuit or a battery connected in reverse polarity will trip the circuit breaker.

Press button to reset breaker.

If breaker continues to open, check starter solenoid (see engine manual).

Ref. 802 094-A

7-4. Adjusting Engine Speed (Kohler-Powered Units)

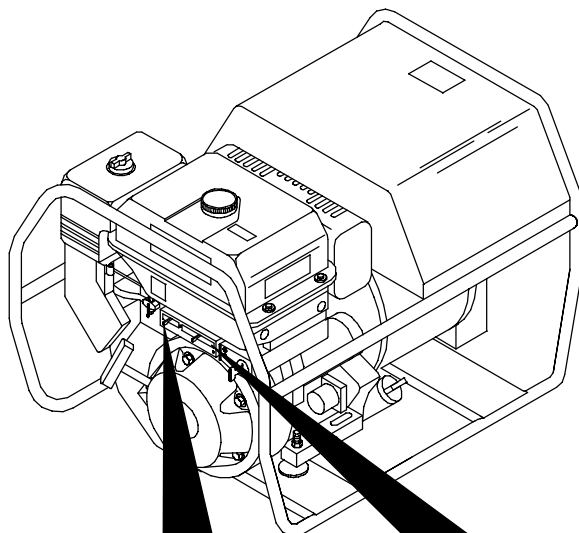
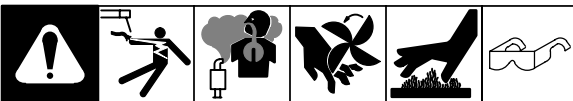

	2000 ± 150 rpm
	3720 ± 50 rpm (60 Hz) 3250 ± 50 rpm (50 Hz)

Tools Needed:



After tuning engine, check engine speeds. See table for proper no load speeds. If necessary, adjust speeds as follows:

Start engine and run until warm.

Weld/Power Speed Adjustment

- 1 Throttle Control Lever
- 2 Adjustment Screw

Move lever to Run (far right) position. To increase speed, turn screw out (counterclockwise) while lightly pushing lever to the right. To decrease speed, turn screw in (clockwise).

Idle Speed Adjustment

- 3 Adjustment Screw

Move lever to idle (far left) position. To increase idle speed, turn screw in (clockwise). To decrease idle speed, turn screw out (counterclockwise).

▲ Stop engine. Close fuel valve.

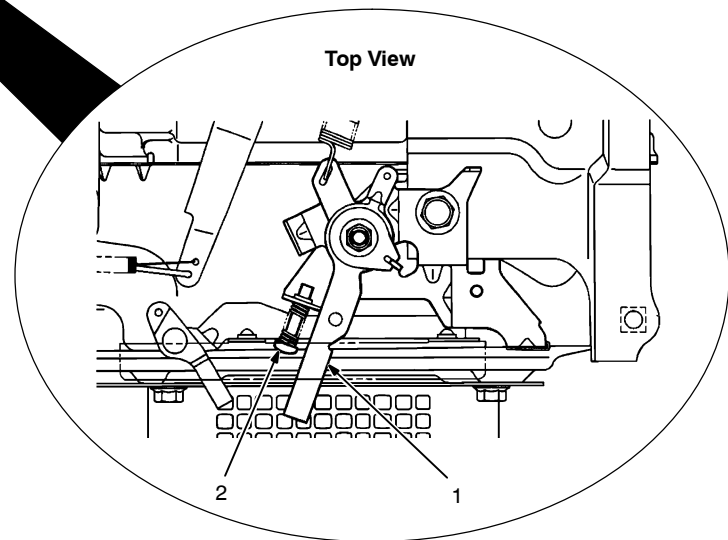
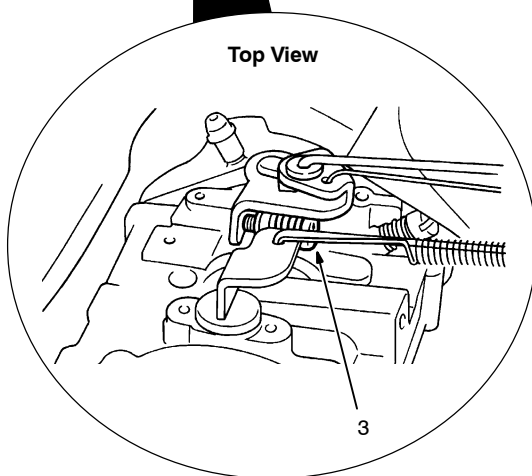

802 511-A / Kohler Dwg.

7-5. Adjusting Engine Speed (Honda-Powered Units)



	1400 ± 150 rpm
	3720 ± 50 rpm (60 Hz)
	3250 ± 50 rpm (50 Hz)

After tuning engine, check engine speeds. See table for proper no load speeds. If necessary, adjust speeds as follows:

Start engine and run until warm.

Weld/Power Speed Adjustment

- 1 Throttle Control Lever
- 2 Adjustment Screw

Move lever to Run (60 Hz) position. Turn screw and move lever until engine runs at weld/power speed.

Idle Speed Adjustment

- 3 Pilot Screw
- 4 Throttle Stop Screw

Move lever to idle position. Turn pilot screw until engine runs at highest idle speed. Turn stop screw until engine runs at rated idle speed (normally about 2-1/4 turns out.)

▲ **Stop engine. Close fuel valve.**

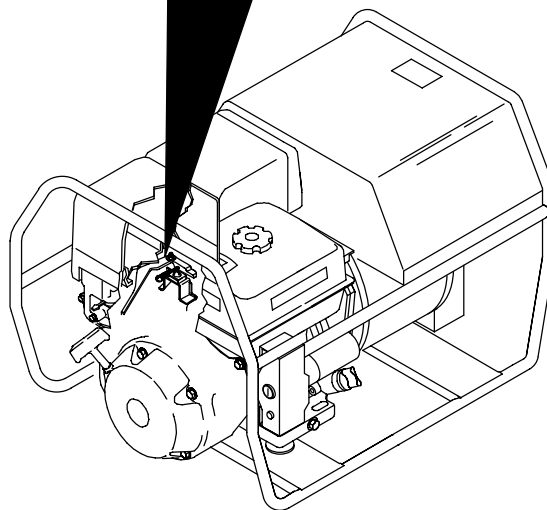
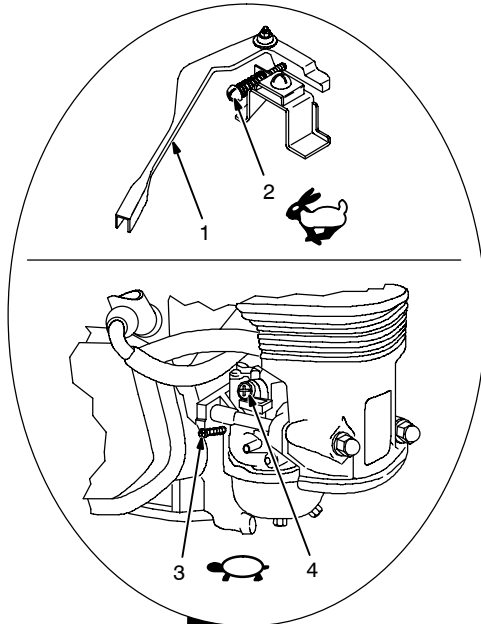

Tools Needed:

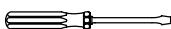

1/4, 3/8 in

802 097-A

SECTION 8 – THEORY OF OPERATION

1 Engine

Supplies force to turn revolving fields.

2 Revolving Field (Rotor)

Turns at 3700 rpm maximum (60 Hz) for weld and power. The speed and excitation current of the field coils determine voltages in stator windings.

3 Stator Windings

Supply power to exciter, generator power, and weld circuits.

4 Integrated Rectifier SR1

Changes ac output of stator windings to dc to supply excitation current to the exciter revolving field.

5 Control Board PC1

Adjusts weld output by changing revolving field current after comparing feedback to amperage setting of R1.

Uses current feedback signal for foldback circuit to prevent stator failure from short-circuit conditions.

Use voltage feedback signal to maintain open-circuit and generator power voltages regardless of Current Control R1 setting.

Monitors engine speed and stops weld and power output when speed drops below 2700 rpm.

6 Current Control R1

Changes output of stator weld windings by adjusting field current level in revolving field.

7 Generator Power Circuit Breakers

Protect ac receptacles from overload.

8 Generator Power AC Receptacles

Provide connection points and power for auxiliary equipment.

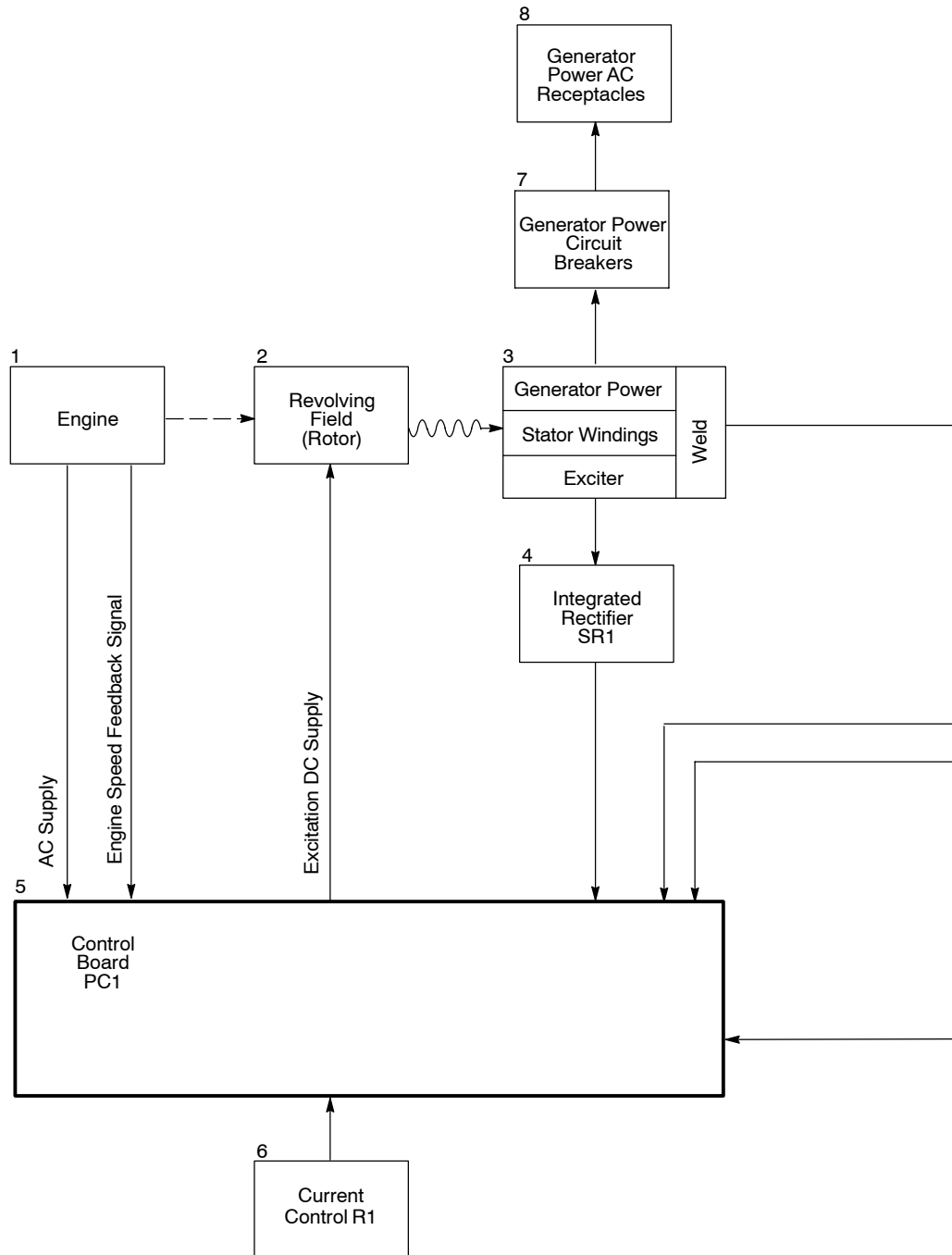

- 9 Main Rectifier SR2
Changes ac weld current to dc.
- 10 Suppressor VR1/R2
Protects SR2 from overload.
- 11 Stabilizer L1
Smooths weld output current.
- 12 Shunt
Provides weld current feedback to control board PC1.
- 13 HF Filter Board PC2
Protects unit from high frequency.
- 14 Positive (+) And Negative (-)
Weld Output Terminals
Provide weld output.

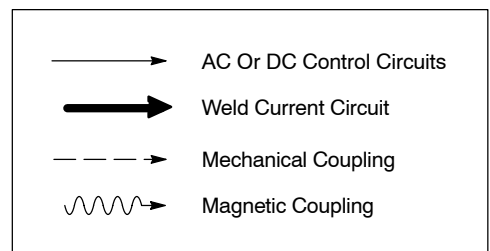
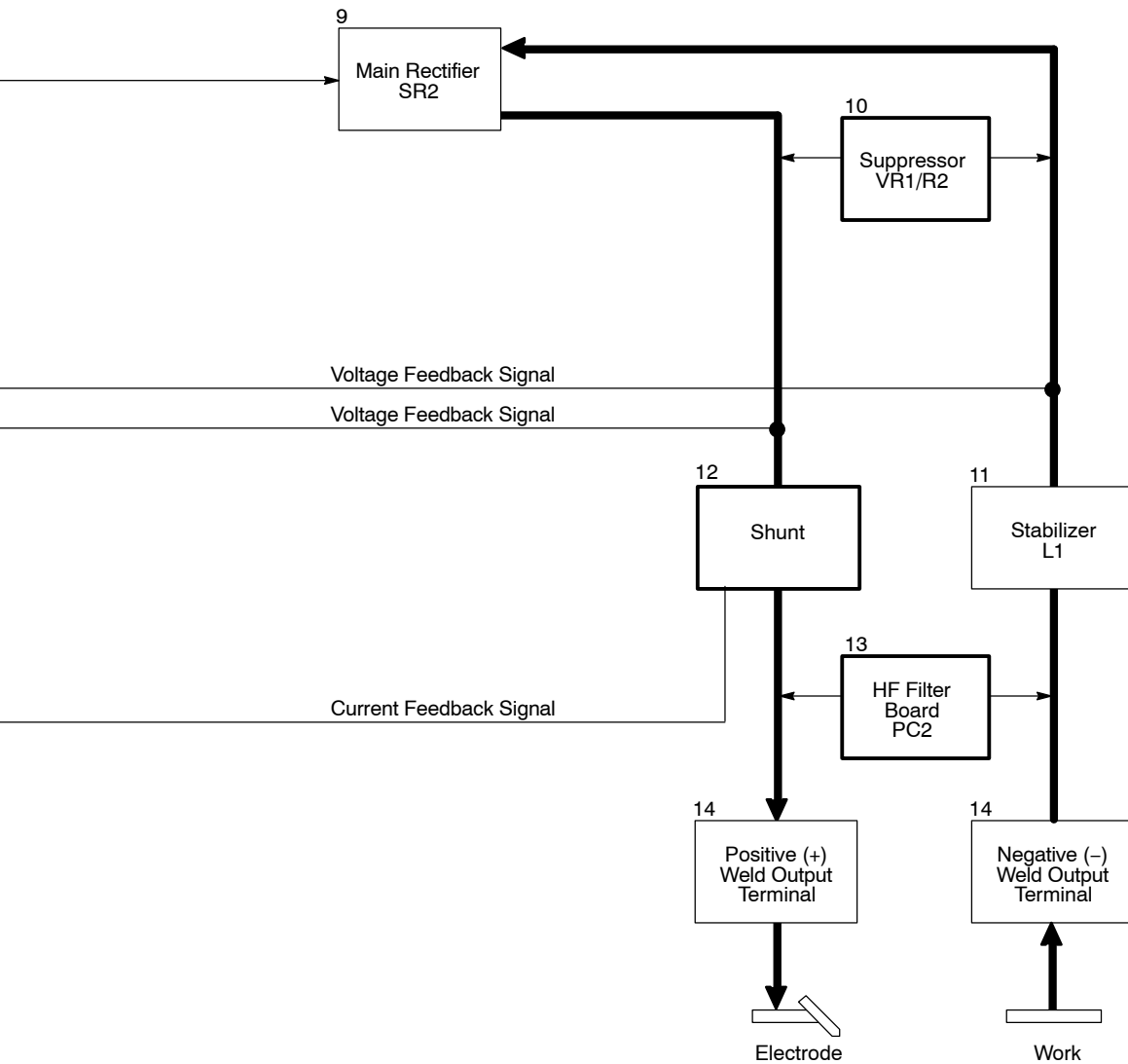

SECTION 9 – EXPLANATION OF ELECTRICAL PARTS

elect_parts 7/04



9-1. Safety Precautions – Read Before Using This Guide





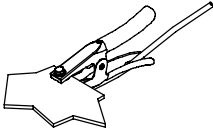
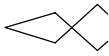
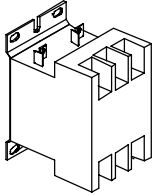
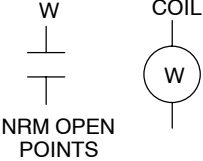
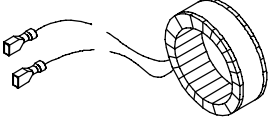
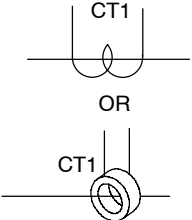
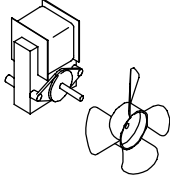
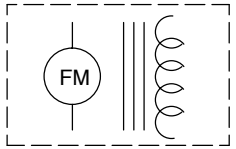
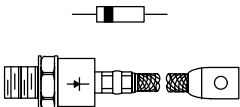
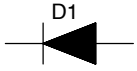
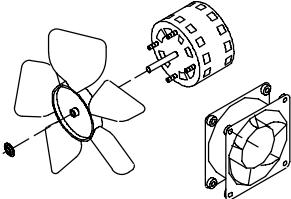

▲ WARNING: ELECTRIC SHOCK can kill.

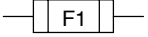
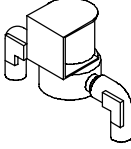
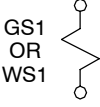
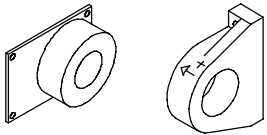
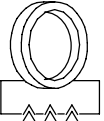

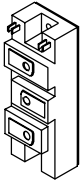
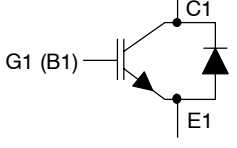
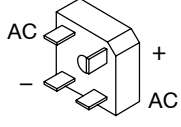
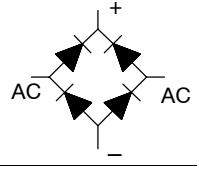
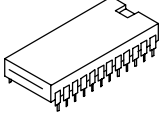
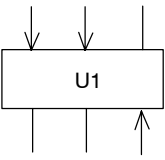
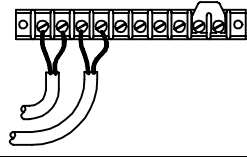
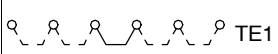
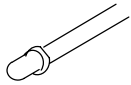
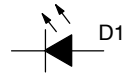
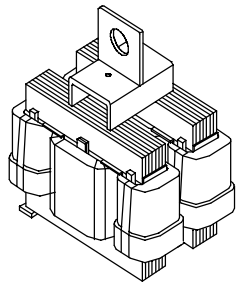
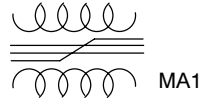
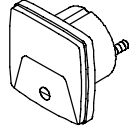
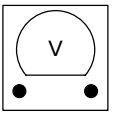
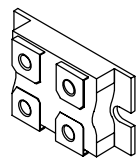
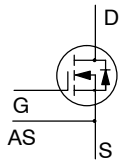

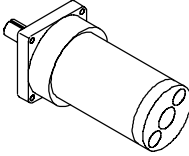
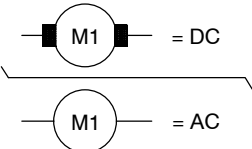
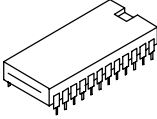
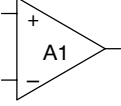
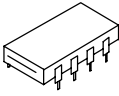
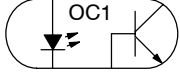

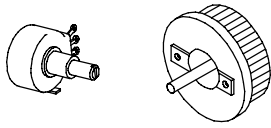
- Disconnect input power or stop engine before servicing.
- Do not touch live electrical parts.
- Do not operate machines with covers removed.
- Have only qualified persons install, use, or service equipment.

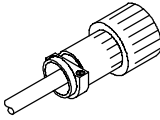
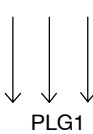
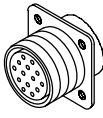
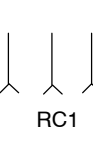
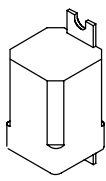
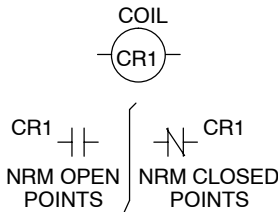
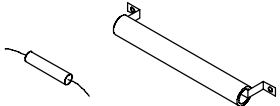
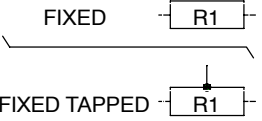
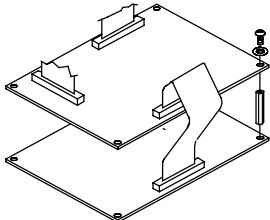
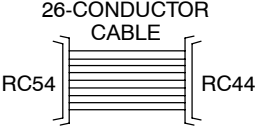

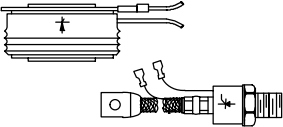
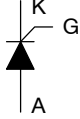
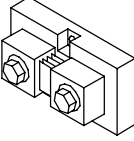
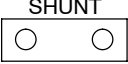
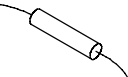
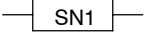
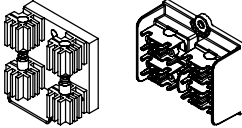
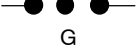
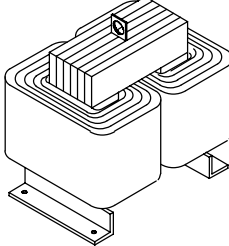
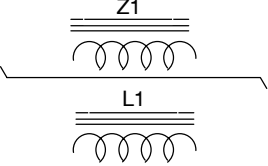

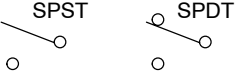
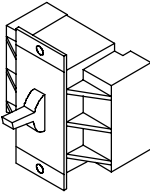
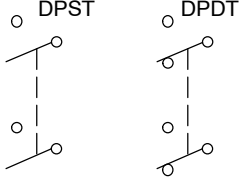
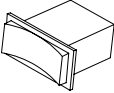

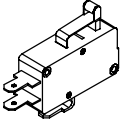
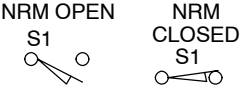

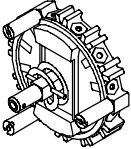
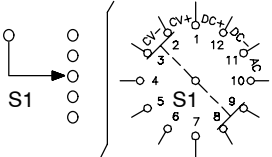

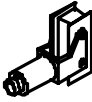





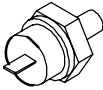



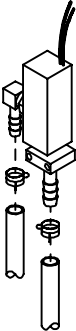

PART NAME	FUNCTION	PICTURE	CIRCUIT SYMBOL
BATTERY	A source of DC voltage. Typically used in Engine Driven equipment.		
BRUSHES/SLIP RINGS	Components that allow electrical connections between stationary and rotating contacts.		
CAPACITOR	A device that stores electrical energy. Large capacitors or a "bank" of capacitors can be used to "smooth out" the DC welding arc in a MIG welding power source. Smaller "disk" capacitors can be used for HF protection.		
CHASSIS	The green ground wire of a primary cord is connected to the machine frame (chassis) for safety. Also, you may find many "HF bypass" capacitors connected to chassis to reduce High Frequency interference. Expect to see this symbol used numerous times in circuit diagrams. The picture shown here is from an Engine Drive where several wires including the battery are connected to the chassis.		
CIRCUIT BREAKER	A protection device that breaks a circuit when current levels exceed its rating. Unlike a fuse that needs to be replaced when blown, a circuit breaker can be reset.		
CIRCUIT COMMON	When many wires are connected together, rather than showing all the "lines" and "dots", this symbol may appear on the circuit. Look for other Circuit Common symbols on a circuit diagram. For instance, say 10 symbols are found on a circuit, this means all ten points are electrically tied together.		

PART NAME	FUNCTION	PICTURE	CIRCUIT SYMBOL
CLAMP	A spring-loaded connection device. A good example would be the "work clamp" used to connect the weld cable from a power source to the workpiece that will be welded.		
CONTACTOR	A heavy duty relay. Usually used to make and break the welding arc or primary power.		 NRM OPEN POINTS
CURRENT TRANSFORMER	A transformer that produces an AC voltage used for measuring purposes. The primary winding is in series with the circuit carrying the current to be measured. Its main use in engine-driven equipment is to activate the "Automatic Idle" circuit by sensing welding current or auxiliary power current.		 OR
DASHED LINE	A dashed line between parts means there is a mechanical connection between these parts. When a dashed line boxes in parts, this means the parts make up an option or are combined into one part. In all cases, dashed lines do not conduct electricity. The picture shown is a combination fan motor and transformer in one part.		
DIODE	A device that allows current to flow in one direction only. Most common use is to change AC to DC.		
FAN MOTOR	This device provides cooling of the internal parts of a welding power source.		
FUSE	A protection device, usually an enclosed piece of wire that melts and breaks the circuit when the current exceeds the fuse rating.		
GAS OR WATER SOLENOID (VALVE)	These are electromechanical devices used to start or stop the flow of shielding gas or water.		
HALL DEVICE	Produces a small DC voltage proportional to the current it is sensing (usually welding current). This feedback signal can be used to regulate the welding output (line voltage compensation). It may even be used to drive an ammeter.		

PART NAME	FUNCTION	PICTURE	CIRCUIT SYMBOL
IGBT	A device that is used as an “electronic switch”. When a signal is applied to the gate (G), current is allowed to flow from the emitter (E) to the collector (C). This device is typically used in “Inverter” designed welding machines to control the welding output.		
INTEGRATED BRIDGE RECTIFIER	An arrangement of four diodes used to change AC to DC.		
INTEGRATED CIRCUIT	IC's often called “chips” provide a complete circuit function with inputs and outputs. A good example would be the “Pulse Width Modulation” chip used in many wire feeder designs.		
JUMPER LINK	Usually, the jumper link is a piece of brass that connects two terminals together. Dashed lines indicate possible locations for other jumper links.		
LIGHT EMITTING DIODE	This device usually referred to by its initials LED is used to tell you when a particular circuit is activated. This function is very helpful for troubleshooting.		
MAGNETIC AMPLIFIER	This device usually referred to as a “Mag-Amp” is made up of coil windings and an iron core similar to a transformer. It controls a large welding current by varying a small “control current”.		
METER	A measuring device. A “voltmeter” is a good example.		 V = voltmeter A = ammeter HM = hour meter
MOSFET	A device that is used as an “electronic switch”. When a signal is applied to the gate (G), current is allowed to flow from the source (S) to the drain (D). This device can be used to control a relay, the speed of a motor, or even the output of a welding machine.		

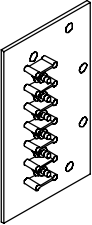
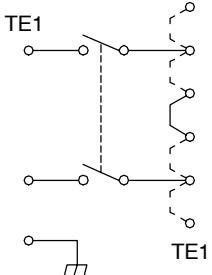
PART NAME	FUNCTION	PICTURE	CIRCUIT SYMBOL
MOTOR	A device that converts electrical energy into mechanical energy. Typically used to feed wire in a MIG welding system, or pump coolant in a recirculating liquid-cooling system.		 = DC = AC
OPERATIONAL AMPLIFIER	Usually referred to as an "Op-Amp", this IC chip is very versatile and widely used on PC boards. A typical use might be as a "comparator", comparing the command signal to the feedback signal allowing the welding output to be kept constant.		
OPTICAL COUPLER	A device that uses "light" to get electrical separation (isolation). This eliminates noise that might be in one circuit from affecting another circuit.		
PILOT LIGHT	A light located on the front panel which indicates if the machine is on or off.		
POTENTIOMETER OR RHEOSTAT	Both devices have a moveable brush that makes contact along a resistor, allowing you to easily change the resistance measured at the brush (sometimes referred to as a wiper). Their primary purpose is to give the operator a way to adjust welding parameters such as wire speed, preflow time, voltage, inductance, etc.		 CW = CLOCKWISE → CCW = COUNTER-CLOCKWISE ←
PLUG	A connection device that hangs loose with wires coming out the back of it. Please note that the plug terminals can be either male or female.		 → MALE ← FEMALE PLG = LOOSE
RECEPTACLE	A connection device that is mounted or fixed. Just like a plug, the terminals can be either male or female.		 → MALE ← FEMALE RC = MOUNTED
RELAY--COIL AND CONTACTS, NORMALLY OPEN AND NORMALLY CLOSED	This is an electromechanical device whose contacts change state (the normally open points close and the normally closed points open) when proper voltage is applied to the coil. These contact points in turn may control a fan motor, gas solenoid, contactor, etc. Circuit diagrams (schematics) always show the contact points in the power off state.		 COIL CR1 CR1 NRM OPEN POINTS NRM CLOSED POINTS
RESISTOR	A device which resists the flow of electric current. Uses include limiting the current for a motor brake circuit in a wire feeder and for discharging a capacitor.		 FIXED R1 FIXED TAPPED R1
RIBBON CABLE	A connection device where the wires are laid out flat. Usually to connect circuits from one PC board to another PC board.		 26-CONDUCTOR CABLE RC54 RC44

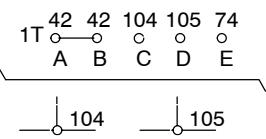
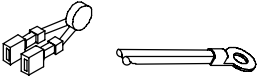
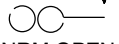
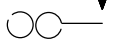
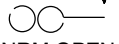
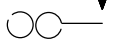
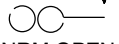
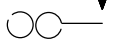
PART NAME	FUNCTION	PICTURE	CIRCUIT SYMBOL
SCR	A Silicon Controlled Rectifier (SCR) is an electrical device with three connections, anode, cathode, and gate. It will allow current to flow in only one direction and will only do so after receiving a signal on the gate lead. SCR's are used to change AC to DC and to control the output to a load such as a welding arc.		
SHUNT	A precision low-value resistor typically used to supply a small voltage to drive an ammeter.		
SNUBBER	A device used to absorb voltage spikes, sometimes found connected across the points of a relay.		
SPARK GAP	The arrangement of two electrodes between which a discharge of electricity will occur. Typically used to produce "high frequency" which can be used for arc starting when TIG welding.		
STABILIZER/ REACTOR	When placed in a DC circuit, the inductor or stabilizer as it is usually called, will oppose any change in existing current. It is therefore widely used to "stabilize" the welding arc. When the inductor is placed in an AC circuit it is referred to as a reactor where it now acts to restrict the flow of current. A "tapped reactor" is used to create current ranges for welding.		
SWITCH	A mechanical device that completes or breaks the path of the current or sends it over a different path.		
	A multi-pole switch will use dashed lines to connect poles. SPST = <u>S</u> ingle <u>P</u> ole <u>S</u> ingle <u>T</u> hrow SPDT = <u>S</u> ingle <u>P</u> ole <u>D</u> ouble <u>T</u> hrow DPST = <u>D</u> ouble <u>P</u> ole <u>S</u> ingle <u>T</u> hrow DPDT = <u>D</u> ouble <u>P</u> ole <u>D</u> ouble <u>T</u> hrow		
MOMENTARY SWITCH	A switch that "springs back" to its original position.		
LIMIT SWITCH	A switch mounted in the path of a moving object and actuated by its passage.		
PUSH BUTTON SWITCH	A switch in which a button must be depressed each time the contacts are to be opened or closed.		
ROTARY SWITCH	A switch in which its shaft must be rotated to actuate the contacts.		

PART NAME	FUNCTION	PICTURE	CIRCUIT SYMBOL																														
PRESSURE SWITCH	A change in the pressure of a gas or liquid will actuate this switch.		<table border="0"> <tr> <td>OPENS ON INCREASE</td> <td>CLOSES ON INCREASE</td> </tr> <tr> <td></td> <td></td> </tr> </table>	OPENS ON INCREASE	CLOSES ON INCREASE																												
OPENS ON INCREASE	CLOSES ON INCREASE																																
																																	
TEMPERATURE SWITCH	Typically used to protect engines, this switch is actuated by heat.		<table border="0"> <tr> <td>OPENS ON INCREASE</td> <td>CLOSES ON INCREASE</td> </tr> <tr> <td></td> <td></td> </tr> </table>	OPENS ON INCREASE	CLOSES ON INCREASE																												
OPENS ON INCREASE	CLOSES ON INCREASE																																
																																	
WATER FLOW SWITCH	A switch that is actuated by the flow of a liquid. Typically used to protect "water-cooled" torches.		<table border="0"> <tr> <td>OPENS ON INCREASE</td> <td>CLOSES ON INCREASE</td> </tr> <tr> <td></td> <td></td> </tr> </table>	OPENS ON INCREASE	CLOSES ON INCREASE																												
OPENS ON INCREASE	CLOSES ON INCREASE																																
																																	
TERMINAL ASSEMBLY	A connection point for primary power and the jumper links that are used to match the input voltage to the machine. Usually, the terminal assembly is marked with the letters "TE", but the electrical symbol looks identical to a standard terminal strip.																																
TERMINAL STRIP	An insulated connection point for wires. They are used for the ease of making multiple connections and can be a convenient point for making electrical checks when troubleshooting. (Notice the "jumper link" connecting terminals A and B together.)		<table border="0"> <tr> <td>42</td> <td>42</td> <td>104</td> <td>105</td> <td>74</td> </tr> <tr> <td>1T</td> <td>○</td> <td>○</td> <td>○</td> <td>○</td> </tr> <tr> <td></td> <td>A</td> <td>B</td> <td>C</td> <td>D</td> </tr> <tr> <td colspan="5">└──────────┘ └──────────┘</td> </tr> <tr> <td></td> <td>○</td> <td>○</td> <td></td> <td></td> </tr> <tr> <td></td> <td>104</td> <td>105</td> <td></td> <td></td> </tr> </table>	42	42	104	105	74	1T	○	○	○	○		A	B	C	D	└──────────┘ └──────────┘						○	○				104	105		
42	42	104	105	74																													
1T	○	○	○	○																													
	A	B	C	D																													
└──────────┘ └──────────┘																																	
	○	○																															
	104	105																															
THERMISTOR	A thermally sensitive resistor. There are two types of thermistor, PTC (Positive Temperature Coefficient) and NTC (Negative Temperature Coefficient). A PTC thermistor's resistance will increase as the temperature goes up, where as an NTC thermistor's resistance will decrease as the temperature goes up. Primarily used for "Fan on Demand" and "Thermal Shutdown" circuits.		<table border="0"> <tr> <td>—</td> <td>RT1</td> <td>—</td> </tr> <tr> <td></td> <td>OR</td> <td></td> </tr> <tr> <td>—</td> <td>TH1</td> <td>—</td> </tr> </table>	—	RT1	—		OR		—	TH1	—																					
—	RT1	—																															
	OR																																
—	TH1	—																															
THERMOSTAT, NORMALLY OPEN AND NORMALLY CLOSED	This is a switch that closes its normally open contacts (or opens its normally closed contacts) when a preset temperature is reached. When the temperature goes back down, it will reset itself. Uses of these devices include turning on a fan motor when needed and shutting off the output of a welding power source if it is overheating.		<table border="0"> <tr> <td>TP1</td> <td>TP1</td> </tr> <tr> <td></td> <td></td> </tr> <tr> <td>NRM OPEN</td> <td>NRM CLOSED</td> </tr> </table>	TP1	TP1			NRM OPEN	NRM CLOSED																								
TP1	TP1																																
																																	
NRM OPEN	NRM CLOSED																																
TRANSISTOR	Most commonly used as an electronic switch. There are two basic types, PNP and NPN. This refers to their internal design, which determines current flow direction.		<table border="0"> <tr> <td>Q1</td> <td>C</td> <td>Q1</td> <td>C</td> </tr> <tr> <td>B</td> <td>E</td> <td>B</td> <td>E</td> </tr> <tr> <td>NPN</td> <td></td> <td>PNP</td> <td></td> </tr> </table>	Q1	C	Q1	C	B	E	B	E	NPN		PNP																			
Q1	C	Q1	C																														
B	E	B	E																														
NPN		PNP																															

PART NAME	FUNCTION	PICTURE	CIRCUIT SYMBOL
TRANSFORMER	A device that changes AC voltage from one magnitude to another. Typically used to reduce high primary voltages to lower welding voltages.		
TRIAC	An electronic AC switch. It is turned on by a gate signal similar to an SCR.		
TWISTED WIRE	Wires are twisted to prevent “electrical noise” from interfering with the circuit. A good example is the red and white gate leads going to an SCR. Typically, these wires are twisted together to help prevent the SCR from misfiring.		
VARISTOR	A protection device whose resistance is dependent on the voltage applied to it. In normal operation it has a high resistance; however, a surge of voltage (voltage spike) will cause its resistance to go way down and absorb the spike. These devices are most often found in rectifying circuits, where they are used to protect the diodes.		
WIRES WITH CONNECTION	When lines (wires) cross on a circuit diagram and there is a “black dot”, this means that the two wires are electrically connected together. The method of connection (bolted, friction lugs, etc.) is not indicated with this symbol. However, a “white dot” indicates that the method of connection is a terminal strip. Of course, no dot means no connection.		

SECTION 10 – TROUBLESHOOTING

10-1. Troubleshooting Tables

A. Welding

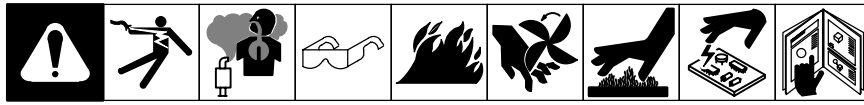

☞ See Section 10-2 for test points and values and Section 13 and following for parts location.

Trouble	Remedy
No weld output.	Check weld connections.
	Disconnect equipment from receptacles when starting unit.
	Check resistance and connections of resistor R3; R3 is 20 ohms $\pm 5\%$. Replace R3 if necessary.
	Check engine speed, and adjust if necessary (see Section 7-4 or 7-5). Output stops if engine speed is too low.
	Check slip rings, and install new brushes if necessary (see Section 10-7).
	Check resistance and connections of Current Control R1; R1 is 0 to 1000 ohms $\pm 10\%$. Replace R1 if necessary.
	Check control board PC1 and connections, and replace if necessary (see Section 10-5). PC1 LED lights when board is energized.
	Check engine lamp coil and connections, and replace coil if necessary. Lamp coil supplies power to control board PC1. PC1 LED lights when board is energized (see Section 10-5).
	Check capacitor C1 for a short or open, and replace if necessary. If C1 is open, also replace circuit board PC1.
	Check integrated rectifier SR1, and replace if necessary.
	Check diodes in main rectifier SR2, and replace if open.
	Disconnect stator weld leads from main rectifier SR2, and check continuity between stator weld leads. Replace stator if necessary.
	Low weld output.
Check throttle lever setting.	
Check weld cable size and length.	
Check engine speed, and adjust if necessary (see Section 7-4 or 7-5).	
Service air cleaner according to engine manual.	
Check slip rings, and install new brushes if necessary (see Section 10-7).	
Check control board PC1 and connections, and replace if necessary (see Section 10-5). PC1 LED lights when board is energized.	
Check capacitor C1 for a short or open, and replace if necessary. If C1 is open, also replace circuit board PC1.	
Check integrated rectifier SR1, and replace if necessary.	
Check diodes in main rectifier SR2, and replace if open.	
Disconnect stator weld leads from main rectifier SR2, and check continuity between stator weld leads. Replace stator if necessary.	
Disconnect leads 3 and 4 from brushes, and check continuity across slip rings. Replace rotor if necessary.	
Disconnect stator exciter leads (black) from integrated rectifier SR1, and check continuity between exciter leads. Replace stator if necessary.	

Trouble	Remedy
High weld output.	Check Current Control R1 setting.
	Check engine speed, and adjust if necessary (see Section 7-4 or 7-5).
	Check resistance and connections of suppressor VR1/R2. R2 is 1000 ohms $\pm 5\%$. Replace VR1/R2 if necessary.
	Check slip rings, and install new brushes if necessary (see Section 10-7).
	Check control board PC1 and connections, and replace if necessary (see Section 10-5). Replace PC1 if shorted across receptacle RC4 pins 4 and 6. PC1 LED lights when board is energized.
	Check capacitor C1 replace if open. If C1 is open, also replace circuit board PC1.
	Check diodes in main rectifier SR2, and replace if shorted.
Erratic weld output.	Check Current Control R1 setting.
	Tighten and clean connections to electrode and workpiece.
	Tighten and clean connections inside and outside welding generator.
	Use dry, properly-stored electrodes for SMAW.
	Check engine speed, and adjust if necessary (see Section 7-4 or 7-5).
	Check throttle/governor linkage for smooth, non-binding operation.
	Check slip rings, and install new brushes if necessary.
	Check control board PC1 and connections, and replace if necessary. PC1 LED lights when board is energized.
	Check capacitor C1 for a short or open, and replace if necessary. If C1 is open, also replace circuit board PC1.
	Check integrated rectifier SR1, and replace if necessary.
	Check diodes in main rectifier SR2, and replace if open.
	Check stabilizer L1 for signs of winding failure. Check continuity across windings, and check for proper connections. Replace L1 if necessary.
	Disconnect leads 3 and 4 from brushes, and check continuity across slip rings. Replace rotor if necessary.

B. Generator Power

Trouble	Remedy
No output at ac receptacles.	Reset circuit breakers (see Section 6-1).
	Check connections to control board PC1.
	Check receptacle wiring and connections.
	Check resistance and connections of resistor R3; R3 is 20 ohms $\pm 5\%$. Replace R3 if necessary.
	Check engine speed, and adjust if necessary (see Section 7-4 or 7-5). Output stops if engine speed is too low.
	Check slip rings, and install new brushes if necessary (see Section 10-7).
	Check control board PC1 and connections, and replace if necessary (see Section 10-5). PC1 LED lights when board is energized.
	Check engine lamp coil and connections, and replace coil if necessary. Lamp coil supplies power to control board PC1. PC1 LED lights when board is energized.
	Check capacitor C1 for a short or open, and replace if necessary. If C1 is open, also replace circuit board PC1.
	Check integrated rectifier SR1, and replace if necessary.
	Check diodes in main rectifier SR2, and replace if open.
	Disconnect stator generator power leads from connection block 1T, and check continuity between generator power leads 1 and 3, and leads 2 and 4. Replace stator if necessary.

Trouble	Remedy
	Disconnect leads 3 and 4 from brushes, and check continuity across slip rings. Replace rotor if necessary.
	Disconnect stator exciter leads (black) from integrated rectifier SR1, and check continuity between exciter leads. Replace stator if necessary.
High power output at ac receptacles.	Check engine speed, and adjust if necessary (see Section 7-4 or 7-5).
	Move throttle lever to Run (use 50 Hz position for 50 Hz equipment).
	Check control board PC1 and connections, and replace if necessary (see Section 10-5). Replace PC1 if shorted across receptacle RC4 pins 4 and 6. PC1 LED lights when board is energized.
	Check capacitor C1 for a short or open, and replace if necessary. If C1 is open, also replace circuit board PC1.
	Disconnect leads 3 and 4 from brushes, and check continuity across slip rings. Replace rotor if necessary.
Low power output at ac receptacles.	Move throttle lever to Run (use 60 Hz position for 60 Hz equipment).
	Check engine speed, and adjust if necessary (see Section 7-4 or 7-5).
	Check capacitor C1 for a short or open, and replace if necessary. If C1 is open, also replace circuit board PC1.
	Check integrated rectifier SR1, and replace if necessary.
	Disconnect leads 3 and 4 from brushes, and check continuity across slip rings. Replace rotor if necessary.
Erratic power output at ac receptacles.	Check fuel level.
	Check receptacle wiring and connections.
	Check throttle/governor linkage for smooth, non-binding operation.
	Service air cleaner according to engine manual.
	Check engine speed, and adjust if necessary (see Section 7-4 or 7-5).
	Check slip rings, and install new brushes if necessary (see Section 10-7).
	Check control board PC1 and connections, and replace if necessary. PC1 LED lights when board is energized.

C. Engine

Trouble	Remedy
Engine will not crank (electric-start models only).	Reset ignition circuit breaker.
	Check battery voltage.
	Check battery connections and tighten if necessary.
	Check engine ignition circuit, and replace components if necessary.
Engine will not start.	Check fuel level (see Section 4-4 or 4-5).
	Open fuel valve (see Section 4-4 or 4-5). Close fuel valve before moving unit or carburetor may flood and make starting difficult.
	Check battery voltage (electric-start models only).
	Check battery connections and tighten if necessary (electric-start models only).
	Check oil level (see Section 4-4 or 4-5). Engine stops if oil level is too low. Refill crankcase with proper viscosity oil for operating temperature.
	Check low oil level shutdown switch, and replace if necessary.

Trouble	Remedy
Engine stopped during normal operation.	Check fuel level (see Section 4-4 or 4-5).
	Open fuel valve (see Section 4-4 or 4-5). Close fuel valve before moving unit or carburetor may flood and make starting difficult.
	Check oil level (see Section 4-4 or 4-5). Engine stops if oil level is too low.
	Check low oil level shutdown switch, and replace if necessary.
	Check unit operating angle. Low oil level shutdown switch may stop engine if unit is tilted.
Battery discharges between uses (electric-start models only).	Clean battery, terminals, and posts with baking soda and water solution; rinse with clear water.
	Periodically recharge battery (approximately every 3 months).
	Replace battery.
	Check voltage regulator and connections according to engine manual.
Unstable or sluggish engine speeds.	Check engine speed, and adjust if necessary (see Section 7-4 or 7-5).
	Check throttle/governor linkage for smooth, non-binding operation.
	Tune-up engine according to engine manual.

10-2. Troubleshooting Circuit Diagram For Welding Generator (Use With Section 10-3)

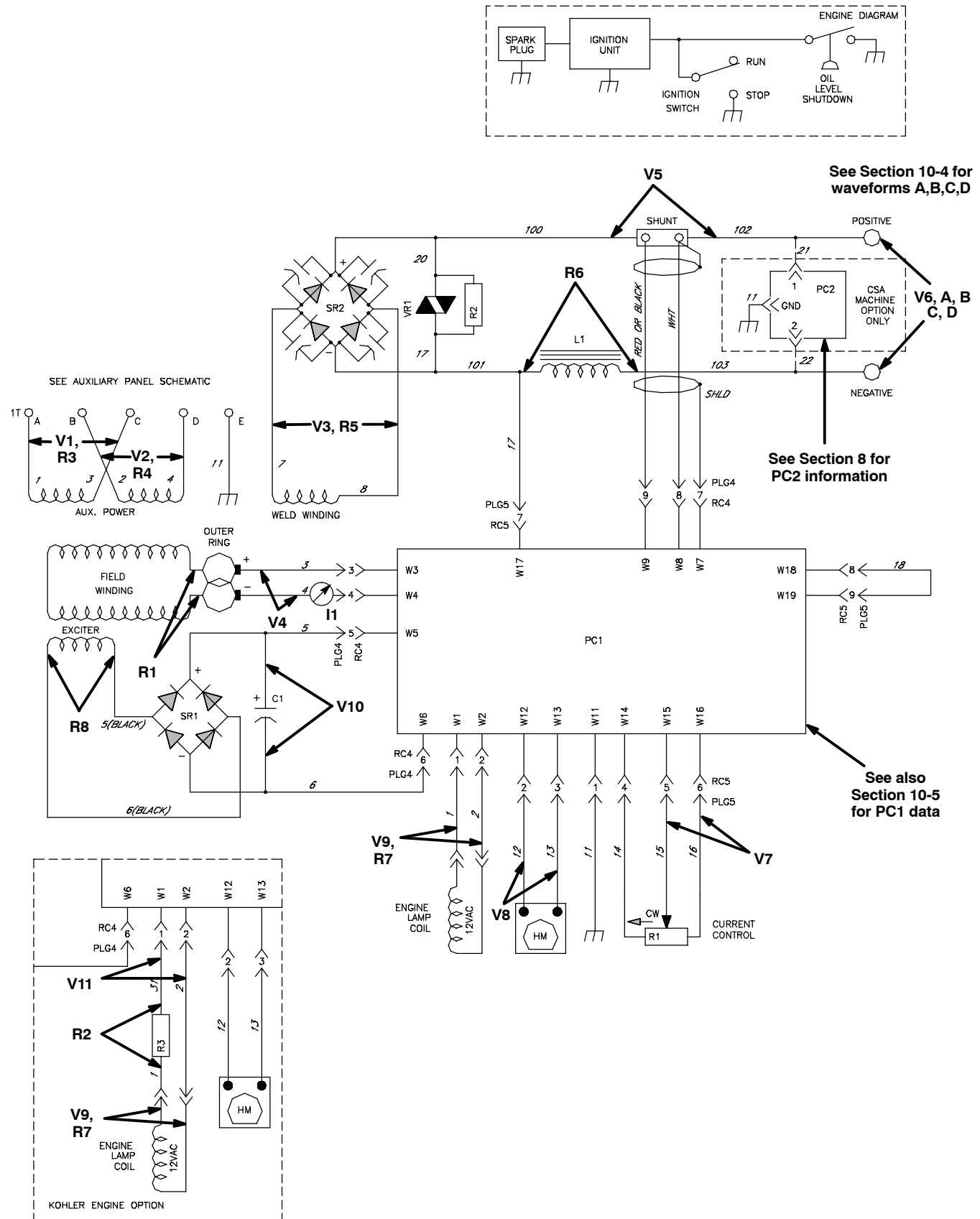

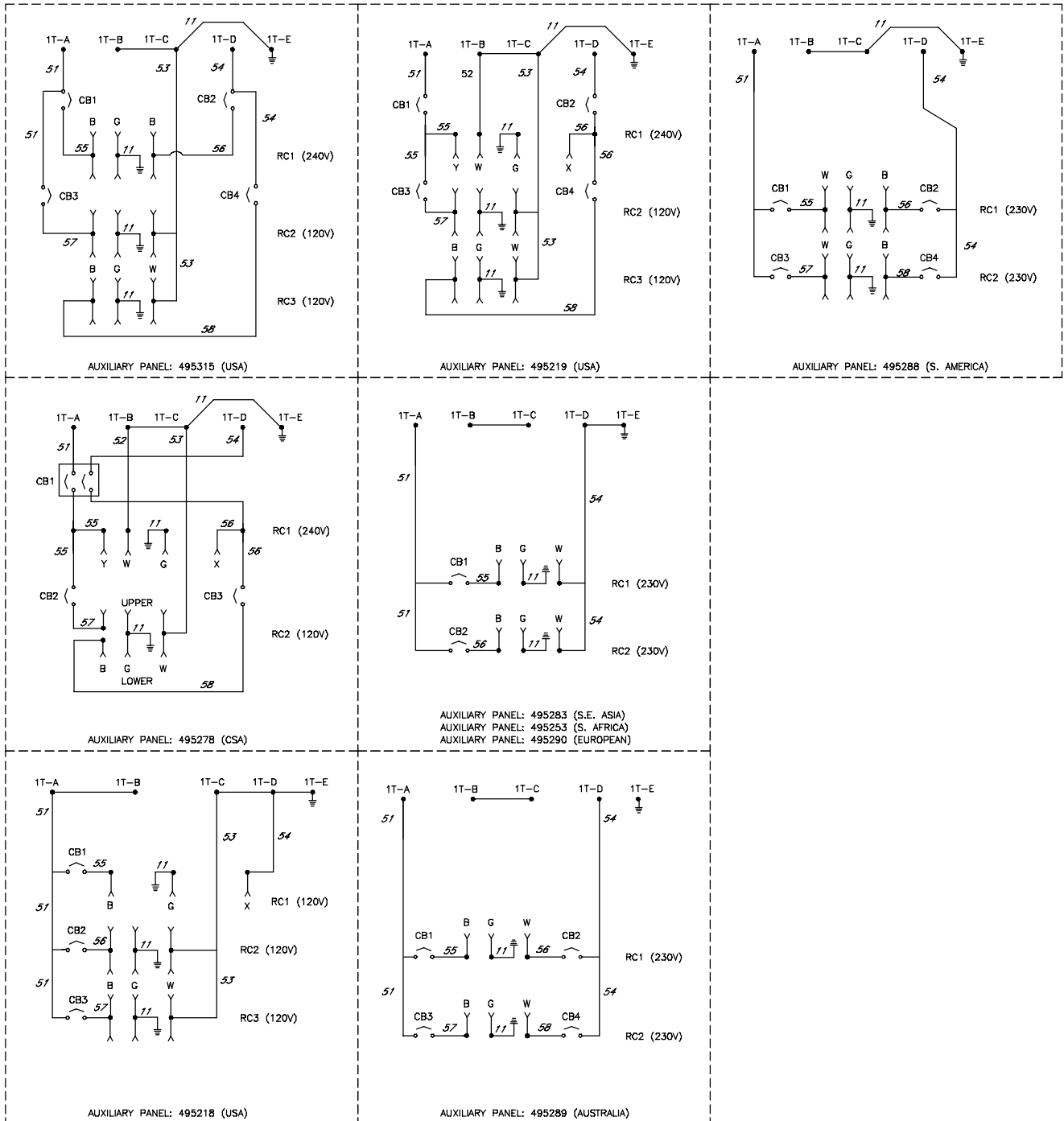

10-3. Test Points And Values (Use With Section 10-2)

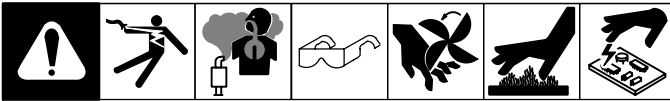

Voltage Readings	
a) Tolerance – $\pm 10\%$ unless specified	
b) Condition – 70°F (21°C); cold machine (no warm-up); no load	
c) Weld/power rpm unless specified	
d) Reference – single arrow: reference to circuit common (lead 11); double arrow: reference to points indicated	
e) Wiring Diagram – see Section 12	
V1	122 volts ac $\pm 5\%$ (60 Hz) 110 volts ac $\pm 5\%$ (50 Hz)
V2	122 volts ac $\pm 5\%$ (60 Hz) 110 volts ac $\pm 5\%$ (50 Hz)
V3	76 volts ac (60 Hz) 69 volts ac (50 Hz)
V4	50 volts dc (60 Hz) 70 volts dc (50 Hz)
V5	At 25 volt, 100 ampere weld load: Less than 1 volt dc (60 and 50 Hz)
V6	68 volts dc (60 Hz) 62 volts dc (50 Hz)
V7	0 – 10 volts dc (60 or 50 Hz)
V8	15 volts dc (60 or 50 Hz)
V9	23.5 volts ac (60 Hz) 20.5 volts ac (50 Hz)
V10	200 volts dc (60 Hz) 176 volts dc (50 Hz)
V11	18.2 volts ac (60 Hz) – Kohler Only 15.5 volts ac (50 Hz) – Kohler Only

Amperage Readings	
a) Tolerance – $\pm 5\%$ unless specified	
b) Condition – 70°F (21°C); cold machine (no warm-up); no load	
I1	1.8 amps dc (60 Hz) 2.3 amps dc (50 Hz)

Resistance Values	
a) Tolerance – $\pm 10\%$ unless specified	
b) Condition – 70°F (21°C); cold machine (no warm-up)	
c) Wiring Diagram – see Section 12	
d) Stop engine before checking resistance	
R1	27 ohms
R2	20 ohms (Kohler Only)
R3 thru R8	Less than 1 ohm

Test Equipment Needed:

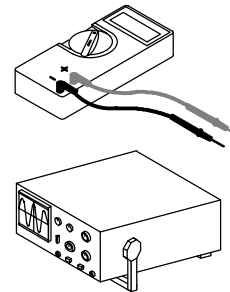

10-4. Waveforms For Section 10-2



Waveforms shown are for 60 Hertz models;
waveforms for 50 Hertz models are similar.

5 ms 50 V

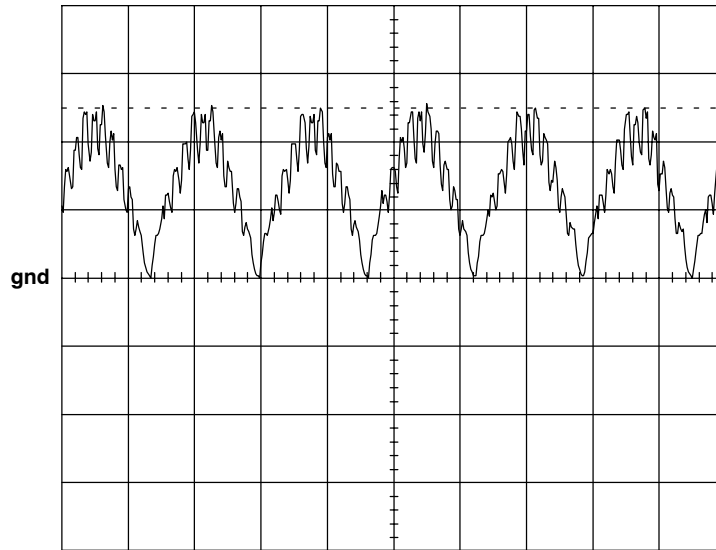

A. DC/CC Open-Circuit Voltage, No Load, 60 Hz

5 ms 20 V

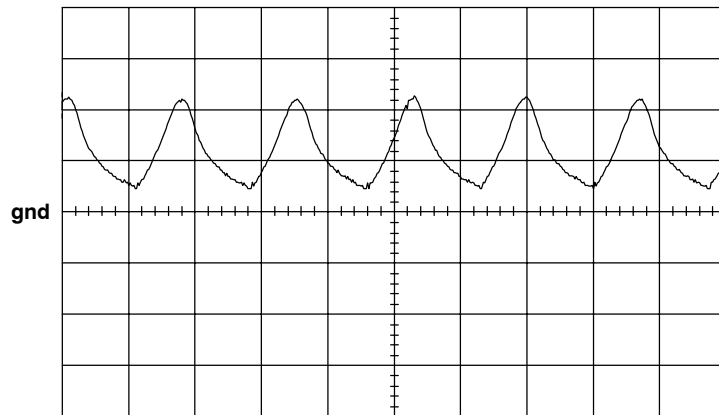

B. 25 Volts DC, 185 Amperes (Resistive Load), 60 Hz



Test Equipment Needed:

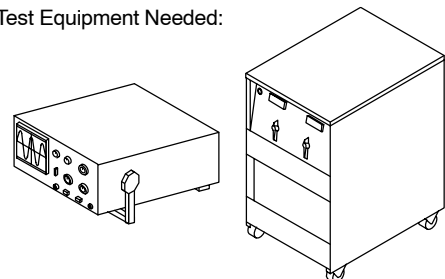

10-5. Control Board PC1 Testing Information

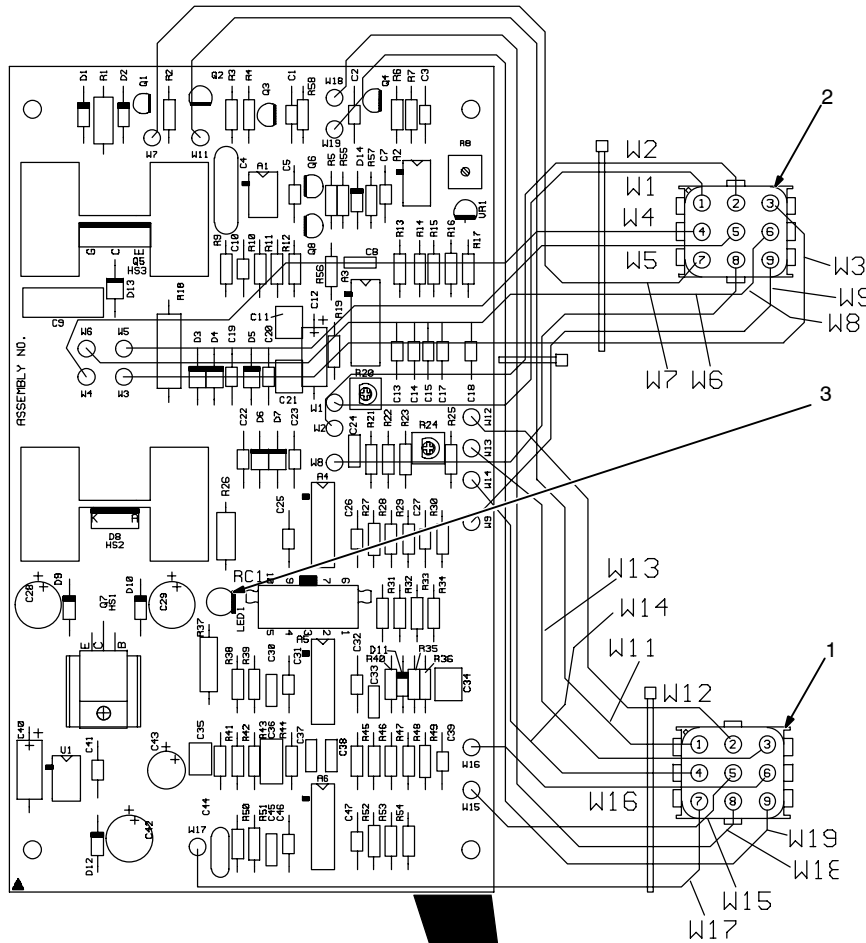

Be sure plugs are secure before testing. See Section 10-6 for specific values during testing.

- 1 Receptacle RC5
- 2 Receptacle RC4
- 3 LED1

LED1 lights when board is energized.

Test Equipment Needed:

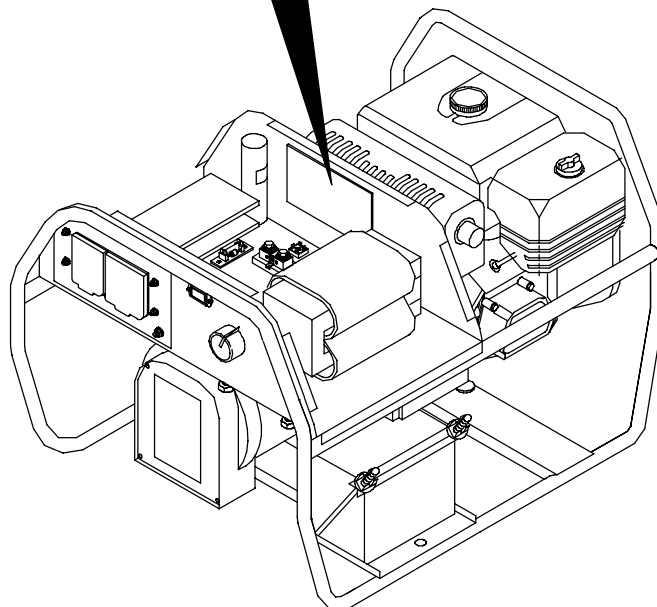
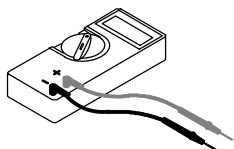

802 524 / 198 221-A

10-6. Control Board PC1 Test Point Values



PC1 Voltage Readings

- a) Tolerance - $\pm 10\%$ unless specified
- b) Condition - no load; throttle lever in 60 Hz position
- c) Reference - to circuit common (RC4-7) unless noted

Receptacle	Pin	Value
RC4	1	18 volts ac input with respect to pin 2
	2	18 volts ac input with respect to pin 1
	3	+50 volts dc output with respect to pin 4
	4	-50 volts dc output with respect to pin 3
	5	+200 volts dc input with respect to pin 6
	6	Circuit common
	7	Circuit common (shield) for shunt input
	8	Shunt negative (circuit common)
	9	Shunt positive (less than 1 volt dc input with respect to pin 8 with 100 ampere, 25 volt weld load)
RC5	1	0 volts dc
	2	+15 volts dc input
	3	Circuit common
	4	+10 volts dc output with respect to pin 6
	5	0 to +10 volts dc input from min. to max. of Current Control R1 with respect to pin 6
	6	Circuit common
	7	Weld feedback input; same as negative (-) weld output terminal voltage
	8	0 volts dc
	9	0 volts dc when engine speed is greater than 2800 rpm

10-7. Replacing Brushes And Cleaning Slip Rings

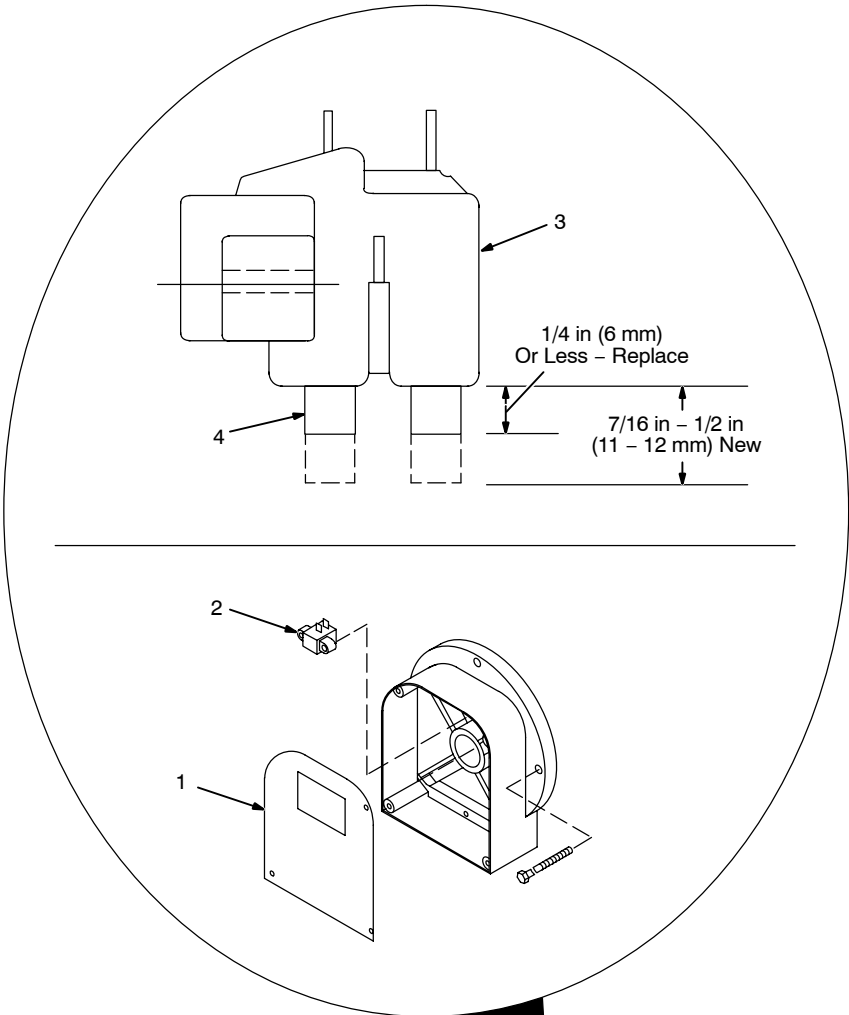
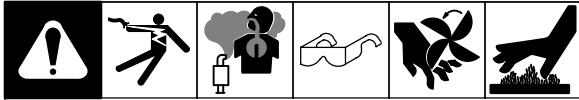

▲ Stop engine.

- 1 Generator End Panel
- 2 Brush Assembly
- 3 Brush Holder
- 4 Brushes

Remove end panel. Remove brush assembly. Pull brushes from holders.

Replace brushes if damaged, or if brush is at or near minimum length.

5 Slip Rings

Visually inspect slip rings. Under normal use, rings turn dark brown.

If slip rings are corroded or surface is uneven, insulate brush leads, start engine, and clean rings with a commutator stone. Remove as little material as possible.

▲ Stop engine. Close fuel valve.

Install brushes, brush holders, and brush arm.

Reinstall cover.

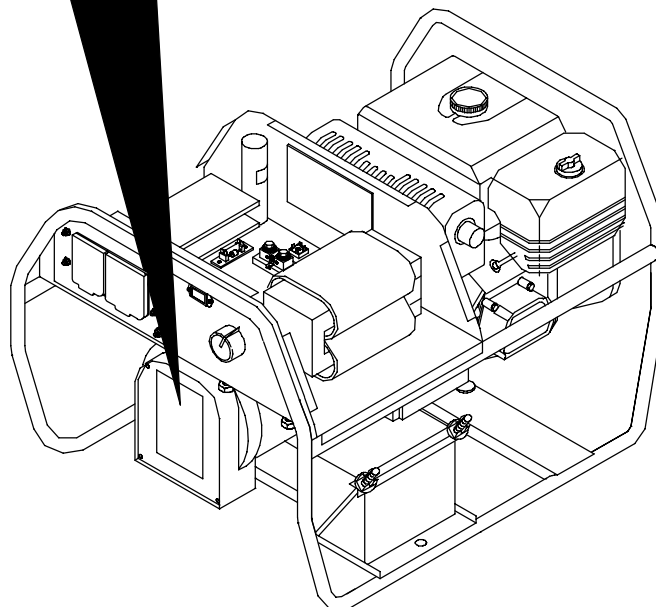

Tools Needed:

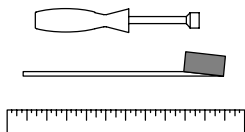

ST-802 524 / ST-801 842

10-8. Checking Unit Output After Servicing

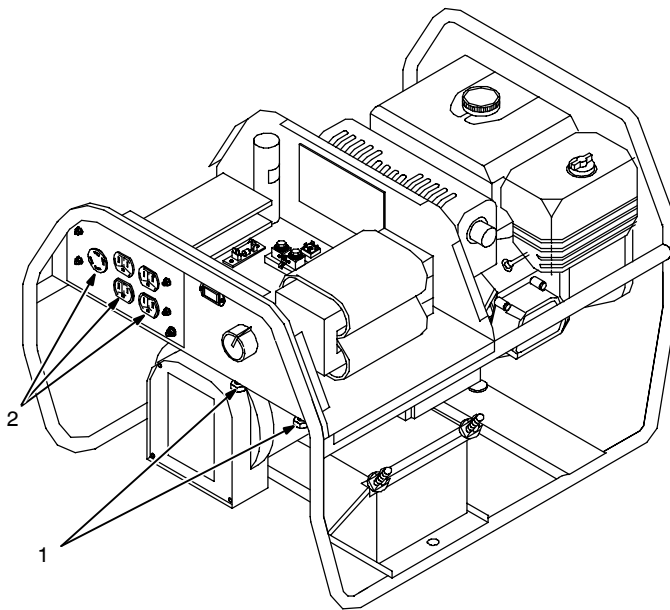
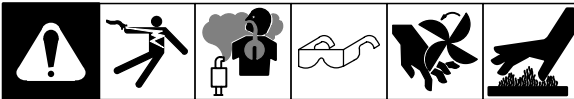

Start engine.

Move throttle control lever to 60 Hz position.

1 Weld Output Terminals

Check open-circuit voltage across weld output terminals. There should be 68 volts dc present (see Section 10-2).

2 AC Receptacles RC1, RC2, And RC3

Move throttle lever to correct position (50 or 60 Hz) for generator power. Check voltage at each receptacle. With no load applied, voltage should be 10% above receptacle rating on nameplate.

EXAMPLE: Correct no load voltage for a 120 volt receptacle should be 132 volts ac.

If generator power or weld output voltage is incorrect, adjust engine speed (see Section 7-4 or 7-5).

▲ Stop engine. Close fuel valve.

Allow engine to cool, and complete pre-operational checks in table.

Pre-Operational Checks

Wipe engine surfaces clean.

Check labels; replace labels that are unreadable or damaged.

Check fuel and oil (see Section 4-4 or 4-5).

Check and correct any fluid leaks.

Clean weld output and battery terminals. Tighten connections.

Clean outside of entire unit.

Test Equipment Needed:

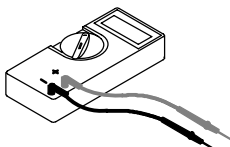

ST-802 524

SECTION 11 – DISASSEMBLY AND REASSEMBLY

11-1. Disassembly Of Unit

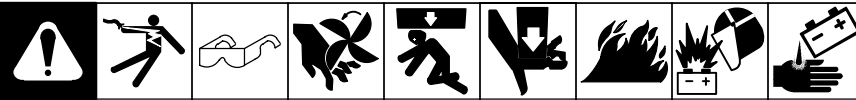

Use Section 10-2 to determine if trouble is in stator, rotor, engine or combination of these components.

Remove cover. Mark and disconnect stator leads.

Disassemble in sequence shown.

▲ Use hoist and lifting strap to carefully remove engine/generator assembly.

Go to Section 11-2.

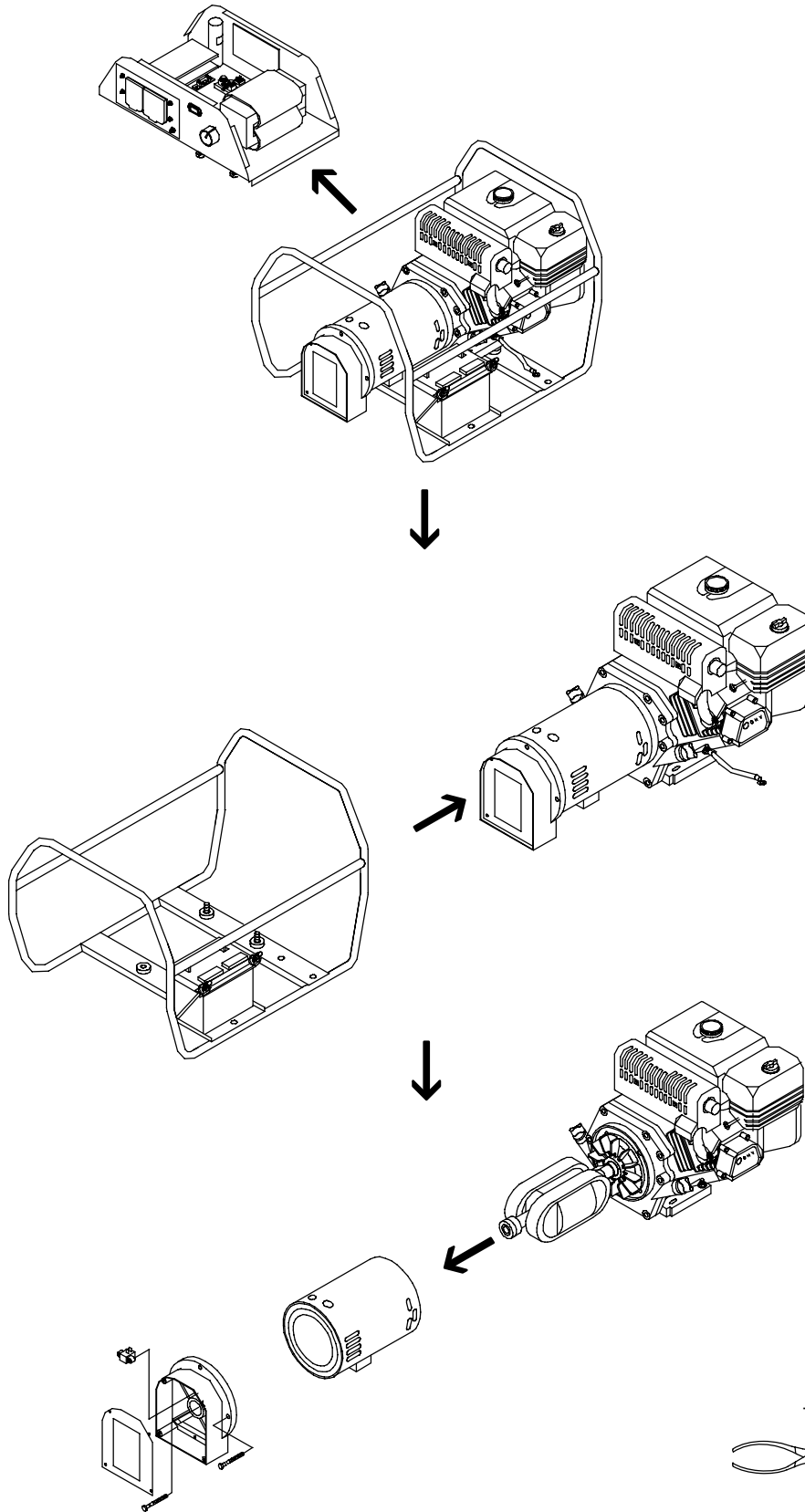

Tools Needed:



11-2. Removing Rotor And Reassembling Generator



Removing Rotor

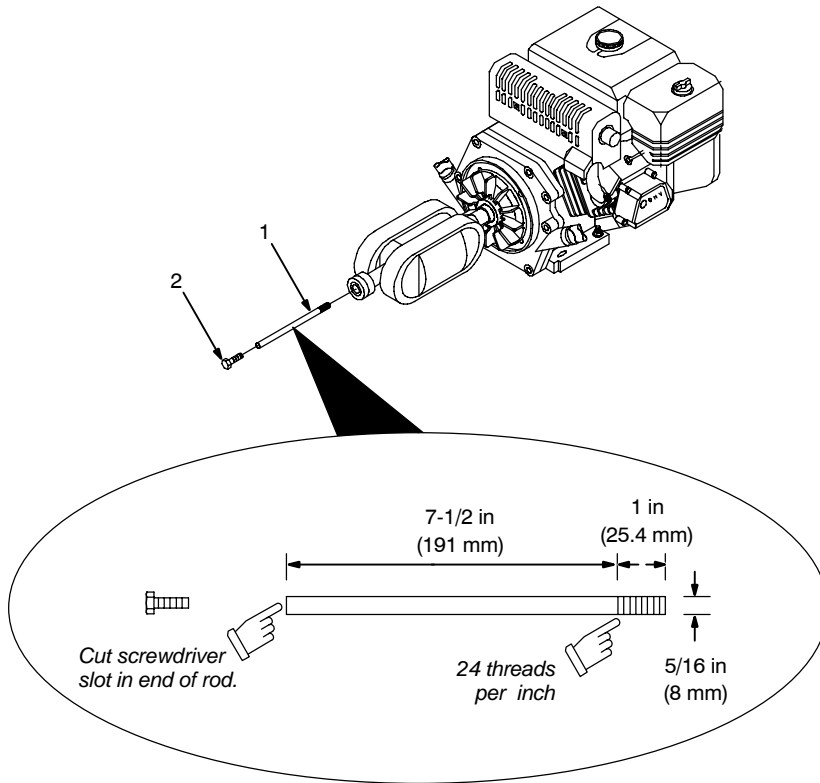

▲ Do not damage rotor or stator windings during this procedure.

To remove rotor:

- 1 Rotor Removal Tool (Customer Supplied)
- 2 Screw, 7/16-14 x 1-1/4 (Customer Supplied)

Remove rotor thru-bolt.

Make rotor removal tool from stress-proof steel rod according to specifications. Slide threaded end of tool through rotor. Tighten tool in engine shaft. Turn screw into rotor while lightly tapping rotor laminations. (turning screw into rotor forces rotor off engine shaft.)

Reassembly

- 3 Brushholder Assembly
- 4 Generator End Panel
- 5 Bearing Carrier
- 6 Rotor Assembly
- 7 Stator Assembly
- 8 Generator Fan
- 9 Generator Guard
- 10 Engine Adapter
- 11 Engine

Reinstall engine and generator parts using torque values in table.

Reconnect all leads. Use cable ties to secure leads in wiring harness and away from moving or hot parts.

Reinstall cover.

Reassembling Generator

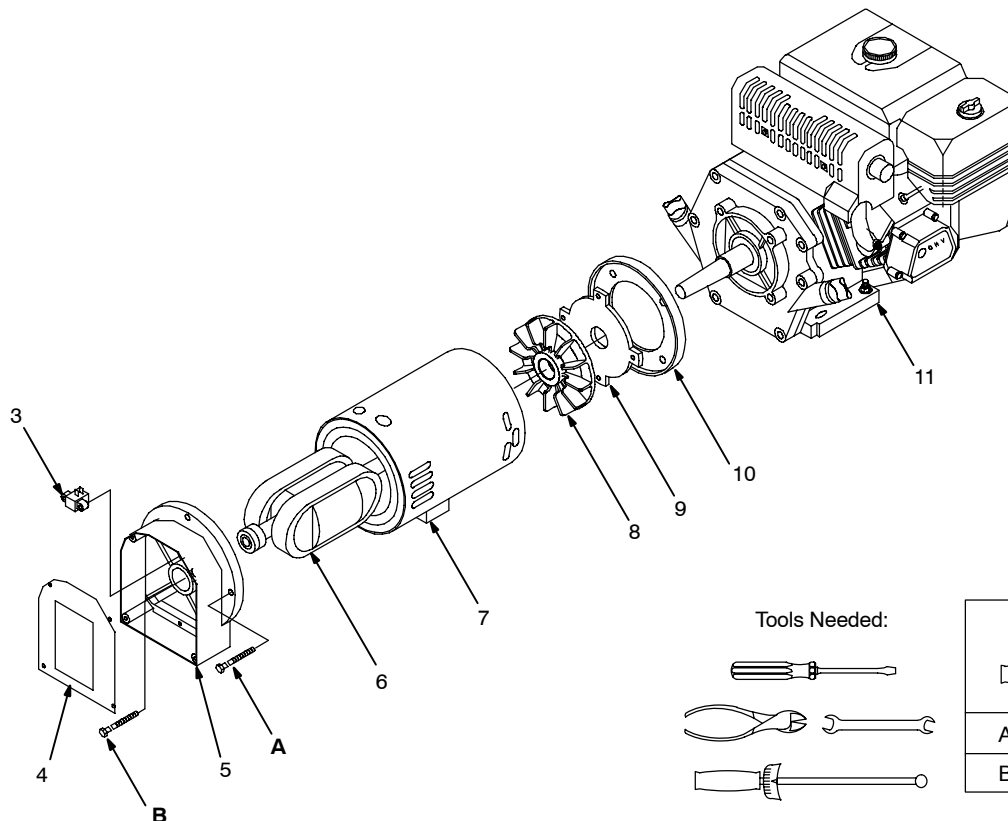

802 524 / 802 509

SECTION 12 – ELECTRICAL DIAGRAMS

 The circuits in this manual can be used for troubleshooting, but there might be minor circuit differences from your machine. Use circuit inside machine case or contact distributor for more information.

The following is a list of all diagrams for models covered by this manual.

Model	Serial Or Style Number	Circuit Diagram	Wiring Diagram
Welding Generator	LA124002 and following (Kohler) LA347885 and following (Honda)	197 857-E	197 858-C
Generator Power Panels	LA124002 and following (Kohler) LA347885 and following (Honda)		201 026-A
Circuit Board PC1	LA124002 and following (Kohler) LA033425 and following (Honda)	198 222	
Circuit Board PC2	LA124002 and following (Kohler) KH467216 and following (Honda)	SA-148 611-A	

NOTE

The circuits for Honda-powered units were implemented prior to the effective date of this manual.

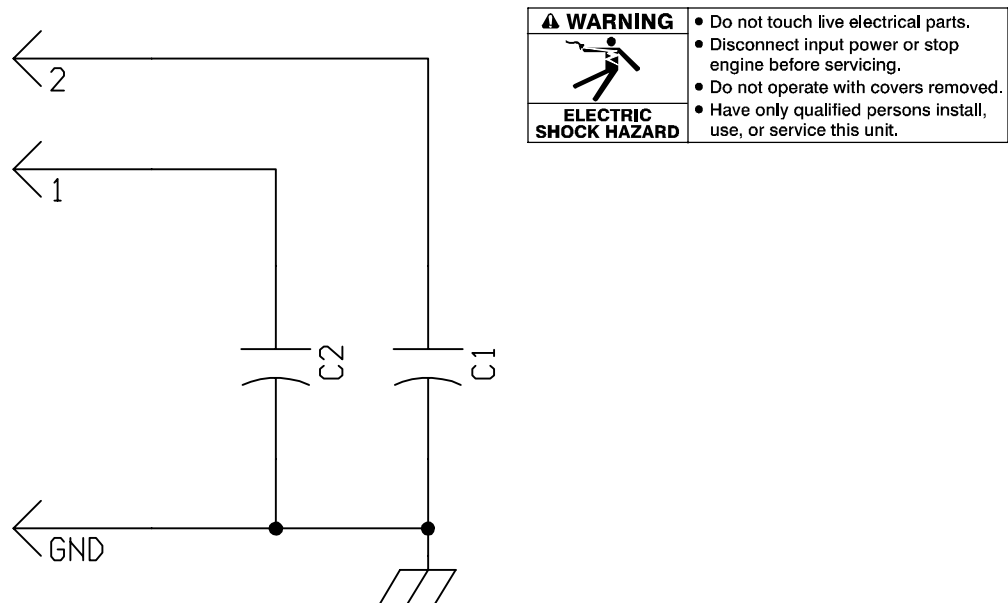

SA-148 611-A

Figure 12-1. Circuit Diagram For HF Board PC2 Eff. w/ Serial No. LA124002 And Following (Kohler) Or KH467216 And Following (Honda)

	⚠ WARNING • Do not touch live electrical parts. • Disconnect input power or stop engine before servicing. • Do not operate with covers removed. • Have only qualified persons install, use, or service this unit.
	ELECTRIC SHOCK HAZARD

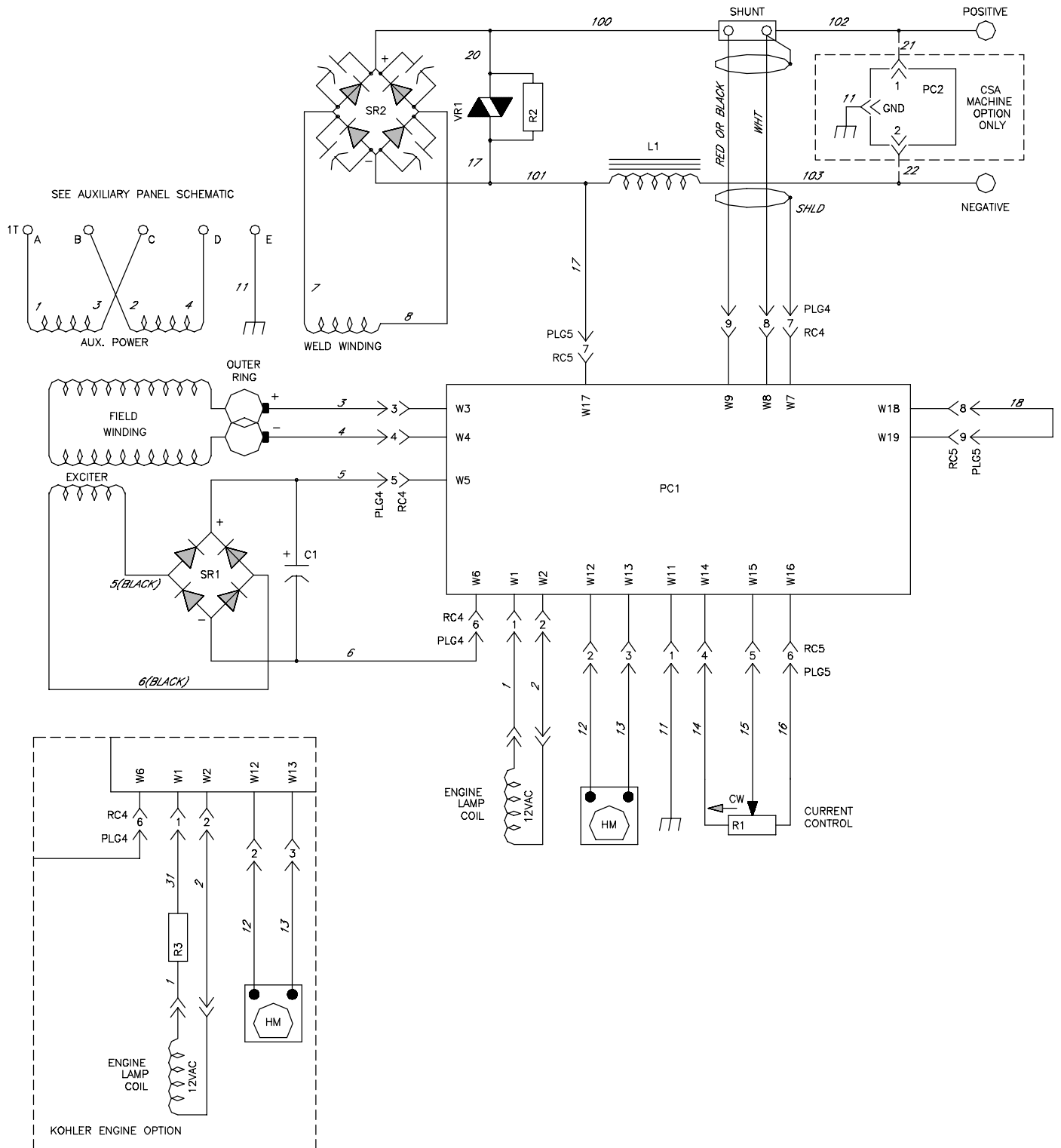
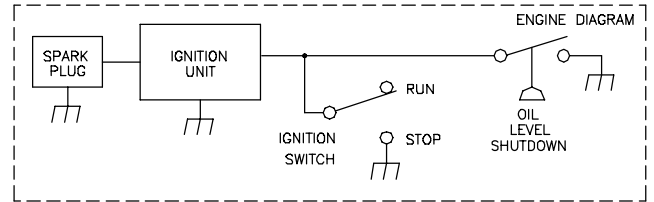

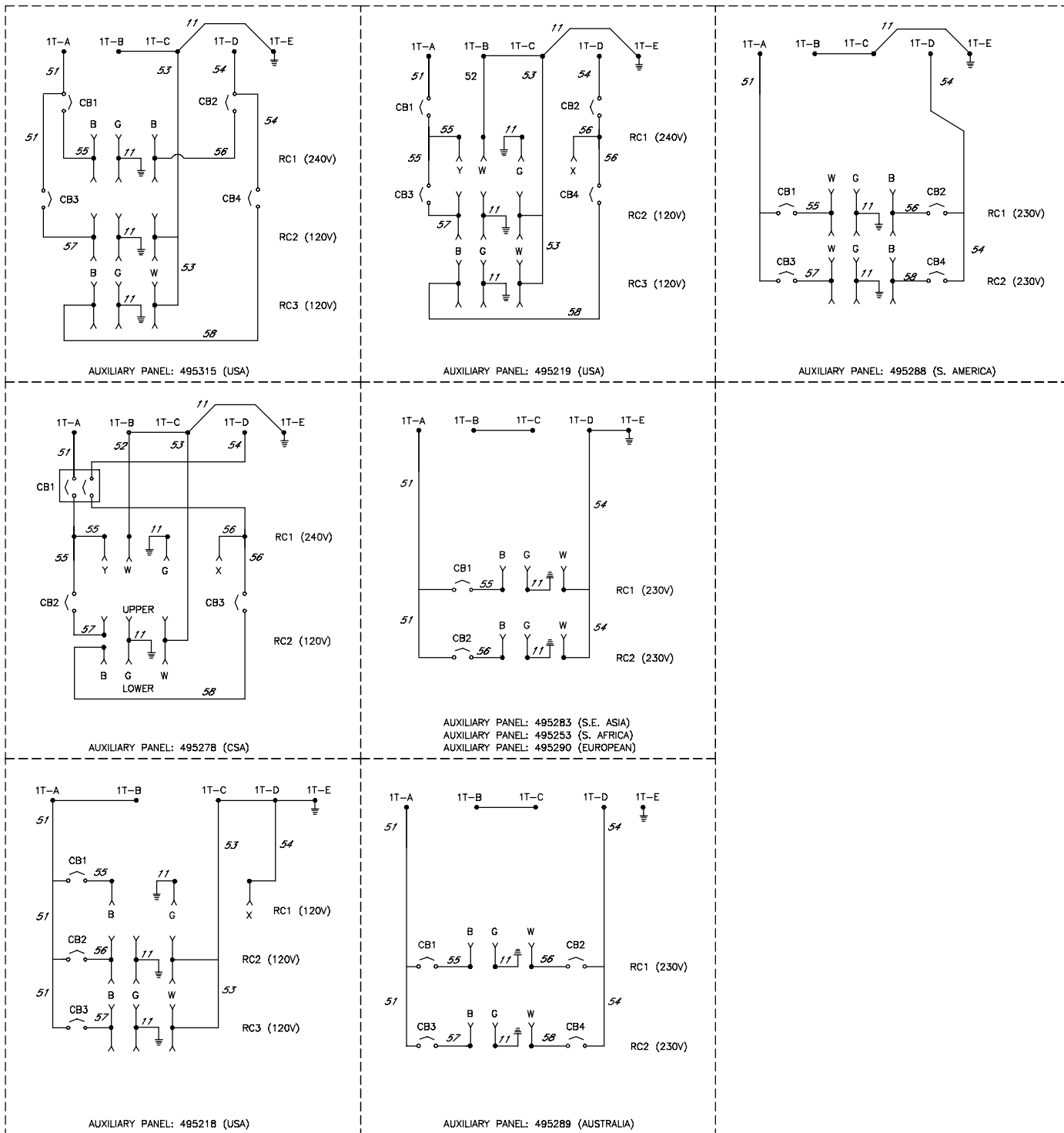

Figure 12-2. Circuit Diagram For Welding Generator Eff. w/ Serial No. LA124002 And Following (Kohler) Or LA347885 And Following (Honda) (1 Of 2)

 ELECTRIC SHOCK HAZARD	WARNING
	<ul style="list-style-type: none"> • Do not touch live electrical parts. • Disconnect input power or stop engine before servicing. • Do not operate with covers removed. • Have only qualified persons install, use, or service this unit.



197 857-E

Figure 12-3. Circuit Diagram For Welding Generator Eff. w/ Serial No. LA124002 And Following (Kohler) Or LA347885 And Following (Honda) (2 Of 2)

⚠ WARNING

ELECTRIC SHOCK HAZARD

- Do not touch live electrical parts.
- Disconnect input power or stop engine before servicing.
- Do not operate with covers removed.
- Have only qualified persons install, use, or service this unit.

Apply *small* amount of conductive electric compound (Part No. 603 978) to terminals where factory-applied compound had been present.

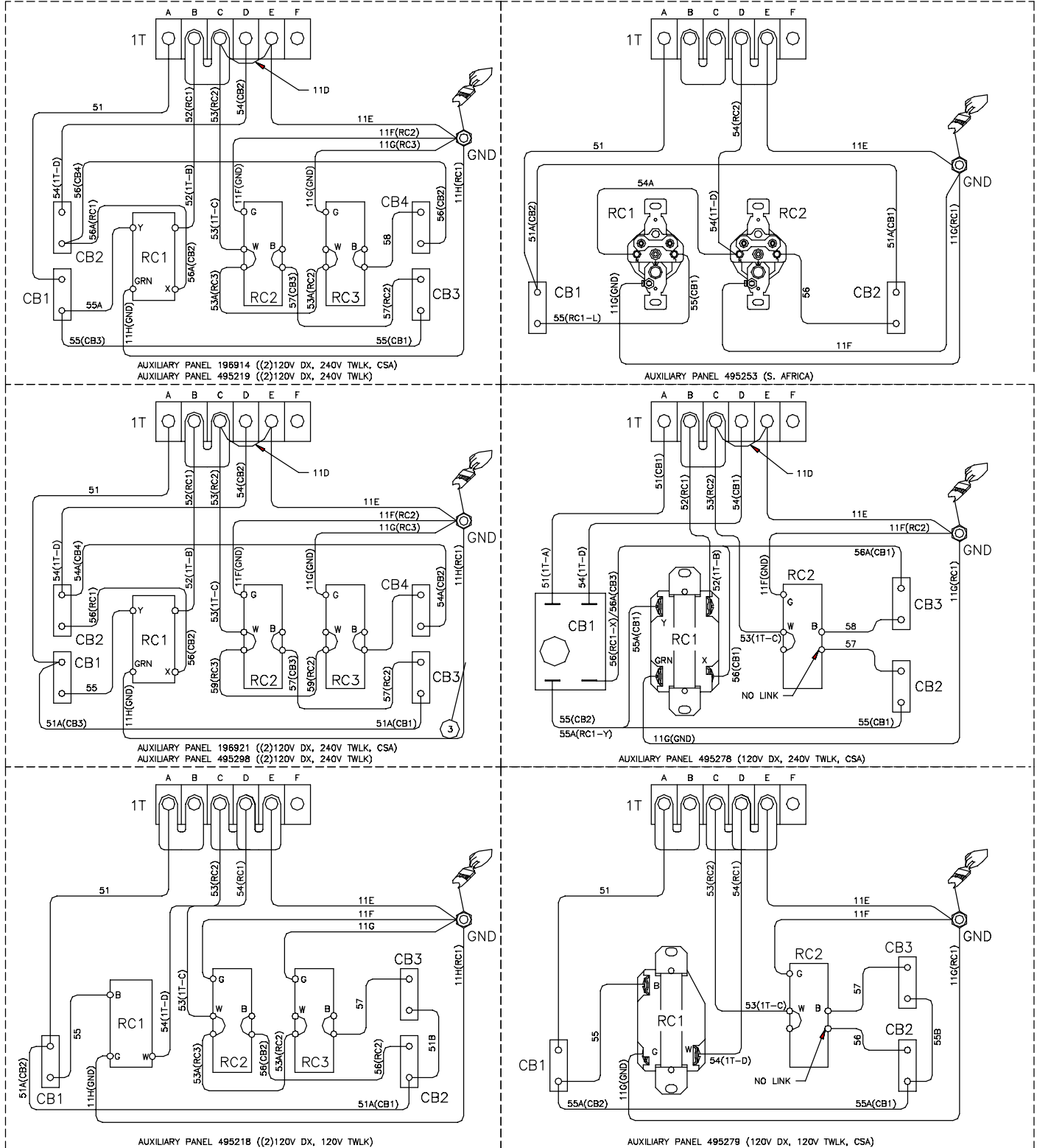
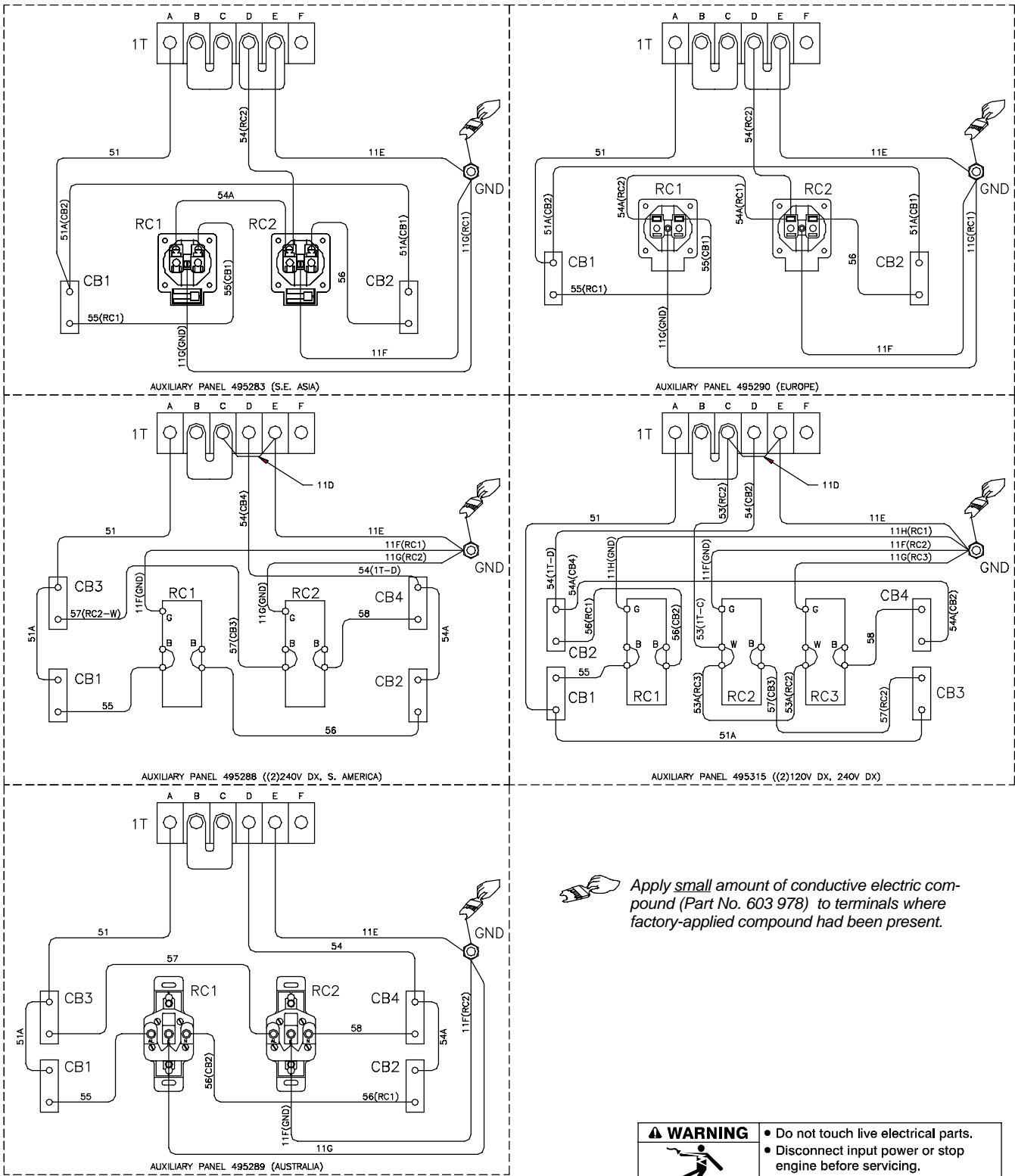

Figure 12-5. Wiring Diagram For Generator Power Panels Eff. w/ Serial No. LA124002 And Following (Kohler) Or LA347885 And Following (Honda) (1 Of 2)



Apply small amount of conductive electric compound (Part No. 603 978) to terminals where factory-applied compound had been present.

	⚠ WARNING	<ul style="list-style-type: none"> Do not touch live electrical parts. Disconnect input power or stop engine before servicing. Do not operate with covers removed.
	ELECTRIC SHOCK HAZARD	<ul style="list-style-type: none"> Have only qualified persons install, use, or service this unit.

Figure 12-6. Wiring Diagram For Generator Power Panels Eff. w/ Serial No. LA124002 And Following (Kohler) Or LA347885 And Following (Honda) (2 Of 2)

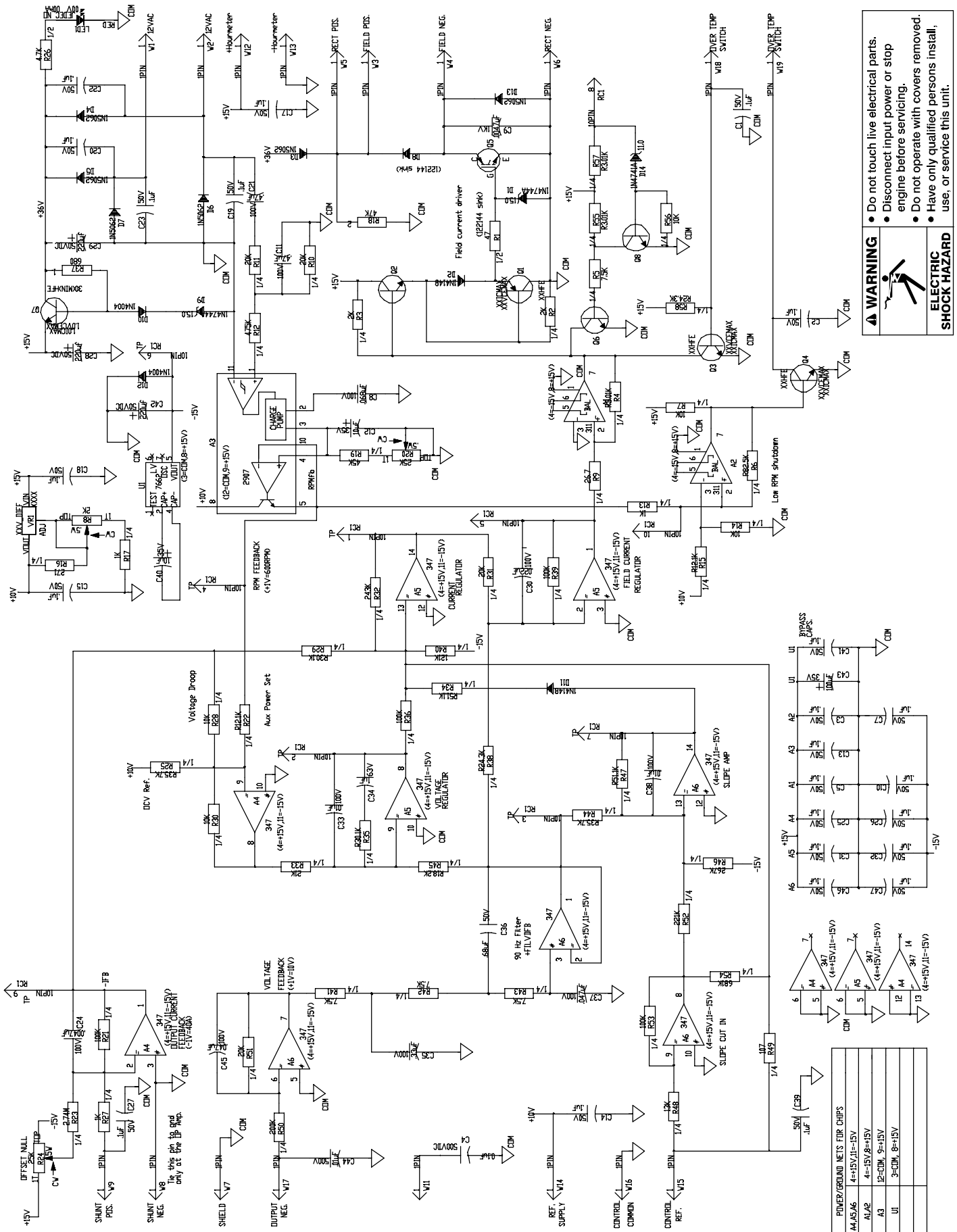

Figure 12-7. Circuit Diagram For Control Board PC1 Eff. w/ Serial No. LA124002 And Following (Kohler) Or LA033425 And Following (Honda)

Processes

Stick (SMAW) Welding

Description

Engine Driven Welding Generator

PARTS LIST

Eff w/LA124002 Thru LB111747 (Kohler Only)

For OM-499 (197 850) Revisions * Thru B

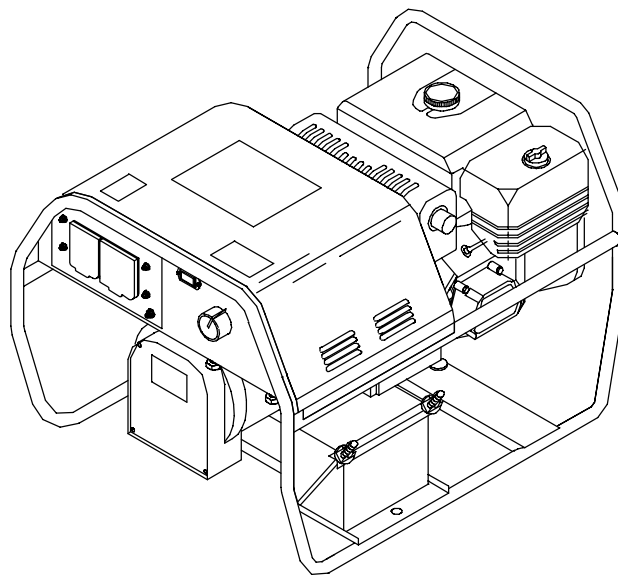

SECTION 13 – PARTS LIST FOR LA124002 THRU LB111747 (KOHLER ONLY)

 Hardware is common and not available unless listed.

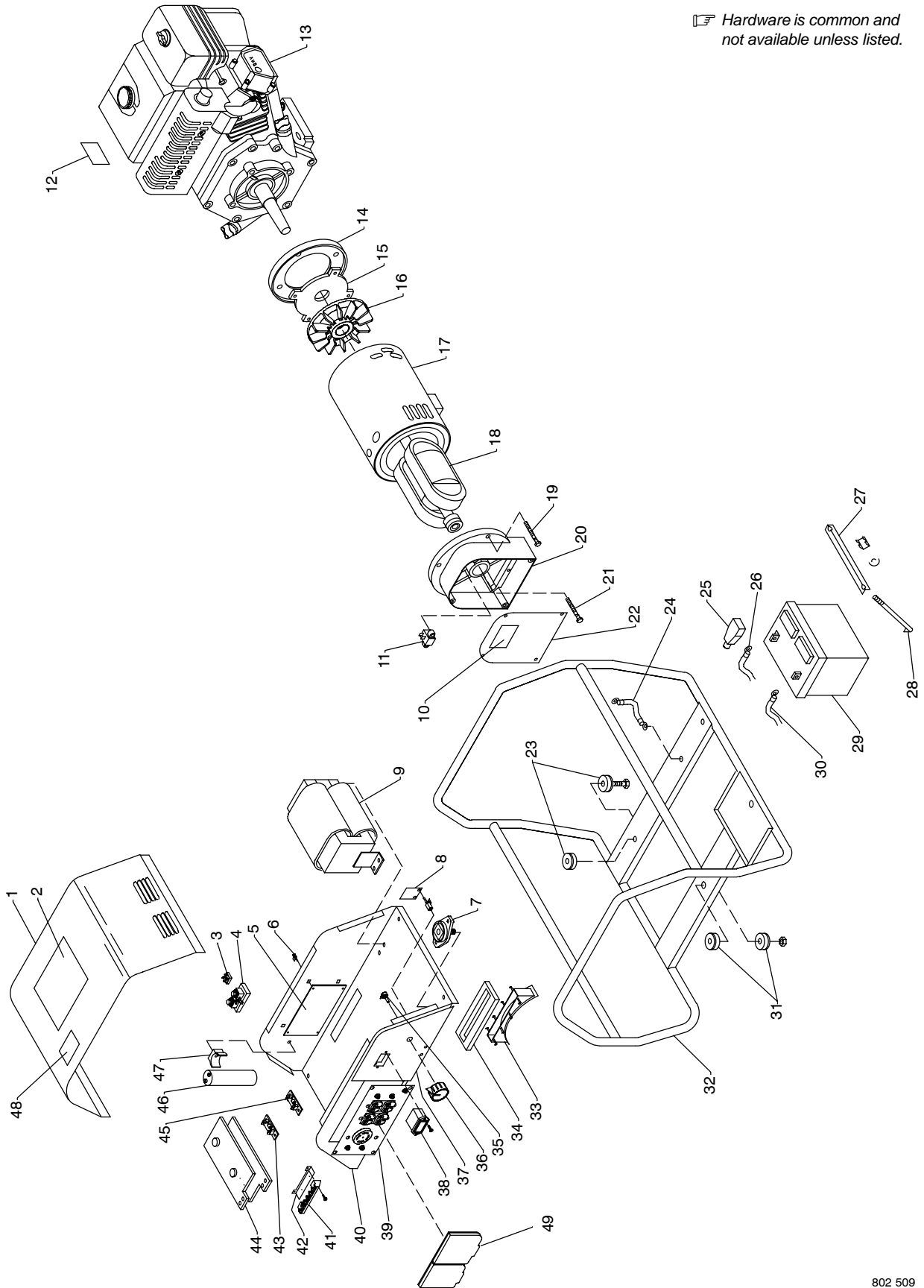

Figure 13-1. Main Assembly

802 509

Eff w/LA124002 Thru LB111747 (Kohler Only)

Item No.	Dia. Mkgs.	Part No.	Description	Quantity
Figure 13-1. Main Assembly				
...	1	.. +495 247	.. TOP, control box (specify color)	1
...	2	.. 495 096	.. LABEL, precautionary	1
...	3	SR1 .. 035 704	.. RECTIFIER, integ bridge 40 A 800 V	1
...	4	SHUNT .. 028 747	.. SHUNT, meter	1
...	5	PC1 .. 198 449	.. BOARD, PC assembly	1
...	6	.. 134 201	.. STAND-OFF, support	4
...	7	.. 494 613	.. TERMINAL, output 250V	2
...	8	PC2 .. 148 608	.. BOARD, PC filter	1
...	9	L1 .. 198 472	.. REACTOR, stabilizing	1
...	10	.. 495 095	.. LABEL, moving parts	1
...	11	.. 493 509	.. BRUSHHOLDER, assembly	1
...	12	.. 495 094	.. LABEL, warning fuel (also supplied with engine)	1
...	13	.. +195 771	.. ENGINE, Kohler 12HP (electric start)	1
...	14	.. 494 606	.. ADAPTER, engine	1
...	15	.. 494 629	.. GUARD, generator	1
...	16	.. 194 509	.. FAN, generator	1
...	17	.. 495 211	.. GENERATOR, w/stator assembly	1
...	18	.. 495 197	.. ROTOR, assembly	1
...		.. 495 154	.. BEARING	1
...	19	.. 495 349	.. SCREW, 1/4-20 HWH	4
...	20	.. 494 587	.. CARRIER, bearing	1
...	21	.. 495 348	.. SCREW, 5/16-24 HWH	1
...	22	.. +494 628	.. PANEL, end generator	1
...	23	.. 495 257	.. MOUNT, shock w/bushing	2
...	24	.. 495 113	.. LEAD, bonding	1
...	25	.. 494 039	.. COVER, battery cable	1
...	26	.. 495 111	.. LEAD, battery pos	1
...	27	.. 493 057	.. CLAMP, battery	1
...	28	.. 494 604	.. BOLT, hold down	1
...	29 BATTERY, 12V	1
...	30	.. 495 112	.. LEAD, battery neg	1
...	31	.. 495 256	.. MOUNT, shock generator	1
...	32	.. 194 504	.. FRAME, mtg assembly	1
...	33	.. 495 255	.. DUCT, air	1
...	34	.. 495 214	.. SEAL, air duct	1
...	35	R1 .. 035 897	.. POTENTIOMETER	1
...	36	.. 097 924	.. KNOB, pointer	1
...	37 NAMEPLATE, overlay (order by model & serial number)	1
...	38	HM .. 176 365	.. METER, hour	1
...	39	.. Figure 13-2	.. PANEL, gen power assembly	1
...	40	.. 495 236	.. BASE, control box	1
...	41	1T .. 172 661	.. BLOCK, terminal	1
...	42	.. 495 193	.. BRACKET, mtg terminal block	1
...	43	R2/VR1 .. 046 819	.. SUPPRESSOR, assembly	1
...	44	SR2 .. 495 189	.. RECTIFIER, assembly (w/mtg hardware)	1
...	45	R3 .. 197 795	.. RESISTOR ASSEMBLY	1
...	46	C1 .. 176 007	.. CAPACITOR	1
...	47	.. 494 915	.. CLAMP, capacitor	1
...	48	.. 495 187	.. LABEL, current selection	1
...	49	.. 188 039	.. COVER, receptacle w/gasket	1

+When ordering a component originally displaying a precautionary label, the label should also be ordered.

To maintain the factory original performance of your equipment, use only Manufacturer's Suggested Replacement Parts. Model and serial number required when ordering parts from your local distributor.

Eff w/LA124002 Thru LB111747 (Kohler Only)

Hardware is common and not available unless listed.

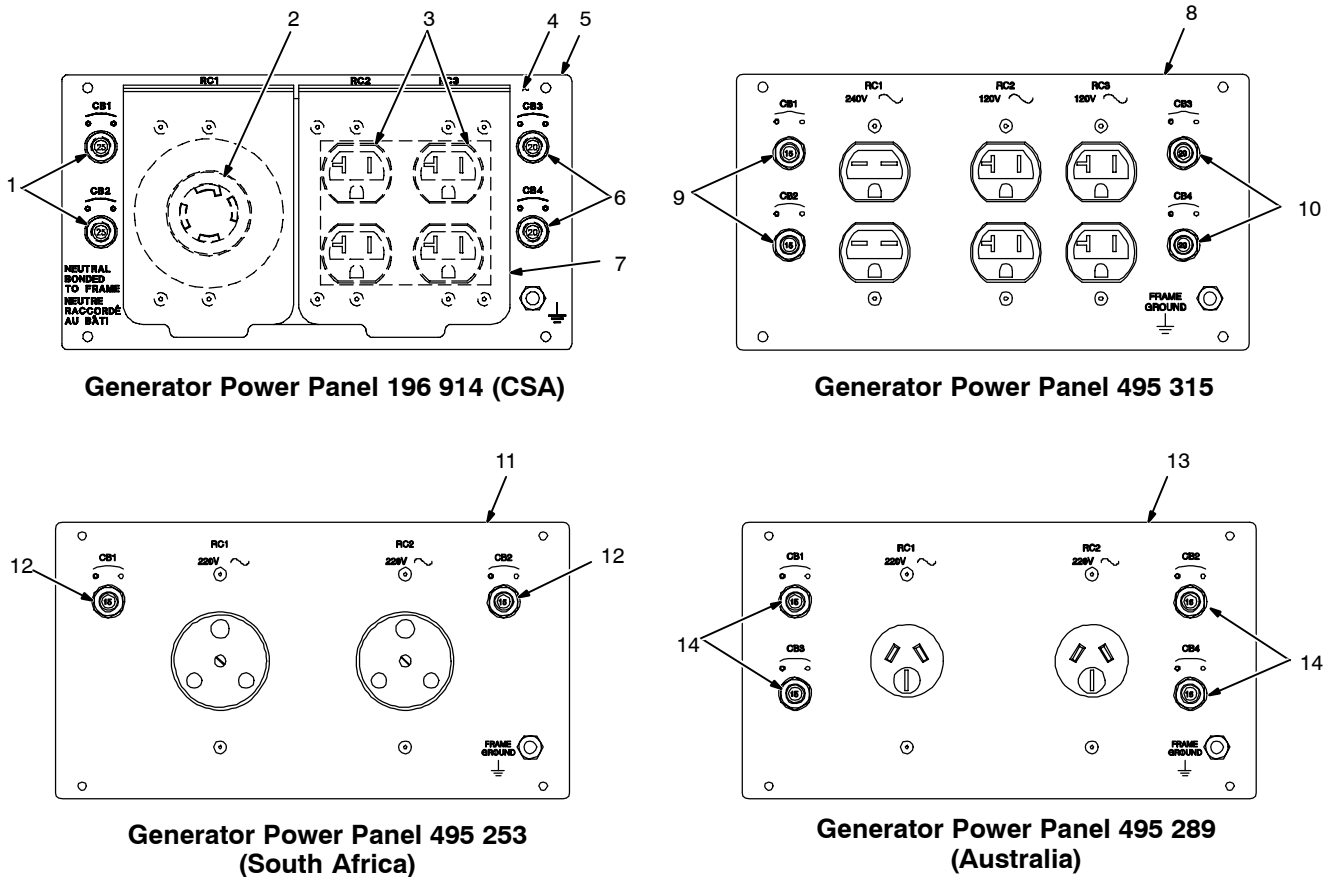

Figure 13-2. Generator Power Panels

196 921

Item No.	Dia. Mkgs.	Part No.	Description	Quantity
----------	------------	----------	-------------	----------

Figure 13-2. Generator Power Panels (Figure 13-1, Item 39)

Generator Power Panel 196 914 (CSA)

...	1	.. CB1, CB2	.. 495 182	.. Circuit Breaker, 25A	.. 2
...	2 RC1 407 749	.. Receptacle, Twistlock 240V U.S.	.. 1
...	3	.. RC2, RC3	.. 408 898	.. Receptacle, Duplex 115V 20A U.S.	.. 2
...	4 196 909	.. Label, 120/240V Gen Power Panel	.. 1
...	5 196 911	.. Panel, 120/240V Gen Power	.. 1
...	6	.. CB3, CB4	.. 495 246	.. Circuit Breaker, 20A	.. 2
...	7 188 039	.. Cover, Receptacle W/Gasket	.. 1

Generator Power Panel 495 315

...	8 495 314	.. Panel, generator power assembly	.. 1
...	9	.. CB1, CB2	.. 495 245	.. Circuit Breaker, 15A	.. 2
...	10	.. CB3, CB4	.. 495 246	.. Circuit Breaker, 20A	.. 2

Generator Power Panel 495 253 (South Africa)

...	11 495 252	.. Panel, generator power assembly	.. 1
...	12	.. CB1, CB2	.. 495 245	.. Circuit Breaker, 15A	.. 2

Generator Power Panel 495 289 (Australia)

...	13 495 254	.. Panel, generator power assembly	.. 1
...	14	.. CB1 - CB4	.. 495 245	.. Circuit Breaker, 15A	.. 4

NOTE: Replacement receptacles not listed can be found at your local hardware or electrical supply store.

To maintain the factory original performance of your equipment, use only Manufacturer's Suggested Replacement Parts. Model and serial number required when ordering parts from your local distributor.

Processes

Stick (SMAW) Welding

Description

Engine Driven Welding Generator

PARTS LIST

Eff w/LB111748 Thru LC061260 (Kohler)
Eff w/LB086216 Thru LC061260 (Honda)

For OM-499 (197 850) Revision C

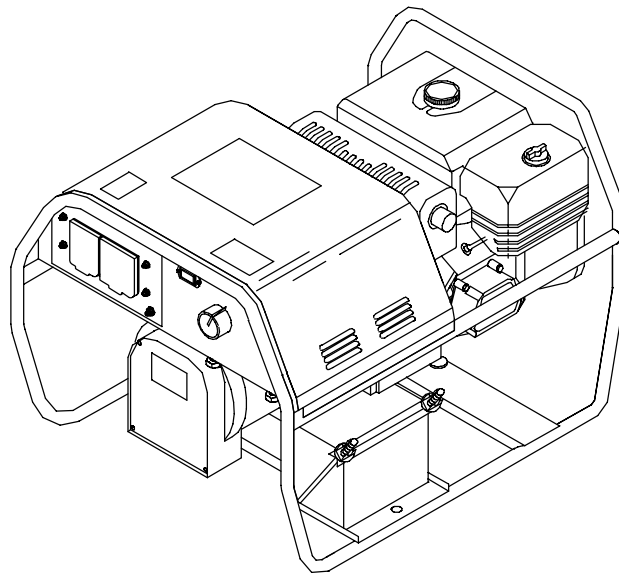

SECTION 14 – PARTS LIST FOR LB111748 THRU LC061260 (KOHLER) AND LB086216 THRU LC061260 (HONDA)

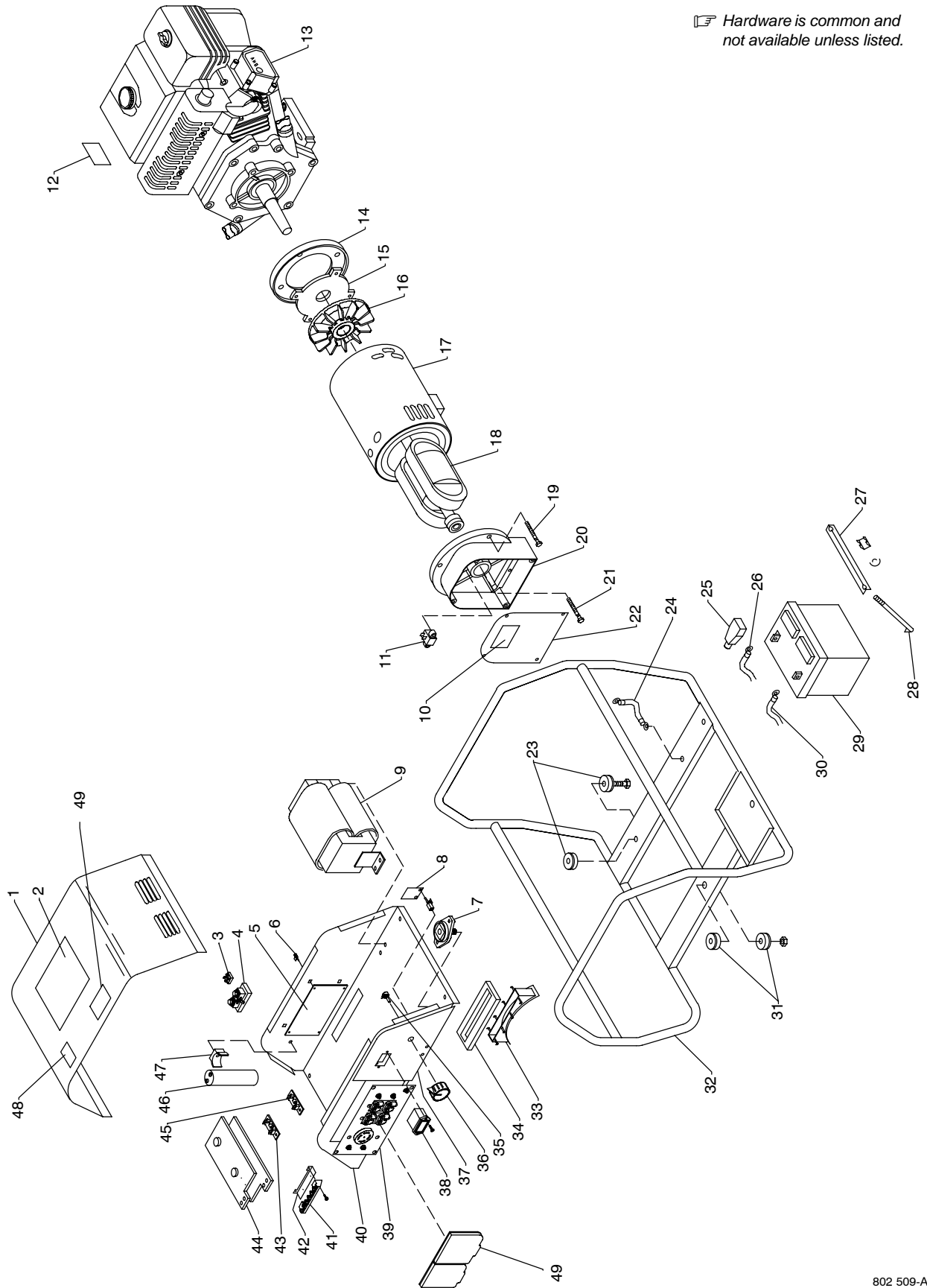

Figure 14-1. Main Assembly

Eff w/LB111748 Thru LC061260 (Kohler) / LB086216 Thru LC061260 (Honda)

Item No.	Dia. Mkgs.	Part No.	Description	Quantity
Figure 14-1. Main Assembly				
1		+495 247	TOP, control box (specify color)	1
2		495 096	LABEL, precautionary	1
3	SR1	035 704	RECTIFIER, integ bridge 40 A 800 V	1
4	SHUNT	028 747	SHUNT, meter	1
5	PC1	198 449	BOARD, PC assembly	1
6		134 201	STAND-OFF, support	4
7		494 613	TERMINAL, output 250V	2
7		129 525	TERMINAL, output Dinse 50/70 series (European models)	2
		129 527	PLUG, weld cable (European models)	2
8	PC2	148 608	BOARD, PC filter (CSA only)	1
9	L1	198 472	REACTOR, stabilizing	1
10		204 140	LABEL, moving parts	1
11		493 509	BRUSHHOLDER, assembly	1
12		204 138	LABEL, warning fuel (also supplied with engine)	1
13		+195 771	ENGINE, Kohler 12HP (electric start)	1
		*203 952	FILTER, air Kohler cs 8.5 & 12	1
		*203 954	FILTER, air pre Kohler cs 8.5 & 12	1
		*203 955	CAP, fuel Kohler cs 8.5 & 12	1
		*203 956	TANK, fuel Kohler cs 8.5 & 12	1
		*203 957	STRAINER, fuel Kohler cs 8.5 & 12	1
		*203 958	MUFFLER, exhaust engine Kohler cs 8.5 & 12	1
		*203 959	GASKET, muffler Kohler cs 8.5 & 12	1
		*203 960	SPARK PLUG, Kohler cs 8.5 & 12	1
13		+495 055	ENGINE, Honda 13HP (recoil start)	1
13		+495 053	ENGINE, Honda 13HP (electric start)	1
14		494 606	ADAPTER, engine	1
15		494 629	GUARD, generator	1
16		194 509	FAN, generator (Kohler)	1
16		493 868	FAN, generator (Honda)	1
17		495 211	GENERATOR, w/stator assembly	1
18		495 197	ROTOR, assembly	1
		495 154	BEARING	1
19		495 349	SCREW, 1/4-20 HWH	4
20		494 587	CARRIER, bearing	1
21		495 348	SCREW, 5/16-24 HWH	1
22		+494 628	PANEL, end generator	1
23		495 257	MOUNT, shock w/bushing	2
24		495 113	LEAD, bonding	1
25		494 039	COVER, battery cable	1
26		495 111	LEAD, battery pos	1
27		493 057	CLAMP, battery	1
28		494 604	BOLT, hold down	1
29			BATTERY, 12V	1
30		495 112	LEAD, battery neg	1
31		495 256	MOUNT, shock generator	1
32		194 504	FRAME, mtg assembly (Kohler)	1
32		495 132	FRAME, mtg assembly (Honda)	1
33		495 255	DUCT, air	1
34		495 214	SEAL, air duct	1
35	R1	035 897	POTENTIOMETER	1
36		097 924	KNOB, pointer	1
37			NAMEPLATE, overlay (order by model & serial number)	1
38	HM	176 365	METER, hour	1
39		Figure 14-2	PANEL, gen power assembly	1
40		495 236	BASE, control box	1

Eff w/LB111748 Thru LC061260 (Kohler) / LB086216 Thru LC061260 (Honda)

Item No.	Dia. Mkgs.	Part No.	Description	Quantity
Figure 14-1. Main Assembly (Continued)				
... 41	1T	172 661	.. BLOCK, terminal	1
... 42		495 193	.. BRACKET, mtg terminal block	1
... 43	R2/VR1	046 819	.. SUPPRESSOR, assembly	1
... 44	SR2	495 189	.. RECTIFIER, assembly (w/mtg hardware)	1
... 45	R3	197 795	.. RESISTOR ASSEMBLY (Kohler)	1
... 46	C1	176 007	.. CAPACITOR	1
... 47		494 915	.. CLAMP, capacitor	1
... 48		201 223	.. LABEL, warning electric shock power still present	1
... 49		495 187	.. LABEL, current selection	1
... 49		188 039	.. COVER, receptacle w/gasket	1

*Recommended Spare Parts.

+When ordering a component originally displaying a precautionary label, the label should also be ordered.

To maintain the factory original performance of your equipment, use only Manufacturer's Suggested Replacement Parts. Model and serial number required when ordering parts from your local distributor.

Eff w/LB111748 Thru LC061260 (Kohler) / LB086216 Thru LC061260 (Honda)

Hardware is common and not available unless listed.

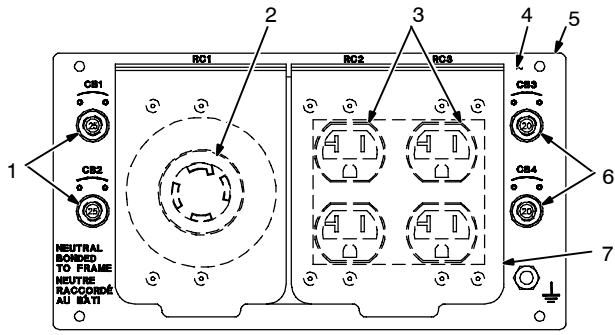

Generator Power Panel 196 914 (CSA)

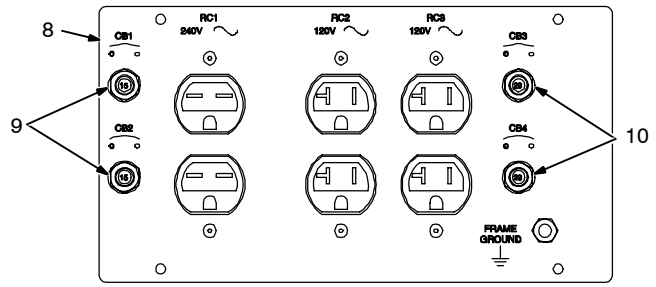

Generator Power Panel 495 315 (USA)

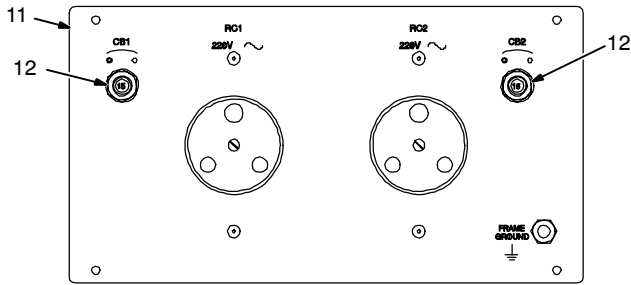

Generator Power Panel 495 253 (South Africa)

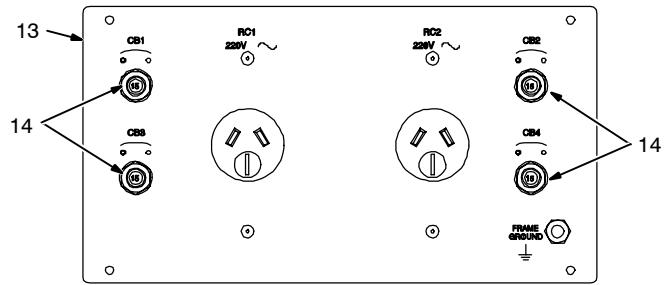

Generator Power Panel 495 289 (Australia)

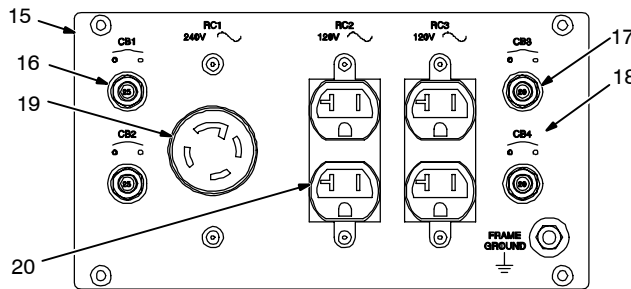

Generator Power Panel 495 219 (USA)

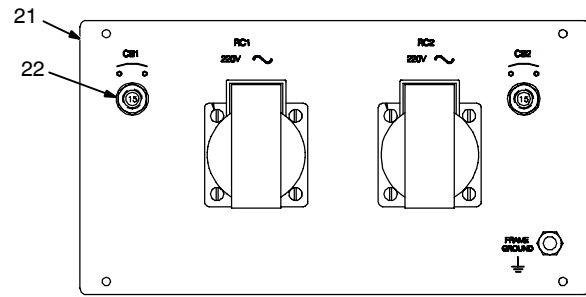

Generator Power Panel 495 290 (Europe)

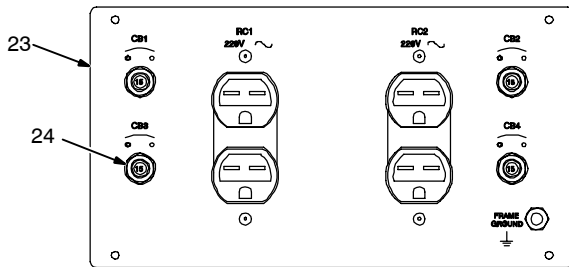

Generator Power Panel 495 288 (S. America)

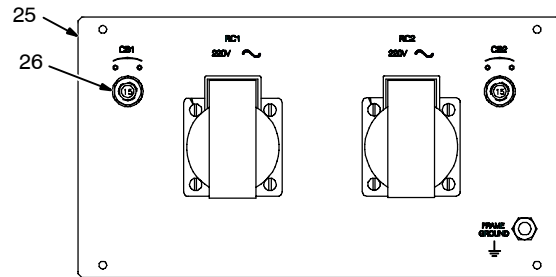

Generator Power Panel 495 283 (S.E. Asia)

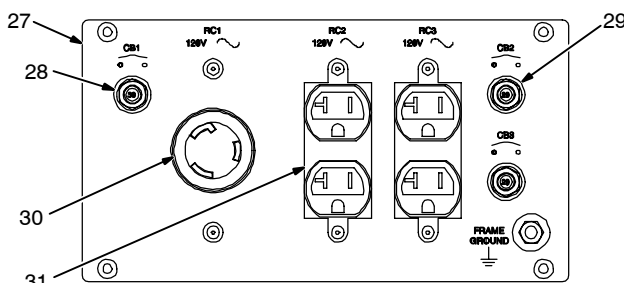

Generator Power Panel 495 298 (USA)

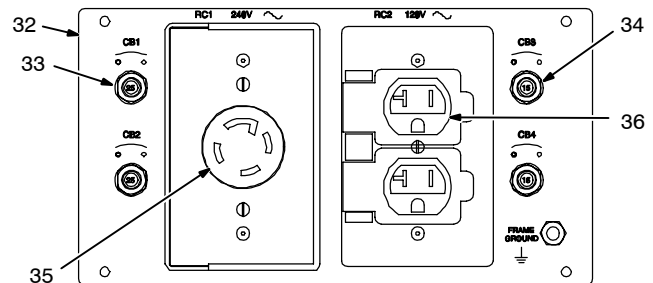

Generator Power Panel 495 278 (Canada-CSA)

196 921

Figure 14-2. Generator Power Panels

Eff w/LB111748 Thru LC061260 (Kohler) / LB086216 Thru LC061260 (Honda)

Item No.	Dia. Mkgs.	Part No.	Description	Quantity
----------	------------	----------	-------------	----------

Figure 14-2. Generator Power Panels (Figure 14-1, Item 39)

Generator Power Panel 196 914 (CSA)

1	CB1, CB2	495 182	Circuit Breaker, 25A	2
2	RC1	407 749	Receptacle, Twistlock 240V U.S.	1
3	RC2, RC3	408 898	Receptacle, Duplex 115V 20A U.S.	2
4		196 909	Label, 120/240V Gen Power Panel	1
5		196 911	Panel, 120/240V Gen Power	1
6	CB3, CB4	495 246	Circuit Breaker, 20A	2
7		188 039	Cover, Receptacle W/Gasket	1

Generator Power Panel 495 315 (USA)

8		495 314	Panel, generator power assembly	1
9	CB1, CB2	495 245	Circuit Breaker, 15A	2
10	CB3, CB4	495 246	Circuit Breaker, 20A	2

Generator Power Panel 495 253 (South Africa)

11		495 252	Panel, generator power assembly	1
12	CB1, CB2	495 245	Circuit Breaker, 15A	2

Generator Power Panel 495 289 (Australia)

13		495 254	Panel, generator power assembly	1
14	CB1 - CB4	495 245	Circuit Breaker, 15A	4

Generator Power Panel 495 219 (USA)

15		495 220	Panel, generator power assembly	1
16	CB1, CB2	495 182	CIRCUIT BREAKER, 25A	2
17	CB3, CB4	495 246	CIRCUIT BREAKER, 20A	2
18		495 217	OVERLAY	1
19	RC1	129 067	RECEPTACLE, tw lk grd 3P4W 30A 125/250V	1
		088 898	PLUG, tw lk grd 3P4W 30A 125/250V	
20	RC2, RC3	141 432	RECEPTACLE, str dx grd 2P3W 20A 125V	2
		073 690	PLUG, str grd armd 2P3W 15A 125V	

Generator Power Panel 495 290 (Europe)

21		495 282	Panel, generator power assembly	1
22	CB1, CB2	495 245	CIRCUIT BREAKER, 15A	2

Generator Power Panel 495 288 (S. America)

23		495 287	Panel, generator power assembly	1
24	CB1-4	495 245	CIRCUIT BREAKER, 15A	4

Generator Power Panel 495 283 (S.E. Asia)

25		495 282	Panel, generator power assembly	1
26	CB1, CB2	495 245	CIRCUIT BREAKER, 15A	2

Generator Power Panel 495 298 (USA)

27		495 220	Panel, generator power assembly	1
28	CB1	495 183	CIRCUIT BREAKER, 30A	1
29	CB2, CB3	495 246	CIRCUIT BREAKER, 20A	2
30	RC1	007 467	RECEPTACLE, tw lk grd 2P3W 30A 125V	1
		605 797	PLUG, tw lk 3P3W 20A 125V	
31	RC2, RC3	141 432	RECEPTACLE, str dx grd 2P3W 20A 125V	2
		073 690	PLUG, str grd armd 2P3W 15A 125V	

Generator Power Panel 495 278 (Canada-CSA)

32		495 277	Panel, generator power assembly	1
33	CB1, CB2	495 182	CIRCUIT BREAKER, 25A	1
34	CB3, CB4	495 246	CIRCUIT BREAKER, 20A	2
35	RC1	129 067	RECEPTACLE, tw lk grd 3P4W 30A 125/250V	1
		088 898	PLUG, tw lk grd 3P4W 30A 125/250V	
36	RC2	141 432	RECEPTACLE, str dx grd 2P3W 20A 125V	1
		073 690	PLUG, str grd armd 2P3W 15A 125V	

NOTE: Replacement receptacles not listed can be found at your local hardware or electrical supply store.

To maintain the factory original performance of your equipment, use only Manufacturer's Suggested Replacement Parts. Model and serial number required when ordering parts from your local distributor.

Processes

Stick (SMAW) Welding

Description

Engine Driven Welding Generator

PARTS LIST

Eff w/LC061261 Thru LC552236 (Kohler & Honda)

For OM-499 (197 850) Revisions D Thru F

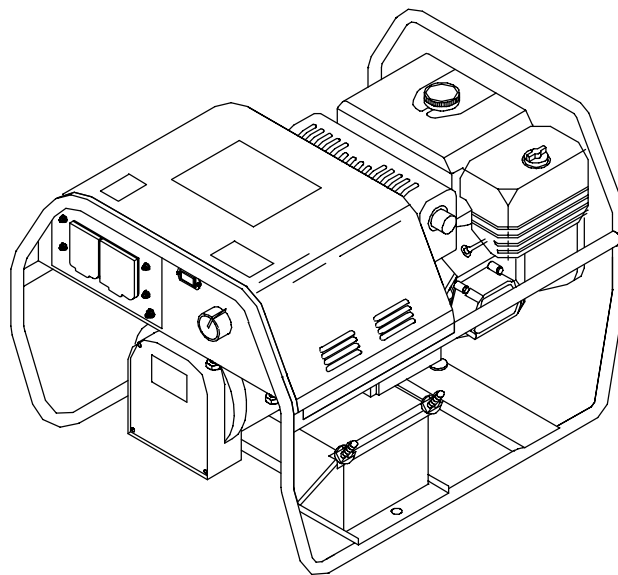

SECTION 15 – PARTS LIST FOR LC061261 THRU LC552236 (KOHLER & HONDA)

 Hardware is common and not available unless listed.

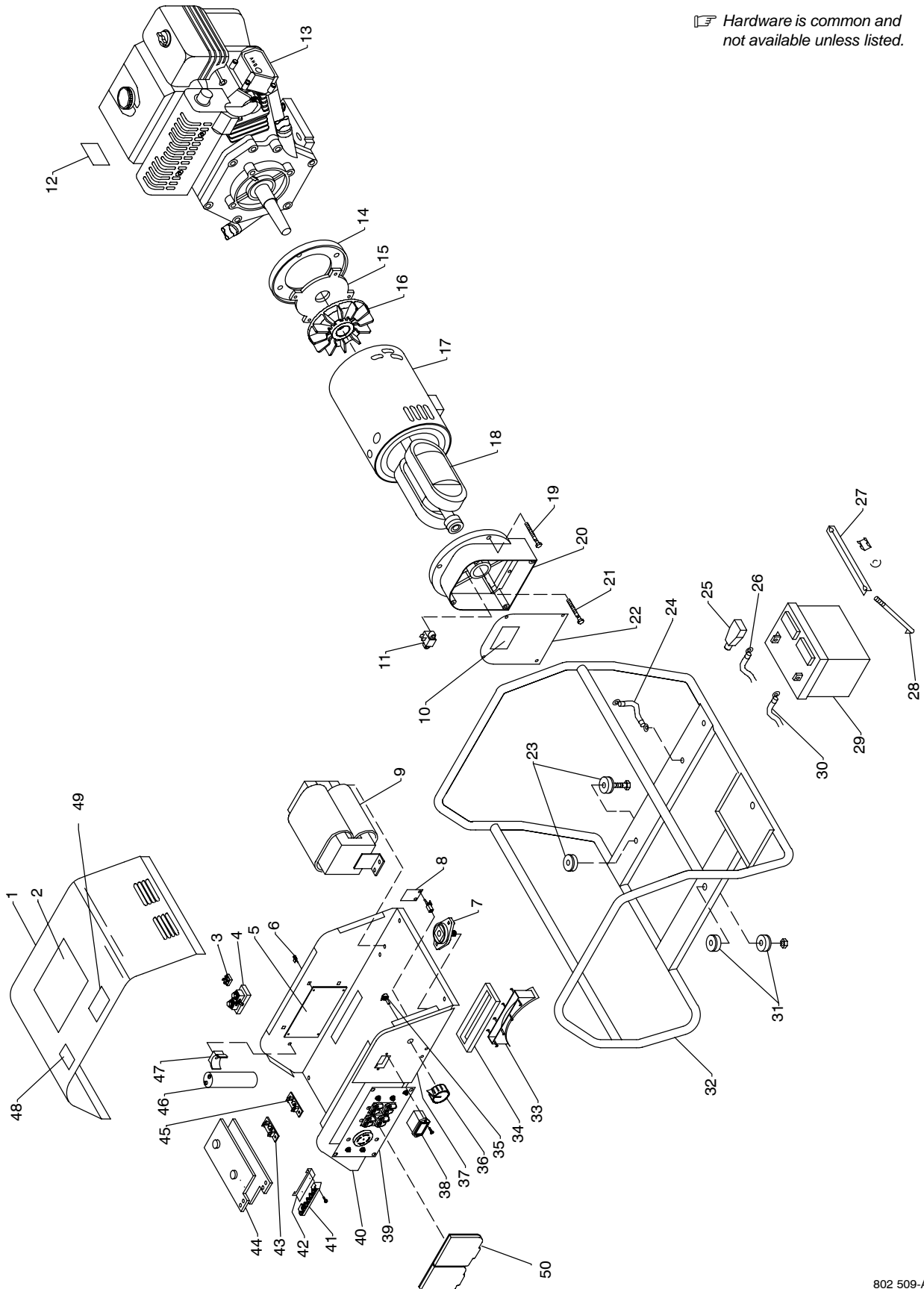

Figure 15-1. Main Assembly

802 509-A

Eff w/LC061261 Thru LC552236 (Kohler & Honda)

Item No.	Dia. Mkgs.	Part No.	Description	Quantity
Figure 15-1. Main Assembly				
...	1	.. +495 247	.. TOP, control box (specify color)	1
...	2	.. 495 096	.. LABEL, precautionary	1
...	3	.. SR1 .. 035 704	.. RECTIFIER, integ bridge 40 A 800 V	1
...	4	.. SHUNT .. 028 747	.. SHUNT, meter	1
...	5	.. PC1 .. 198 449	.. BOARD, PC assembly	1
...	6	.. 134 201	.. STAND-OFF, support	4
...	7	.. 494 613	.. TERMINAL, output 250V	2
...	7	.. 129 525	.. TERMINAL, output Dinse 50/70 series (European models)	2
...		.. 129 527	.. PLUG, weld cable (European models)	2
...	8	.. PC2 .. 148 608	.. BOARD, PC filter (CSA only)	1
...	9	.. L1 .. 198 472	.. REACTOR, stabilizing	1
...	10	.. 204 140	.. LABEL, moving parts	1
...	11	.. 493 509	.. BRUSHHOLDER, assembly	1
...	12	.. 204 138	.. LABEL, warning fuel (also supplied with engine)	1
...	13	.. +195 771	.. ENGINE, Kohler 12HP (electric start)	1
...		.. *203 952	.. FILTER, air Kohler cs 8.5 & 12	1
...		.. *203 954	.. FILTER, air pre Kohler cs 8.5 & 12	1
...		.. *203 955	.. CAP, fuel Kohler cs 8.5 & 12	1
...		.. *203 956	.. TANK, fuel Kohler cs 8.5 & 12	1
...		.. *203 957	.. STRAINER, fuel Kohler cs 8.5 & 12	1
...		.. *203 958	.. MUFFLER, exhaust engine Kohler cs 8.5 & 12	1
...		.. *203 959	.. GASKET, muffler Kohler cs 8.5 & 12	1
...		.. *203 960	.. SPARK PLUG, Kohler cs 8.5 & 12	1
...	13	.. +495 055	.. ENGINE, Honda 13HP (recoil start)	1
...	13	.. +495 053	.. ENGINE, Honda 13HP (electric start)	1
...	14	.. 494 606	.. ADAPTER, engine	1
...	15	.. 494 629	.. GUARD, generator	1
...	16	.. 194 509	.. FAN, generator (Kohler)	1
...	16	.. 493 868	.. FAN, generator (Honda)	1
...	17	.. 495 211	.. GENERATOR, w/stator assembly (Prior to LC232853)	1
...	17	.. 204 469	.. GENERATOR, w/stator assembly (Eff w/LC232853)	1
...	18	.. 495 197	.. ROTOR, assembly	1
...		.. 495 154	.. BEARING	1
...	19	.. 495 349	.. SCREW, 1/4-20 HWH	4
...	20	.. 494 587	.. CARRIER, bearing	1
...	21	.. 495 348	.. SCREW, 5/16-24 HWH	1
...	22	.. +494 628	.. PANEL, end generator	1
...	23	.. 495 257	.. MOUNT, shock w/bushing	2
...	24	.. 495 113	.. LEAD, bonding	1
...	25	.. 494 039	.. COVER, battery cable	1
...	26	.. 495 111	.. LEAD, battery pos	1
...	27	.. 493 057	.. CLAMP, battery	1
...	28	.. 494 604	.. BOLT, hold down	1
...	29 BATTERY, 12V	1
...	30	.. 495 112	.. LEAD, battery neg	1
...	31	.. 495 256	.. MOUNT, shock generator	1
...	32	.. 194 504	.. FRAME, mtg assembly (Kohler)	1
...	32	.. 495 132	.. FRAME, mtg assembly (Honda)	1
...	33	.. 495 255	.. DUCT, air	1
...	34	.. 495 214	.. SEAL, air duct	1
...	35	.. R1 .. 035 897	.. POTENTIOMETER	1
...	36	.. 097 924	.. KNOB, pointer	1
...	37 NAMEPLATE, overlay (order by model & serial number)	1
...	38	.. HM .. 176 365	.. METER, hour	1
...	39	.. Figure 15-2	.. PANEL, gen power assembly	1

Eff w/LC061261 Thru LC552236 (Kohler & Honda)

Item No.	Dia. Mkgs.	Part No.	Description	Quantity
Figure 15-1. Main Assembly (Continued)				
... 40		495 236	.. BASE, control box	1
... 41	1T	172 661	.. BLOCK, terminal	1
... 42		495 193	.. BRACKET, mtg terminal block	1
... 43	R2/VR1	046 819	.. SUPPRESSOR, assembly	1
... 44	SR2	495 189	.. RECTIFIER, assembly (w/mtg hardware)	1
... 45	R3	197 795	.. RESISTOR ASSEMBLY (Kohler)	1
... 46	C1	176 007	.. CAPACITOR	1
... 47		494 915	.. CLAMP, capacitor	1
... 48		201 223	.. LABEL, warning electric shock power still present	1
... 49		495 187	.. LABEL, current selection	1
... 50		188 039	.. COVER, receptacle w/gasket	1

*Recommended Spare Parts.

+When ordering a component originally displaying a precautionary label, the label should also be ordered.

To maintain the factory original performance of your equipment, use only Manufacturer's Suggested Replacement Parts. Model and serial number required when ordering parts from your local distributor.

Eff w/LC061261 Thru LC552236 (Kohler & Honda)

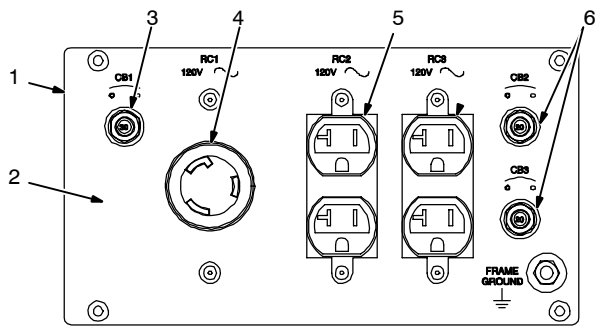

Generator Power Panel 495 218 (USA)

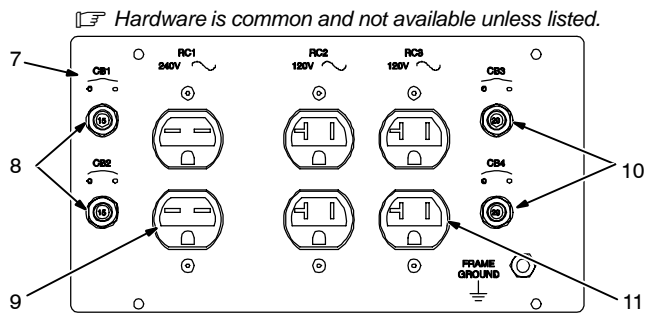

Generator Power Panel 495 315 (USA)

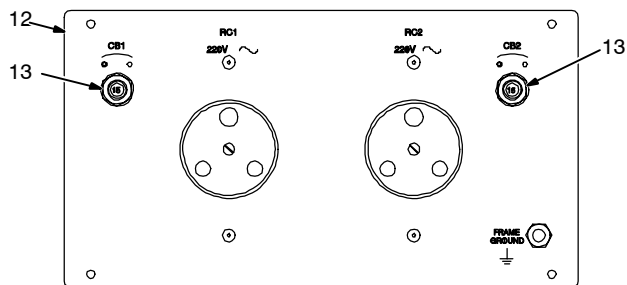

Generator Power Panel 495 253 (South Africa)

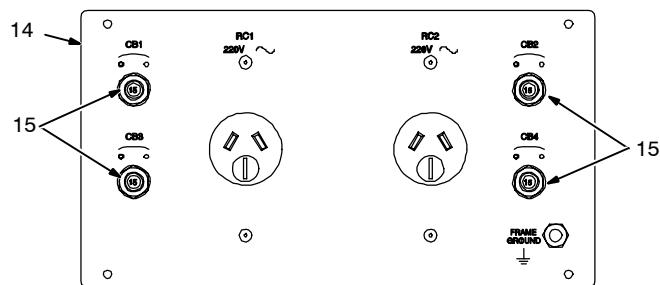

Generator Power Panel 495 289 (Australia)

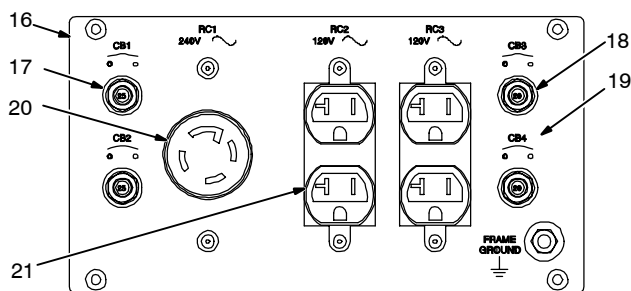

Generator Power Panel 495 219 (USA)

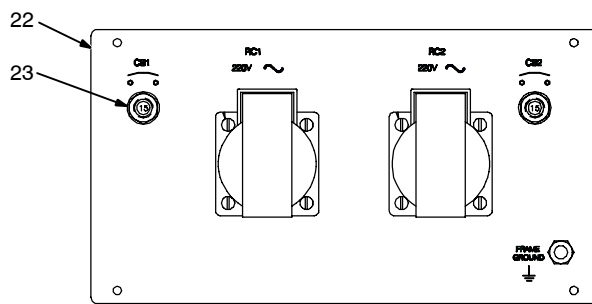

Generator Power Panel 495 290 (Europe)

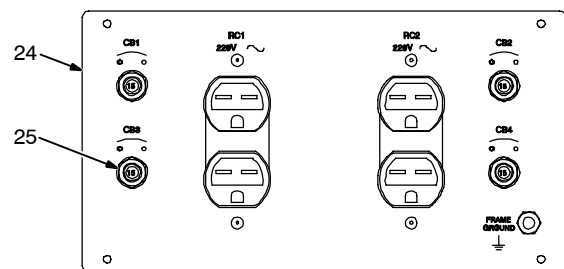

Generator Power Panel 495 288 (S. America)

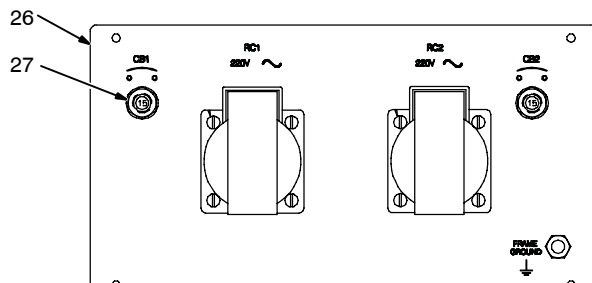

Generator Power Panel 495 283 (S.E. Asia)

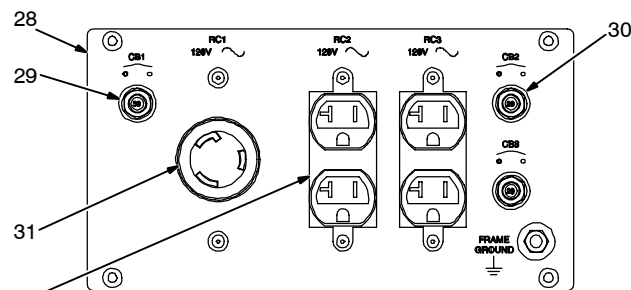

Generator Power Panel 495 298 (USA)

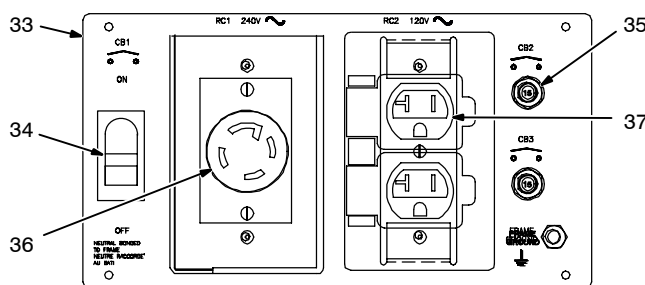

Generator Power Panel 495 278 (Canada-CSA)

Figure 15-2. Generator Power Panels

Eff w/LC061261 Thru LC552236 (Kohler & Honda)

Item No.	Dia. Mkgs.	Part No.	Description	Quantity
----------	------------	----------	-------------	----------

Figure 15-2. Generator Power Panels (Figure 15-1, Item 39)

Generator Power Panel 495 218 (USA)

...	1	495 220	..	PANEL, generator power assembly	1
...	2	495 216	..	OVERLAY	1
...	3	CB1	495 183	..	CIRCUIT BREAKER, 30A	1
...	4	007 467	..	RECEPTACLE, twistlock grd 2P3W 30A 125 V	1
...	5	408 898	..	RECEPTACLE, duplex 115 V 20 A	2
...	6	CB2, CB3	495 246	..	CIRCUIT BREAKER, 20A	2

Generator Power Panel 495 315 (USA)

...	7	495 314	..	PANEL, generator power assembly	1
...	8	CB1, CB2	495 245	..	CIRCUIT BREAKER, 15A	2
...	9	404 089	..	RECEPTACLE, Duplex 230 V S. American	1
...	10	CB3, CB4	495 246	..	CIRCUIT BREAKER, 20A	2
...	11	408 898	..	RECEPTACLE, Duplex 115 V 20 A U.S.	2

Generator Power Panel 495 253 (South Africa)

...	12	495 252	..	PANEL, generator power assembly	1
...	13	CB1, CB2	495 245	..	CIRCUIT BREAKER, 15A	2

Generator Power Panel 495 289 (Australia)

...	14	495 254	..	PANEL, generator power assembly	1
...	15	CB1 - CB4	495 245	..	CIRCUIT BREAKER, 15A	4

Generator Power Panel 495 219 (USA)

...	16	495 220	..	PANEL, generator power assembly	1
...	17	CB1, CB2	495 182	..	CIRCUIT BREAKER, 25A	2
...	18	CB3, CB4	495 246	..	CIRCUIT BREAKER, 20A	2
...	19	495 217	..	OVERLAY	1
...	20	RC1	129 067	..	RECEPTACLE, tw lk grd 3P4W 30A 125/250V	1
.....			088 898	..	PLUG, tw lk grd 3P4W 30A 125/250V	
...	21	RC2, RC3	141 432	..	RECEPTACLE, str dx grd 2P3W 20A 125V	2
.....			073 690	..	PLUG, str grd armd 2P3W 15A 125V	

Generator Power Panel 495 290 (Europe)

...	22	495 282	..	PANEL, generator power assembly	1
...	23	CB1, CB2	495 245	..	CIRCUIT BREAKER, 15A	2

Generator Power Panel 495 288 (S. America)

...	24	495 287	..	PANEL, generator power assembly	1
...	25	CB1-4	495 245	..	CIRCUIT BREAKER, 15A	4

Generator Power Panel 495 283 (S.E. Asia)

...	26	495 282	..	Panel, generator power assembly	1
...	27	CB1, CB2	495 245	..	CIRCUIT BREAKER, 15A	2

Generator Power Panel 495 298 (USA)

...	28	495 220	..	PANEL, generator power assembly	1
...	29	CB1	495 183	..	CIRCUIT BREAKER, 30A	1
...	30	CB2, CB3	495 246	..	CIRCUIT BREAKER, 20A	2
...	31	RC1	007 467	..	RECEPTACLE, tw lk grd 2P3W 30A 125V	1
.....			605 797	..	PLUG, tw lk 3P3W 20A 125V	
...	32	RC2, RC3	141 432	..	RECEPTACLE, str dx grd 2P3W 20A 125V	2
.....			073 690	..	PLUG, str grd armd 2P3W 15A 125V	

Generator Power Panel 495 278 (Canada-CSA)

...	33	495 277	..	PANEL, generator power assembly	1
...	34	CB1	203 095	..	CIRCUIT BREAKER, 25A	1
.....			202 631	..	COVER, circuit breaker	1
.....			202 630	..	BRACKET, mtg circuit breaker cover	1
...	35	CB2, CB3	495 246	..	CIRCUIT BREAKER, 20A	2
...	36	RC1	129 067	..	RECEPTACLE, tw lk grd 3P4W 30A 125/250V	1
.....			088 898	..	PLUG, tw lk grd 3P4W 30A 125/250V	
...	37	RC2	141 432	..	RECEPTACLE, str dx grd 2P3W 20A 125V	1
.....			073 690	..	PLUG, str grd armd 2P3W 15A 125V	

NOTE: Replacement receptacles not listed can be found at your local hardware or electrical supply store.

To maintain the factory original performance of your equipment, use only Manufacturer's Suggested Replacement Parts. Model and serial number required when ordering parts from your local distributor.

Processes



Stick (SMAW) Welding

Description



Engine Driven Welding Generator

PARTS LIST

Eff w/LC552237 And Following (Kohler & Honda)

For OM-499 (197 850) Revisions G And H

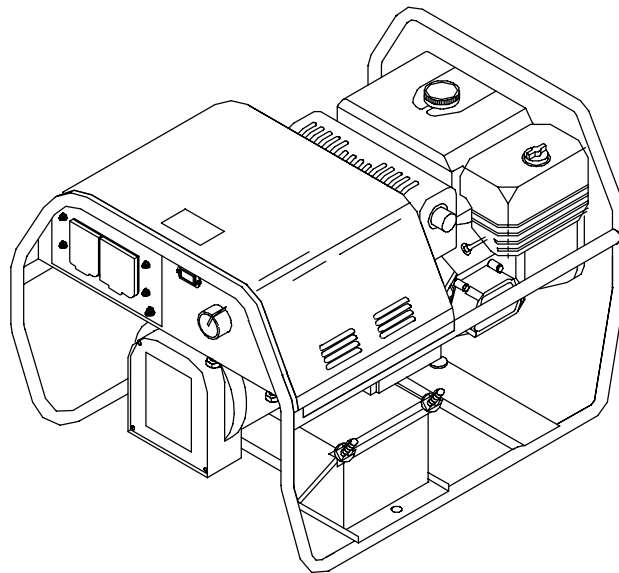

SECTION 16 – PARTS LIST FOR LC552237 AND FOLLOWING

 Hardware is common and not available unless listed.

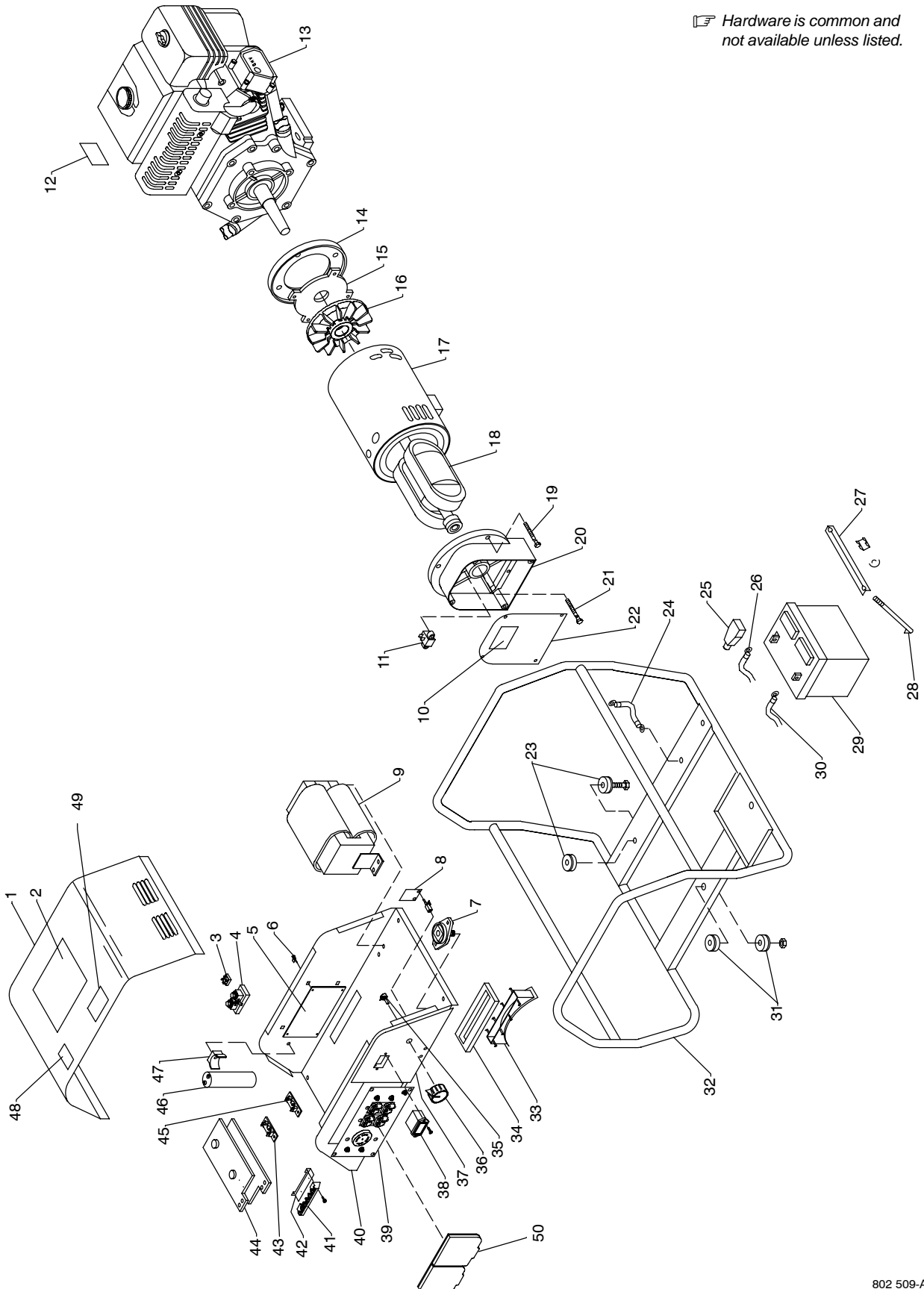

Figure 16-1. Main Assembly

802 509-A

Eff w/LC552237 And Following (Kohler & Honda)

Item No.	Dia. Mkgs.	Part No.	Description	Quantity
Figure 16-1. Main Assembly				
...	1	.. +495 247	.. TOP, control box (specify color)	1
...	2	.. 495 096	.. LABEL, precautionary (Prior to LE130162)	1
...	3	SR1 .. 035 704	.. RECTIFIER, integ bridge 40 A 800V	1
...	4	SHUNT .. 028 747	.. SHUNT, meter	1
...	5	PC1 .. 198 449	.. BOARD, PC assembly	1
...	6	.. 134 201	.. STAND-OFF, support	4
...	7	.. 494 613	.. TERMINAL, output 250V	2
...	7	.. 129 525	.. TERMINAL, output Dinse 50/70 series (European models)	2
...		.. 129 527	.. PLUG, weld cable (European models)	2
...	8	PC2 .. 148 608	.. BOARD, PC filter (CSA only)	1
...	9	L1 .. 198 472	.. REACTOR, stabilizing	1
...	10	.. 204 140	.. LABEL, moving parts (Prior to LE130162)	1
...	10	.. 211 297	.. LABEL, general precautionary (Eff w/LE130162)	1
...	11	.. 493 509	.. BRUSHHOLDER, assembly	1
...	12	.. 204 138	.. LABEL, warning fuel (also supplied with engine)	1
...	13	.. +195 771	.. ENGINE, Kohler 12HP (electric start)	1
...		.. *203 952	.. FILTER, air Kohler cs 8.5 & 12	1
...		.. *203 954	.. FILTER, air pre Kohler cs 8.5 & 12	1
...		.. *203 955	.. CAP, fuel Kohler cs 8.5 & 12	1
...		.. *203 956	.. TANK, fuel Kohler cs 8.5 & 12	1
...		.. *203 957	.. STRAINER, fuel Kohler cs 8.5 & 12	1
...		.. *203 958	.. MUFFLER, exhaust engine Kohler cs 8.5 & 12	1
...		.. *203 959	.. GASKET, muffler Kohler cs 8.5 & 12	1
...		.. *203 960	.. SPARK PLUG, Kohler cs 8.5 & 12	1
...	13	.. +495 055	.. ENGINE, Honda 13HP (recoil start)	1
...	13	.. +495 053	.. ENGINE, Honda 13HP (electric start)	1
...	14	.. 494 606	.. ADAPTER, engine	1
...	15	.. 494 629	.. GUARD, generator	1
...	16	.. 194 509	.. FAN, generator (Kohler)	1
...	16	.. 493 868	.. FAN, generator (Honda)	1
...	17	.. 204 469	.. GENERATOR, w/stator assembly	1
...	18	.. 495 197	.. ROTOR, assembly	1
...		.. 495 154	.. BEARING	1
...	19	.. 495 349	.. SCREW, 1/4-20 HWH	4
...	20	.. 494 587	.. CARRIER, bearing	1
...	21	.. 495 348	.. SCREW, 5/16-24 HWH	1
...	22	.. +494 628	.. PANEL, end generator	1
...	23	.. 495 257	.. MOUNT, shock w/bushing	2
...	24	.. 495 113	.. LEAD, bonding (Prior to LE100004)	1
...	25	.. 494 039	.. COVER, battery cable	1
...	26	.. 495 111	.. LEAD, battery pos	1
...	27	.. 493 057	.. CLAMP, battery	1
...	28	.. 494 604	.. BOLT, hold down	1
...	29 BATTERY, 12V	1
...	30	.. 495 112	.. LEAD, battery neg	1
...	31	.. 495 256	.. MOUNT, shock generator	1
...	32	.. 194 504	.. FRAME, mtg assembly (Kohler)	1
...	32	.. 495 132	.. FRAME, mtg assembly (Honda)	1
...	33	.. 495 255	.. DUCT, air	1
...	34	.. 495 214	.. SEAL, air duct	1
...	35	R1 .. 207 083	.. POTENTIOMETER	1
...	36	.. 207 077	.. KNOB, pointer	1
...	37 NAMEPLATE, overlay (order by model & serial number)	1

Eff w/LC552237 And Following (Kohler & Honda)

Item No.	Dia. Mkgs.	Part No.	Description	Quantity
Figure 16-1. Main Assembly (Continued)				
... 38	HM	176 365	METER, hour	1
... 39		Figure 16-2	PANEL, gen power assembly	1
... 40		495 236	BASE, control box	1
... 41	1T	172 661	BLOCK, terminal	1
... 42		495 193	BRACKET, mtg terminal block	1
... 43	R2/VR1	046 819	SUPPRESSOR, assembly	1
... 44	SR2	495 189	RECTIFIER, assembly (w/mtg hardware)	1
... 45	R3	197 795	RESISTOR ASSEMBLY (Kohler)	1
... 46	C1	176 007	CAPACITOR	1
... 47		494 915	CLAMP, capacitor	1
... 48		201 223	LABEL, warning electric shock power still present (CSA)	1
... 49		495 187	LABEL, current selection	1
... 50		188 039	COVER, receptacle w/gasket	1

*Recommended Spare Parts.

+When ordering a component originally displaying a precautionary label, the label should also be ordered.

To maintain the factory original performance of your equipment, use only Manufacturer's Suggested Replacement Parts. Model and serial number required when ordering parts from your local distributor.

Eff w/LC552237 And Following (Kohler & Honda)

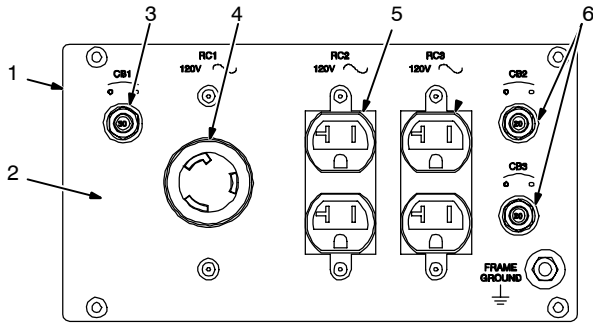

Generator Power Panel 495 218 (USA)

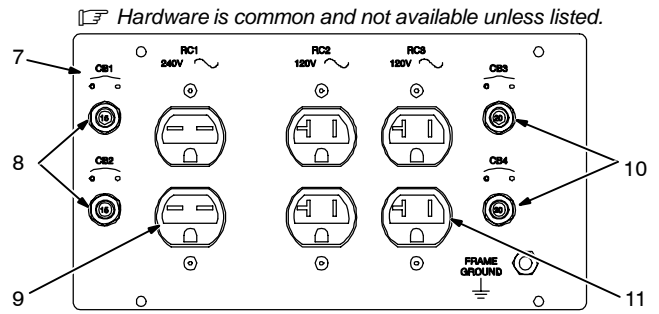

Generator Power Panel 495 315 (USA)

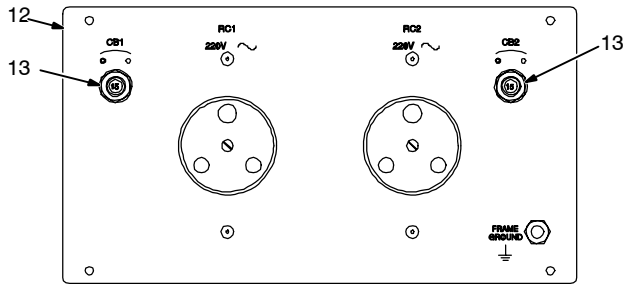

Generator Power Panel 495 253 (South Africa)

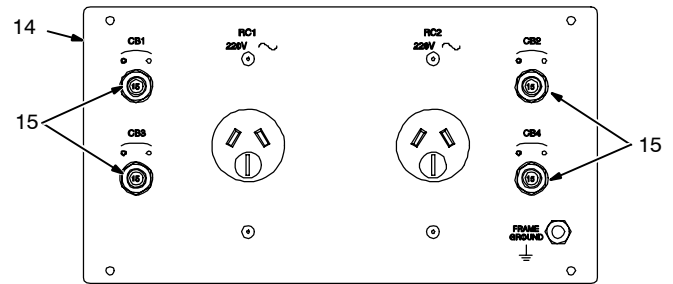

Generator Power Panel 495 289 (Australia)

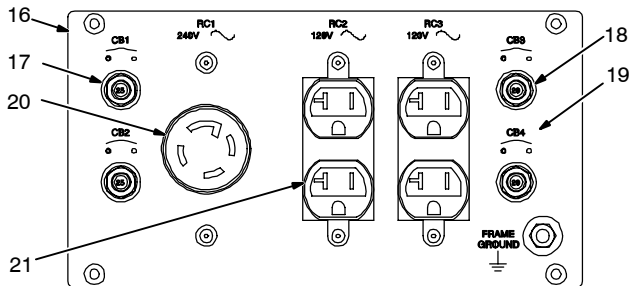

Generator Power Panel 495 219 (USA)

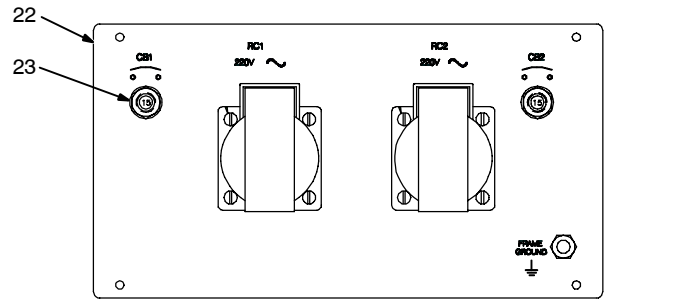

Generator Power Panel 495 290 (Europe)

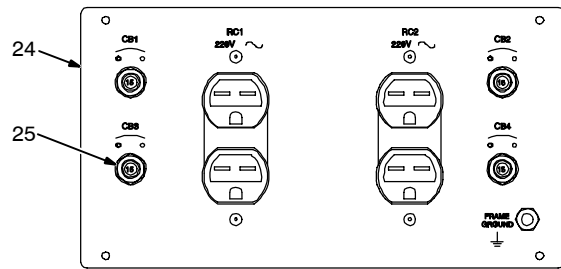

Generator Power Panel 495 288 (S. America)

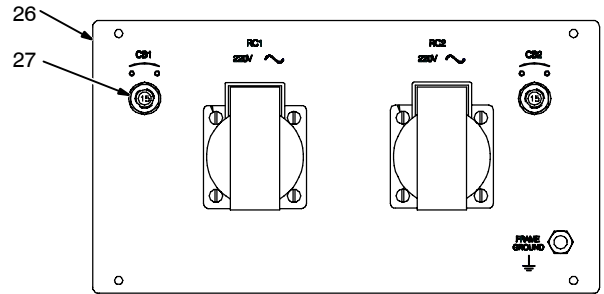

Generator Power Panel 495 283 (S.E. Asia)

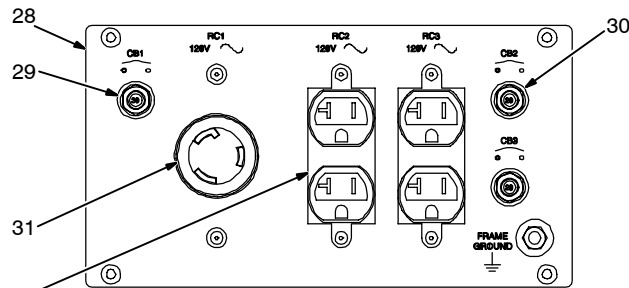

Generator Power Panel 495 298 (USA)

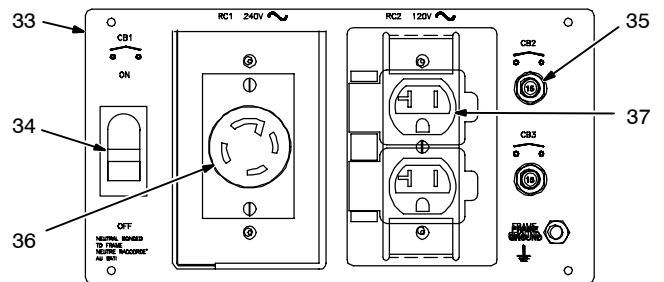

Generator Power Panel 495 278 (Canada-CSA)

Figure 16-2. Generator Power Panels

Eff w/LC552237 And Following (Kohler & Honda)

Item No.	Dia. Mkgs.	Part No.	Description	Quantity
----------	------------	----------	-------------	----------

Figure 16-2. Generator Power Panels (Figure 16-1, Item 39)

Generator Power Panel 495 218 (USA)

...	1	495 220	.. PANEL, generator power assembly	1
...	2	495 216	.. OVERLAY	1
...	3	CB1 495 183	.. CIRCUIT BREAKER, 30A	1
...	4	007 467	.. RECEPTACLE, twistlock grd 2P3W 30A 125 V	1
...	5	408 898	.. RECEPTACLE, duplex 115 V 20 A	2
...	6	CB2, CB3 495 246	.. CIRCUIT BREAKER, 20A	2

Generator Power Panel 495 315 (USA)

...	7	495 314	.. PANEL, generator power assembly	1
...	8	CB1, CB2 495 245	.. CIRCUIT BREAKER, 15A	2
...	9	404 089	.. RECEPTACLE, Duplex 230 V S. American	1
...	10	CB3, CB4 495 246	.. CIRCUIT BREAKER, 20A	2
...	11	408 898	.. RECEPTACLE, Duplex 115 V 20 A U.S.	2

Generator Power Panel 495 253 (South Africa)

...	12	495 252	.. PANEL, generator power assembly	1
...	13	CB1, CB2 495 245	.. CIRCUIT BREAKER, 15A	2

Generator Power Panel 495 289 (Australia)

...	14	495 254	.. PANEL, generator power assembly	1
...	15	CB1 - CB4 495 245	.. CIRCUIT BREAKER, 15A	4

Generator Power Panel 495 219 (USA)

...	16	495 220	.. PANEL, generator power assembly	1
...	17	CB1, CB2 495 182	.. CIRCUIT BREAKER, 25A	2
...	18	CB3, CB4 495 246	.. CIRCUIT BREAKER, 20A	2
...	19	495 217	.. OVERLAY	1
...	20	RC1 129 067	.. RECEPTACLE, tw lk grd 3P4W 30A 125/250V	1
...		088 898	.. PLUG, tw lk grd 3P4W 30A 125/250V	
...	21	RC2, RC3 141 432	.. RECEPTACLE, str dx grd 2P3W 20A 125V	2
...		073 690	.. PLUG, str grd armd 2P3W 15A 125V	

Generator Power Panel 495 290 (Europe)

...	22	495 282	.. PANEL, generator power assembly	1
...	23	CB1, CB2 495 245	.. CIRCUIT BREAKER, 15A	2

Generator Power Panel 495 288 (S. America)

...	24	495 287	.. PANEL, generator power assembly	1
...	25	CB1-4 495 245	.. CIRCUIT BREAKER, 15A	4

Generator Power Panel 495 283 (S.E. Asia)

...	26	495 282	.. Panel, generator power assembly	1
...	27	CB1, CB2 495 245	.. CIRCUIT BREAKER, 15A	2

Generator Power Panel 495 298 (USA)

...	28	495 220	.. PANEL, generator power assembly	1
...	29	CB1 495 183	.. CIRCUIT BREAKER, 30A	1
...	30	CB2, CB3 495 246	.. CIRCUIT BREAKER, 20A	2
...	31	RC1 007 467	.. RECEPTACLE, tw lk grd 2P3W 30A 125V	1
...		605 797	.. PLUG, tw lk 3P3W 20A 125V	
...	32	RC2, RC3 141 432	.. RECEPTACLE, str dx grd 2P3W 20A 125V	2
...		073 690	.. PLUG, str grd armd 2P3W 15A 125V	

Generator Power Panel 495 278 (Canada-CSA)

...	33	495 277	.. PANEL, generator power assembly	1
...	34	CB1 203 095	.. CIRCUIT BREAKER, 25A	1
...		202 631	.. COVER, circuit breaker	1
...		202 630	.. BRACKET, mtg circuit breaker cover	1
...	35	CB2, CB3 495 246	.. CIRCUIT BREAKER, 20A	2
...	36	RC1 129 067	.. RECEPTACLE, tw lk grd 3P4W 30A 125/250V	1
...		088 898	.. PLUG, tw lk grd 3P4W 30A 125/250V	
...	37	RC2 141 432	.. RECEPTACLE, str dx grd 2P3W 20A 125V	1
...		073 690	.. PLUG, str grd armd 2P3W 15A 125V	

NOTE: Replacement receptacles not listed can be found at your local hardware or electrical supply store.

To maintain the factory original performance of your equipment, use only Manufacturer's Suggested Replacement Parts. Model and serial number required when ordering parts from your local distributor.

Miller Electric Mfg. Co.

An Illinois Tool Works Company
1635 West Spencer Street
Appleton, WI 54914 USA

International Headquarters—USA

USA Phone: 920-735-4505 Auto-Attended
USA & Canada FAX: 920-735-4134
International FAX: 920-735-4125

**European Headquarters –
United Kingdom**

Phone: 44 (0) 1204-593493
FAX: 44 (0) 1204-598066



Free Manuals Download Website

<http://myh66.com>

<http://usermanuals.us>

<http://www.somanuals.com>

<http://www.4manuals.cc>

<http://www.manual-lib.com>

<http://www.404manual.com>

<http://www.luxmanual.com>

<http://aubethermostatmanual.com>

Golf course search by state

<http://golfingnear.com>

Email search by domain

<http://emailbydomain.com>

Auto manuals search

<http://auto.somanuals.com>

TV manuals search

<http://tv.somanuals.com>