

# WIRING INSTRUCTIONS

TITLE

**DYMODRILL and SWITCH BOX**

**BULLETIN  
58-03-0020**

MILWAUKEE ELECTRIC TOOL CORP. 13135 WEST LISBON RD. BROOKFIELD, WIS.

DATE  
Oct. '95

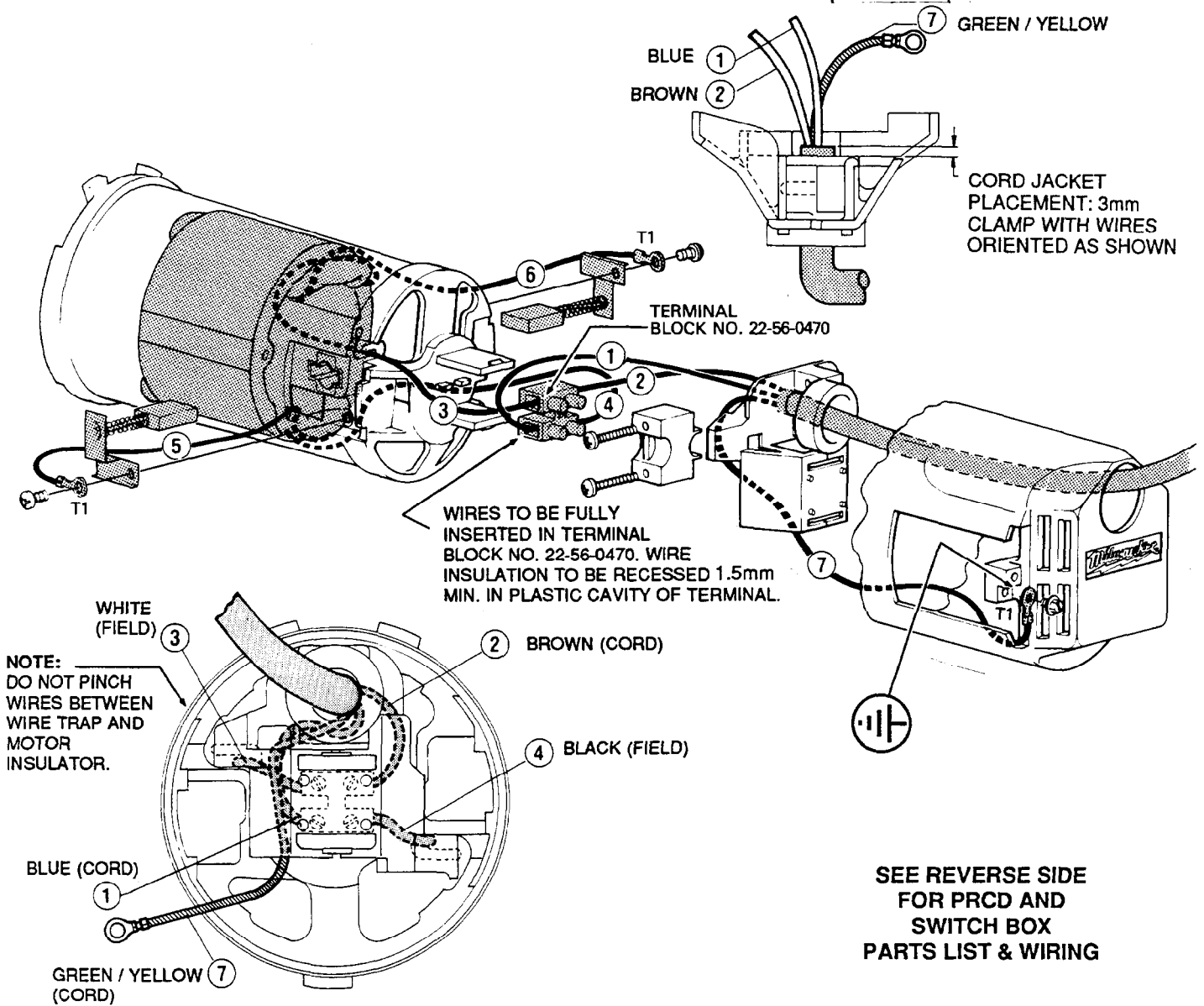

## WIRING SPECIFICATIONS

Wire No.	Wire Color	Origin or Gauge	Length	Terminals, Connectors and 1 or 2 End Wire Preparation
1	BLUE	CORD	70mm	STRIP 6mm
2	BROWN	CORD	70mm	STRIP 6mm
3	WHITE	FIELD	-----	STRIP 6mm
4	BLACK	FIELD	-----	STRIP 6mm
5	WHITE	FIELD	-----	STRIP 5mm FOR T1
6	WHITE	FIELD	-----	STRIP 5mm FOR T1
7	GREEN/YELLOW	CORD	117mm	STRIP 5mm FOR T1

**NOTE:**  
All leads must be held to  $\pm 3$  mm.  
All field leads to be measured from and perpendicular to laminations.  
All lead lengths are before stripping.

## TERMINAL DESCRIPTION

Code	Part No.	Qty.
T1	23-74-0841	3

## CONNECTOR DESCRIPTION

Code	Part No.	Qty.

Drwg. 1

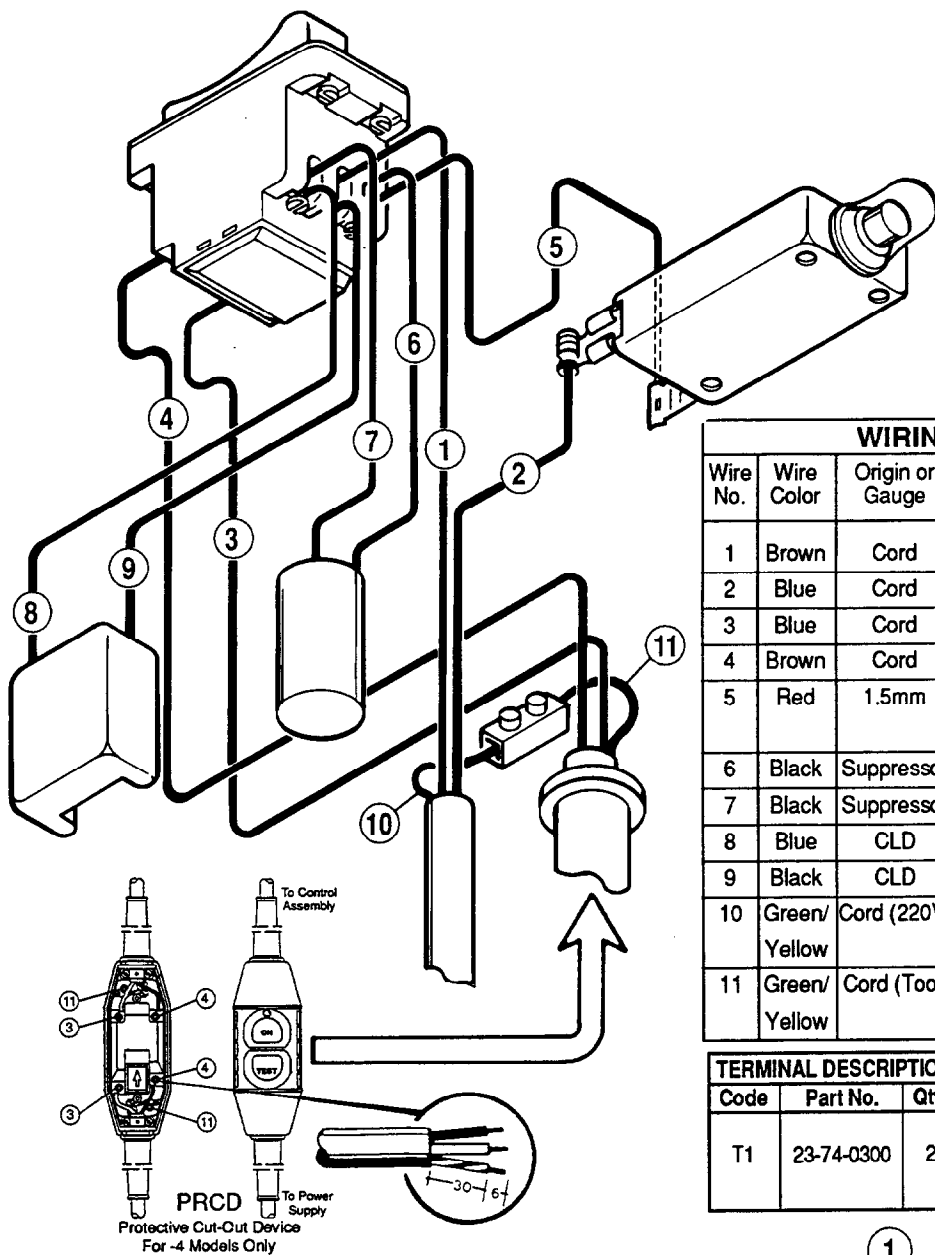

WIRING SPECIFICATIONS				
Wire No.	Wire Color	Origin or Gauge	Length (mm)	Terminals, Connectors and 1 and 2 End Wire Preparation
1	Brown	Cord	133	As Received
2	Blue	Cord	83	As Received
3	Blue	Cord	114	Strip 6mm
4	Brown	Cord	114	Strip 6mm
5	Red	1.5mm	108	Strip 5mm For T1 (One End) Strip 6mm (Other End)
6	Black	Suppressor	As Rec'd.	Strip 6mm
7	Black	Suppressor	As Rec'd.	Strip 6mm
8	Blue	CLD	As Rec'd.	As Received
9	Black	CLD	As Rec'd.	As Received
10	Green/ Yellow	Cord (220V)	38	Strip 6mm
11	Green/ Yellow	Cord (Tool)	38	Strip 6mm

TERMINAL DESCRIPTION		
Code	Part No.	Qty.
T1	23-74-0300	2

**NOTE:**  
All lengths must be held to  $\pm 3$ mm.  
All field leads to be measured from and perpendicular to laminations. All lead lengths are before stripping.

Fig.	Part Number	Description	No. Req.
1	22-68-0200	Switch Boot	1
2	23-66-1430	Switch	1
3	23-94-9915	Connector Lead	1
4	22-36-0150	Breaker	1
5	22-68-0210	Breaker Boot	1
6	22-33-0305	Suppressor	1
7	22-74-0050	Delay Circuit (CLD)	1
8	22-12-0200	Enclosure	1
9	06-82-7299	Screw	4
10	31-17-0155	Clamp	2
11	44-76-0140	Strain Relief	1
12	22-64-4075	Cord Set (220 V)	1
13	22-68-0190	Cover	1
14	12-98-3070	Instruction Plate	1
15	22-64-4085	Cord Set (Tool)	1
16	06-82-7326	Screw	4
17	22-56-0480	Terminal Block	1

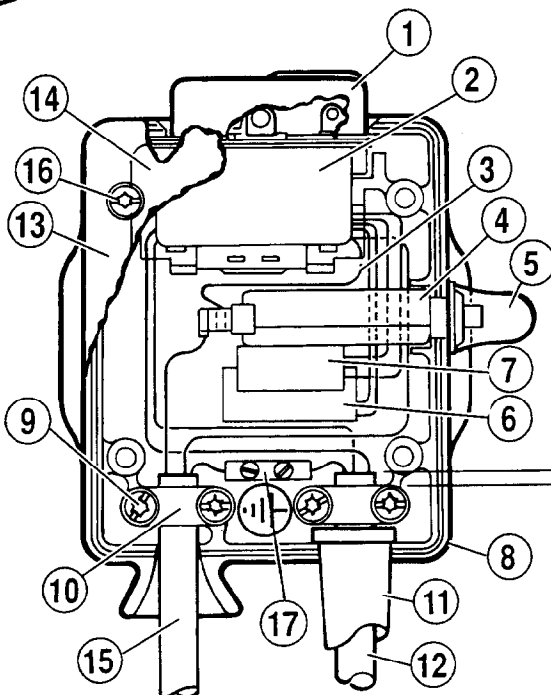

**NOTE:**  
Cover should mate flush with enclosure before driving the 4 cover screws. A gap indicates a misplaced wire or component.

Tighten breaker boot after installing cover.

Extend cord jacket 9mm past clamp. (2 places)

## Free Manuals Download Website

<http://myh66.com>

<http://usermanuals.us>

<http://www.somanuals.com>

<http://www.4manuals.cc>

<http://www.manual-lib.com>

<http://www.404manual.com>

<http://www.luxmanual.com>

<http://aubethermostatmanual.com>

Golf course search by state

<http://golfingnear.com>

Email search by domain

<http://emailbydomain.com>

Auto manuals search

<http://auto.somanuals.com>

TV manuals search

<http://tv.somanuals.com>