

**Milwaukee**

**HEAVY-DUTY  
ELECTRIC TOOLS**



**AG 750-100  
AG 750-125**



**Original Instructions**







16



14

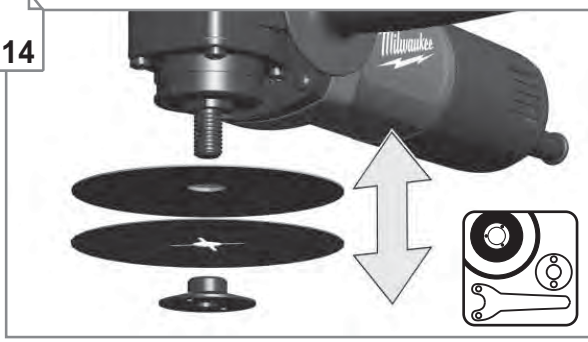

10

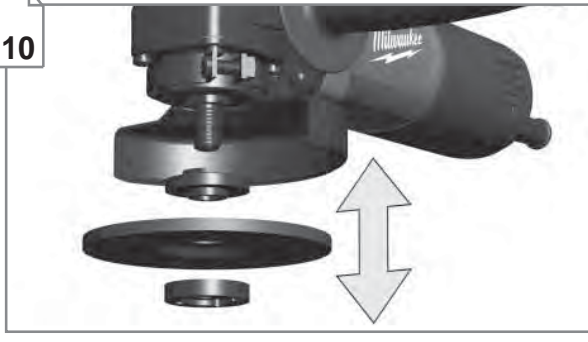

6



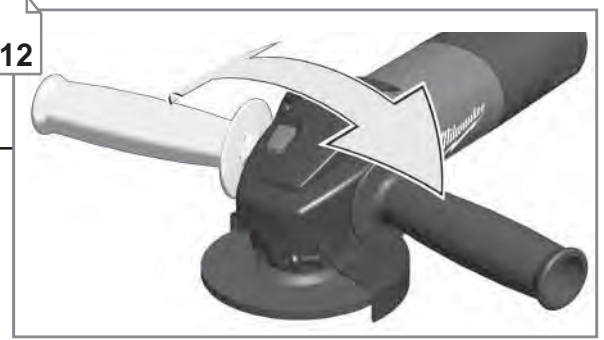
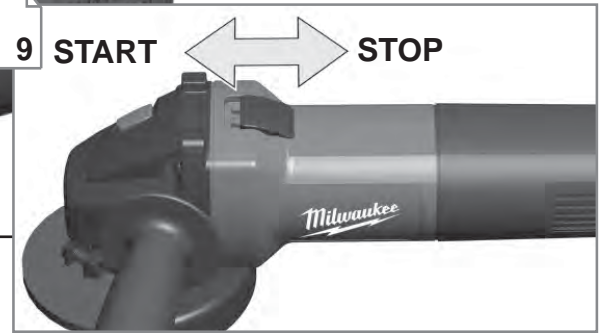
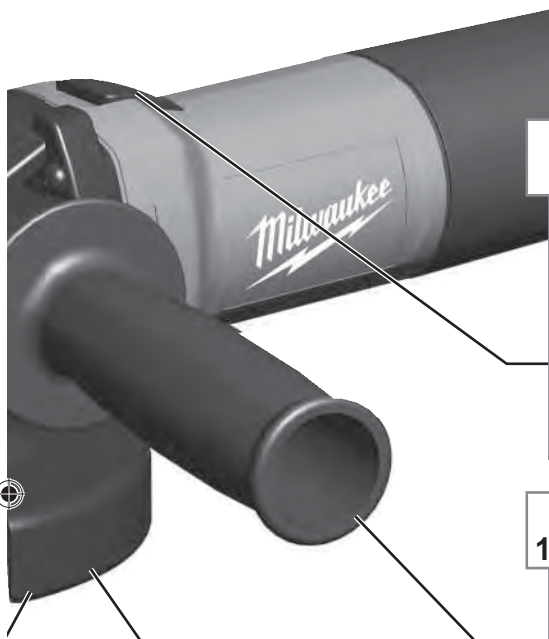



# 1

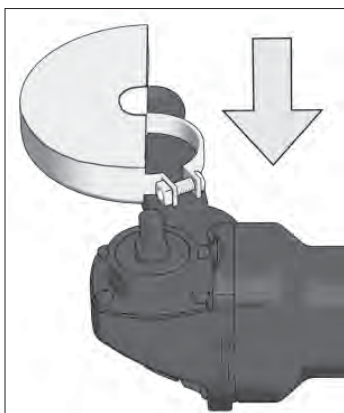
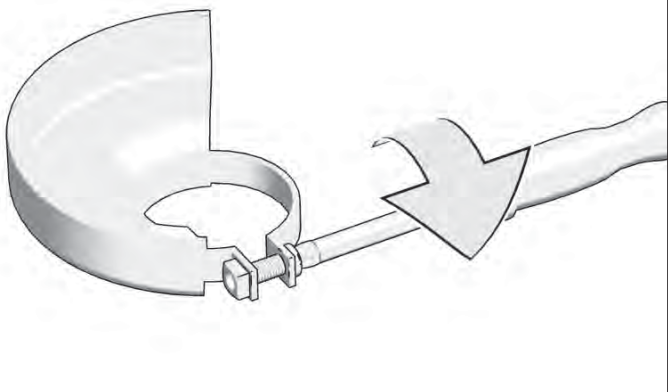

For cutting off operation!

# 2

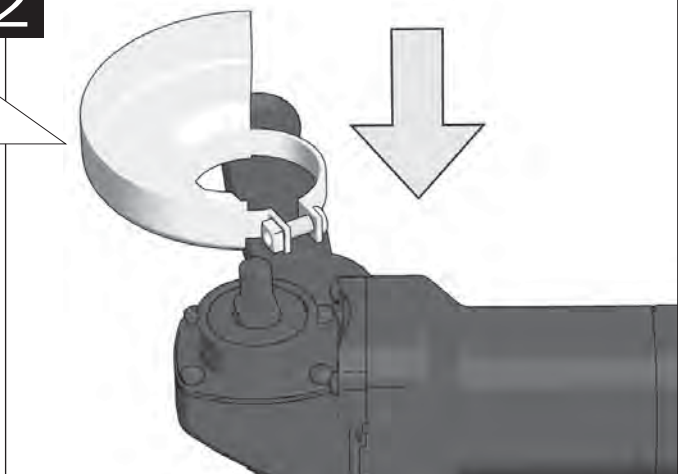

# 6



3

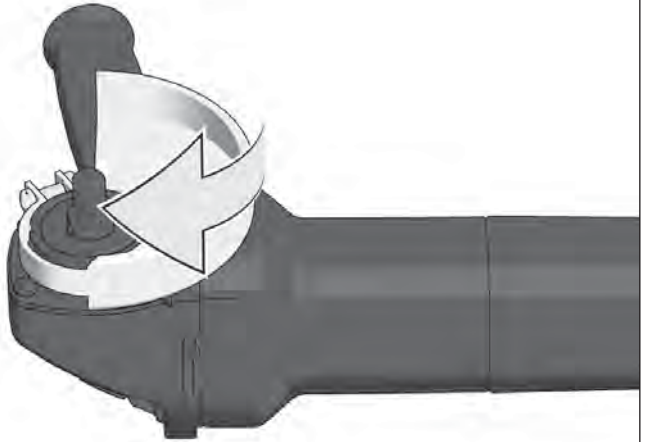

4

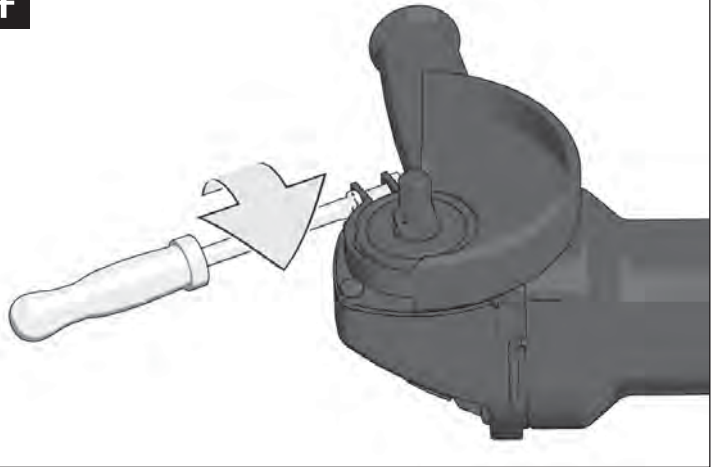



**A**

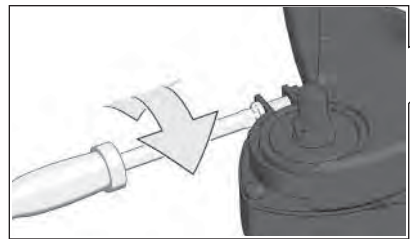

**B**

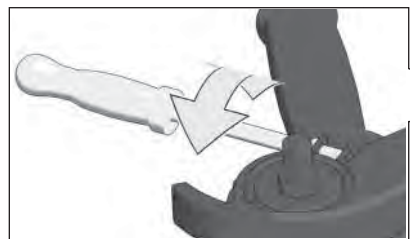
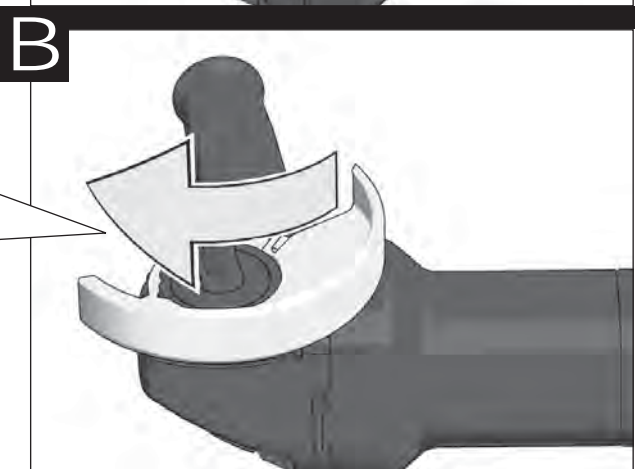

**C**

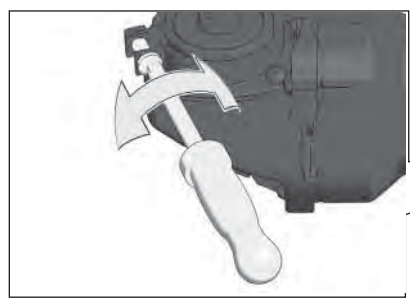
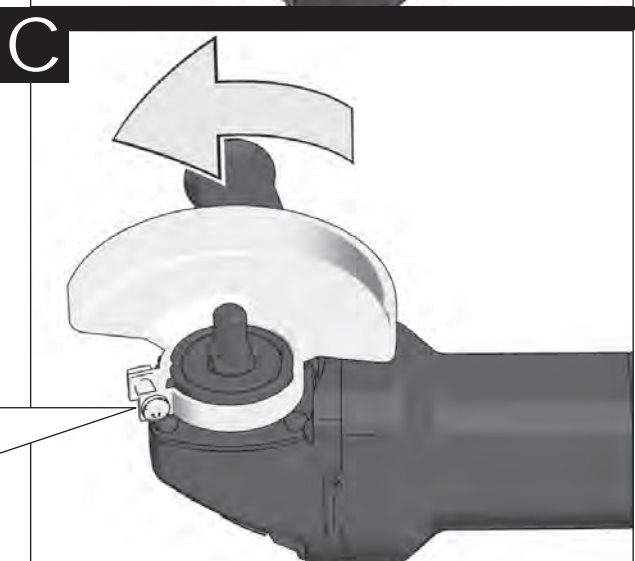





# START



# STOP



# START/LOCK

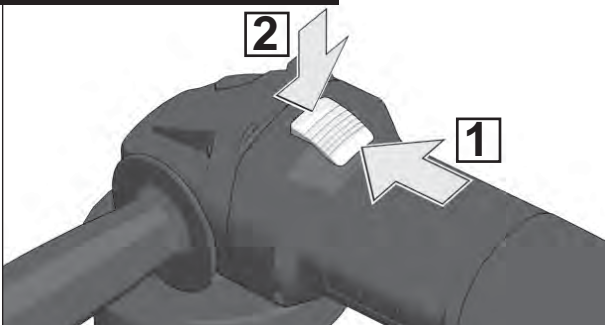

# STOP

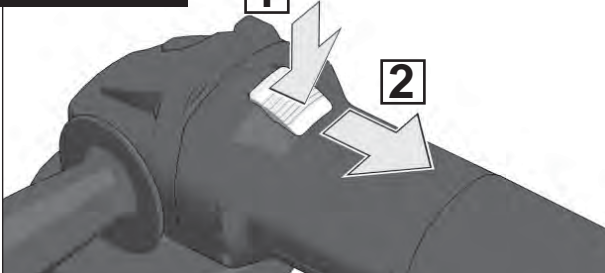

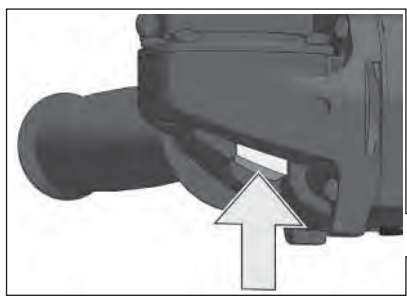
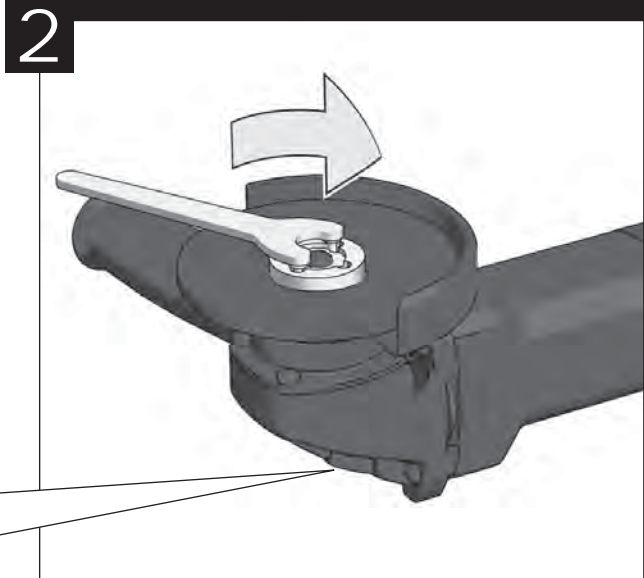
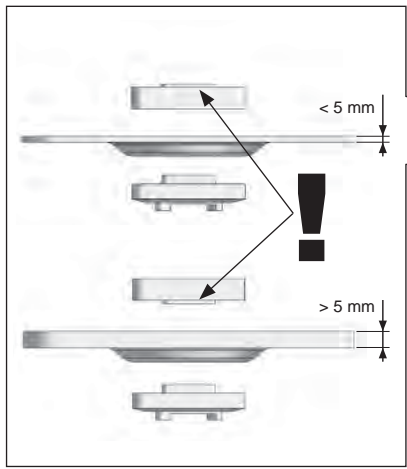
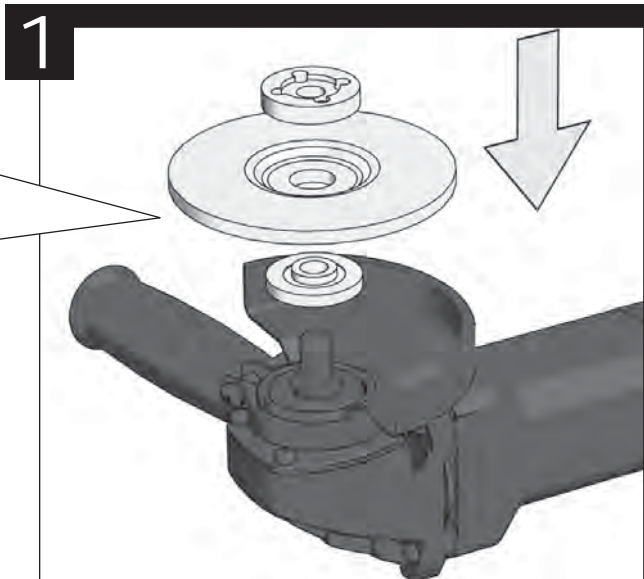



1

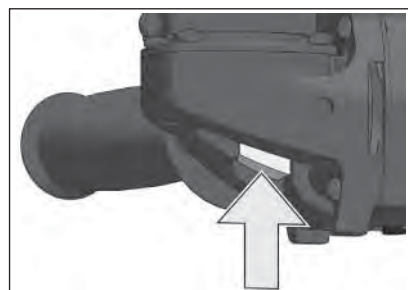
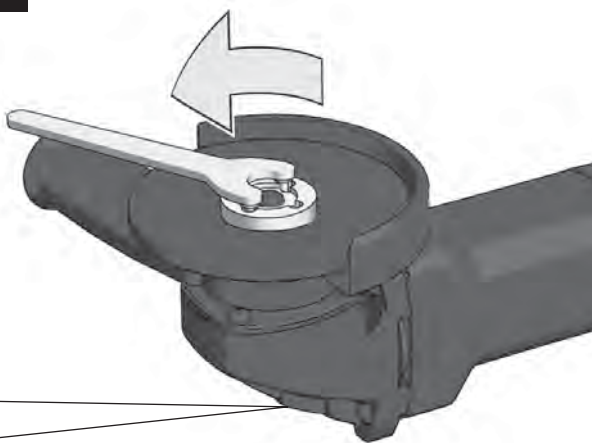

2

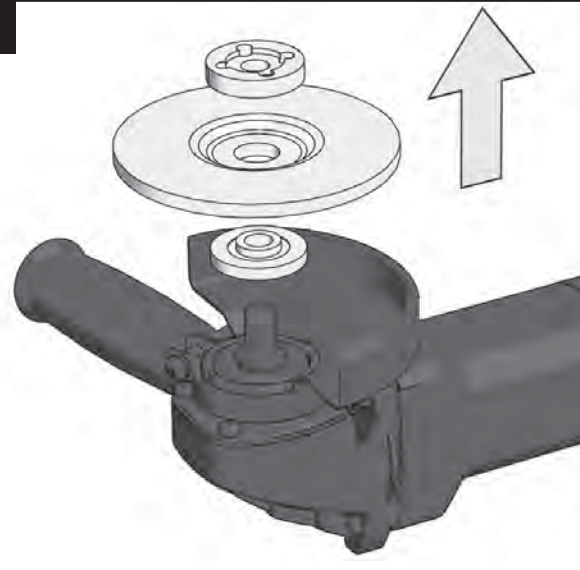

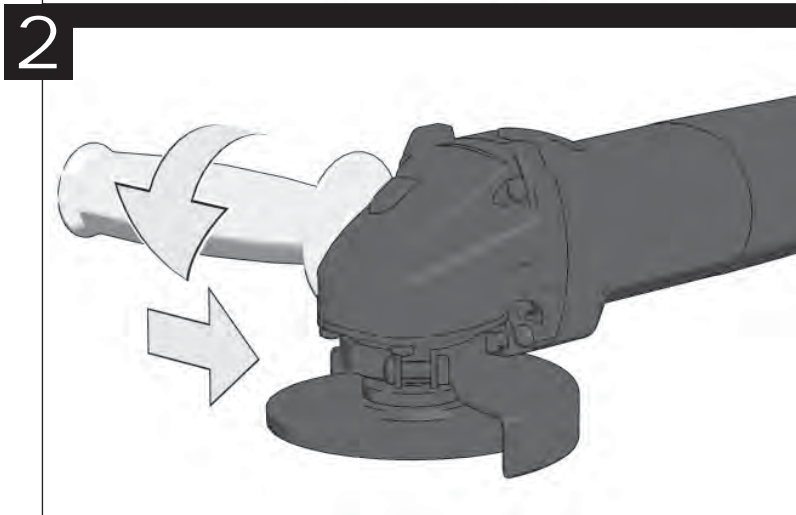
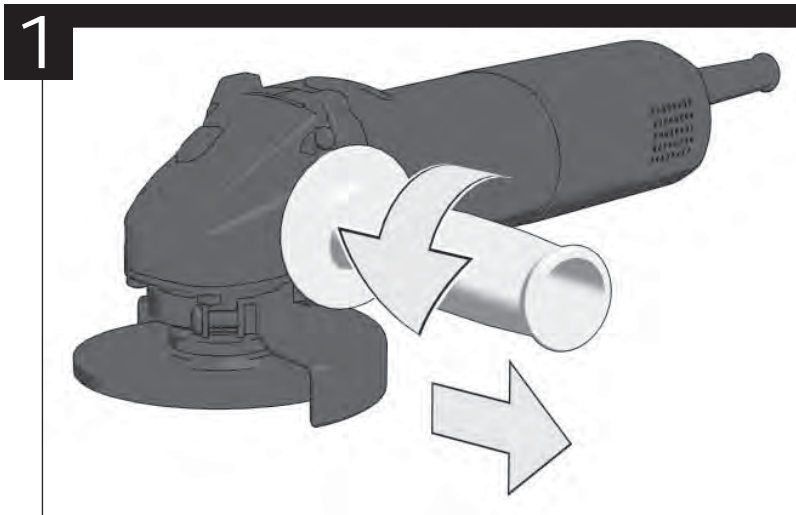

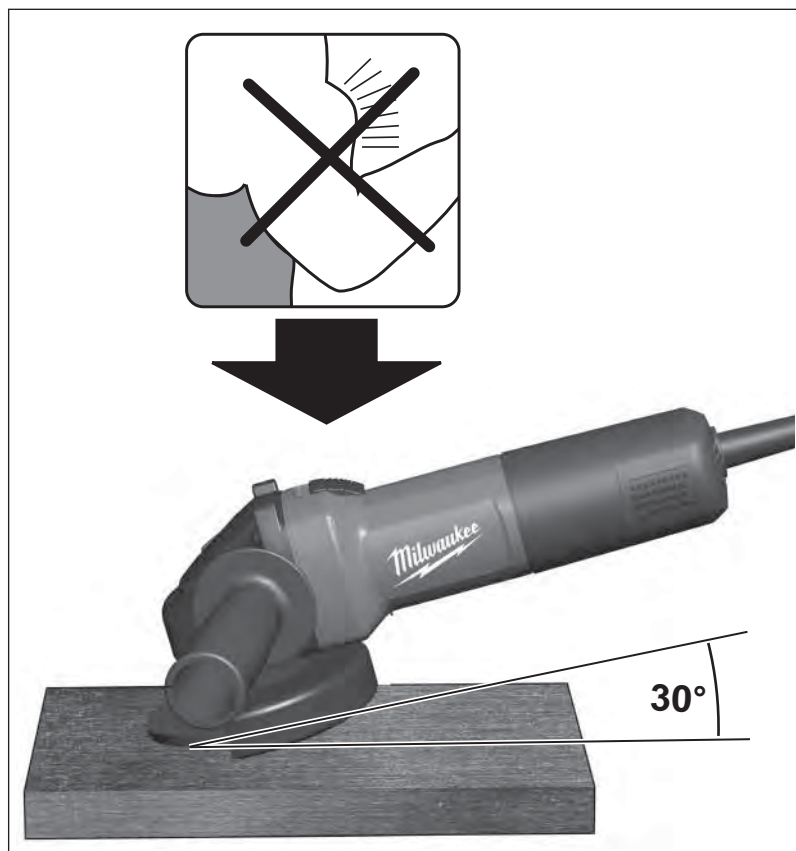



Accessory



1

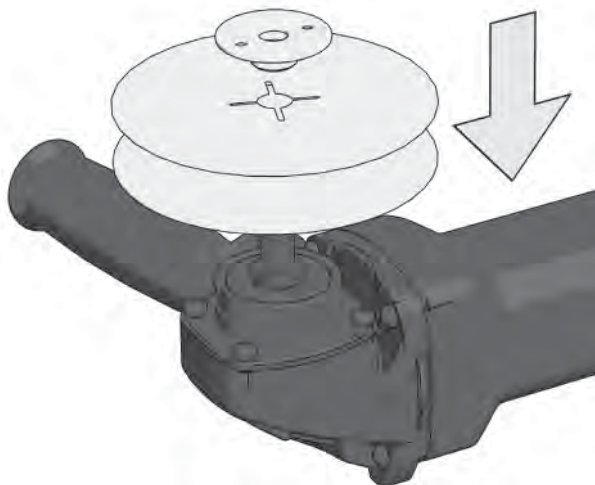

2

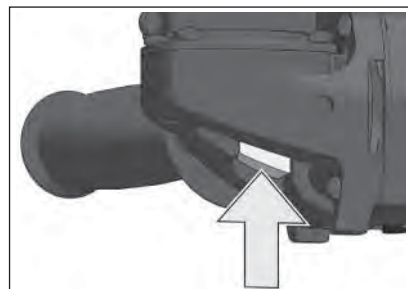
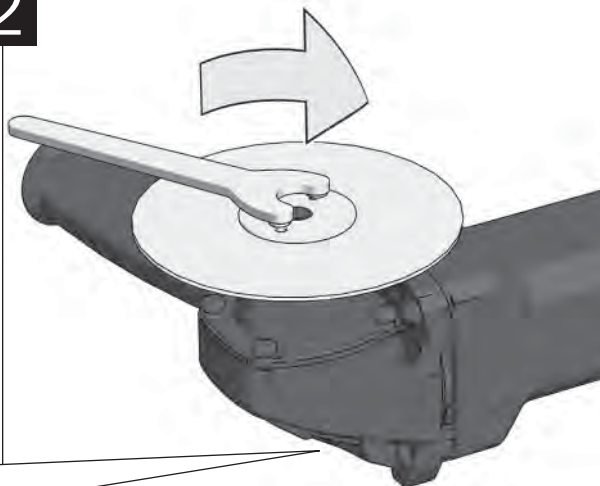

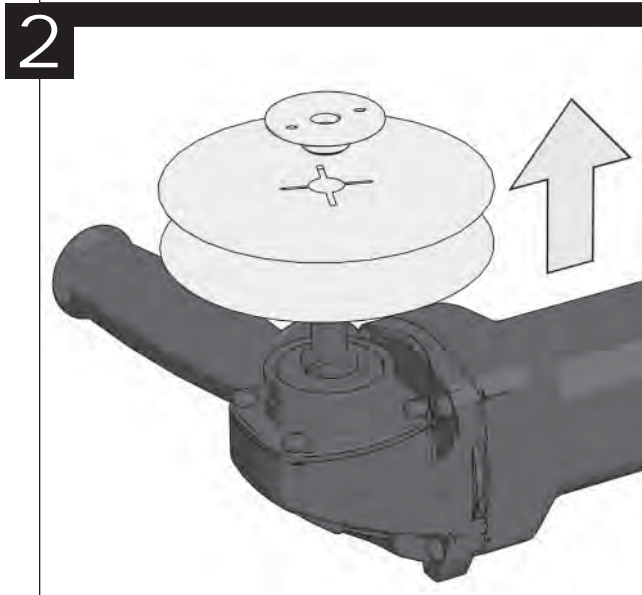
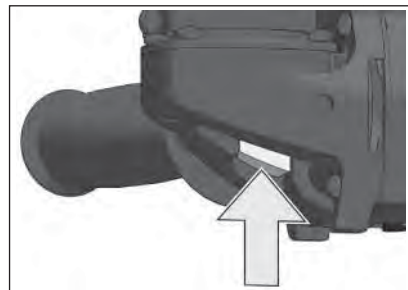
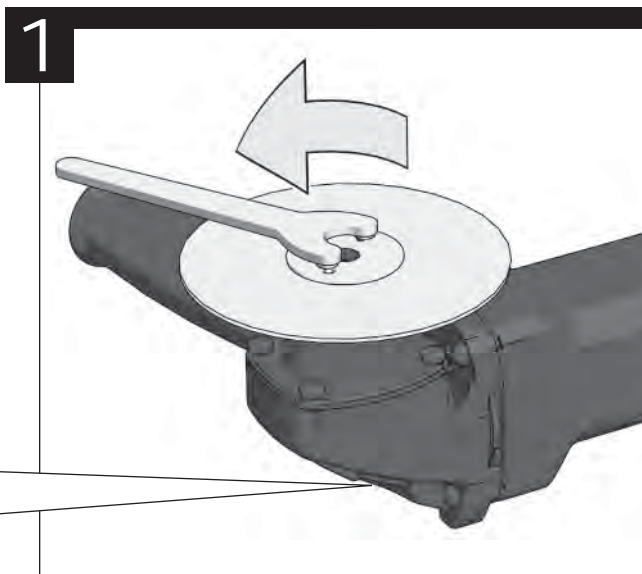
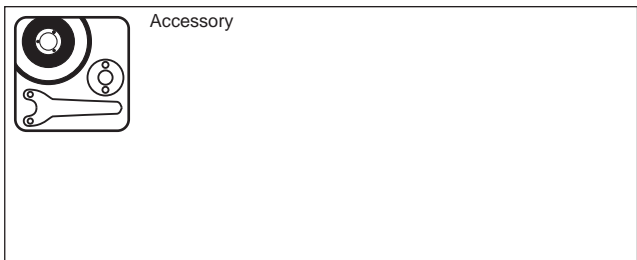

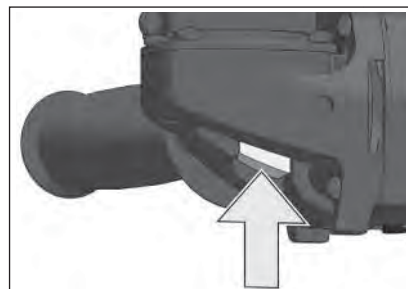
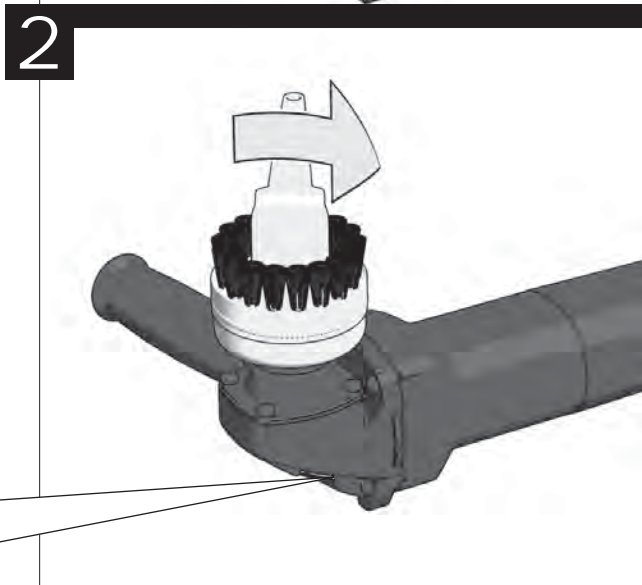
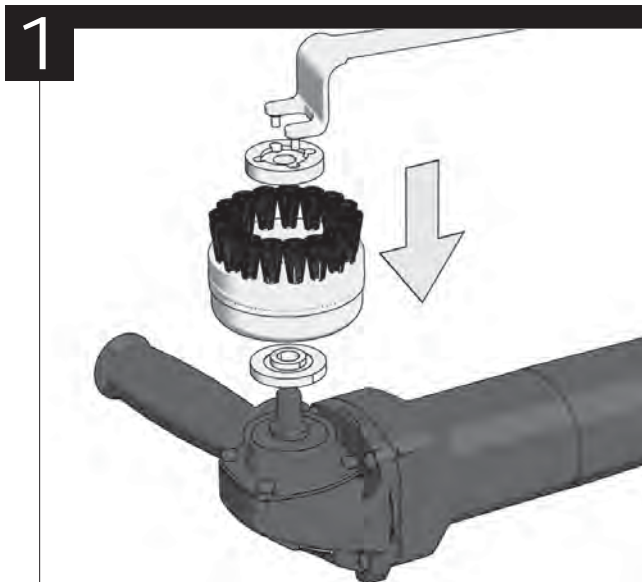



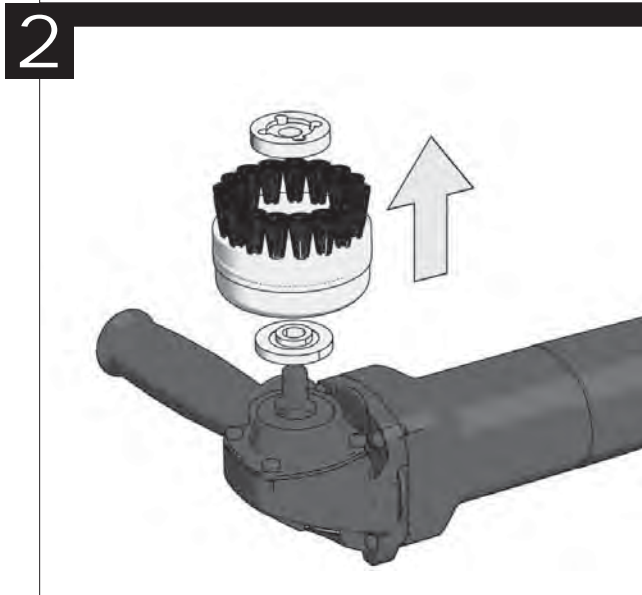
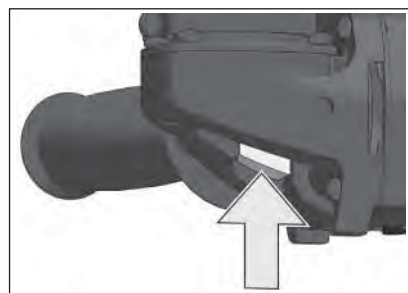
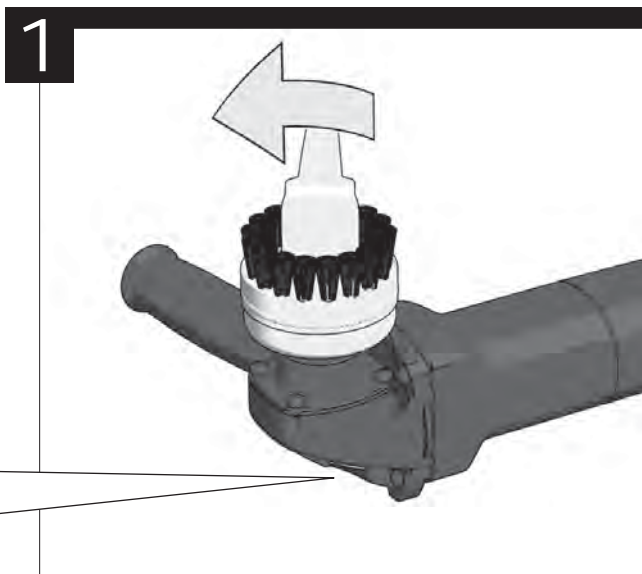

**TECHNICAL DATA****AG 750-100****AG 750-125**

Rated input.....	750 W.....	750 W
Max. no-load speed.....	10000 (min <sup>-1</sup> ).....	10000 (min <sup>-1</sup> )
Grinding disk diameter.....	100 mm.....	125 mm
Thread of work spindle.....	M 10.....	M 14
Weight without cable.....	1,8 kg.....	1,8 kg

**Noise/Vibration Information**

Measured values determined according to EN 60745. Typically, the A-weighted noise levels of the tool are:

Sound pressure level (K=3 dB(A)).....	82 dB(A).....	87,1 dB(A)
Sound power level (K=3 dB(A)).....	93 dB(A).....	98,1 dB(A)

**Wear ear protection!**

Total vibration values (vector sum in the three axes) determined according to EN 60745:

Surface grinding: vibration emission value $a_h$ .....	6,8 m/s <sup>2</sup> .....	6,8 m/s <sup>2</sup>
Uncertainty K =.....	1,5 m/s <sup>2</sup> .....	1,5 m/s <sup>2</sup>
Disk sanding vibration emission value $a_h$ .....	3,5 m/s <sup>2</sup> .....	3,5 m/s <sup>2</sup>
Uncertainty K =.....	1,5 m/s <sup>2</sup> .....	1,5 m/s <sup>2</sup>

For other applications, e.g.

Wire Brushing other vibration values could occur.

**WARNING**

The vibration emission level given in this information sheet has been measured in accordance with a standardised test given in EN 60745 and may be used to compare one tool with another. It may be used for a preliminary assessment of exposure.

The declared vibration emission level represents the main applications of the tool. However if the tool is used for different applications, with different accessories or poorly maintained, the vibration emission may differ. This may significantly increase the exposure level over the total working period.

An estimation of the level of exposure to vibration should also take into account the times when the tool is switched off or when it is running but not actually doing the job. This may significantly reduce the exposure level over the total working period.

Identify additional safety measures to protect the operator from the effects of vibration such as: maintain the tool and the accessories, keep the hands warm, organisation of work patterns.

**⚠ WARNING! Read all safety warnings and all instructions, including those given in the accompanying brochure.** Failure to follow the warnings and instructions may result in electric shock, fire and/or serious injury. **Save all warnings and instructions for future reference.**

**SAFETY INSTRUCTIONS****Safety Warnings Common for Grinding, Sanding, Wire Brushing Operations:**

**a) This power tool is intended to function as a grinder, sander, wire brush. Read all safety warnings, instructions, illustrations and specifications provided with this power tool.** Failure to follow all instructions listed below may result in electric shock, fire and/or serious injury.

**b) Operations as polishing are not recommended to be performed with this power tool.** Operations for which the power tool was not designed may create a hazard and cause personal injury.

**c) Do not use accessories which are not specifically designed and recommended by the tool manufacturer.** Just because the accessory can be attached to your power tool, it does not assure safe operation.

**d) The rated speed of the accessory must be at least equal to the maximum speed marked on the power tool.** Accessories running faster than their rated speed can break and fly apart.

**e) The outside diameter and the thickness of your accessory must be within the capacity rating of your power tool.** Incorrectly sized accessories cannot be adequately guarded or controlled.

**f) The arbour size of wheels, flanges, backing pads or any other accessory must properly fit the spindle of the power tool.** Accessories with arbour holes that do not match the mounting hardware of the power tool will run out of balance, vibrate excessively and may cause loss of control.

**g) Do not use a damaged accessory. Before each use inspect the accessory such as abrasive wheels for chips**

**and cracks, backing pad for cracks, tear or excess wear, wire brush for loose or cracked wires. If power tool or accessory is dropped, inspect for damage or install an undamaged accessory. After inspecting and installing an accessory, position yourself and bystanders away from the plane of the rotating accessory and run the power tool at maximum no-load speed for one minute.** Damaged accessories will normally break apart during this test time.

**h) Wear personal protective equipment. Depending on application, use face shield, safety goggles or safety glasses. As appropriate, wear dust mask, hearing protectors, gloves and shop apron capable of stopping small abrasive or workpiece fragments.** The eye protection must be capable of stopping flying debris generated by various operations. The dust mask or respirator must be capable of filtering particles generated by your operation. Prolonged exposure to high intensity noise may cause hearing loss.

**i) Keep bystanders a safe distance away from work area. Anyone entering the work area must wear personal protective equipment.** Fragments of workpiece or of a broken accessory may fly away and cause injury beyond immediate area of operation.

**j) Hold power tool by insulated gripping surfaces only, when performing an operation where the cutting accessory may contact hidden wiring or its own cord.** Cutting accessory contacting a „live“ wire may make exposed metal parts of the power tool „live“ and shock the operator.

**k) Position the cord clear of the spinning accessory.** If you lose control, the cord may be cut or snagged and your hand or arm may be pulled into the spinning accessory.

**l) Never lay the power tool down until the accessory has come to a complete stop.** The spinning accessory may grab the surface and pull the power tool out of your control.

**m) Do not run the power tool while carrying it at your side.** Accidental contact with the spinning accessory could snag your clothing, pulling the accessory into your body.

**n) Regularly clean the power tool's air vents.** The motor's fan will draw the dust inside the housing and excessive



accumulation of powdered metal may cause electrical hazards.

**o) Do not operate the power tool near flammable materials.** Sparks could ignite these materials.

**p) Do not use accessories that require liquid coolants.** Using water or other liquid coolants may result in electrocution or shock.

### Kickback and Related Warnings

Kickback is a sudden reaction to a pinched or snagged rotating wheel, backing pad, brush or any other accessory. Pinching or snagging causes rapid stalling of the rotating accessory which in turn causes the uncontrolled power tool to be forced in the direction opposite of the accessory's rotation at the point of the binding.

For example, if an abrasive wheel is snagged or pinched by the workpiece, the edge of the wheel that is entering into the pinch point can dig into the surface of the material causing the wheel to climb out or kick out. The wheel may either jump toward or away from the operator, depending on direction of the wheel's movement at the point of pinching. Abrasive wheels may also break under these conditions.

Kickback is the result of power tool misuse and/or incorrect operating procedures or conditions and can be avoided by taking proper precautions as given below.

**a) Maintain a firm grip on the power tool and position your body and arm to allow you to resist kickback forces. Always use auxiliary handle, if provided, for maximum control over kickback or torque reaction during start-up.** The operator can control torque reactions or kickback forces, if proper precautions are taken.

**b) Never place your hand near the rotating accessory.** Accessory may kickback over your hand.

**c) Do not position your body in the area where power tool will move if kickback occurs.** Kickback will propel the tool in direction opposite to the wheel's movement at the point of snagging.

**d) Use special care when working corners, sharp edges etc. Avoid bouncing and snagging the accessory.** Corners, sharp edges or bouncing have a tendency to snag the rotating accessory and cause loss of control or kickback.

**e) Do not attach a saw chain, woodcarving blade or toothed saw blade.** Such blades create frequent kickback and loss of control.

### Safety Warnings Specific for Grinding Operations:

**a) Use only wheel types that are recommended for your power tool and the specific guard designed for the selected wheel.** Wheels for which the power tool was not designed cannot be adequately guarded and are unsafe.

**b) The guard must be securely attached to the power tool and positioned for maximum safety, so the least amount of wheel is exposed towards the operator.** The guard helps to protect operator from broken wheel fragments and accidental contact with wheel.

**c) Wheels must be used only for recommended applications. For example: do not grind with the side of cut-off wheel.** Abrasive cut-off wheels are intended for peripheral grinding, side forces applied to these wheels may cause them to shatter.

**d) Always use undamaged wheel flanges that are of correct size and shape for your selected wheel.** Proper wheel flanges support the wheel thus reducing the possibility of wheel breakage. Flanges for cut-off wheels may be different from grinding wheel flanges.

**e) Do not use worn down wheels from larger power tools.** Wheel intended for larger power tool is not suitable for the higher speed of a smaller tool and may burst.

### Safety Warnings Specific for Sanding Operations:

**a) Do not use excessively oversized sanding disc paper. Follow manufacturers recommendations, when selecting sanding paper.** Larger sanding paper extending beyond the sanding pad presents a laceration hazard and may cause snagging, tearing of the disc or kickback.

### Safety Warnings Specific for Wire Brushing Operations:

**a) Be aware that wire bristles are thrown by the brush even during ordinary operation. Do not overstress the wires by applying excessive load to the brush.** The wire bristles can easily penetrate light clothing and/or skin.

**b) If the use of a guard is recommended for wire brushing, do not allow any interference of the wire wheel or brush with the guard.** Wire wheel or brush may expand in diameter due to work load and centrifugal forces.

Appliances used at many different locations including open air should be connected via a residual current device of 30 mA or less.

Dust and splinters must not be removed while the machine is running.

Only plug-in when machine is switched off.

Never reach into the danger area of the tool when it is running.

Always use the auxiliary handle.

Immediately switch off the machine in case of considerable vibrations or if other malfunctions occur. Check the machine in order to find out the cause.

Always use and store the grinding disks according to the manufacturer's instructions.

When grinding metal, flying sparks are produced. Take care that no persons are endangered. Because of the danger of fire, no combustible materials should be located in the vicinity (spark flight zone). Do not use dust extraction.

Due care should be taken that no sparks or sanding dust flying from the workpiece come into contact with you.

When separating stone the guide shoe must be used!

The adjusting nut must be tightened before starting to work with the machine.

The workpiece must be fixed if it is not heavy enough to be steady. Never lead the workpiece to the grinding disk with your hand.

Under extreme conditions (e.g. smooth-grinding metals with the arbour and vulcanized fibre grinding wheel), significant contamination can build up on the inside of the angle grinder. For safety reasons, in such conditions the inside should be cleaned thoroughly of metal deposits and a motor circuit-breaker must be connected in series. If the motor circuit-breaker trips the machine must be sent for repair.

For accessories intended to be fitted with threaded hole wheel, ensure that the thread in the wheel is long enough to accept the spindle length.

For cutting or separating use a closed protection cap, available as an accessory.

### SPECIFIED CONDITIONS OF USE

The angle grinder can be used to rough-grind many different materials, e.g. metal or stone, for grinding with a plastic grinding plate and for operation with the wire brush.

Always follow the manufacturer's instructions if you are unsure about anything to do with the machine.

Do not use this product in any other way as stated for normal use.

## MAINS CONNECTION

Connect only to single-phase a.c. current and only to the system voltage indicated on the rating plate. It is also possible to connect to sockets without an earthing contact as the design conforms to safety class II.

## MAINTENANCE

The ventilation slots of the machine must be kept clear at all times.

Use only Milwaukee accessories and spare parts. Should components need to be exchanged which have not been described, please contact one of our Milwaukee service agents (see our list of guarantee/service addresses).

If needed, an exploded view of the tool can be ordered. Please state the ten-digit No. as well as the machine type printed on the label and order the drawing at your local service agents or directly at: Milwaukee Electric Tool, Max-Eyth-Straße 10, D-71364 Winnenden, Germany.

## SYMBOLS



Please read the instructions carefully before starting the machine.



Always wear goggles when using the machine.



Always disconnect the plug from the socket before carrying out any work on the machine.



Accessory - Not included in standard equipment, available as an accessory.



Do not dispose of electric tools together with household waste material! In observance of European Directive 2002/96/EC on waste electrical and electronic equipment and its implementation in accordance with national law, electric tools that have reached the end of their life must be collected separately and returned to an environmentally compatible recycling facility.



Made in China  
Copyright 2009  
Milwaukee Electric Tool  
Max-Eyth-Straße 10  
D-71364 Winnenden  
Germany  
+49 (0) 7195-12-0



(11.09)

**4931 4140 32**

## Free Manuals Download Website

<http://myh66.com>

<http://usermanuals.us>

<http://www.somanuals.com>

<http://www.4manuals.cc>

<http://www.manual-lib.com>

<http://www.404manual.com>

<http://www.luxmanual.com>

<http://aubethermostatmanual.com>

Golf course search by state

<http://golfingnear.com>

Email search by domain

<http://emailbydomain.com>

Auto manuals search

<http://auto.somanuals.com>

TV manuals search

<http://tv.somanuals.com>