



SERVICE PARTS LIST

SPECIFY CATALOG NO. AND SERIAL NO. WHEN ORDERING PARTS		REVISED BULLETIN	DATE
ANGLED FINISH NAILER			Jan. 2009
CATALOG NO. 7140-21	STARTING SERIAL NUMBER	A88A	
		WIRING INSTRUCTION	

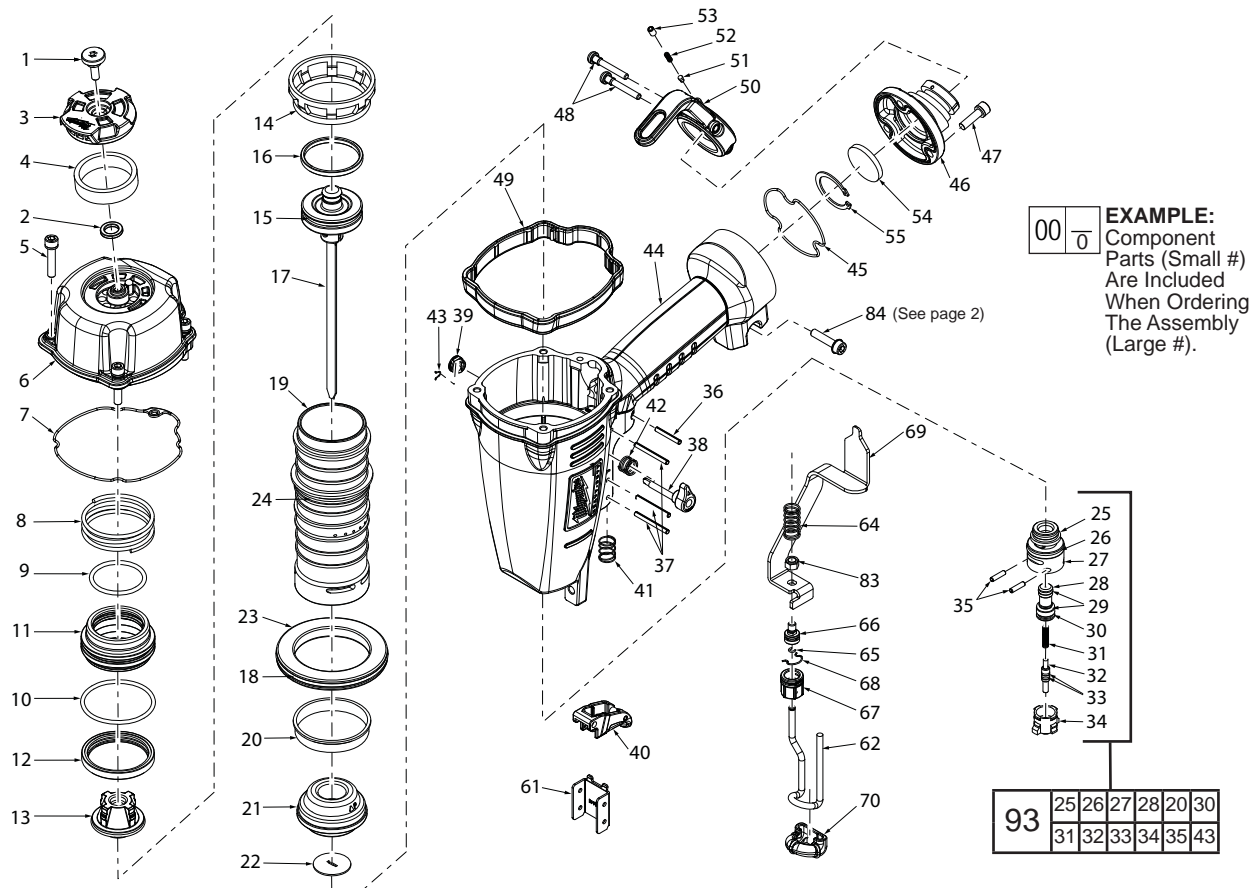

FIG.	PART NO.	DESCRIPTION OF PART	NO. REQ.	FIG.	PART NO.	DESCRIPTION OF PART	NO. REQ.
1	05-84-0805	Deflector Bolt	1	36	06-65-1420	Spring Pin	2
2	45-88-1720	Deflector Pad	1	37	06-65-1440	Spring Pin	3
3	31-05-0400	Deflector	1	38	44-10-0650	Selector	1
4	43-31-0355	Muffler	1	39	44-86-0710	Retainer	1
5	05-84-0845	Bolt Assembly	4	40	31-92-0200	Trigger Assembly	1
6	42-92-1435	Top Cap	1	41	40-50-3160	Spring	1
7	45-06-0920	Seal	1	42	40-50-3095	Selector Spring	1
8	40-50-3120	Upper Valve Spring	1	43	44-90-0825	Ring	1
9	34-40-3195	O-Ring	1	44	28-50-0815	Tool Body	1
10	34-40-3245	O-Ring	1	45	43-44-1255	Gasket	1
11	44-62-0265	Head Valve Piston	1	46	42-92-1365	End Cap	1
12	42-76-0815	Valve Collar	1	47	05-84-0830	Bolt Assembly	1
13	45-06-0950	Seal	1	48	05-83-0525	Round Head Phillips Bolt	2
14	44-90-0700	Press Ring	1	49	42-38-0380	Bumper Band	1
15	34-40-3180	O-Ring	1	50	42-70-0400	Spring Retainer (Belt Clip)	1
16	44-90-0730	Piston Ring	1	51	45-08-0460	Positioning Shaft	1
17	43-12-0270	Driver Assembly	1	52	40-50-3185	Positioning Spring	1
18	34-40-3200	O-Ring	1	53	05-84-0950	Socket Hex Head Screw	1
19	42-98-0370	Cylinder	1	54	43-31-0370	Filter	1
20	44-90-0805	Cylinder Spacer	1	55	44-90-0785	Snap Ring	1
21	42-38-0315	Bumper	1	61	43-56-0880	Work Contact Element Guide	1
22	43-56-0900	Driver Guide	1	62	42-36-2030	Work Contact Bracket A	1
23	45-36-1655	Cylinder Spacer	1	64	40-50-3065	Adjustment Spring	1
24	34-40-3135	O-Ring	1	65	44-90-0710	Ring	1
25	34-40-3295	O-Ring	1	66	44-94-0560	Adjustment Rod Assembly	1
26	34-40-3300	O-Ring	1	67	43-98-0760	Adjustment Knob	1
27	42-52-0410	Plunger Cap	1	68	44-90-0790	Ring	1
28	44-70-0250	Valve Plunger	1	69	42-36-2015	Work Contact Bracket B	1
29	34-40-3285	O-Ring	1	70	42-38-0325	No-Mar Pad	1
30	34-40-3280	O-Ring	1	83	05-59-2025	Lock Nut	1
31	40-50-3195	Spring	1	93	31-94-0110	Trigger Valve Assembly	1
32	44-70-0255	Plunger	1				
33	34-40-3290	O-Ring	1				
34	43-64-0150	Trigger Valve Head	1				
35	06-65-1465	Spring Pin	1				

MILWAUKEE ELECTRIC TOOL CORPORATION
13135 W. Lisbon Road, Brookfield, WI 53005
Drwg. 3

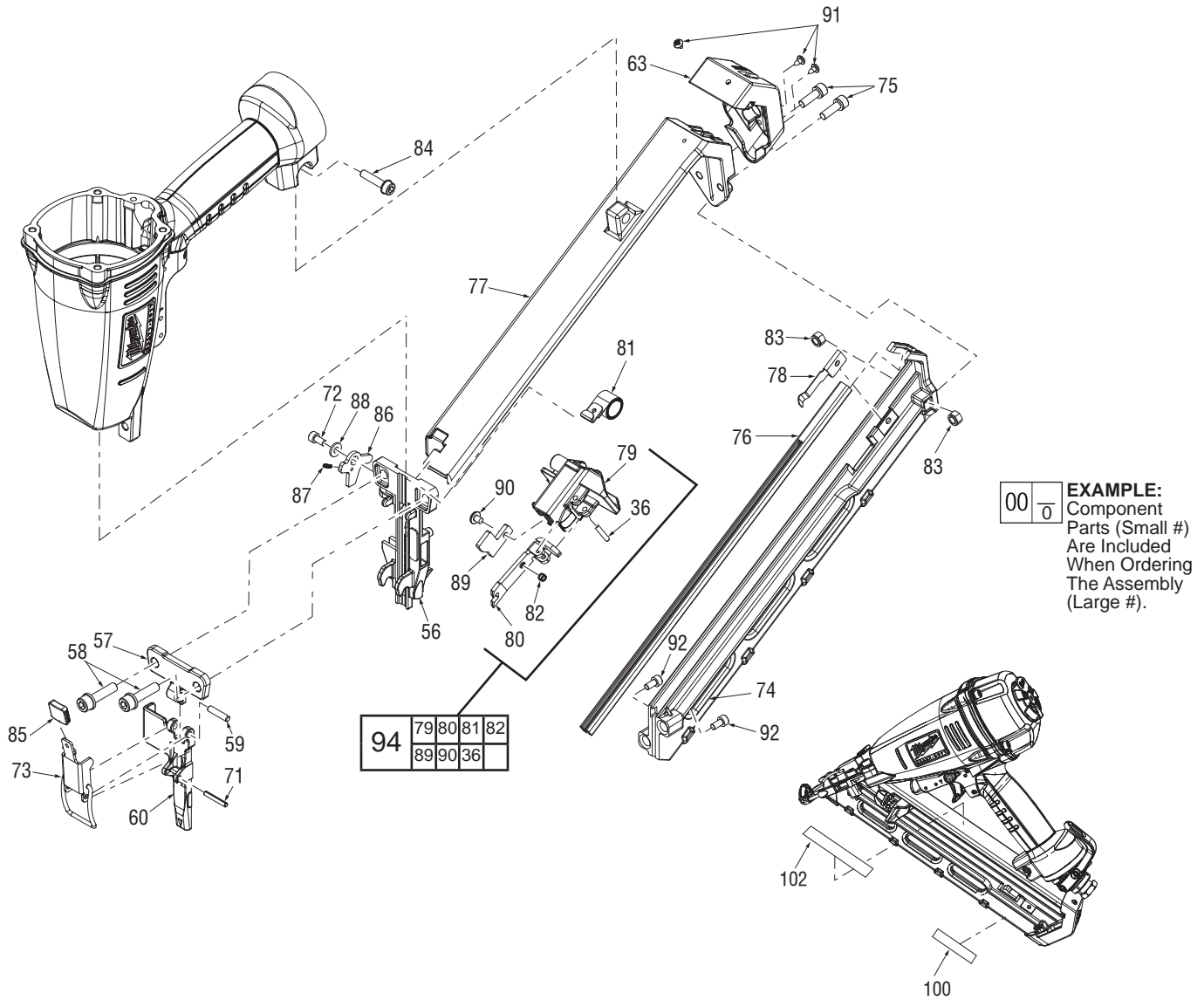

FIG.	PART NO.	DESCRIPTION OF PART	NO. REQ.	FIG.	PART NO.	DESCRIPTION OF PART	NO. REQ.
56	44-66-1300	Back Plate	1	82	40-50-3170	Pusher Spring	1
57	42-92-1400	Driver Guide Cover B	1	83	05-59-2025	Lock Nut	2
58	05-84-0860	Bolt Assembly	2	84	05-84-0910	Socket Hex Head Screw	1
59	44-60-1870	Fixed Pin	1	85	45-88-1705	Pusher Cushion	1
60	42-92-1385	Driver Guide Cover A	1	86	44-66-1340	Positional Plate	1
63	42-92-1455	Protecting Hood Cover	1	87	40-50-3025	Positioning Spring	1
71	06-65-1460	Spring Pin	1	88	45-88-1730	Flat Washer	1
72	05-84-0970	Socket Hex Head Screw	1	89	42-28-0365	Anchor Block	1
73	44-20-0850	Lock Handle Assembly	1	90	05-83-0540	Philips Screw	1
74	43-40-0475	Magazine A	1	91	05-78-0805	Tap Bolt	3
75	05-84-0900	Socket Hex Head Screw	2	92	05-84-0965	Socket Head Hex Bolt	2
76	44-81-0060	Steel Channel	1	94	45-24-0025	Magazine Pusher Assembly	1
77	43-40-0490	Magazine B	1	100	12-98-0315	Service Nameplate	1
78	44-66-1315	Nail Stop Plate	1	102	10-20-3310	Warning Label	1
79	42-92-1490	Protecting Hood Cover	1		14-70-0170	Overhaul Kit (Not Shown)	
80	43-72-0360	Pusher	1		14-70-0175	Driver Maintenance Kit (Not Shown)	
81	40-50-3000	Spring Assembly	1				

Disassembly:

- 1, 2, 3, 4, 6 Using a 4 mm hex key, remove hex bolt (1), deflector (3), muffler (4), and deflector pad (2) from top cap (6).
- 5, 6 Using a 4 mm hex key, remove hex bolts (5) to remove top cap (6).
- 8, 9, 10, 11, 12, 13 Remove valve assembly (8, 9, 10, 11, 12, and 13) out of the top cap using a 1/8 in. (3.18 mm) punch. Gently push punch through several different holes in the top of the cap to remove assembly evenly.
- 14, 19 Remove press ring (14) from the top of cylinder (19) before removing cylinder assembly.
- 15, 16, 17, 18, 19, 20, 21, 23, 24, 44 Remove driver assembly (15, 16, 17), and cylinder assembly (18, 19, 20, 21, 23, 24) from tool body (44) at the same time by placing two flat blade screwdrivers under top ring of cylinder (19), 180° apart, and gently prying the cylinder from the tool body.
- 18, 19, 20, 23 Remove cylinder ring (20) from cylinder (19) before removing cylinder spacer assembly (18, 23).
- 44, 56 74, 77 84 92 Remove magazine assembly (74 and 77) by removing screw (84) from tool body (44) and two screws (92) from magazine/driver guide (56).
- 36, 37, 38, 39, 40, 41, 42, 43, 44, 93 Remove trigger valve assembly (93) from tool body (44) by placing a 3/32 in. (2.5 mm) punch inside half moon slot of retainer (39) and gently tapping shaft of selector (38). Remove spring (42), retainer (39) and ring (43). Remove spring, (41) and trigger (40) from tool body and push pins (36), and 37) out of tool body (44) just far enough to remove valve assembly. Trigger valve assembly (93) can be gently pushed out of the tool body from the inside handle area of the tool body using a flat blade screwdriver.

Reassembly:

- 36, 37, 44, 93 Reinstall trigger valve assembly (93) into tool body (44) by aligning the grooves in the valve assembly with the two holes for spring pins (36 and 37). Drive spring pins into tool body until they are flush with the casting surface.
- 38, 39, 40, 41, 42, 43, 44 Reinstall selection lever assembly (38, 42, 39, 43,) and trigger assembly (40 and 41) by doing the following.
 - Place spring (42) onto shaft of selection lever (38).
 - Position spring (41) and trigger (40) over plunger of trigger valve assembly (93).
 - Insert selection lever assembly (38 and 42) into tool body (44) and align half-moon slot of retainer (39) with half-moon shaft of selection lever (38) and snap retainer assembly (39 and 43) onto the shaft.
- 17, 22, 44 Install flat side of driver guide (22) towards front of tool body (44).
Note: Center opening of driver guide (22) has a flat side and one with a slight offset to accommodate / help align blade of driver assembly (17) in the assembly
- 19, 20, 23, 24 Reinstall cylinder ring (20) onto cylinder (19) only after O-ring (24), and cylinder ring (23) have been installed.
Note: Large flanged end of cylinder ring (20) must facing the top of cylinder (19) when installed.
- 15, 16, 17, 18, 19, 20, 21, 22, 23, 44 Assemble driver assembly (15, 16, and 17) and install it into cylinder assembly (18, 19, 20, 21, and 23). Install assembled components into tool body (44).
Note: Orientation of driver assembly (17) must match orientation of driver guide (22).
- 6, 14, 19 Reinstall press ring (14) onto top of cylinder (19) with wide edge facing toward top cap (6).
- 6, 49 Reinstall bumper band (49) into slot on top cap (6).
- 6, 8, 9, 10, 11, 12, 13 Reinstall spring (8) into internal bore of top cap (6) and snap preassembled head valve assembly (9-13) into top cap.
- 5, 6, 44 Reinstall top cap assembly (6) onto tool body (44) using hex bolts (5).
Note: To properly seat top cap, tighten the screws at alternating corners a few turns at a time until all screws are secure.
- 44, 56, 74, 76, 77, 84, 92 Reinstall magazine assembly (74 and 77) onto tool body (44) by securing screw (84) and two screws (92) into magazine/driver guide (56).
Note: Before completely securing screws (93) make sure magazine channel (76) is aligned properly at the front and rear of the magazine assembly.
- 46, 54 Install smooth side of filter (54) toward end cap (46).
- Apply Blue Loctite® 242 to fasteners (1), (5), (47) (58), (72) and (92), if removed during disassembly.

Lubrication:

Type 'I' Grease 49-08-7100

Clean all parts with a dry clean cloth.

- | | |
|--|--|
| 6, 8, 9, 10, 11,
12, 13 | Place a thin coating of grease into internal bore of top cap (6), coat parts (8-13) and reassemble in order shown. |
| 15, 16, 17 | Coat o-ring (15) and piston ring (16) prior to installing into groove of driver assembly (17). |
| 18, 20, 23, 24 | Coat o-ring (24), cylinder spacer (23), o-ring (18) and cylinder ring (20) prior to installing onto cylinder (19). |
| 25, 26 27, 28, 29, 30,
31, 32, 33, 34, 35 | Coat all parts of the trigger valve assembly (25-35) if being replaced individually. Components cleaned in any type of solvent or water solution will require new lubrication.
Note: A new trigger valve assembly will be pre-lubricated and will not require any additional lubrication. |

Free Manuals Download Website

<http://myh66.com>

<http://usermanuals.us>

<http://www.somanuals.com>

<http://www.4manuals.cc>

<http://www.manual-lib.com>

<http://www.404manual.com>

<http://www.luxmanual.com>

<http://aubethermostatmanual.com>

Golf course search by state

<http://golfingnear.com>

Email search by domain

<http://emailbydomain.com>

Auto manuals search

<http://auto.somanuals.com>

TV manuals search

<http://tv.somanuals.com>