

MINOLTA

MAXXUM[®]
DYNAX[™]

3xi

E INSTRUCTION MANUAL

Download from www.Somanuals.com. All Manuals Search And Download.

READ ME FIRST!

First of all, thank you for purchasing this Maxxum/Dynax 3xi. Also, if this is your first Minolta camera, welcome to the Minolta family.

This instruction manual has been designed to help you get the most enjoyment and use out of your new camera. It is not necessary for you to read the contents of this manual from cover-to-cover before you begin photographing. Instead, it is better that you read it in sections.

Begin by learning a little about the manual itself by reading the **TABLE OF CONTENTS** on p.2. This will give you an idea of kinds of information included in the manual and the way in which it is organized. Next, pick up your camera and, using **NAMES OF PARTS AND DISPLAYS**, become familiarize yourself with the layout of its controls and indications. Continue to the next section, **PREPARATIONS**, and follow along with your own camera by attaching the neckstrap and a lens; inserting a battery, etc. When you are finished, read **SIMPLE OPERATION—THE BASICS** thoroughly and you should be ready to begin using your new camera in its most basic operating mode. When you want to take more creative control over the image-making process, **OPERATIONS IN DETAIL** will help you do so. Finally, **APPENDIX** contains information about the camera and general photography, as well as a **Quick Reference Guide**, which may be helpful to you in the near future. Refer to it as you need.

You are probably anxious to begin, so good luck and we hope that this camera will help you to discover and enjoy the many pleasures of the world of photography.

IMPORTANT INFORMATION

The Minolta Maxxum/Dynax 3xi was designed to work specifically with lenses, flash units, and other accessories manufactured and distributed by Minolta. We therefore caution users of this camera that the attachment and/or use of incompatible products with the 3xi may result in unsatisfactory performance or damage to the camera or its accessories. To obtain optimum performance throughout the life of your Maxxum/Dynax 3xi, we recommend that you use only those lenses, flashes and other accessories distributed by Minolta specifically for use with this camera.

TABLE OF CONTENTS

Names of Parts and Displays	Body	4
	Data Panel	6
	Viewfinder	7

PREPARATIONS

Preliminary	Neckstrap	9
	Eyepiece and Accessory Shoe Cap	9
Lens	Attaching	10
	Removing	11
	Care of glass surfaces	11
Battery	Inserting	12
	Battery-condition indicators	13
	Battery performance	14
	Cold-weather operation	14
Film	Automatic film-speed setting	15
	Loading film	15
	Automatic rewind	18
	Manual start of rewind	18

OPERATIONS IN DETAIL

Auto Stand-by Zoom (ASZ)	29
Focusing Details	AF illuminator	30
	Special focusing situations	31
	Manual focus	32
Exposure Details	Exposure modes	33
	Changing exposure modes	33
	A: Aperture priority	34
	S: Shutter priority	36
	M: Manual exposure	38
	Bulb: Long exposures	40
Flash Details	Manual fill-flash (P mode)	42
	Flash cancel (P mode)	42
	Flash in A, S, and M modes	43
	Flash range	43
	Wireless/remote off-camera flash control	44

SIMPLE OPERATION

Holding the Camera	20
Main Switch/Eye-Start	21
Taking Pictures	22
Focus Signals	23
Focus Lock	24
Flash Basics	25
Flash signals	25
Pre-flash	26
Self-Timer	27

APPENDIX

Lens Aperture and Depth of Field	49
Shutter Speed and Moving Subjects	51
Accessory Information	52
Troubleshooting	53
Care and Storage	54
Technical Details	56
Quick Reference Guide	59

NAMES OF PARTS AND DISPLAYS

Body

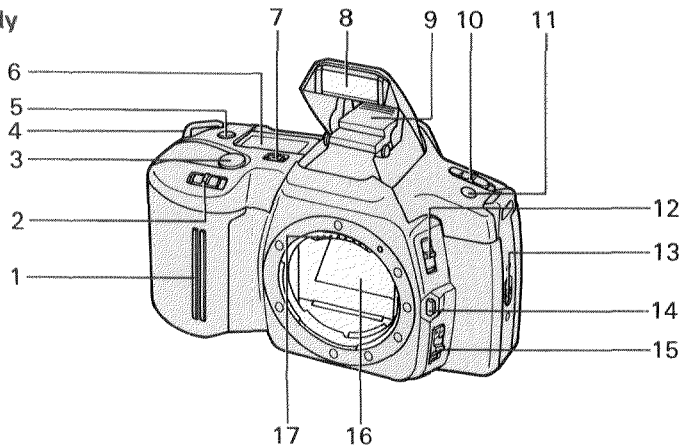

- | | |
|---|--|
| 1. Grip sensor
Activates eyepiece sensor | 8. Flash |
| 2. Shutter-setting control
Used to control shutter speed
in S and M modes and select
exposure mode | 9. Accessory shoe |
| 3. Shutter-release button | 10. Main switch |
| 4. Strap eyelet | 11. Self-timer button |
| 5. Pre-flash button
Selects/cancels pre-flash | 12. Aperture-setting control
Selects aperture in A and M
modes |
| 6. Data panel | 13. Back-cover release |
| 7. Program re-set button
Re-sets camera to
programmed operation | 14. Lens release |
| | 15. Focus-mode switch
Selects auto/manual focus |
| | 16. Mirror* |
| | 17. Lens contacts* |

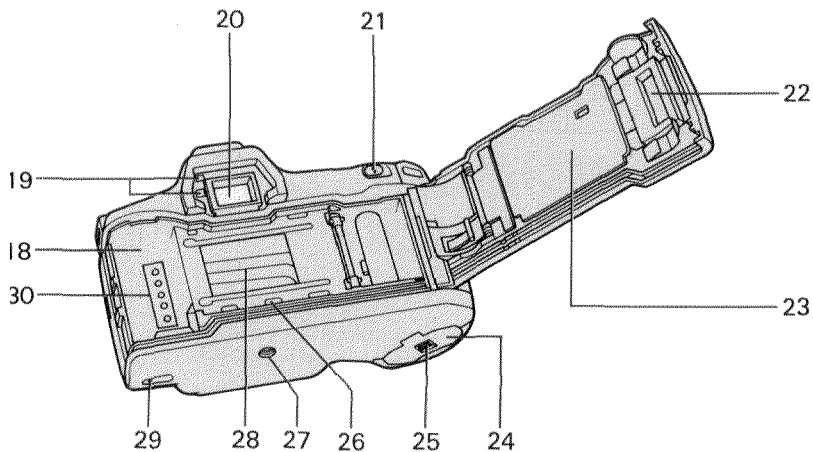

- | | |
|---|--|
| 8. Film chamber | 23. Pressure plate* |
| 9. Eyepiece sensor
IR sensor activates camera
when it detects an object
nearby | 24. Battery cover |
| 10. Viewfinder eyepiece* | 25. Battery-cover release |
| 11. Flash-control button
Used to pop-up built-in flash,
manually fire fill flash, and
cancel flash in P mode | 26. Guide rails |
| 12. Film window | 27. Tripod socket |
| | 28. Shutter* |
| | 29. Rewind button
Used to manually begin film
rewind |
| | 30. DX contacts* |

* Do not touch

(Names of parts and displays)

Data Panel

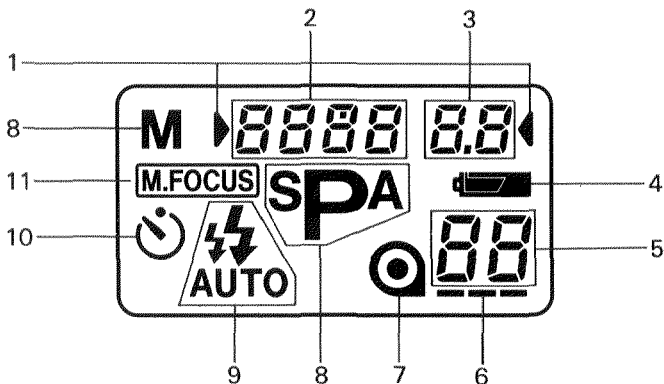

1. Selectable setting pointers
Indicates which settings are under manual control
2. Shutter-speed display
3. Aperture display
4. Battery-condition indicator
Displays level of battery charge
5. Frame counter
6. Film-transport signals
7. Film cartridge mark
Indicates film loaded, film rewind, film improperly loaded
8. Exposure-mode indicators
Indicates current exposure mode
9. Flash-mode indicators
Indicates current flash mode
10. Self-timer indicator
11. Manual-focus indicator

Viewfinder

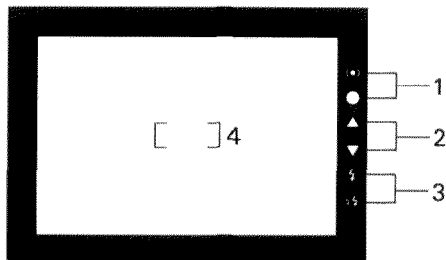

1. Focus signals

- Continuous AF mode: appears after Eye-Start when subject is in focus and after shutter-release button is pressed partway down if subject is moving
- Focus locked: appears a short time after shutter-release button is pressed part way down if subject is stationary

● (blinking) Focus cannot be confirmed

2. Exposure signals

In M mode:

▲ overexposure; ▼ underexposure; ◆ correct exposure

In P and A mode when flash is canceled:

▼ (blinking) Camera-shake warning: current shutter speed may result in blurry pictures

In all modes:

◆ (blinking) Correct exposure not possible

▼ (blinking) Flash charging

3. Flash signals

⚡ (blinking slowly) Flash charged

⚡ (blinking rapidly) Flash output sufficient

4. Focus frame

PREPARATIONS

This section includes those things which you should do and understand before you use your camera. Read it thoroughly before you go on to **SIMPLE OPERATION** or **OPERATIONS IN DETAIL**.

PRELIMINARY

Neckstrap

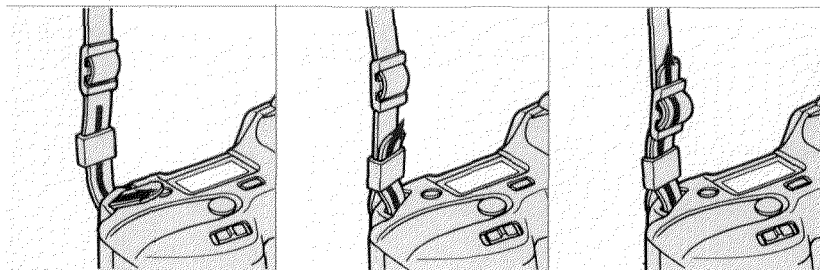

A neckstrap is supplied with your camera. Attach it as shown above.

Eyepiece and Accessory Shoe Cap

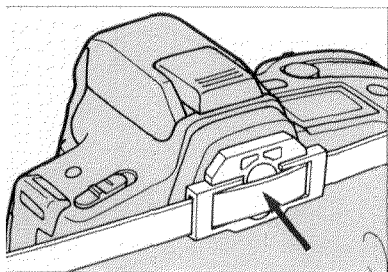

An eyepiece cap is attached to the strap. Fasten it to the viewfinder eyepiece whenever you use the self-timer or make long exposures. To attach the cap, snap it in place over the eyepiece as shown above; pull to remove.

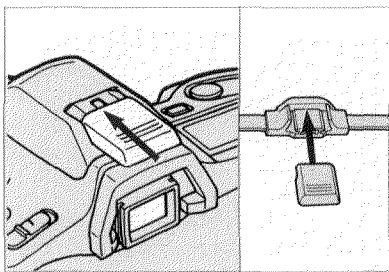

The camera also comes with an accessory shoe cap which protects the accessory-shoe contact. When you are using a flash or other accessory, slide the accessory shoe cap into the eyepiece cap for safekeeping.

LENS

Attaching

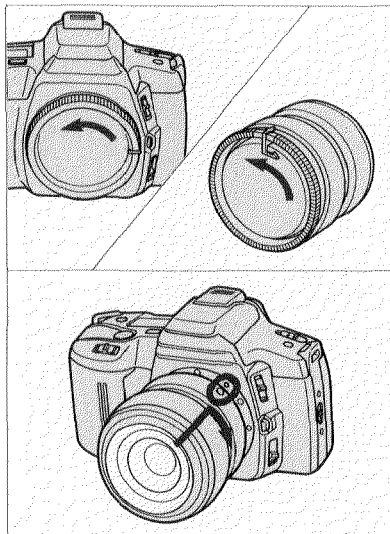

1. Turn the body cap and lens cap as shown and remove them.

2. Align the red bead on the lens barrel with the red dot on the camera's lens mount. Fit the lens into the mount and turn the lens clockwise until it locks in place with a click.

Be careful...

- Do not force the lens if it does not turn smoothly.
- Never touch anything inside the camera, especially the lens contacts and mirror.

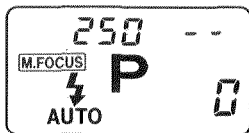

"--" will appear in the aperture display of the data panel if:

- No lens is attached to the camera
- The lens is not attached properly
- The AZ/MZ switch on an xi-Series lens is set to MZ

Removing

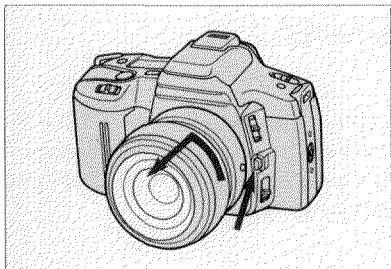

1. Press the lens release and hold it in while you turn the lens counter-clockwise until it stops. Lift the lens out of the mount.

2. Immediately attach the rear cap to the lens and the body cap or another lens to the camera. This will protect the lens elements, lens contacts, and camera interior.

Care of Glass Surfaces

- Never touch any lens surfaces (including the eyepiece) with your fingers. If a lens becomes dirty, first gently clean it with a lens brush. Then, if necessary, moisten a sheet of lens tissue with one drop of lens-cleaning fluid and, starting from the center of the lens, wipe the glass using a circular motion.
- Never lift the mirror or touch its surface. This may impair its alignment or scratch its face. Dust on the mirror's surface will not affect meter readings or picture quality. If it is distracting, have the camera cleaned at an authorized Minolta service facility.

BATTERY

This camera uses a 6-volt 2CR5 lithium battery to supply power to all of its operations. If you are also using an xi-Series lens, the camera battery also supplies power to the zoom motor built into the lens.

Inserting

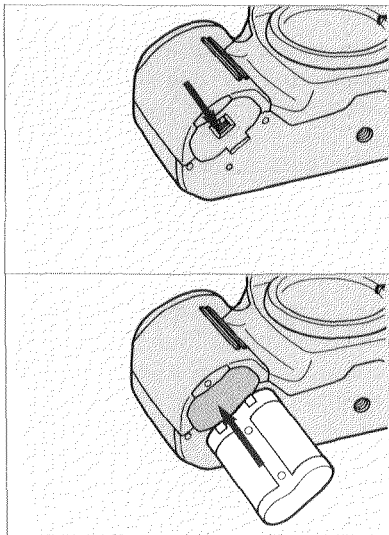

1. Move the main switch to **LOCK** and slide the battery cover release in the direction indicated to open the battery cover.

2. Insert the battery according to the marks on the inside of the chamber cover.

3. Snap the cover closed.

CAUTION

- Read and follow all warnings and instructions supplied by the battery manufacturer.
- Do not attempt to disassemble, recharge, or short-circuit the battery. Do not subject it to high temperatures or fire. The battery may explode and cause severe burns.
- Keep batteries away from small children.

Battery-condition Indicators

Whenever you move the main switch from **LOCK** to **ON**, one of the following indicators will appear in the data panel.

Indicator

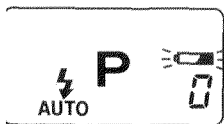
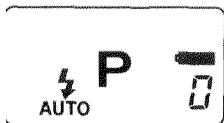

Meaning

1. Full-battery symbol appears for 4 sec. after you turn camera on—power is sufficient.

2. Low-battery symbol appears for 4 sec. after you turn camera on—power is sufficient, but getting low. **Keep a fresh battery handy.**

3. Low-battery symbol blinks while it appears with other operating indicators at any time during use—camera can be operated, but power is extremely low. **The battery will need to be changed soon.**

4. Blinking low-battery symbol and **bAtt** appears, or no display appears at all, and shutter locks—power is insufficient for operation. **Replace the battery or check that the battery is inserted correctly.**

► Indicator 4 will appear even while the main switch is set to **LOCK**.

(Battery)

Battery Performance

The 6-volt 2CR5 lithium battery should provide sufficient power for shooting up to 60 rolls of 24-exposure film without flash. These figures are based on Minolta's standard test method using a fresh battery at 68°F (20°C). Actual performance will depend on how you use the camera. If you install a new battery that has been in prolonged storage, the camera's performance may vary.

Cold-Weather Operation

Lithium batteries perform well in cold weather. However, if you plan to shoot many rolls of film outdoors at temperatures near or below 32°F (0°C), we recommend that you carry the camera inside your coat to keep it warm while you are not shooting. You may also want to carry a spare battery in your pocket so that you can change the camera battery if necessary. Do not discard a cold battery. After it warms up, it will regain some of its charge.

FILM

Automatic Film Speed Setting

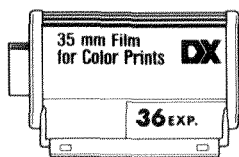

If you use DX-coded film between ISO 25 and 5000, the camera will automatically set the correct film speed. For flash photography, Minolta recommends that you use film between ISO 25 and 1000. If you use non-DX-coded film, the camera will automatically set ISO 100.

Loading Film

Before you load a roll of film, always check the data panel. If the film cartridge is displayed, **do not open the back cover**. Check the film window and frame counter to verify the type of film in the camera and the number of frames remaining. (See p.18 for instructions on rewinding an unfinished roll of film.)

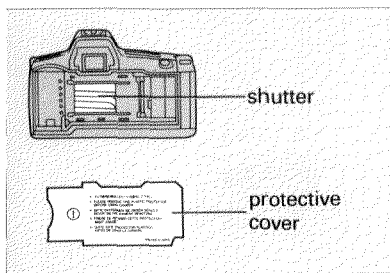

- Always load film in subdued light or shade.
- Before you load film for the first time, carefully remove and discard the protective plastic cover over the shutter.

— NEXT PAGE —

(Film)

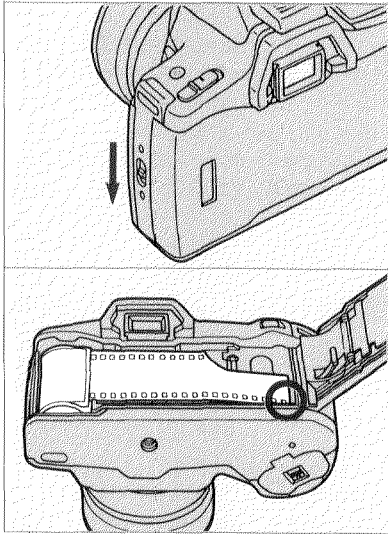

1. Open the back cover by sliding the back-cover release downward.

2. Place the film cartridge into the film chamber and extend the leader between the guide rails until the tip is just past the film-leader index.

RIGHT

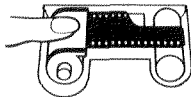

WRONG

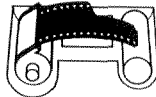

● **NEVER TOUCH THE SHUTTER CURTAIN WITH YOUR FINGERS OR WITH THE FILM TIP.** Its precision design makes it extremely sensitive to pressure.

- If the film leader is torn or crimped, it may not wind properly.
- If the film tip extends beyond the mark, gently push the excess back into the cartridge.

— NEXT PAGE —

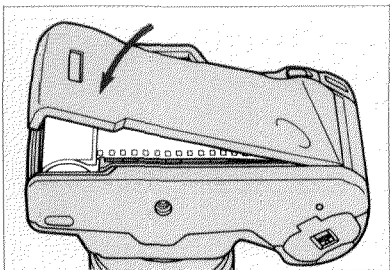

3. Close the back cover and move the main switch to **ON**. The camera will automatically advance the film to the first frame and **1** will appear in the film counter.

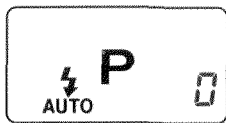

• If the film is loaded incorrectly, **0** will blink in the frame counter and the shutter will remain locked. Open the back cover and repeat steps 2 and 3.

- If you move the main switch to **ON** before you load film, do not touch the grip sensor during the above procedures because ASZ may activate.
- If you accidentally open the back cover before you rewind the film, quickly shut the back. The counter will reset to **1**. Some of the pictures you have already taken will be ruined or will be discolored along the edges.

Automatic Rewind

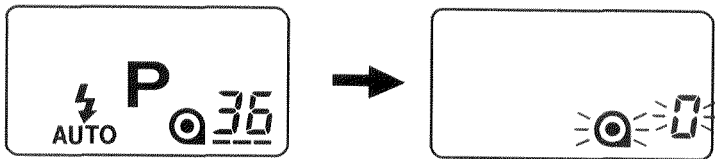

After you have exposed the last frame, the camera will automatically rewind the film. With a fresh battery, it takes about 18 sec. to rewind a 36-exposure roll, or 12 sec. for a 24-exposure roll.

When the film has been completely rewound, the motor will stop and the film-cartridge mark in the data panel will blink to indicate that it is safe to open the back cover.

Manual Start of Rewind

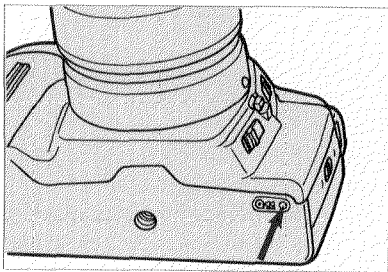

To begin rewind at any time, gently press the film rewind button on the bottom of the camera body.

- If the motor stops before the film is completely rewound, insert a fresh battery.

SIMPLE OPERATION — THE BASICS

This brief section is intended to help you get started using your new camera. It explains the simplest method of operation—with programmed autoexposure, autofocus, and autoflash. Details on each of the camera's functions begins on p.28 in the section entitled "Operation in Detail".

HOLDING THE CAMERA

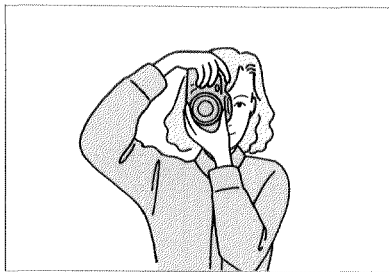
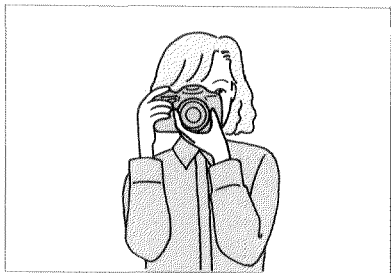

Hold the grip firmly in your right hand and use your left hand to support the camera or lens. Keep your elbows securely against your sides when shooting both horizontal and vertical pictures. Press the shutter-release button gently in a single, steady motion—never with a quick jab. Always keep the camera strap around your neck or wound around one wrist.

- When you pick up the camera, make sure you touch the grip sensor. Otherwise, Eye-Start will not function.
- Do not touch the focusing ring of an AF lens or the end of the lens barrel of an xi-Series Autozoom lens or AF Power Zoom lens.

MAIN SWITCH/EYESTART

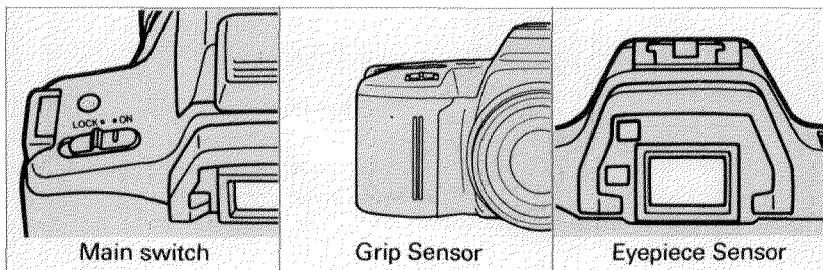

Main switch

Grip Sensor

Eyepiece Sensor

When you move the main switch to ON, the data panel and grip sensor activate. When you then touch the grip sensor, the eyepiece sensor is activated. This sensor then immediately activates autofocus and autoexposure when it detects an object near the viewfinder. If you are using an xi-Series Autozoom lens, auto stand-by zoom (ASZ) is also activated by Eye-Start and the lens will zoom automatically. By the time you frame your subject, therefore, the camera has performed many of its set-up operations and is ready to make an exposure. The eyepiece sensor also turns autofocus and autoexposure off 4 sec. after it no longer detects an object near the viewfinder.

- If you do not touch the grip sensor or if you are wearing gloves, you must activate autofocus and autoexposure by pressing the shutter-release button partway down. ASZ will not function in this case.
- If you are wearing sunglasses which absorb infrared light, Eye-Start may not function.

TAKING PICTURES

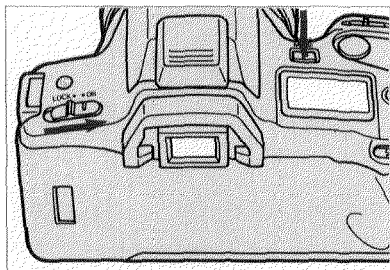

1. Slide the main switch to **ON**.
2. Press the program-reset button.
 - Pressing the program-reset button sets the camera to programmed autoexposure mode, autofocus, and auto switchover flash.
3. Hold the camera as described on p. 20.
4. Place your main subject in the focus frame and press the shutter-release button down to take the picture.

After the exposure has been made, the camera will automatically advance the film to the next frame and will increase the film counter by one.

FOCUS SIGNALS

Signal	Meaning (notes below)
(●)	Continuous autofocus ¹
●	Focus is locked ¹
⇒ ● ⇐ (blinking)	Focus cannot be confirmed ²

1. After Eye-Start has activated the camera, the autofocus system will enter continuous AF mode and (●) will appear in the viewfinder when it has focused on your subject. When you press the shutter-release button partway down, if your subject is stationary the camera will lock focus a short time later and ● will appear in the viewfinder. If your subject is moving, the camera will remain in continuous AF mode.

2. See p.31.

● This camera has Predictive AF. When you take a picture in continuous mode, the camera will calculate where the main subject will be when the shutter curtain actually begins to make the exposure, and it will set the lens to focus on this point before the mirror swings up. Extremely fast-moving subjects or subjects which are rapidly changing speed or direction, however, may exceed the capabilities of this system.

FOCUS LOCK



If, as a result of the composition or framing you have chosen, the main subject falls outside the main focus frame, first lock focus on your subject, then recompose the scene as desired.



1. Place your subject in the center of the AF area.

2. Press the shutter-release button partway down.

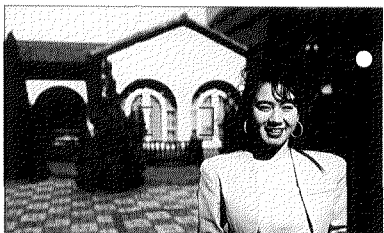

3. Wait for the focus signal to change from (●) to ●, recompose the picture, and press the shutter-release button all the way down to take the picture.

● Focus will not lock if your subject is moving.

Focus lock with the lens control ring:

If you are using an xi-Series or power zoom lens, you can lock focus by pulling the lens control ring towards the camera. Hold it in this position while you recompose and take the picture. Do not turn the ring after you lock focus.

FLASH BASICS

With programmed autoexposure (P mode), the camera begins measuring the brightness of your subject and the surrounding scene as soon as Eye-Start activates the camera. In P mode, the built-in flash will automatically pop-up when you press the shutter-release button partway down and fire whenever necessary.

- If you are using a lens hood, remove it before you take a photograph with the built-in flash.

Flash Signals

Viewfinder Signal	Meaning
▼ blinking	Flash charging
⚡ blinking slowly	Flash charged (pre-flash not selected)
⚡ blinking slowly	Flash charged (pre-flash selected)
⚡ blinking rapidly	Flash output sufficient (pre-flash not selected)*
⚡ blinking rapidly	Flash output sufficient (pre-flash selected)*

* This signal appears after you take the picture when the light supplied by the flash was enough to provide a correct exposure.

(Flash Basics)

Pre-Flash

In photos of people, sometimes the subject's eyes appear to glow bright red. This is caused by light from the flash reflecting off the interior of the person's eyes. This camera has a pre-flash feature which reduces the appearance of "red eye". In pre-flash mode when you press the shutter-release button completely down, the flash will fire a series of pulses before the main burst. This causes your subject's pupils to close slightly and greatly reduces the amount of light which will reflect off of the inside of their eyes.

To select pre-flash:

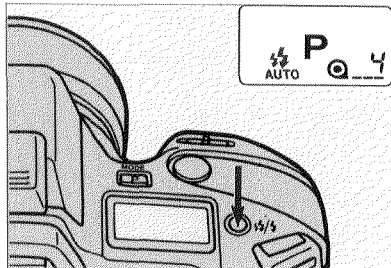

Press the pre-flash button once so that  appears in the data panel. The pre-flash will fire before every flash exposure.

To cancel pre-flash:

Press the pre-flash button again;  will appear in the data panel.

- Pressing the program re-set button will not cancel pre-flash.
- When you use pre-flash, warn your subject before you take the picture that the flash will fire several times so that they know what to expect.
- The built-in flash also acts as the camera's AF illuminator. Canceling pre-flash **will not** cancel the AF illuminator flash. See p.30 for details.

SELF-TIMER

The electronic self-timer will delay release of the shutter by about 10 sec. from the time you press the shutter-release button.

To activate the self-timer:

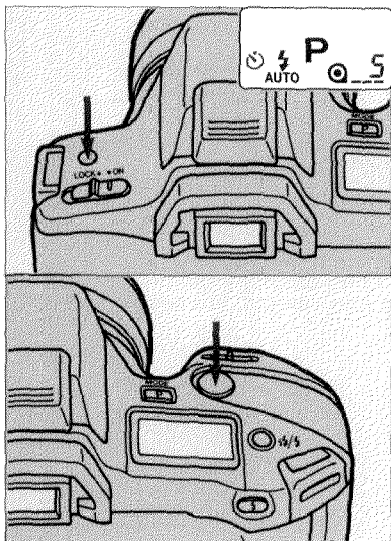

1. Press the self-timer button. The self-timer indicator will appear in the data panel.

● Press the self-timer button again to cancel.

2. Compose your scene and attach the eyepiece cap.

3. Press the shutter-release button.

● In P mode, unless you have cancelled the flash, three small bursts will fire just before the shutter releases. In A, S, and M modes, this will happen only if you first pop-up the flash. To cancel this self-timer announcement without cancelling normal flash operation, press and hold the pre-flash button down and move the main switch from **LOCK** to **ON**.

● If a dedicated accessory flash is attached, its AF illuminator will blink three times just before the shutter releases.

● To cancel the self-timer while it is operating, move the main switch to **LOCK**.

● The self-timer automatically switches off after shutter-release. To make another exposure with the self-timer, repeat steps 1-3.

OPERATIONS IN DETAIL

Once you have learned the basics of using your camera, this section will help you to take more control over its operation.

AUTO STAND-BY ZOOM (ASZ)

If you are using an xi-Series Autozoom lens, the camera's automatic control also extends to zooming the lens. Whenever Eye-Start activates the camera, the lens immediately sets a programmed focal length based on the distance to your subject. This setting should provide a good starting-point in your composition.

- ASZ's operation is a one-shot function; it will not set a new focal length every time you point the camera at a new subject unless you first take the camera away from your eye. If you use power zoom to change ASZ's setting, ASZ will not function again until you remove the camera from your eye and wait 20 sec.
- If the grip sensor does not activate Eye-Start, ASZ will not function. In this case, pressing the shutter-release button partway down will activate all of the camera's automatic systems except ASZ.

To cancel ASZ:

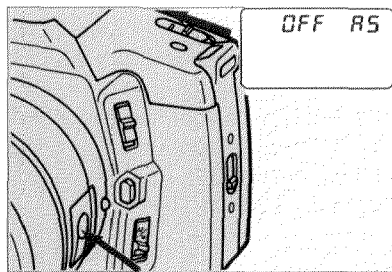

Press and hold the lens-function button on the lens barrel while you move the main switch from **LOCK** to **ON**. **OFF AS** will appear in the data panel.

- To turn ASZ on again, repeat the above step. **ON AS** will appear in the data panel.
- ASZ does not work if you are using an AF Power Zoom lens.
- No other autozoom functions are available when this camera is used with an xi-Series Autozoom lens.

FOCUSING DETAILS

AF Illuminator

When flash is required, if the AF system cannot detect a subject to focus, the built-in flash will automatically fire low-power bursts when you press the shutter-release button partway down. This provides focus-assist lighting for the AF system to operate normally even in complete darkness.

To cancel AF illuminator:

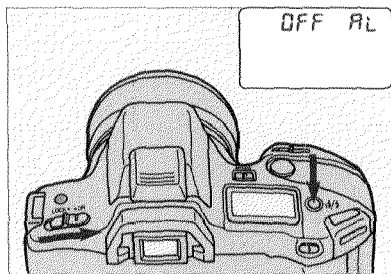

Press and hold the pre-flash button down while you move the main switch from **LOCK** to **ON**. **OFF AL** will appear in the data panel.

- To re-activate the AF illuminator, repeat the above procedure. **ON AL** will appear in the data panel.
- The AF illuminator will not work in P mode if the flash is not necessary or if you have canceled it, or in A, S, or M mode if the flash is down.
- Canceling pre-flash will not effect the AF illuminator.
- The range of the AF illuminator is approximately 3.3-16ft. (1-5m).

Free Manuals Download Website

<http://myh66.com>

<http://usermanuals.us>

<http://www.somanuals.com>

<http://www.4manuals.cc>

<http://www.manual-lib.com>

<http://www.404manual.com>

<http://www.luxmanual.com>

<http://aubethermostatmanual.com>

Golf course search by state

<http://golfingnear.com>

Email search by domain

<http://emailbydomain.com>

Auto manuals search

<http://auto.somanuals.com>

TV manuals search

<http://tv.somanuals.com>