

Service Manual

XG-1(n) (CODE No. 2007-300)

XG-A (CODE No. 2013-300)

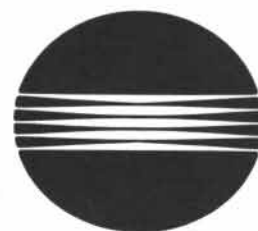

MINOLTA

MINOLTA XG1(n)

2007-300 (For Export)

TYPE OF CAMERA

35 mm single-lens reflex with automatic and full manual exposure control

SHUTTER

Horizontal-traverse focal-plane type; electronically controlled speeds.

Shutter speed : Auto-1/1000 to 1 sec. (stepless)
Manual-1/1000, 1/500, 1/250, 1/125,
1/60, 1/30, 1/15, 1/8, 1/4,
1/2, 1 sec. and B (Bulb)

Shutter dial : Up to ± 2 Ev continuous adjustment of automatic exposure with 1/2 Ev click-stops and lock at "A" (zero setting)

Self-timer : Electronic, LED indicated types, approximately 10 sec. delay

Flash sync : PC terminal and hot shoe for X-sync. (disconnect when unit not installed).
Electronic flash synchronizes at 1/60 sec. and slower step or stepless speeds; Class MF, M, FP flashbulbs synchronize at 1/15 sec. or slower speeds.
Extra contact on hot shoe receives signal from camera-control contact of the X-series Auto Electroflashes

FILM ADVANCE

Film winding : By lever with single 130° stroke after 30° unengaged movement Film-advance release button for rewinding; advancing-type frame counter and Safe Load Signal that indicates film loading and advancing conditions

Auto winding : Through built-in coupler key with accessory Auto Winder G

Spool : 4-slot take-up spool

Film counter : Auto resetting calculation

VIEWFINDER

Type : Eye-level fixed pentaprism type

Viewfinder vision : 93% (standard 24 mm \times 36 mm imagefield)

Magnification : 0.87 \times (50 mm standard lens at ∞)

Visibility : -1 diopt

Viewfinder indication : Accute Matte-field focusing screen with central horizontally oriented split-image focusing spot surrounded by microprism band; stepless speeds indicated by 7 light-emitting diodes; LED over-/under-range indicators, LED at "60" position also blinks as flash-ready signal with the X-series Auto Electroflashes, manual-mode signal

Mirror : Oversize quick-return type

EXPOSURE CONTROL

Light-Metering system : Full-aperture TTL center-weighted averaging type



Receiver element : By two CdS cells mounted on either side of the eyepiece at the rear of the pentaprism

Auto-exposure control : Special low-voltage, low-current computer circuit, actuated by contact or pressure on "touch switch" operating button, varies the shutter speed continuously and steplessly to yield proper exposure according to metering system indication at the aperture, film speed, and exposure adjustment set.

Auto-exposure range : Ev 2 to Ev 17 (e.g., 1/2 sec. at f/1.4 to 1/1000 sec. at f/11) at ASA 100 with f/1.4 lens

Film-speed range : ASA 25 to 1600 set on the shutter-speed/function selector

Power : Two 1.5V alkaline-manganese (Eveready A-76 or equivalent) or 1.55V silver-oxide (Eveready EPX-76/S-76 or equivalent) cells power both auto exposure control and shutter's electronically governed operation
LED battery check indicator lights when operating switch in battery check position
Shutter will not release when voltage too low for proper operation

OTHER

Back cover with memo holder and ASA-DIN conversion table; integral grip

ACCESSORIES

- Exclusive Auto Winder G
- Auto Electroflash 320X, 200X, 132X and 118X
- Remote Cord S 50 cm (20-in.) and Remote Cord L 5 m (16-ft.)
- Wireless Controller IR-1
- MD, MC, and other interchangeable Minolta lenses and applicable Minolta SLR system accessories

SIZE AND WEIGHT

Size : 52 (D) \times 89 (H) \times 138 (W) mm
(2-1/16 \times 3-1/2 \times 5-7/16 in.)

Weight : 500 g (17-5/8 oz.)
without lens and power cells

I N D E X

Part No.	Page	Part No.	Page	Part No.	Page
※ 2007-1005-----	6	2005-1061-----	6	2019-1361-----	1
2006-1006-----	9	2006-1061-----	2		
2019-1007-----	1	2005-1062-----	6	※ 2007-2002-----	1
2006-1008-----	9	2006-1062-----	2	2006-2005-----	1
2006-1009-----	1	2005-1063-----	6	2006-2008-----	16
2005-1010-----	6	2006-1064-----	6	2006-2009-----	16
2006-1011-----	6	2013-1068-----	2	2006-2012-----	16
2006-1012-----	13, 15	2006-1069-----	2	2006-2014-----	1
2006-1014-----	9	※ 2007-1074-----	6	2006-2015-----	16
2019-1015-----	3			2006-2016-----	16
2007-1016-----	3	2007-1105-----	15	2006-2017-----	16
2019-1018-----	2	2007-1106-----	4	2019-2018-----	1
2006-1019-----	3	2006-1110-----	15	2019-2020-----	1
2006-1020-----	13, 15	2019-1111-----	15	2006-2022-----	1
0031-1027-----	13, 15	2006-1112-----	15	2019-2023-----	1
0031-1034-----	13, 15	2019-1114-----	4	2006-2035-----	8
2006-1041-----	15	2019-1115-----	4	※ 2007-2070-----	1
2006-1042-----	15	2006-1116-----	4		
2006-1043-----	15	2006-1117-----	4	2006-2104-----	18
2019-1052-----	2	2006-1119-----	4	2006-2105-----	18
		2019-1351-----	2	2006-2106-----	18
2006-1054-----	2	※ 2007-1360-----	1	2006-2114-----	17

I N D E X

Part No.	Page	Part No.	Page	Part No.	Page
2006-0120-----	6	※2007-0272-----	16	2006-0415-----	1
2019-0132-----	2	2006-0273-----	16	2006-0416-----	1
2006-0140-----	4	2006-0274-----	16	2006-0420-----	5
2006-0151-----	9	※2007-0277-----	16	※2007-0440-----	1
2006-0152-----	9	※2007-0281-----	1		
2006-0153-----	9	※2007-0290-----	1	2006-0503-----	11
※2007-0170-----	2			2009-0505-----	7
※2007-0191-----	4	2019-0310-----	14	2009-0510-----	7
		2006-0325-----	13	2006-0521-----	11
2006-0207-----	18	2019-0326-----	14	2006-0522-----	10
2006-0209-----	18	2006-0338-----	13	2006-0523-----	10
2006-0211-----	18	2019-0340-----	14	2019-0524-----	10
2006-0215-----	17	2006-0350-----	14	2006-0527-----	9
2006-0218-----	17	2019-0360-----	14	2009-0531-----	10
2006-0222-----	17	2019-0375-----	1	2009-0532-----	10
2006-0229-----	17	2019-0381-----	12	2009-0542-----	10
2006-0242-----	17	2019-0384-----	12	2006-0558-----	11
2006-0253-----	18	2006-0385-----	12	2006-0561-----	11
2006-0258-----	18	2019-0396-----	1	2006-0562-----	11
2006-0259-----	18			※2007-0566-----	7
2006-0267-----	18	※2007-0402-----	19	2006-0586-----	6
2006-0271-----	16	※2007-0413-----	1	2019-0580-----	8
				2013-0596-----	3

※:Parts for only 2007-300(XG-1n)

※印は2007-300 (XG-1n) 専用部品

I N D E X

Part No.	Page	Part No.	Page	Part No.	Page
2006-2130-----	17	2006-2726-----	17	2006-3029-----	14
2006-2131-----	17	2006-2749-----	18	2006-3032-----	13
2006-2132-----	17	2006-2757-----	18	2006-3037-----	13
2006-2143-----	17	2006-2758-----	18	2006-3040-----	14
2006-2144-----	17	2006-2762-----	18	2006-3041-----	13
2006-2147-----	17	2006-2766-----	18	2006-3042-----	13
2006-2148-----	17	2006-2768-----	18	2006-3051-----	14
2006-2183-----	18	2006-2773-----	18	2006-3052-----	13
2006-2184-----	18	2006-2791-----	18	2006-3053-----	13
2006-2185-----	18			2006-3055-----	13
2006-2189-----	18	2019-3002-----	1	2006-3056-----	14
2006-2192-----	18	2006-3003-----	1	2006-3057-----	14
2006-2196-----	18	2019-3004-----	1		
2006-2197-----	18	2006-3009-----	14	2019-3301-----	1
		2006-3010-----	5	2019-3303-----	1
2006-2214-----	18	2006-3012-----	14	2019-3304-----	15
2006-2291-----	9	2019-3013-----	1	2019-3306-----	1
		2006-3020-----	14	2019-3308-----	15
2006-2707-----	17	2006-3021-----	14	2019-3309-----	15
2006-2708-----	17	2019-3024-----	5	✱ 2007-3310-----	1
2006-2718-----	17	2006-3027-----	14	2019-3311-----	1
2006-2723-----	17	2006-3028-----	14	2006-3312-----	15

I N D E X

Part No.	Page	Part No.	Page	Part No.	Page
2006-3404-----	12	2019-4256-----	2	2007-5026-----	3
2019-3407-----	12	2006-4260-----	3	2006-5027-----	11
2006-3408-----	12	2005-4270-----	16	2006-5028-----	11
2006-3410-----	12			2006-5029-----	11
2006-3411-----	12	2006-4301-----	19	2006-5030-----	11
2006-3412-----	12	2006-4302-----	19	2006-5031-----	7
2006-3414-----	12	2006-4303-----	19	2006-5032-----	7
2006-3415-----	13	2006-4304-----	19	2009-5035-----	7
2019-3416-----	13			2006-5038-----	9
2006-3421-----	13	2006-5006-----	3	2006-5039-----	7
		2006-5008-----	3	2006-5042-----	10
2006-4016-----	1	2006-5011-----	7	2006-5044-----	10
※2007-4017-----	2	2006-5013-----	7	2006-5046-----	10
2019-4019-----	1	2006-5014-----	7	2009-5051-----	10
2019-4022-----	1	2006-5015-----	7	2009-5058-----	10
※2007-4025-----	1	2006-5016-----	7	2009-5081-----	11
		2019-5017-----	7		
2006-4216-----	5	2006-5018-----	7	2006-5110-----	11
2006-4253-----	16	2006-5019-----	11	2006-5111-----	11
2006-4254-----	3	2006-5021-----	11	2006-5112-----	11
2006-4255-----	9	2006-5023-----	11	2006-5113-----	11
		2006-5024-----	7	2006-5114-----	11

5

I N D E X

Part No.	Page	Part No.	Page	Part No.	Page
2006-5116-----	11			2013-9246-----	2
2006-5117-----	11				
2006-5118-----	11	2006-9004-----	8	2006-9401-----	15
2006-5119-----	11	2006-9005-----	9	2006-9409-----	15
2006-5120-----	11	2006-9011-----	14		
		2006-9012-----	14	Screw	
2007-5801-----	3	2006-9103-----	9	9611-1616-07-----	11
2007-5803-----	7	2006-9105-----	16	9611-1620-01-----	18
2009-5805-----	7	2006-9106-----	11, 13	9611-1625-07-----	8, 9
2019-5806-----	11	2006-9107-----	9	9611-1630-01-----	15
		2019-9108-----	14	9611-2032-04-----	6
2006-8401-----	20	2006-9110-----	1, 5	9611-2090-07-----	13, 15
2006-8402-----	20	2006-9111-----	1	9612-1616-02-----	9
2006-8403-----	19, 20	2006-9112-----	2	9612-1616-07-----	6, 11
2006-8404-----	20	2006-9113-----	5	9612-1618-01-----	18
2006-8406-----	20	2006-9121-----	15	9612-1620-01-----	17, 18
2006-8408-----	19, 20			9612-1625-07-----	8
2006-8409-----	20	2006-9131-----	3, 5	9612-1628-07-----	6, 8
2006-8411-----	19, 20	2006-9132-----	5	9612-1635-07-----	6
2006-8413-----	20	2006-9133-----	5	9612-1675-07-----	16
2006-8417-----	20			9612-1685-07-----	3
		2006-9245-----	2		

6

I N D E X

Part No.	Page	Part No.	Page	Part No.	Page
9613-1418-07-----12		9763-1755-07-----1		Diode	
9613-1645-07-----8				9361-5631-01-----19	
9613-1650-01-----2		E-ring		Transistor	
		9721-0080-13-----11			
9615-1416-01-----17		9721-0120-13---12,18		9363-1032-01-----19	
9615-1420-01-----17		9721-0150-13--- ^{10,11} 17,18			
9615-1625-02-----17		9721-0200-13-----13		Fixed resistor	
9622-1630-01-----7					
		Steel ball		9422-1026-32-----3	
9693-1740-04-----1		9758-0200-00-----1		9422-1036-62-----19	
9695-1740-07-----3,7				9422-1046-32-----19	
		Washer		9422-1046-39-----19	
9761-1728-07-----4		9792-2050-40-----10		9422-1226-32-----3	
9761-1745-07-----1		9793-1635-40-----17		9422-1516-32-----3	
9761-2040-07-----13		9793-1840-86-----3		9422-1526-32-----3	
9761-2050-07-----15		9793-2038-50-----14		9422-1826-32---3,19	
9761-2055-07-----12		9793-2140-40-----10			
		9794-3858-20-----11		9422-2036-39-----19	
9762-1740-07---5,7,15		9798-3155-87-----2		9422-2046-39-----19	
9762-1745-07-----3,12		9793-2250-40		9422-2216-32-----3	
9762-2040-07-----14		L.E.D		9422-2236-39-----19	
9762-2050-07-----14		9353-2642-01-----18		9422-2416-62-----19	

7

I N D E X

Part No.	Page	Part No.	Page	Part No.	Page
9422-2436-39-----	19	9431-1037-31-----	19	9534-1555-33-----	19
9422-2716-32-----	3	9431-1057-31-----	3	9534-1555-63-----	19
9422-2736-39-----	19	9431-1257-31-----	3	9535-1555-31-----	19
		9431-1557-31-----	3	9535-1555-36-----	19
9422-3016-62-----	19	9431-3047-31-----	19	9535-6845-31-----	19
9422-3036-39-----	19	9431-3347-31-----	3	9563-4738-31-----	19
9422-3036-62-----	19	9431-3947-31-----	3		
9422-3316-32-----	3	9431-4747-31-----	3		
9422-3326-32-----	19	9431-5647-31-----	3		
9422-3336-39-----	19	9431-6847-31-----	3		
9422-3916-32-----	3, 19	9431-8247-31-----	3		
9422-3936-39-----	19				
		Variable resistor			
9422-4716-32-----	3	9472-1529-38-----	19		
9422-4736-39-----	19	9472-1539-38-----	19		
9422-5616-32-----	3	9472-2049-38-----	19		
9422-5636-39-----	19				
9422-6806-32-----	19	Condenser			
9422-6816-32-----	3	9531-1575-61-----	19		
9422-6836-39-----	19	9531-2265-31-----	19		
9422-8216-32-----	3, 19	9531-3365-61-----	19		
		9531-4765-31-----	19		

XG-1(n) CODE No. 2007-300

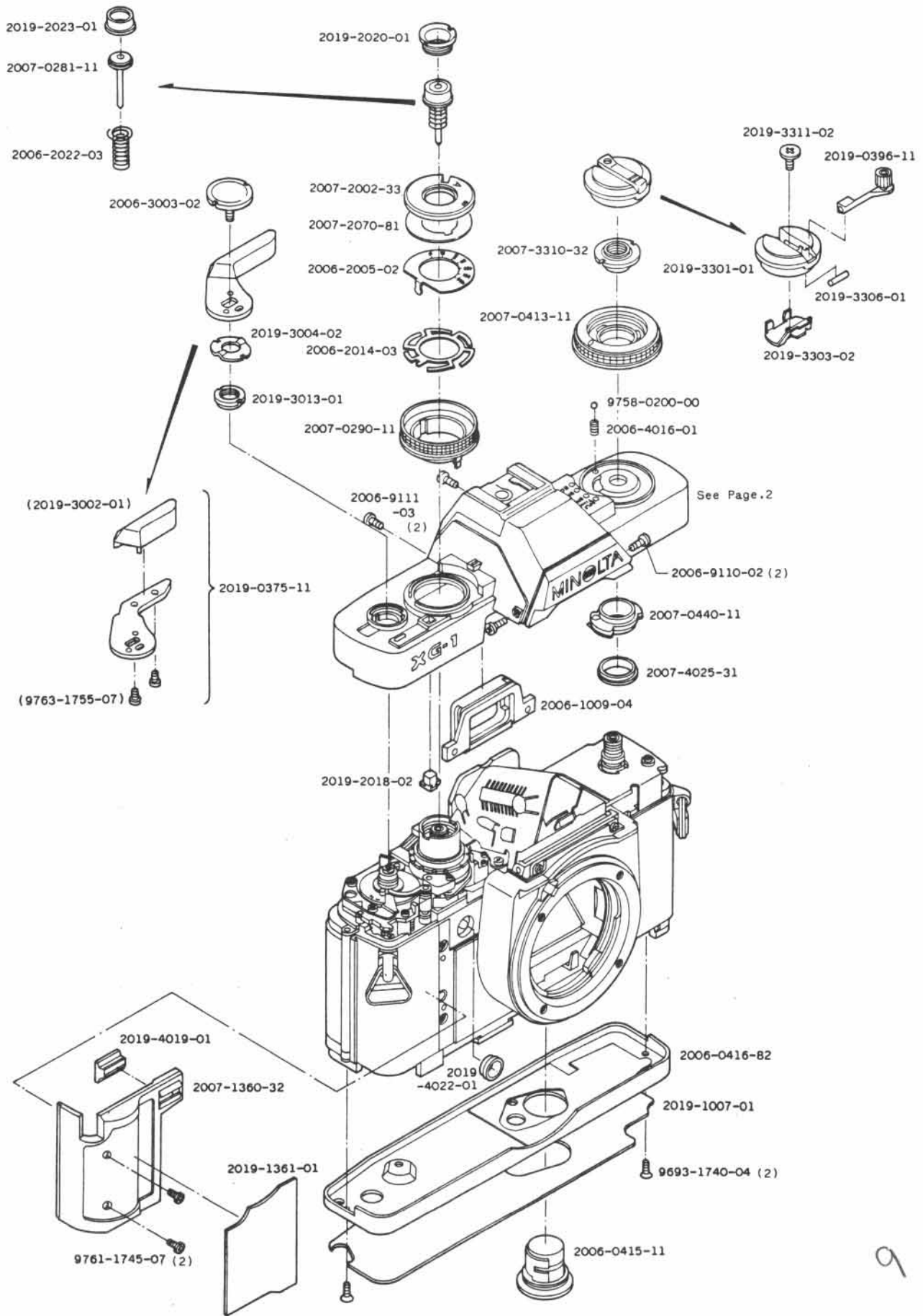

Part No.	Part Name	Qty
※2007-0281-11	Shutter release button set	シャッター鉤軸セット 1
※2007-0290-11	Shutter speed dial/Function selector	シャッターダイヤルセット 1
2019-0375-11	Film advance lever set	巻上レバーセット 1
(2019-3002-01)	Film advance lever knob	巻上レバー指当て 1
(9763-1755-07)	Tap tite screw	十字穴付半丸皿頭タップタイトねじ 2
2019-0396-11	Rewinding handle set	巻戻しハンドルセット 1
※2007-0413-11	Self-timer dial set	セルフダイヤルセット 1
2006-0415-11	Battery holder set	電池ケース蓋セット 1
2006-0416-82	Bottom cover set	下カバーセット 1
※2007-0440-11	Self-timer contact set	セルフ切換接片セット 1
2019-1007-01	Sheet	下カバー用保護シート 1
2006-1009-04	Eye-piece frame	接眼枠 1
※2007-1360-32	Grip	グリップ 1
2019-1361-01	Grip leather	グリップ貼皮 1
※2007-2002-33	Shutter speed dial	スピードダイヤル銘板 1
2006-2005-02	ASA dial	ASA 銘板 1
2006-2014-03	ASA spring	ASA スプリング 1
2019-2018-02	Auto lock button	オートロック釦 1
2019-2020-01	Shutter release button pressure	シャッター釦押え 1
2006-2022-03	Shutter release button spring	シャッター釦スプリング 1
2019-2023-01	Shutter release button cap	シャッター釦キャップ 1
※2007-2070-81	Mylar sheet	マイラーシート 1
2006-3003-02	Winding lever pressure	巻上レバー押え 1
2019-3004-02	Winding lever friction	巻上レバーフリクション 1
2019-3013-01	Top cover nut	上カバー止めナット 1
2019-3301-01	Rewinding knob	巻戻しノブ 1
2019-3303-02	Rewinding handle spring	巻戻しバネ 1
2019-3306-01	Rewinding handle axis	巻戻しハンドル軸 1
※2007-3310-32	Top cover pressure nut	上カバー押えナット 1
2019-3311-02	Rewinding knob screw	巻戻しノブビス 1
2006-4016-01	Self-timer dial click spring	セルフダイヤルクリックSP 1
2019-4019-01	Self-timer window	セルフ表示窓 1
2019-4022-01	Reflection ring	セルフ表示反射環 1
※2007-4025-31	Contact receiver	セルフ切換接片受 1
2006-9110-02	Screw-A	特殊止めビス 2
2006-9111-03	Screw-B	特殊止めビス 2
9693-1740-04	Phillips type tapping screw	十字穴付半丸皿頭タッピングねじ 2
9761-1745-07	Tap tite screw	十字穴付なべ頭タップタイトねじ 2
9758-0200-00	Steel ball	スチールボール 1

※:Parts for only 2007-300 (XG-1n)

※印は2007-300 (XG-1n) 専用部品

XG-I(n) CODE No. 2007-300

Assy. Part No. 2007-0170-11

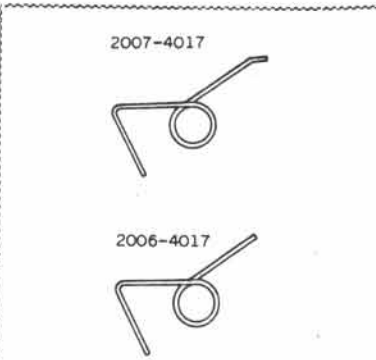
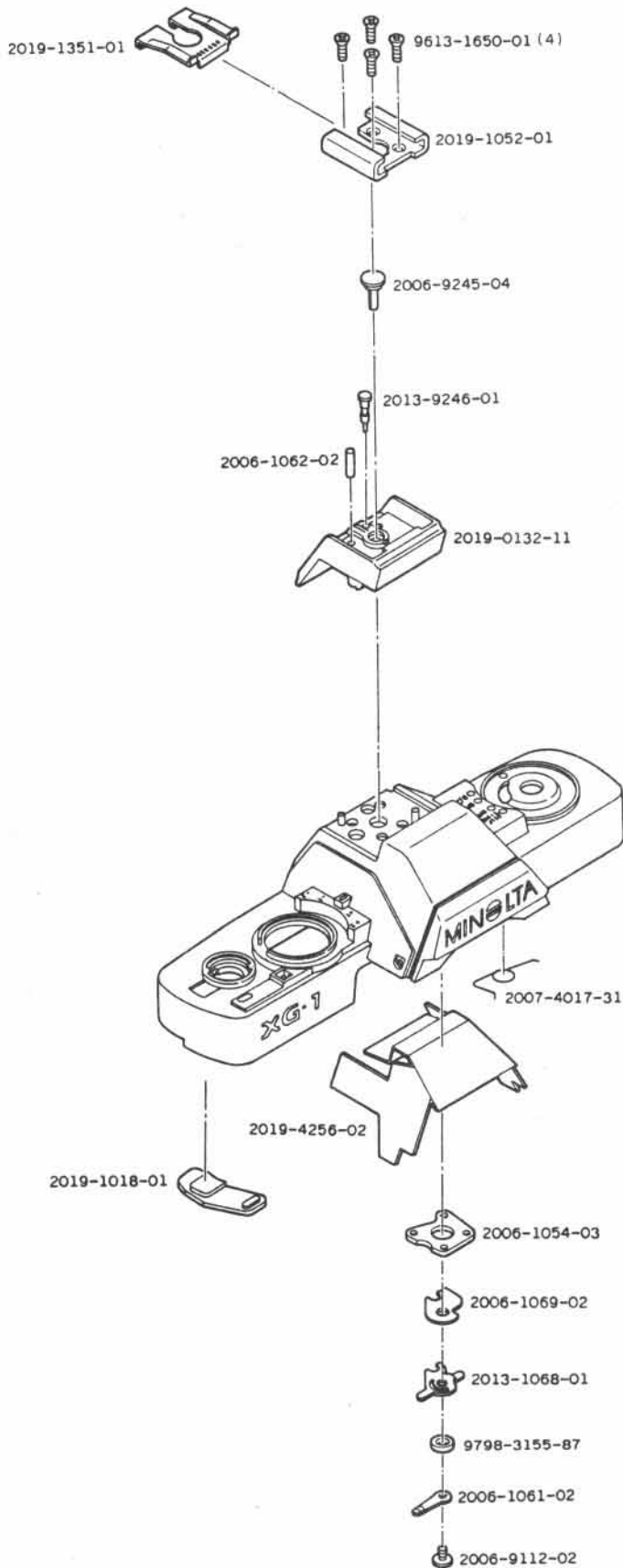

The self-timer return spring (2007-4017) is exclusive part for 2007-300, not exchangeable with 2006-4017.

セルフダイヤル戻しSPは2007-300専用部品となっておりますので、部品交換の際は注意して下さい。

Part No.	Part Name		Qty
※2007-0170-11	Top cover set	上カバーセット	1
2019-0132-11	Accessory shoe base set	アクセサリーシュー座	1
2019-1018-01	Counter window	カウンター窓	1
2019-1052-01	Accessory shoe	アクセサリーシュー	1
2006-1054-03	Accessory shoe set plate	アクセサリーシュー取付板	1
2006-1061-02	Contact-D	コンタクト接片D	1
2006-1062-02	Counter operation pin	コンタクト接片連動ピン	1
2013-1068-01	Contact-E	コンタクト接片E	1
2006-1069-02	Contact isolation sheet	コンタクト接片絶縁シート	1
2019-1351-01	Accessory shoe spring	アクセサリーシューバネ	1
※2007-4017-31	Self-timer reutrn spring	セルフダイヤル戻しSP	1
2019-4256-02	Top cover isolation sheet	上カバー絶縁シート	1
2006-9112-02	Contact pressure screw	止めビス	1
2006-9245-04	Contact-A	コンタクト接点A	1
2013-9246-01	Contact-B	コンタクト接点B	1
9613-1650-01	Phillips type screw	十字穴付半丸皿頭小ねじ	4
9798-3155-87	Washer	薄ワッシャー	1

※:Parts for only 2007-300(XG-1n)

※印は2007-300 (XG-1n) 専用部品

XG-I (n) CODE No. 2007-300

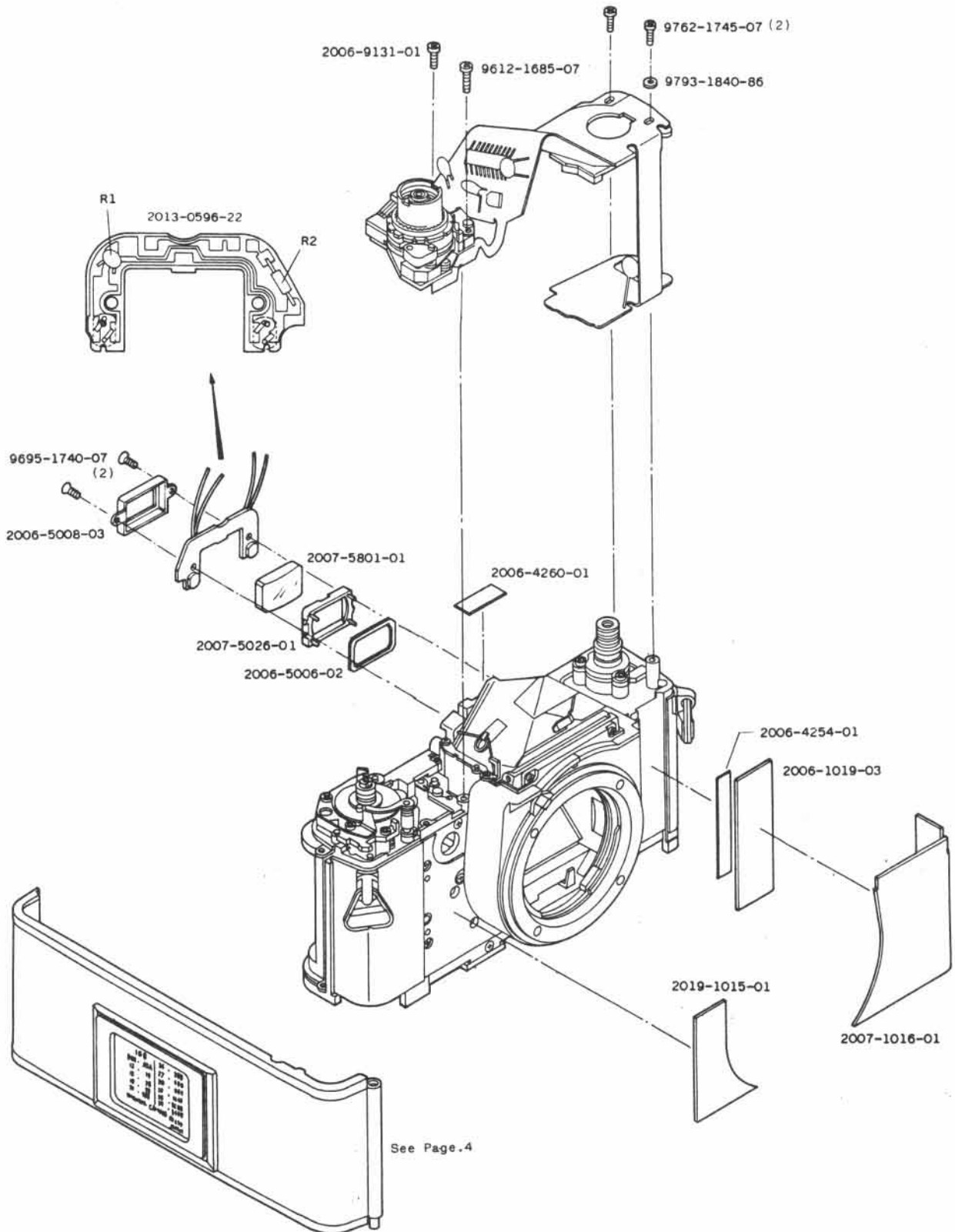

See Page.4

13

Part No.	Part Name		Qty
2013-0596-22	CdS circuit base plate set	CdS基板セット	1
2019-1015-01	Right side leather	ボデー貼皮 (右)	1
2007-1016-01	Left side leather	ボデー貼皮 (左)	1
2006-1019-03	Body leather	ボデー貼板	1
2006-4254-01	Tape-A(5x45mm)	フレキ接着テープ	1
2006-4260-01	Isolation tape-A(4.5x15mm)	絶縁紙	1
2006-5006-02	Eye-piece lens light shield frame	接眼レンズ遮光枠	1
2006-5008-03	Eye-piece lens pressure	接眼レンズ押え	1
2007-5026-01	Eye-piece lens holder	接眼レンズホルダー	1
2007-5801-01	Eye-piece lens	接眼レンズ	1
2006-9131-01	Screw	特殊止めビス	1
9612-1685-07	Phillips type screw	十字穴付なべ頭小ねじ	1
9695-1740-07	Phillips type tapping screw	十字穴付皿頭タッピングねじ	2
9762-1745-07	Tap tite screw	十字穴付なべ頭タップタイトねじ	1
9793-1840-86	Washer	薄ワッシャー	1

Symbol	Part No.	Part Name	Type.	Qty.
R1	9431-3347-31	Fixed resistor	1/16W, 330K Ω	} 1
	9431-3947-31		1/16W, 390K Ω	
	9431-4747-31		1/16W, 470K Ω	
	9431-5647-31		1/16W, 570K Ω	
	9431-6847-31		1/16W, 680K Ω	
	9431-8247-31		1/16W, 820K Ω	
	9431-1057-31		1/16W, 1M Ω	
	9431-1257-31		1/16W, 1.2M Ω	
	9431-1557-31		1/16W, 1.5M Ω	
R2	9422-1516-32	Fixed resistor	1/8W, 150 Ω	} 1
	9422-2216-32		1/8W, 220 Ω	
	9422-2716-32		1/8W, 270 Ω	
	9422-3316-32		1/8W, 330 Ω	
	9422-3916-32		1/8W, 390 Ω	
	9422-4716-32		1/8W, 470 Ω	
	9422-5616-32		1/8W, 560 Ω	
	9422-6816-32		1/8W, 680 Ω	
	9422-8216-32		1/8W, 820 Ω	
	9422-1026-32		1/8W, 1K Ω	
	9422-1226-32		1/8W, 1.2K Ω	
	9422-1526-32		1/8W, 1.5K Ω	
			9422-1826-32	

XG-I_(n) **CODE No. 2007-300**

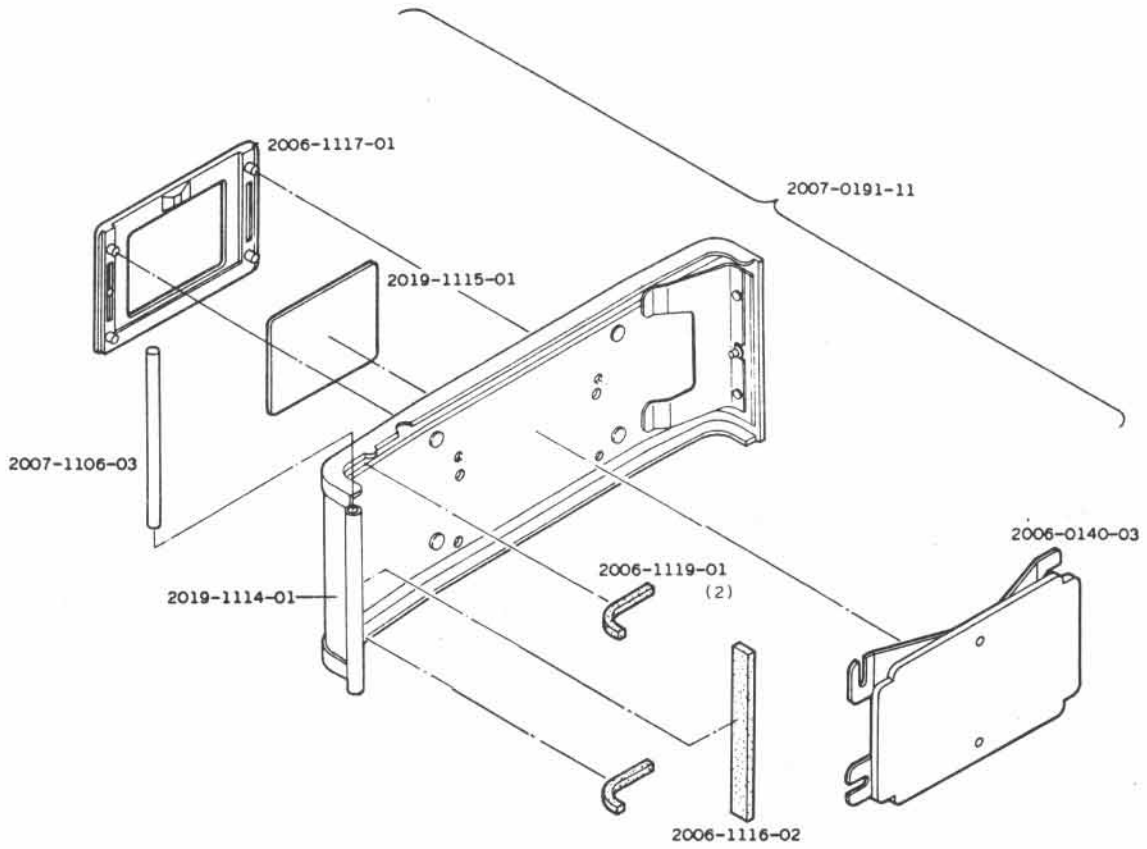

15

Part No.	Part Name		Qty
※ 2007-0191-11	Back cover set	裏蓋セット	1
2007-1106-03	Hinge axis-A	ヒンジ軸 A	1
2019-1114-01	Back leather	裏蓋貼皮	1
2019-1115-01	Conversion scale	ASA.DIN 換算板	1
2006-1116-02	Light shield plate	裏蓋遮光片	1
2006-1117-01	Back cover pocket	裏蓋ポケセット	1
2006-1119-01	Light shield plate-B	裏蓋遮光片B	2
2006-0140-03	Pressure plate set	圧着板セット	1

※:Parts for only 2007-300 (XG-1n)

※印は2007-300 (XG-1n) 専用部品

XG-I(n) CODE No. 2007-300

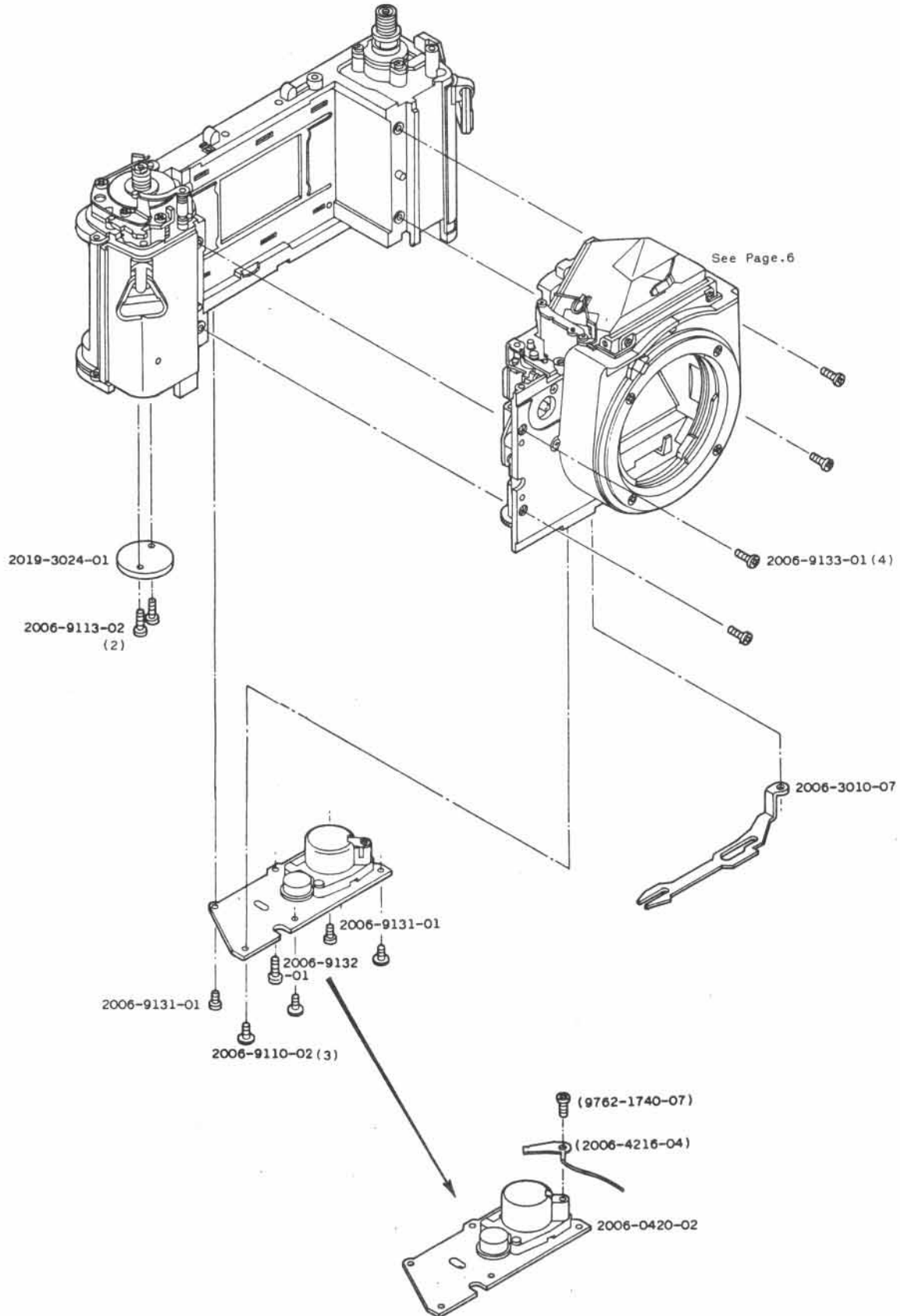

17

Part No.	Part Name		Qty
2006-0420-02	Battery case base plate set	電池ケース台板	1
(2006-4216-04)	Plus side contact	電池ケース接片 (+)	1
(9762-1740-07)	Tap tite screw	十字穴付なべ頭タップタイトねじ	1
2006-3010-07	Charge lever	チャージレバー	1
2019-3024-01	Winder coupler	ワインダーカプラー	1
2006-9110-02	Screw-A	止めビス	3
2006-9113-02	Screw	止めビス	2
2006-9131-01	Battery case set screw-A	止めビス	2
2006-9132-01	Battery case set screw-B	止めビス	1
2006-9133-01	Front base plate set screw	止めビス	4

XG-1(m) CODE No. 2007-300

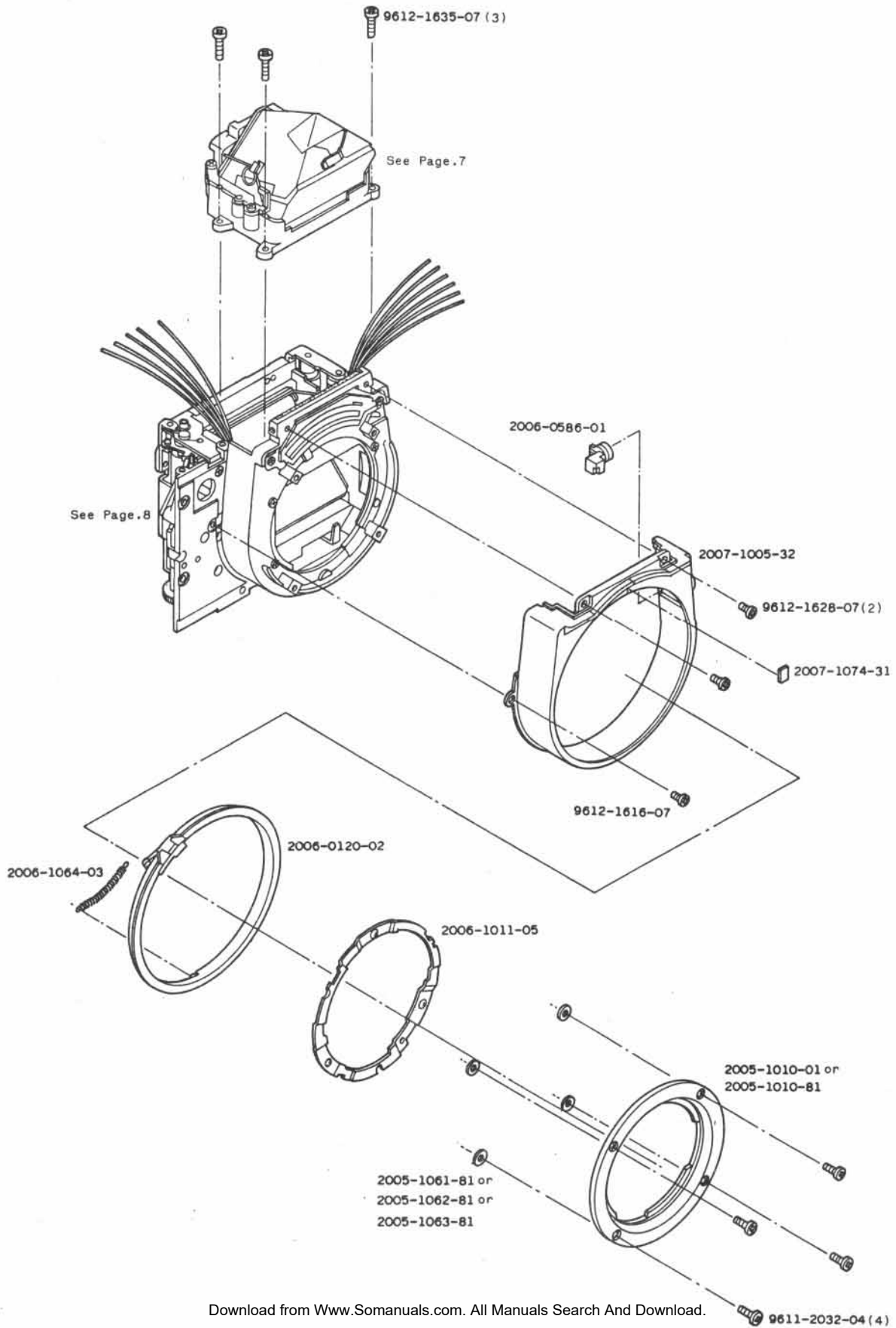

Part No.	Part Name		Qty
2006-0120-02	Aperture coupling ring set	連結リングセット	1
2006-0586-01	Lens lock button set	レンズロック釦セット	1
※2007-1005-32	Front cover	前カバー	1
2005-1010-01	Bayonet lens mount	バヨネット座板	1
2005-1010-81	Bayonet lens mount (-0.1mm)	バヨネット座板 (-0.1mm)	1
2006-1011-05	Bayonet spring	バヨネットスプリング	1
2005-1061-81	Adjustment washer-A t=0.02	調整ワッシャーA	} Some 若干
2005-1062-81	Adjustment washer-B t=0.05	調整ワッシャーB	
2005-1063-81	Adjustment washer-C t=0.1	調整ワッシャーC	
2006-1064-03	Aperture coupling ring spring	連結リングスプリング	1
※2007-1074-31	Front cover indication	前カバー指標	1
9611-2032-04	Phillips type screw	十字穴付なべ頭小ねじ	4
9612-1616-07	Phillips type screw	十字穴付なべ頭小ねじ	1
9612-1628-07	Phillips type screw	十字穴付なべ頭小ねじ	2
9612-1635-07	Phillips type screw	十字穴付なべ頭小ねじ	3

※Parts for only 2007-300 (XG-1n)

※印は2007-300 (XG-1n) 専用部品

XG-1 (n) CODE No. 2007-300

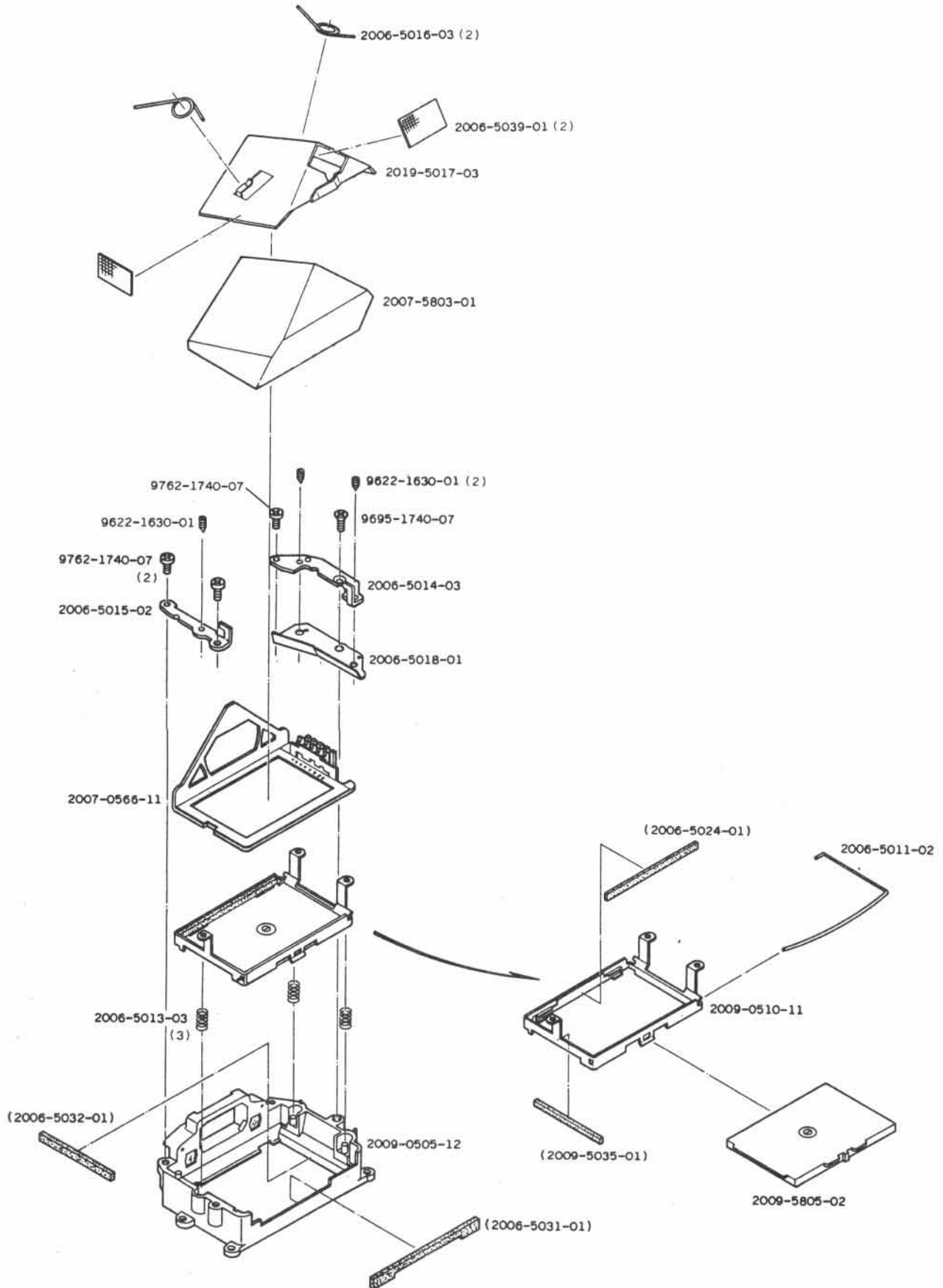

Part No.	Part Name		Qty
2009-0505-12	Penta. holder set	ペンターホルダーセット	1
(2006-5031-01)	Packing-A	防塵モルトブレンA	1
(2006-5032-01)	Packing-B	防塵モルトブレンB	1
2009-0510-11	Fresnel lens holder set	焦点板ホルダーセット	1
(2006-5024-01)	Packing-C	防塵モルトブレンC	1
(2009-5035-01)	Shield plate	防塵塩ビシート	1
※ 2007-0566-11	Penta. reciver set	ペンタ受セット	1
2006-5011-02	Fresnel lens pressure spring	焦点板押えSP	1
2006-5013-03	Fresnel lens holder spring	焦点板ホルダーSP	3
2006-5014-03	Penta. pressure (Left side)	ペンタ押え (左)	1
2006-5015-02	Penta. pressure (Right side)	ペンタ押え (右)	1
2006-5016-03	Penta. spring	ペンタ押えSP	2
2019-5017-03	Penta. pressure	ペンタ押え板	1
2006-5018-01	LED diffusion plate	LED 拡散板	1
2006-5039-01	Penta.pressure tape per meter	ペンタ押え板接着テープ	2
2007-5803-01	Penta. prism	ペンタプリズム	1
2009-5805-02	Fresnel lens	焦点板	1
9622-1630-01	Screw	トガリ先止めねじ	3
9762-1740-07	Tap tite screw	十字穴付なべ頭タップタイトねじ	3
9695-1740-07	Phillips type tapping screw	十字穴付皿頭タッピングねじ	1

※:Parts for only 2007-300(XG-1n)

※印は2007-300 (XG-1n) 専用部品

XG-I (n) CODE No. 2007-300

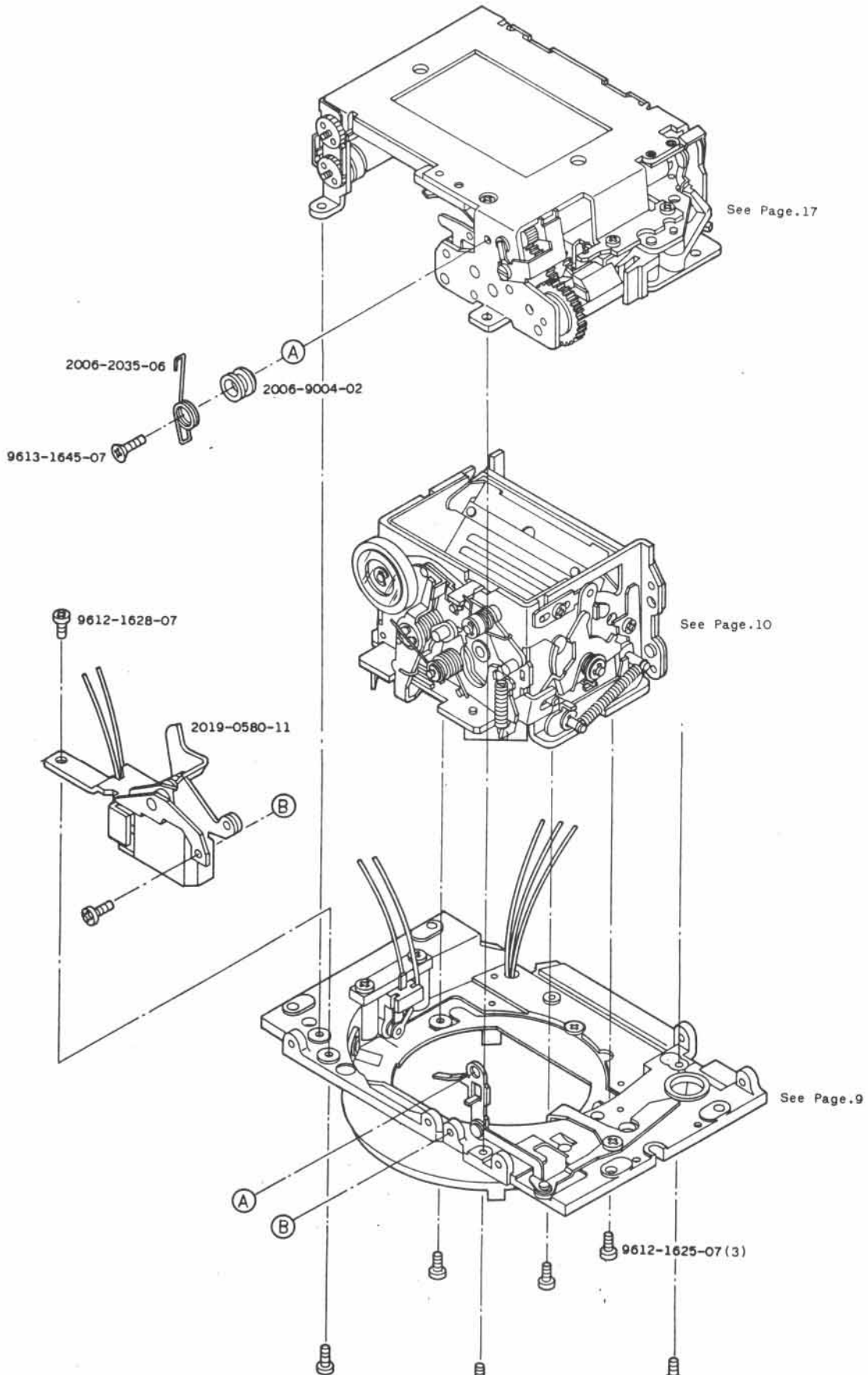

27

Part No.	Part Name		Qty
2019-0580-11	Magnetic release base plate set	リリースマグネット台板	1
2006-2035-06	Release operation lever spring	吸着用SP	1
2006-9004-02	Release operation lever A setscrew	リリース連結レバーA軸	1
9611-1625-07	Phillips type screw	十字穴付なべ頭小ねじ	3
9612-1625-07	Phillips type screw	十字穴付なべ頭小ねじ	3
9612-1628-07	Phillips type screw	十字穴付なべ頭小ねじ	2
9613-1645-07	Phillips type screw	十字穴付半丸皿頭小ねじ	1

XG-I(n) CODE No. 2007-300

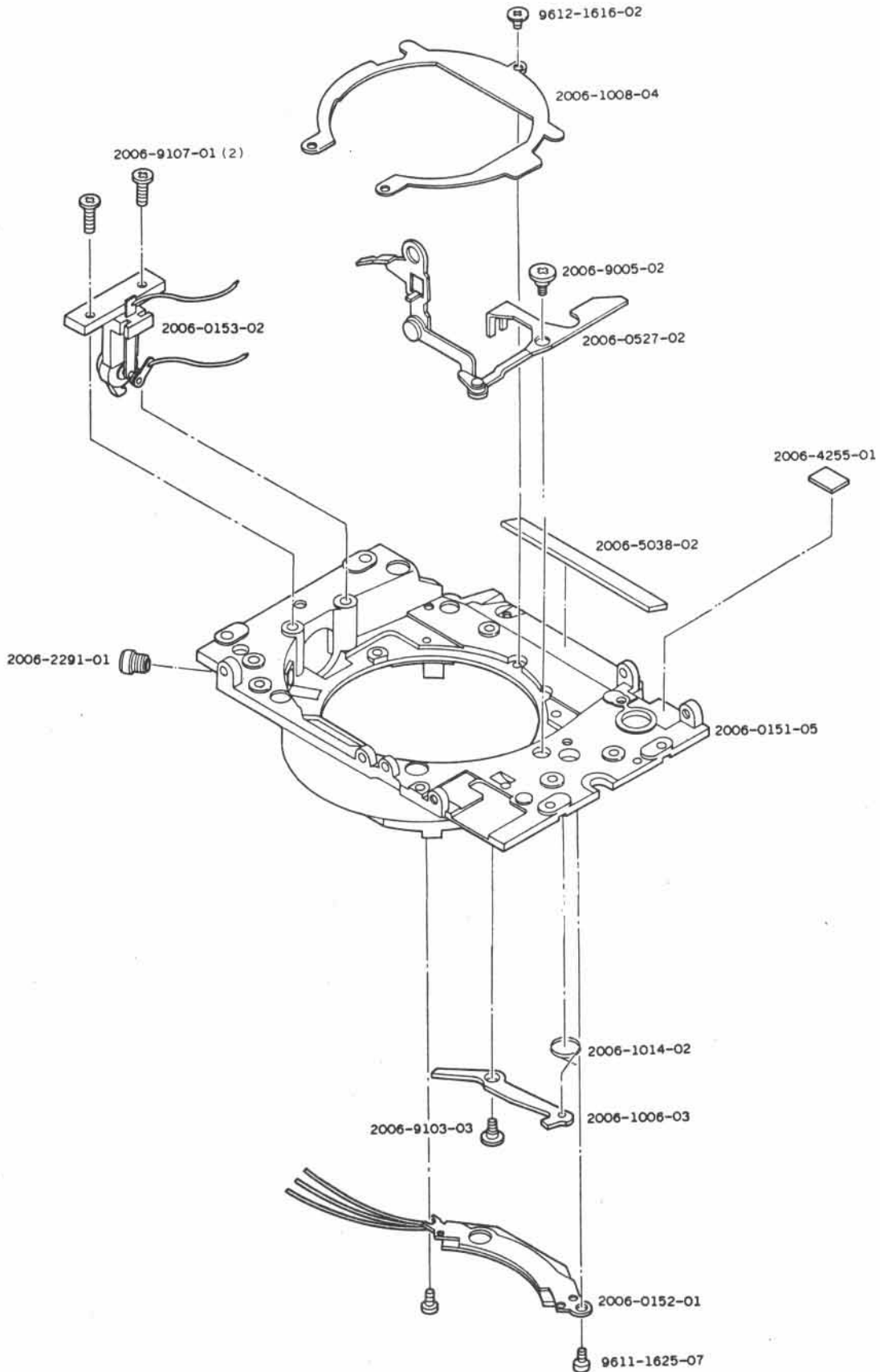

25

Part No.	Part Name		Qty
2006-0151-05	Front base plate set	前枠セット	1
2006-0152-01	Av resistor set	回路基板Bセット	1
2006-0153-02	Remote control base plate set	リモコン接片基板セット	1
2006-0527-02	Release operation lever-A set	リリース連結レバーセット	1
2006-1006-03	Lens lock lever	レンズロックレバー	1
2006-1008-04	Mirror box light shield plate	ミラーボックス遮光板	1
2006-1014-02	Lock lever spring	ロックレバーSP	1
2006-2291-01	Synchro terminal set	シンクロターミナル	1
2006-4255-01	Tape A (3.8X8)	テープ A	1
2006-5038-02	Pneta. front packing	ベント前面押えクッション	1
2006-9005-02	Release operation lever-C set screw	止めねじ	1
2006-9103-03	Lens lock axis	レンズロック軸	1
2006-9107-01	Screw-D	止めねじ	2
9612-1616-02	Phillips type screw	十字穴付なべ頭小ねじ	1
9611-1625-07	Phillips type screw	十字穴付なべ頭小ねじ	2

XG-I(n) CODE No. 2007-300

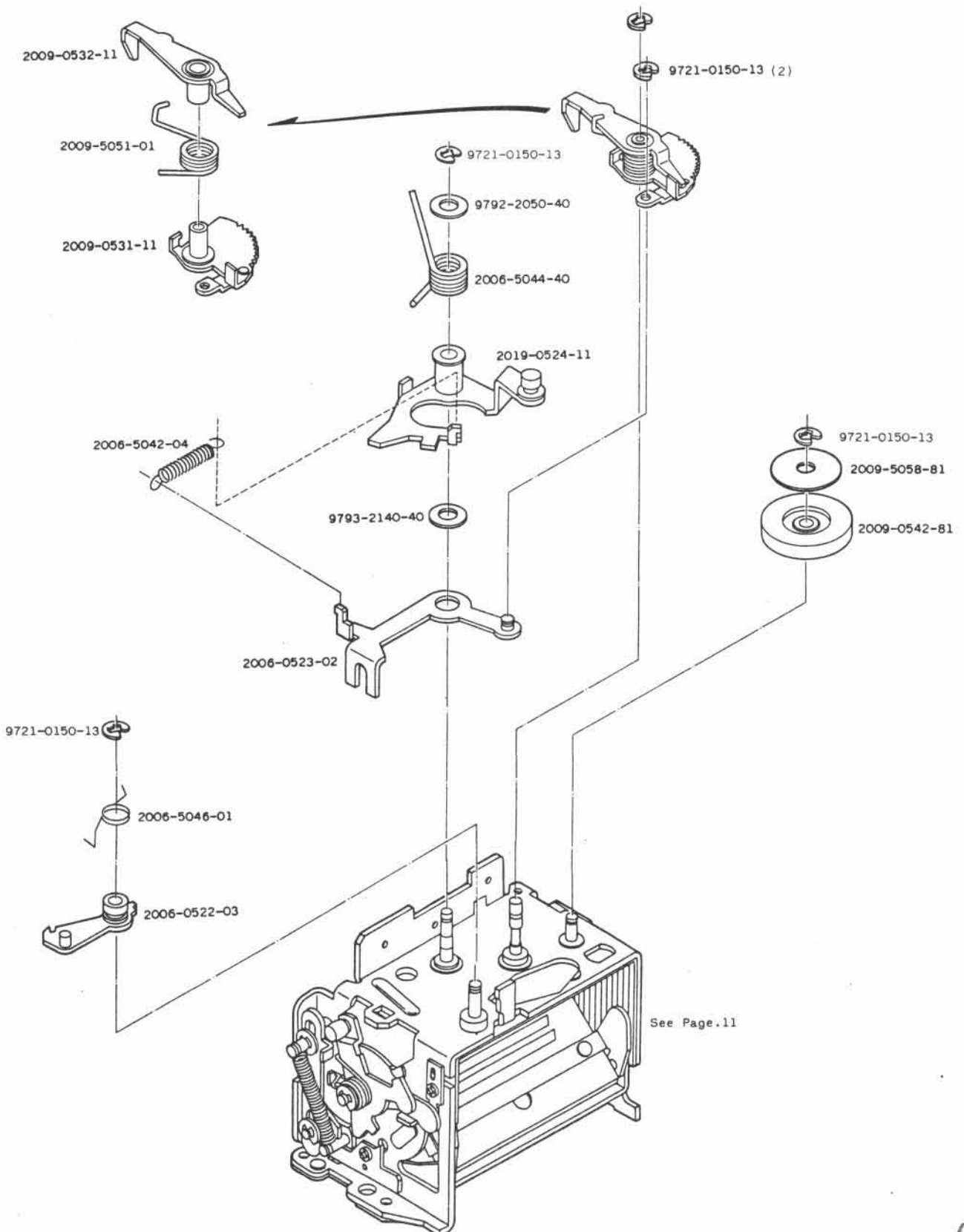

27

Part No.	Part Name		Qty
2006-0522-03	Mirror return lever lock claw set	ミラー戻しレバーロック爪	1
2006-0523-02	Preset operation lever set	プリセット連動レバー ^{セット}	1
2019-0524-11	Mirror return lever set	ミラー戻しレバーセット	1
2009-0531-11	Preset operation plate set	プリセット作動板	1
2009-0532-11	Preset lever set	プリセットレバー	1
2009-0542-81	Fly wheel gear set	フライホールギヤー	1
2006-5042-04	Mirror-up spring	ミラーアップSP	1
2006-5044-40	Mirror return spring	ミラー戻しSP	1
2006-5046-01	Lock claw spring	ロック爪スプリング	1
2009-5051-01	Preset lever spring	プリセットレバーSP	1
2009-5058-81	Fly wheel washer	フライホイールワッシャー	1
9721-0150-13	E-ring	Eリング	5
9792-2050-40	Washer	薄ワッシャー	1
9793-2140-40	Washer	薄ワッシャー	1

XG-I(n) CODE No. 2007-300

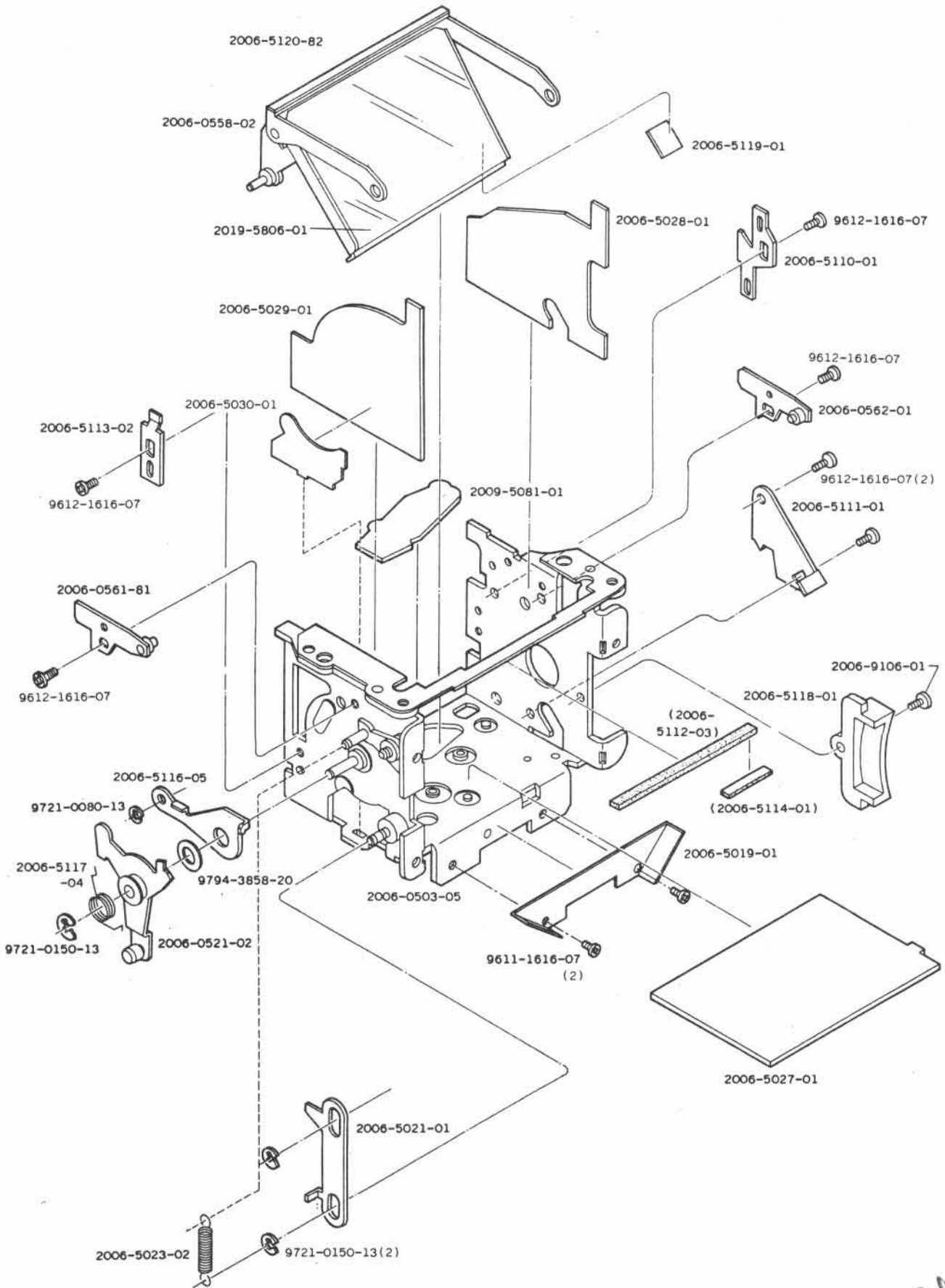

29

Part No.	Part Name		Qty
2006-0503-05	Mirror box set	ミラーボックスセット	1
(2006-5112-03)	Mirror cushion	ミラークッション	1
(2006-5114-01)	Mirror cushion-B	ミラークッションB	1
2006-0521-02	Mirror operation lever-set	ミラー操作レバーセット	1
2006-0558-02	Mirror holder set	ミラーホルダーセット	1
2006-0561-81	Operation lever-B base set (Right)	ミラー操作レバーB軸台セット (右)	1
2006-0562-01	Operation lever-B base set (Left)	ミラー操作レバーB軸台セット (左)	1
2006-5019-01	Mirror box apron	ミラーボックスエプロン	1
2006-5021-01	Mirror release lever	ミラーリリースレバー	1
2006-5023-02	Release lever spring	ミラーリリースレバーSP	1
2006-5027-01	Flare shield plate(bottom)	フレア防止シート (下)	1
2006-5028-01	Flare shield plate(Left side)	フレア防止シート (左)	1
2006-5029-01	Flare shield plate(Right side)	フレア防止シート (右)	1
2006-5030-01	Flare shield support plate	フレア防止シート補助板	1
2009-5081-01	Mirror box cover	ミラーボックス穴カバー	1
2006-5110-01	Mirror support stopper-A	ミラー補助ストッパーA	1
2006-5111-01	Mirror stopper	ミラーストッパー	1
2006-5113-02	Mirror support stopper-B	ミラー補助ストッパーB	1
2006-5116-05	Mirror operation lever-B	ミラー作動レバー	1
2006-5117-04	Mirror operation lever spring	ミラー操作レバーSP	1
2006-5118-01	Mirror box light shield palte	ミラーボックス遮光片	1
2006-5119-01	Mirror stopper gum	ミラーストッパーゴム	1
2006-5120-82	Mirror arm cushion	ミラーアームクッション	1
2019-5806-01	Mirror	ミラー	1
2006-9106-01	Screw-C	止めビス	1
9611-1616-07	Phillips type screw	十字穴付なべ頭小ねじ	2
9612-1616-07	Phillips type screw	十字穴付なべ頭小ねじ	6
9721-0080-13	E-ring	Eリング	1
9721-0150-13	E-ring	Eリング	3
9794-3858-20	Washer	薄ワッシャー	1

XG-I(n) CODE No. 2007-300

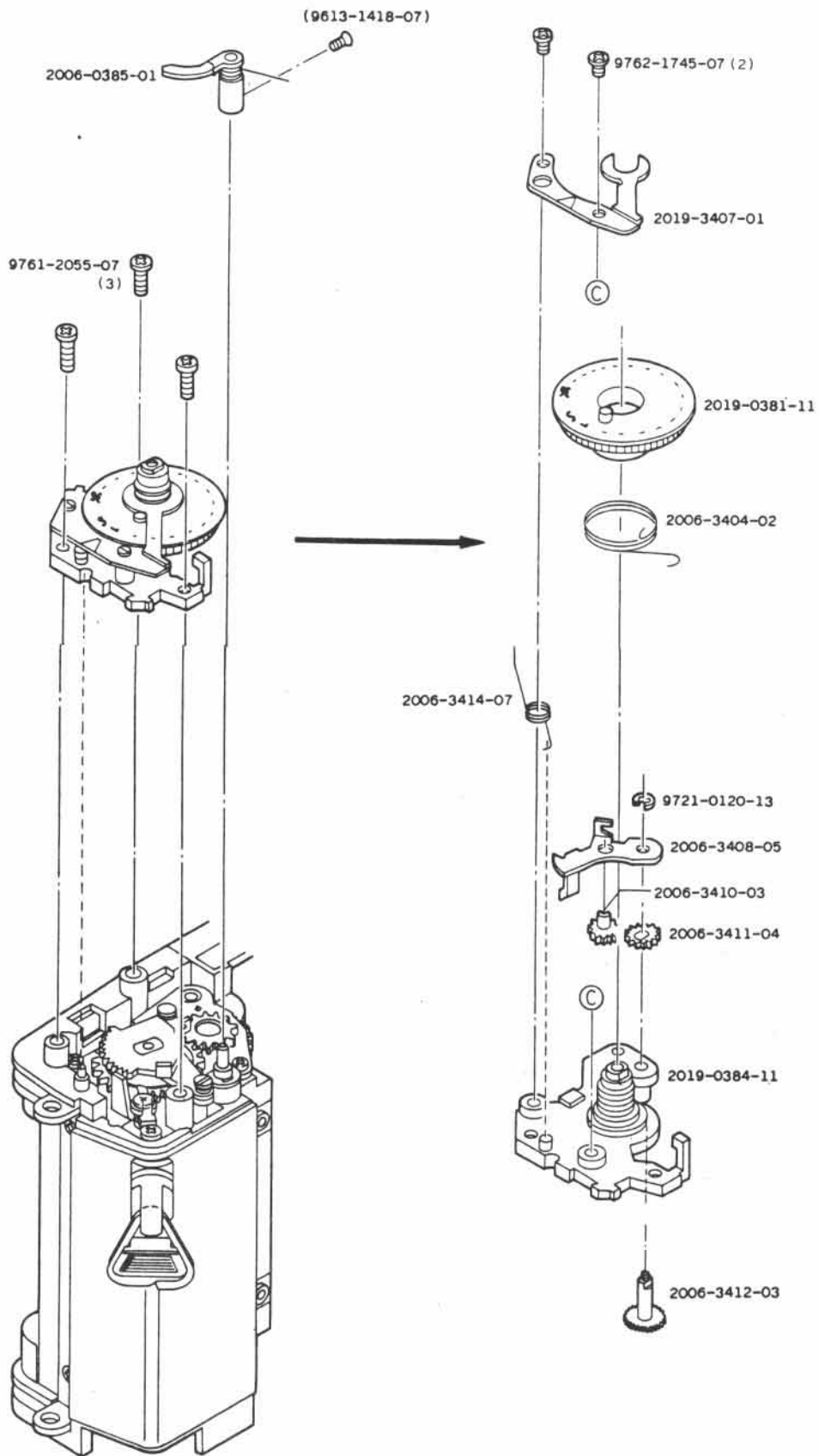

31

Part No.	Part Name		Qty
2019-0381-11	Counter dial set	カウンターダイヤルセット	1
2019-0384-11	Winding base palte-B set	巻取台板Bセット	1
2006-0385-01	Film indication lever axis set	フィルム表示レバーセット	1
(9613-1418-07)	Phillips type screw	十字穴付半丸皿頭小ねじ	1
2006-3404-02	Counter return spring	カウンター戻しSP	1
2019-3407-01	Counter index	カウンター指標	1
2006-3408-05	Counter operation lever	カウンター駆動操作レバー	1
2006-3410-03	Counter operation gear-B set	カウンター駆動ギヤー	1
2006-3411-04	Counter operation gear-C set	カウンター伝達ギヤー	1
2006-3412-03	Counter operation gear-A	カウンター連結ギヤー	1
2006-3414-07	Return lever spring	ゼロリターンSP	1
9761-2055-07	Tap tite screw	十字穴付なべ頭タップタイトねじ3	
9762-1745-07	Tap tite screw	十字穴付なべ頭タップタイトねじ2	
9721-0120-13	E-ring	Eリング	1

XG-I(n) CODE No. 2007-300

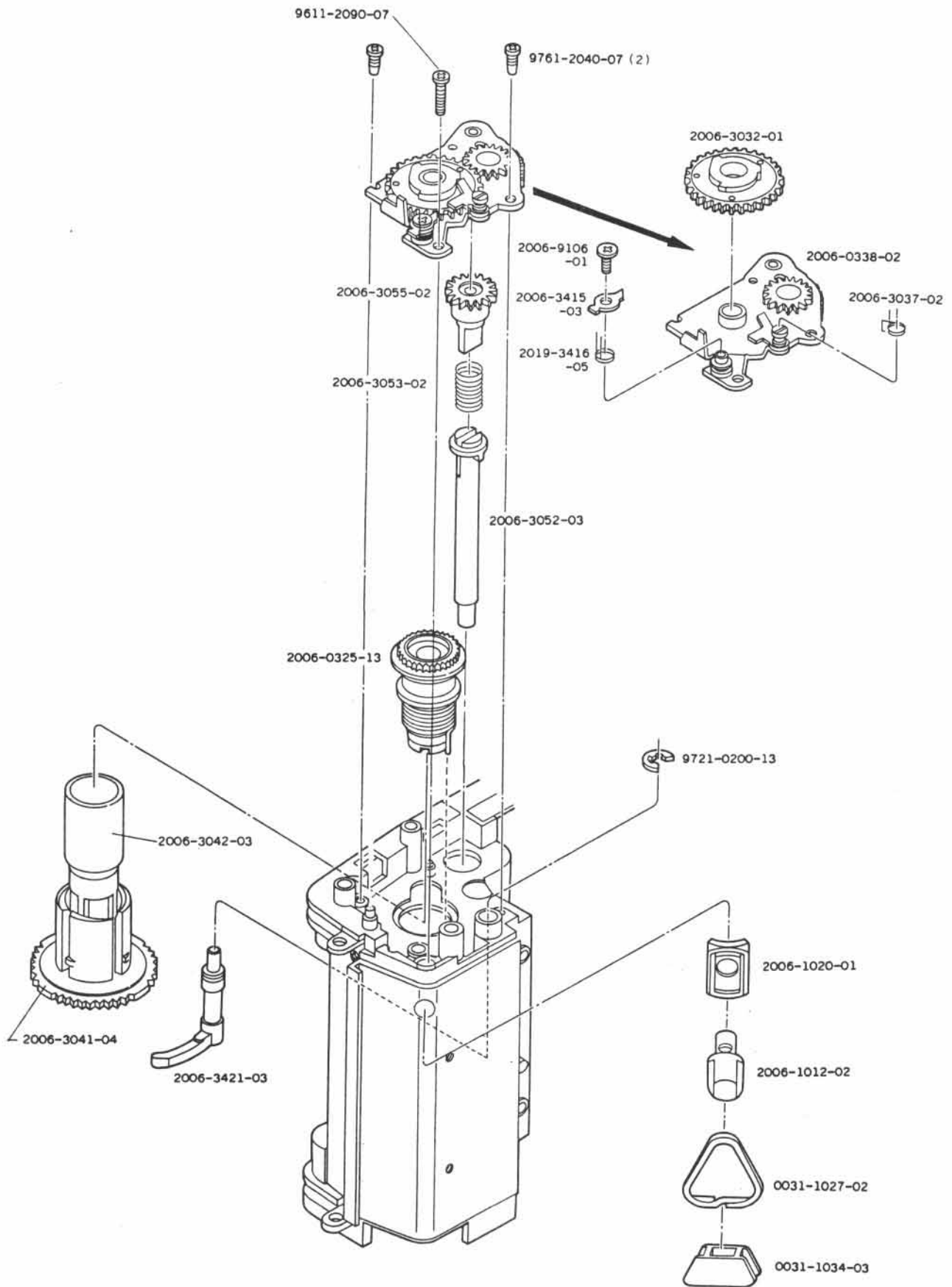

Part No.	Part Name		Qty
2006-0325-13	Spool gear set	スプールギヤーセット	1
2006-0338-02	Winding base plate-A set	巻取台板 A セット	1
2006-1012-02	Strap hanger	吊環	1
2006-1020-01	Strap hanger seat	吊環座	1
0031-1027-02	Triangle hanger	三角吊環	1
0031-1034-03	Triangle hanger stopper	三角環回り止め	1
2006-3032-01	Winding gear	巻取ギヤー	1
2006-3037-02	Reversing stop claw spring	逆転防止爪SP	1
2006-3041-04	Spool	スプール	1
2006-3042-03	Spool inner barrel	スプール内筒	1
2006-3052-03	Sprocket shaft	スプロケット軸	1
2006-3053-02	R button release spring	R 釦解除SP	1
2006-3055-02	Sprcket gear	スプロケットギヤー	1
2006-3415-03	Winding operation lever-A	トンボ返りレバー	1
2019-3416-05	Winding operation lever spring	トンボ返りレバー-SP	1
2006-3421-03	Film indication filler	フィルム表示ファイラー	1
2006-9106-01	Screw-C	止めねじ	1
9611-2090-07	Phillips type screw	十字穴付なべ頭小ねじ	1
9761-2040-07	Tap tite screw	十字穴付なべ頭タップタイトねじ	2
9721-0200-13	E-ring	E リング	1

XG-I(n) CODE No. 2007-300

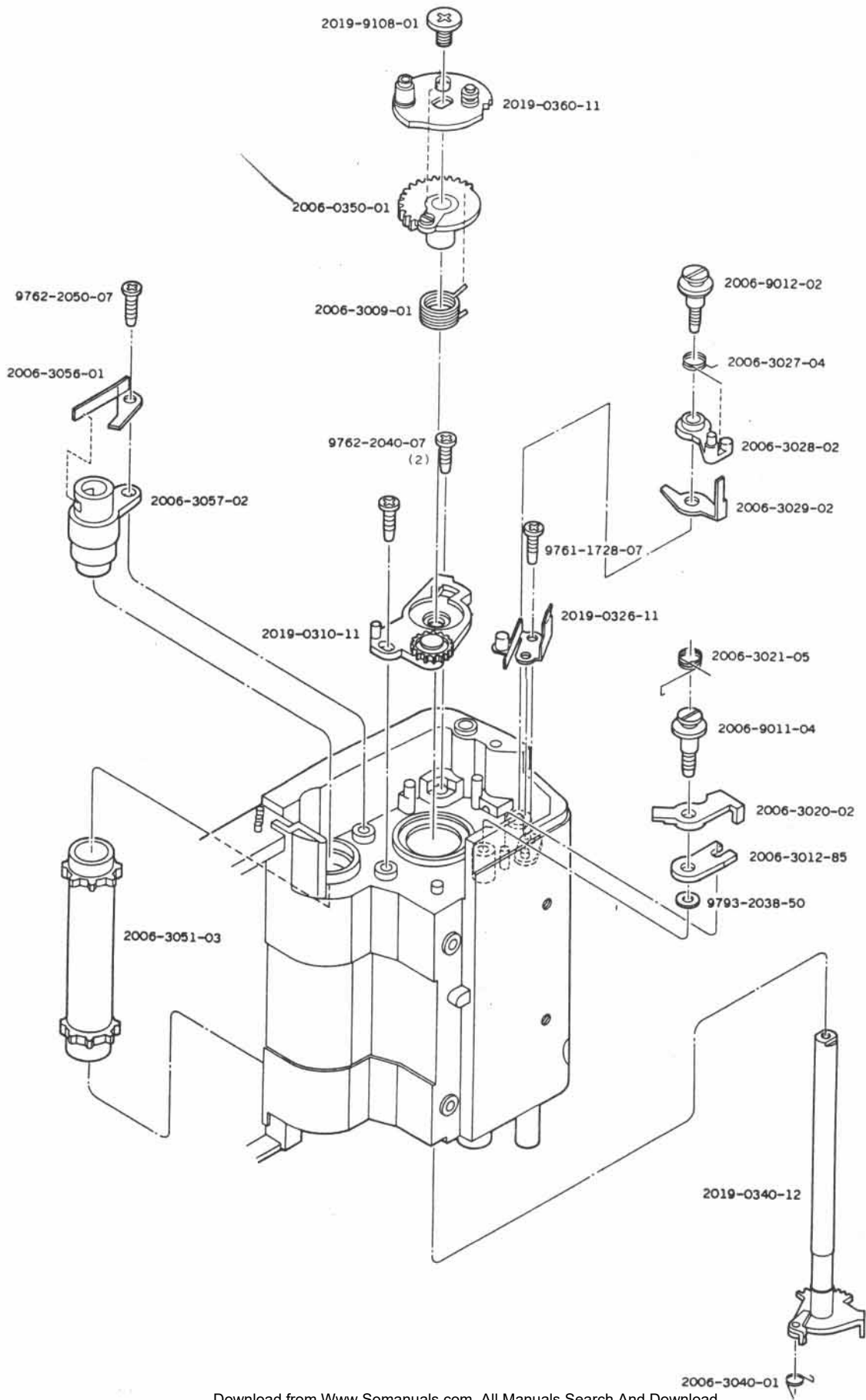

Part No.	Part Name		Qty
2019-0310-11	Winding axis receiver set	巻取軸受セット	1
2019-0326-11	S4 contact set	S4 接片セット	1
2019-0340-12	Winding operation plate set	巻取操作板セット	1
2006-0350-01	Shutter charge gear-D set	シャッターチャージギヤーセット	1
2019-0360-11	Charge operation plate set	チャージ操作板セット	1
2006-3009-01	Return spring	戻しSP	1
2006-3012-85	Winding stop lever	巻止めレバー	1
2006-3020-02	Reset lever	リセットレバー	1
2006-3021-05	Reset lever spring	リセットレバースプリング	1
2006-3027-04	S4 spring	S4 SP	1
2006-3028-02	S4 change lever	S4 切換レバー	1
2006-3029-02	S4 lug plate	S4 ラグ板	1
2006-3040-01	Widning claw spring	巻取爪SP	1
2006-3051-03	Sprocket	スプロケット	1
2006-3056-01	R button lock spring	R鈕ロックSP	1
2006-3057-02	Sprocket receiver	スプロケット軸受	1
2006-9011-04	Winding stop lever axis	巻止めレバー軸	1
2006-9012-02	S4 change lever axis	S4 切換レバー軸	1
2019-9108-01	Screw	止めねじ	1
9761-1728-07	Tap tite screw	十字穴付なべ頭タップタイトねじ	1
9762-2040-07	Tap tite screw	十字穴付なべ頭タップナイトねじ	2
9762-2050-07	Tap tite screw	十字穴付なべ頭タップタイトねじ	1
9793-2038-50	Washer	薄ワッシャー	1

XG-I(n) CODE No. 2007-300

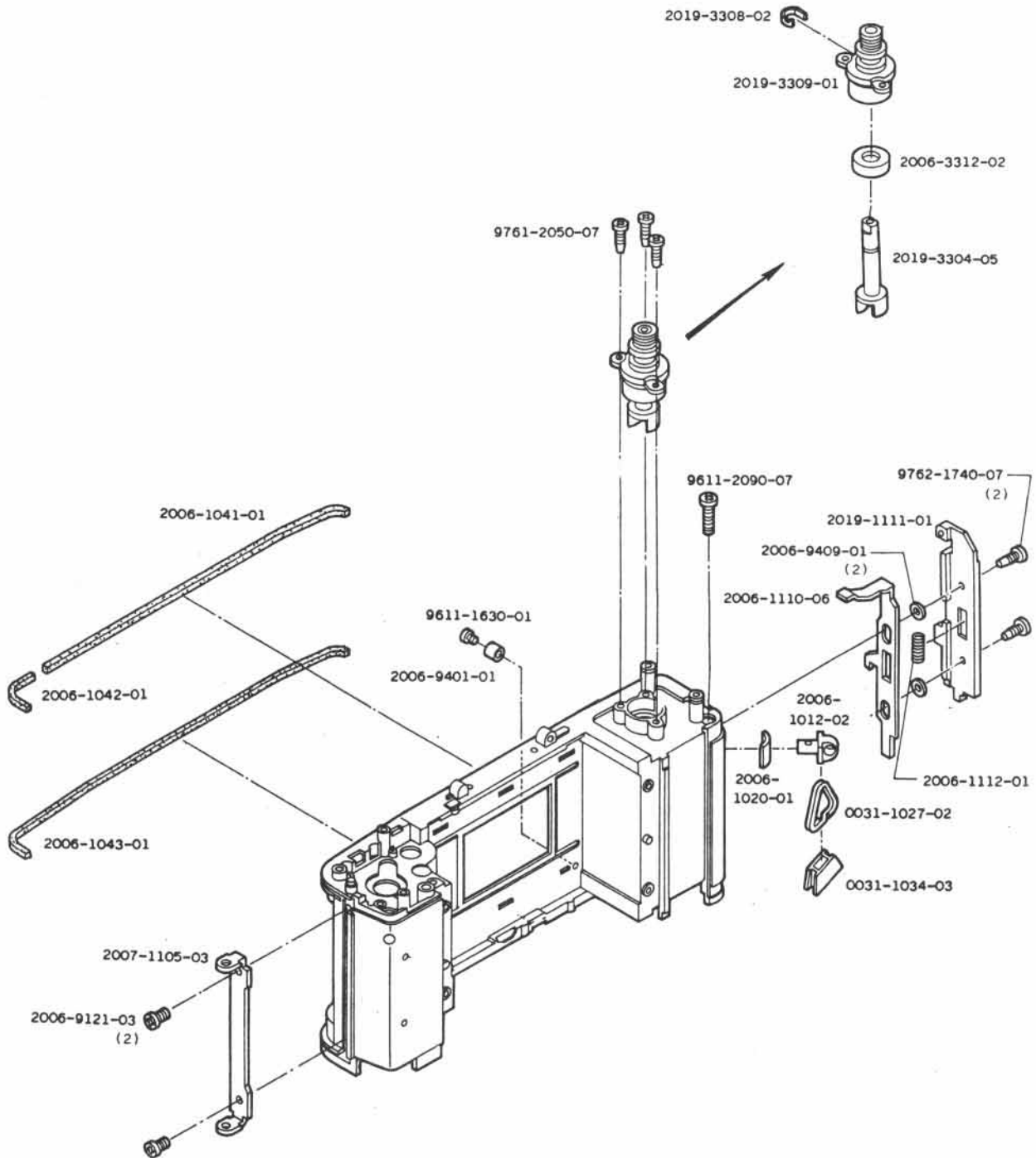

37

Part No.	Part Name		Qty
2006-1012-02	Strap hanger	吊環	1
2006-1020-01	Strap hanger seat	吊環座	1
0031-1027-02	Triangle hanger	三角吊環	1
0031-1034-03	Triangle hanger stopper	三角環回り止め	1
2006-1041-01	Light shield packing-A	遮光パッキンA	1
2006-1042-01	Light shield packing-B	遮光パッキンB	1
2006-1043-01	Light shield packing-C	遮光パッキンC	1
2007-1105-03	Hinge	ヒンジ	1
2006-1110-06	Back cover lock lever	裏蓋ロックレバー	1
2019-1111-01	Lock cover	ロックカバー	1
2006-1112-01	Back cover lock spring	裏蓋ロックSP	1
2019-3304-05	Rewinding fork	巻戻しフオーク	1
2019-3308-02	Rewinding friction spring	巻戻しフリクションSP	1
2019-3309-01	Rewinding axis receiver	巻戻し軸受	1
2006-3312-02	Light shield collar	巻戻し遮光カラー	1
2006-9121-03	Tapping screw	止めねじ	2
2006-9401-01	Film guide collar	フィルムガイドカラー	1
2006-9409-01	Back cover lock guide	裏蓋ロックガイド	2
9611-1630-01	Phillips type screw	十字穴付なべ頭小ねじ	1
9611-2090-07	Phillips type screw	十字穴付なべ頭小ねじ	1
9761-2050-07	Tap tite screw	十字穴付なべ頭タップタイトねじ	3
9762-1740-07	Tap tite screw	十字穴付なべ頭タップタイトねじ	2

XG-I (n) CODE No. 2007-300

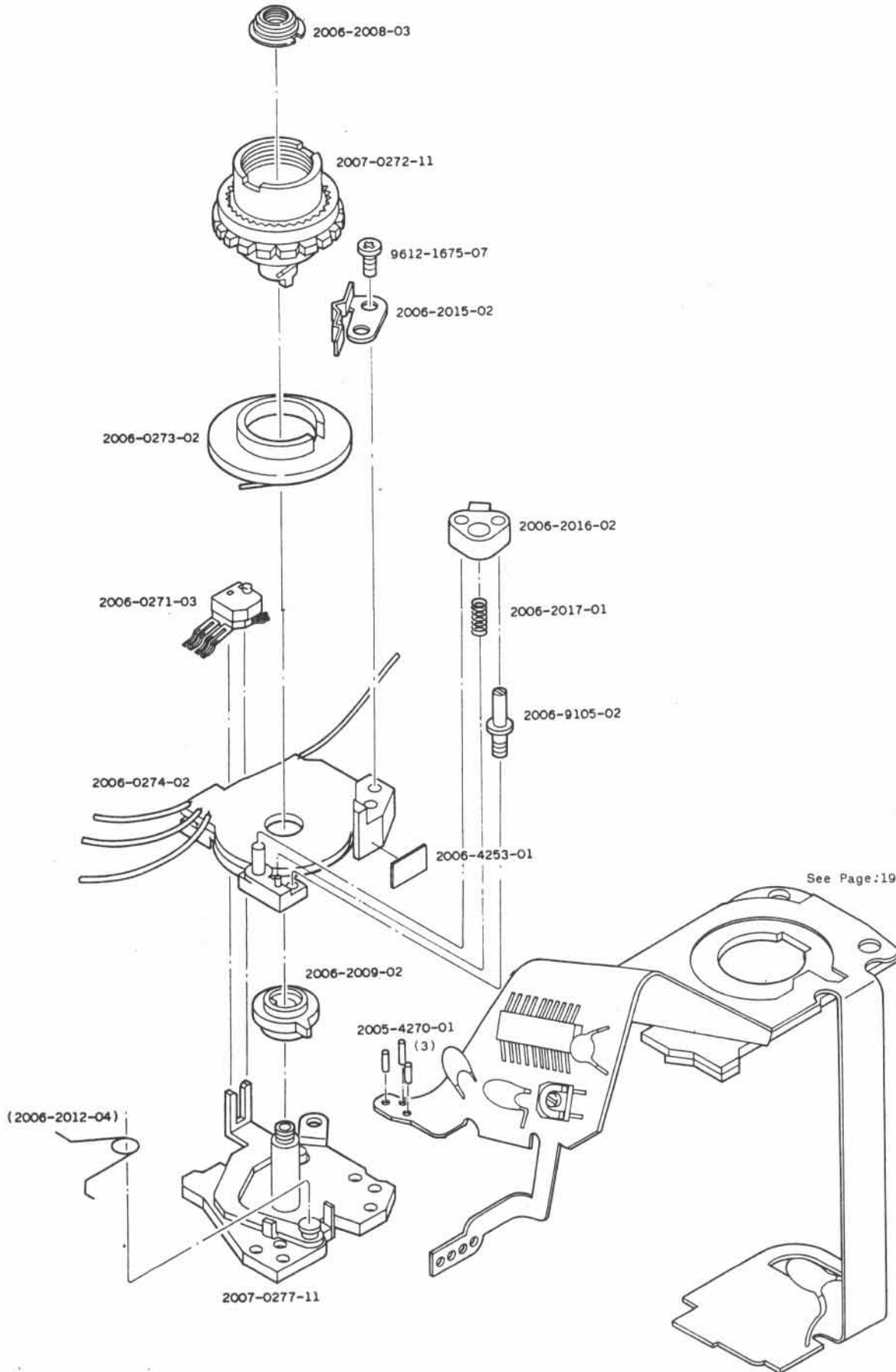

39

Part No.	Part Name		Qty
2006-0271-03	AM change holer set	AM切換ホルダーセット	1
※ 2007-0272-11	Dial axis set	ダイヤル軸セット	1
2006-0273-02	ASA brush holder set	ASAブラシホルダーセット	1
2006-0274-02	ASA resistor set	回路基板Aセット	1
※ 2007-0277-11	Shutter speed dial base plate set	シャッターダイヤル台板セット	1
(2006-2012-04)	AM change spring	AM切換SP	1
2006-2008-03	Shutter speed dial pressure	シャッターダイヤル押え	1
2006-2009-02	Cam plate	カム板	1
2006-2015-02	Click spring	クリックSP	1
2006-2016-02	Auto lock plate	オートロック板	1
2006-2017-01	Auto lock spring	オートロックSP	1
2006-4253-01	Tape-B	フレキ接着テープ	1
2005-4270-01	Jamp lead (φ0.4 ℓ=3mm)	ジャンプリード	3
2006-9105-02	Auto lock plate guide	オートロック板ガイド	1
9612-1675-07	Phillips type screw	十字穴付なべ頭小ねじ	1

※ :Parts for only 2007-300(XG-1n)

※印は2007-300 (XG-1n) 専用部品

XG-I(n) CODE No. 2007-300

Assy. Part No. 2006-0222-11

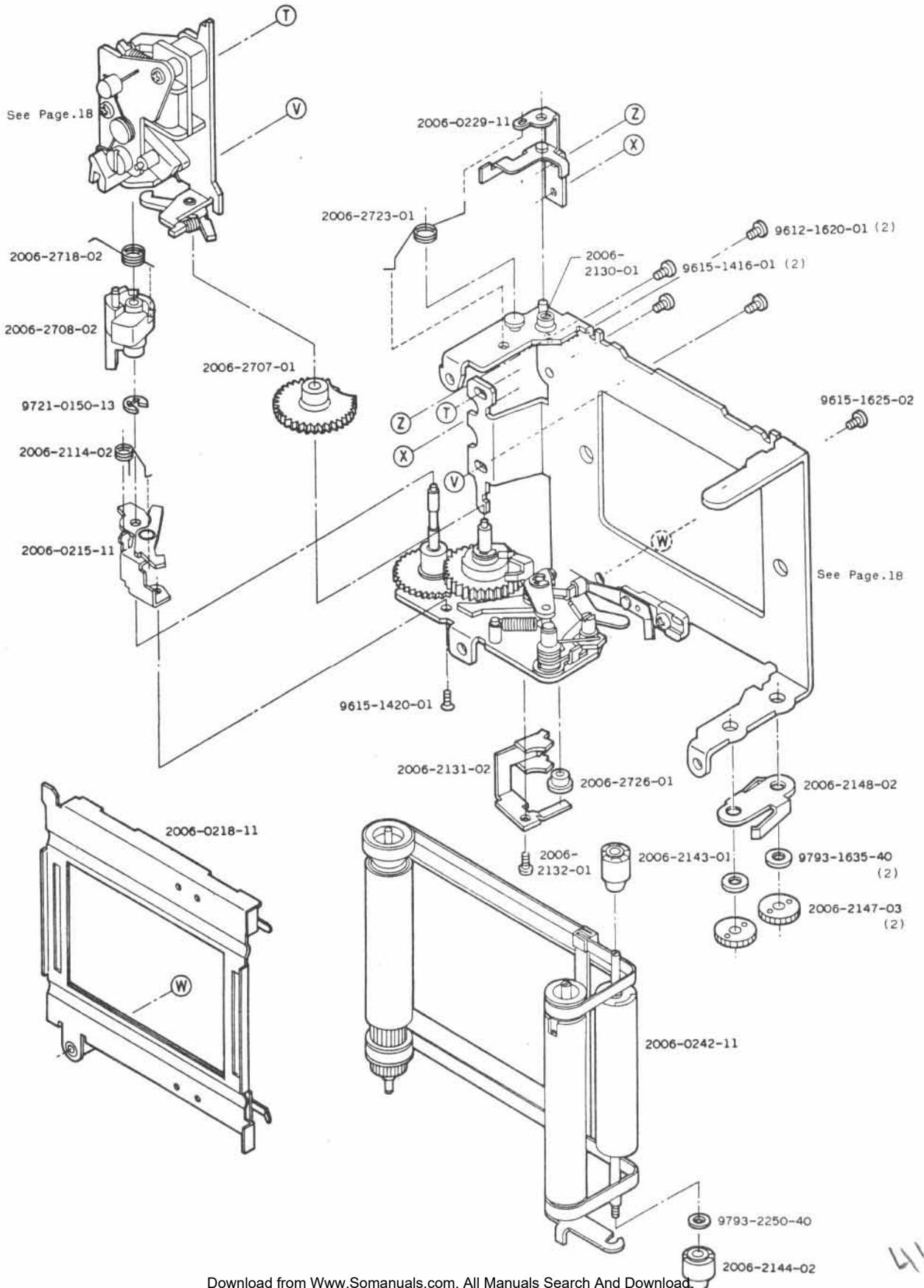

Part No.	Part Name		Qty
2006-0222-11	Shutter complete set	シャッターブロック	1
2006-0215-11	1st curtain stop lever set	一幕係止レバーセット	1
2006-0218-11	Shutter cover set	シャッターカバー板セット	1
2006-0229-11	2nd curtain stop lever set	二幕係止レバーセット	1
2006-0242-11	Shutter curtain set	シャッター幕セット	1
2006-2114-02	First curtain stop lever spring	一幕係止レバーSP	1
2006-2130-01	Adjusting screw	幕調整ねじ	1
2006-2131-02	Curtain ribbon guide plate	幕リボンガイド板	1
2006-2132-01	Ribbon guide plate screw	止めねじ	1
2006-2143-01	2nd curtain roller-A	二幕ローラーA	1
2006-2144-02	2nd curtain roller-B	二幕ローラーB	1
2006-2147-03	Ratchet	幕スプリング筒軸止めラチェット	2
2006-2148-02	Ratchet stop spring	ラチェット止めSP	1
2006-2707-01	2nd curatin shutter gear	二幕シャッターギヤー	1
2006-2708-02	Control cam	制御カム	1
2006-2718-02	Control cam operation spring	制御カム駆動SP	1
2006-2723-01	2nd curtain stop lever spring	二幕係止レバーSP	1
2006-2726-01	Curtain shaft receiver-B	幕軸受 B	1
9612-1620-01	Phillips type screw	十字穴付なべ頭小ねじ	2
9615-1416-01	Phillips type screw	十字穴付皿頭小ねじ	2
9615-1420-01	Phillips type screw	十字穴付皿頭小ねじ	1
9615-1625-02	Phillips type screw	十字穴付皿頭小ねじ	1
9721-0150-13	E-ring	Eリング	1
9793-1635-40	Washer	薄ワッシャー	2
9793-2250-40	Washer	薄ワッシャー	1

XG-I (n) CODE No. 2007-300

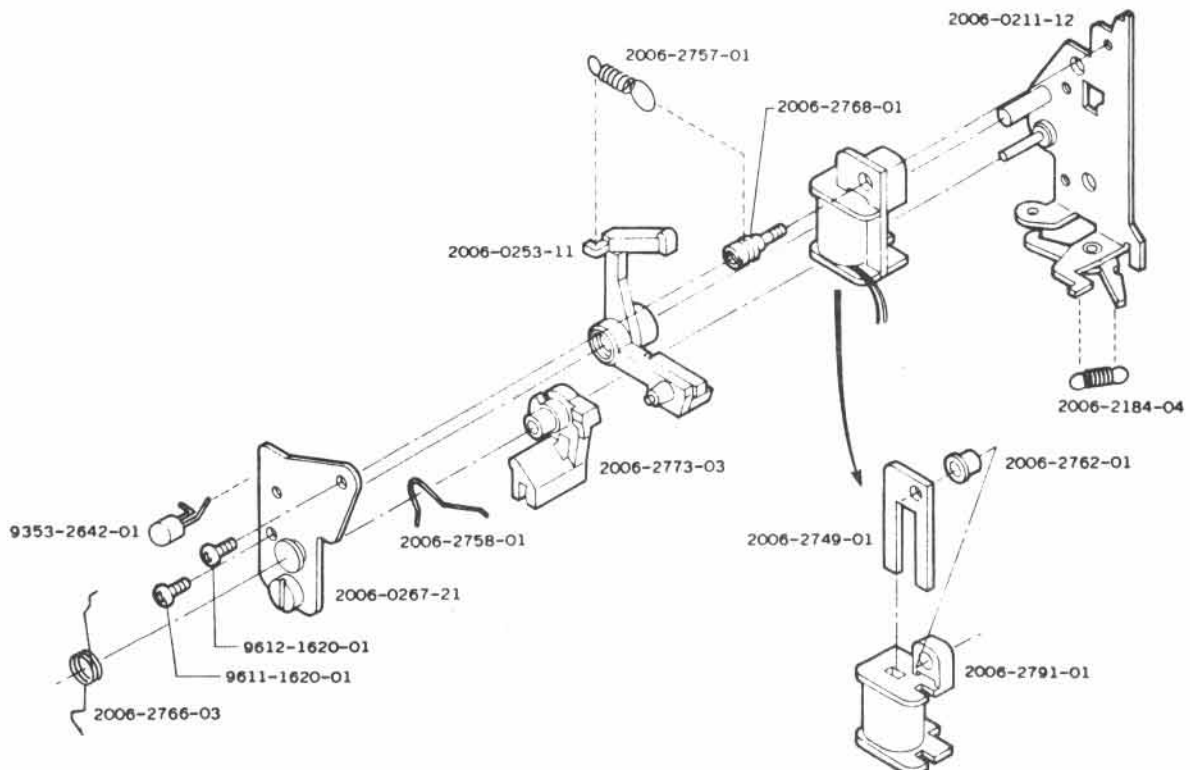
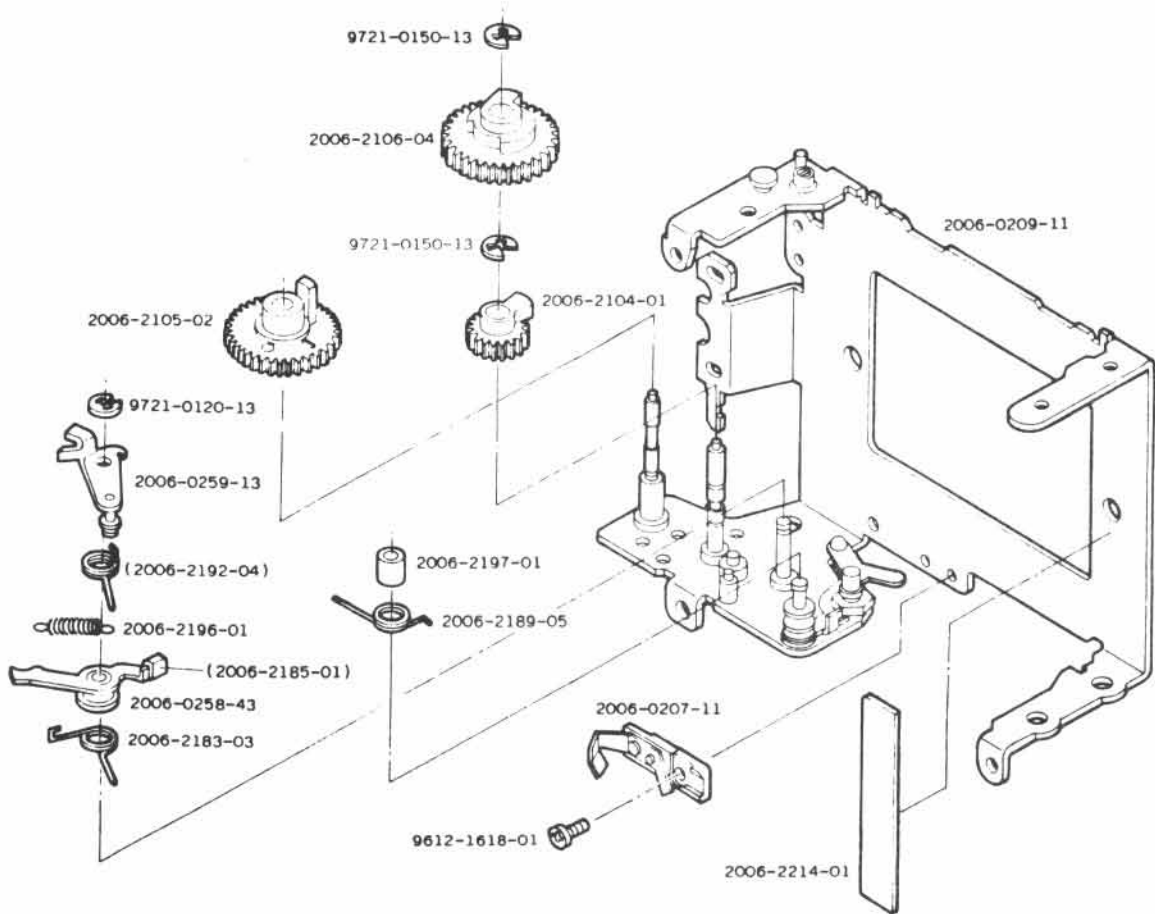

43

Part No.	Part Name		Qty
2006-0207-11	X contact plate set	X 接片セット	1
2006-0209-11	Shutter base plate set	シャッター台板セット	1
2006-0211-12	Control base plate set	制御台板セット	1
2006-0253-11	2nd curtain release lever set	二幕解除レバーセット	1
2006-0258-43	1st curtain brake lever set	一幕ブレーキレバーセット	1
(2006-2185-01)	Brake lever isolation collar	一幕ブレーキ絶縁カラー	1
2006-0259-13	2nd curtain brake lever set	二幕ブレーキレバーセット	1
(2006-2192-04)	2nd curtain brake spring	二幕ブレーキSP	1
2006-0267-21	Wiring base plate set	Mg 配線基板セット	1
2006-2104-01	Charge gear-B	チャージギヤ-B	1
2006-2105-02	Charge gear-A	チャージギヤ-A	1
2006-2106-04	1st curtain shutter gear	一幕シャッターギヤ	1
2006-2183-03	1st curtain brake spring-B	一幕ブレーキ SP-B	1
2006-2184-04	2nd curtain brake spring	制御カム係止レバーSP	1
2006-2189-05	X lever spring	X レバーSP	1
2006-2196-01	2nd curtain brake return spring	二幕ブレーキ戻しSP	1
2006-2197-01	Brake lever axis collar	二幕ブレーキ消音カラー	1
2006-2214-01	Tape	幕緑金保護テープ	1
2006-2749-01	Shutter magnet core	シャッターマグネット鉄芯	1
2006-2757-01	2nd curtain release lever spring	二幕解除レバーSP	1
2006-2758-01	Over charge spring	吸着片オーバーチャージSP	1
2006-2762-01	Magnet collar	マグネット取付カラー	1
2006-2766-03	Trigger contact	トリガー接片	1
2006-2768-01	Trigger base plate screw	止めねじ	1
2006-2773-03	Trigger contact operation lever	トリガー接片作動レバー	1
2006-2791-01	Shutter magnet bobbin	シャッターマグネットボビン	1
9611-1620-01	Phillips type screw	十字穴付なべ頭小ねじ	1
9612-1618-01	Phillips type screw	十字穴付なべ頭小ねじ	1
9612-1620-01	Phillips type screw	十字穴付なべ頭小ねじ	1
9721-0120-13	E-ring	E リング	1
9721-0150-13	E-ring	E リング	2
© 9353-2642-01	L.E.D (TLR108)	L.E.D (LD13)	1

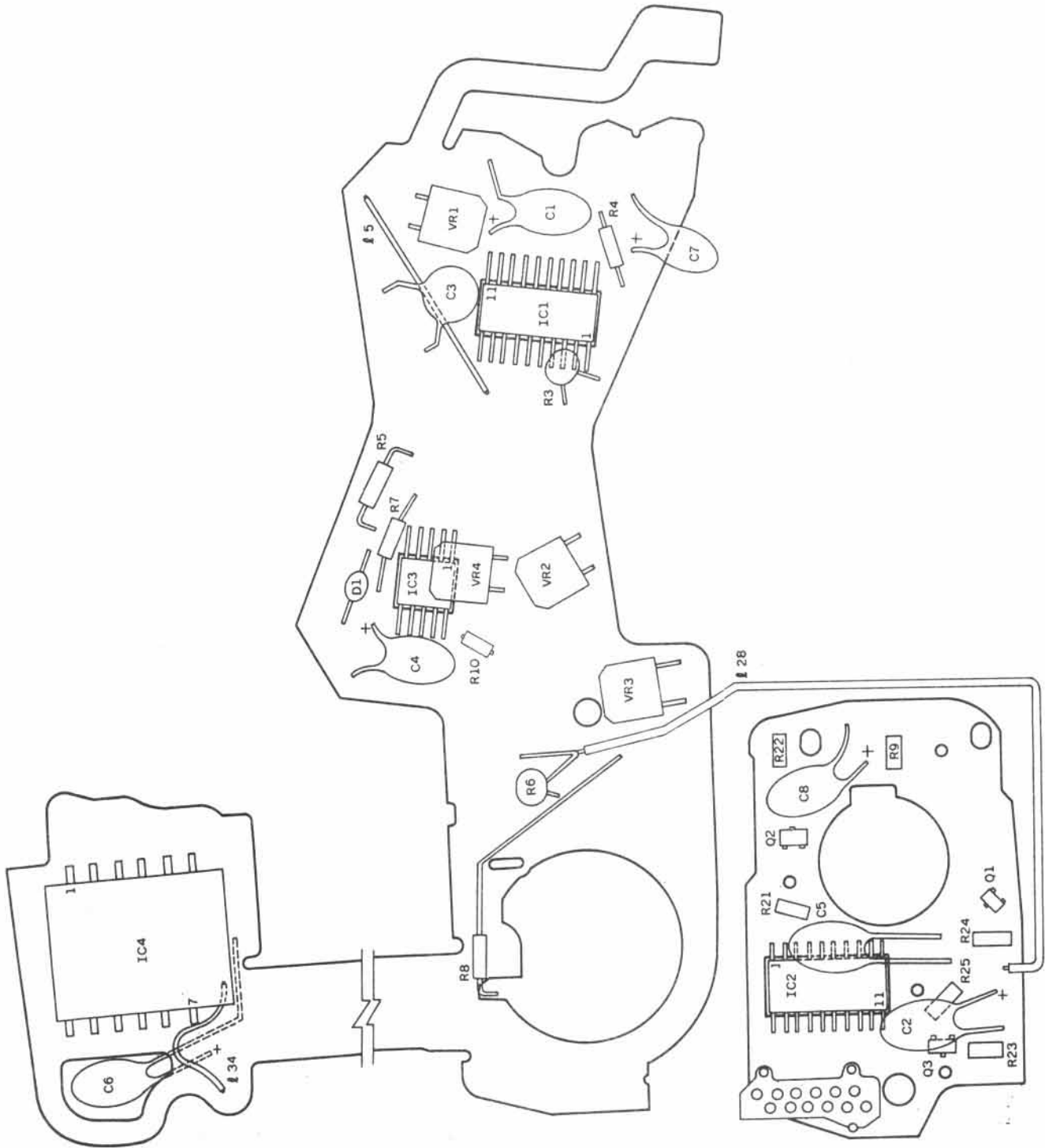

45

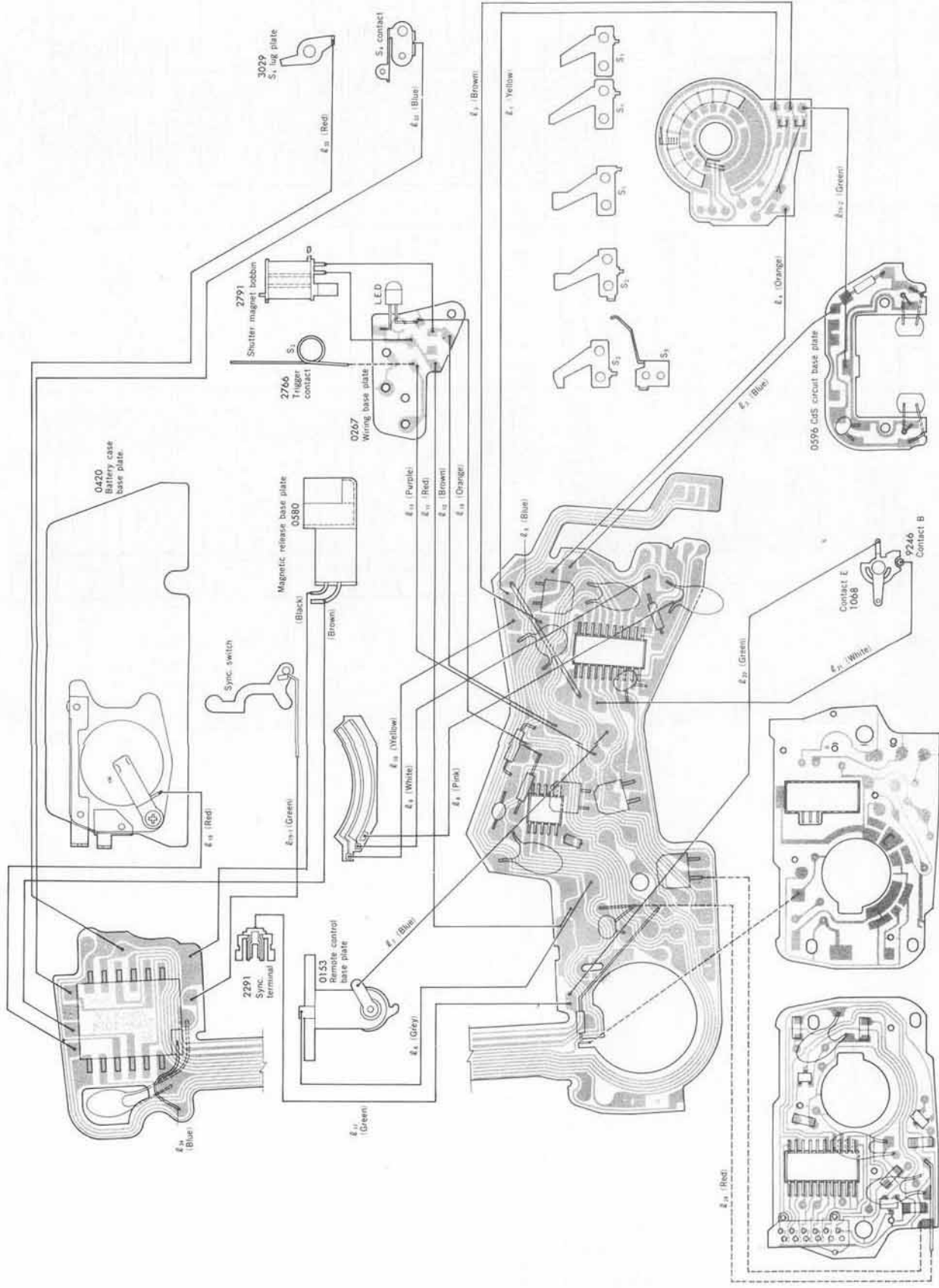

Assy Part No. 2007-0402-03

Assy Part Name Flexible P.C. board set

フレキシブル基板セット

Symbol	Part No.	Com	Part Name	Type.	Qty.	
IC1	2006-4301-03		I C	M51865	1	
IC2	2006-4302-03			M51866	1	
IC3	2006-4303-03			M51867	1	
IC4	2006-4304-07			HIC	1	
D1	9361-5631-01		Diode	KB162	1	
Q3 Q2 Q1	9363-1032-01	02,03	Transistor	2SA1162	3	
R3	9431-1037-31		Fixed resistor	1/16W 10K Ω	1	
R5	9422-1046-32			1/8W 100K Ω	1	
R6	9431-3047-31			1/16W 300K Ω	1	
R7	9422-6806-32			1/8W 68 Ω	1	
R8	9422-3916-32			1/8W 390 Ω	} 1	
	9422-8216-32			1/8W 820 Ω		
	9422-1826-32			1/8W 1.8K Ω		
	9422-3326-32			1/8W 3.3K Ω		
l24	2006-8408-01			Lead wire Pink	ϕ 0.08/7wires $l=35$ mm	1
R9	9422-3016-62			Fixed resistor	1/8W 300 Ω	1
R25 R10	9422-2416-62		1/8W 240 Ω		2	
R23 R21	9422-3036-62		1/8W 30K Ω		2	
R24 R22	9422-1036-62		1/8W 10K Ω		2	
VR1	9472-2049-38		Variable resistor	VG062K 200K Ω	1	
VR3 VR2	9472-1539-38			VG062K 15K Ω	2	
VR4	9472-1529-38			VG062K 1.5K Ω	1	
C1	9535-1555-36		Condenser	1.5 μ F/35V	1	
C2	9535-6845-31			0.68 μ F/35V	1	
C3	9563-4738-31			0.047 μ F/12V	1	
C4	9531-2265-31			22 μ F/3.15V	1	
C5	9531-4765-31			47 μ F/3.5V	1	
C6	9531-1575-61			150 μ F/3.15V	1	
C7	9534-1555-33	or		1.5 μ F/25V	} 1	
	9534-1555-63	or		1.5 μ F/20V		
	9535-1555-31			1/5 μ F/35V		
C8	9531-3365-61			33 μ F/3.15V	1	
l 5	2006-8403-01		Blue	ϕ 0.08/7wires $l=27$ mm	1	
l 28	2006-8411-01		Lead wires Red	ϕ 0.08/7wires $l=45$ mm	1	
l 34	2006-8403-01		Blue	ϕ 0.08/7wires $l=20$ mm	1	

 The R4 is excluded on the Flexible P.C. board set

 R4は0402 (フレキセット) には含まれません

R4	9422-2036-39	Fixed resistor (for adjustment)	1/8W 20K Ω	} 1
	9422-2236-39		1/8W 22K Ω	
	9422-2436-39		1/8W 24K Ω	
	9422-2736-39		1/8W 27K Ω	
	9422-3036-39		1/8W 30K Ω	
	9422-3336-39		1/8W 33K Ω	
	9422-3936-39		1/8W 39K Ω	
	9422-4736-39		1/8W 47K Ω	
	9422-5636-39		1/8W 56K Ω	
	9422-6836-39		1/8W 68K Ω	
	9422-1046-39		1/8W 100K Ω	
	9422-2046-39		1/8W 200K Ω	

Lead wires list

Symbol	Part No.	Color	Typ.	Qty.
l 1	2006-8401-01	Yellow	ø0.08/7 wires l=70	1
l 2	2006-8402-01	Brown	ø0.08/7 wires l=70	1
l 3	2006-8403-01	Blue	ø0.08/7 wires l=45	1
l 4	2006-8404-01	Orange	ø0.08/7 wires l=40	1
l 5	2006-8403-01	Blue	ø0.08/7 wires l=27	1
l 6	2006-8406-01	Grey	ø0.08/7 wires l=110	1
l 7	2006-8403-01	Blue	ø0.08/7 wires l=118	1
l 8	2006-8408-01	Pink	ø0.08/7 wires l=75	1
l 9	2006-8409-01	White	ø0.08/7 wires l=85	1
l 10	2006-8401-01	Yellow	ø0.08/7 wires l=95	1
l 11	2006-8411-01	Red	ø0.08/7 wires l=110	1
l 12	2006-8402-01	Brown	ø0.08/7 wires l=100	1
l 13	2006-8413-01	Purple	ø0.08/7 wires l=100	1
l 16	2006-8404-01	Orange	ø0.08/7 wires l=115	1
l 17	2006-8417-01	Green	ø0.08/7 wires l=144	1
l 18	2006-8411-01	Red	ø0.08/7 wires l=60	1
l 19-2 l 19-1	2006-8417-01	Green	ø0.08/7 wires l=65	2
l 21	2006-8409-01	White	ø0.08/7 wires l=65	1
l 22	2006-8417-01	Green	ø0.08/7 wires l=80	1
l 28	2006-8411-01	Red	ø0.08/7 wires l=45	1
l 32	2006-8411-01	Red	ø0.08/7 wires l=150	1
l 33	2006-8403-01	Blue	ø0.08/7 wires l=150	1
l 34	2006-8403-01	Blue	ø0.08/7 wires l=20	1

■ XG-1(m) CIRCUIT DIAGRAM (2007-300)

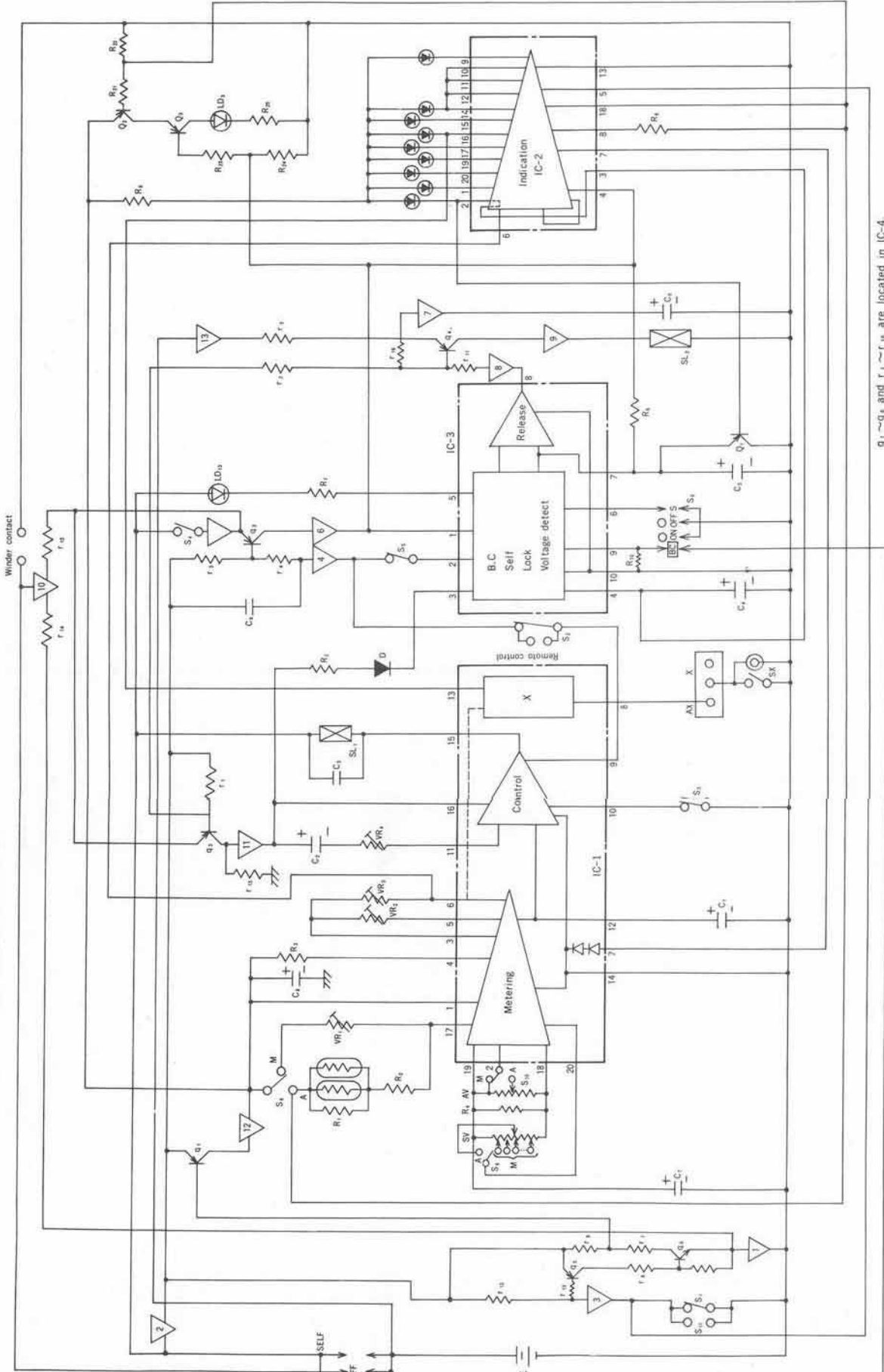

q₁ ~ q₆ and r₁ ~ r₁₀ are located in IC-4.
 q₁ ~ q₆, r₁ ~ r₁₀ は IC-4 内です。

■ Measuring instruments

- Standard luminance box (Model L-2101, *L-223)
- EE tester (Model EE-2101, EE-2111)
- SS adaptor for EE tester (Model SD-2101)
- Shutter tester (Model S-2101, *FS-1DMN4)
- Time counter (Model TC-1)
- Digital multimeter (Model 2508, *3476, *2507)
- Camera standard tester (Model ST-5101)
- Constant voltage DC power supply (Model 524B, *E-1, *E-2)
- Mirror angle adjuster (Model MA-Ⅲ, *Ⅱ)
- Rp resistance selector (Model RS-Ⅳ, *Ⅲ, *Ⅱ, *Ⅰ)
- 1000 mm collimator (Model RC-1000 Ⅲ, *Ⅱ, *Ⅰ)

(Items marked "*" have been discontinued)

■ Exclusive tools

■ Tool No. 2007-3310-75

Top cover pressure nut spanner

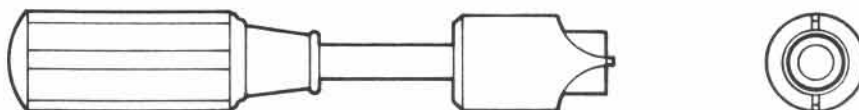

- This is also available for the winding lever pressure (2006-3003) of XG series camera.

■ Tools used in common

- | | | |
|---|---|------------------------------|
| ■ Tool No. 2006-0101-75
Temporary body | ■ Tool No. 2006-3003-75
Winding lever pressure | ■ Flat plate (for 2005) |
| ■ Tool No. 2006-0415-75
Battery adapter | ■ Tool No. 2006-3013-75
Top cover set nut B spanner | ■ Body back gauge (43.70 mm) |
| ■ Tool No. 2006-2020-75
Shutter button pressure spanner | ■ Tool No. 2006-3309-75
Temporary nut | ■ Dial gauge |
| ■ Tool No. 2006-2291-75
Sync. terminal spanner | ■ Tool No. 054-5202-79
Master lens for 054 finder back adjustment | |

■ Sub materials

■ Grease

- #3340
- #335
- #1150D
- LOSIMOL ELT-BAE

■ Oil

- #012

■ Adhesives

- BOND G 17
- 3-BOND 1401B
(for screw lock)
- LOCTITE #242
- SILICON BOND KE-441RTV

■ Cleaner

- FLONSOLVE

MINOLTA XG-A

2013-300 (For Export)

TYPE OF CAMERA

35 mm single-lens reflex with automatic aperture-priority exposure control

SHUTTER

Horizontal-traverse focal-plane type, electronically controlled speeds.

Shutter speed : 1/1000 to 1 sec., steplessly on automatic mode B (bulb), X (1/60)

Shutter dial : Click-stops and lock at "AUTO" (zero setting)
Up to ± 2 Ev continuous adjustment of automatic exposure with 1/2 Ev.

Self-timer : Electronic, LED indicated types; approximately 10 sec. delay

Flash sync : Hot shoe for X sync; Electronic flash synchronizes at 1/60 sec.
Extra contact on hot shoe receives signal from camera-control contact of the X-series Auto Electroflashes

FILM ADVANCE

Film winding : By lever with single 130° stroke after 30° unengaged movement
Film-advance release button for rewinding, advancing-type frame counter and Safe Load Signal that indicates film loading and advancing conditions

Auto winding : Through built-in coupler key with accessory Auto Winder G

Spool : 4-slot take-up spool.

Film counter : Auto resetting calculation.

VIEWFINDER

Type : Eye-level fixed pentaprism type

Viewfinder vision : 93% (standard 24 mm \times 36 mm imagefield).

Magnification : 0.87 \times (50 mm standard lens at ∞)

Visibility : -1 diopt

Viewfinder indication : Acute Matte focusing screen with central horizontally oriented split-image focusing spot surrounded by microprism band, stepless speeds indicated by 7 light-emitting diodes; LED over-/under-range indicators; LED at "60" position also blinks as flash-ready signal with the X-series Auto Electroflashes.

Mirror : Oversize quick-return type

EXPOSURE CONTROL

Light-Metering system : Full-aperture TTL center-weighted averaging type.

Receiver element : By two CdS cells mounted on either side of the eyepiece at the rear of the pentaprism



Auto-exposure control : Special low-voltage, low-current computer circuit, actuated by contact or pressure on "touch switch" operating button, varies the shutter speed continuously and steplessly to yield proper exposure according to metering system indication at the aperture, film speed, and exposure adjustment set.

Auto-exposure range : Ev 2 to Ev 17 (e.g., 1/2 sec. at f/1.4 to 1/1000 at f/11) at ASA 100 with f/1.4 lens

Film-speed range : ASA 25 to 1600 set on the shutter-function selector

Power : Two 1.5V alkaline-manganese (Eveready A-76 or equivalent) or 1.55V silver-oxide (Eveready EPX-76/S-76 or equivalent) cells contained in camera base power both auto exposure control and shutter's electronically governed operation. LED battery check-indicator lights when operating switch in battery check position
Shutter will not release when voltage too low for proper operation

ACCESSORIES

- Exclusive Auto Winder G
- Auto Electroflash 320X, 200X, 132X and 118X
- Wireless Controller IR-1
- Remote Cord S 50 cm (20-in.) and Remote Cord L 5 m (16-ft.).
- MD, MC and other interchangeable Minolta lenses and applicable Minolta SLR system accessories

SIZE AND WEIGHT

Size : 52 (D) \times 88 (H) \times 138 (W) mm
(2 \times 3-7/16 \times 5-5/8 in.)

Weight : 485 g (17-1/8 oz.)
without lens and power cells

I N D E X

Part No.	Page	Part No.	Page	Part No.	Page
2006-0120-----	6	2006-0271-----	16	※2013-0403-----	19
2006-0140-----	4	2013-0272-----	16	2006-0415-----	1
2006-0151-----	9	2006-0273-----	16	2006-0416-----	1
2006-0152-----	9	2006-0274-----	16	2006-0420-----	5
2006-0153-----	9	2007-0277-----	16	2006-0440-----	1
※2013-0160-----	2	2006-0281-----	1		
※2013-0170-----	2	2013-0291-----	1	2006-0503-----	11
※2013-0173-----	6	2013-0295-----	1	2009-0505-----	7
※2013-0191-----	4			2009-0510-----	7
		2019-0310-----	14	2006-0521-----	11
2006-0207-----	18	2006-0325-----	13	2006-0522-----	10
2006-0209-----	18	2019-0326-----	14	2006-0523-----	10
2006-0211-----	18	2006-0338-----	13	2019-0524-----	10
2006-0215-----	17	2019-0340-----	14	2006-0527-----	9
2006-0218-----	17	2006-0350-----	14	2009-0531-----	10
2006-0222-----	17	2019-0360-----	14	2009-0532-----	10
2006-0229-----	17	2006-0375-----	1	2009-0542-----	10
2006-0242-----	17	2019-0381-----	12	2006-0558-----	11
2017-0253-----	18	2006-0384-----	12	2006-0561-----	11
2006-0258-----	18	2006-0385-----	12	2006-0562-----	11
2006-0259-----	18	2019-0396-----	1	2019-0580-----	8
2006-0267-----	18			2006-0586-----	6

※:Parts for only 2013-300(XG-A)

※印パーツは2013-300 (XG-A) 専用パーツ

I N D E X

Part No.	Page	Part No.	Page	Part No.	Page
2007-0592-----	7	2006-1054-----	2	2006-2008-----	16
2013-0596-----	3	2005-1061-----	6	2013-2009-----	16
		2005-1062-----	6	2006-2012-----	16
2006-1006-----	9	2005-1063-----	6	2006-2014-----	1
2019-1007-----	1	2006-1064-----	6	2006-2015-----	16
2006-1008-----	9	2007-1074-----	6	2006-2016-----	16
2006-1009-----	1			2006-2017-----	16
2005-1010-----	6	2007-1105-----	15	2013-2018-----	1
2006-1011-----	6	2007-1106-----	4	2019-2020-----	1
2006-1012-----	13, 15	2006-1110-----	15	2006-2022-----	1
2006-1014-----	9	2006-1111-----	15	2019-2023-----	1
2006-1018-----	2	2006-1112-----	15	2006-2035-----	8
2006-1019-----	3	2006-1116-----	4		
2006-1020-----	13, 15	2006-1119-----	4	2006-2104-----	18
2009-1025-----	9			2006-2105-----	18
0031-1027-----	13, 15	2013-1358-----	1	2006-2106-----	18
0031-1034-----	13, 15			2006-2114-----	17
2006-1041-----	15	※ 2013-1410-----	3	2006-2130-----	17
2006-1042-----	15	※ 2013-1411-----	3	2006-2131-----	17
2006-1043-----	15	※ 2013-1412-----	4	2006-2132-----	17
2006-1052-----	2			2006-2143-----	17
2006-1053-----	2	2013-2005-----	1	2006-2144-----	17

53

I N D E X

Part No.	Page	Part No.	Page	Part No.	Page
2006-2147-----	17	2006-2773-----	18	2006-3052-----	13
2006-2148-----	17	2006-2791-----	18	2006-3053-----	13
2006-2183-----	18			2006-3055-----	13
2006-2184-----	18	2006-3003-----	1	2006-3056-----	14
2006-2185-----	18	2006-3004-----	1	2006-3057-----	14
2006-2189-----	18	2006-3009-----	14		
2006-2192-----	18	2005-3010-----	1	2019-3301-----	1
2006-2196-----	18	2006-3010-----	5	2019-3303-----	1
2006-2197-----	18	2006-3012-----	14	※2013-3304-----	15
2006-2214-----	18	2006-3013-----	1	2019-3306-----	1
		2006-3020-----	14	2006-3308-----	15
2006-2707-----	17	2006-3021-----	14	2006-3309-----	15
2006-2708-----	17	2019-3024-----	5	2006-3310-----	1
2006-2718-----	17	2006-3027-----	14	2019-3311-----	1
2006-2723-----	17	2006-3028-----	14	2006-3312-----	15
2006-2726-----	17	2006-3029-----	14		
2006-2749-----	18	2006-3032-----	13	2006-3404-----	12
2006-2757-----	18	2006-3037-----	13	2019-3407-----	12
2006-2758-----	18	2006-3040-----	14	2006-3408-----	12
2006-2762-----	18	2006-3041-----	13	2006-3410-----	12
2006-2766-----	18	2006-3042-----	13	2006-3411-----	12
2006-2768-----	18	2017-3051-----	14	2006-3412-----	12

I N D E X

Part No.	Page	Part No.	Page	Part No.	Page
2006-3414-----	12	2006-5006-----	3	2006-5042-----	10
2006-3415-----	13	2006-5008-----	3	2006-5044-----	10
2019-3416-----	13	2006-5011-----	7	2006-5046-----	10
2006-3421-----	13	2006-5013-----	7	2009-5051-----	10
		2006-5014-----	7	2009-5058-----	10
2013-4016-----	1	2006-5015-----	7	2009-5081-----	11
2006-4017-----	2	2006-5016-----	7		
2019-4022-----	6	2019-5017-----	7	2006-5110-----	11
2006-4025-----	3	2006-5018-----	7	2006-5111-----	11
		2006-5019-----	11	2006-5112-----	11
2006-4216-----	5	2006-5021-----	11	2006-5113-----	11
2006-4253-----	16	2006-5023-----	11	2006-5114-----	11
2006-4254-----	3	2006-5024-----	7	2006-5116-----	11
2006-4255-----	9	2007-5026-----	3	2006-5117-----	11
2013-4256-----	2	2006-5027-----	11	2006-5118-----	11
2006-4260-----	3	2006-5028-----	11	2006-5119-----	11
2005-4270-----	16	2006-5029-----	11	2006-5120-----	11
		2006-5030-----	11		
2006-4301-----	19	2006-5031-----	7	2007-5801-----	3
2006-4302-----	19	2006-5032-----	7	2007-5803-----	7
2006-4303-----	19	2009-5035-----	7	2009-5805-----	7
2006-4304-----	19	2006-5038-----	9	2019-5806-----	11
		2006-5039-----	7		

55

I N D E X

Part No.	Page	Part No.	Page	Part No.	Page
2006-8401-----	20	2006-9111-----	1	9612-1620-01----	17,18
2006-8402-----	20	2006-9113-----	5	9612-1625-07-----	8
2006-8403-----	19,20	2006-9121-----	15	9612-1628-07-----	6,8
2006-8404-----	20	2006-9131-----	3,5	9612-1635-07-----	6
2006-8406-----	20	2006-9132-----	5	9612-1675-07-----	16
2006-8408-----	19,20	2006-9133-----	5	9612-1685-07-----	3
2006-8409-----	20			9613-1418-07-----	12
2006-8411-----	20	2013-9246-----	2	9613-1645-07-----	8
2006-8413-----	20	2006-9401-----	15	9613-1650-01-----	2
2006-8417-----	20	2006-9409-----	15		
				9615-1416-01-----	17
2006-9004-----	8	Screw		9615-1420-01-----	17
2006-9005-----	9	9611-1616-12-----	11	9615-1625-02-----	17
2006-9011-----	14	9611-1620-01-----	18	9622-1630-01-----	7
2006-9012-----	14	9611-1625-07-----	8,9		
		9611-1630-04-----	15	9693-1740-04-----	1
2006-9103-----	9	9611-2032-04-----	6	9693-1750-07-----	1
2006-9105-----	16	9611-2090-07-----	13,15	9695-1740-07-----	3,7
2006-9106-----	11,13				
2006-9107-----	9	9612-1616-07-----	6,9,11	9761-1728-07-----	14
2019-9108-----	14			9761-2040-07-----	13
2006-9110-----	1,5	9612-1618-01-----	18	9761-2050-07-----	15

I N D E X

Part No.	Page	Part No.	Page	Part No.	Page
9761-2055-07-----	12	9794-3858-20-----	11	9422-2046-39-----	19
				9422-2216-32-----	3
9762-1740-07---	5, 7, 15	L.E.D		9422-2236-39-----	19
9762-1745-07-----	3, 12	9353-2642-01-----	18	9422-2416-62-----	19
9762-2040-07-----	14			9422-2436-39-----	19
9762-2050-07-----	14	Diode		9422-2716-32-----	3
		9361-5631-01-----	19	9422-2736-39-----	19
E-ring					
9721-0080-13-----	11	Transistor		9422-3016-62-----	19
9721-0120-13-----	12, 18	9363-1032-01-----	19	9422-3036-39-----	19
9721-0150-13-----	10, 11 17, 18				
9721-0200-13-----	13	Fixed resistor		9422-3316-32-----	3
		9422-1026-32-----	3	9422-3326-32-----	19
Steel ball				9422-3336-39-----	19
9758-0200-00-----	1	9422-1046-32-----	19	9422-3916-32-----	3, 19
		9422-1046-39-----	19	9422-3936-39-----	19
Washer		9422-1226-32-----	3		
9792-2050-40-----	10	9422-1516-32-----	3	9422-4716-32-----	3
9793-1635-40-----	17	9422-1526-32-----	3	9422-4736-39-----	19
9793-1840-86-----	3	9422-1826-32-----	3, 19	9422-5616-32-----	3
9793-2038-50-----	14			9422-5636-39-----	19
9793-2140-40-----	10	9422-2036-39-----	19	9422-6806-32-----	19
9793-2250-40-----	17				

57

I N D E X

Part No.	Page	Part No.	Page
9422-6816-32-----3		Condenser	
9422-6836-39-----19		9531-1575-61-----19	
9422-8216-32-----3, 19		9531-2265-31-----19	
		9531-3365-31-----19	
9431-1037-31-----19		9531-4765-31-----19	
9431-1057-31-----3			
9431-1257-31-----3		9534-1555-33-----19	
9431-1557-31-----3		9534-1555-63-----19	
9431-3047-31-----19		9535-1555-31-----19	
9431-3347-31-----3		9535-1555-36-----19	
9431-3947-31-----3		9535-6845-31-----19	
9431-4747-31-----3		9563-4738-31-----19	
9431-5647-31-----3			
9431-6847-31-----3			
9431-8247-31-----3			
Variable resistor			
9472-1059-38-----19			
9472-1529-38-----19			
9472-1539-38-----19			

XG-A CODE No. 2013-300

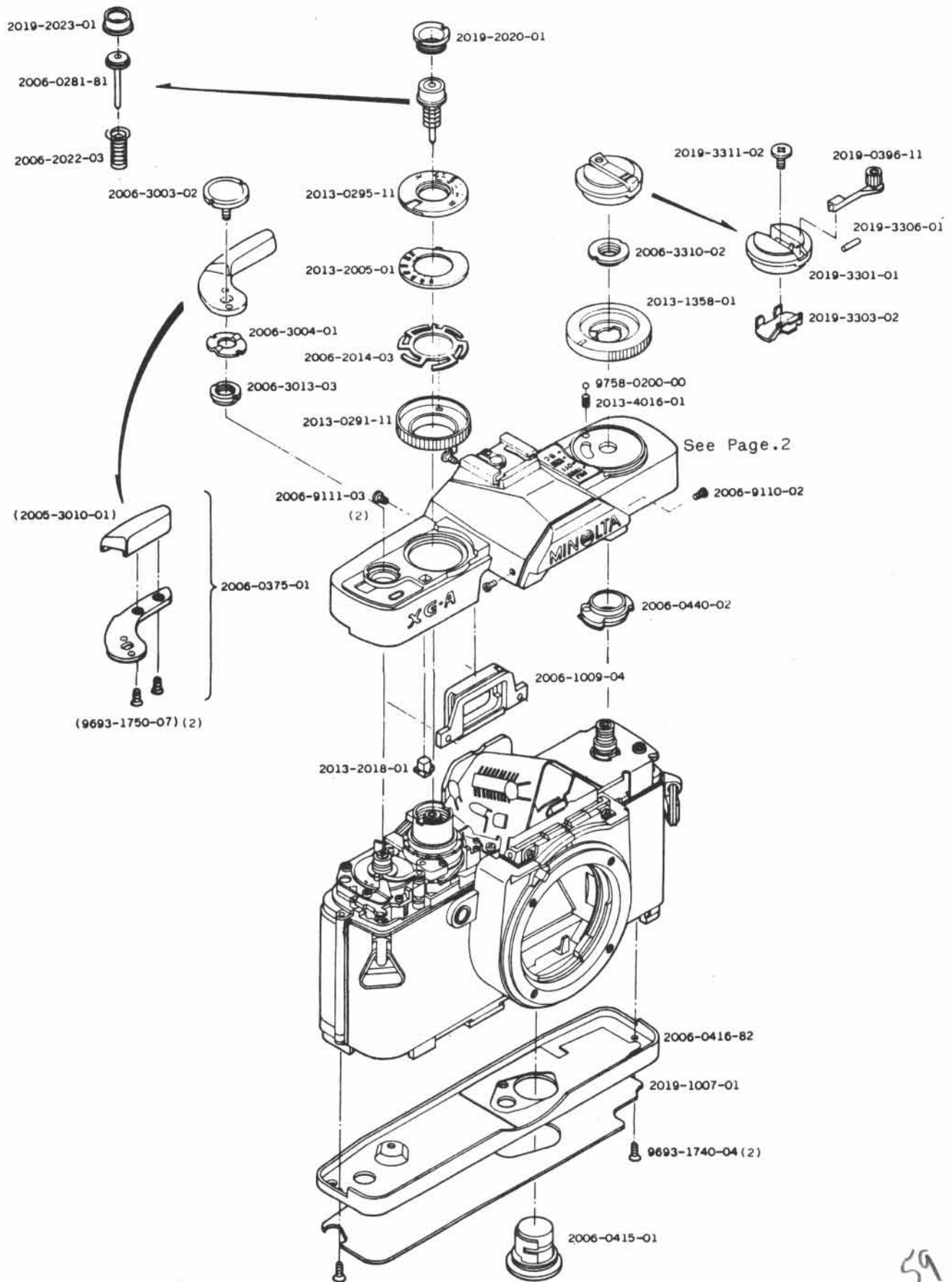

Part No.	Part Name		Qty
2006-0281-81	Shutter release button set	シャッター鉤軸セット	1
2013-0291-11	Shutter speed dial/Function selector	シャッターダイヤルセット	1
2013-0295-11	Shutter speed dial	シャッターダイヤル銘板	1
2006-0375-01	Film advance lever set	巻上レバーセット	1
(2005-3010-01)	Film advance lever knob	巻上レバー指当て	1
(9693-1750-07)	Tap tite screw	十字穴付タッピングねじ	2
2019-0396-11	Rewinding handle set	巻戻しハンドルセット	1
2006-0415-01	Battery holder set	電池ケース蓋	1
2006-0416-82	Bottom cover set	下カバーセット	1
2006-0440-02	Self-timer change holder set	セルフ切換接片ホルザーセット	1
2019-1007-01	Sheet	下カバー保護シート	1
2006-1009-04	Eye-piece lens frame	接眼枠	1
2013-1358-01	Self-timer dial	セルフダイヤル	1
2013-2005-01	ASA dial	ASA 銘板	1
2006-2014-03	ASA spring	ASA スプリング	1
2013-2018-01	Auto lock button	オートロック鉤	1
2019-2020-01	Shutter release button pressure	シャッター鉤押え	1
2006-2022-03	Shutter release button spring	シャッター鉤スプリング	1
2019-2023-01	Shutter release button cap	シャッター鉤キャップ	1
2006-3003-02	Winding lever pressure	巻上レバー押え	1
2006-3004-01	Winding lever friction	巻上レバーフリクション	1
2006-3013-03	Top cover set nut-B	上カバー止めナット	1
2019-3301-01	Rewinding knob	巻戻しノブ	1
2019-3303-02	Rewinding handle spring	巻戻しバネ	1
2019-3306-01	Rewinding handle axis	巻戻しハンドル軸	1
2006-3310-02	Top cover pressure nut	上カバー押えナット	1
2019-3311-02	Rewinding knobscrew	巻戻しノブビス	1
2013-4016-01	Self-timer dial click spring	セルフダイヤルクリックSP	1
2006-9110-02	Screw-A	特殊止めビス	2
2006-9111-03	Screw-B	特殊止めビス	2
9693-1740-04	Phillips type tapping screw	十字穴付タッピングねじ	2
9758-0200-00	Steel ball	スチールボール	1

XG-A CODE No. 2013-300

Assy. Part No. 2013-0170-11

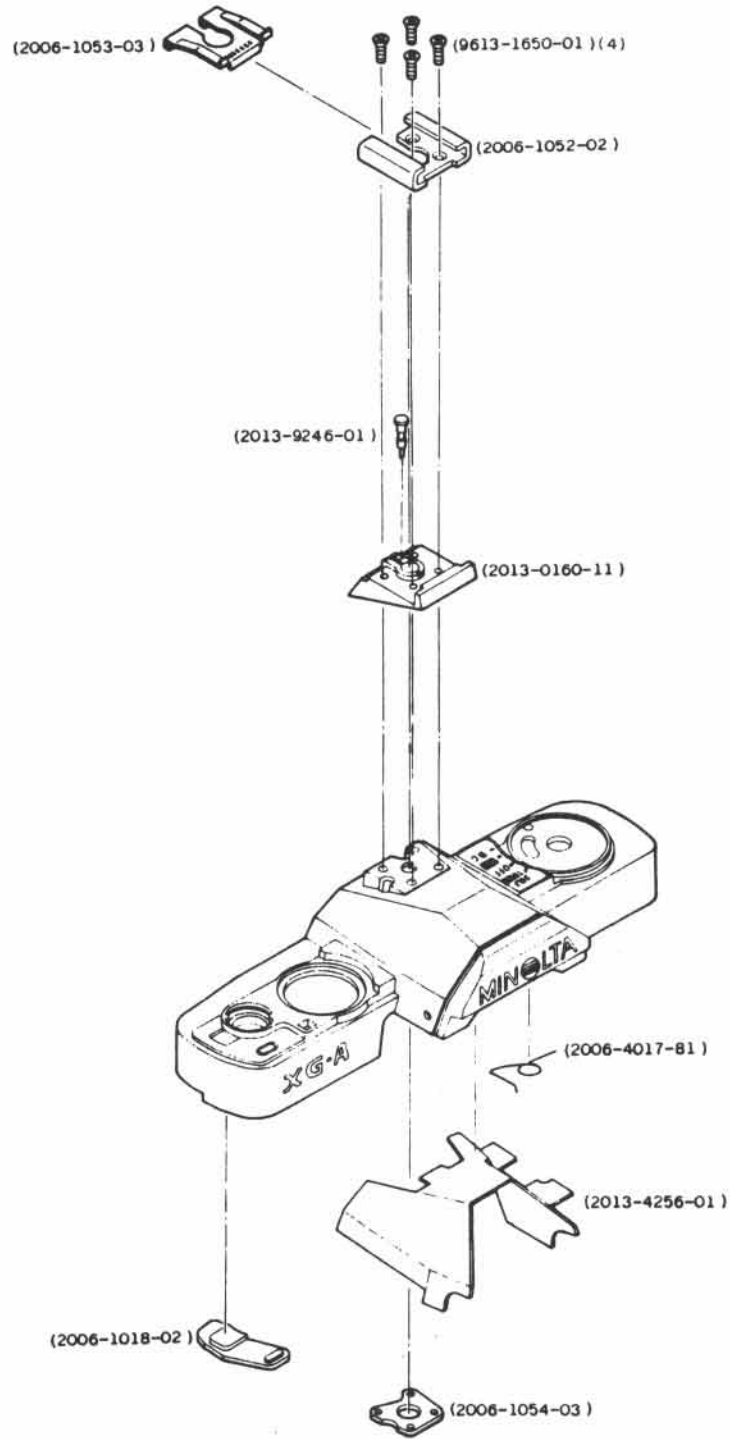

61

Part No.	Part Name		Qty
※ 2013-0170-11	Top cover set	上カバーセット	1
※(2013-0160-11)	Accessory shoe base set	アクセサリーシュー座	1
(2006-1018-02)	Counter window	カウンター窓	1
(2006-1052-02)	Accessory shoe	アクセサリーシュー	1
(2006-1053-03)	Accessory shoe spring	アクセサリーシューパネ	1
(2006-1054-03)	Accessory shoe set plate	アクセサリーシュー取付板	1
(2006-4017-81)	Self-timer return spring-B	セルフダイヤル戻しSP	1
(2013-4256-01)	Top cover isolation sheet	上カバー絶縁シート	1
(2013-9246-01)	Contact-B	コンタクト接片B	1
(9613-1650-01)	Phillips type screw	十字穴付小ねじ	4

※:Parts for only 2013-300(XG-A)

※印は2013-300 (XG-A) 専用部品

XG-A CODE No. 2013-300

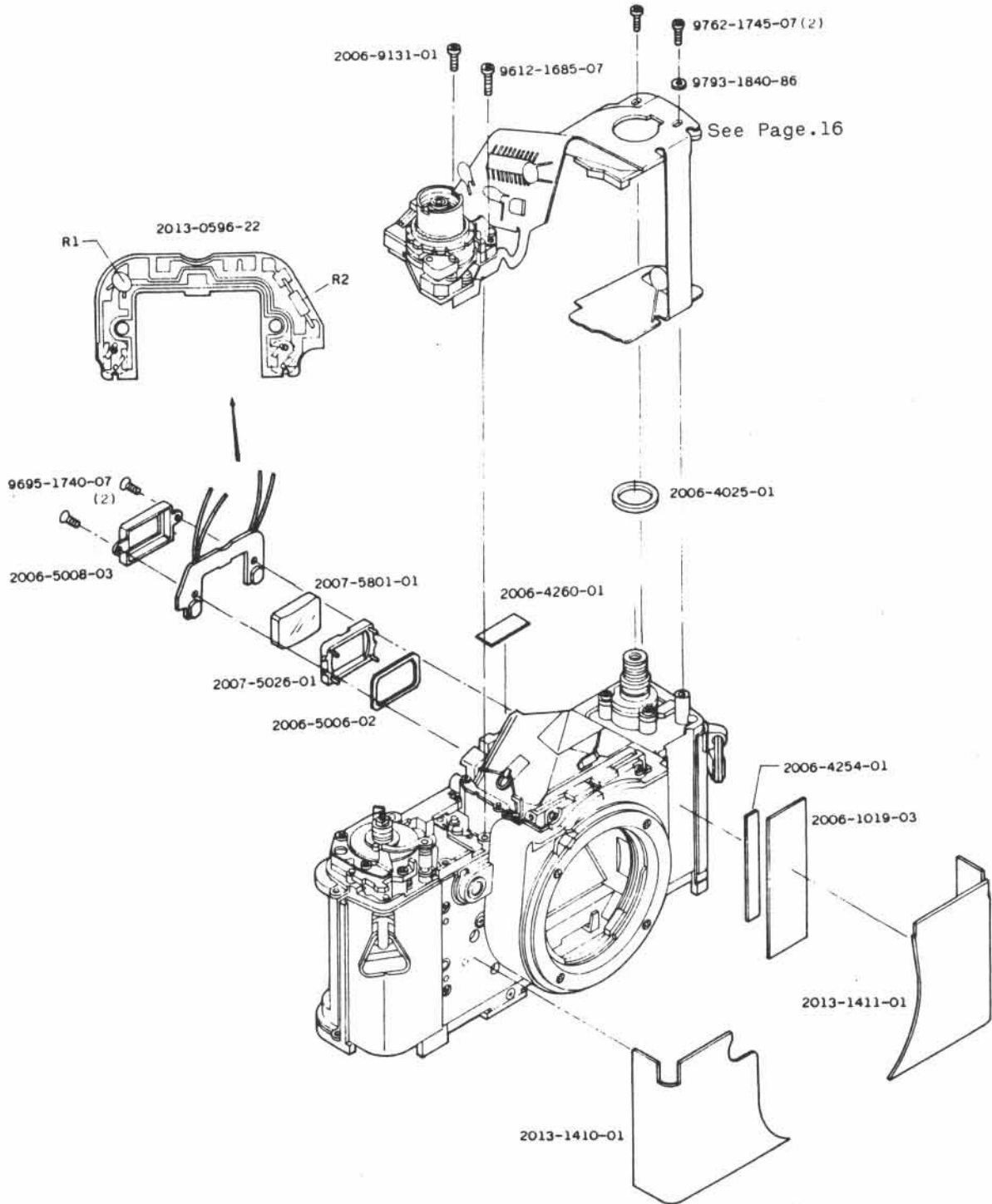

Part No.	Part Name		Qty
2013-0596-22	CdS circuit base plate set	CdS 基板セット	1
2006-1019-03	Body leather	ボデー貼板	1
※2013-1410-01	Right side leather	ボデー貼皮 (右)	1
※2013-1411-01	Left side leather	ボデー貼皮 (左)	1
2006-4025-01	Contact receiver	セルフ切換接片ホルダー受	1
2006-4254-01	Tape-A (5X45mm)	フレキ接着テープ	1
2006-4260-01	Isolation tape-A (4.5X15mm)	絶縁紙	1
2006-5006-02	Eye-piece lens light shield frame	接眼レンズ遮光枠	1
2006-5008-03	Eye-piece lens pressure	接眼レンズ押え	1
2007-5026-01	Eye-piece lens holder	接眼レンズホルダー	1
2007-5801-01	Eye-piece lens	接眼レンズ	1
2006-9131-01	Battery case set screw-A	特殊止めビス	1
9612-1685-07	Phillips type screw	十字穴付小ねじ	1
9695-1740-07	Phillips type screw	十字穴付小ねじ	2
9762-1745-07	Tap tite screw	十字穴付タップタイトねじ	2
9793-1840-86	Washer	薄ワッシャー	1

※:Parts for only 2013-300(XG-A)

※印は2013-300 (XG-A) 専用部品

Symbol	Part No.	Part Name	Type.	Qty.
R1	9431-3347-31	Fixed resistor	1/16W, 330K Ω	1
	9431-3947-31		1/16W, 390K Ω	
	9431-4747-31		1/16W, 470K Ω	
	9431-5647-31		1/16W, 570K Ω	
	9431-6847-31		1/16W, 680K Ω	
	9431-8247-31		1/16W, 820K Ω	
	9431-1057-31		1/16W, 1M Ω	
	9431-1257-31		1/16W, 1.2M Ω	
	9431-1557-31		1/16W, 1.5M Ω	
R2	9422-1516-32	Fixed resistor	1/8W, 150 Ω	1
	9422-2216-32		1/8W, 220 Ω	
	9422-2716-32		1/8W, 270 Ω	
	9422-3316-32		1/8W, 330 Ω	
	9422-3916-32		1/8W, 390 Ω	
	9422-4716-32		1/8W, 470 Ω	
	9422-5616-32		1/8W, 560 Ω	
	9422-6816-32		1/8W, 680 Ω	
	9422-8216-32		1/8W, 820 Ω	
	9422-1026-32		1/8W, 1K Ω	
	9422-1226-32		1/8W, 1.2K Ω	
	9422-1526-32		1/8W, 1.5K Ω	
	9422-1826-32		1/8W, 1.8K Ω	

64

XG-A **CODE No. 2013-300**

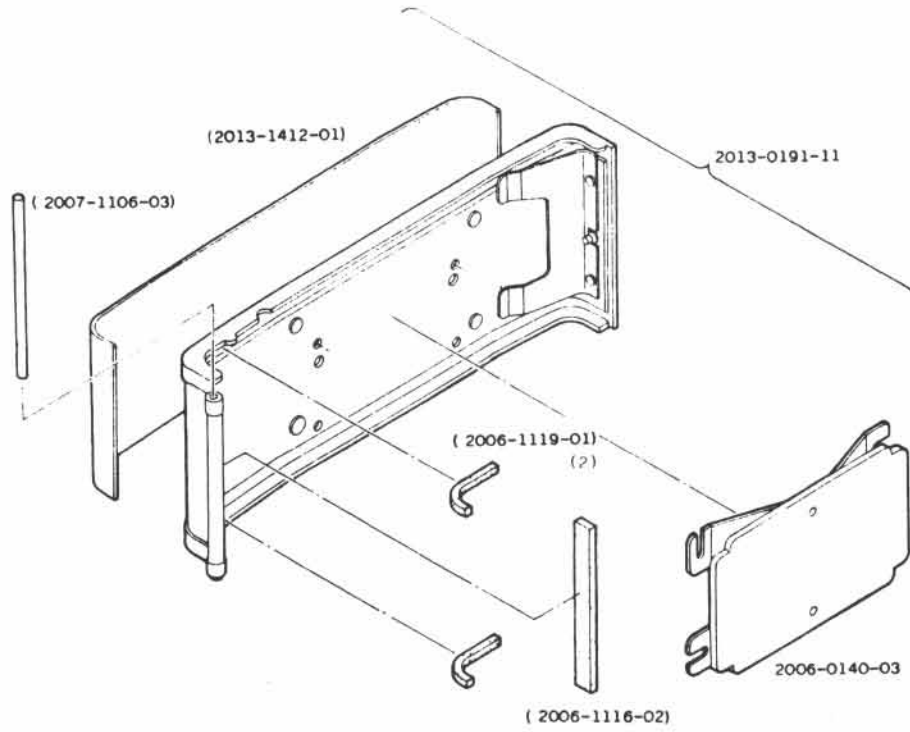

65

Part No.	Part Name		Qty
※2013-0191-11	Back cover set	裏蓋セット	1
(2007-1106-03)	Hinge axis-A	ヒンジ軸 A	1
(2006-1116-02)	Light shield plate	裏蓋遮光片	1
(2006-1119-01)	Light shield plate-B	裏蓋遮光片-B	2
※(2013-1412-01)	Back cover leather	裏蓋貼皮	1
2006-0140-03	Pressure plate set	圧着板セット	1

※:Parts for only 2013-300(XG-A)

※印は2013-300 (XG-A) 専用部品

XG-A **CODE No. 2013-300**

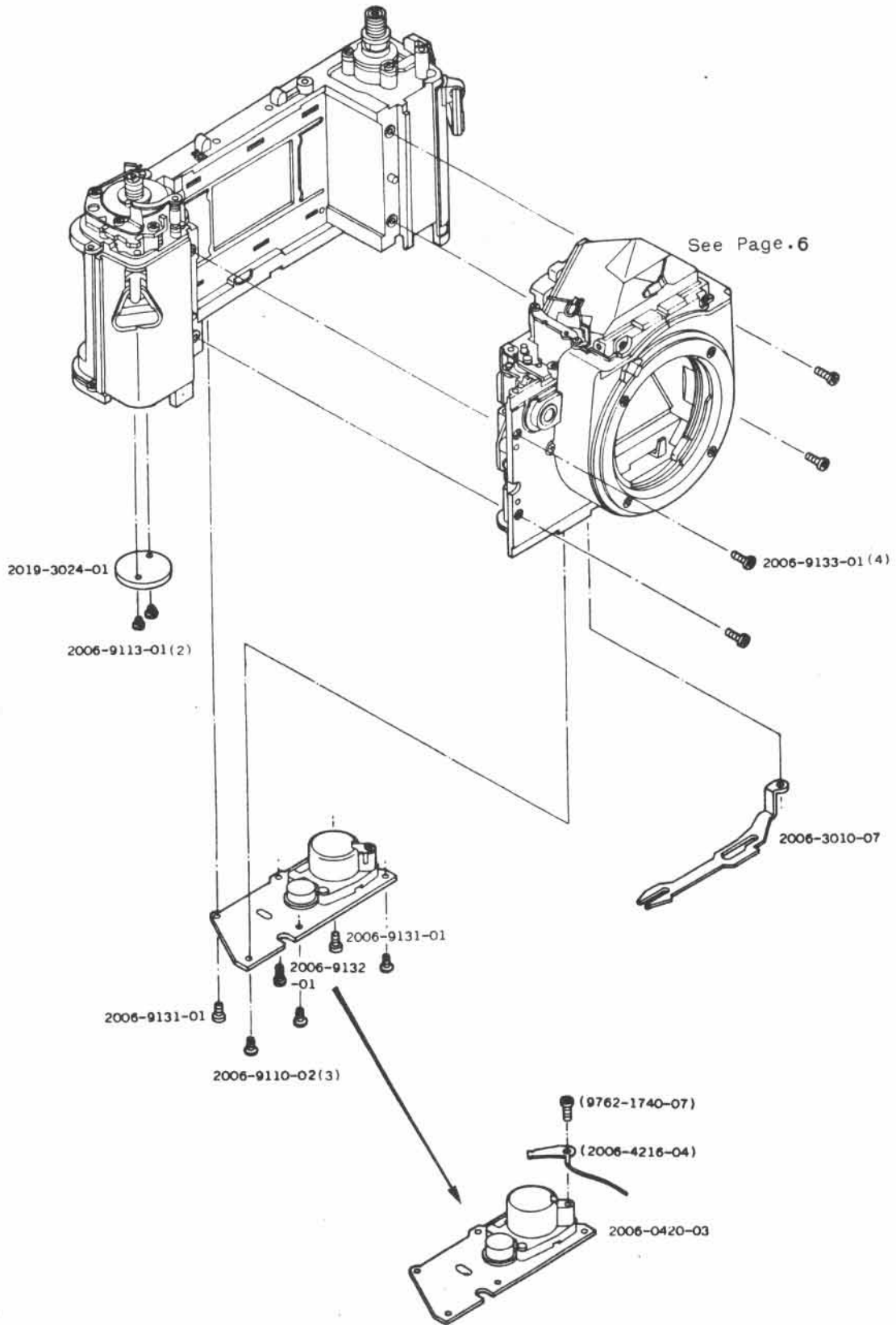

67

Part No.	Part Name		Qty
2006-0420-03	Battery case base plate set	電池ケース台板	1
(2006-4216-04)	Plus side contact	電池ケース接片 (+)	1
(9762-1740-07)	Tap tite screw	十字穴付なべ頭タップタイトねじ	1
2006-3010-07	Charge lever	チャージレバー	1
2019-3024-01	Winder coupler	ワインダーカプラー	1
2006-9110-02	Screw-A	止めビス	3
2006-9113-01	Screw	止めビス	2
2006-9131-01	Battery case set screw-A	止めビス	2
2006-9132-01	Battery case set screw-B	止めビス	1
2006-9133-01	Front base plate set screw	止めビス	4

XG-A CODE No. 2013-300

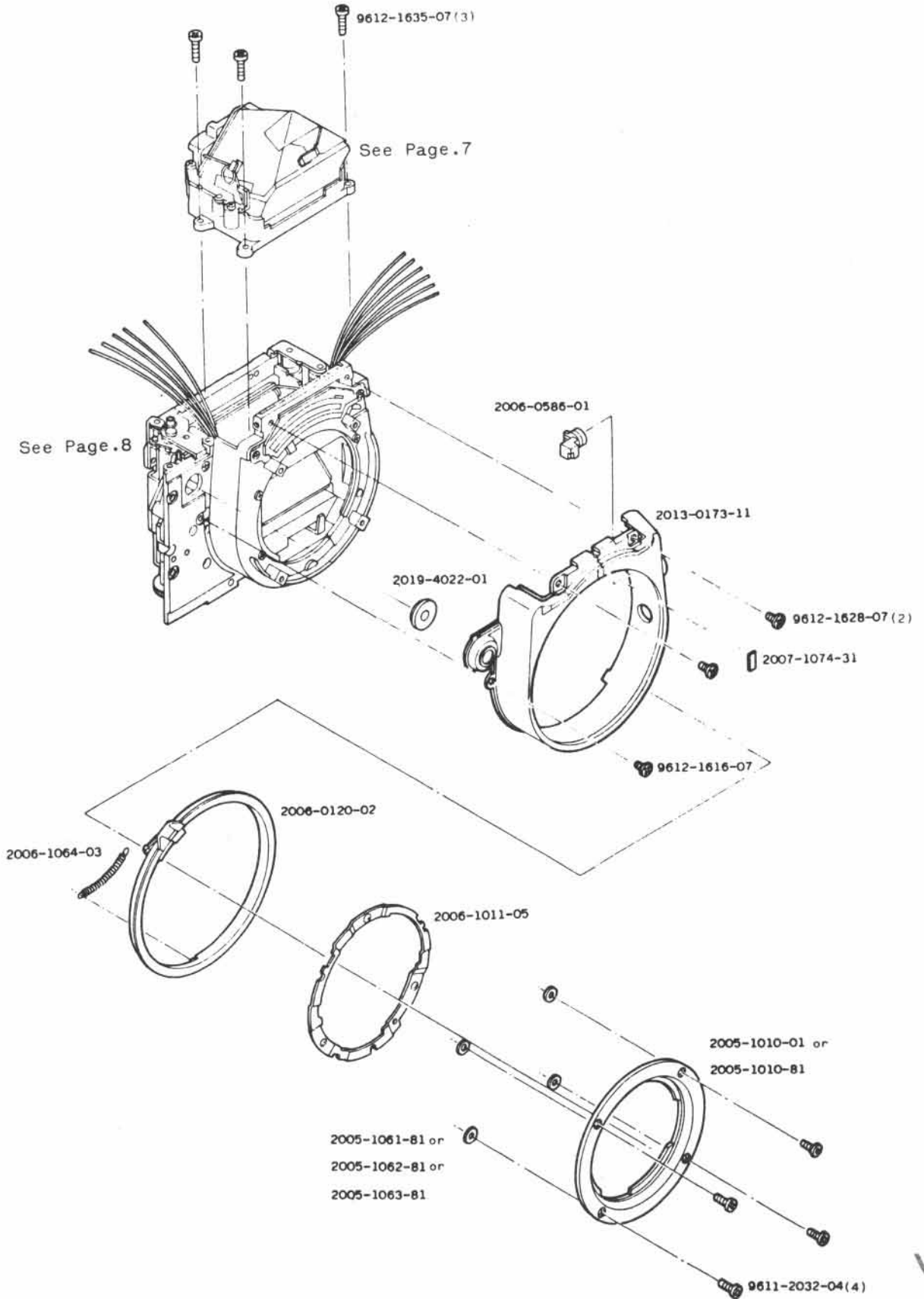

Part No.	Part Name		Qty
2006-0120-02	Aperture coupling ring set	連絡リングセット	1
※ 2013-0173-11	Front cover set	前カバーセット	1
2006-0586-01	Lens lock button set	レンズロック釦セット	1
2005-1010-01	Bayonet lens mount	バヨネット座板	} 1
2005-1010-81	Bayonet lens mount (-0.1mm)	バヨネット座板 (-0.1mm)	
2006-1011-05	Bayonet spring	バヨネットスプリング	1
2005-1061-81	Adjustment washer-A t=0.02	調整ワッシャー-A	} Some
2005-1062-81	Adjustment washer-B t=0.05	調整ワッシャー-B	
2005-1063-81	Adjustment washer-C t=0.1	調整ワッシャー-C	
2006-1064-03	Aperture coupling ring spring	連結リングスプリング	1
2007-1074-31	Front cover indication	前カバー指標	1
2019-4022-01	Reflection ring	セルフ表示反射環	1
9611-2032-04	Phillips type screw	十字穴付小ねじ	4
9612-1616-07	Phillips type screw	十字穴付小ねじ	1
9612-1628-07	Phillips type screw	十字穴付小ねじ	2
9612-1635-07	Phillips type screw	十字穴付小ねじ	3

※:Parts for only 2013-300(XG-A)

※印は2013-300 (XG-A) 専用部品

XG-A CODE No. 2013-300

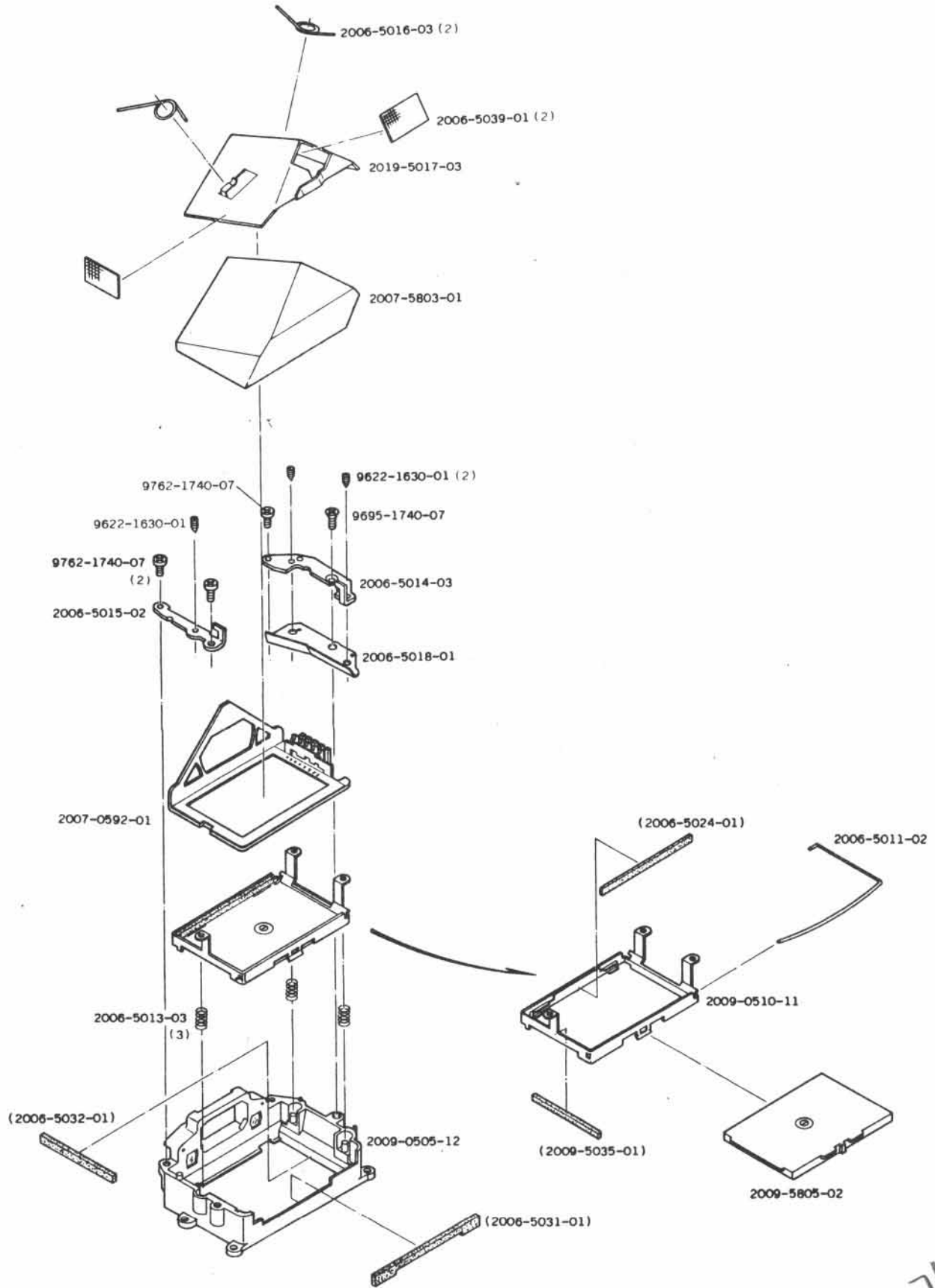

71

Part No.	Part Name		Qty
2009-0505-12	Penta. holder set	ペンターホルダーセット	1
(2006-5031-01)	Packing-A	防塵モルトブレンA	1
(2006-5032-01)	Packing-B	防塵モルトブレンB	1
2009-0510-11	Fresnel lens holder set	焦点板ホルダーセット	1
(2006-5024-01)	Packing-C	防塵モルトブレンC	1
(2009-5035-01)	Shield plate	防塵塩ビシート	1
2007-0592-01	Penta. reciver set	ペンタ受セット	1
2006-5011-02	Fresnel lens pressure spring	焦点板押えSP	1
2006-5013-03	Fresnel lens holder spring	焦点板ホルダーSP	3
2006-5014-03	Penta. pressure (Left side)	ペンタ押え (左)	1
2006-5015-02	Penta. pressure (Right side)	ペンタ押え (右)	1
2006-5016-03	Penta. spring	ペンタ押えSP	2
2019-5017-03	Penta. pressuré	ペンタ押え板	1
2006-5018-01	LED diffusion plate	LED 拡散板	1
2006-5039-01	Penta. pressure tape per meter	ペンタ押え板接着テープ	2
2007-5803-01	Penta. prism	ペンタプリズム	1
2009-5805-02	Fresnel lens	焦点板	1
9622-1630-01	Screw	トガリ先止めねじ	3
9762-1740-07	Tap tite screw	十字穴付なべ頭タップタイトねじ	3
9695-1740-07	Phillips type tapping screw	十字穴付皿頭タッピングねじ	1

XG-A CODE No. 2013-300

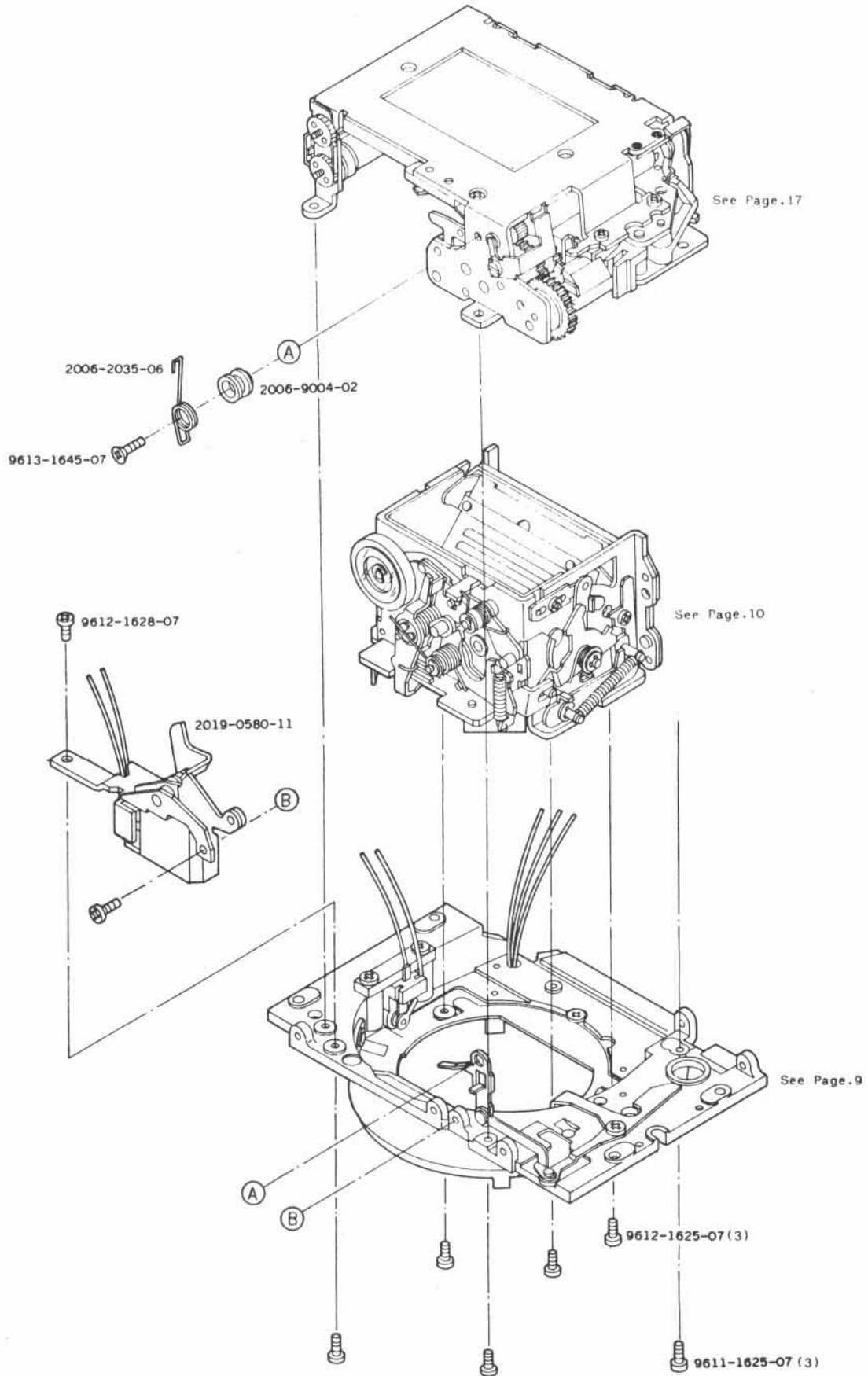

13

Part No.	Part Name		Qty
2019-0580-11	Magnetic release base plate set	レリーズマグネット台板	1
2006-2035-06	Release operation lever spring	吸着用SP	1
2006-9004-02	Release operation lever A setscrew	レリーズ連結レバーA軸	1
9611-1625-07	Phillips type screw	十字穴付なべ頭小ねじ	3
9612-1625-07	Phillips type screw	十字穴付なべ頭小ねじ	3
9612-1628-07	Phillips type screw	十字穴付なべ頭小ねじ	2
9613-1645-07	Phillips type screw	十字穴付半丸皿頭小ねじ	1

XG-A CODE No. 2013-300

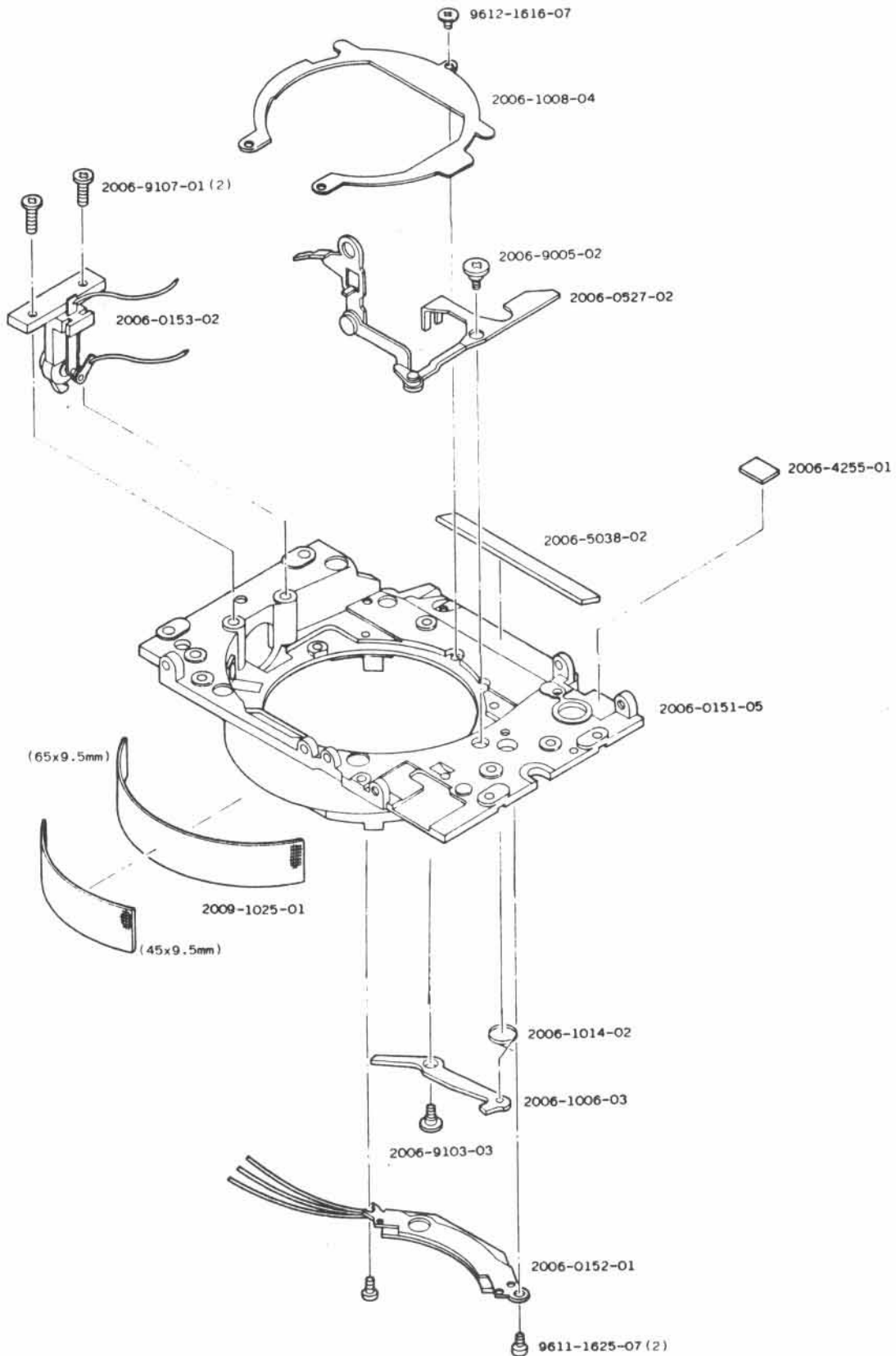

75

Part No.	Part Name		Qty
2006-0151-05	Front base plate set	前枠セット	1
2006-0152-01	Av resitor set	回路基板Bセット	1
2006-0153-02	Remote control base plate set	リモコン接片基板セット	1
2006-0527-02	Release operation lever-A set	レリーズ連結レバーセット	1
2006-1006-03	Lens lock lever	レンズロックレバー	1
2006-1008-04	Mirror box light shield plate	ミラーボックス遮光板	1
2006-1014-02	Lock lever spring	ロックレバーSP	1
2009-1025-01	Scotch tape	前カバーガタ防止用テープ	1
2006-4255-01	Tape A (3.8X8)	テープ A	1
2006-5038-02	Pneta. front packing	ペンタ前面押えクッション	1
2006-9005-02	Release operation lever-C setscrew	止めねじ	1
2006-9103-03	Lens lock axis	レンズロック軸	1
2006-9107-01	Screw-D	止めねじ	2
9612-1616-07	Phillips type screw	十字穴付なべ頭小ねじ	1
9611-1625-07	Phillips type screw	十字穴付なべ頭小ねじ	2

XG-A **CODE No. 2013-300**

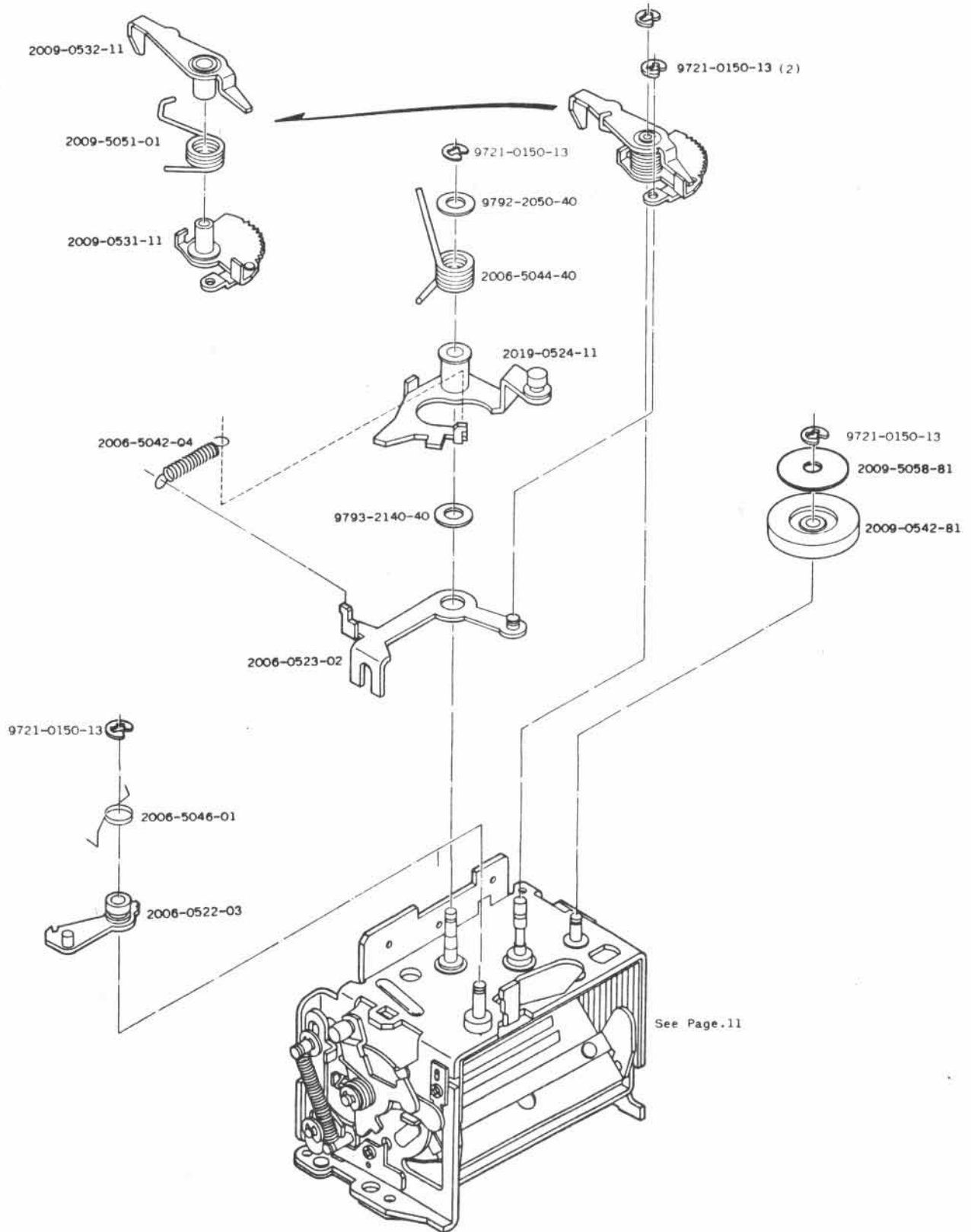

77

Part No.	Part Name		Qty
2006-0522-03	Mirror return lever lock claw set	ミラー戻しレバーロック爪	1
2006-0523-02	Preset operation lever set	ブリセット連動レバーセット	1
2019-0524-11	Mirror return lever set	ミラー戻しレバーセット	1
2009-0531-11	Preset operation plate set	ブリセット作動板	1
2009-0532-11	Preset lever set	ブリセットレバー	1
2009-0542-81	Fly wheel gear set	フライホールギヤー	1
2006-5042-04	Mirror-up spring	ミラーアップSP	1
2006-5044-04	Mirror return spring	ミラー戻しSP	1
2006-5046-01	Lock claw spring	ロック爪スプリング	1
2009-5051-01	Preset lever spring	ブリセットレバーSP	1
2009-5058-81	Fly wheel washer	フライホイールワッシャー	1
9721-0150-13	E-ring	Eリング	5
9792-2050-40	Washer	薄ワッシャー	1
9793-2140-40	Washer	薄ワッシャー	1

XG-A CODE No. 2013-300

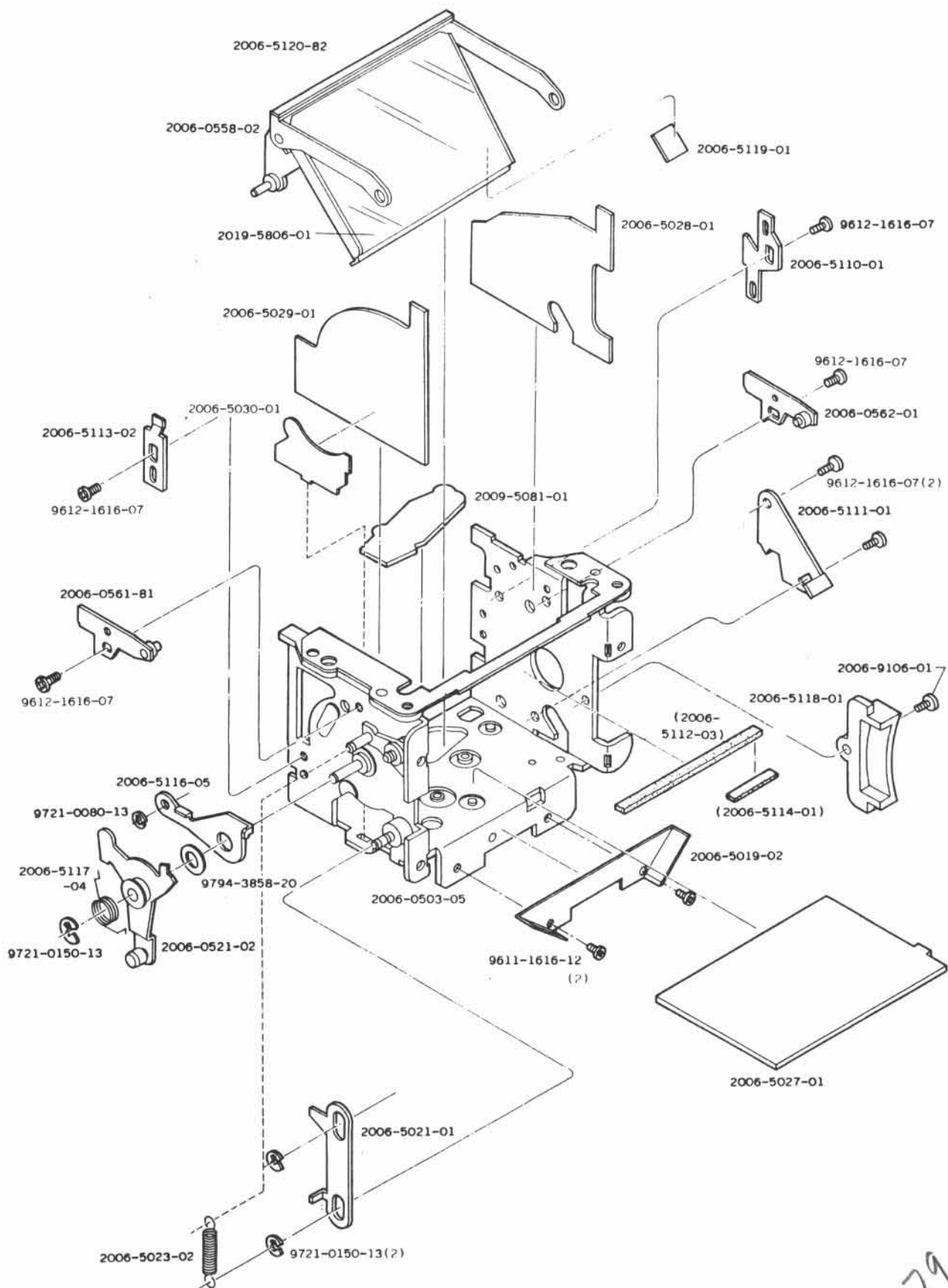

79

Part No.	Part Name		Qty
2006-0503-05	Mirror box set	ミラーボックスセット	1
(2006-5112-03)	Mirror cushion	ミラークッション	1
(2006-5114-01)	Mirror cushion-B	ミラークッションB	1
2006-0521-02	Mirror operation lever-set	ミラー操作レバーセット	1
2006-0558-02	Mirror holder set	ミラーホルダーセット	1
2006-0561-81	Operation lever-B base set (Right)	ミラー操作レバーB軸台セット (右)	1
2006-0562-01	Operation lever-B base set (Left)	ミラー操作レバーB軸台セット (左)	1
2006-5019-02	Mirror box apron	ミラーボックスエプロン	1
2006-5021-01	Mirror release lever	ミラーリリースレバー	1
2006-5023-02	Release lever spring	ミラーリリースレバーSP	1
2006-5027-01	Flare shield plate(bottom)	フレア防止シート(下)	1
2006-5028-01	Flare shield plate(Left side)	フレア防止シート(左)	1
2006-5029-01	Flare shield plate(Right side)	フレア防止シート(右)	1
2006-5030-01	Flare shield support plate	フレア防止シート補助板	1
2009-5081-01	Mirror box cover	ミラーボックス穴カバー	1
2006-5110-01	Mirror support stopper-A	ミラー補助ストッパーA	1
2006-5111-01	Mirror stopper	ミラーストッパー	1
2006-5113-02	Mirror support stopper-B	ミラー補助ストッパーB	1
2006-5116-05	Mirror operation lever-B	ミラー作動レバー	1
2006-5117-04	Mirror operation lever spring	ミラー操作レバーSP	1
2006-5118-01	Mirror box light shield plate	ミラーボックス遮光片	1
2006-5119-01	Mirror stopper gum	ミラーストッパーゴム	1
2006-5120-82	Mirror arm cushion	ミラーアームクッション	1
2019-5806-01	Mirror	ミラー	1
2006-9106-01	Screw-C	止めビス	1
9611-1616-12	Phillips type screw	十字穴付なべ頭小ねじ	2
9612-1616-07	Phillips type screw	十字穴付なべ頭小ねじ	6
9721-0080-13	E-ring	Eリング	1
9721-0150-13	E-ring	Eリング	3
9794-3858-20	Washer	薄ワッシャー	1

80

XG-A **CODE No. 2013-300**

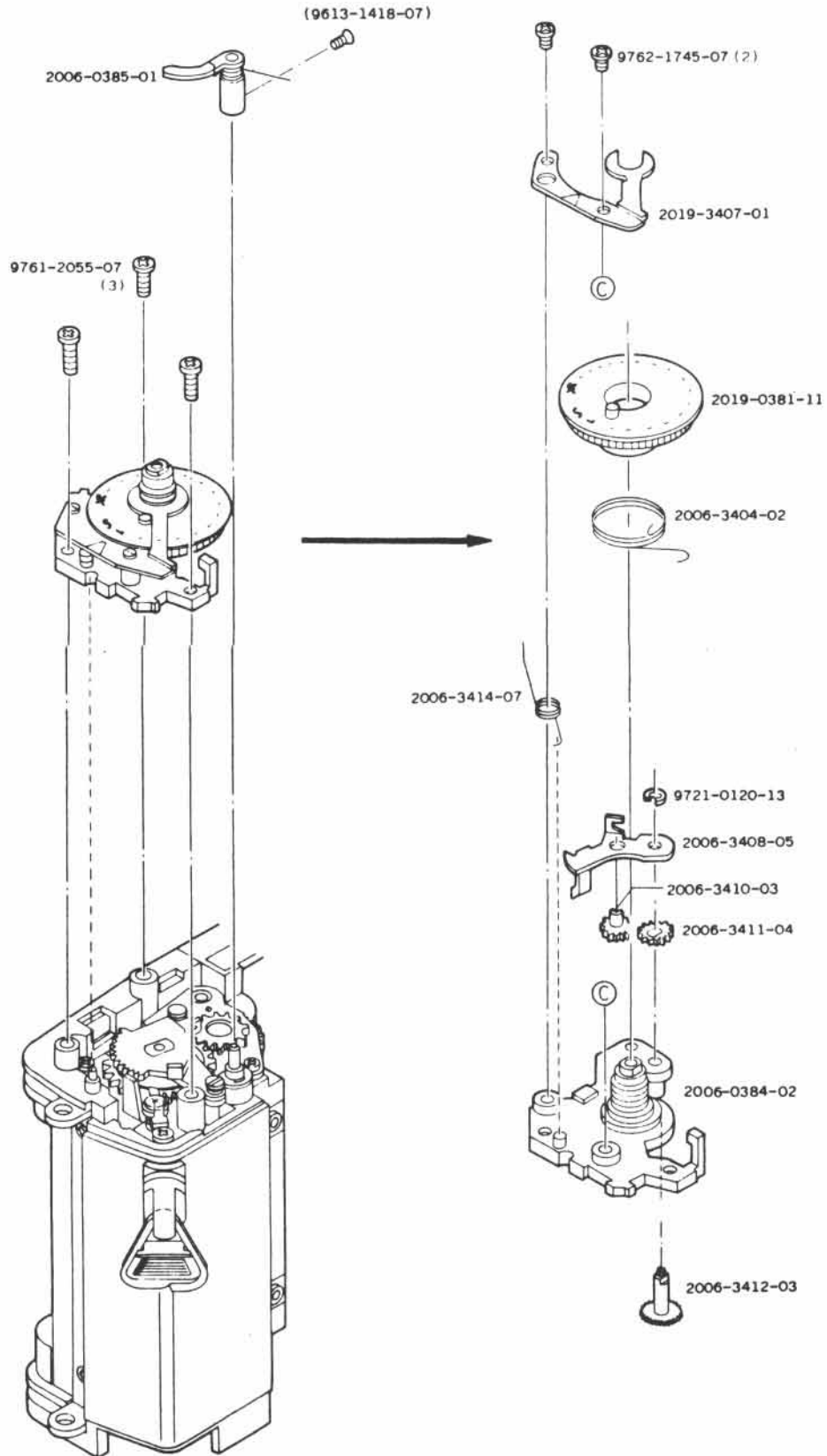

81

Part No.	Part Name		Qty
2019-0381-11	Counter dial set	カウンターダイヤルセット	1
2006-0384-02	Winding base palte-B set	巻取台板Bセット	1
2006-0385-01	Film indication lever axis set	フィルム表示レバーセット	1
(9613-1418-07)	Phillips type screw	十字穴付半丸皿頭小ねじ	1
2006-3404-02	Counter return spring	カウンター戻しSP	1
2019-3407-01	Counter index	カウンター指標	1
2006-3408-05	Counter operation lever	カウンター駆動操作レバー	1
2006-3410-03	Counter operation gear-B set	カウンター駆動ギヤー	1
2006-3411-04	Counter operation gear-C set	カウンター伝達ギヤー	1
2006-3412-03	Counter operation gear-A	カウンター連結ギヤー	1
2006-3414-07	Return lever spring	ゼロリターンSP	1
9761-2055-07	Tap tite screw	十字穴付なべ頭タップタイトねじ3	
9762-1745-07	Tap tite screw	十字穴付なべ頭タップタイトねじ2	
9721-0120-13	E-ring	Eリング	1

XG-A **CODE No. 2013-300**

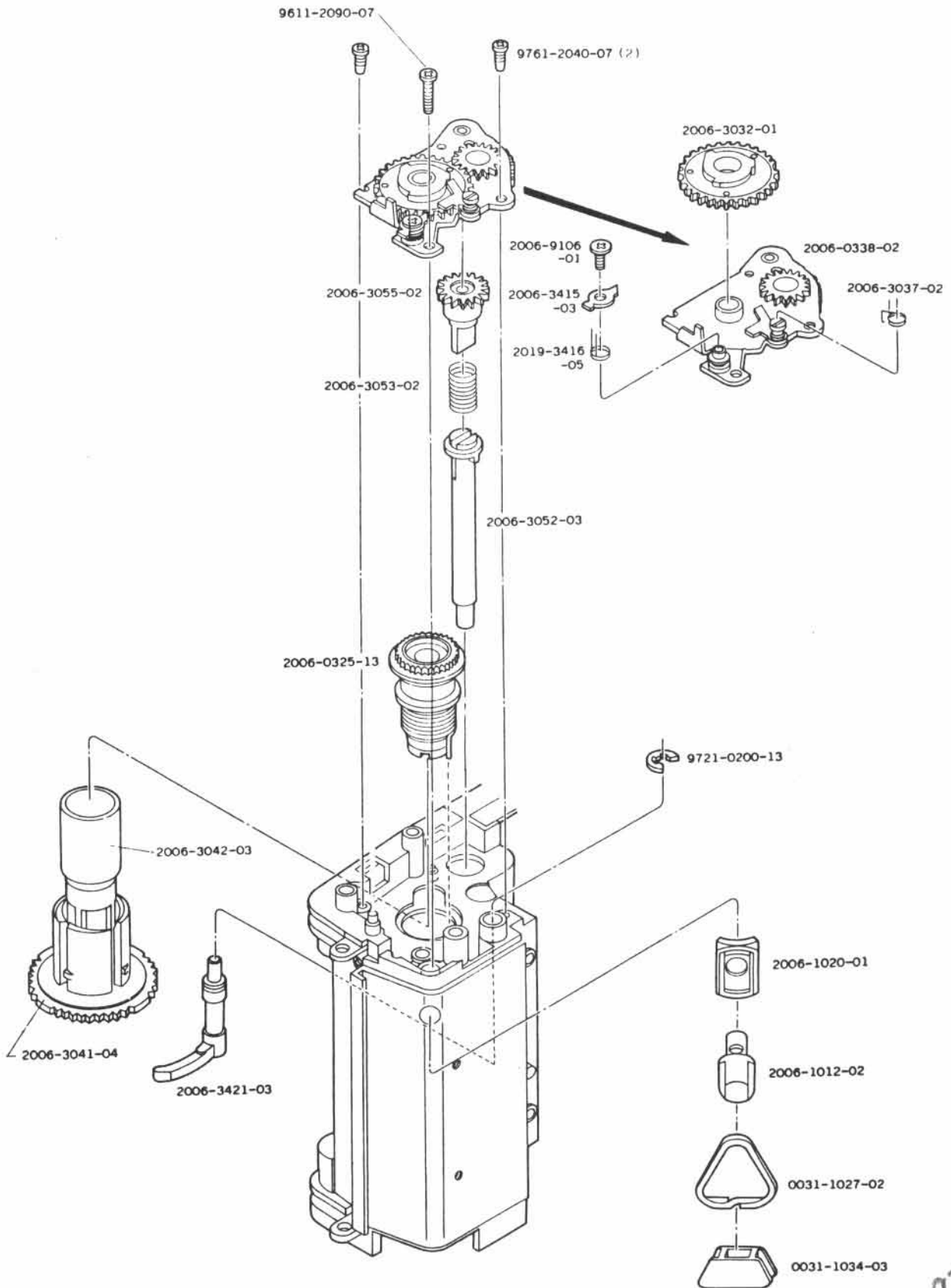

83

Part No.	Part Name		Qty
2006-0325-13	Spool gear set	スプールギヤーセット	1
2006-0338-02	Winding base plate-A set	巻取台板 A セット	1
2006-1012-02	Strap hanger	吊環	1
2006-1020-01	Strap hanger seat	吊環座	1
0031-1027-02	Triangle hanger	三角吊環	1
0031-1034-03	Triangle hanger stopper	三角環回り止め	1
2006-3032-01	Winding gear	巻取ギヤー	1
2006-3037-02	Reversing stop claw spring	逆転防止爪SP	1
2006-3041-04	Spool	スプール	1
2006-3042-03	Spool inner barrel	スプール内筒	1
2006-3052-03	Sprocket shaft	スプロケット軸	1
2006-3053-02	R button release spring	R 釦解除SP	1
2006-3055-02	Sprcket gear	スプロケットギヤー	1
2006-3415-03	Winding operation lever-A	トンボ返りレバー	1
2019-3416-05	Winding operation lever spring	トンボ返りレバーSP	1
2006-3421-03	Film indication filler	フィルム表示ファイラー	1
2006-9106-01	Screw-C	止めねじ	1
9611-2090-07	Phillips type screw	十字穴付なべ頭小ねじ	1
9761-2040-07	Tap tite screw	十字穴付なべ頭タップタイトねじ	2
9721-0200-13	E-ring	E リング	1

XG-A **CODE No. 2013-300**

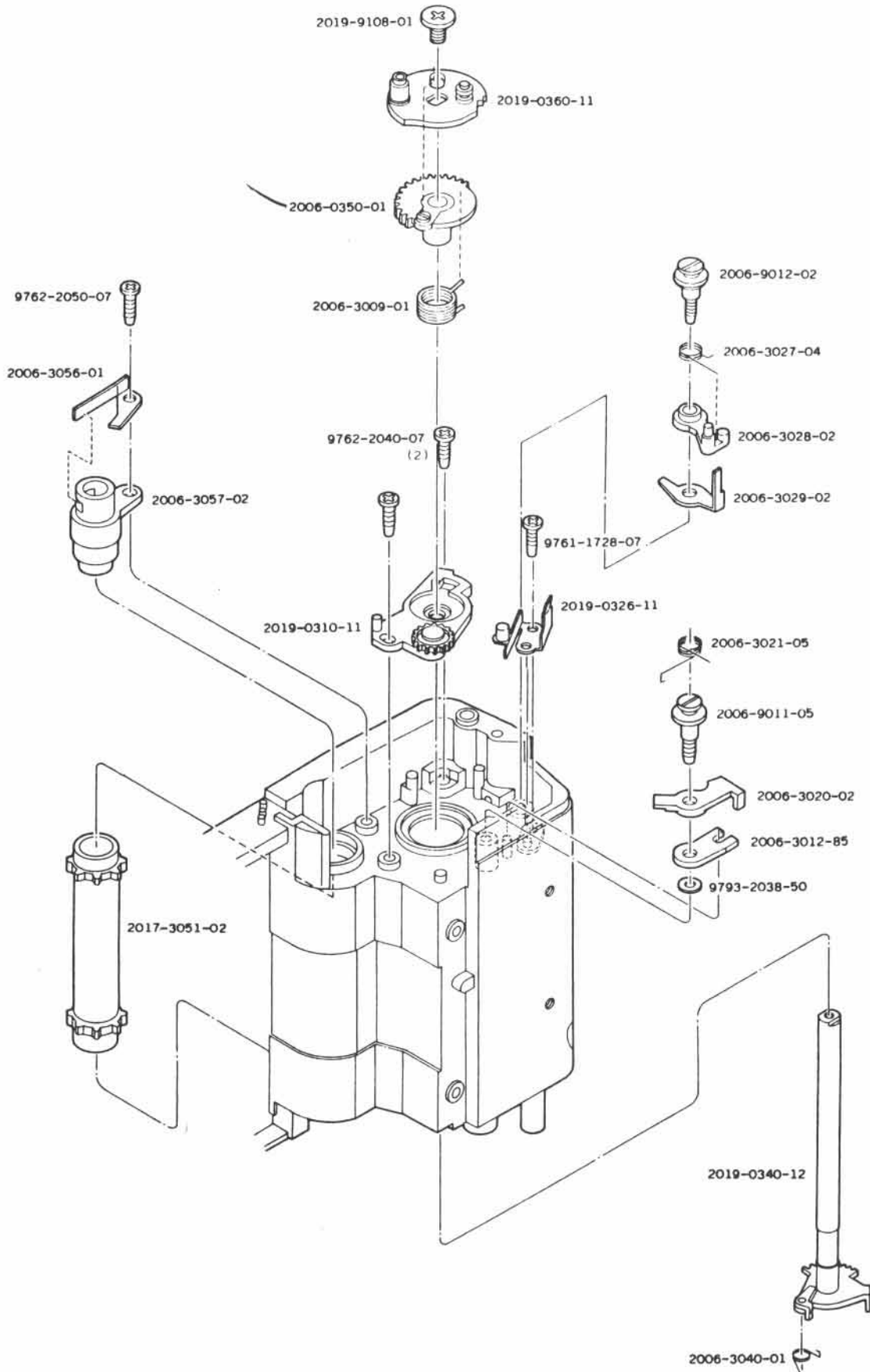

85

Part No.	Part Name		Qty
2019-0310-11	Winding axis receiver set	巻取軸受セット	1
2019-0326-11	S4 contact set	S4 接片セット	1
2019-0340-12	Winding operation plate set	巻取操作板セット	1
2006-0350-01	Shutter charge gear-D set	シャッターチャージギヤーセット	1
2019-0360-11	Charge operation plate set	チャージ操作板セット	1
2006-3009-01	Return spring	戻しSP	1
2006-3012-85	Winding stop lever	巻止めレバー	1
2006-3020-02	Reset lever	リセットレバー	1
2006-3021-05	Reset lever spring	リセットレバースプリング	1
2006-3027-04	S4 spring	S4 SP	1
2006-3028-02	S4 change lever	S4 切換レバー	1
2006-3029-02	S4 lug plate	S4 ラグ板	1
2006-3040-01	Widning claw spring	巻取爪SP	1
2017-3051-02	Sprocket	スプロケット	1
2006-3056-01	R button lock spring	R釦ロックSP	1
2006-3057-02	Sprocket receiver	スプロケット軸受	1
2006-9011-05	Winding stop lever axis	巻止めレバー軸	1
2006-9012-02	S4 change lever axis	S4 切換レバー軸	1
2019-9108-01	Screw	止めねじ	1
9761-1728-07	Tap tite screw	十字穴付なべ頭タップタイトねじ	1
9762-2040-07	Tap tite screw	十字穴付なべ頭タップナイトねじ	2
9762-2050-07	Tap tite screw	十字穴付なべ頭タップタイトねじ	1
9793-2038-50	Washer	薄ワッシャー	1

86

XG-A **CODE No. 2013-300**

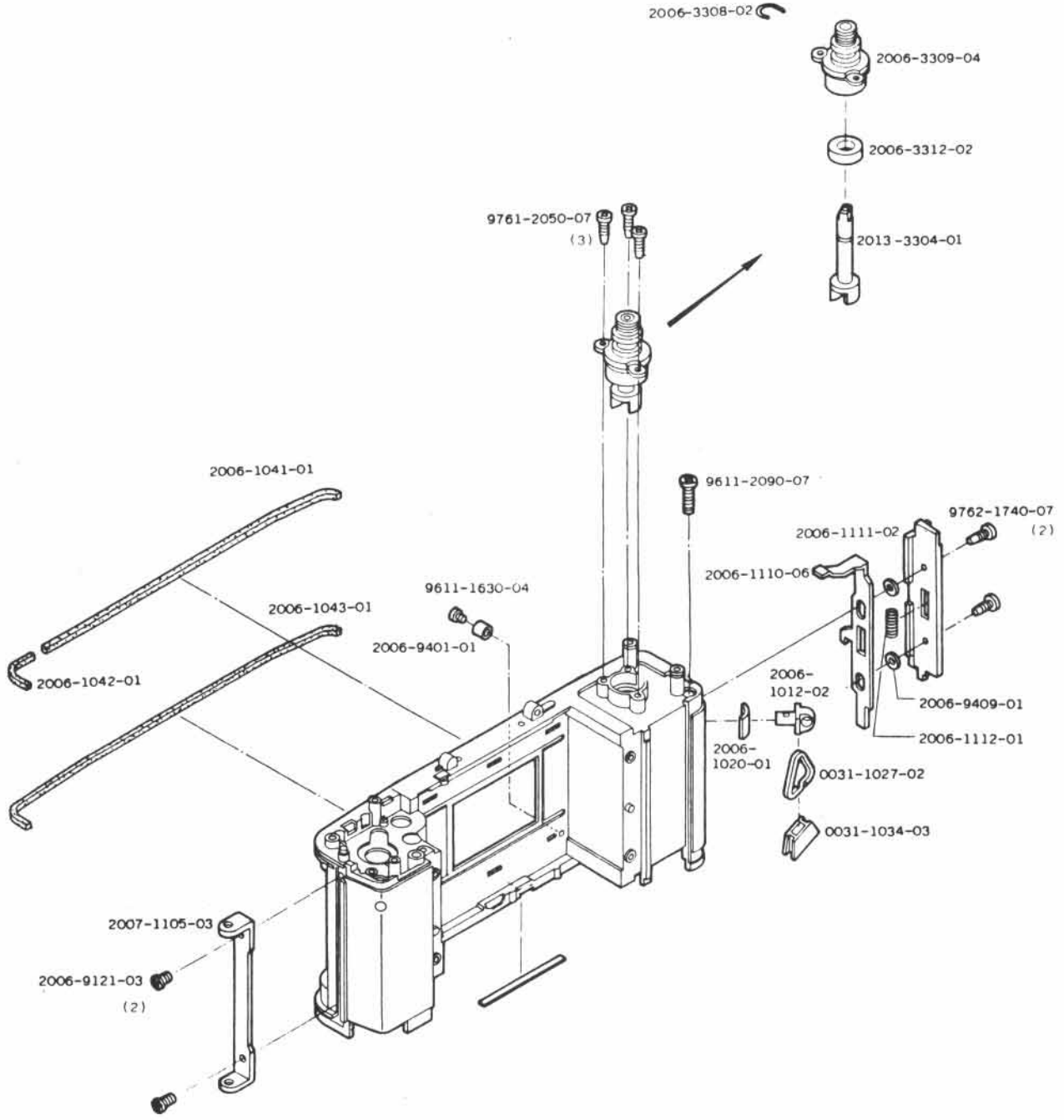

87

Part No.	Part Name		Qty
2006-1012-02	Strap hanger	吊環	1
2006-1020-01	Strap hanger seat	吊環座	1
0031-1027-02	Triangle hanger	三角吊環	1
0031-1034-03	Triangle hanger stopper	三角環回り止め	1
2006-1041-01	Light shield packing-A	遮光パッキンA	1
2006-1042-01	Light shield packing-B	遮光パッキンB	1
2006-1043-01	Light shield packing-C	遮光パッキンC	1
2007-1105-03	Hinge	ヒンジ	1
2006-1110-06	Back cover lock lever	裏蓋ロックレバー	1
2006-1111-02	Lock cover	ロックカバー	1
2006-1112-01	Back cover lock spring	裏蓋ロックSP	1
※2013-3304-01	Rewinding fork	巻戻しフオーク	1
2006-3308-02	Rewinding friction spring	巻戻しフリクションSP	1
2006-3309-04	Rewinding axis receiver	巻戻し軸受	1
2006-3312-02	Light shield collar	巻戻し遮光カラー	1
2006-9121-03	Tapping screw	止めねじ	2
2006-9401-01	Film guide collar	フィルムガイドカラー	1
2006-9409-01	Back cover lock guide	裏蓋ロックガイド	2
9611-1630-04	Phillips type screw	十字穴付なべ頭小ねじ	1
9611-2090-07	Phillips type screw	十字穴付なべ頭小ねじ	1
9761-2050-07	Tap tite screw	十字穴付なべ頭タップタイトねじ	3
9762-1740-07	Tap tite screw	十字穴付なべ頭タップタイトねじ	2

※:Parts for only 2013-300(XG-A)

※印は2013-300 (XG-A) 専用部品

XG-A CODE No. 2013-300

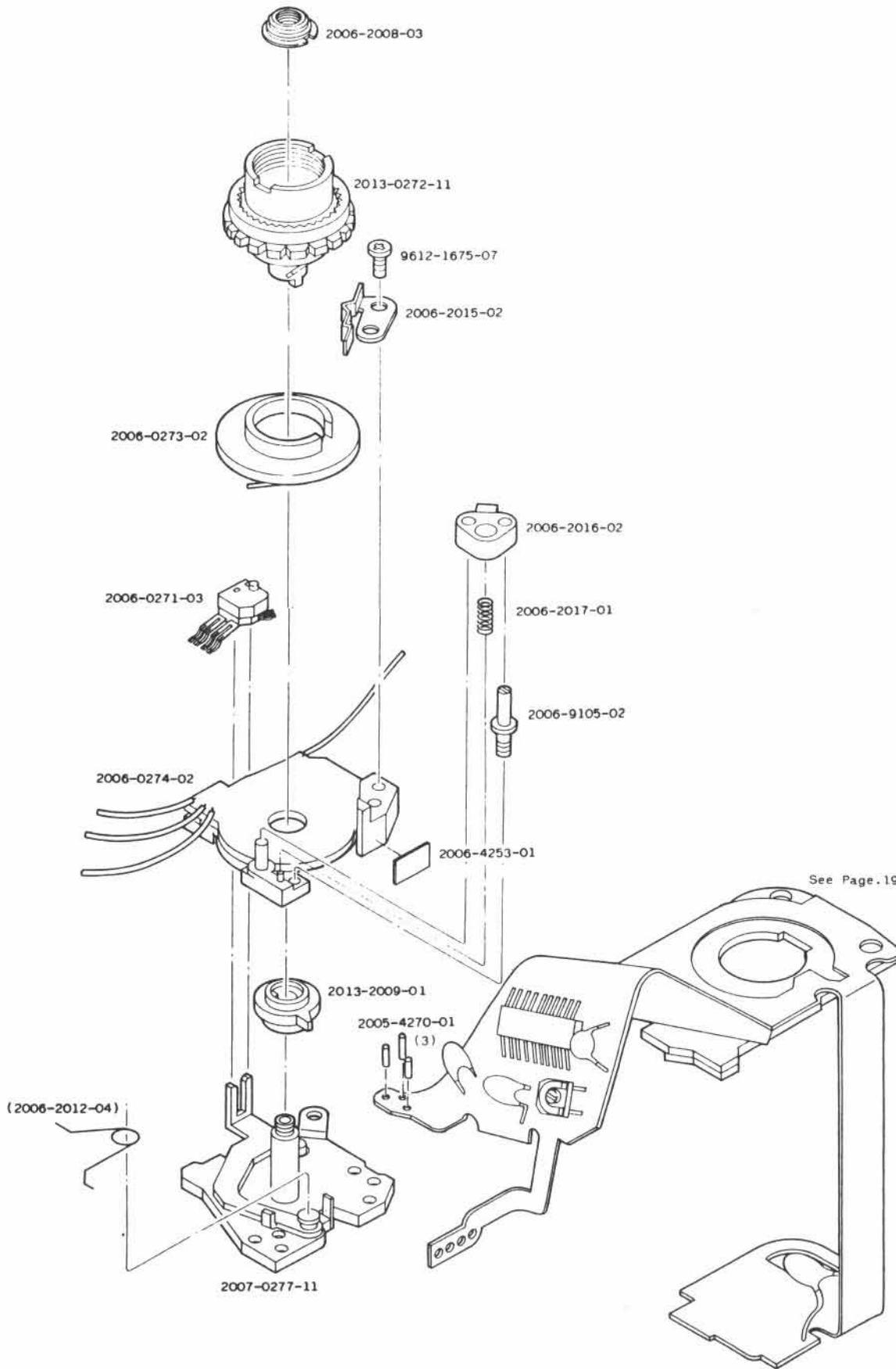

Part No.	Part Name		Qty
2006-0271-03	AM change holer set	AM切換ホルダーセット	1
2013-0272-11	Dial axis set	ダイヤル軸セット	1
2006-0273-02	ASA brush holder set	ASAブラシホルダーセット	1
2006-0274-02	ASA resistorset	回路基板Aセット	1
2007-0277-11	Shutter speed dial base plate set	シャッターダイヤル台板セット	1
(2006-2012-04)	AM change spring	AM切換SP	1
2006-2008-03	Shutter speed dial pressure	シャッターダイヤル押え	1
2013-2009-01	Cam plate	カム板	1
2006-2015-02	Click spring	クリックSP	1
2006-2016-02	Auto lock plate	オートロック板	1
2006-2017-01	Auto lock spring	オートロックSP	1
2006-4253-01	Tape-B	フレキ接着テープ	1
2005-4270-01	Jamp lead (φ0.4 ℓ=3mm)	ジャンプリード	3
2006-9105-02	Auto lock plate guide	オートロック板ガイド	1
9612-1675-07	Phillips type screw	十字穴付なべ頭小ねじ	1

XG-A **CODE No. 2013-300**

Assy. Part No. 2006-0222-11

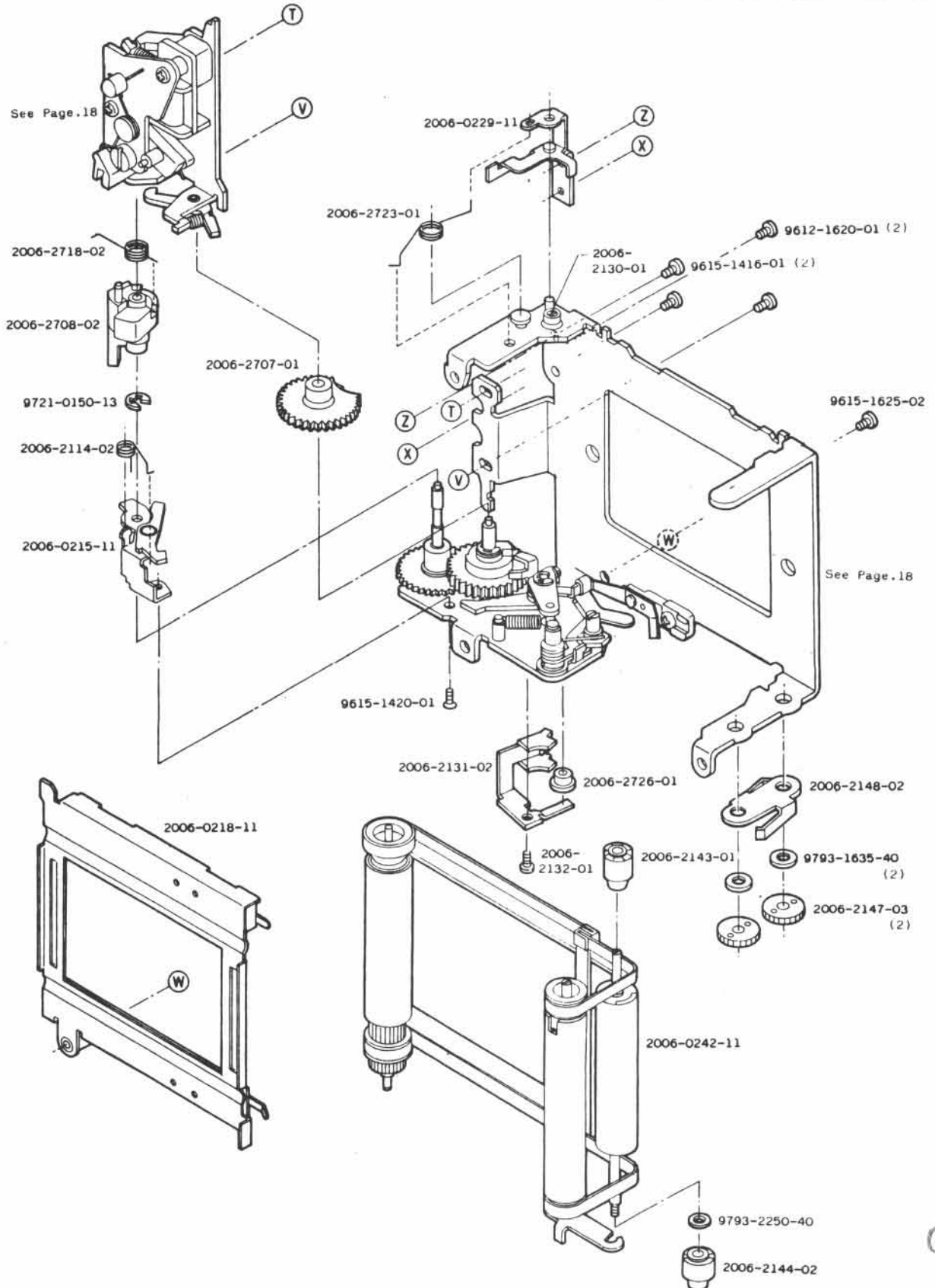

91

Part No.	Part Name		Qty
2006-0222-11	Shutter complete set	シャッターブロック	1
2006-0215-11	1st curtain stop lever set	一幕係止レバーセット	1
2006-0218-11	Shutter cover set	シャッターカバー板セット	1
2006-0229-11	2nd curtain stop lever set	二幕係止レバーセット	1
2006-0242-11	Shutter curtain set	シャッター幕セット	1
2006-2114-02	First curtain stop lever spring	一幕係止レバーSP	1
2006-2130-01	Adjusting screw	幕調整ねじ	1
2006-2131-02	Curtain ribbon guide plate	幕リボンガイド板	1
2006-2132-01	Ribbon guide plate screw	止めねじ	1
2006-2143-01	2nd curtain roller-A	二幕ローラーA	1
2006-2144-02	2nd curtain roller-B	二幕ローラーB	1
2006-2147-03	Ratchet	幕スプリング筒軸止めラチエット	2
2006-2148-02	Ratcher stop spring	ラチエット止めSP	1
2006-2707-01	2nd curatin shutter gear	二幕シャッターギヤー	1
2006-2708-02	Control cam	制御カム	1
2006-2718-02	Control cam operation spring	制御カム駆動SP	1
2006-2723-01	2nd curtain stop lever spring	二幕係止レバーSP	1
2006-2726-01	Curtain shaft receiver-B	幕軸受 B	1
9612-1620-01	Phillips type screw	十字穴付なべ頭小ねじ	2
9615-1416-01	Phillips type screw	十字穴付皿頭小ねじ	2
9615-1420-01	Phillips type screw	十字穴付皿頭小ねじ	1
9615-1625-02	Phillips type screw	十字穴付皿頭小ねじ	1
9721-0150-13	E-ring	Eリング	1
9793-1635-40	Washer	薄ワッシャー	2
9793-2250-40	Washer	薄ワッシャー	1

XG-A **CODE No. 2013-300**

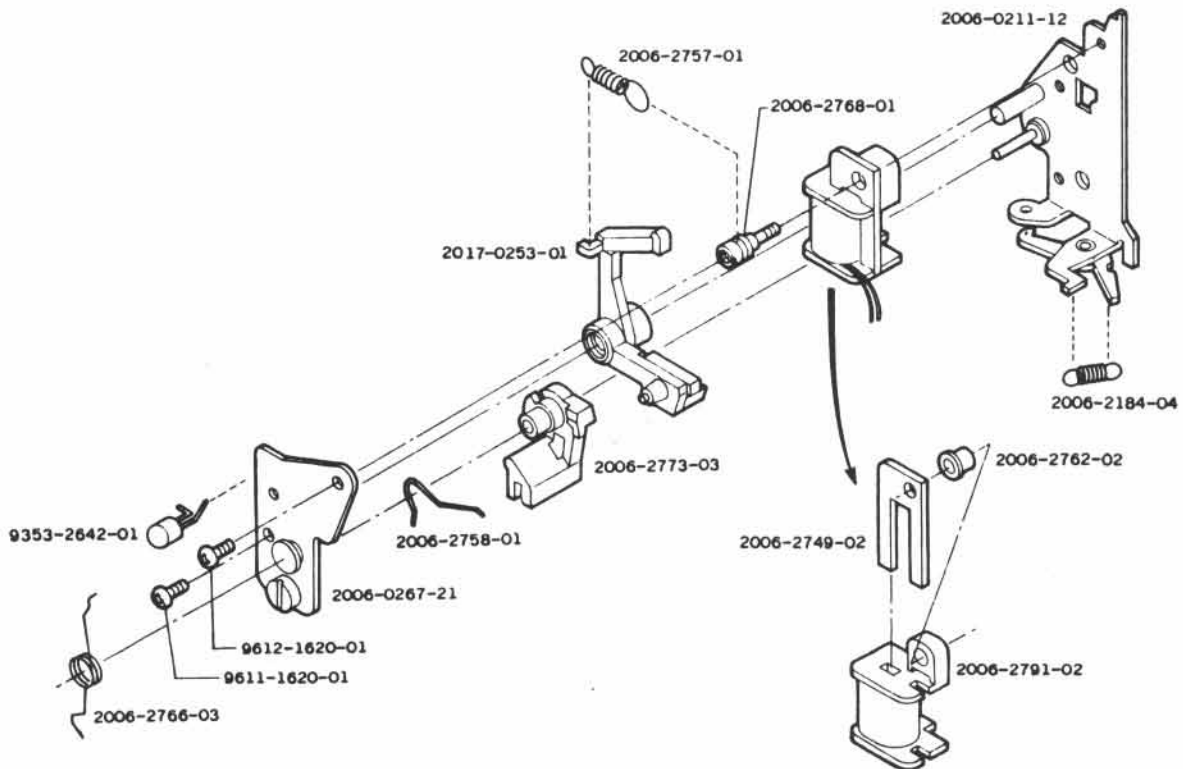
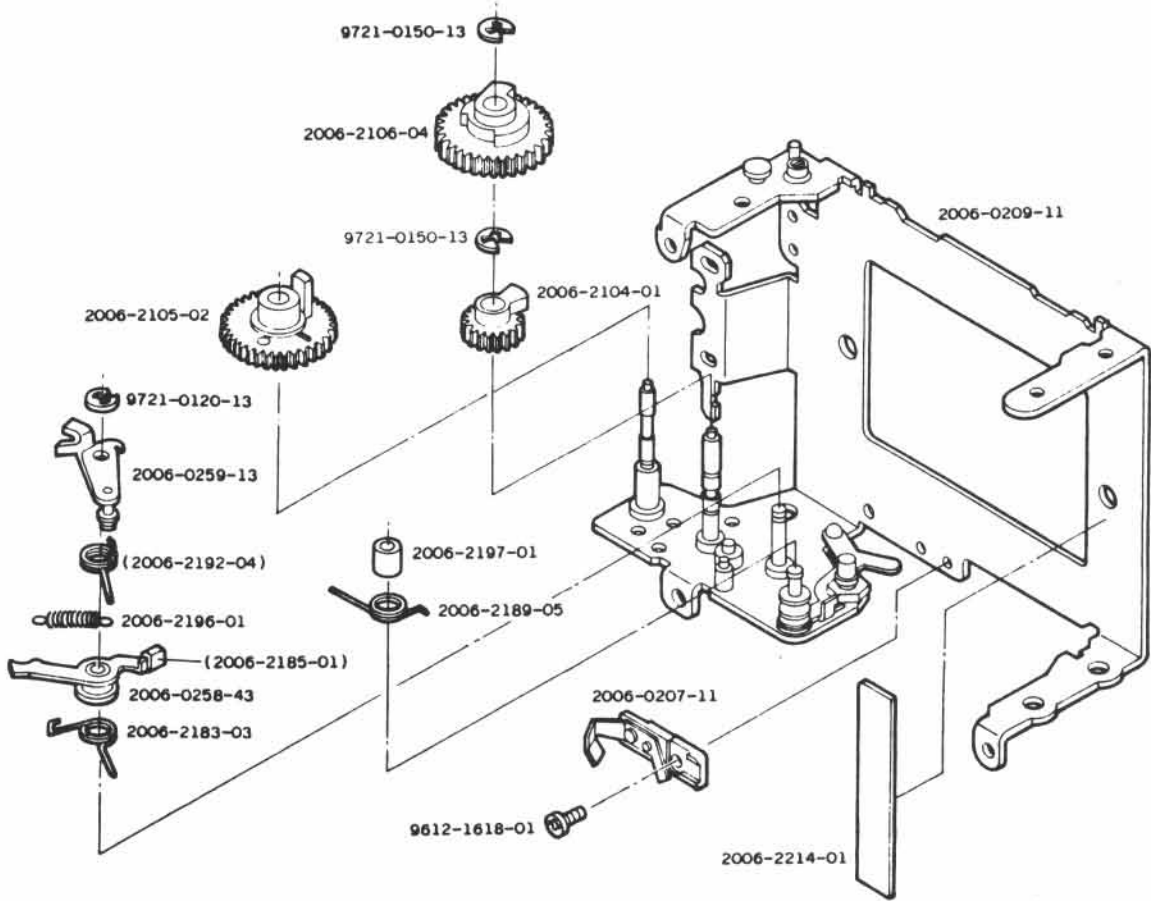

93

Part No.	Part Name		Qty
2006-0207-11	X contact plate set	X 接片セット	1
2006-0209-11	Shutter base plate set	シャッター台板セット	1
2006-0211-12	Control base plate set	制御台板セット	1
2017-0253-01	2nd curtain release lever set	二幕解除レバーセット	1
2006-0258-43	1st curtain brake lever set	一幕ブレーキレバーセット	1
(2006-2185-01)	Brake lever isolation collar	一幕ブレーキ絶縁カラー	1
2006-0259-13	2nd curtain brake lever set	二幕ブレーキレバーセット	1
(2006-2192-04)	2nd curtain brake spring	二幕ブレーキSP	1
2006-0267-21	Wiring base plate set	Mg 配線基板セット	1
2006-2104-01	Charge gear-B	チャージギヤーB	1
2006-2105-02	Charge gear-A	チャージギヤーA	1
2006-2106-04	1st curtain shutter gear	一幕シャッターギヤー	1
2006-2183-03	1st curtain brake spring-B	一幕ブレーキ SP-B	1
2006-2184-04	2nd curtain brake spring	制御カム係止レバーSP	1
2006-2189-05	X lever spring	X レバーSP	1
2006-2196-01	2nd curtain brake return spring	二幕ブレーキ戻しSP	1
2006-2197-01	Brake lever axis collar	二幕ブレーキ消音カラー	1
2006-2214-01	Tape	幕緑金保護テープ	1
2006-2749-02	Shutter magnet core	シャッターマグネット鉄芯	1
2006-2757-01	2nd curtain release lever spring	二幕解除レバーSP	1
2006-2758-01	Over charge spring	吸着片オーバーチャージSP	1
2006-2762-02	Magnet collar	マグネット取付カラー	1
2006-2766-03	Trigger contact	トリガー接片	1
2006-2768-01	Trigger base plate screw	止めねじ	1
2006-2773-03	Trigger contact operation lever	トリガー接片作動レバー	1
2006-2791-02	Shutter magnet bobbin	シャッターマグネットボビン	1
9611-1620-01	Phillips type screw	十字穴付なべ頭小ねじ	1
9612-1618-01	Phillips type screw	十字穴付なべ頭小ねじ	1
9612-1620-01	Phillips type screw	十字穴付なべ頭小ねじ	1
9721-0120-13	E-ring	E リング	1
9721-0150-13	E-ring	E リング	2
◎ 9353-2642-01	L.E.D (TLR108)	L.E.D (LD13)	1

◎ L.E.D はシャッターブロックに含まれません
 ◎ The LED is excluded on the shutter block.

XG-A CODE No. 2013-300

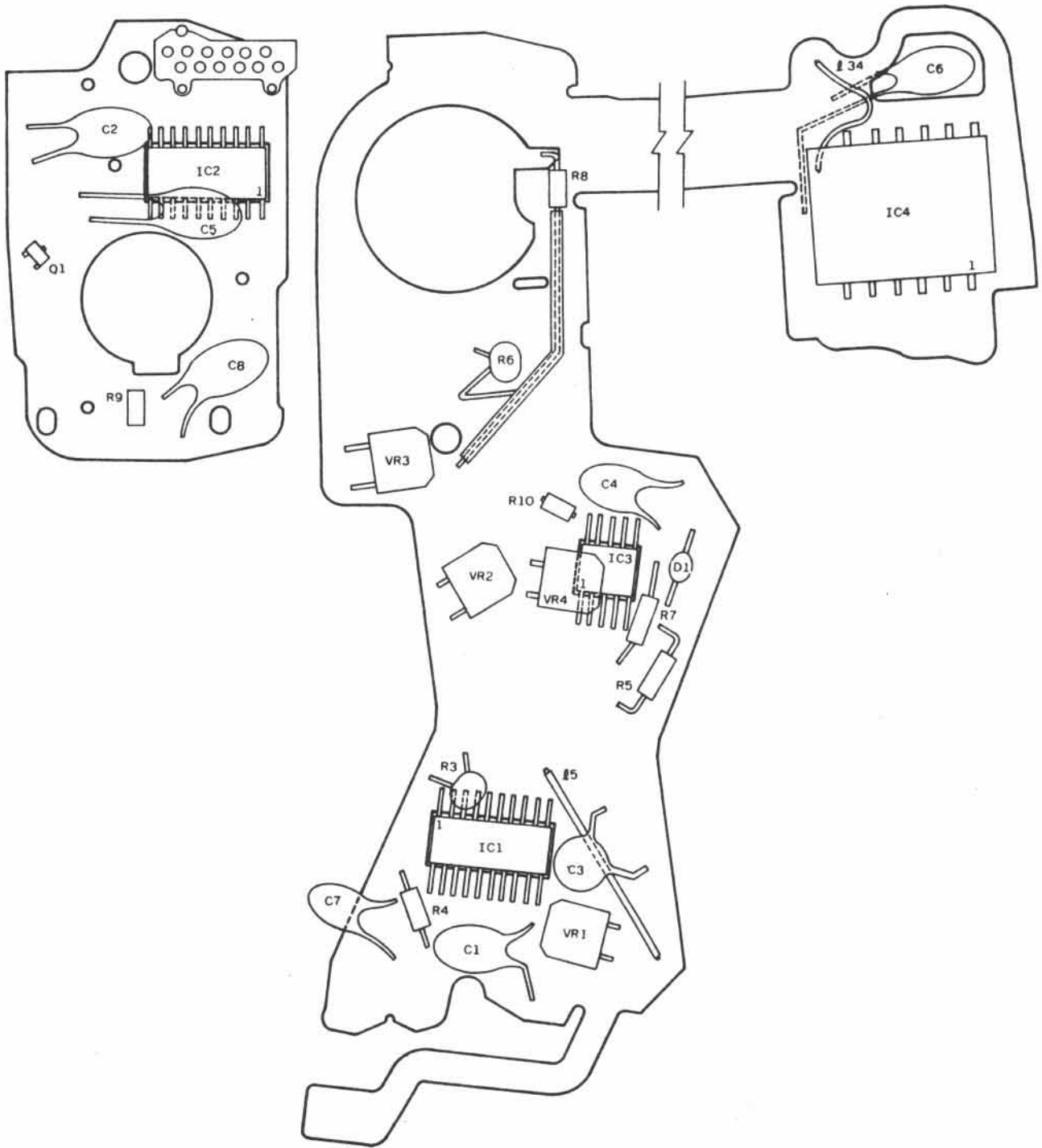

※
 Assy Part No. 2013-0403-01 Assy. Part Name Flexible P.C. board set
 フレキシブル基板セット

Symbol	Part No.	Com	Part Name	Type.	Qty	
IC1	2006-4301-03		I C	M51865	1	
IC2	2006-4302-03			M51866	1	
IC3	2006-4303-03			M51867	1	
IC4	2006-4304-07			HIC	1	
D1	9361-5631-01		Diode	KB162	1	
Q1	9363-1032-01	02,03	Transistor	2SA1162	1	
R3	9431-1037-31		Fixed resistor	1/16W 10K Ω	1	
R5	9422-1046-32			1/8W 100K Ω	1	
R6	9431-3047-31			1/16W 300K Ω	1	
R7	9422-6806-32			1/8W 68 Ω	1	
R8	9422-3916-32			1/8W 390 Ω	} 1	
	9422-8216-32			1/8W 820 Ω		
	9422-1826-32			1/8W 1.8K Ω		
	9422-3326-32			1/8W 3.3K Ω		
Q4	2006-8408-01			Lead wire Pink		ϕ 0.08/7 wires $l=35$ mm
R9	9422-3016-62			Fixed resistor	1/8W 300 Ω	1
R10	9422-2416-62		1/8W 240 Ω		2	
VR1	9472-1059-38			VGO62K 1M Ω	1	
VR3	VR2	9472-1539-38		VGO62K 15K Ω	2	
VR4	9472-1529-38			VGO62K 1.5K Ω	1	
C1	9535-1555-36		Condenser	1.5 μ F/35V	1	
C2	9535-6845-31			0.68 μ F/35V	1	
C3	9563-4738-31			0.047 μ F1.2V	1	
C4	9531-2265-31			22 μ F/3.15V	1	
C5	9531-4765-31			47 μ F/3.15V	1	
C6	9531-1575-61			150 μ F/3.15V	1	
C7	9534-1555-33	or		1.5 μ F/25V	} 1	
	9534-1555-63	or		1.5 μ F/20V		
	9535-1555-31		1.5 μ F/35V			
C8	9531-3365-31			33 μ F/3.15V	1	
Q5	2006-8403-01		Lead wire Blue	ϕ 0.08/7 wires $l=27$ mm	1	
Q34	2006-8403-01		Lead wire Blue	ϕ 0.08/7 wires $l=20$ mm	1	

■ The R4 is excluded on the Flexible P.C. board set

■ R4は0403 (フレキセット) には含まれません。

R4	9422-2036-39	Fixed resistor (for adjustment)	1/8W 20K Ω	} 1
	9422-2236-39		1/8W 22K Ω	
	9422-2436-39		1/8W 24K Ω	
	9422-2736-39		1/8W 27K Ω	
	9422-3036-39		1/8W 30K Ω	
	9422-3336-39		1/8W 33K Ω	
	9422-3936-39		1/8W 39K Ω	
	9422-4736-39		1/8W 47K Ω	
	9422-5636-39		1/8W 56K Ω	
	9422-6836-39		1/8W 68K Ω	
	9422-1046-39		1/8W 100K Ω	
	9422-2046-39		1/8W 200K Ω	

※:Parts for only 2013-300(XG-A)

※印は2013-300 (XG-A) 専用部品

Download from www.Somanuals.com. All Manuals Search And Download.

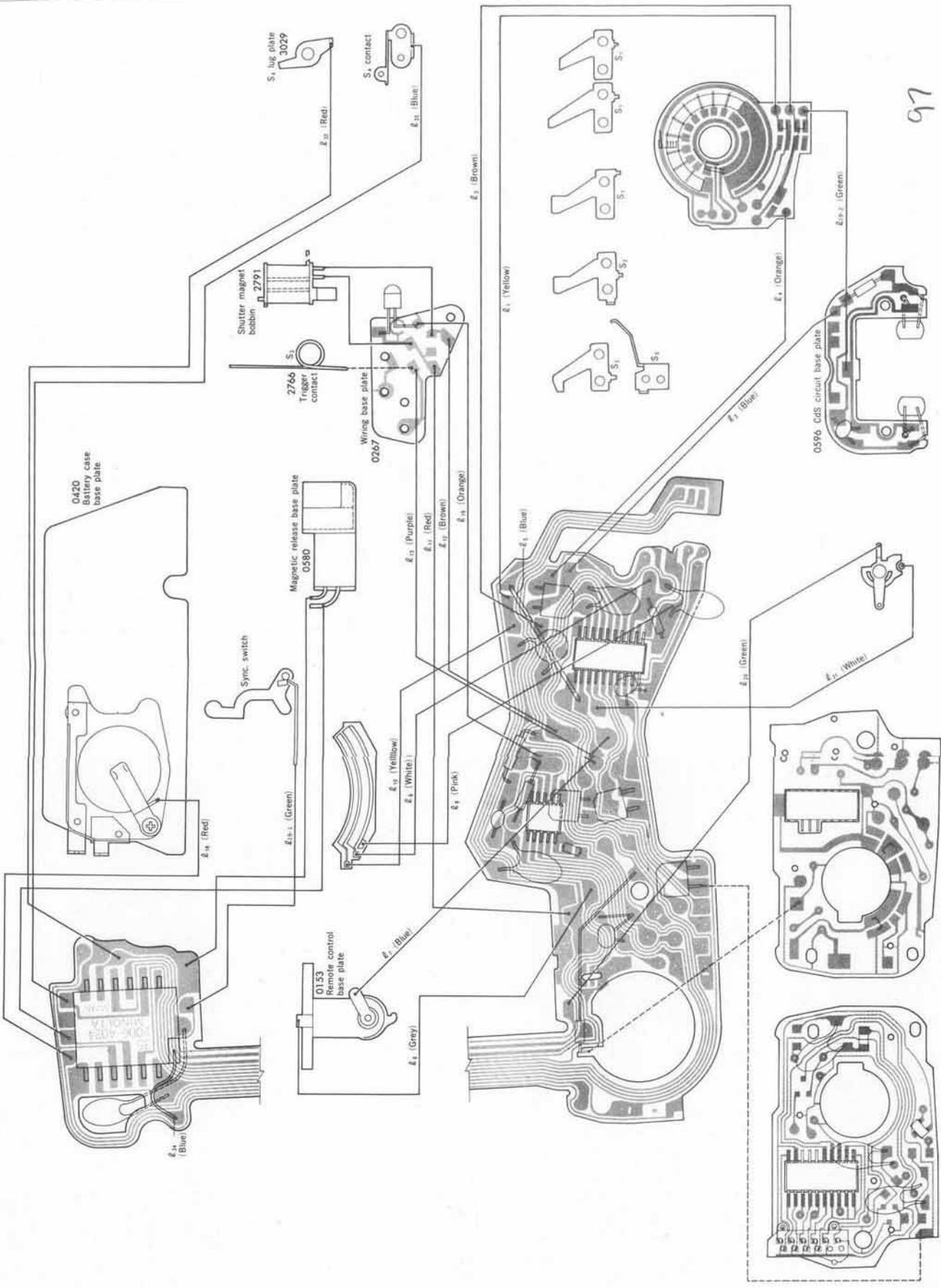

Lead wires list

Symbol	Part No.	Color	Typ.	Qty.
l1	2006-8401-01	Yellow	ø0.08/7 wires l=70	1
l2	2006-8402-01	Brown	ø0.08/7 wires l=70	1
l3	2006-8403-01	Blue	ø0.08/7 wries l=45	1
l4	2006-8404-01	Orange	ø0.08/7 wires l=40	1
l5	2006-8403-01	Blue	ø0.08/7 wires l=27	1
l6	2006-8406-01	Grey	ø0.08/7 wires l=110	1
l7	2006-8403-01	Blue	ø0.08/7 wires l=118	1
l8	2006-8408-01	Pink	ø0.08/7 wires l=75	1
l9	2006-8409-01	White	ø0.08/7 wires l=85	1
l10	2006-8401-01	Yellow	ø0.08/7 wires l=95	1
l11	2006-8411-01	Red	ø0.08/7 wires l=110	1
l12	2006-8402-01	Brown	ø0.08/7 wires l=100	1
l13	2006-8413-01	Purple	ø0.08/7 wires l=100	1
l16	2006-8404-01	Orange	ø0.08/7 wires l=115	1
l18	2006-8411-01	Red	ø0.08/7 wires l=60	1
l19-2 l19-1	2006-8417-01	Green	ø0.08/7 wires l=65	2
l21	2006-8409-01	White	ø0.08/7 wires l=65	1
l29	2006-8417-01	Green	ø0.08/7 wires l=80	1
l32	2006-8411-01	Red	ø0.08/7 wires l=150	1
l33	2006-8403-01	Blue	ø0.08/7 wires l=150	1
l34	2006-8403-01	Blue	ø0.08/7 wires l=20	1

REPAIR GUIDE

The changes from 2006 (XG-2, XG-7, XG-E) include the omission of manual shutter speed and the simplification of indication LED in viewfinder.

For the adjustments and checks other than those mentioned in this manual, refer to the Service Manual of 2006.

■ Check and adjustment of indication LED	P. 1
■ Check of curtain speed	P. 2
■ Adjustment of auto exposure	
① Measurement of CdS resistance value and selection of R_1 , R_2	P. 3
② Selection of R_4	P. 5
③ Adjustment of EE	P. 6
④ Adjustment of LED indication	P. 7
■ Adjustment of X shutter speed	P. 8
■ Check of synchro time lag	P. 8
■ Check of high luminance non-interlock lock	P. 9
■ Check of flash function	P. 10
■ Check and adjustment of shutter block performance	
① Check of magnet attraction	P. 12
② Check of curtain speed	P. 12
③ Check of manual second	P. 13
④ Check of minimum operation voltage	P. 13
⑤ Check of curtain bound	P. 13
⑥ Check of synchro time lag	P. 14
■ Measuring instruments & tools	P. 15

■ Check and adjustment of indication LED

■ Measuring instrument : Camera standard tester (MODEL ST-5101)

■ How to check

1. Remove the 2 leads (green, blue) of CdS board and connect them to the tester as shown below.

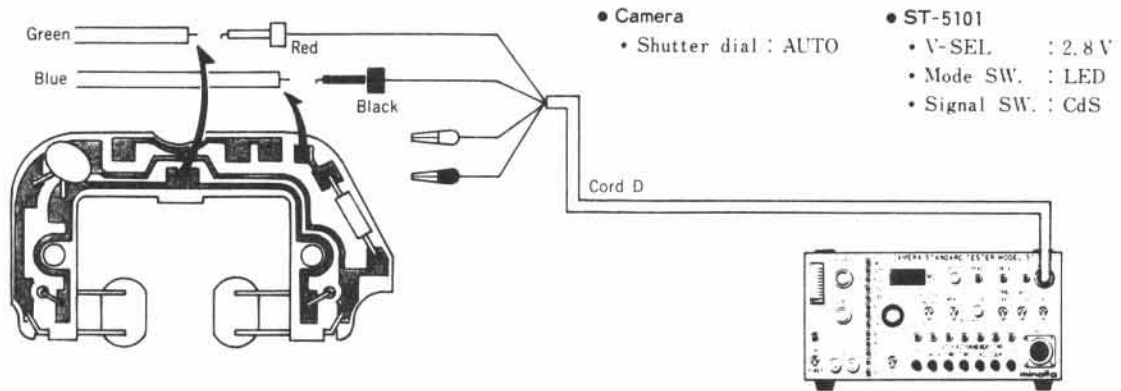

2. Turn ON the metering switch (S_1), and adjust the ASA dial so that the indication LED lights up continuously from ∇ (low luminance warning) to \triangle (high luminance warning).
3. Looking into the viewfinder, make sure that the range from ∇ to \triangle can be seen clearly without shading.
4. If the view is shaded, adjust according to the adjusting procedure given below.

■ Adjusting procedure

1. With the tester connected, loosen the LED board setscrew shown below and move the board in the direction of the arrow until the range from ∇ to \triangle can be seen clearly and evenly, and then tighten the setscrew.

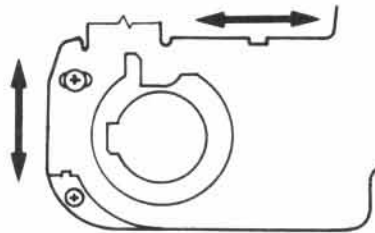

■ Check of curtain speed

■ Measuring instrument : Shutter tester (MODEL S-2101, FS1D-MN4)

■ Standard	Curtain speed	10.8~11.2 ms (both 1st & 2nd curtains)	※ Measuring speed: 1/1000
	Unevenness	Within 0.3 ms (difference between A and C ranges)	

※ In the case of 2006, it is checked at manual 1/1000, but in 2013, having no manual SS, operate the camera in auto mode using the light source of shutter tester and adjust the shutter speed nearly to 1/1000 by the MC ring.

■ Checking procedure

1. Set the camera on the shutter tester, release the shutter several times while turning the MC ring clock-wise, then hold the MC ring with the finger when the indication of B range is 0.7 ms~1.5 ms.

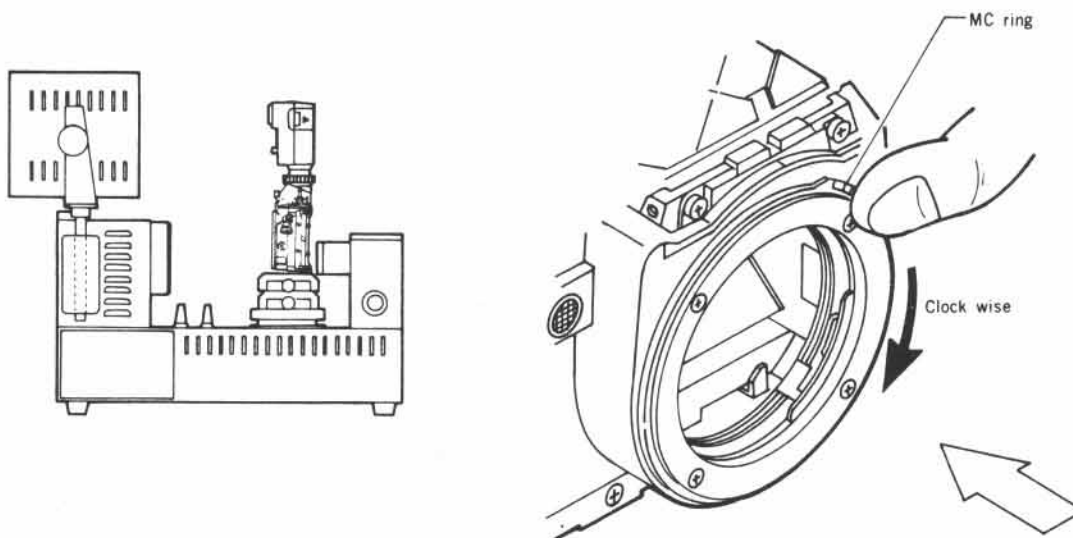

- Do not interrupt the shutter tester light with the finger during measurement.
 - When the shutter is not released, the high luminance lock might be in action.
2. Release the shutter several times and check if the curtain speed is within the standard mentioned above.
If not, perform the adjustment on P.12.

101

Adjustment of auto exposure

Adjustment of variable and fixed resistors.

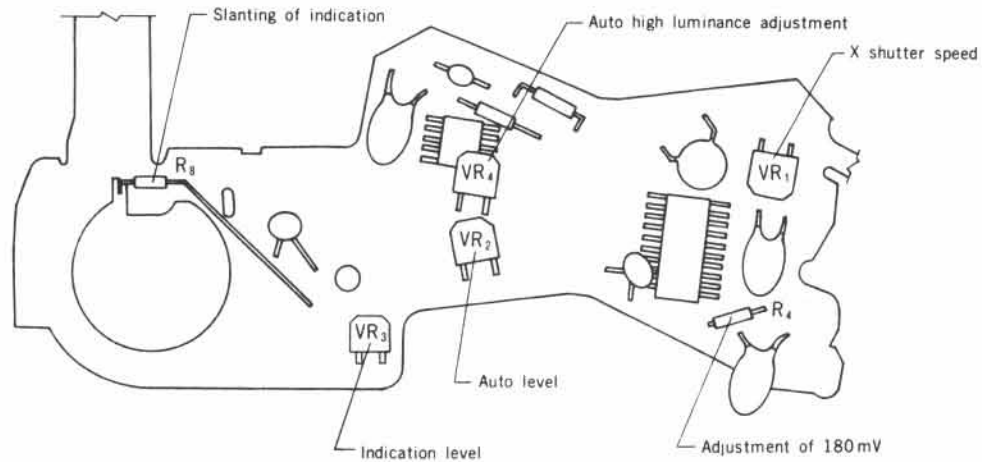

1 Measurement of CdS resistance value and selection of R_1 , R_2

- Measuring instruments :** Luminance box (MODEL L-2101, L-222, L-223)
 : Digital multimeter (Type 2508, 3476, 2507)
 : Standard lens (50 mm/F 1.4)

Measuring procedure

1. Remove the lead (green) of CdS board and R_1 , R_2 as shown below. Solder the 2 measuring leads to the part of R_1 , and make the connection to the tester.

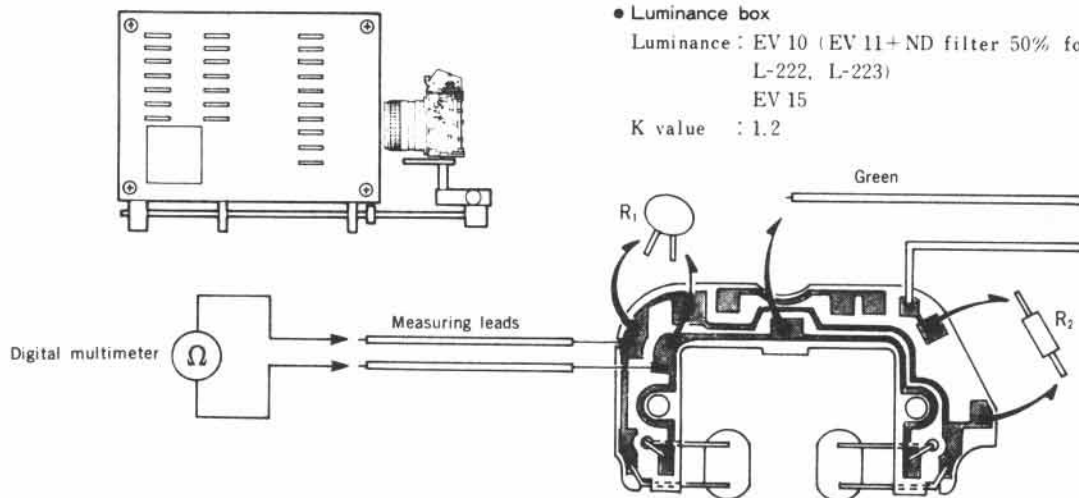

2. Measurement of RBV 5 (If the measured value is outside the range from 12 to 40 Kohm, replace CdS.)
 Measure the resistance value with the luminance box set to EV 10 (EV 11+ND filter 50% for L-222, L-223).
3. Measurement of RBV 10 (If the measured value is outside the range from 1.6 to 5.6 Kohm, replace CdS.)
 Measure the resistance value with the luminance box set to EV 15.

Selection of R_1 , R_2

Decide R_1 and R_2 from the measured values (or approximate values) of RBV 5 and RBV 10 with reference to the table on the next page, and fit them on the CdS board.

[Example] When the measured values are $R_{BV\ 5} = 23\text{ Kohm}$, $R_{BV\ 10} = 3.4\text{ Kohm}$, then $R_1 = 820\text{ Kohm}$, $R_2 = 0.56\text{ Kohm}$ can be attained from the point of intersection between the vertical and horizontal axes.

R_{BV}	10		
$R_{BV\ 5}$		3.2	3.4
	22		
	23		$\frac{820}{0.56}$

■ Calculation Table

R_{BV}	$R_{BV\ 5}$	1.6	1.8	2	2.2	2.4	2.6	2.8	3	3.2	3.4	3.6	3.8	4	4.2	4.4	4.6	4.8	5	5.2	5.4	5.6	
12		$\frac{330}{0.47}$	$\frac{470}{0.33}$	$\frac{1000}{0.22}$																			
13			$\frac{390}{0.47}$	$\frac{560}{0.27}$	$\frac{1200}{0}$																		
14			$\frac{330}{0.56}$	$\frac{470}{0.47}$	$\frac{680}{0.21}$																		
15			$\frac{330}{0.68}$	$\frac{390}{0.56}$	$\frac{560}{0.39}$	$\frac{820}{0.27}$																	
16			$\frac{270}{0.82}$	$\frac{390}{0.68}$	$\frac{470}{0.56}$	$\frac{680}{0.39}$	$\frac{1000}{0.22}$																
17			$\frac{330}{1.0}$	$\frac{330}{0.82}$	$\frac{390}{0.68}$	$\frac{560}{0.56}$	$\frac{680}{0.39}$	$\frac{1200}{0.22}$															
18				$\frac{330}{1.0}$	$\frac{390}{0.82}$	$\frac{470}{0.68}$	$\frac{680}{0.56}$	$\frac{820}{0.39}$	$\frac{1500}{0.22}$														
19					$\frac{390}{1.0}$	$\frac{470}{0.82}$	$\frac{560}{0.68}$	$\frac{680}{0.56}$	$\frac{1000}{0.39}$														
20			$\frac{270}{1.5}$		$\frac{330}{1.0}$	$\frac{390}{0.82}$	$\frac{470}{0.68}$	$\frac{560}{0.47}$	$\frac{820}{0.33}$	$\frac{1200}{0.33}$													
21				$\frac{330}{1.2}$		$\frac{470}{1.0}$	$\frac{560}{0.82}$	$\frac{680}{0.68}$	$\frac{1000}{0.47}$	$\frac{1200}{0.33}$													
22					$\frac{330}{1.5}$		$\frac{390}{1.0}$	$\frac{560}{1.0}$	$\frac{680}{0.82}$	$\frac{820}{0.68}$	$\frac{1000}{0.47}$	$\frac{1500}{0.33}$											
23						$\frac{470}{1.0}$		$\frac{680}{0.82}$	$\frac{820}{0.56}$	$\frac{1200}{0.47}$													
24							$\frac{470}{1.2}$		$\frac{680}{1.0}$	$\frac{820}{0.82}$	$\frac{1000}{0.56}$	$\frac{1200}{0.47}$											
25								$\frac{560}{1.0}$	$\frac{680}{0.82}$	$\frac{820}{0.82}$	$\frac{1000}{0.56}$	$\frac{1500}{0.47}$											
26									$\frac{470}{1.2}$	$\frac{680}{1.0}$	$\frac{820}{0.68}$	$\frac{1000}{0.56}$	$\frac{1200}{0.39}$										
27										$\frac{390}{1.8}$	$\frac{470}{1.5}$	$\frac{560}{1.2}$	$\frac{680}{1.2}$	$\frac{680}{1.0}$	$\frac{820}{0.82}$	$\frac{1000}{0.68}$	$\frac{1200}{0.56}$						
28												$\frac{820}{1.0}$	$\frac{1000}{0.82}$	$\frac{1200}{0.68}$	$\frac{1500}{0.56}$								
29													$\frac{680}{1.0}$	$\frac{820}{0.82}$	$\frac{1000}{0.68}$	$\frac{1200}{0.56}$	$\frac{1500}{0.56}$						
30														$\frac{680}{1.5}$	$\frac{680}{1.2}$	$\frac{1000}{1.0}$	$\frac{1000}{0.82}$	$\frac{1200}{0.68}$					
31															$\frac{560}{1.5}$	$\frac{820}{1.2}$	$\frac{820}{1.0}$	$\frac{1200}{0.82}$	$\frac{1500}{0.68}$				
32																$\frac{560}{1.8}$	$\frac{820}{1.0}$	$\frac{1000}{1.0}$	$\frac{1200}{0.82}$	$\frac{1500}{0.68}$			
33																	$\frac{820}{1.5}$	$\frac{1200}{0.82}$					
34																		$\frac{820}{1.2}$	$\frac{1200}{1.0}$	$\frac{1500}{0.83}$			
35																			$\frac{680}{1.5}$	$\frac{820}{1.5}$	$\frac{1000}{1.2}$	$\frac{1000}{1.0}$	$\frac{1500}{0.82}$
36																				$\frac{680}{1.8}$	$\frac{1000}{1.5}$	$\frac{1000}{1.2}$	$\frac{1500}{1.0}$
37																					$\frac{820}{1.5}$	$\frac{1200}{1.0}$	$\frac{1500}{0.82}$
38																					$\frac{820}{1.8}$	$\frac{1000}{1.2}$	$\frac{1200}{1.0}$
39																						$\frac{1000}{1.5}$	$\frac{1200}{1.2}$
40																							$\frac{1000}{1.8}$

Top: R_1 (K Ω) in \square
 Bottom: R_2 (K Ω)

2 Selection of R_4 — Adjustment of 180 mV—

- Measuring instruments : Rp resistance selector (MODEL RS-IV, III, II, I)
: Digital multimeter (Type 2508, 3407, 2507)

■ Standard : $180 \pm \frac{2}{4}$ mV

■ Adjusting procedure

1. Remove R_4 and solder the 2 measuring leads to R_4 , then make the connection to the tester as shown below.

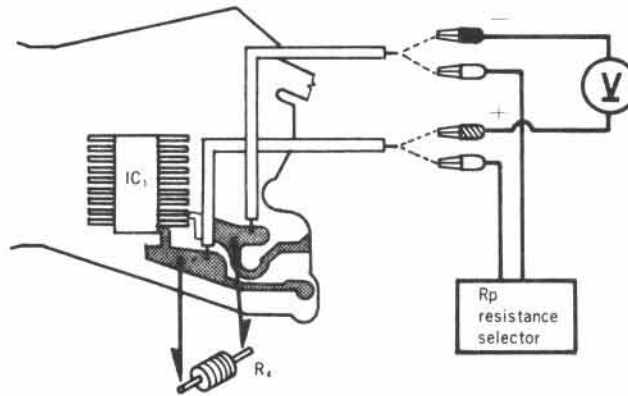

2. Turn ON the metering switch (S_1) and adjust the dial of Rp resistance selector so that the voltage indicated on the digital tester is the most approximate to 180 mV.
3. Select R_4 whose resistance is the most approximate to the value obtained by Rp resistance selector, and then solder it to the circuit board. Measure the voltage at either end of R_4 (disconnecting the Rp resistance selector), and make sure that the voltage is $180 \pm \frac{2}{4}$ mV.
 - If it is not within $180 \pm \frac{2}{4}$ mV, check again to decide whether to grade up or down the resistance of R_4 by one rank.

Increasing the resistance of R_4 increases voltage.

Decreasing the resistance of R_4 decreases voltage.

[Types of R_4]

Resistance value (K Ω)	Part No.	Resistance value (K Ω)	Part No.
20	9422-2036-32	39	9422-3936-32
22	9422-2236-32	47	9422-4736-32
24	9422-2436-32	56	9422-5636-32
27	9422-2736-32	68	9422-6836-32
30	9422-3036-32	100	9422-1046-32
33	9422-3336-32	200	9422-2046-32

104

3 Adjustment of EE

- Measuring instruments : Luminance box (MODEL L-2101, L-222, L-223)
 : EE tester (MODEL EE-2101, EE-2111)
 : Standard lens (50 mm/F 1.4)

■ Standard :

Allowable range of EE level	$0 \pm 0.8 \text{ EV}$
Variation of EE level	0.6 EV or less

■ Adjusting procedure

1. Set the measuring instruments as follows:

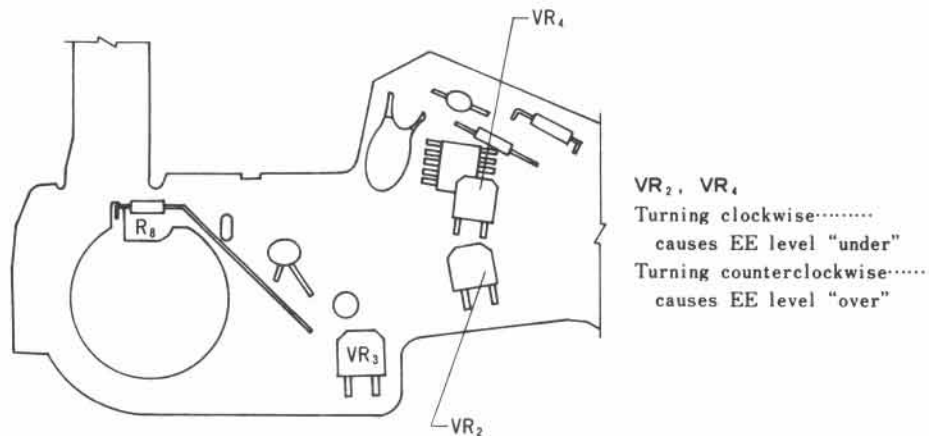
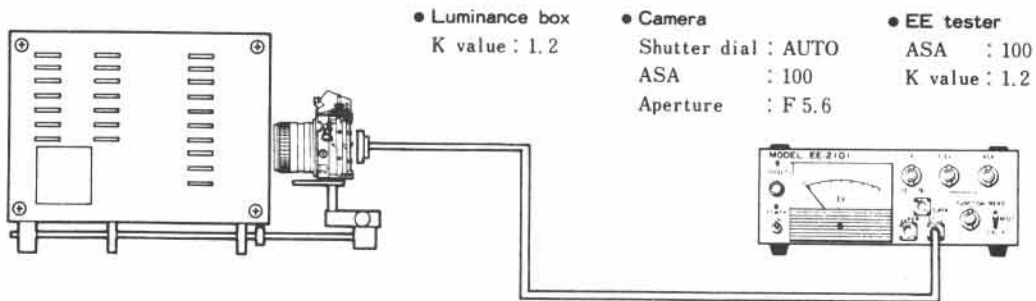

- Set the luminance box to EV 9. Release the shutter, adjust by turning VR₂ so that the EE level is within $0 \pm 0.8 \text{ EV}$.
- Next, set the luminance to EV 15, and adjust by turning VR₄ so that the EE level is within $0 \pm 0.8 \text{ EV}$.

Confirmation: Check the EE level at EV 9 and, if it is not within $0 \pm 0.8 \text{ EV}$, make the above-mentioned adjustments 2 and 3 again.

4 Adjustment of LED indication

- Measuring instruments : Luminance box (MODEL L-2101, L-222, L-223)
 : Standard lens (50 mm/F 1.4)

■ Standard

- (1) Luminance : EV 11 } Allowable positions of
 ASA : 100 } LED indication (± 1 EV)
 Aperture : F 8

	+ 1 EV	+0.5EV	0	-0.5EV	- 1 EV
60	☼	☼	●	●	●
30	●	☼	☼	☼	●
⋮	●	●	●	☼	☼

[Note] When only LED “:” is indicated, change the luminance to EV 12 (ASA 100) or the aperture to F 5.6, and check if LED “30” lights up.

- (2) Luminance : EV 14 } Allowable positions of
 ASA : 100 } indications (± 1 EV)
 Aperture : F 5.6

	+ 1 EV	+0.5EV	0	-0.5EV	- 1 EV
1000	☼	☼	●	●	●
500	●	☼	☼	☼	●
250	●	●	●	☼	☼

■ Adjusting procedure

1. Set the measuring instrument as follows:

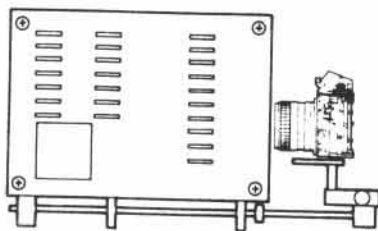

- Luminance box
K value : 1.2

- Camera
ASA : 100
Shutter dial : AUTO

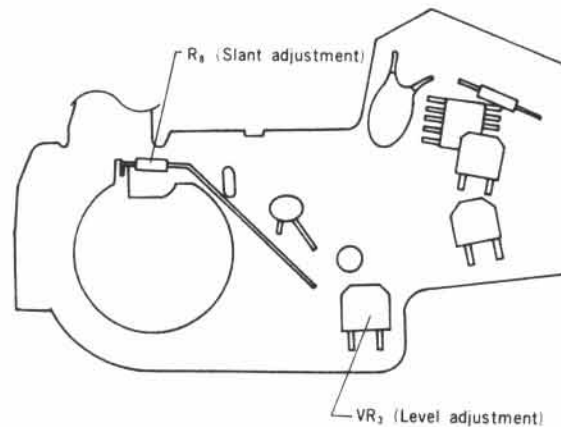

2. Adjust by turning VR_3 so that LED “30” lights up when measured with luminance at EV 11 and aperture at F 8. Turning VR_3 clockwise causes the indication to be shifted upward, and turning it counterclockwise causes the indication to be shifted downward.
3. Next, make sure that the LED of standard (2) lights up when measured with luminance at EV 14 and aperture at F 5.6. If an LED outside the allowable range is indicated, make the adjustment (of slant) as follows or turn VR_3 so that the standards (1) and (2) are satisfied.

■ Adjustment of slant

- When indicated LED is deflected toward the lower speed side than standard (2)
.....Change the resistor (R_8) to larger resistance.
- When indicated LED is deflected toward the higher speed side than standard (2)
.....Change the resistor (R_8) to smaller resistance. (※)
※ If changing R_8 is not enough, shortcircuit R_8 with lead wire.
- After the adjustment of slant, perform the adjustments 2 and 3 again.

106

■ Adjustment of X shutter speed

This adjustment should be performed after auto exposure adjustment. (Be sure to make this adjustment after replacement of R₄ or adjustment of EE.)

■ Measuring instrument : Shutter tester (MODEL S-2101, FS1D-MN4)

■ Standard :

Std value	Allowable range
16.7 ms	11.0~22.0 ms

■ Adjusting procedure

1. Release the shutter with the dial set to X, and adjust by turning VR₁ so that the shutter speed is in a range of 15.0 to 18.5 ms. Turning VR₁ clockwise decreases the shutter speed, and turning it counterclockwise increases it.

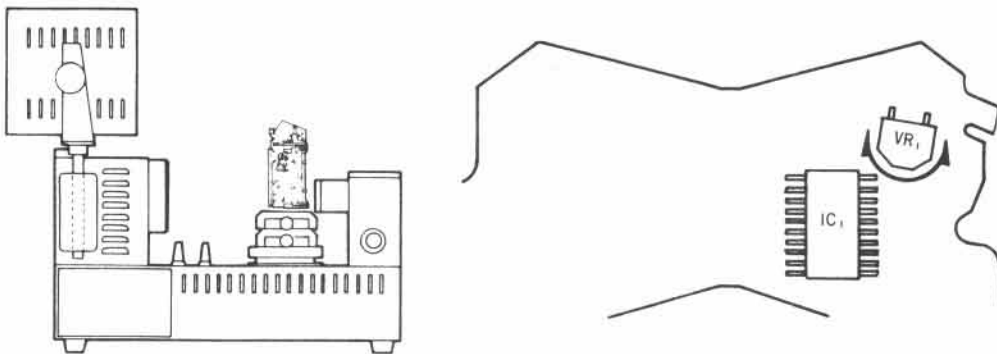

■ Check of synchro time lag

■ Measuring instrument : Shutter tester (MODEL S-2101, FS1D-MN4)

■ Standard :

Shutter dial	X
A range	0.3 ms or over
B range	2.0 ms or over

■ How to check

1. Set the measuring instrument as follows:

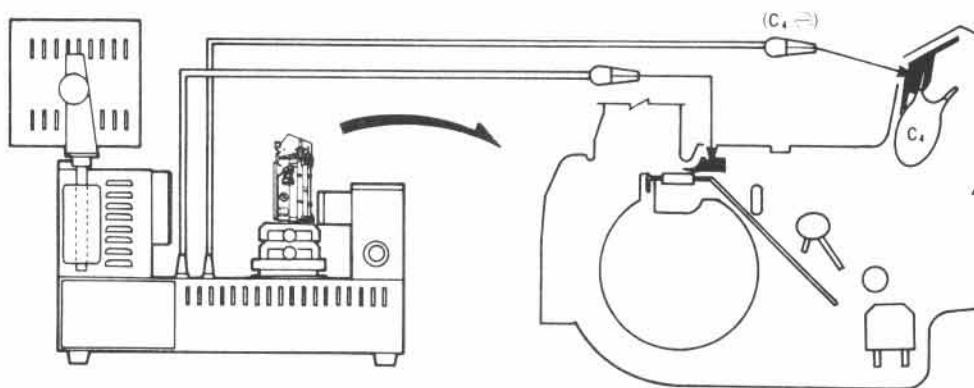

2. When the shutter is released with the dial set to X, the synchro time lag should be within the standard mentioned above.

● If not, make the adjustment on P. 14.

101

■ Check of high luminance non-interlock lock

■ Measuring instrument : Luminance box (MODEL L-2101, L-222, L-223)

■ Standard

- | | |
|-----------------------|---|
| (1) Luminance : EV 15 | } It should be unable to release with Δ (high luminance non-interlock) |
| ASA : 250 | |
| Aperture : F 5.6 | |
| (2) Luminance : EV 14 | } It should be able to release with Δ (high luminance non-interlock) |
| ASA : 125 | |
| Aperture : F 5.6 | |

■ How to check

1. Set the measuring instrument as follows:

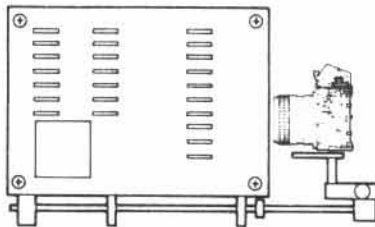

- Luminance box
K value : 1.2
- Camera
Shutter dial : AUTO
Aperture : F 5.6

2. ● When light is measured with luminance at EV 15 and camera's ASA at 250, the high luminance warning (Δ) should turn ON and it should be unable to release the shutter.
- When light is measured with luminance at EV 14 and ASA at 125, the high luminance warning (Δ) should turn OFF and it should be able to release the shutter.
3. If the standard is not satisfied, re-adjust the LED indication (P.7).

108

■ Check of flash function

1 Check before completion

■ Measuring instrument : Constant voltage D.C power supply (MODEL 524B, E-1, E-2)

■ Standard :

Voltage (V)	Indication in viewfinder	Release the shutter
0	Auto speed	Runs according to the auto speed
1.6	OFF	Fully opens and 2nd curtain runs with power OFF
2.0	"60" LED ON	Fully opens and 2nd curtain runs with power OFF

■ How to check

1. Connect the power source as shown below. (Connect 300 ohm resistor to the positive side.)

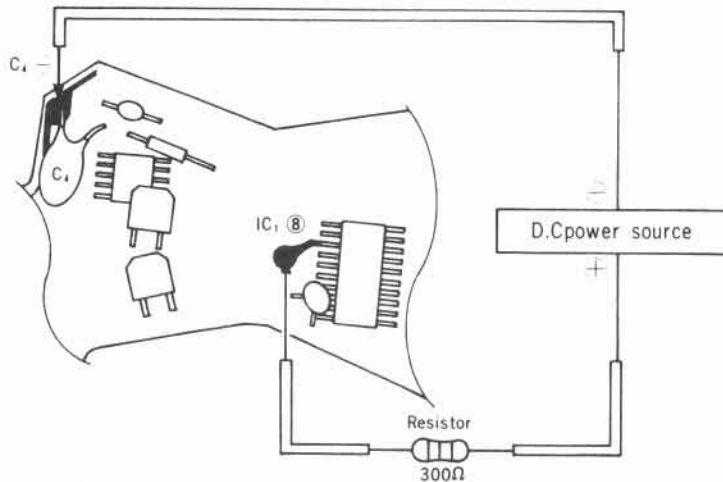

2. Set the shutter dial to AUTO, change the supply voltage to 1.6 V and 2.0 V, then check the indication in viewfinder and the shutter operation to see if they are as specified.
 - If the standard is not satisfied, refer to the trouble shooting chart (P.11) of Service Manual for 2006.

2 Check after completion

■ Measuring instruments : Shutter tester (MODEL S-2101, FS1D-MN4)
: Flash (Auto Electroflash 200X...Code No.8668)

■ Standard

With flash charge completed, the "60" LED should blink, and the shutter speed should be shifted to 17~23 ms.

■ How to check

1. Set the flash (8668) on the camera, set the shutter dial to AUTO, and metering switch to ON. Then charge the flash and check the alteration of LED indication in viewfinder.
 - During charge, the auto shutter speed should be indicated and on completion of charge the "60" LED should blink with other indications turned OFF.
2. With the shutter dial set to AUTO, when the shutter is released after completion of flash charge, the shutter speed should be within a range of 17~23 ms.

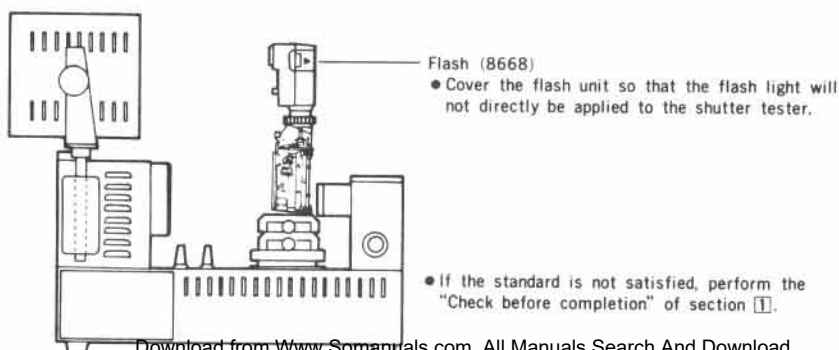

■ Check and adjustment of shutter block

- **Measuring instruments** : Camera standard tester (MODEL ST-5101)
 : Temporary body (2006-0101-75)---Not required when checked with body completed.

■ **Preparations**

1. Check before building it into body.
 - ① Shift the take-up shaft bearing (0310) of temporary body (2006-0101-75) in the direction of the arrow, and set the eccentric screw (9281) of shutter charge gear D (0350) to the position of Fig.1.
 - ② Attach the shutter block to the front base plate of the temporary body, and shift the front base plate to the winding side of the body to set it up.
 - ③ Shift the take-up shaft bearing (0310) so that the (-) mark of charge gear A (2105) matches the crest of shutter charge gear C (3016) as in Fig.2, and then tighten the screw.
 - ④ Slowly wind and adjust by eccentric screw (9281) so that winding is completed with sprocket idle gear (3034) and is over-charged by one tooth from the control base plate (0211) when the 2nd curtain stop lever (0229) greatly moves in the direction of the arrow (where the shutter charge is completed).

■ Fig. 1

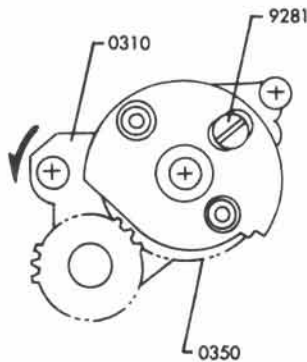

■ Fig. 2

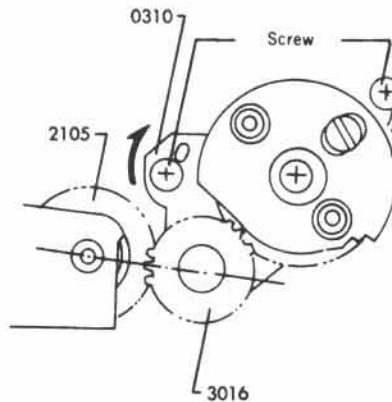

■ Fig. 3

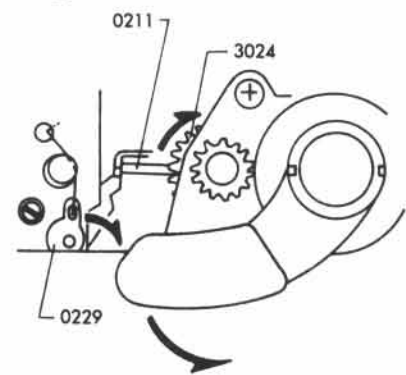

- ⑤ Connect the shutter block leads to the tester as shown below.

■ Fig. 4

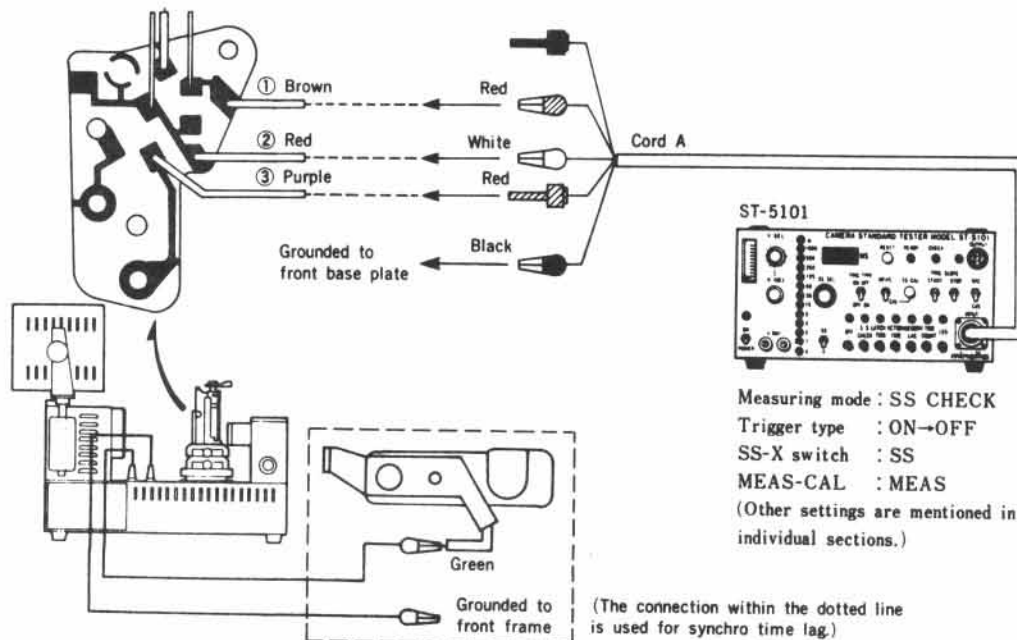

2. Check with body completed

① Remove the top cover, and connect the leads from shutter block to the tester as shown below.

- Unsolder the shutter block leads ①~③ (Fig. 4 of P. 11) and connect them to the tester (ST-5101).

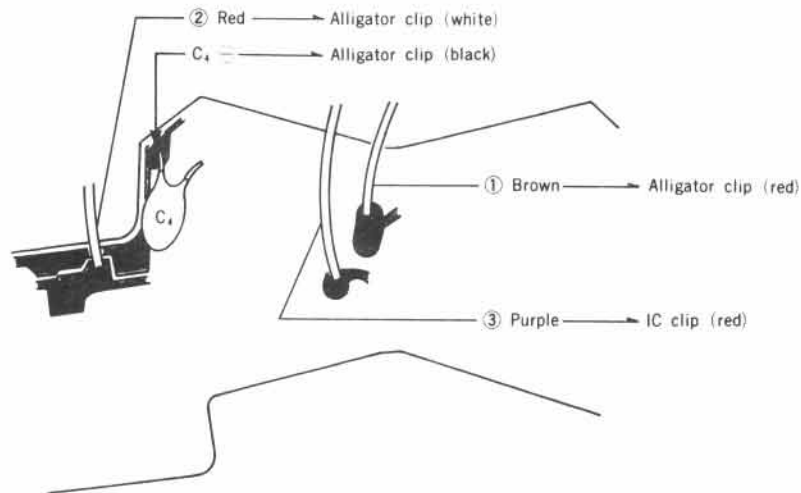

② Set the shutter dial to B or X. (Release lock works in AUTO mode.)

1 Check of magnet attraction

■ Standard : It should not cause failure of exposure at 1.5V.

■ How to check

1. When shutter is released with V-SEL switch of ST-5101 set at 1.5V and SS-SEL switch at 1 (sec.), shutter should not cause failure of exposure.

- If exposure failure takes place, check for stains, scratches, etc. on the magnet surface.

2 Check of curtain speed

■ Standard : 10.8~11.2 ms (both 1st & 2nd curtains)

■ How to check

1. When shutter is released with V-SEL switch of ST-5101 set at 2.8V and SS-SEL switch at 1000, the curtain speed should be within the standard.

- If the standard is not satisfied, adjust it by ratchet (2147). (When checking with body completed, remove the battery case base plate.)

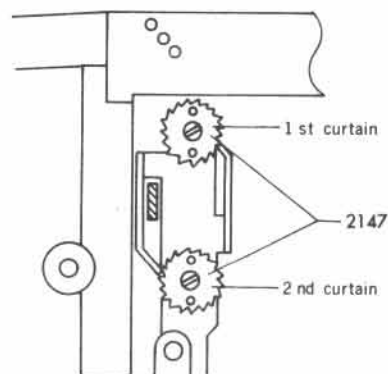

3 Check of manual second

■ Standard :

Shutter speed	Std value	Allowable range
1/1000	0.98 ms	0.7~1.34 ms
1/30	31.3 ms	26.3~37.2 ms
1/1	1000 ms	841~1190 ms

■ How to check

1. Check the shutter speed with V-SEL switch of ST-5101 set at 2.8V, and SS-SEL switch to 1000, 30, 1.
 - If the standard is not satisfied, adjust by turning the eccentric pin of S_3 .

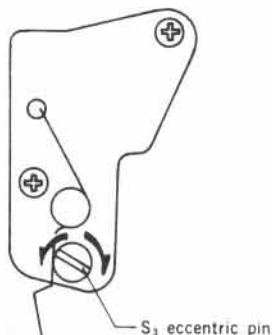

4 Check of minimum operation voltage

■ Standard : Difference in speed for 1/1000 between supply voltage 2.8V and 1.85V should be within 0.4 ms.

■ How to check

1. Check the speed with SS-SEL switch of ST-5101 set at 1000, and V-SEL switch to 2.8V, 1.85V.
 - If the standard is not satisfied, check the attraction of the magnet as in Sec. 1.

5 Check of curtain bound

■ Standard : There should no bound within the image plane.

■ How to check

1. Release the shutter with V-SEL switch of ST-5101 set at 2.8V and SS-SEL switch at 125, and check for bound through the indicator lamp of shutter tester.
 - If bounding takes place, remove the shutter cover plate (0218) and check for deformation of the brake spring.

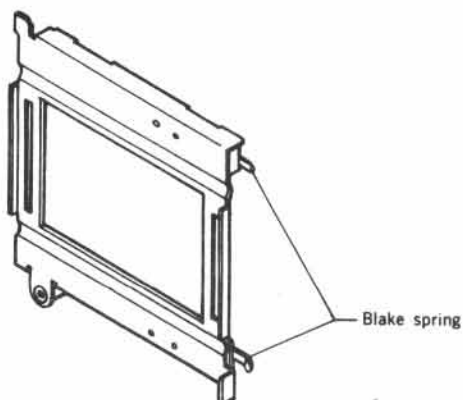

6 Check of synchro time lag

■ Standard :

Shutter speed	1/60
A range	0.3 ms or over
B range	2.0 ms or over

■ How to check

1. Connect the X contact lead (green) to the shutter tester. (Fig.4 of P.11)
 - When checked with body completed, use a hot shoe jig or remove the top cover and follow the procedure of P.8.
2. Release the shutter with V-SEL switch of ST-5101 set at 2.8V and SS-SEL switch at 60, then check the values of A and B ranges.
 - If the standard is not satisfied, adjust by turning the X lever stopper.

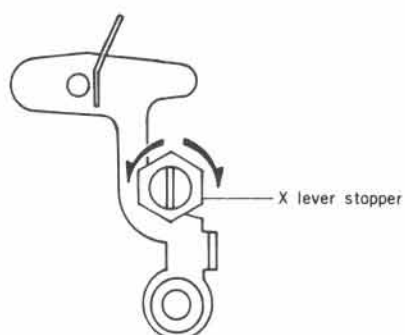

■ Measuring instruments

- Standard luminance box (Model L-2101, *L-222, *L-223)
 - EE tester (Model EE-2101, EE-2111)
 - SS adaptor for EE tester (Model SD-2101)
 - Shutter tester (Model S-2101, *FS1D-MN4)
 - Time counter (Model TC-1)
 - Digital multimeter (Model 2508, *3476, *2507)
 - Camera standard tester (Model ST-5101)
 - Constant voltage D.C power supply (Model 524B, *E-1, *E-2)
 - Mirror angle adjuster (Model MA-III, *II)
 - Rp resistance selector (Model RS-VI, *III, *II, *I)
 - 1000 mm collimator (Model RC-1000 III, *II, *I)
- (Items marked "※" have been discontinued)

■ Tools used in common

- | | | |
|--|--|---|
| <ul style="list-style-type: none"> ■ Tool No. 2006-0101-75
Temporary body ■ Tool No. 2006-0415-75
Battery adapter ■ Tool No. 2006-2020-75
Shutter button pressure spanner ■ Tool No. 2006-2291-75
Sync. terminal spanner | <ul style="list-style-type: none"> ■ Tool No. 2006-3003-75
Winding lever pressure ■ Tool No. 2006-3013-75
Top cover set nut B spanner ■ Tool No. 2006-3309-75
Temporary nut ■ Tool No. 2006-3310-75
Top cover pressure nut spanner | <ul style="list-style-type: none"> ■ Tool No. 054-5202-79
Master lens for 054 finder back adjustment ■ Flat plate (for 2005) ■ Body back gauge (43.70 mm) ■ Dial gauge |
|--|--|---|

■ Sub materials

- | | | | |
|--|---|--|---|
| <ul style="list-style-type: none"> ■ Grease ● # 3340 ● # 335 ● # 1150D ● LOSIMOL ELT-BAE | <ul style="list-style-type: none"> ■ Oil ● # 012 | <ul style="list-style-type: none"> ■ Adhesives ● BOND G 17 ● 3-BOND 1401B
{for screw lock} ● LOCTITE #242 ● SILICON BOND KE-441RTV | <ul style="list-style-type: none"> ■ Cleaner ● FLONSOLVE |
|--|---|--|---|

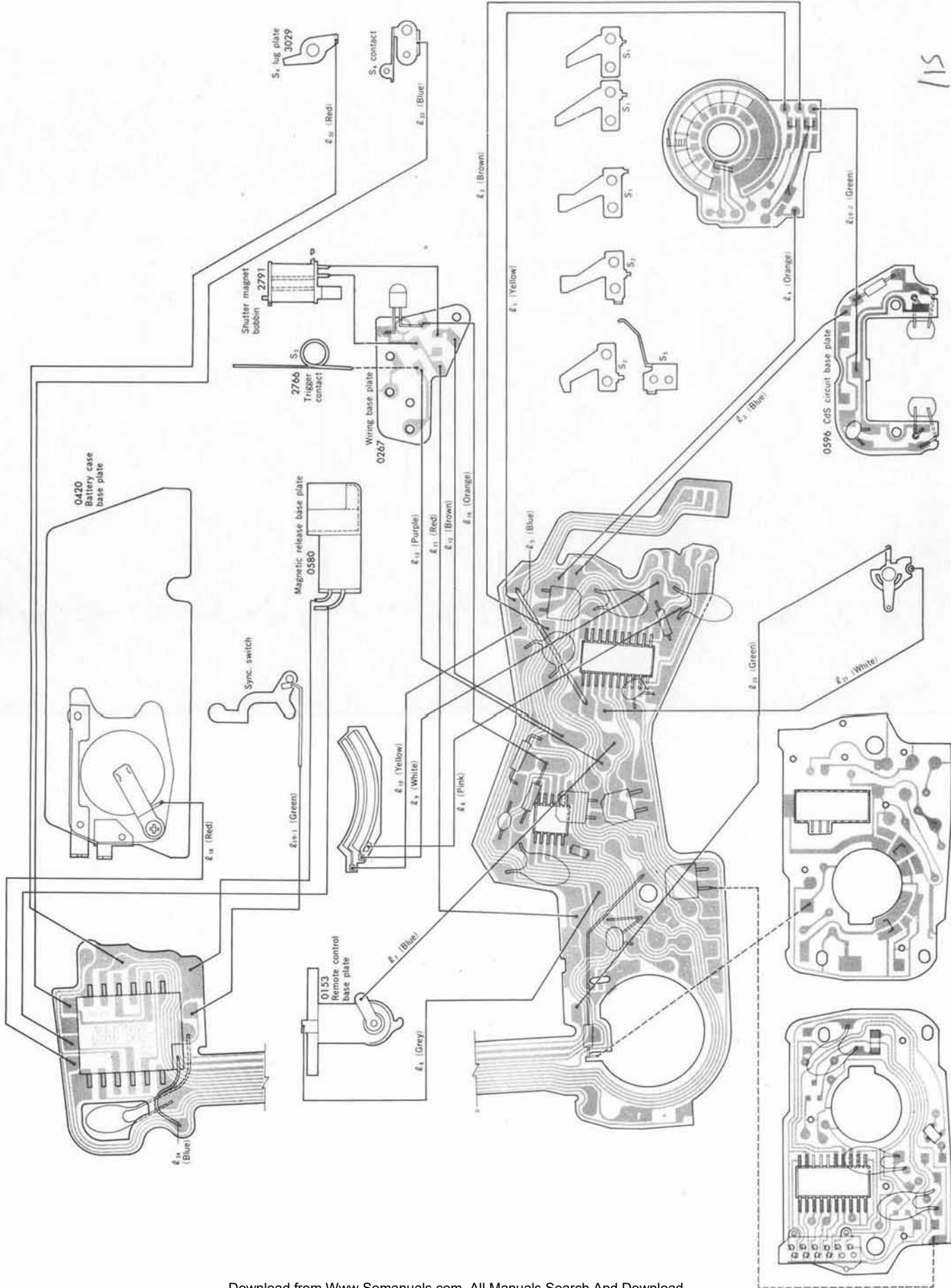

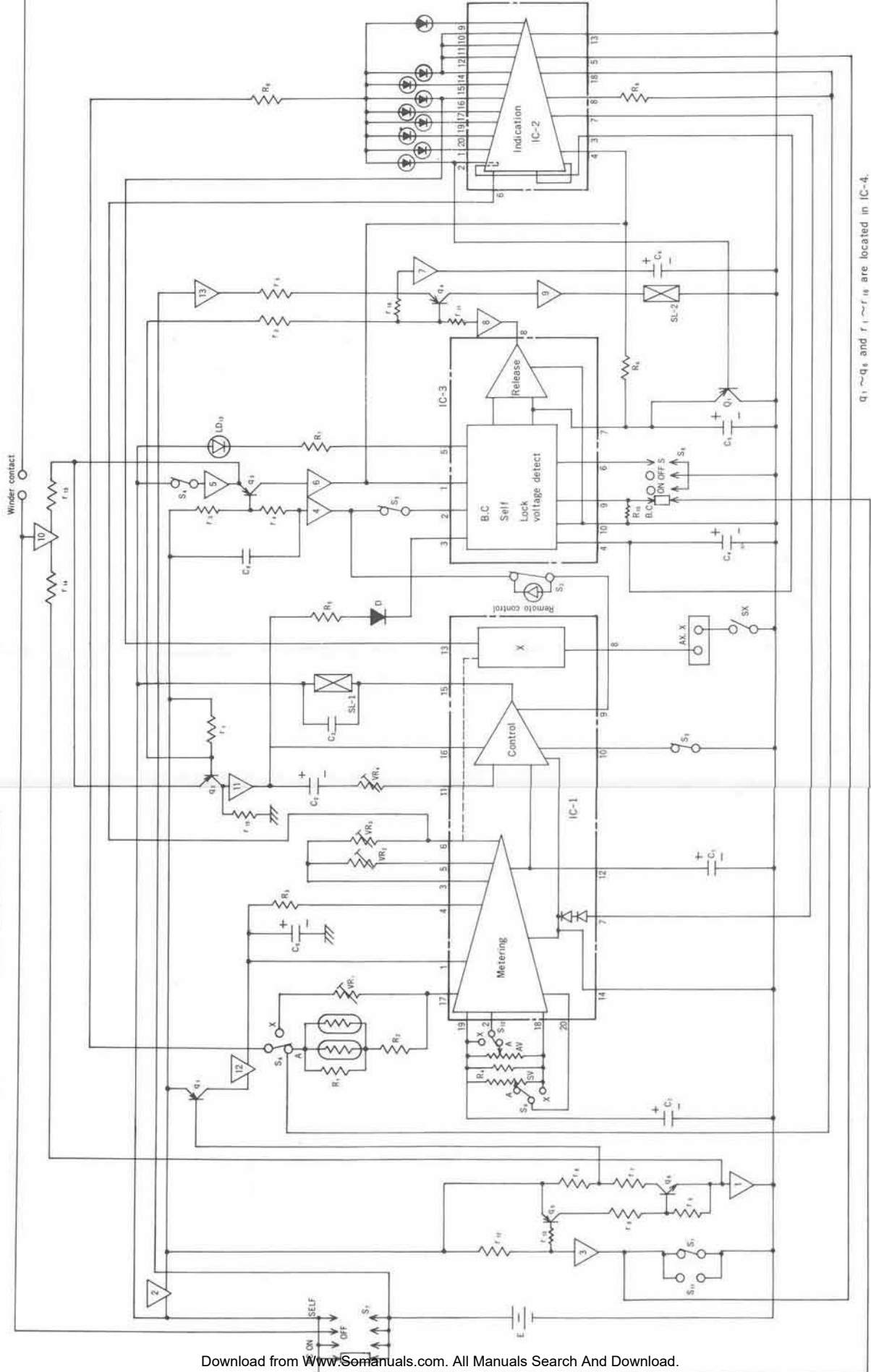

XG-A CIRCUIT DIAGRAM (2013-300)







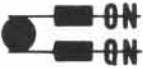
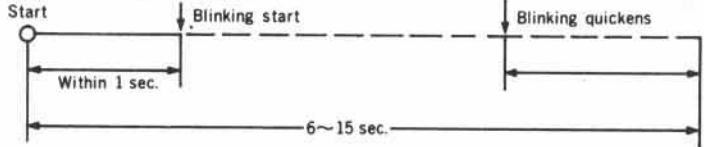

q₁ ~ q₈ and r₁ ~ r₁₄ are located in IC-4.
q₁ ~ q₈, r₁ ~ r₁₄ は IC-4内です。

Inspection Standard

1. This standard specifies uniform performance levels for servicing in order to guarantee our product's quality to customers. Each item is detailed so that you can follow this standard when you receive inquiries from users or are asked for checks.
2. When delivery or acceptance inspections are required, do not directly apply this standard to the performance measurements, but refer to the corresponding standard (manul).
3. Some users, because of their taste or special purposes, may require adjustment of this standard. In this case, perform the adjustment according to the user's request whenever possible.

Check Item	Check point	Description
Winding	Winding lever	Not smooth (uneven, catching), shifted back, noise, vertically loose. Winding torque...less than 4 kg·cm (with film).
	Spool	Operation...Not smooth (uneven, squeaky). Check film winding. No-load operation...250±50 g.
	Sprocket	Operation...Slip, back lash (after winding). Operation with rewind button depressed (uneven, catching). Claw position.
Rewinding	Rewind button	Operation...Depressing, releasing, catching, uneven. Rewind button lock position...over 0.3 mm (from bottom of lower cover).
	Rewind crank	Operation...Off-center, squeaky, gritty, defective spring. Film rewinding resistance...250~650 g.
Film counter	Feed	Operation...When wound twice from S, indication should be 1. It should correctly operate up to 36+1. Check for failure, standstill, skip, deflection. Deflection of scale position...Center of letter should be within the range of index. Scale letter should be easy to read. 
	Return	Operation...It should return to S when back cover is opened.
Film signal	Appearance	Operation...Signal should be as illustrated at the 1st frame on counter, midway, 36+2 frames. Check for unsmooth operation (catching, etc). 
	Disappearance	Operation...Signal should disappear just before film is disengaged from spool in rewinding.
Shutter	Shutter button	Operation...Not smooth, loose, catching, shock, stained, wrong position. Operating-resistance...250±50 g. After-operation allowance...over 0.2 mm
	Dial	Operation...Not smooth, clicking, auto lock, loose. Auto lock...Loose, squeaky, gritty, etc. Scale deflection...Center of letter should be aligned to index. 

Check Item	Check point	Description																		
Shutter	Shutter curtain	Operation...Overlap, return (during little-by-little winding), bound, 2 nd curtain appearance (in slow shutter), bump, stop, noise. Curtain speed...Within 13 ms for both 1 st and 2 nd curtains.																		
	X shutter speed	11.0~22.1 ms.																		
	Synchro	Conduction...Light emission, No shorting during winding. Delay time <table border="1"> <thead> <tr> <th>Contact</th> <th>Shutter speed</th> <th>Measurement</th> <th>Standard</th> </tr> </thead> <tbody> <tr> <td rowspan="2">X</td> <td rowspan="2">X & X speed auto setting</td> <td>Time until contact is ON after curtain running. (A range)</td> <td>over 0.3 ms</td> </tr> <tr> <td>Time until curtain appearance after contact is ON. (B range)</td> <td>over 2 ms</td> </tr> </tbody> </table> Contact efficiency <table border="1"> <thead> <tr> <th>Contact</th> <th>Measuring time</th> <th>Shutter speed</th> <th>Standard</th> </tr> </thead> <tbody> <tr> <td>X</td> <td>1.0 ms</td> <td>X & X speed auto setting</td> <td>over 60%</td> </tr> </tbody> </table> Insulation resistance...over 10MΩ (250 V D.C resistance meter)	Contact	Shutter speed	Measurement	Standard	X	X & X speed auto setting	Time until contact is ON after curtain running. (A range)	over 0.3 ms	Time until curtain appearance after contact is ON. (B range)	over 2 ms	Contact	Measuring time	Shutter speed	Standard	X	1.0 ms	X & X speed auto setting	over 60%
	Contact	Shutter speed	Measurement	Standard																
X	X & X speed auto setting	Time until contact is ON after curtain running. (A range)	over 0.3 ms																	
		Time until curtain appearance after contact is ON. (B range)	over 2 ms																	
Contact	Measuring time	Shutter speed	Standard																	
X	1.0 ms	X & X speed auto setting	over 60%																	
Operating	Lever	Operation...Clicking, deflection, return, not smooth, catching, defective spring. Return to ON position after B.C check, return to click position from lever contact position self side. Letter indication should be aligned to lever index. 																		
	Self-timer	Operation...Lamp should start blinking within 1 sec. after S button release, and blinking cycle should become faster just before release. Alteration of blinking cycle: 																		
	Battery Checker	Operation...Lamp should be lighted exactly. Lamp should be on in the range from 1/2 or over to B.C contact. 																		
Focus	Mirror	Operation...Loose, two-step, timing, wrong position, bound. Stop position...45° ± 30° Raising position...It should be unseen behind flare preventing board.																		
	Body back	43.70 ± 0.01 mm																		
	Finder back	43.56 ± 0.025 mm																		
Finder	View	Image turnover, ∞ matching, scale plate deflection.																		
	Speed figure band	Scratches, dust, stains, etc. Figure and LED should be positioned within figure band. 																		

Check Item	Check point	Description																																																						
Back cover	Opening Closing	Operation...Locking, looseness after locking. It should smoothly release when rewinding knob is shifted up.																																																						
	Pressure plate	Distortion, projection, irregular surfaces, impurities, stains, inclining, easy to come loose.																																																						
Auto exposure	ASA dial	Operation...Not smooth, catching, deflecting. For ASA letter, scale and frame, the 3rd scale should be visible. 																																																						
	Over range release lock	LENS : 50 mm F 1.4 <table border="1" data-bbox="597 695 1360 802"> <thead> <tr> <th>Luminance</th> <th>ASA</th> <th>Aperture</th> <th>Shutter release</th> </tr> </thead> <tbody> <tr> <td>EV 15</td> <td>250</td> <td>F 5.6</td> <td>Release lock should work.</td> </tr> <tr> <td>EV 14</td> <td>125</td> <td>F 5.6</td> <td>Release should work.</td> </tr> </tbody> </table> <p>It should be exactly locked with 1000  or 1000  LED lamp lighted.</p>	Luminance	ASA	Aperture	Shutter release	EV 15	250	F 5.6	Release lock should work.	EV 14	125	F 5.6	Release should work.																																										
	Luminance	ASA	Aperture	Shutter release																																																				
	EV 15	250	F 5.6	Release lock should work.																																																				
	EV 14	125	F 5.6	Release should work.																																																				
LED indication	Scratches, dust, cloud, light leakage (with dark finder) LED difference...LENS: 50 mm F 1.4 ASA: 100, Auto <table border="1" data-bbox="597 972 1360 1255"> <thead> <tr> <th rowspan="2">Luminance</th> <th rowspan="2">Aperture</th> <th rowspan="2">Correct LED</th> <th colspan="5">Allowable range</th> </tr> <tr> <th>+ 1</th> <th>+0.5</th> <th>0</th> <th>-0.5</th> <th>- 1</th> </tr> </thead> <tbody> <tr> <td rowspan="3">EV 14</td> <td rowspan="3">F 5.6</td> <td rowspan="3">500</td> <td>1000</td> <td></td> <td></td> <td></td> <td></td> <td></td> </tr> <tr> <td>500</td> <td></td> <td></td> <td></td> <td></td> <td></td> </tr> <tr> <td>250</td> <td></td> <td></td> <td></td> <td></td> <td></td> </tr> <tr> <td rowspan="3">EV 11</td> <td rowspan="3">F 8</td> <td rowspan="3">30</td> <td>60</td> <td></td> <td></td> <td></td> <td></td> <td></td> </tr> <tr> <td>30</td> <td></td> <td></td> <td></td> <td></td> <td></td> </tr> <tr> <td>∴</td> <td></td> <td></td> <td></td> <td></td> <td></td> </tr> </tbody> </table> <p>LED other than correct LED and adjacent LED should not be lighted. LED lighting voltage...2.0 V (in darkness).</p>	Luminance	Aperture	Correct LED	Allowable range					+ 1	+0.5	0	-0.5	- 1	EV 14	F 5.6	500	1000						500						250						EV 11	F 8	30	60						30						∴					
Luminance	Aperture				Correct LED	Allowable range																																																		
		+ 1	+0.5	0		-0.5	- 1																																																	
EV 14	F 5.6	500	1000																																																					
			500																																																					
			250																																																					
EV 11	F 8	30	60																																																					
			30																																																					
			∴																																																					
Exposure correction	Operation...Not smooth, clicking, lock release.																																																							
Exposure error	LENS : 50 mm F 1.4, ASA : 100 <table border="1" data-bbox="597 1480 1360 1623"> <thead> <tr> <th>Luminance</th> <th>Aperture</th> <th>EE level allowable range</th> <th>Variation</th> </tr> </thead> <tbody> <tr> <td>EV 15</td> <td>F 5.6</td> <td rowspan="3">Within±0.8 EV</td> <td rowspan="3">Within±0.6 EV</td> </tr> <tr> <td>EV 14</td> <td>F 5.6</td> </tr> <tr> <td>EV 9</td> <td>F 5.6</td> </tr> </tbody> </table>	Luminance	Aperture	EE level allowable range	Variation	EV 15	F 5.6	Within±0.8 EV	Within±0.6 EV	EV 14	F 5.6	EV 9	F 5.6																																											
Luminance	Aperture	EE level allowable range	Variation																																																					
EV 15	F 5.6	Within±0.8 EV	Within±0.6 EV																																																					
EV 14	F 5.6																																																							
EV 9	F 5.6																																																							
Other performance	Checker voltage	Room temperature: 25°C <ul style="list-style-type: none"> ● It should light up at 2.15 V. ● It should not light up at 1.85 V. 																																																						
	Touch switch operating resistance	<ul style="list-style-type: none"> ● LED indication is on with 10MΩ, and off with 30 MΩ. 																																																						

119

Check Item	Check point	Description										
Other performance	Release lock minimum voltage	<ul style="list-style-type: none"> ● Release lock should work at 1.75 V. ● Release should work at 2.15 V. 										
	Performance assuring voltage	2.15~3.0 V (D.C power supply: 2.25~2.8 V)										
	Current consumption	(D.C power supply: 2.8 V) <table border="1" style="margin-left: 20px;"> <thead> <tr> <th>Item</th> <th>Standard</th> </tr> </thead> <tbody> <tr> <td>B.C lighted</td> <td>35mA max.</td> </tr> <tr> <td>• LED 1 lamp 2 lamps</td> <td>10mA max.</td> </tr> <tr> <td>• Metering</td> <td></td> </tr> <tr> <td>Releasing</td> <td>30 mA max.</td> </tr> </tbody> </table>	Item	Standard	B.C lighted	35mA max.	• LED 1 lamp 2 lamps	10mA max.	• Metering		Releasing	30 mA max.
	Item	Standard										
B.C lighted	35mA max.											
• LED 1 lamp 2 lamps	10mA max.											
• Metering												
Releasing	30 mA max.											
Leak current	Less than 5 μ A (D.C power supply: 2.8 V)											
Accessories	Accessory	Looseness, spring pressure, removal, inclining.										
	Remote control terminal	Operation...It should be easy to detach. Looseness, heavy, release, catching. Cable release switch operation...70~300 g.										
	Eye-piece attachment	Clicking, easy to come loose, inclined.										
	Lens lock	Operation...Heavy, light, gritty, squeaky, loose.										
Others	Interchanges ability with exclusive flash	LED 60 blinking with exclusive flash charge completed. Synchronising...With charge completed, it should be tuned irrespective of shutter dial position.										
	Interchangeability with winder	Winder connecting terminal voltage <ul style="list-style-type: none"> ● Winding completed (S₄ ON)...over 1.0 V. ● Releasing completed (S₄ OFF)...below 0.2 V. 										

120

Free Manuals Download Website

<http://myh66.com>

<http://usermanuals.us>

<http://www.somanuals.com>

<http://www.4manuals.cc>

<http://www.manual-lib.com>

<http://www.404manual.com>

<http://www.luxmanual.com>

<http://aubethermostatmanual.com>

Golf course search by state

<http://golfingnear.com>

Email search by domain

<http://emailbydomain.com>

Auto manuals search

<http://auto.somanuals.com>

TV manuals search

<http://tv.somanuals.com>