

Service Manual

Cordless Rotary Hammer
EY6808

<Specifications>

HAMMER

Motor voltage	: 12V DC
Revolutions	: 0 ~ 780 min ⁻¹ (RPM)
Blows	: 0 ~ 3,500 min ⁻¹ (BPM)
Mass	: 2.8kg, 6.2lbs. including battery pack and auxiliary handle
Dimensions	: 277(L) × 85(W) × 190(H) mm 10-29/32" × 3-11/32" × 7-31/64" in

BATTERY PACK

Storage battery	: Ni-Cd battery
Battery voltage	: 12V DC (1.2V × 10 cells)

BATTERY CHARGER

Input	: 120V AC
Mass (Weight)	: 0.66kg, 1.45lbs.

<Standard equipment>

- Battery charger
- Battery pack

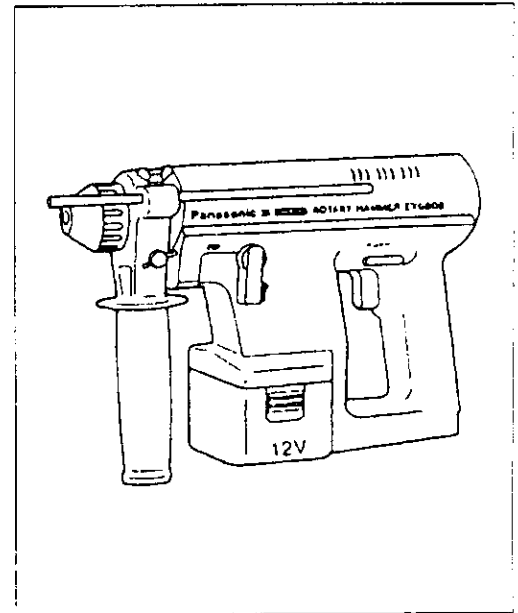

SCHEMATIC DIAGRAM

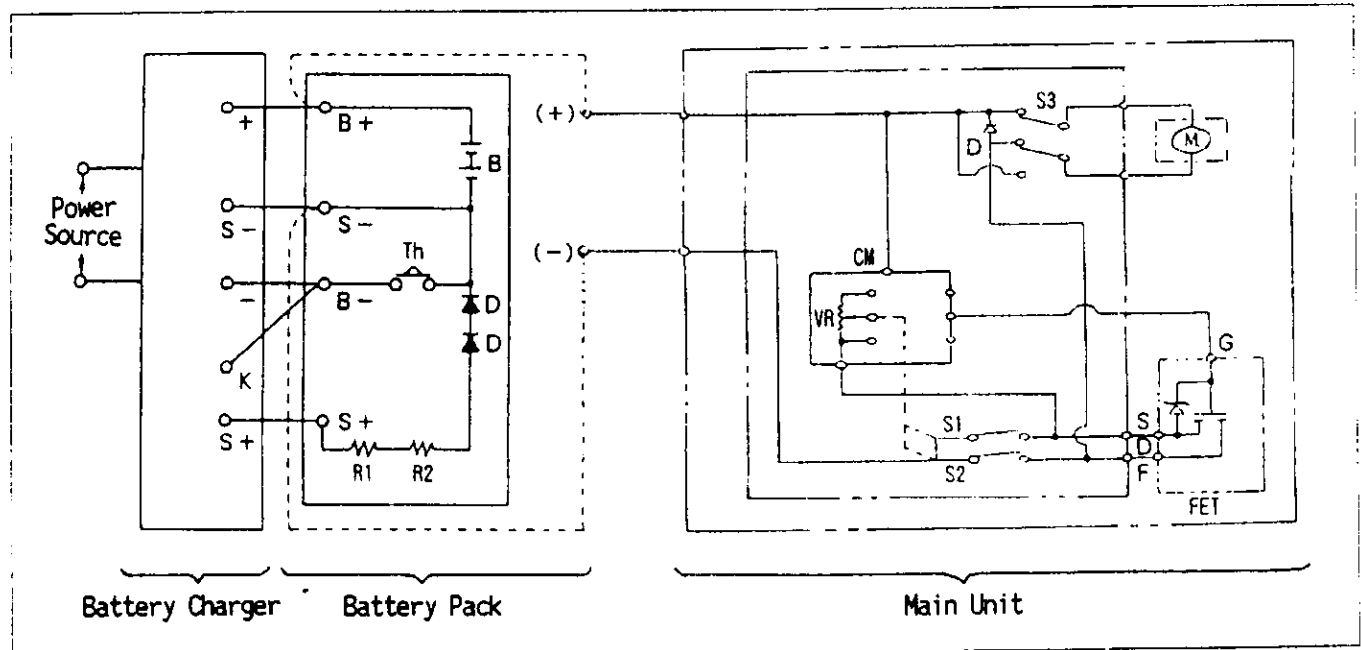

© 1996 Matsushita Electric Works, Ltd.
All rights reserved. Unauthorized copyin
and distribution is a violation of law.

Panasonic

⚠ WARNING

This service information is designed for experienced repair technicians only and is not designed for use by the general public. It does not contain warnings or cautions to advise non-technical individuals of potential dangers in attempting to service a product. Products powered by electricity should be serviced or repaired only by experienced professional technicians. Any attempt to service or repair the product or products dealt with in this service information by anyone else could result in serious injury or death.

EXPLODED VIEW

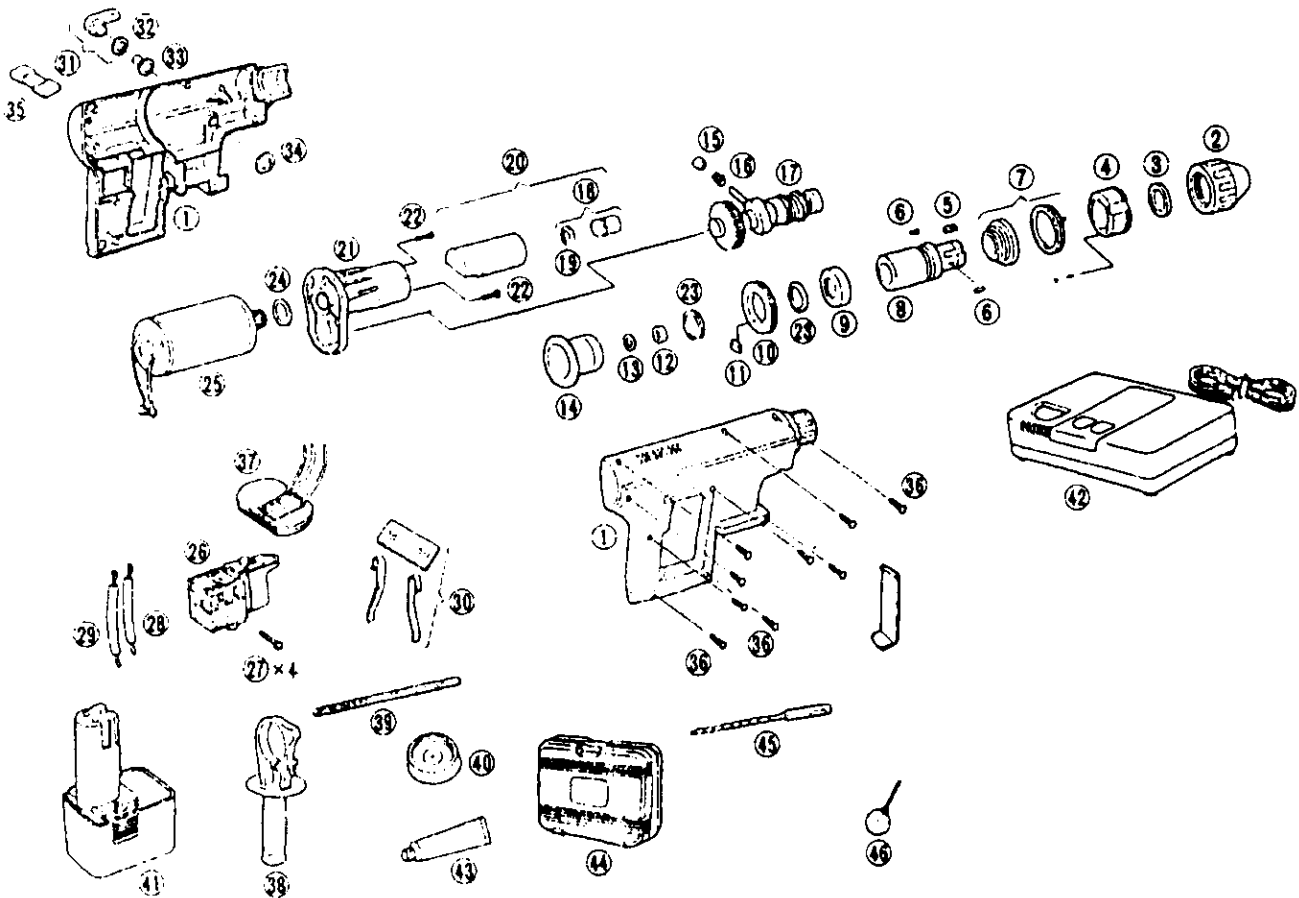

REPLACEMENT PARTS LIST

Ref No.	Parts No.	Parts Name & Descriptions	Per set	Remarks
Note :		*A ... available as an optional accessory	*C ... available individually	
		*B ... only available as set		
1	EY6808K3079	HOUSING AB SET	1	
2	EY6802H3117	CHUCK COVER	1	
3	EY6800B0417	STOP RING	2	*C ICTW-20
4	EY6802K1377	CHUCK CAM	1	
5	EY6802K1387	CHUCK KEY	1	
6	EY531B0477	TRANSMISSION KEY	2	*C
7	EY6802K0687	CHUCK RING	1	
8	EY6800B1127	OUTPUT SHAFT BLOCK	1	
9	EY6800B4957	NEEDLE BEARING	1	
10	EY6800B1357	SPINDLE GEAR	1	
11	EY6800B1387	SPINDLE GEAR KEY	1	
12	EY6800B3537	STRIKER WASHER	1	
13	EY6800B0997	STRIKER CUSHION	1	
14	EY6800B0577	CLUTCH BUSH	1	
15	EY6800B1517	UNIVERSAL JOINT	1	
16	EY6800B0177	SPRING FOR UNIVERSAL JOINT	1	
17	EY6800B1137	INTERMEDIATE SHAFT	1	
18	EY6800B4627	HAMMER	1	
19	EY6800B0977	O-RING	1	
20	EY6800B1247	PISTON HAMMER BLOCK	1	
21	EY6800B4737	BASE PLATE	1	
22	EY6800B6057	SCREW FOR BASE PLATE	2	*C K4-16
23	EY6800B0437	STOP RING	2	*C ISTW-30
24	EY6800B0987	O-RING FOR MOTOR	1	
25	EY6808L1008	MOTOR	1	
26	EY6261Y2008	SWITCH	1	
27	EY6207Y6027	SCREW FOR SWITCH	4	
28	EY6802L2967	LEAD WIRE (+)	1	*C K3-5
29	EY6802L2977	LEAD WIRE (-)	1	WHITE
30	EY6802K0067	BATTERY CONTACTOR SET	1	BLUE
31	EY6800H3248	HAMMER/DRILL SELECTOR HANDLE	1	
32	EY6800B0967	O-RING FOR SELECTOR HANDLE	1	
33	EY6800B0837	SWITCHING COLLAR	1	
34	EY6800B0447	STOP RING	1	STW-13
35	EY574H3248	FORWARD/REVERSE SELECTOR HANDLE	1	
36	EY6800B9447	HOUSING SCREW	8	*C K4-20
37	EY6808L2108	FET CIRCUIT BOARD	1	
38	EY6810H3237	SUPPORTER	1	
39	EY6810B7728	DEPTH GAUGE	1	
40	EY6808K0178	DUST PROOF PLATE	1	
41	EY9101	BATTERY PACK	1	*A
42	EY0202	BATTERY CHARGER	1	*A
43	EY6800B7919	GREASE	1	
44	EY9509	TOOL CASE	1	
45	EY531B7927	BIT	1	ø6.5
46	EY531B7767	SQUIRT	1	
-	EY6808K8238	SAFETY INSTRUCTIONS	1	
-	EY6808K8110	OPERATING INSTRUCTIONS	1	

WIRING CONNECTION DIAGRAM

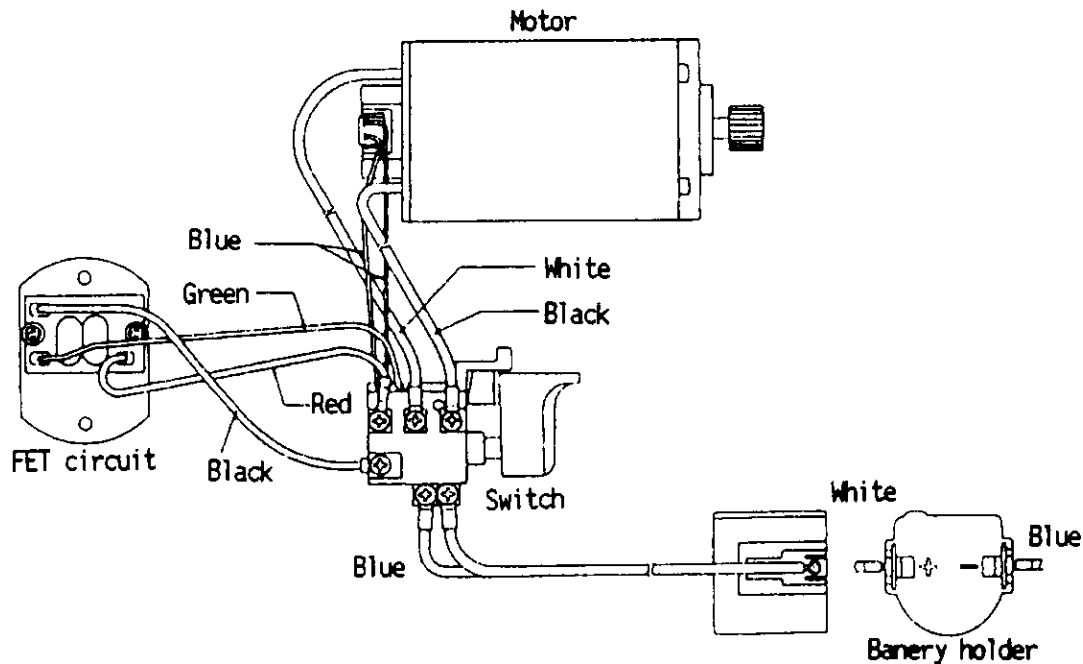

TROUBLESHOOTING GUIDE (Refer to WIRING CONNECTION DIAGRAM)

< TROUBLE >	< CHECK >	< REMEDY >
Does not operate.	<p align="center"><CHECK BATTERY PACK.></p> <p>If 12V DC is available across the (+) and (-) terminals, the battery pack is OK.</p> <p>Note: The battery pack is sold separately as shown in REPLACEMENT PARTS LIST. The battery pack has a limited life. The pack should be replaced if</p> <ul style="list-style-type: none"> - after being charged for the rated charging time the battery voltage is less than 12V DC or the usable time is extremely short. - the battery leaks. Check battery for leaks and corrosion terminals. 	NO Replace battery pack.
	OK	
	<p align="center"><CHECK TERMINAL CONNECTIONS BETWEEN MAIN UNIT AND BATTERY PACK.></p> <p>Check for proper terminal contacts.</p>	NO Repair the contacts.
	OK	
	<p align="center"><CHECK MOTOR.></p> <ul style="list-style-type: none"> • The motor normally operates with its white (+) and black (-) lead wires connected to 12V DC. 	NO Replace motor.
	OK	

(to be continued)

When there is no speed control.

<CHECK FET CIRCUIT BLOCK.>
 Remove the FET circuit block and check the lead wire terminals. These terminals are open normal when there is an open circuit ($\infty\Omega$) between the green and red lead wires, and between the green and black lead wires.

NO
 FET circuit block replacement.

OK

<CHECK SWITCH BLOCK.> (See Fig. 1 & 2)
 Note: When check continuity of the switch, remove all lead wires from switch block.
 * Check by switch depression amount.
 (a) When the switch handle is pulled approximately 3mm :
 • There should be continuity between ③ and ④.
 • There should be no continuity between ② and ④.
 (b) When the handle is pulled all the way :
 • There should be continuity between ③ and ④, and between ② and ④.
 * Inspection of the forward / reverse selection switch. (See Fig. 1 & 2)
 (c) When the switch handle is not depressed :
 • There should be 0Ω between ① and ⑥ when the switch lever is set to the (A) side.
 • There should be 0Ω between ① and ⑤ when the switch lever is set to the (B) side.
 (d) When the switch handle is depressed all the way :
 • With touching (-) terminal of Volt-Ohm meter to ①, there should be 0Ω between ④ and ⑤ when the switch lever is set to the (A) side.
 • With touching (+) terminal of Volt-Ohm meter to ④, there should be 0Ω between ④ and ⑥ when the switch lever is set to the (B) side.

NO
 Contacts inside the switch block are defective. Switch block replacement.

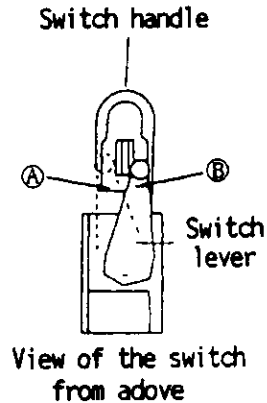

Fig.1

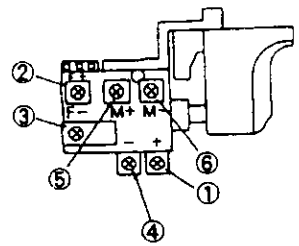

Fig.2

Does not charge.

<CHECK POWER CORD.>
 Check continuity.

NO
 Replace power cord.

OK

<CHECK MODULE.>
 Check the lamp indication of the battery charger.

NO
 Replace module in the charger.

Charging lamp Red	{ Flashing	Charger is plugged into power source. Ready to charge.
		— Lit	Now charging.
	 Flashing quickly	Charging is completed.

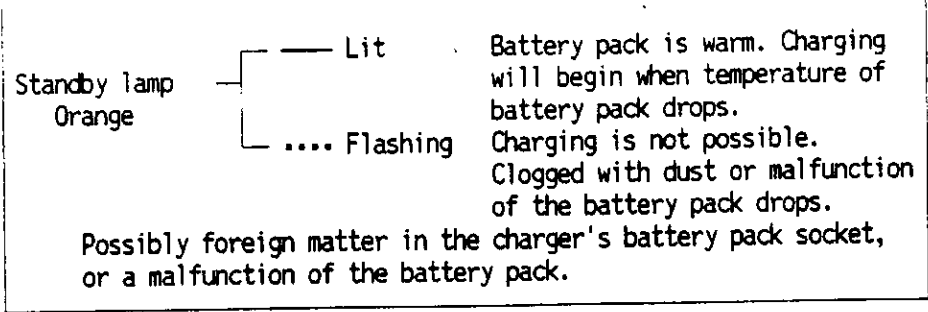

DISASSEMBLY/ASSEMBLY METHOD

- (Body Block) (See Fig. 3)
- After housings A and B are removed, the driver's internal mechanism can be disassembled into several blocks.
 - Reassembly should be done block-by-block, in the order of hammer block, output shaft block, and intermediate shaft block.
 - After having assembled the out put shaft block and hammer block into the housing, assemble the intermediate shaft block by first inserting its universal joint (A) into slot (B) in the hammer block, then fitting the shaft block into the bearing hole (C).

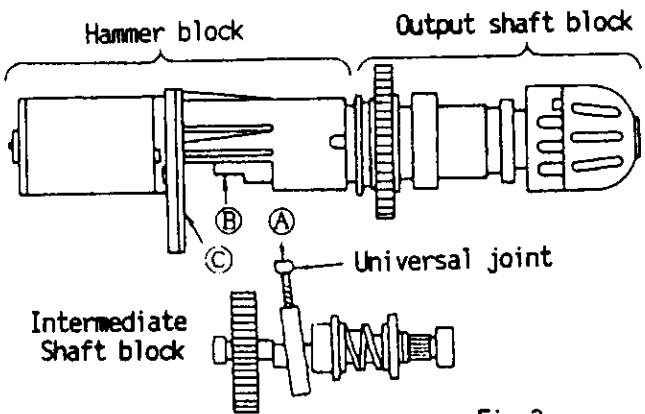

Fig.3

- (Output shaft block) (See Fig. 4)
1. To remove the chuck cover, insert a standard screwdriver into the clearance between the cover and chuck ring and pry the cover off.
 2. The chuck cam can be pulled out by removing the chuck cam stop ring.
 3. Remove 2 transmission keys and separate the chuck cover.
 4. When removing the clutch bush, notice the striker cushion and striker washer in it. When reassembling the bushing, be sure to replace the striker cushion first.

- (Intermediate shaft block) (See Fig. 5)
1. The flexible joint and flexible joint spring can be removed from the intermediate shaft block.
- Note: This block serves in switching the tool from hammer to drill and vice versa.

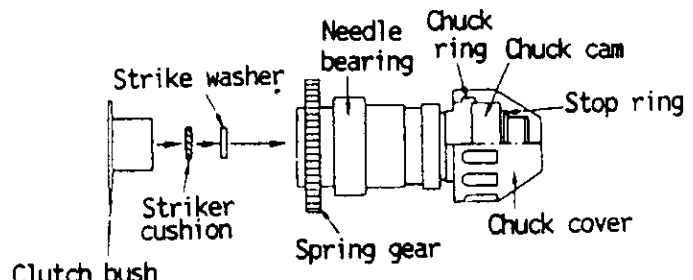

Fig.4

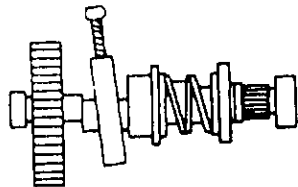

Fig.5

(Hammer block) (See Fig. 6)

1. Remove 2 motor screws and separate the hammer block from motor.
2. Remove piston and hammer block from base plate. When inserting the hammer into the piston, make sure that its orientation is correct.

Note: To take out the hammer block from the piston, clean around the exhaust hole.

Note: In particular, the hammer block's base plate, piston, and hammer require adequate greasing as they are subject to heating from compressed air.

Note: Air compressed by the piston drives hammer. Take care to protect the base plate, piston, and hammer from contamination by dust.

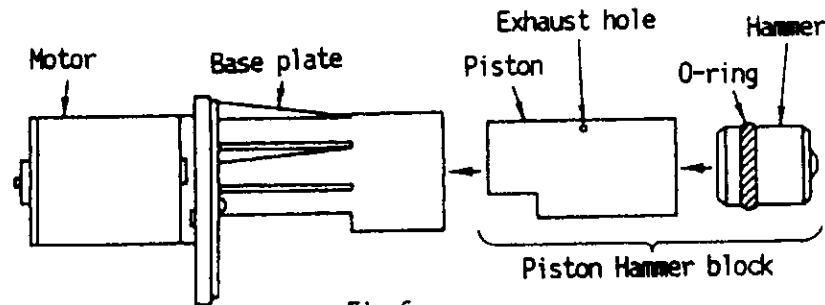
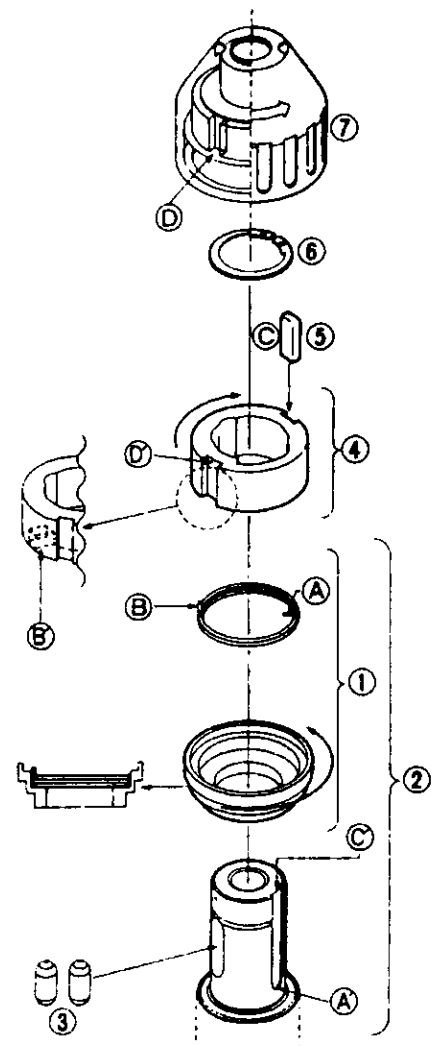

Fig.6

ASSEMBLY INSTRUCTIONS

- ① Check the direction of the chuck spring with setting (B) part upward. Press and wring the spring into the chuck ring.
- ② Insert the chuck ring block into the output shaft block with adjusting the (A) part of spring to (A') part of output shaft block.
- ③ Put the transmission key right and left side of the output shaft block.
- ④ Assemble the chuck cam with setting (B') part downward to the output shaft block.
Note: After inserting the chuck cam into the output shaft block, slightly turn the chuck cam clockwise direction; and turn the chuck ring counterclockwise direction to adjust the (B) part of spring to (B') part of chuck cam.
- ⑤ Insert the chuck key (C) into the output shaft block (C') part.
- ⑥ Set the stop ring.
- ⑦ Assemble the chuck cover with fitting the (D) part of chuck cover and (D') part of chuck cam.



Free Manuals Download Website

<http://myh66.com>

<http://usermanuals.us>

<http://www.somanuals.com>

<http://www.4manuals.cc>

<http://www.manual-lib.com>

<http://www.404manual.com>

<http://www.luxmanual.com>

<http://aubethermostatmanual.com>

Golf course search by state

<http://golfingnear.com>

Email search by domain

<http://emailbydomain.com>

Auto manuals search

<http://auto.somanuals.com>

TV manuals search

<http://tv.somanuals.com>