

Service Manual

Cordless Rotary Hammer

EY6813-U1

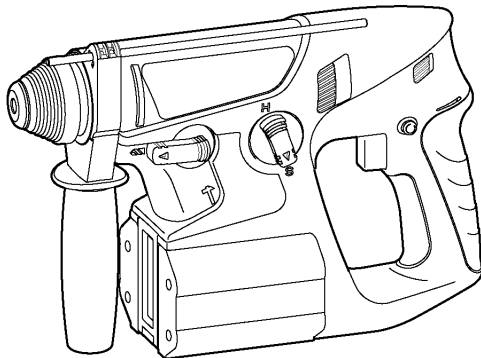

SPECIFICATIONS

MAIN UNIT

Maximum Drilling Diameter	Concrete	20mm (25/32")
	Steel	13mm (33/64")
	Wood	27mm (1-1/16")
Motor Voltage	DC Motor 24V	
Speed at No Load (RPM)	Slow Mode	0 ~ 520/min (rpm)
	High Mode	0 ~ 950/min (rpm)
Blows Rate Per Minute (BPM)	Soft Mode	0 ~ 3100/min (bpm)
	Hard Mode	0 ~ 4600/min (bpm)
Weight (with battery pack)	4.35kg (9.6lbs.)	
Dimensions (LxWxH)	316x206x74mm (12-28/64"x8-7/64"x2-58/64")	

⚠ WARNING

This service information is designed for experienced repair technicians only and is not designed for use by the general public. It does not contain warnings or cautions to advise non-technical individuals of potential dangers in attempting to service a product. Products powered by electricity should be serviced or repaired only by experienced professional technicians. Any attempt to service or repair the product or products dealt with in this service information by anyone else could result in serious injury or death.

CONTENTS

	Page		Page
1 SCHEMATIC DIAGRAM	2	5 TRIAL OPERATION(after checking TROUBLESHOOTING GUIDE.)	8
2 WIRING CONNECTION DIAGRAM	2	6 EXPLODED VIEW	9
3 DISASSEMBLY/ASSEMBLY INSTRUCTIONS	3	7 REPLACEMENT PARTS LIST	10
4 TROUBLESHOOTING GUIDE	6		

Panasonic®

© 2002 Matsushita Electric Works Ltd. All rights reserved. Unauthorized copying and distribution is a violation of law.

1 SCHEMATIC DIAGRAM

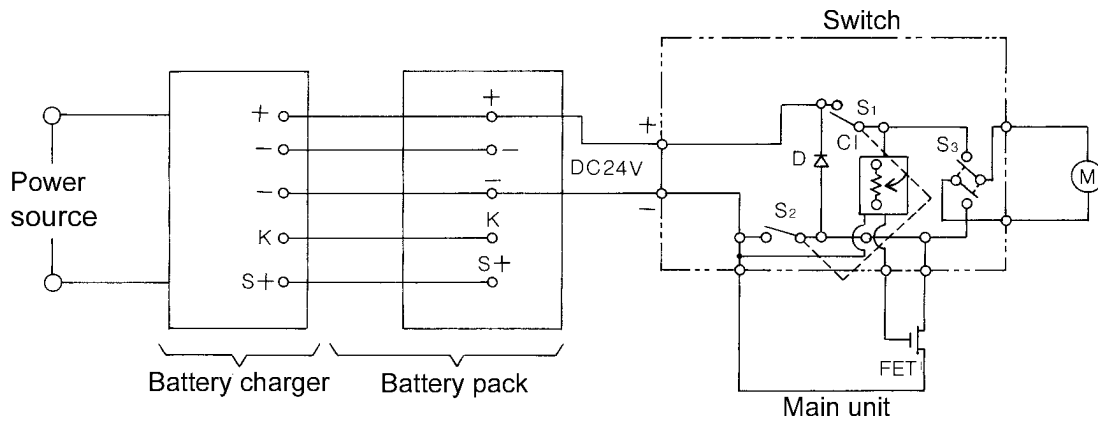

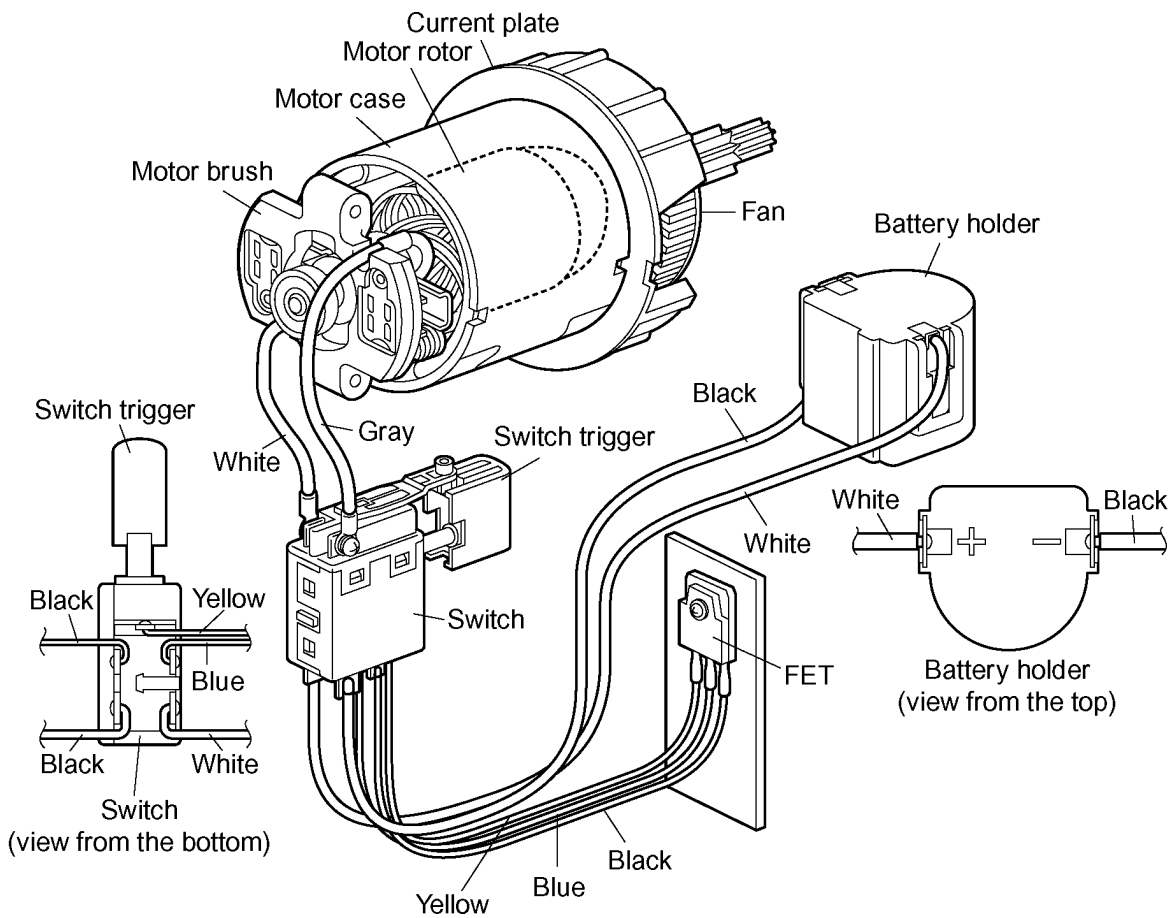

2 WIRING CONNECTION DIAGRAM

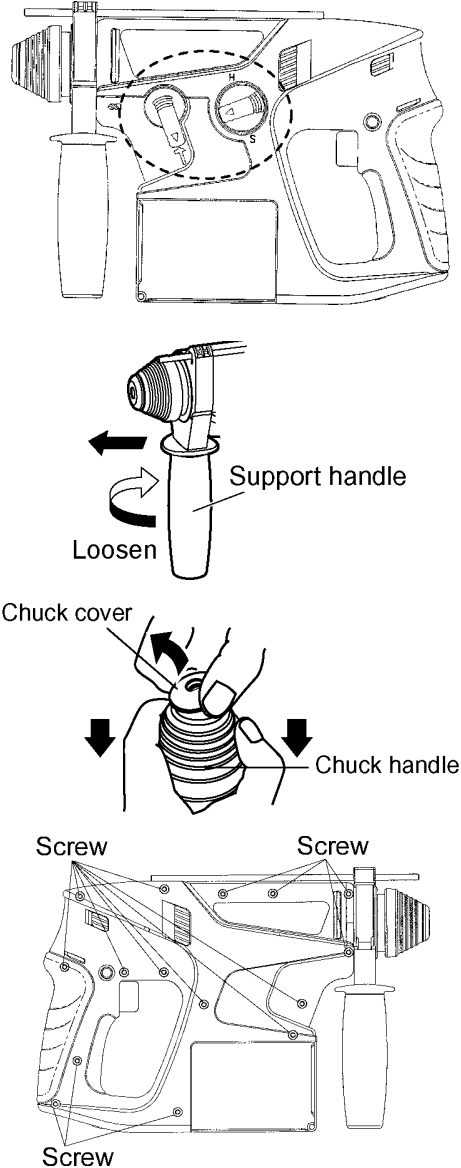

3 DISASSEMBLY/ASSEMBLY INSTRUCTIONS

■ HOW TO DISASSEMBLE THE MAIN UNIT.

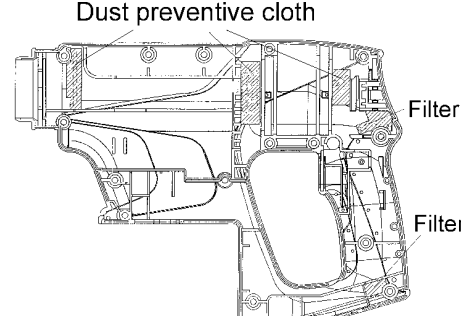
Ref. No. 1A	Procedure 1A	Removal of the housing.
 <p>Support handle</p> <p>Loosen</p> <p>Chuck cover</p> <p>Chuck handle</p> <p>Screw</p> <p>Screw</p> <p>Screw</p>		<p>Removal of the housing.</p> <ol style="list-style-type: none"> 1. Set the hammering/drilling switching lever to the position  and the speed/blow mode selection lever in between "H" and "S" position. 2. Loosen the support handle and take it out from the unit. 3. Pluck the chuck cover depressing the chuck handle. 4. Remove 15 housing screws. <p>For assembling</p> <p>NOTE : Make sure to attach the dust preventive clothes or filters on the housings.</p>  <p>Dust preventive cloth</p> <p>Filter</p> <p>Filter</p>

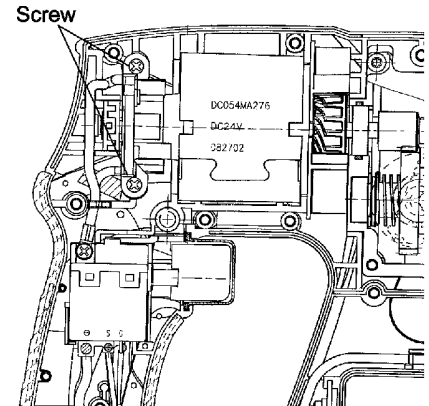
Ref. No. 1B	Procedure 1A→1B	Removal of the motor brush assembly.
 <p>Screw</p> <p>DC054WA275</p> <p>DC24V</p> <p>202/02</p>		<ol style="list-style-type: none"> 1. Loosen 2 screws.

■HOW TO DISASSEMBLE MAIN UNIT.

Ref. No. 2A

Procedure 1A→1B→2A

Removal of the switch.

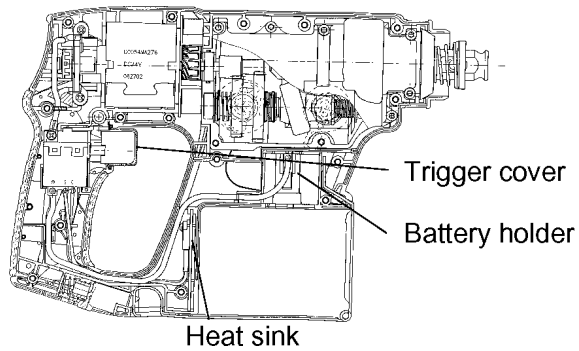

1. Take out the heat sink from the housing by something like a plier.
2. Take out the battery holder from the housing.
3. Remove the trigger cover.

For assembling

NOTE:

Make sure to set the trigger cover into the groove of housing.

Ref. No. 2B

Procedure 1A→1B→2A→2B

Removal of the motor assembly.

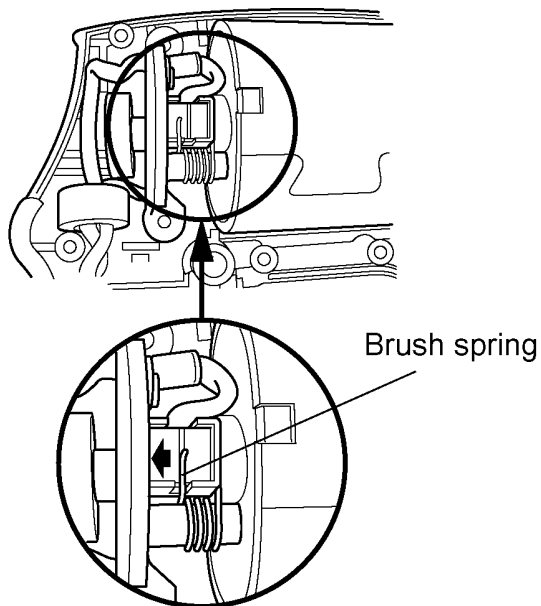

1. Hitch the brush spring to the frame by something like a forceps and take the motor brush assembly with the switch out from the motor assembly.
2. Take out the rotor and the current plate from the motor case.

For assembling

NOTE:

Make sure to return the spring into the groove of the motor brush.

Make sure to align the groove of motor case and the groove of current plate. And set the largest groove of the motor case onto the boss of housing.

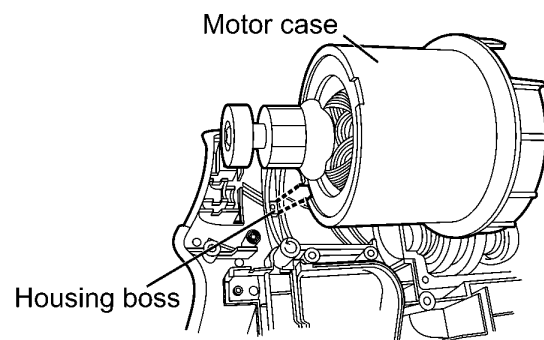
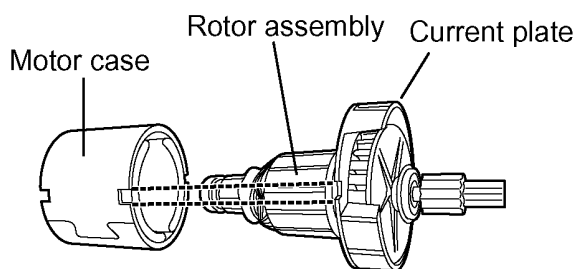

■HOW TO DISASSEMBLE THE GEAR BOX BLOCK.

Ref. No. 2C

Procedure 2A → 2B → 2C

Removal of the gear box block.

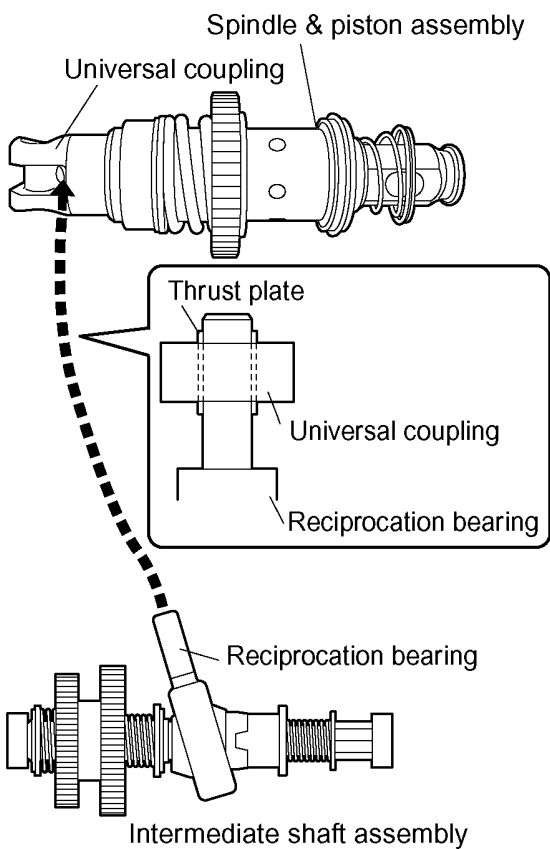
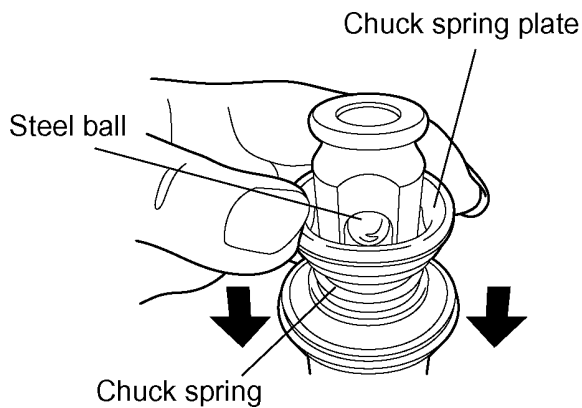
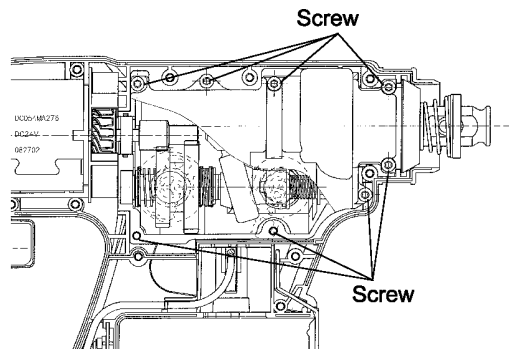

1. Loosen 8 screws of the gear case.
2. Take out a steel ball pushing the chuck spring with the chuck spring plate.
3. Remove the chuck spring, the chuck spring plate and the spindle & piston assembly.
4. Remove the intermediate shaft assembly.

For assembling

NOTE :

Every time the gear box block is opened, use the new gaskets and screws.

1. Assemble the bearing with the spindle assembly.
2. Fit O-ring onto the bearing. It is little loose.
3. Assemble the chuck spring and the chuck spring plate.
4. Insert a ball pushing down the chuck spring.
5. Insert the reciprocation bearing shaft into the hole of universal coupling. Make sure two thrust plates should be set both side of reciprocation bearing shaft one of each.

NOTE :

Greasing about 30g into the gear box block especially for the connection area between reciprocation bearing and universal coupling. In addition, hammer O-ring, inside of piston and cylinder for output shaft block also need to apply.

Air compressed by the piston drives hammer. Take care to protect the piston and hammer from contamination by dust.

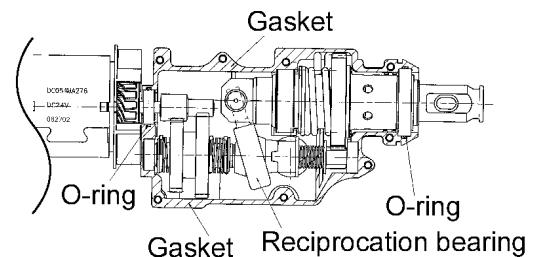

4 TROUBLESHOOTING GUIDE

(Refer to WIRING CONNECTION DIAGRAM)

4.1. CHECK POINTS FOR ELECTRICAL PARTS.

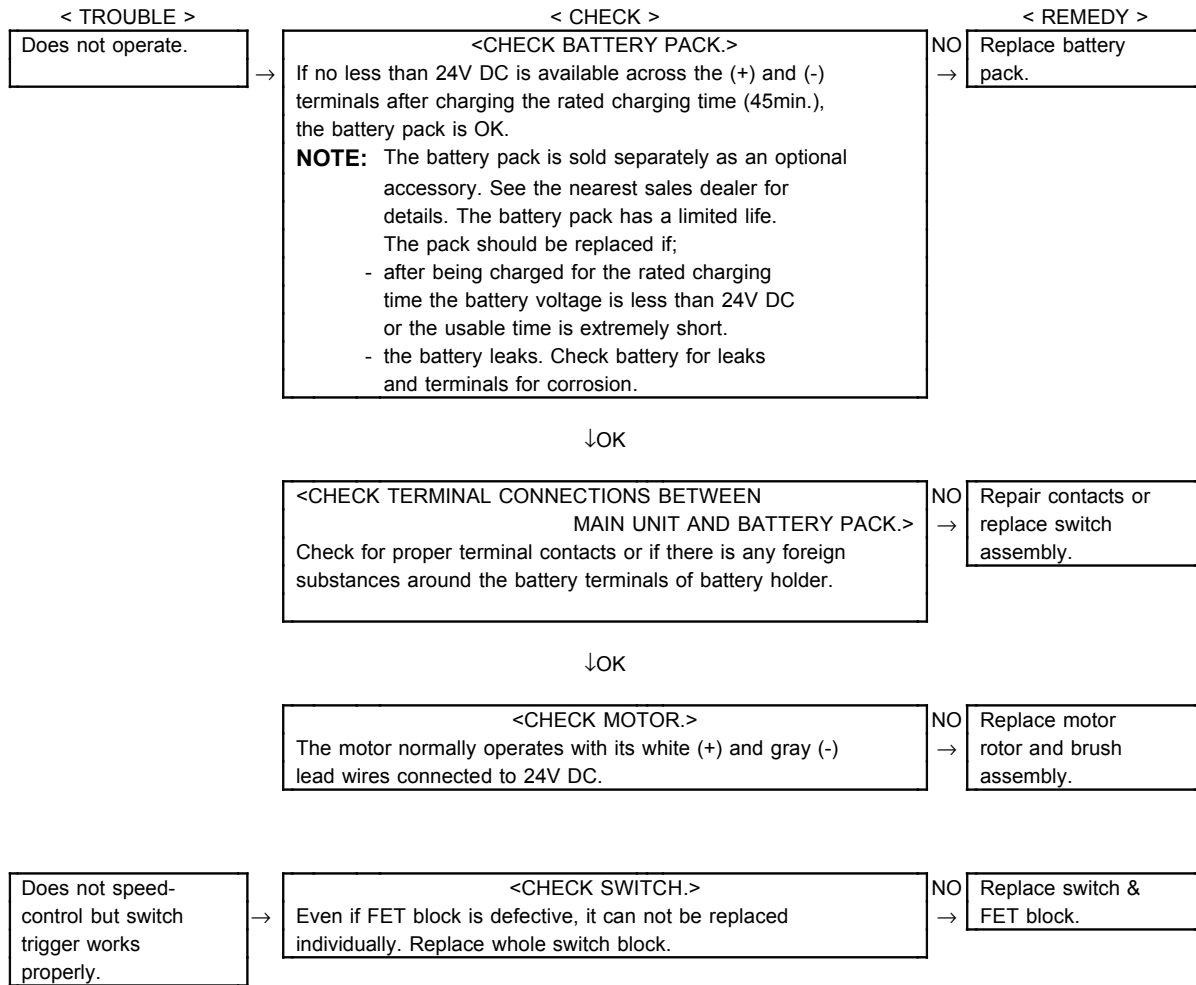

4.2. CHECK POINTS FOR MECHANISM BLOCK.

< TROUBLE >	< CHECK >	< REMEDY >
Does not hammer or weakness of hammering.	→ <CHECK INTERMEDIATE SHAFT ASSEMBLY.> Check the wear condition of the change clutch and spring.	NO → Replace intermediate shaft assembly.
↓OK		
<CHECK RECIPROCATION BEARING.> Check the smooth action between reciprocation bearing and universal coupling.		
↓OK		
<CHECK PISTON AND HAMMER BLOCK.> Check the wear condition of inside of piston and hammer O-ring.		
↓OK		
<CHECK STRIKER.> Check the smooth action of striker.		
↓OK		
<CHECK INTERMEDIATE SHAFT ASSEMBLY.> Check the wear condition on tooth for change gears.		
Does not drill.	→ <CHECK BEARING.> Check the condition of bearing for H/D handle.	NO → Replace H/D handle.
↓OK		
<CHECK O-RING.> Check the wear condition for O-rings assembled with striker.		
↓OK		
<CHECK RECIPROCATION BEARING.> Confirm the coming and going operation when rotating the intermediate shaft with DRILL mode. It is OK if the reciprocation bearing does not operate.		
↓OK		
<CHECK STRIKER.> Check the smooth action of striker.		
Does not change the speed.	→ <CHECK BEARING.> Check the condition of bearing for H/S handle.	NO → Replace H/S handle.
↓OK		
<CHECK INTERMEDIATE SHAFT ASSEMBLY.> Check the wear condition for both change gear "H" and "S".		

5 TRIAL OPERATION(after checking TROUBLESHOOTING GUIDE.)

5.1. HAMMER/DRILL

Confirm the action when setting the H/D handle to HAMMER mode.

Rotation with hammering when the drill bit touches something like stone, and power.

It is OK, if it takes about 7-10 seconds by 20kgf to hole (ϕ 12.5X40) on the concrete (pressure strength 240kgf/cm²).

Confirm the action when setting the H/D handle to DRILL mode.

No hammering when the drill bit touches iron plate.

5.2. SPEED CONTROL

Change the rotation speed from 0-950 rpm in proportion to the amount of pushing level on switch trigger.

5.3. REVERSING LEVER

Confirm the action with setting the reversing lever to FORWARD or REVERSE.

5.4. ASSEMBLY

Confirm pressing the lead wires between ribs, tightening screws firmly and replacing the new gasket and screws for the gear box block.

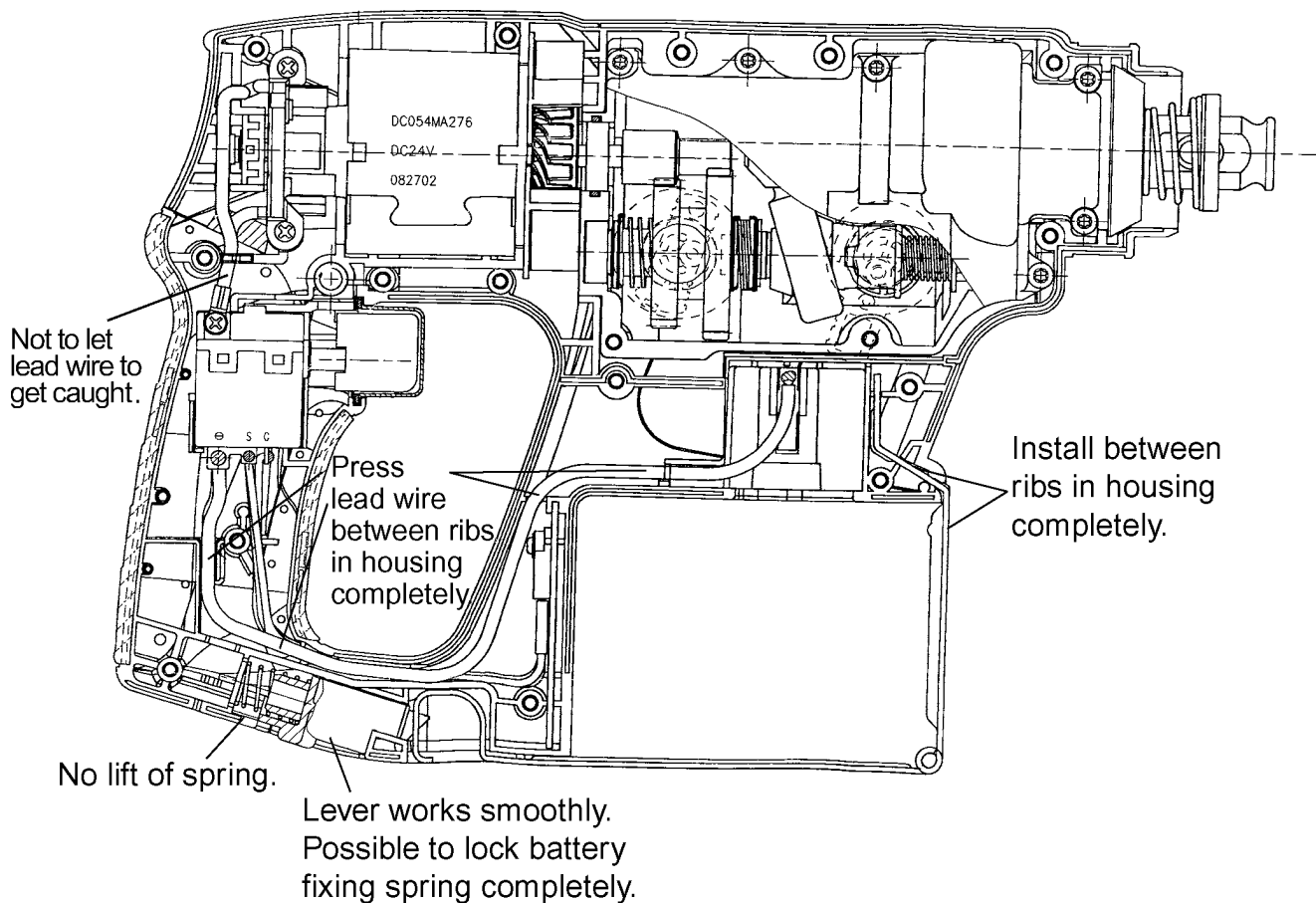

7 REPLACEMENT PARTS LIST

NOTE:

*B=only available as set

*C=available individually

Ref.No.	Part No.	Part Name & Description	Remarks	Per Unit
1	WEY6813K3078	HOUSING AB SET		1
2	WEY6813H3117	CHUCK COVER		1
3	WEY6813K3127	CHUCK HANDLE		1
4	WEY6813L0427	BALL GUIDE		1
5	WEY6813L1917	STEEL BALL	φ 7	1
6	WEY6813L0437	CHUCK SPRING STRIKE PLATE		1
7	WEY6813L0917	CHUCK SPRING		1
8	WEY6813L0367	O RING	φ 35	1
9	WEY6813L4058	SPINDLE ASSEMBLY		1
10	EY6812L0387	BEARING		1
11	WEY6813L4067	PISTON ASSEMBLY		1
12	EY6812L4627	HAMMER		1
13	EY6812L0977	O RING		1
14	WEY6813L1247	PISTON		1
15	WEY6813L1257	UNIVERSAL COUPLING		1
16	EY6812L0847	THRUST PLATE	*B (2PCS/PK)	2
17	WEY6813L4077	INTERMEDIATE SHAFT ASSEMBLY		1
18	WEY6813L0467	THRUST PLATE		1
19	WEY6813L0017	GEAR CASE A		1
20	WEY6813L0027	GEAR CASE B		1
21	WEY6813L0987	GASKET AB SET		1
22	WEY6813L9557	ALUMINUM TIGHT SCREW (M4X16)	*B (5PCS/PK)	8
23	WEY6813L0357	O RING		1
24	WEY6813L4627	MOTOR ROTOR ASSEMBLY		1
25	WEY6813L4987	MOTOR CASE ASSEMBLY		1
26	WEY6813L4637	MOTOR BRUSH ASSEMBLY		1
27	WEY6813L0447	CURRENT PLATE		1
28	EY574B9037	P TIGHT SCREW (K3X20)	*C	2
29	WEY6813L4157	SWITCH ASSEMBLY		1
30	EY6225L6027	SEMS SCREW (M3X5)	*C	2
31	WEY6813Y4607	H/D HANDLE		1
32	WEY6813Y4617	H/S HANDLE		1
33	WEY6813L0377	O RING	*C	2
34	WEY6813L0387	O RING	*C φ 15.5	2
35	WEY505B6967	STEEL BALL	*B (5PCS/PK)	2
36	WEY6813L1407	CLICK SPRING	*B (2PCS/PK)	2
37	WEY6813L0457	SNAP RING	*B (2PCS/PK)	2
38	WEY6813L3137	TRIGGER COVER		1
39	WEY6813L3147	F/R HANDLE		1
40	WEY6813D3157	RELEASE LEVER		1
41	EY6812L0177	SPRING A		1
42	EY6811K3817	BATTERY FIXING METAL ASSEMBLY		1
43	EY3503K6208	TAPPING SCREW (K4X20)	*C	15
44	WEY6813K4627	AUXILIARY HANDLE		1
45	WEY6813K4637	SUPPORT HANDLE		1
46	WEY6813H7727	DEPTH GAUGE		1
47	EY6812T7918	BIT GREASE		▲ 1
-	WEY6813X5517	THIXO GREASE		1
-	WEY6813K8108	OPERATING INSTRUCTIONS		▲ 1

** Battery Pack, Dust Collecting Cup and Tool Case are available as an optional accessory.

See the nearest sales dealer for details.

*** For replacement parts of charger, see the charger service manual.

Charger complete set is available as an optional accessory. See the nearest sales dealer for details.

Free Manuals Download Website

<http://myh66.com>

<http://usermanuals.us>

<http://www.somanuals.com>

<http://www.4manuals.cc>

<http://www.manual-lib.com>

<http://www.404manual.com>

<http://www.luxmanual.com>

<http://aubethermostatmanual.com>

Golf course search by state

<http://golfingnear.com>

Email search by domain

<http://emailbydomain.com>

Auto manuals search

<http://auto.somanuals.com>

TV manuals search

<http://tv.somanuals.com>