

PARABODY

Serious Steel

400101 HOME GYM

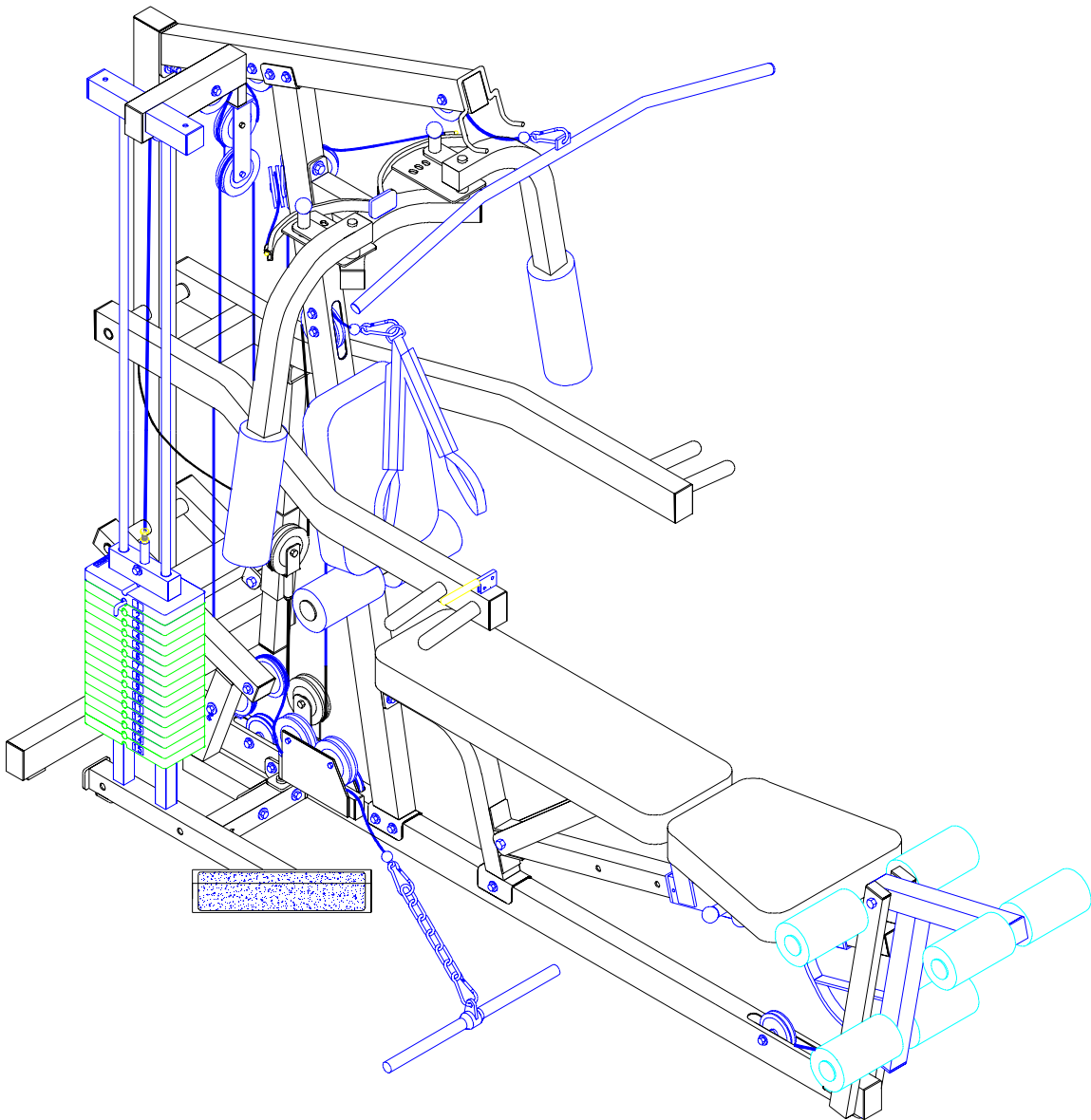

ASSEMBLY INSTRUCTIONS

IMPORTANT NOTES

WELCOME TO THE WORLD OF **Serious steel!**

Please note:

- * Thank you for purchasing the Parabody 400101 Home Gym. Please read these instructions thoroughly and keep them for future reference. This product must be assembled on a flat, level surface to assure its proper function.
- * We recommend cleaning your product (pads and frame) on a regular basis, using warm soapy water. Touch-up paint can be purchased from your Parabody customer service representative at (800) 328-9714.

There is a risk assumed by individuals who use this type of equipment. To minimize risk, please follow these rules:

1. Inspect equipment daily. Tighten all loose connections and replace worn parts immediately. Failure to do so may result in serious injury.
2. Do not allow minors or children to play on or around this equipment.
3. Exercise with care to avoid injury.
4. If unsure of proper use of equipment, call your local Parabody distributor or call the Parabody customer service department at (800) 328-9714.
5. Consult your physician before beginning any exercise program.

Tools Required for Assembly

- * Rubber mallet or hammer
- * 3/4" wrench
- * 9/16" wrench
- * Ratchet with 3/4" and 9/16" sockets
- * 5/32" Allen wrench
- * Adjustable wrench
- * Tape measure

Bolt Length Ruler

NOTE: BOLT LENGTH IS MEASURED FROM THE UNDERSIDE OF THE HEAD OF THE BOLT.

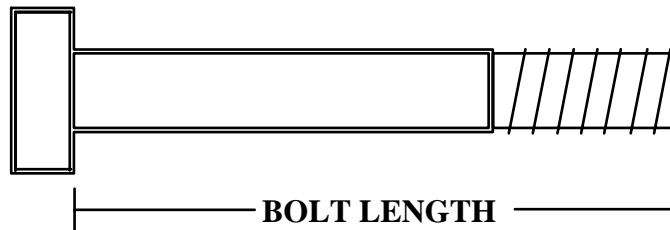

BOLT LENGTH RULER:

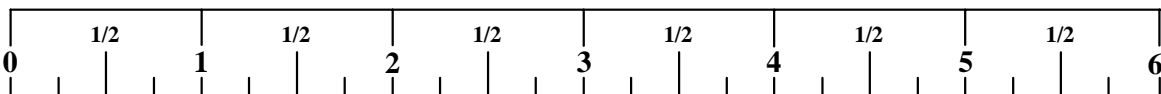

PARTS LIST

KEY	PART #	DESCRIPTION	QTY	KEY	PART #	DESCRIPTION	QTY
1	6746903	FRAME SUPPORT	1	49	3102801	1/2" NYLOCK NUT	11
2	6683302	WOLFF SLEEVE	1	50	3102804	1/2" LOW HT. NYLOCK NUT	6
3	6682803	WEIGHT STACK BASE	1	51	3102501	3/8" WASHER	33
4	6679903	LEG CURL/EXTENSION	1	52	3102502	1/2" WASHER	14
5	6686802	PULLEY BRACKET	1	53	3102503	3/4" WASHER	2
6	6679503	ADJUSTMENT SLIDE	1	54	3109602	PAL NUT	1
7	6678603	TOP BOOM	1	55	6686301	1/2" DIA U-PIN	1
8	6683103	PRESS ARM	1	56	6075906	CHAIN	1
9	6680402	PRESS ARM LEVER	1	57	6214401	WEIGHT STACK PIN	1
10	6682103	BASE	1	58	6533501	CABLE RETAINING CLIP	4
11	6682503	FRONT UPRIGHT	1	59	6321201	CONTROL LEVER	1
12	6681303	LEVER STOP	1	60	3119201	8-32 X 3/16" SCREW	2
13	6680202	RECEIVING TUBE	1	61	3119101	3/8" JOINT CONNECTOR CAP	2
14	6683802	BACK PAD SUPPORT	1	62	3117901	E-RING	1
15	6746803	BENCH FRAME	1	63	3119401	#8 INT. TOOTH LOCKWASHER	2
16	6680903	REAR UPRIGHT	1	64	3118401	4" VINYL CAP	1
17	6680803	BEARING HOUSING	1	65	3106803	5/32" SET SCREW	4
18	6681902	PLATE, 1/4 X 2 X 16-1/2"	2	66	6480301	3/8" FLANGE SPACER	16
19	6532903	PEC ARM RIGHT	1	67	6020601	1/2" FLANGE BEARING	6
20	6532803	PEC ARM LEFT	1	68	6019701	3/4" THRUST BEARING	2
21	6530203	CENTER PULLEY BRACKET	1	69	3104901	3/4" FLANGE BEARING	8
22	6594702	FLOATING PULLEY	2	70	6416601	1-3/4 X 3/4" PARAGLIDE	1
23	6624402	SWIVEL PULLEY BRACKET	1	71	6412001	SPRING PIN ASSEMBLY	3
24	6529702	PEC CAM	2	72	3103801	5/16" DIA SNAP LINK	4
25	6275302	LAT BAR	1	73	3105401	STARLOCK COLLAR	10
26	6654302	33-1/2 X 9-1/2" BACK SEAT PAD	1	74	6214501	WEIGHT PLATE	15
27	6597402	15-1/2 X 10-1/2" PEC SEAT PAD	1	75	6692601	3 X 2" END CAP	2
28	6681502	15-3/4 X 15-1/2" LEG SEAT PAD	1	76	6405201	2" SQ. END CAP	2
29	6690901	3/4 DIA X 11" SHAFT	2	77	6236701	1-3/4" SQ END CAP	1
30	6125102	3/4 OD X 16" TUBE	4	78	6406401	HINGE TAB	2
31	6194601	4 X 7" ROLLER PAD	8	79	3116201	3-1/2" PULLEY	19
32	6176201	PEC DEC ROLLER PAD	2	80	6266001	WEIGHT STACK SHAFT	1
33	6523401	3/4 X 72-3/8" GUIDE ROD	2	81	6714601	HEAD PLATE	1
34	6375902	WEIGHT STACK SPACER	2	82	6375801	STRAP AB CRUNCH	1
35	3102909	3/8 X 1" BOLT	4	83	6389701	LOW ROW BAR	1
36	3102924	3/8 X 1-3/4" BOLT	5	84	6409101	STRAP ANKLE	1
37	3102933	3/8 X 2" BOLT	4	85	3116001	1-1/4" BUMPER RUBBER	1
38	3102922	3/8 X 2-3/4" BOLT	11	86	6270501	4 X 14" NON-SKID	1
39	3102904	3/8 X 3" BOLT	5	87	6140701	1 X 1" GLIDE	4
40	3102905	3/8 X 3-3/4" BOLT	2	88	3108002	WEIGHT STACK CUSHION	2
41	3102906	3/8 X 4" BOLT	4	89	3117401	CAP PLUG	2
42	3102910	1/2 X 3" BOLT	8	90	6687101	227" LEG EXT. CABLE	1
43	3102943	1/2 X 3-1/2" BOLT	5	91	6687201	72-1/4" AB CABLE	1
44	3102917	1/2 X 4" BOLT	2	92	6687001	103-1/2" LAT CABLE	1
45	3102937	1/2 X 4-1/2" BOLT	3	93	6535601	77-5/8" PEC DEC CABLE	1
46	3102901	3/8 X 1-1/4" BOLT	1	94	6189501	WEIGHT STACK LABELS	1
47	6382301	WEIGHT PLATE BUSHING 10CT	3	95	6145801	THUMBSCREW	1
48	3102802	3/8" NYLOCK NUT	29				

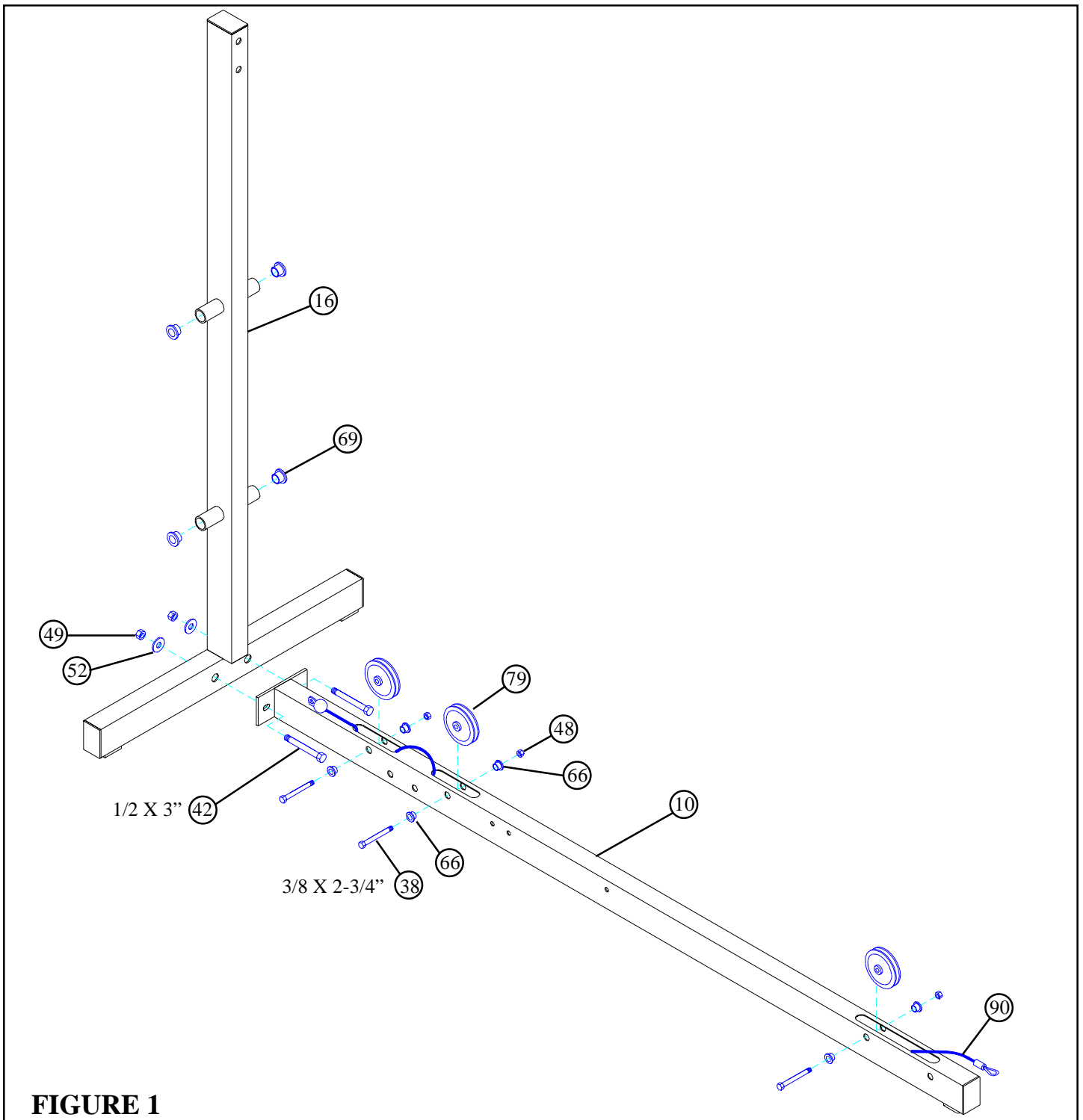

FIGURE 1

STEP 1

- Securely assemble REAR UPRIGHT (16) to BASE (10) using two 1/2 X 3" BOLTS (42), two 1/2" WASHERS (52), and two 1/2" LOCKNUTS (49).
- Slide 227" CABLE ASSEMBLY (90) through openings in BASE (10) as shown in FIGURE 1.
- Securely assemble three 3-1/2" PULLEYS (79) into BASE (10) using three 3/8 X 2-3/4" BOLTS (38), six 3/8" FLANGE SPACERS (66), and three 3/8" LOCKNUTS (48). (**NOTE: Make sure 227" CABLE ASSEMBLY (90) is routed under PULLEYS and BOLTS.**)
- Insert four 3/4" FLANGE BEARINGS (69) into tubes on REAR UPRIGHT (16) as shown in FIGURE 1

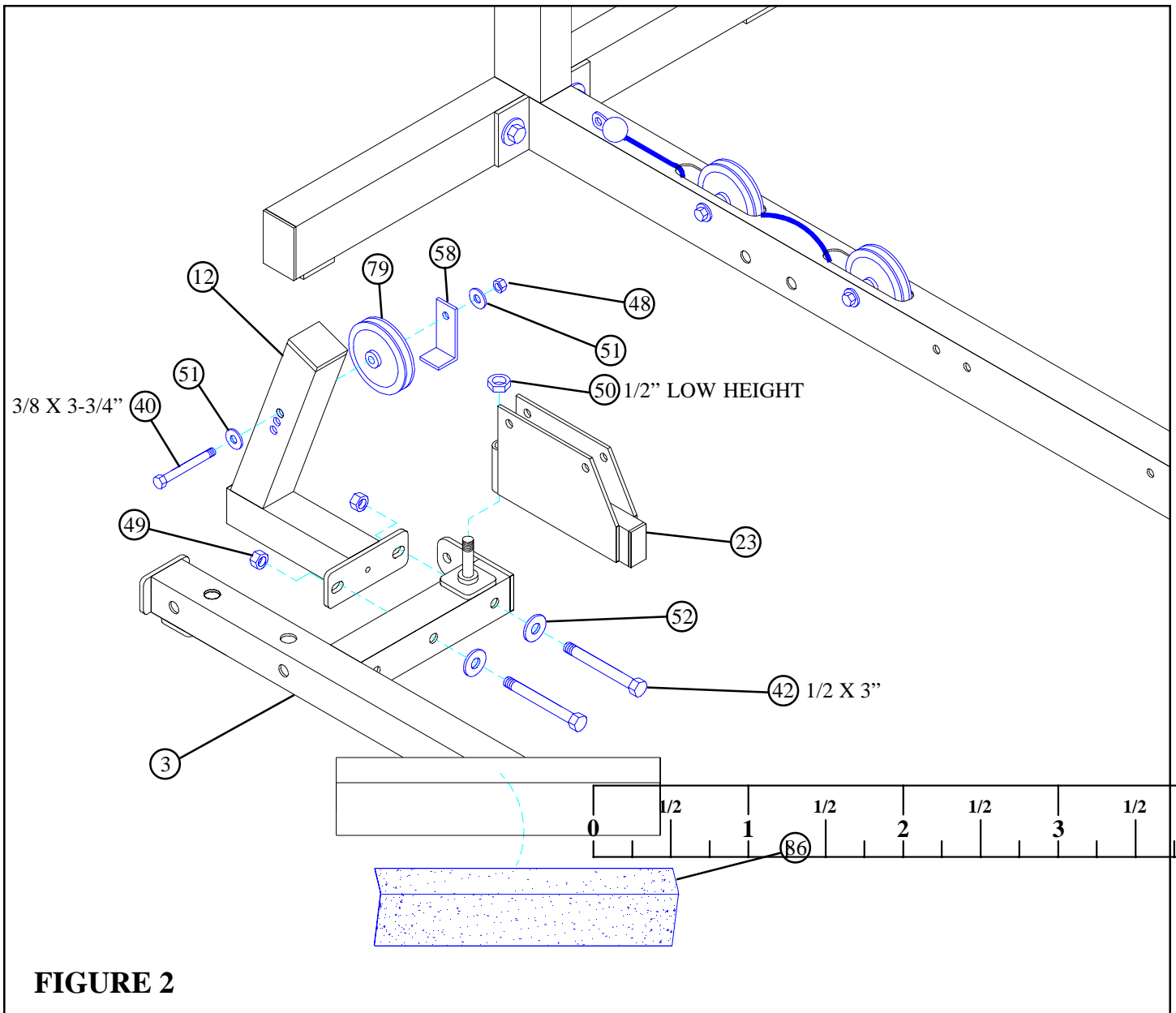

FIGURE 2

STEP 2

- Securely assemble one 3-1/2" PULLEY (79) to the top hole of the LEVER STOP (12) using one 3/8 X 3-3/4" BOLT (40), two 3/8" WASHERS (51), one 2-3/8" RETAINING CLIP (58), and one 3/8" LOCKNUT (48). The extra holes in the LEVER STOP (12) are to be used for cable adjustment.
- Securely attach LEVER STOP (12) to WEIGHT STACK BASE (3) using two 1/2 X 3" BOLTS (42), two 1/2" WASHERS (52), and two 1/2" LOCKNUTS (49).
- Attach SWIVEL PULLEY BRACKET (23) to the WEIGHT STACK BASE (3) using one 1/2" LOW HEIGHT LOCKNUT (50). (**NOTE:** Securely tighten, then back nut off 1/4 turn to allow the SWIVEL PULLEY BRACKET (23) to rotate freely.)
- Center 4 X 14" NON SKID STRIP (86) on WEIGHT STACK BASE (3) as shown in FIGURE 2.

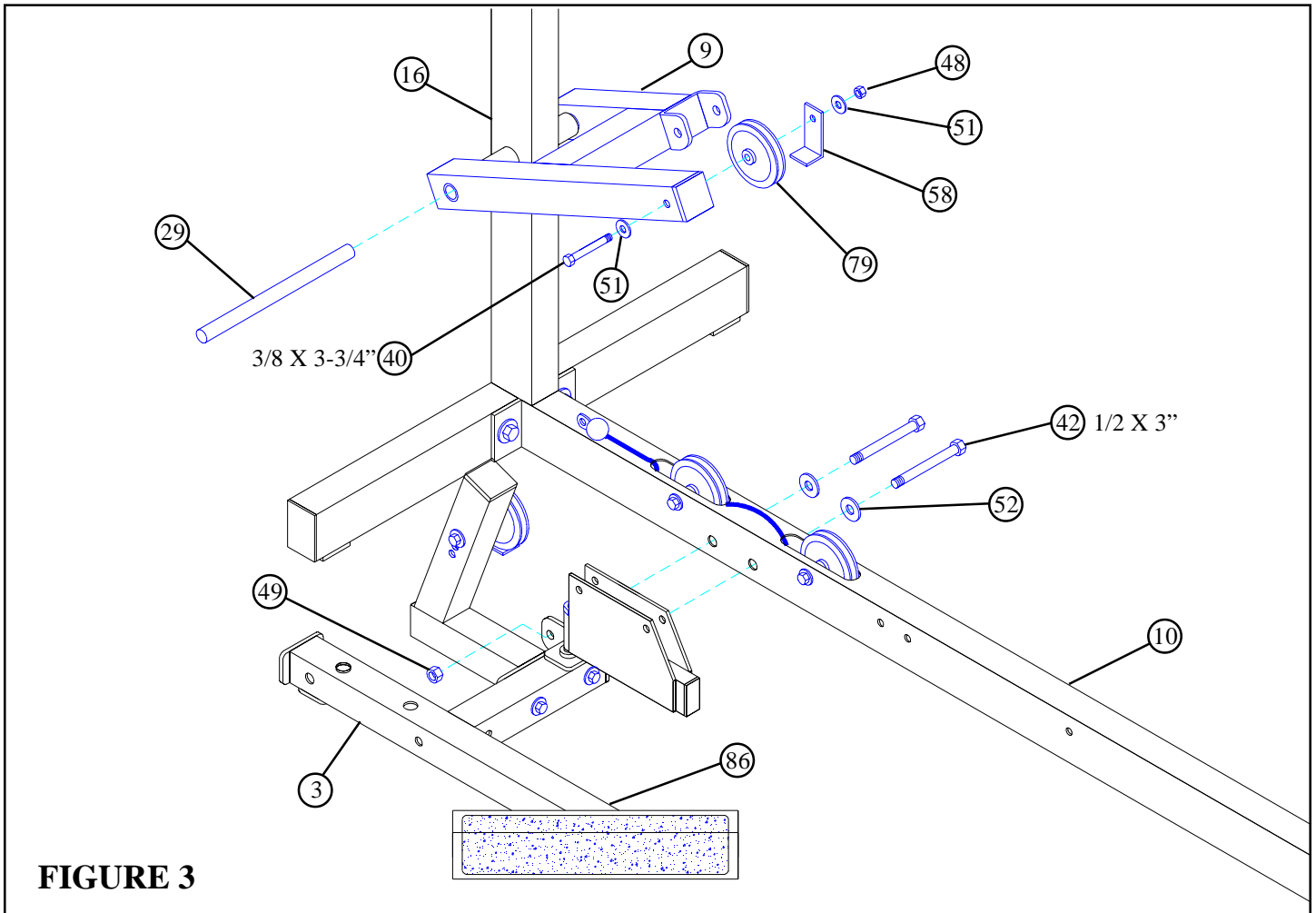

FIGURE 3

STEP 3

- Securely attach WEIGHT STACK BASE (3) to BASE (10) using two 1/2 X 3" BOLTS (42), two 1/2" WASHERS (52), and one 1/2" LOCKNUT (49).
- Slide one 3/4 DIA X 11" SHAFT (29) through PRESS ARM LEVER (9) & tube on REAR UPRIGHT (16). See FIGURE 3.
- Securely assemble one 3-1/2" PULLEY (79) to PRESS ARM LEVER (9) using one 3/8 X 3-3/4" BOLT (40), two 3/8" WASHERS (51), one 2-3/8" RETAINING CLIP (58), and one 3/8" LOCKNUT (48).

STEP 4

- Apply eight 1-3/4 x 3/4" PARAGLIDES (70) to the INSIDE of RECEIVING TUBE (13) as shown in FIGURE 4. (NOTE: Thoroughly clean the inside surface before attaching PARAGLIDES.)

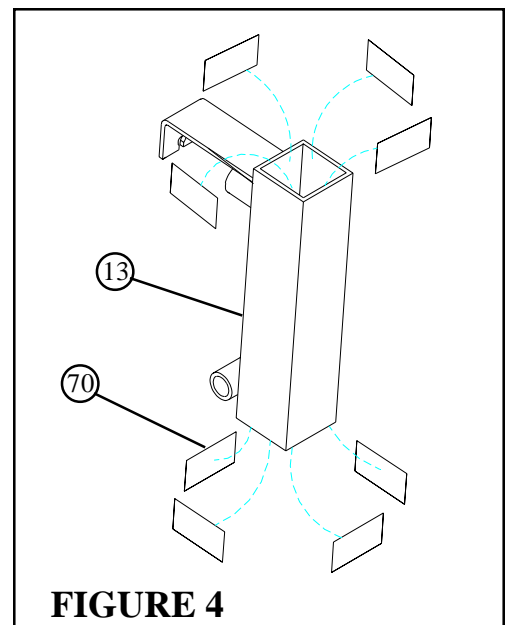
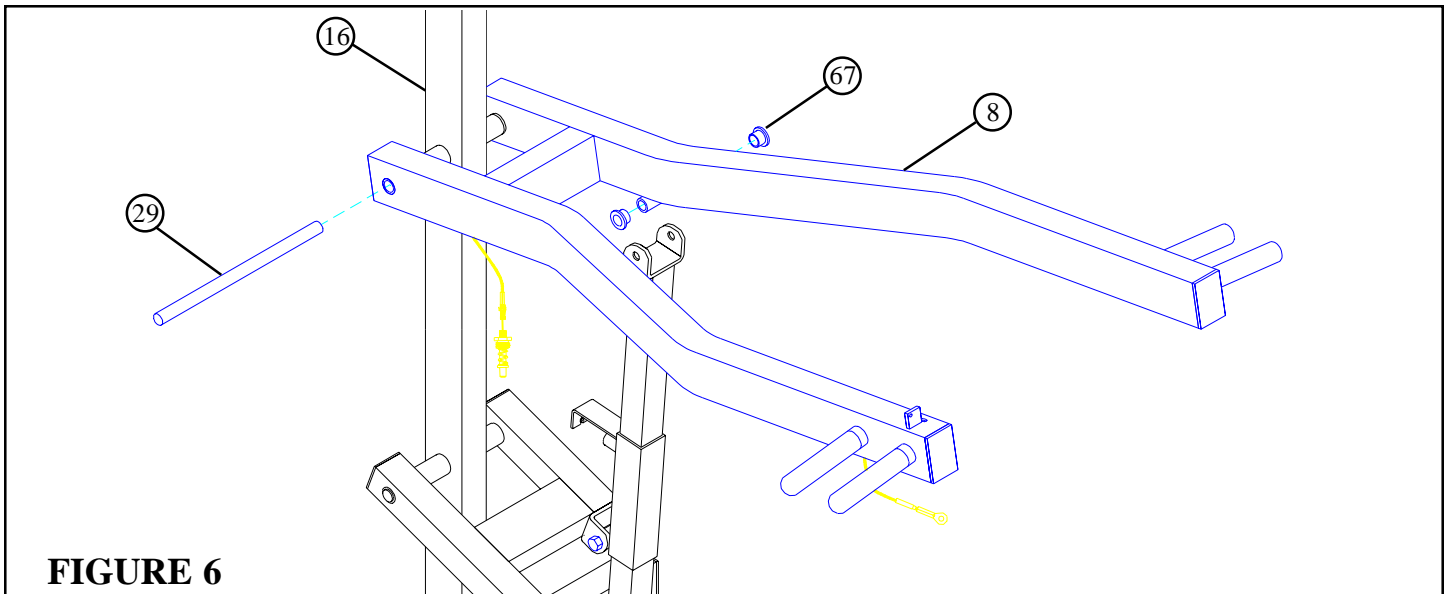
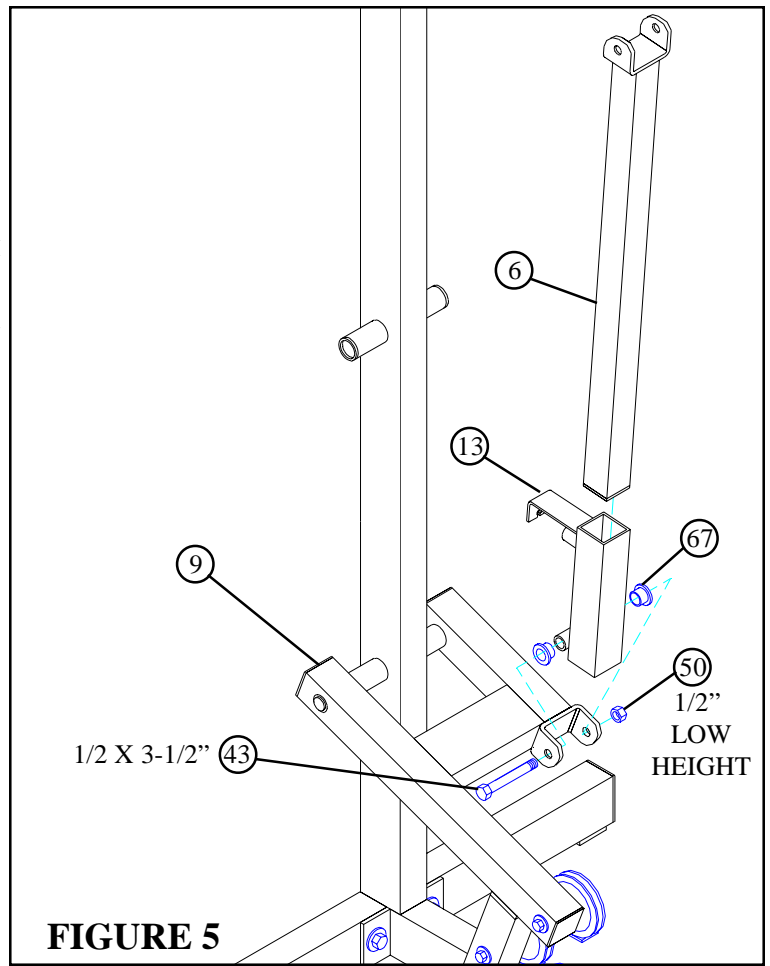

FIGURE 4

STEP 5

- Insert two 1/2" FLANGE BEARINGS (67) into RECEIVING TUBE (13).
- Attach RECEIVING TUBE (13) to PRESS ARM LEVER (9) using one 1/2 X 3-1/2" BOLT (43), and 1/2" LOW HEIGHT LOCKNUT (50). (NOTE: Securely tighten, then back nut off 1/4 turn to allow the RECEIVING TUBE (13) to rotate freely.)
- Insert the ADJUSTMENT TUBE (6) into the RECEIVING TUBE (13) as shown in FIGURE 5.



STEP 6

- Slide one 3/4 DIA X 11" SHAFT (29) through PRESS ARM (8) & tube on REAR UPRIGHT (16). See FIGURE 6.
- Insert two 1/2" FLANGE BEARINGS (67) into PRESS ARM (8).

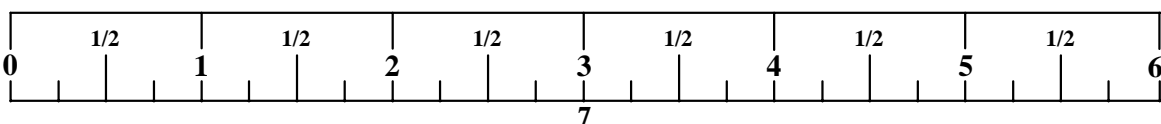

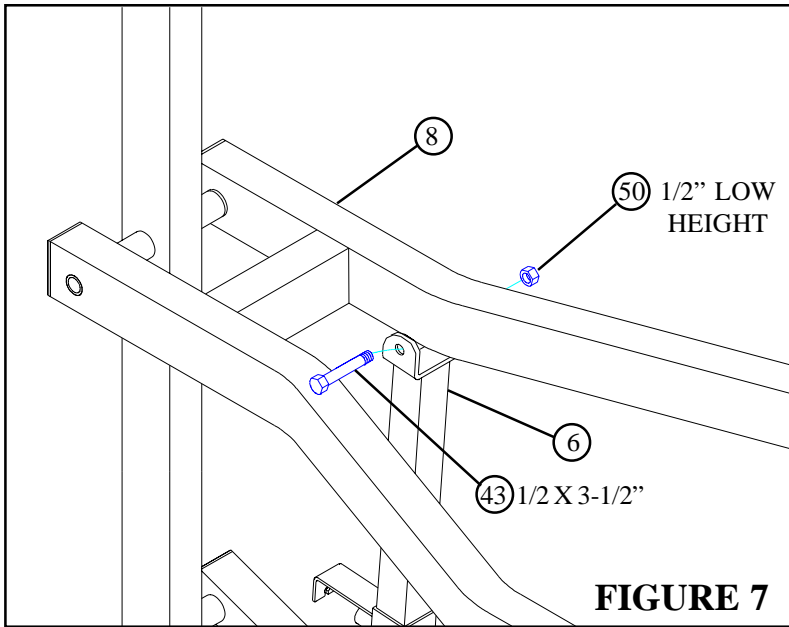

STEP 7

- Attach ADJUSTMENT SLIDE (6) to PRESS ARM (8) using one 1/2 X 3-1/2" BOLT (43), and 1/2" LOW HEIGHT LOCKNUT (50). (NOTE: Securely tighten, then back nut off 1/4 turn to allow the PRESS ARM (8) to rotate freely.)

STEP 8

- Insert the PUSH/PULL CABLE through the bottom of the PRESS ARM (8) up to the CONTROL LEVER (59) and hold in place with one E-RING (62) as shown in FIGURE 8.
- Securely assemble the PUSH/PULL CABLE to the CONTROL LEVER (59) using one 3/8 IN. JOINT CONNECTOR CAP (61), one #8 INT. TOOTH LOCK WASHER (63), and one 8-32 X 3/16 IN. SCREW (60) as shown in FIGURE 8.
- Slide one 4" VINYL SLEEVE (64) over the CONTROL LEVER (59). Then SECURELY assemble the CONTROL LEVER (59) to the TAB on the PRESS ARM (8) using one 3/8" JOINT CONNECTOR CAP (61), one #8 INT. TOOTH LOCK WASHER (63), and one 8-32 X 3/16 IN. SCREW (60) as shown in FIGURE 8.

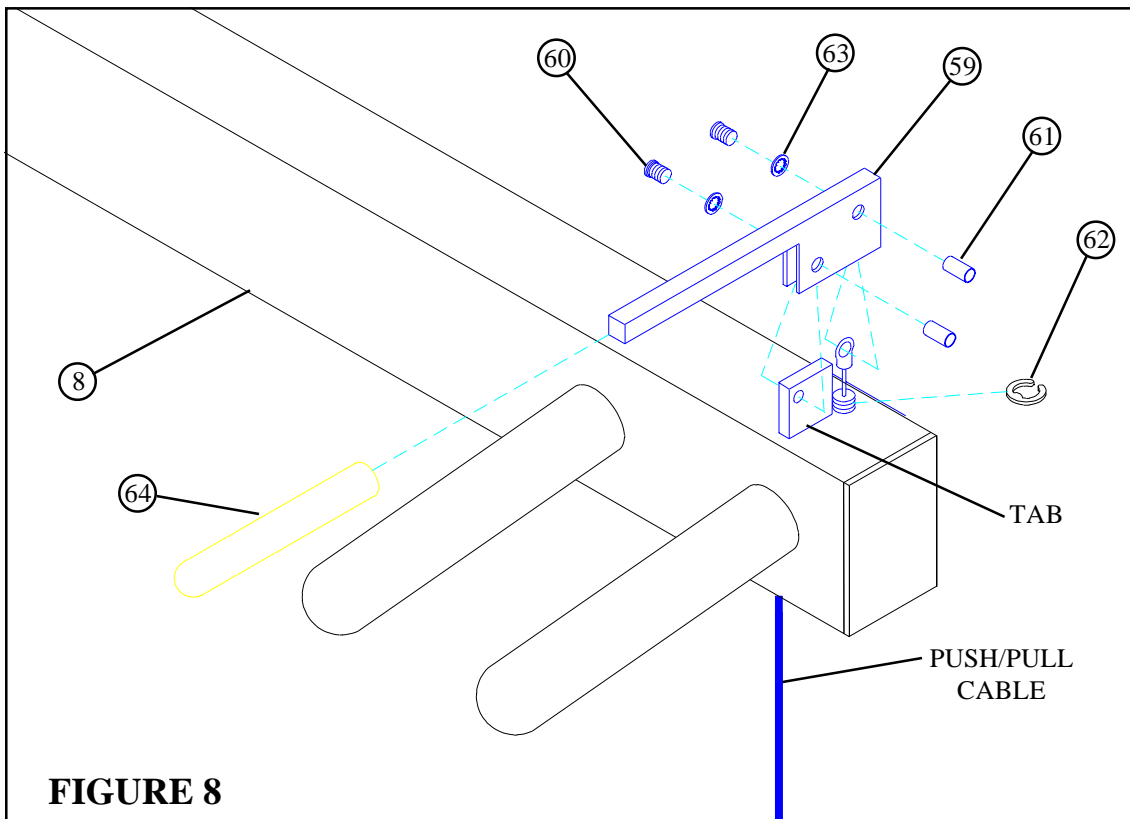

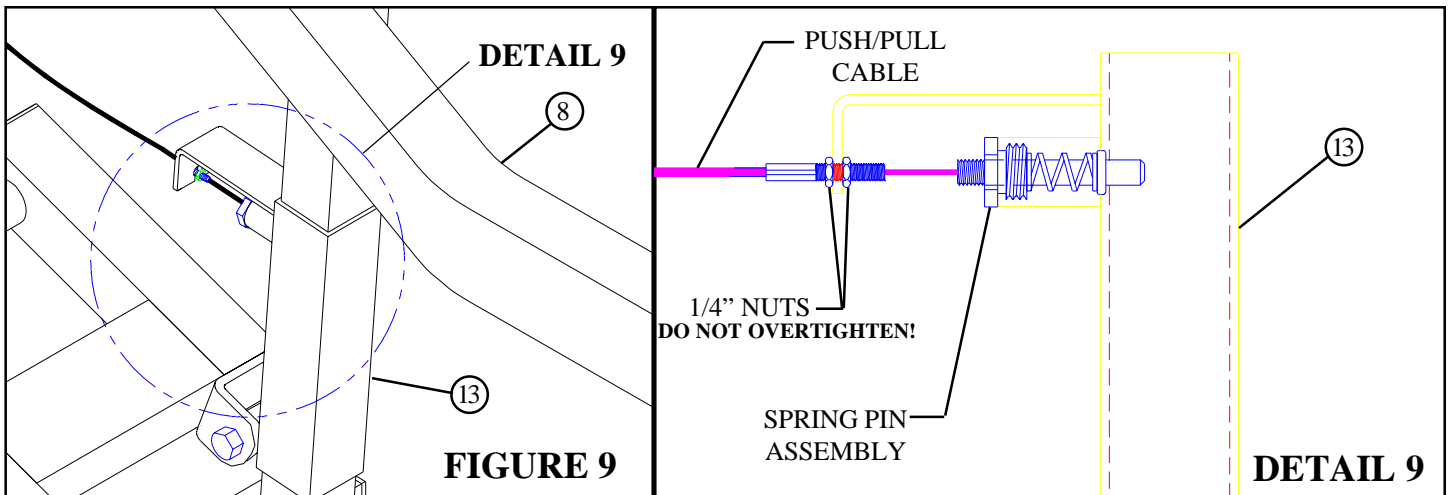

STEP 9

Assemble the PUSH/PULL CABLE from the PRESS ARM (8) to the SPRING PIN HOUSING and to the L-BRACKET on the RECEIVING TUBE (13) as shown on FIGURE 9 and DETAIL 9 using the following steps:

- Thread the first 1/4-28 IN. NUT to the bottom of the threaded end of the CABLE. Allow the other 1/4-28 IN. NUT to hang loose on the exposed CABLE until the SPRING PIN ASSEMBLY is attached.
- Securely assemble the SPRING PIN ASSEMBLY to the SPRING PIN BARREL. (!!! IMPORTANT !!! TIGHTEN THE NUT OF THE SPRING PIN ASSEMBLY SECURELY)
- Swing the PRESS ARM (8) up until the SPRING PIN of the PUSH/PULL CABLE engages in one of the adjustment holes.
- Thread the second 1/4-28 IN. NUT onto the threaded end of the CABLE, and cinch the two 1/4-28 IN. NUTS around the flat.
- Use the extra thread on the end of the CABLE to adjust out slack. (!!! DO NOT ADJUST OUT TO FAR !!! ALWAYS ALLOW SPRING PIN ASSEMBLY TO FULLY ENGAGE)

STEP 10

- Securely tighten two 5/32" SET SCREWS (65) and insert two 3 X 2" END CAPS (75) into the open ends of PRESS ARM (8) as shown in FIGURE 10.
- Securely tighten two 5/32" SET SCREWS (65) and insert two 2" SQ. END CAPS (76) into the open ends of PRESS ARM LEVER (9) as shown in FIGURE 10.
- Securely tighten one 3/8 X 1" BOLT (35), one 3/8" WASHER (51), and one 3/8" LOCKNUT (48) to the bottom of ADJUSTMENT SLIDE (6) as shown in FIGURE 10.
- Insert one 1-3/4" SQ. END CAP (77) into the end of ADJUSTMENT SLIDE (6) as shown in FIGURE 10.

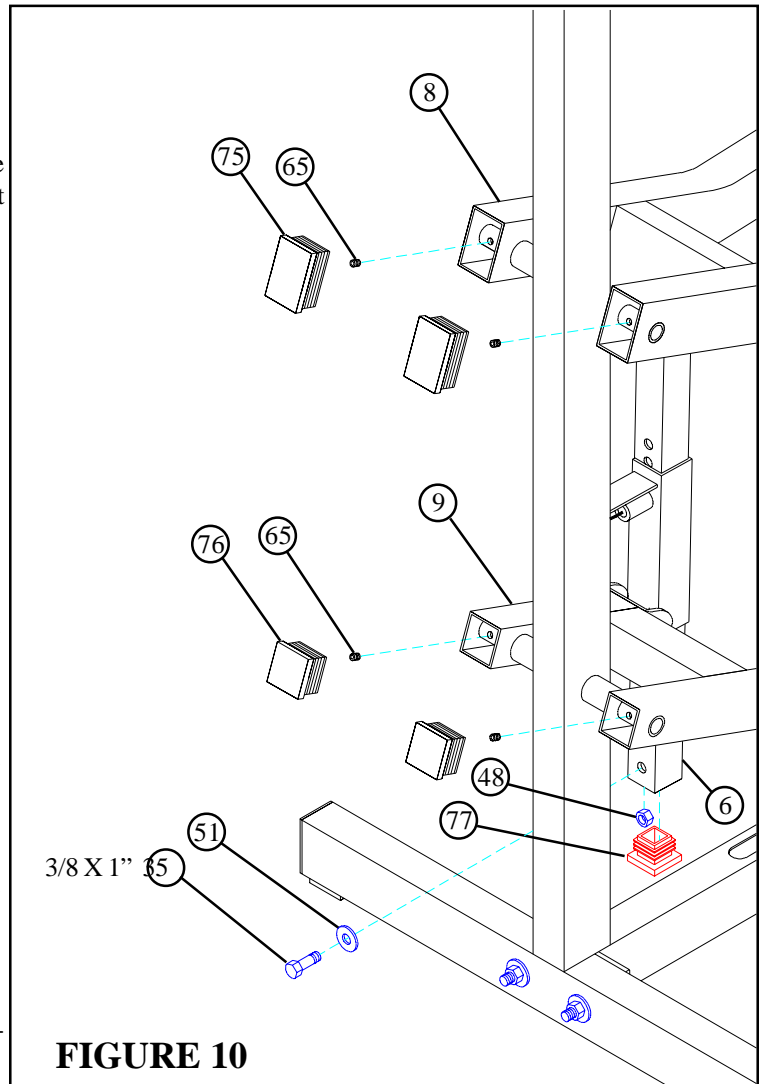
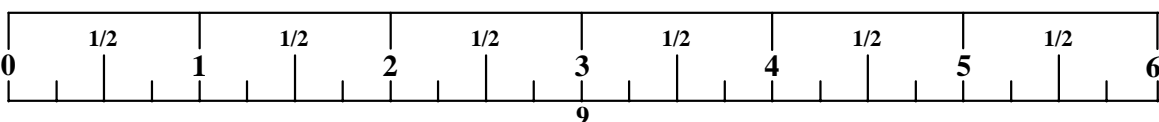
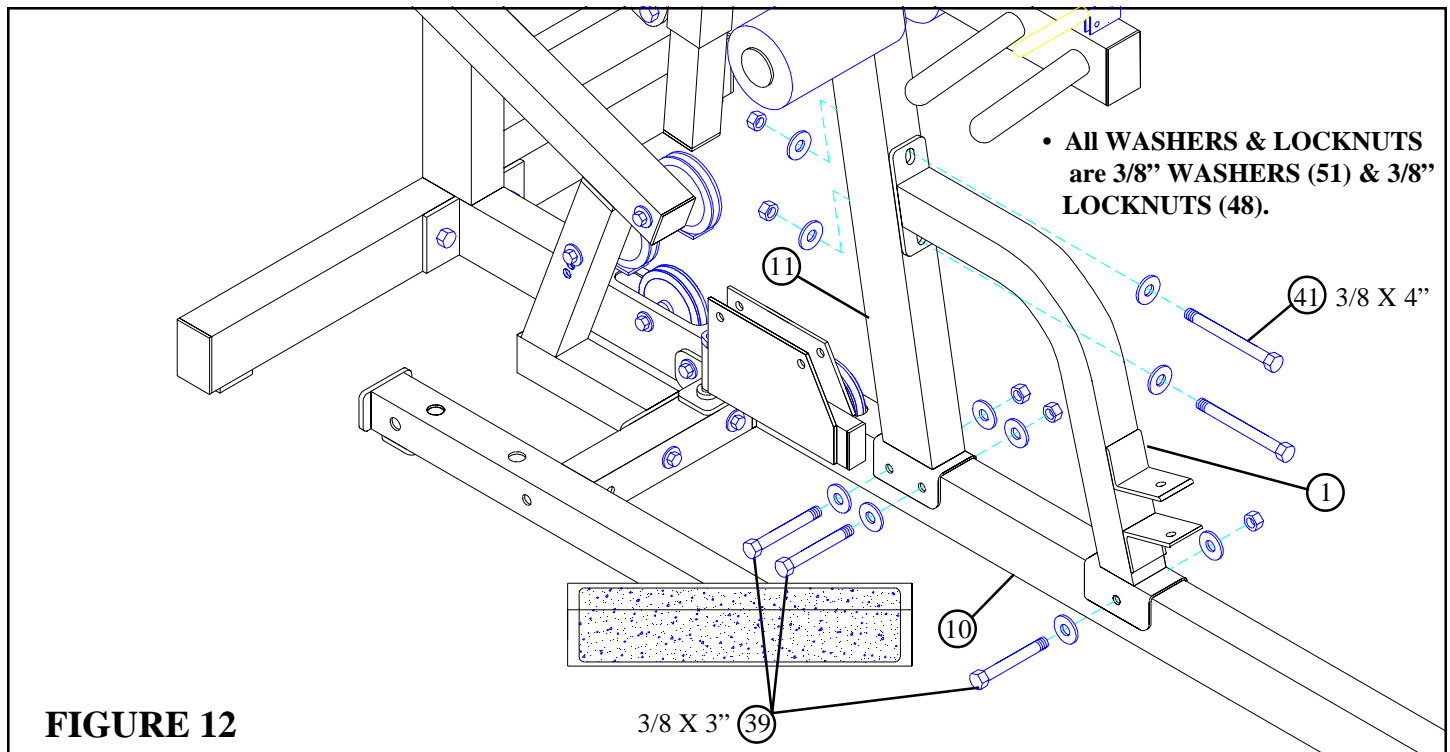
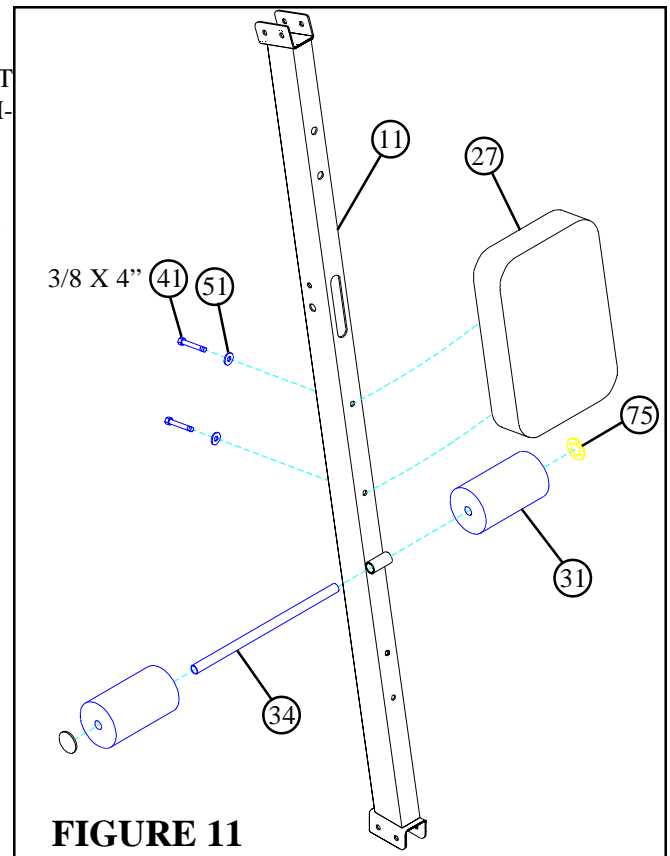

FIGURE 10



STEP 11

- Securely assemble the PEC SEAT PAD (27) to the FRONT UPRIGHT (11) as shown, using two 3/8 X 4" BOLTS (41), and two 3/8" WASHERS (51) as shown in FIGURE 11.
- Assemble two ROLLER PADS (31) to the FRONT UPRIGHT (11) using one 16" TUBE (34), and two STARLOCK COLLARS (75) as shown in FIGURE 11.



STEP 12

- Loosely attach FRONT UPRIGHT (11) to the BASE (10) using two 3/8 X 3" BOLTS (39), four 3/8" WASHERS (51), and two 3/8" LOCKNUTS (48) as shown in FIGURE 12. (**NOTE: Make sure cable is routed under the bolts.**)
- Loosely attach FRAME SUPPORT (1) to the BASE (10) using one 3/8 X 3" BOLT (39), two 3/8" WASHERS (51), and one 3/8" LOCKNUT (48) as shown in FIGURE 12. (**NOTE: Make sure cable is routed under the bolts.**)
- Loosely attach FRAME SUPPORT (1) to the FRONT UPRIGHT (11) using two 3/8 X 4" BOLTS (41), four 3/8" WASHERS (51), and two 3/8" LOCKNUTS (48) as shown in FIGURE 12.

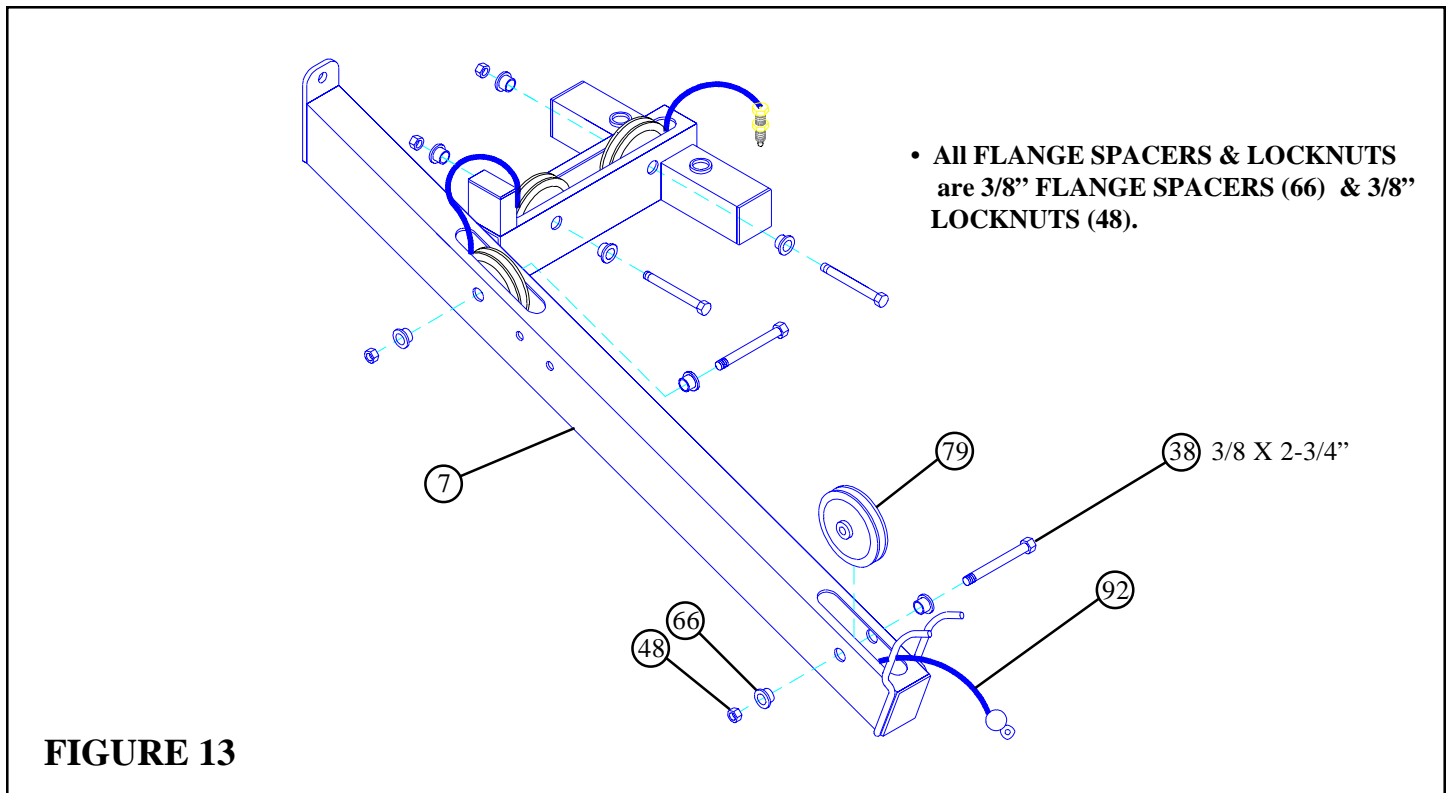

STEP 13

- Route the threaded end of LAT CABLE (92) through the TOP BOOM (7) as shown in FIGURE 13.
- **Loosely** assemble four 3-1/2" PULLEYS (79) to the slots in TOP BOOM (7) using four 3/8 X 2-3/4" BOLTS (38), eight 3/8" FLANGE SPACERS (66), and four 3/8" LOCKNUTS (48) as shown in FIGURE 13. (NOTE: Make sure the cable is routed under all the pulleys.)

STEP 14

- Snap two WEIGHT PLATE BUSHINGS (47) each, into the PARABODY side of fifteen WEIGHT PLATES (74) as shown in FIGURE 14.

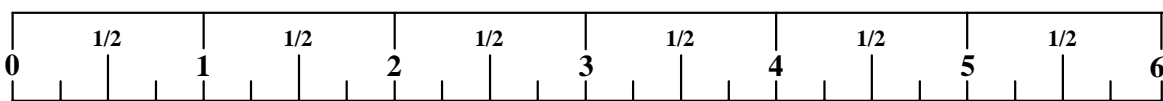
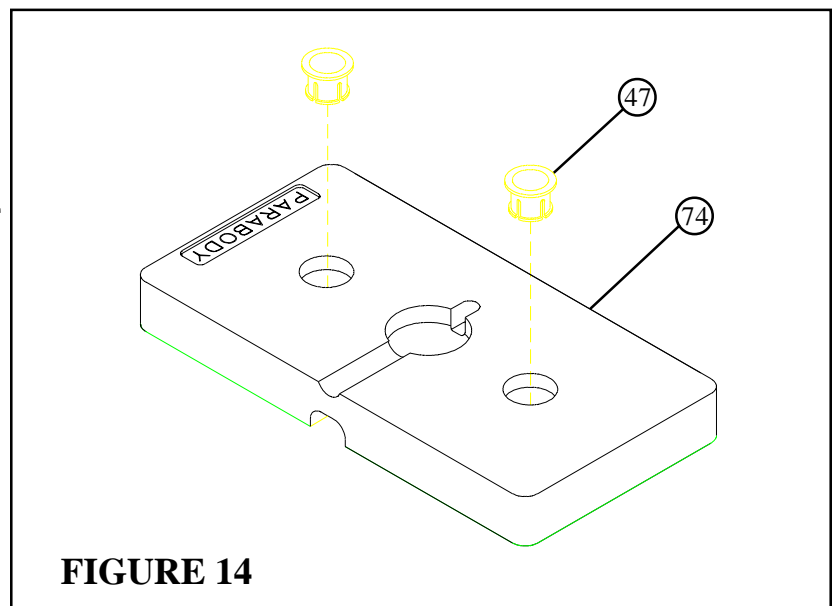

STEP 15

- Securely assemble the WEIGHT STACK SHAFT (80) to the HEAD PLATE (81) using one 3/8 X 1-1/4" BOLT (46) and one 3/8" WASHER (51).
- Insert two GUIDE RODS (33) into the WEIGHT STACK BASE (3) as shown on FIGURE 15. (**NOTE: Lubricate GUIDE RODS (33) with silicon or teflon spray available at most hardware stores.**)
- Slide two WEIGHT STACK SPACERS (34), two 3/4" WASHERS (53), and two WEIGHT STACK CUSHIONS (88) - **IN THAT ORDER** - down over the GUIDE RODS (33).
- Using **EXTREME CARE** slide all fifteen WEIGHT PLATES (74) down over the GUIDE RODS (33) on to the WEIGHT STACK CUSHIONS (88). Make sure that the keyholes of the WEIGHT PLATES (74) are all facing the right way.
- Slide the head plate assembly down over the GUIDE RODS (33) onto the weight stack.
- Insert two CAP PLUGS (89) into the top ends of the GUIDERODS (33).
- Attach the WEIGHT STACK LABELS (94) to the weight stack. Also insert the WEIGHT STACK PIN (57) into the first WEIGHT PLATE (74) of the weight stack.

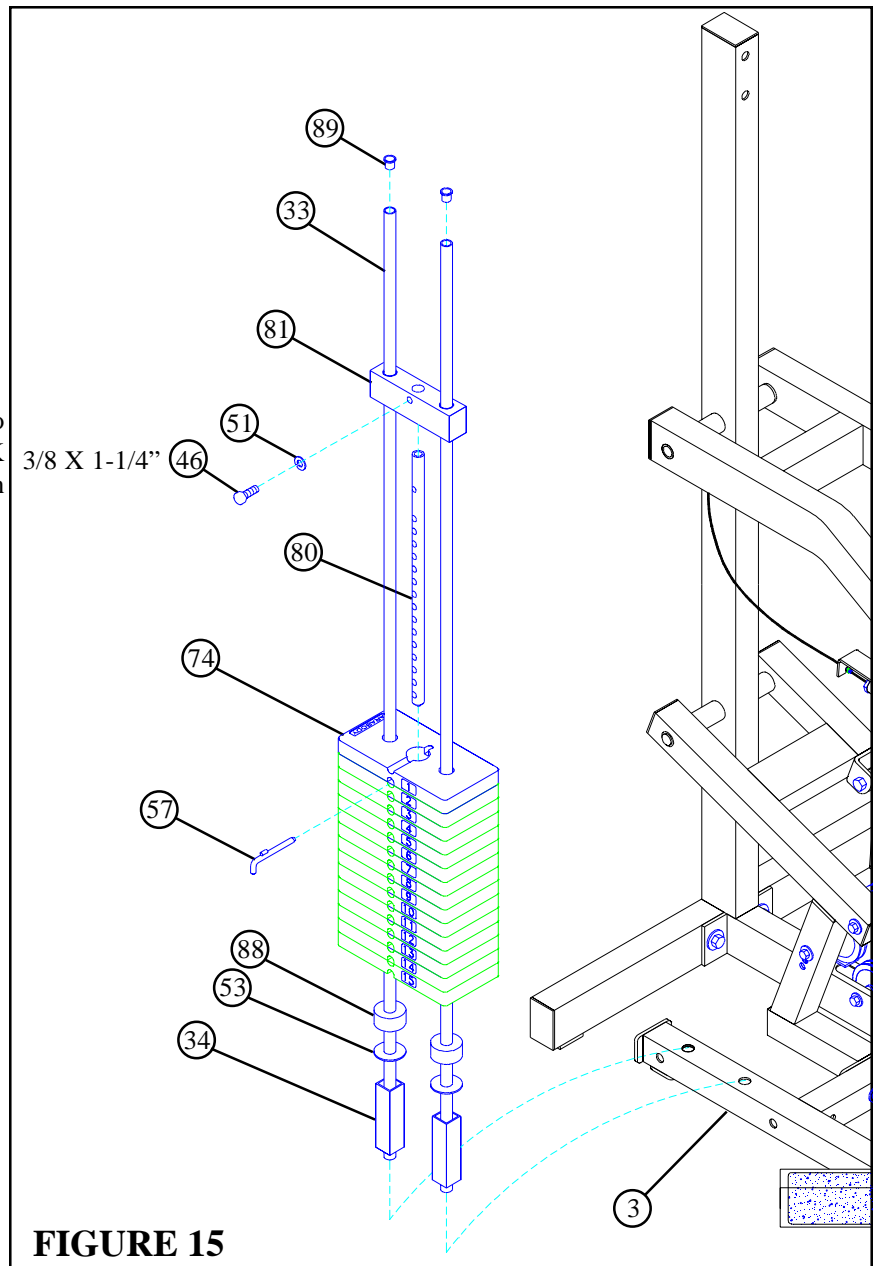

FIGURE 15

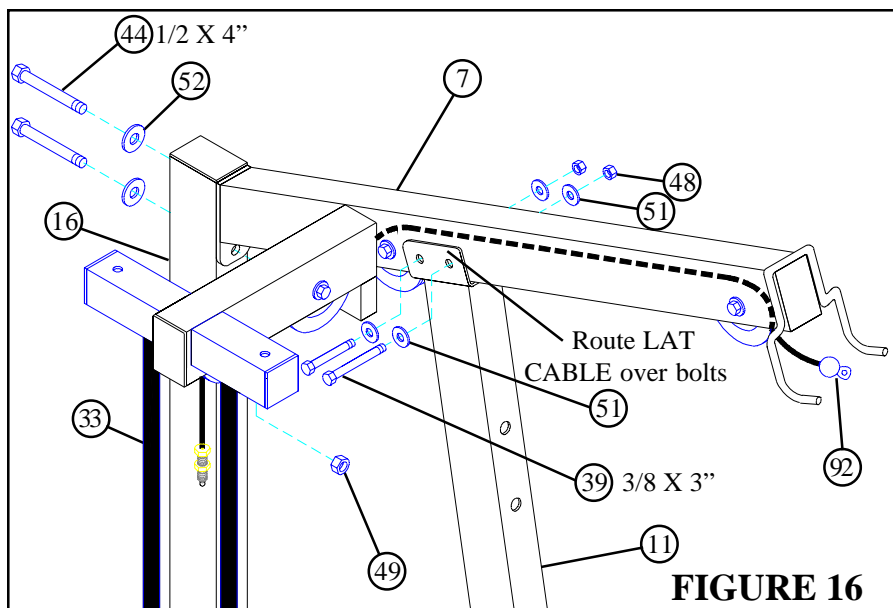

FIGURE 16

STEP 16

- Swing the GUIDE RODS (33) under the TOP BOOM (7) as shown on FIGURE 16.
- Loosely assemble the TOP BOOM (7) to the REAR UPRIGHT (16) using two 1/2 X 4" BOLTS (44), two 1/2" WASHERS (52), and one 1/2" LOCKNUT (49).
- Loosely assemble the TOP BOOM (7) to the FRONT UPRIGHT (11) using two 3/8 X 3" BOLTS (39), four 3/8" WASHERS (51), and two 3/8" LOCKNUTS (48). Make sure LAT CABLE (92) is routed **OVER** top of bolts.

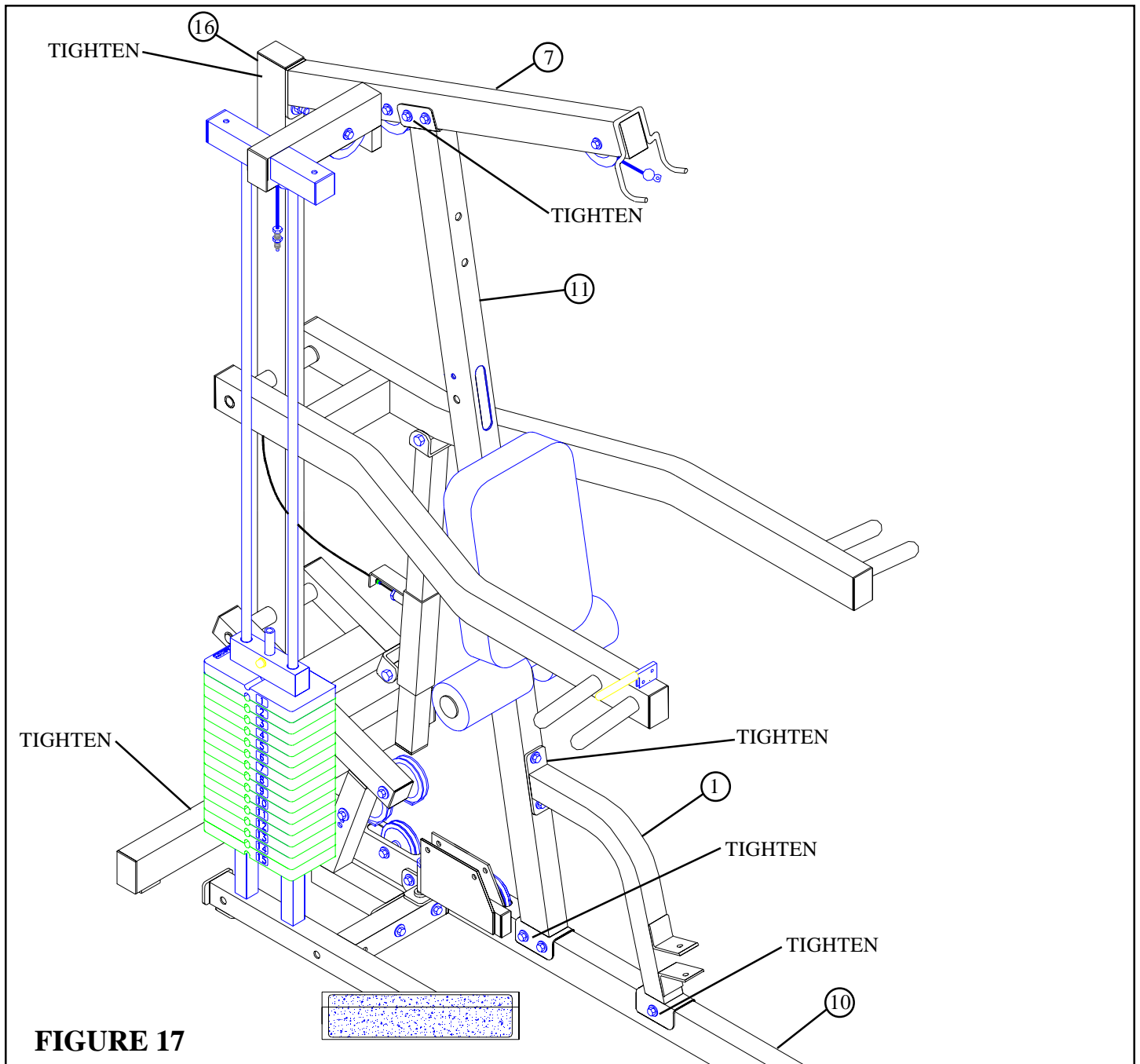

FIGURE 17

STEP 17

Securely tighten all loose frame connections made to this point.

Tighten the:

- REAR UPRIGHT (16) to the BASE (10).
- FRONT UPRIGHT (11) to the BASE (10).
- FRAME SUPPORT (1) to the BASE (10) and the FRONT UPRIGHT (11).
- TOP BOOM (7) to the REAR UPRIGHT (16).
- and the TOP BOOM (7) to the FRONT UPRIGHT (11).

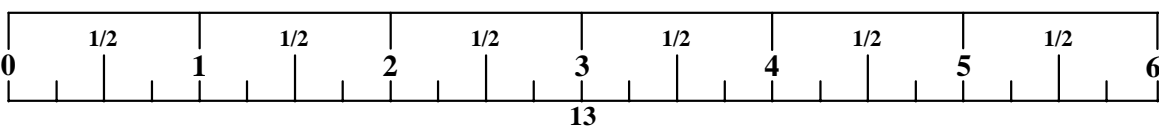

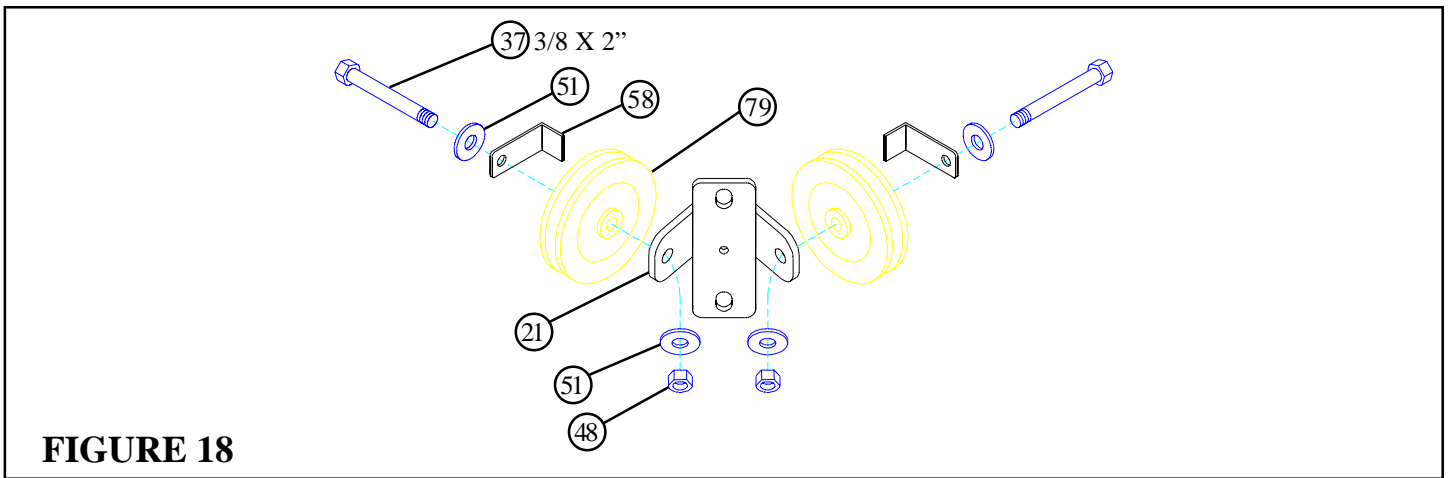

FIGURE 18

STEP 18

- Loosely assemble two 3-1/2" PULLEYS (79) and two 2-3/8" CABLE RETAINING CLIPS (58) to the CENTER PULLEY BRACKET (21) using two 3/8 X 2" BOLTS (37), four 3/8" WASHERS (51), and two 3/8" LOCKNUTS (48). See FIGURE 18. (NOTE: This connection will be tightened after the cable has been routed.)

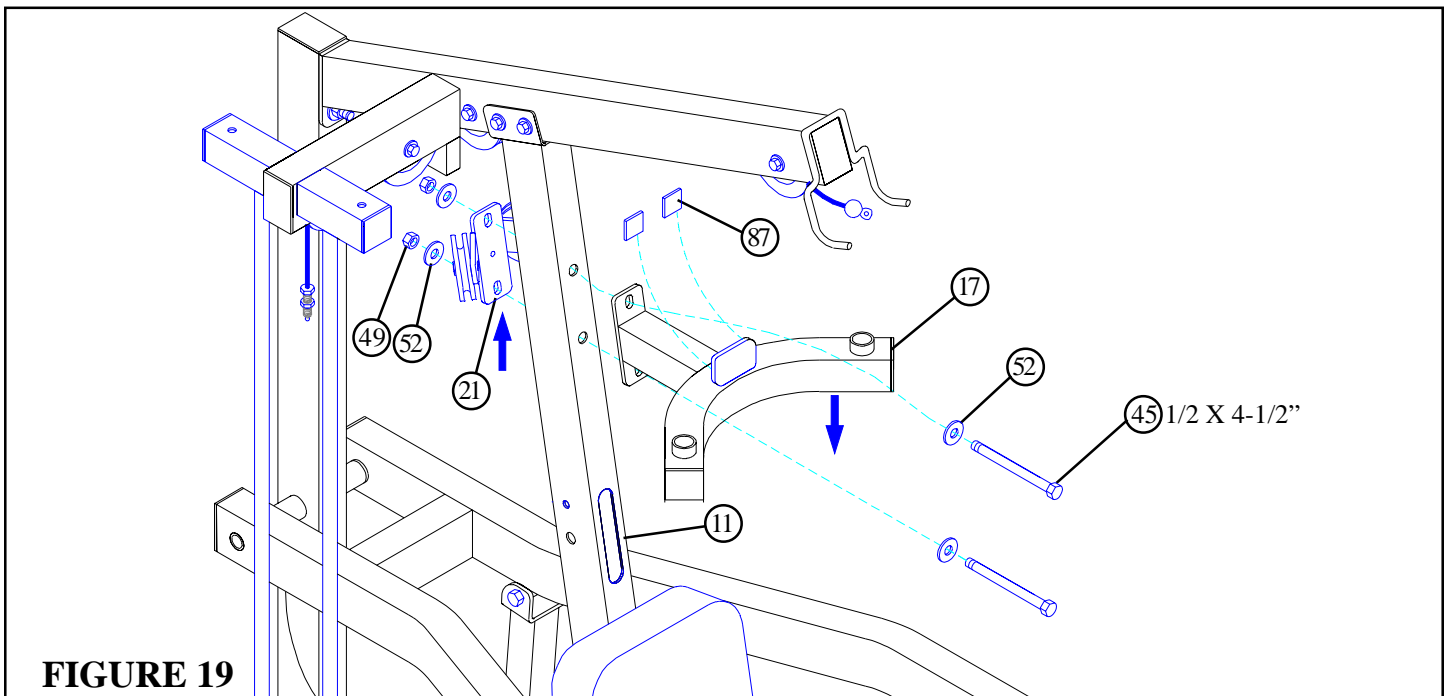

FIGURE 19

STEP 19

- Securely assemble the BEARING HOUSING (17) and the CENTER PULLEY BRACKET (21) to the FRONT UPRIGHT (11) as shown in FIGURE 19, using two 1/2 X 4-1/2" BOLTS (45), four 1/2" WASHERS (52), and two 1/2" LOCKNUTS (49). (NOTE: The connector plates on the BEARING HOUSING (17) and the CENTER PULLEY BRACKET (21) have slotted holes. Shift the BEARING HOUSING (17) down as far as possible and the CENTER PULLEY BRACKET (21) up as far as possible before tightening.)
- Attach two 1" X 1" GLIDES (87) to plate on the BEARING HOUSING (17) as shown.

STEP 20

- Assemble two 3/4" THRUST WASHERS (68) and two PEC CAMS (24) to the LEFT (20) & RIGHT (19) PEC ARMS, as shown on FIGURE 20.
- Insert four 3/4" FLANGE BEARINGS (69) into the bushings of the BEARING HOUSING (17).
- Insert the LEFT (20) & RIGHT (19) PEC ARMS through the 3/4" FLANGE BEARINGS (69) in the BEARING HOUSING (17) on their respective side as shown, and secure them in place with two 3/4" STARLOCK COLLARS (73).
- Slide two PEC DEC ROLLER PADS (32) onto the LEFT (20) & RIGHT (19) PEC ARMS until the ROLLER PAD (32) is flush with the bottom of the pec arms.
- **(NOTE: If a lubricant is required coat the inside of the ROLLER PAD (32) with rubbing alcohol or water. Also, rotating the pad while pushing up will help ease assembly.)**
- Securely assemble two 3/8" SPRING PIN ASSEMBLIES (71) to the spring pin barrels of the PEC ARMS (19 & 20).

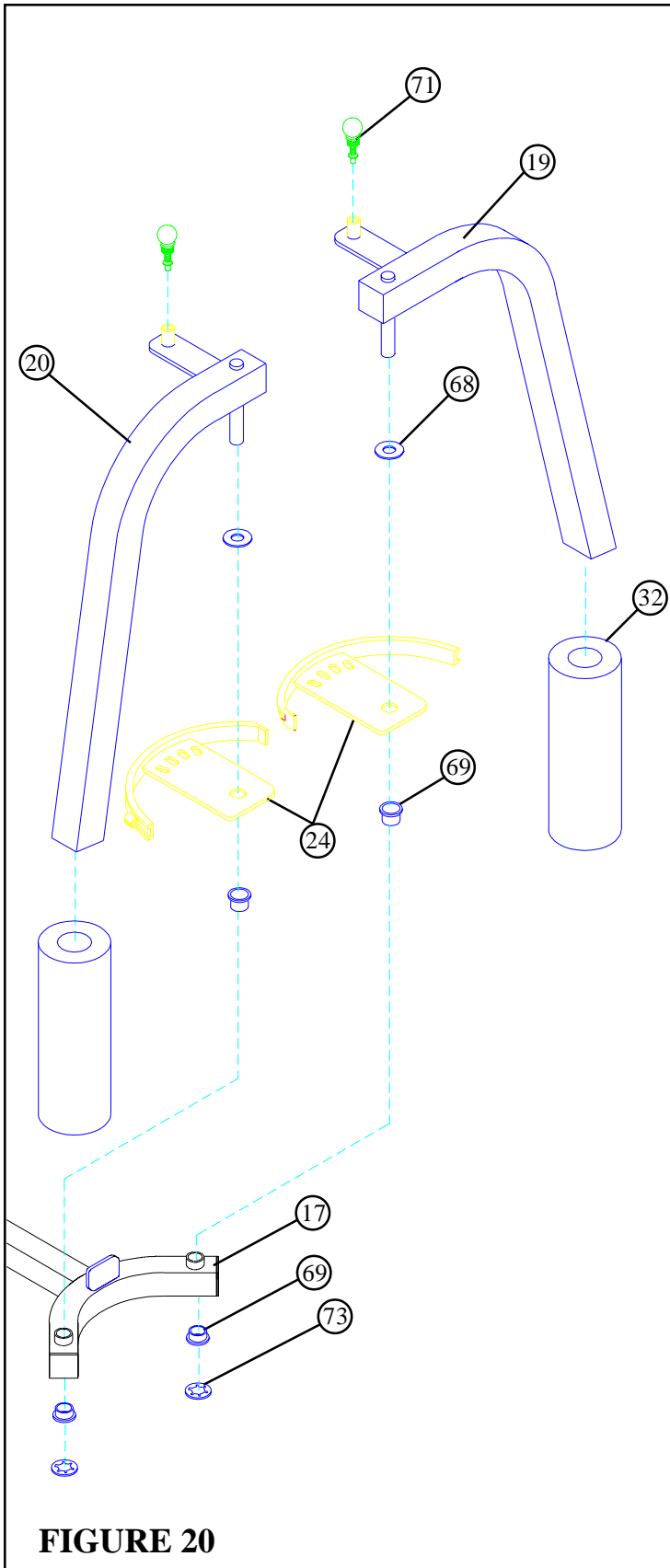
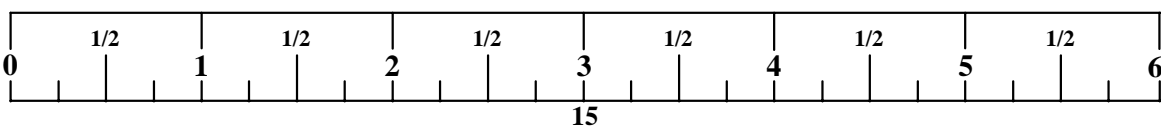

FIGURE 20



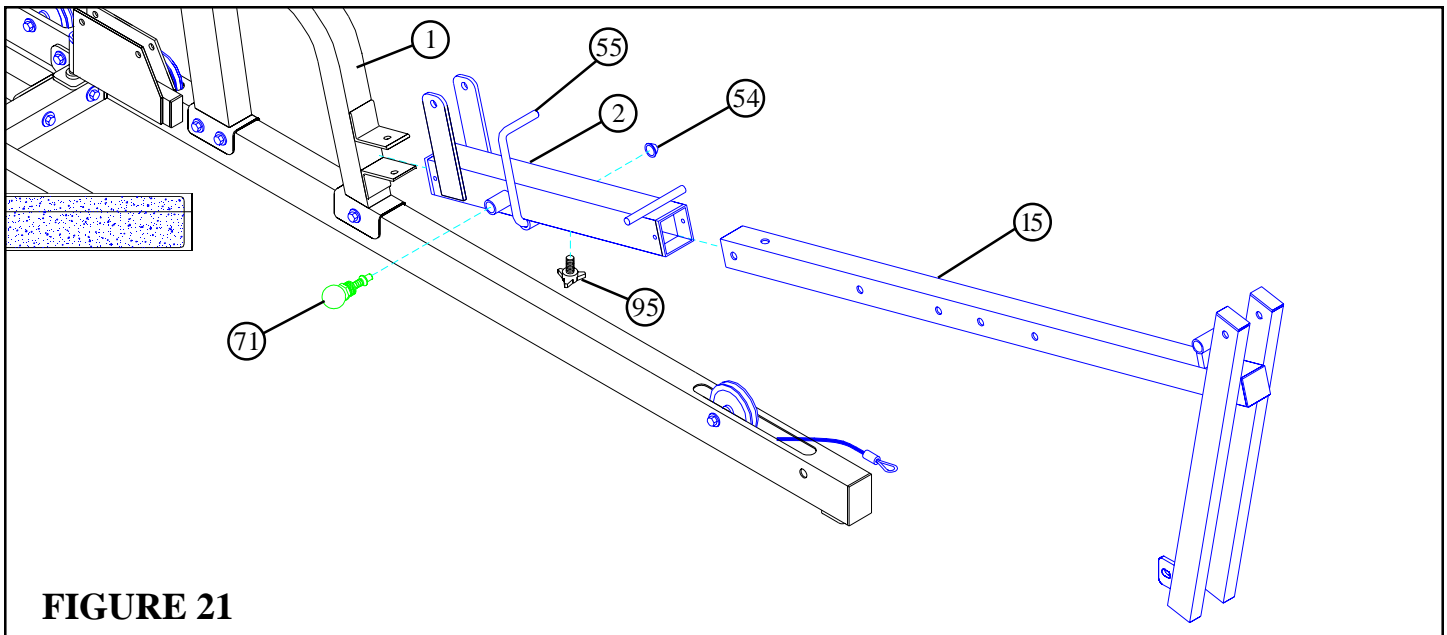

FIGURE 21

STEP 21

- Slide the 1/2" DIA U-PIN (55) through the bushing in the WOLFF SLEEVE (2) then force 1/2" PAL NUT (54) over end of 1/2" DIA U-PIN (55).
- Slide the WOLFF SLEEVE (2) over the BENCH FRAME (15). (**NOTE: Make sure the spring pin barrel is facing as shown in FIGURE 21.**)
- Slide the BENCH FRAME (15) between the angles on the FRAME SUPPORT (1).
- Securely assemble one 3/8" SPRING PIN ASSEMBLY (71) and one THUMBSCREW (95) to the WOLFF SLEEVE (2).

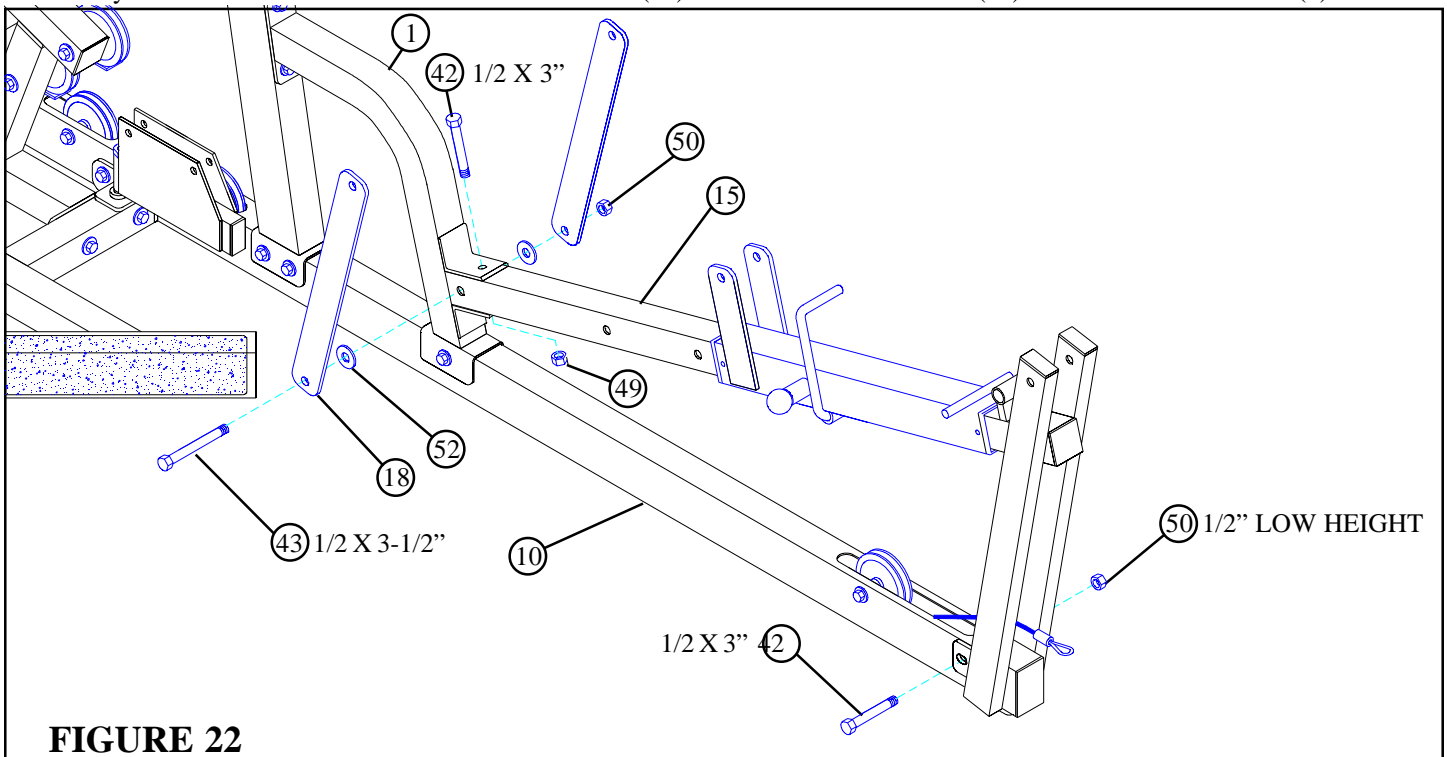

FIGURE 22

STEP 22

- Securely fasten BENCH FRAME (15) to the BASE (10) using one 1/2 X 3" BOLT (42) and one 1/2" LOW HEIGHT LOCKNUT (50).
- Securely attach BENCH FRAME (15) to the FRAME SUPPORT (1) using one 1/2" X 3" BOLT (42) and one 1/2" LOCKNUT (49).
- Attach two 2 X 16-1/2" PLATES (18) to the BENCH FRAME (15) using one 1/2 X 3-1/2" BOLT (43), two 1/2" WASHERS (52), and one 1/2" LOCKNUT (49). Make sure 1/2" WASHER (52) is on inside of plate as shown on FIGURE 22. (**NOTE: Securely tighten, then back nut off 1/4 turn to allow the 2 X 16-1/2" PLATES (18) to rotate freely.**)

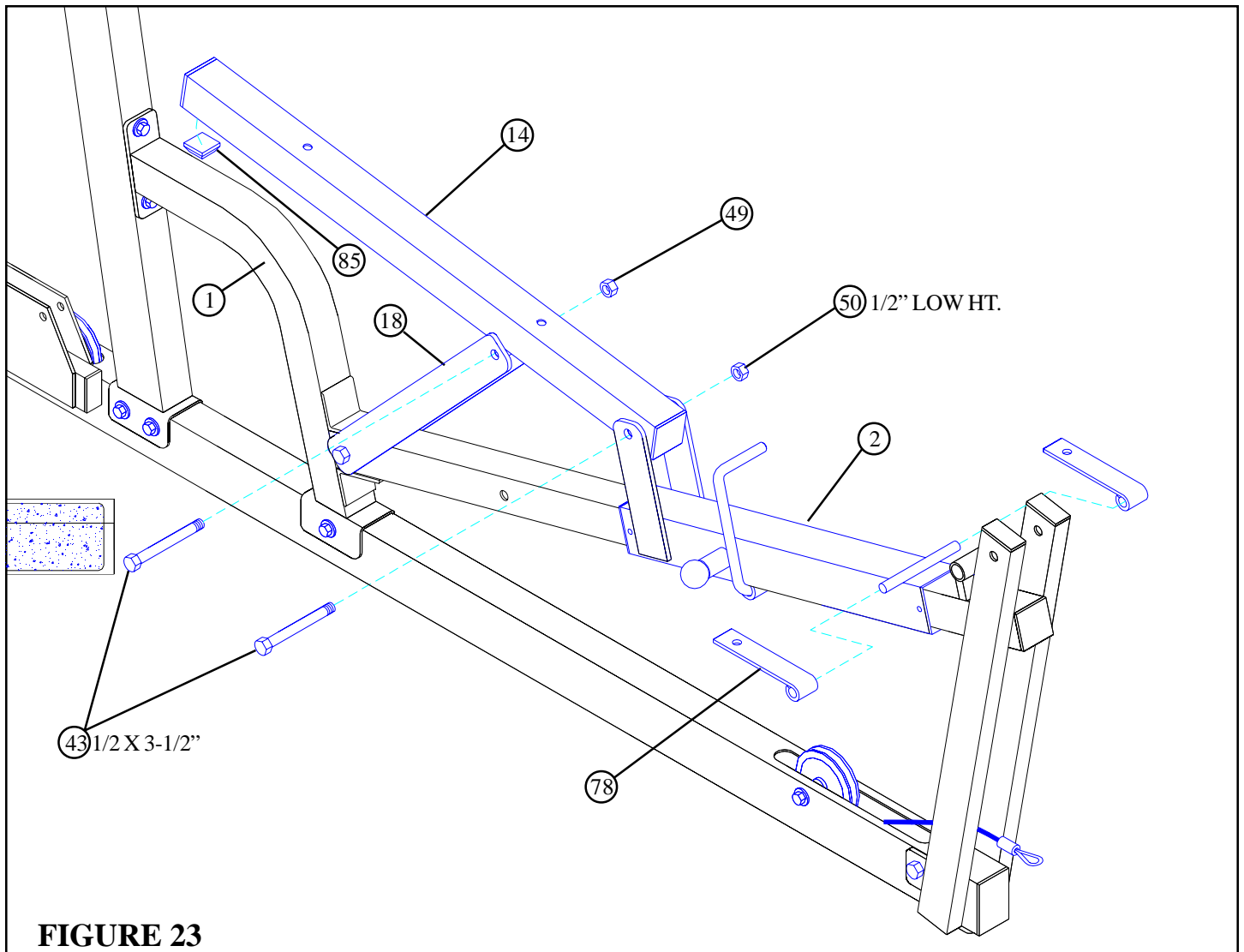
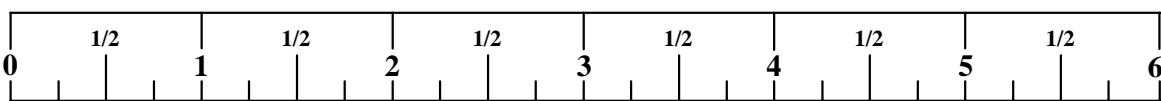

FIGURE 23

STEP 23

- Attach WOLFF SLEEVE (2) to the BACK PAD SUPPORT (14) using one 1/2 X 3-1/2" BOLT (43) and one 1/2" LOW HEIGHT LOCKNUT (50). (NOTE: Securely tighten, then back nut off 1/4 turn to allow the BACK PAD SUPPORT (14) to rotate freely.) See FIGURE 23.
- Attach both 2 X 16-1/2" PLATES (18) to the bushing on the BACK PAD SUPPORT (14) using one 1/2 X 3-1/2" BOLT (43) and one 1/2" LOCKNUT (49). (NOTE: Securely tighten, then back nut off 1/4 turn to allow the 2 X 16-1/2" PLATES (18) to rotate freely.) See FIGURE 23.
- Slide one HINGE TAB (78) on each side of shaft on WOLFF SLEEVE (2). See FIGURE 23.
- Stick one 1-1/4" RUBBER BUMPER (85) on the BACK PAD SUPPORT (14) approximately 1/2" from the end of BACK PAD SUPPORT (14).



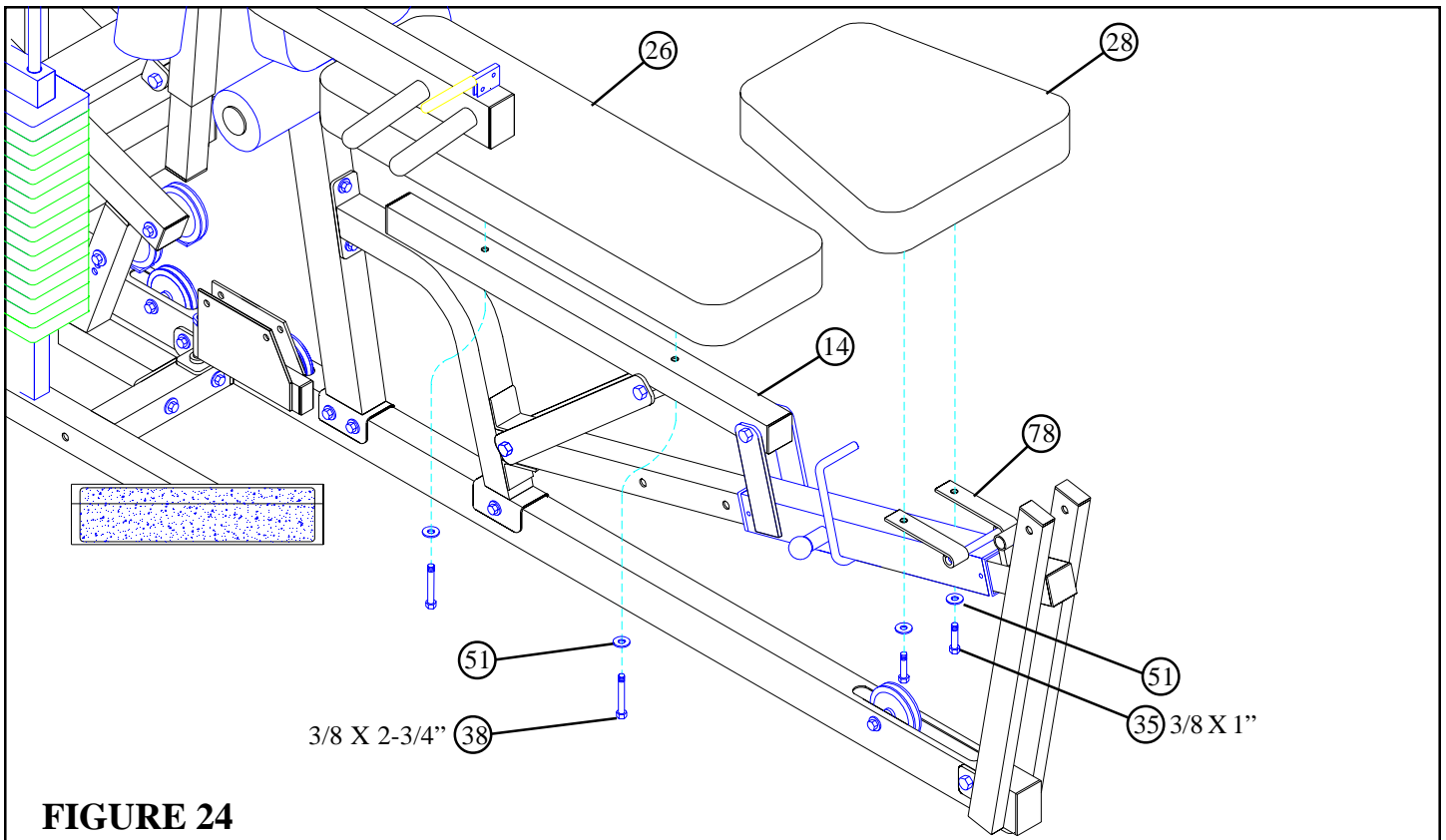

FIGURE 24

STEP 24

- Securely attach BACK SEAT PAD (26) to BACK PAD SUPPORT (14) using two 3/8 X 2-3/4" (38) and two 3/8" WASHERS (51).
- Securely attach LEG SEAT PAD (28) to HINGE TABS (78) using two 3/8 X 1" (35) and two 3/8" WASHERS (51) as shown in FIGURE 24.

STEP 25

Assemble the LEG CURL/EXTENSION (4) to the BENCH FRAME (15) using the following steps:

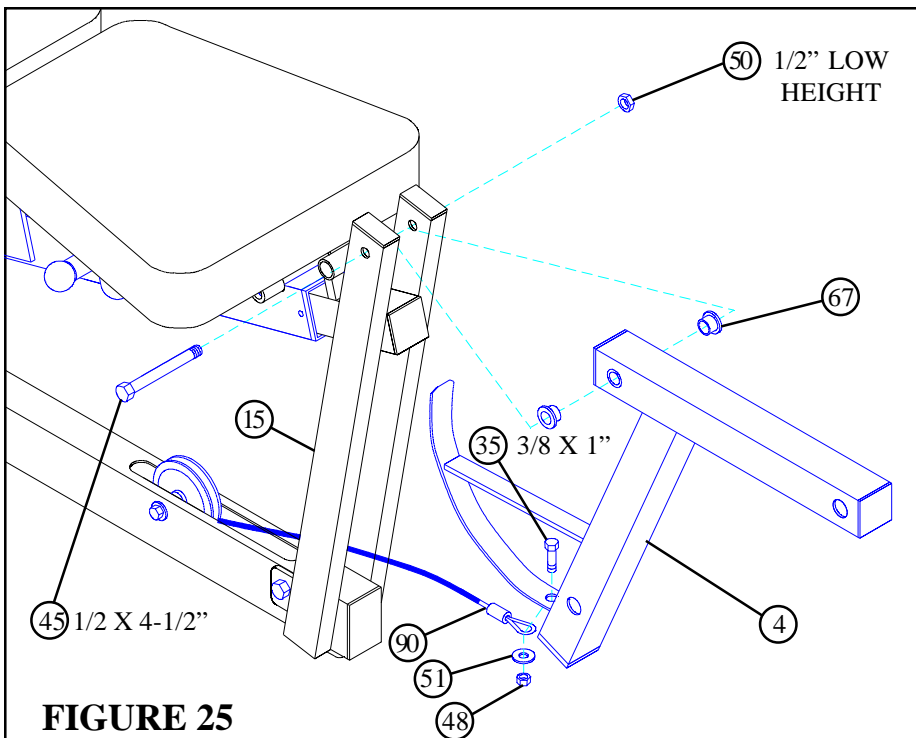

FIGURE 25

- Insert two 1/2" FLANGE BEARINGS (67) into the LEG CURL/EXTENSION (4).
- Assemble the LEG CURL/EXTENSION (4) to the BENCH FRAME (15) using one 1/2 X 4-1/2" (45) and one 1/2" **LOW HEIGHT** LOCKNUT (50). (**NOTE:** Securely tighten, then back nut off 1/4 turn to allow the LEG CURL/EXTENSION (4) to rotate freely.)
- Securely fasten 227" CABLE (90) to the LEG CURL/EXTENSION (4) using one 3/8 X 1" BOLT (35), one 3/8" WASHER (51), and one 3/8" LOCKNUT (48) as shown in FIGURE 25.

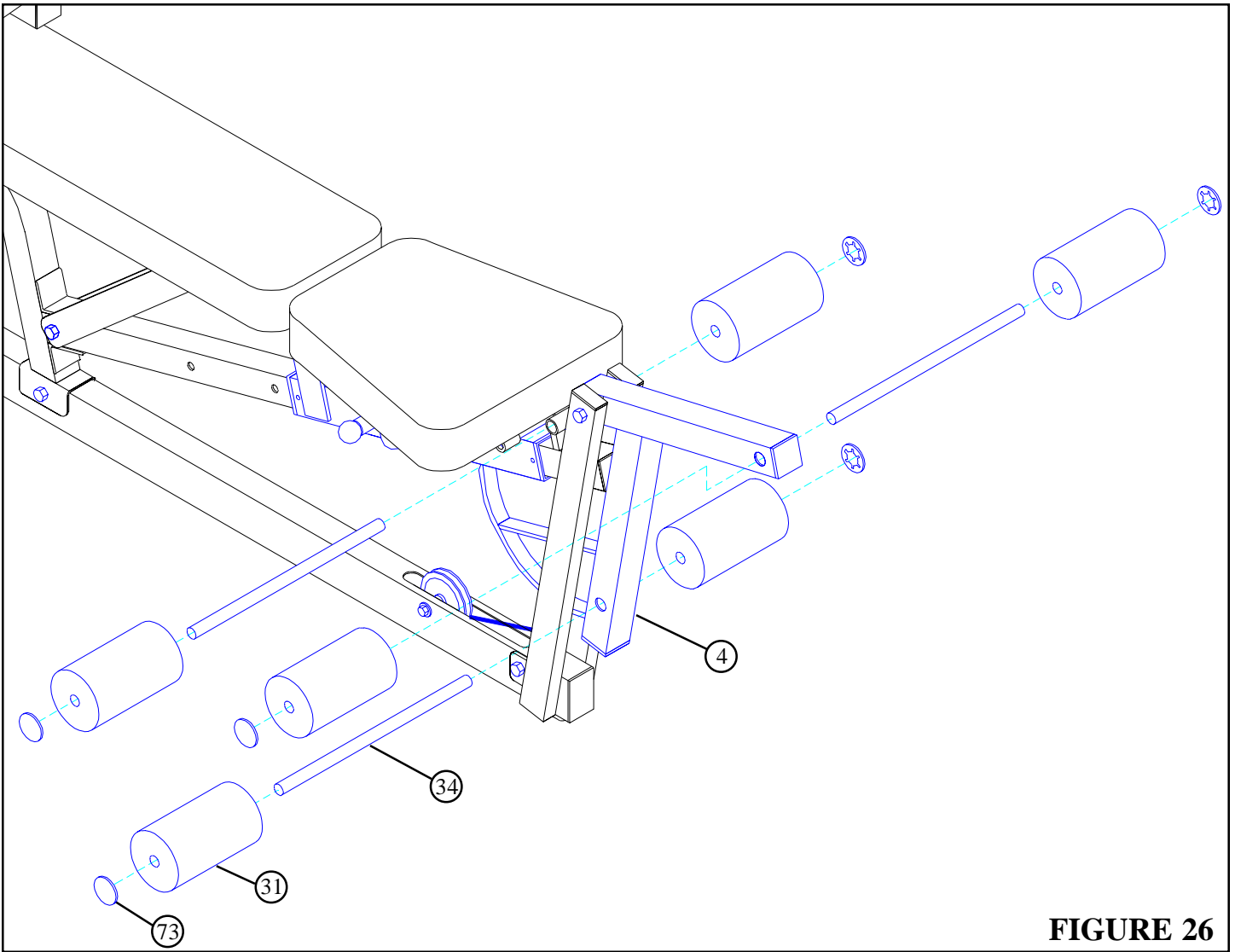

FIGURE 26

STEP 26

- Assemble four ROLLER PADS (31) to the LEG CURL/EXTENSION (4) as shown on FIGURE 26 using two 16" TUBES (34) and four STARLOCK COLLARS (73).
- Assemble two ROLLER PAD (31) to the bushing on the BENCH FRAME (15) as shown on FIGURE 26 using one 16" TUBE (34) and two STARLOCK COLLAR (73).

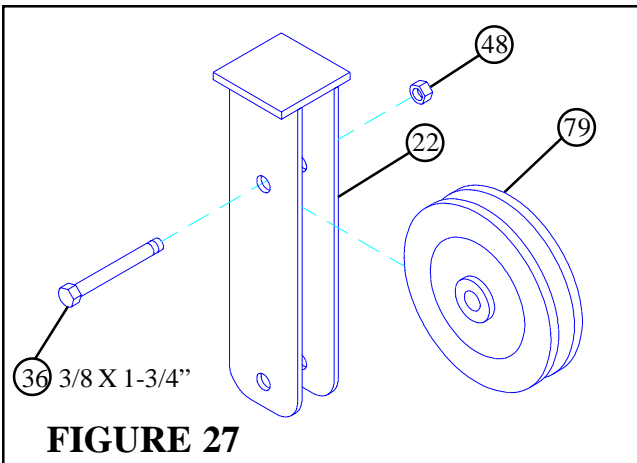
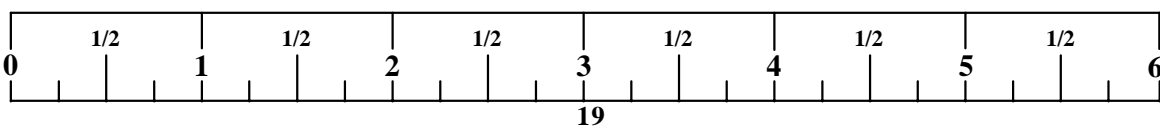

FIGURE 27

STEP 27

- Assemble one 3-1/2" PULLEY (79) to the FLOATING PULLEY BRACKET (22) using one 3/8 X 1-3/4" BOLT (36) and one 3/8" LOCKNUT (48) as shown in FIGURE 27.



CABLE GUIDE

LEG EXT. CABLE (90)

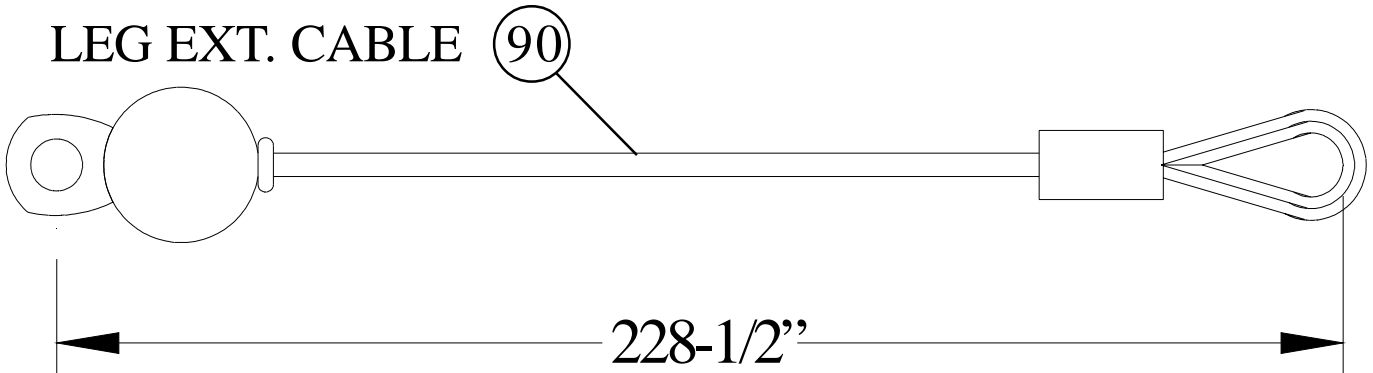

AB CABLE (91)

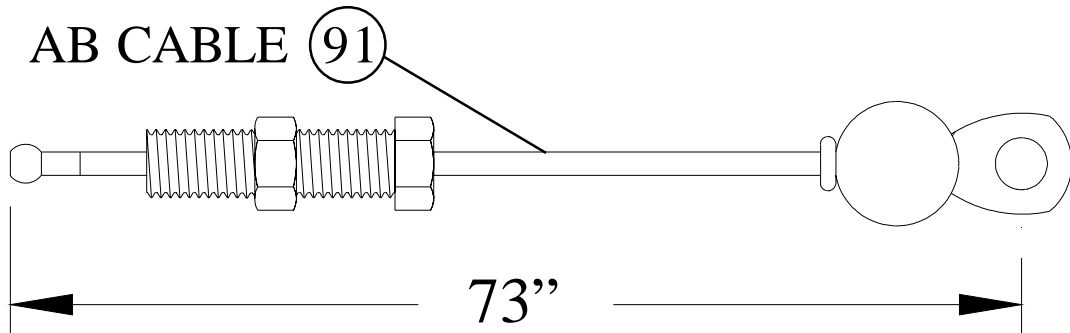

LAT CABLE (92)

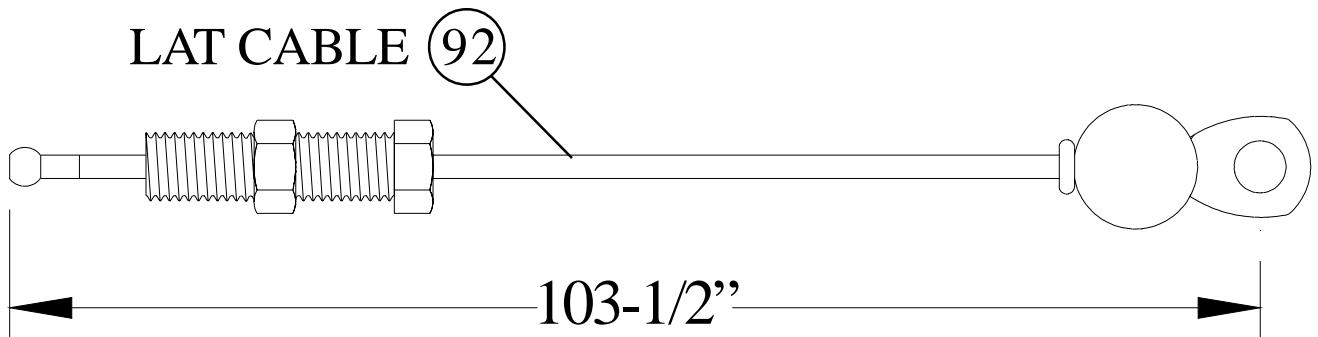

PEC DEC CABLE (93)

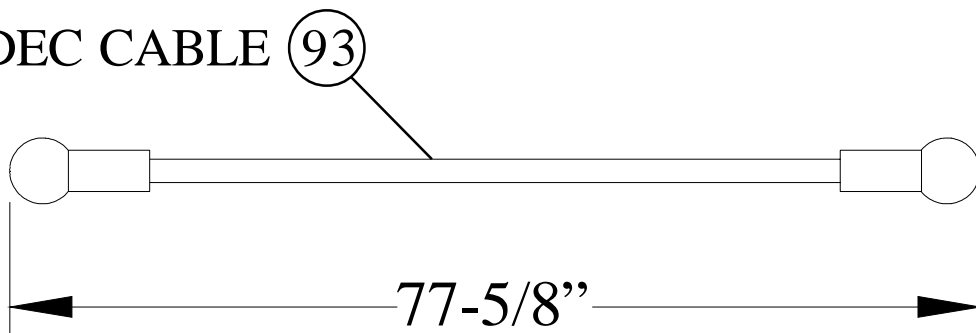

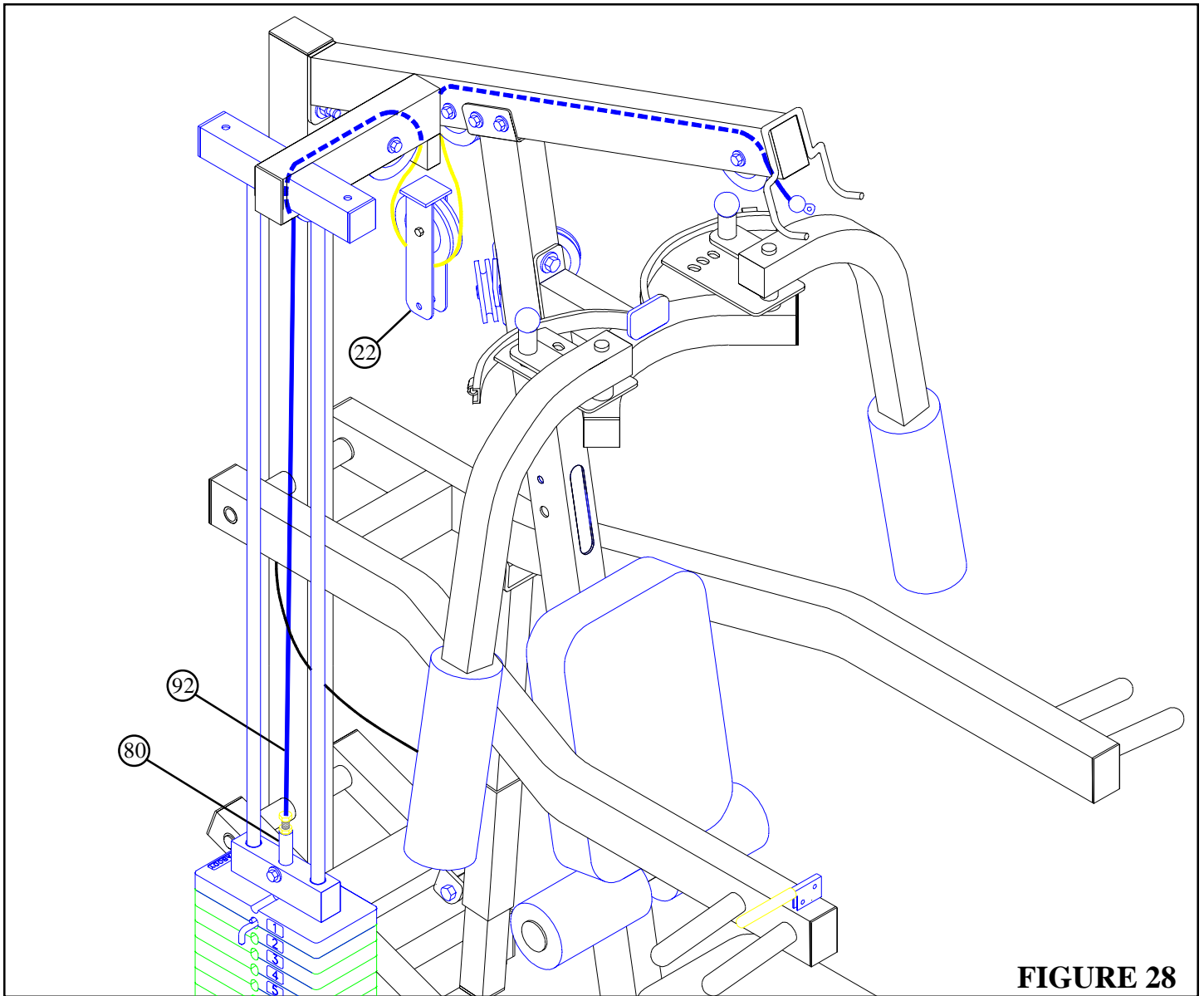

FIGURE 28

STEP 28

- Loop LAT CABLE (92) around pulley in FLOATING PULLEY BRACKET (22) as shown in FIGURE 27.
- Screw the threaded end of LAT CABLE (92) into the end of the WEIGHT STACK SHAFT (80) until the FLOATING PULLEY BRACKET (22) firmly contacts the end cap on the TOP BOOM (7) and the CABLE (92) slightly pulls on the HEAD PLATE (81). Tighten the jam nut securely. See FIGURE 28.

STEP 29

- Assemble one 3-1/2" PULLEY (79) to the **other** FLOATING PULLEY BRACKET (22) using one 3/8 X 1-3/4" BOLT (36) and one 3/8" LOCK-NUT (48) as shown in FIGURE 29.
- Attach two 1" X 1" GLIDES (87) to the bottom of the **second** FLOATING PULLEY BRACKET (22) as shown.

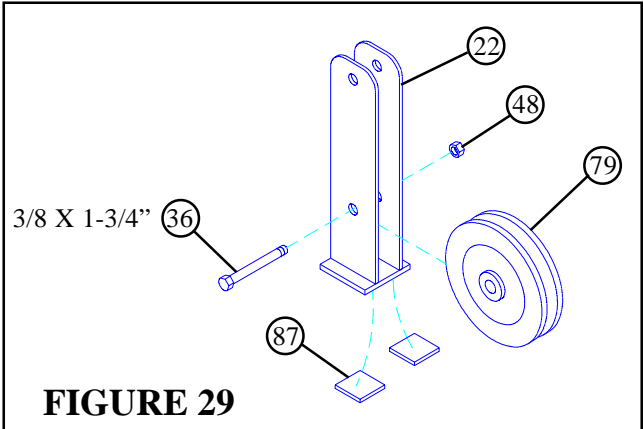
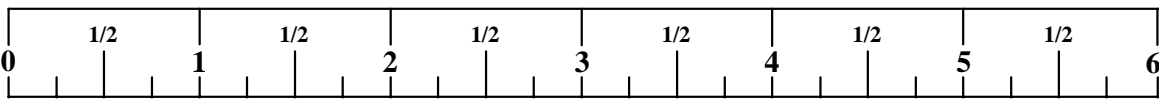
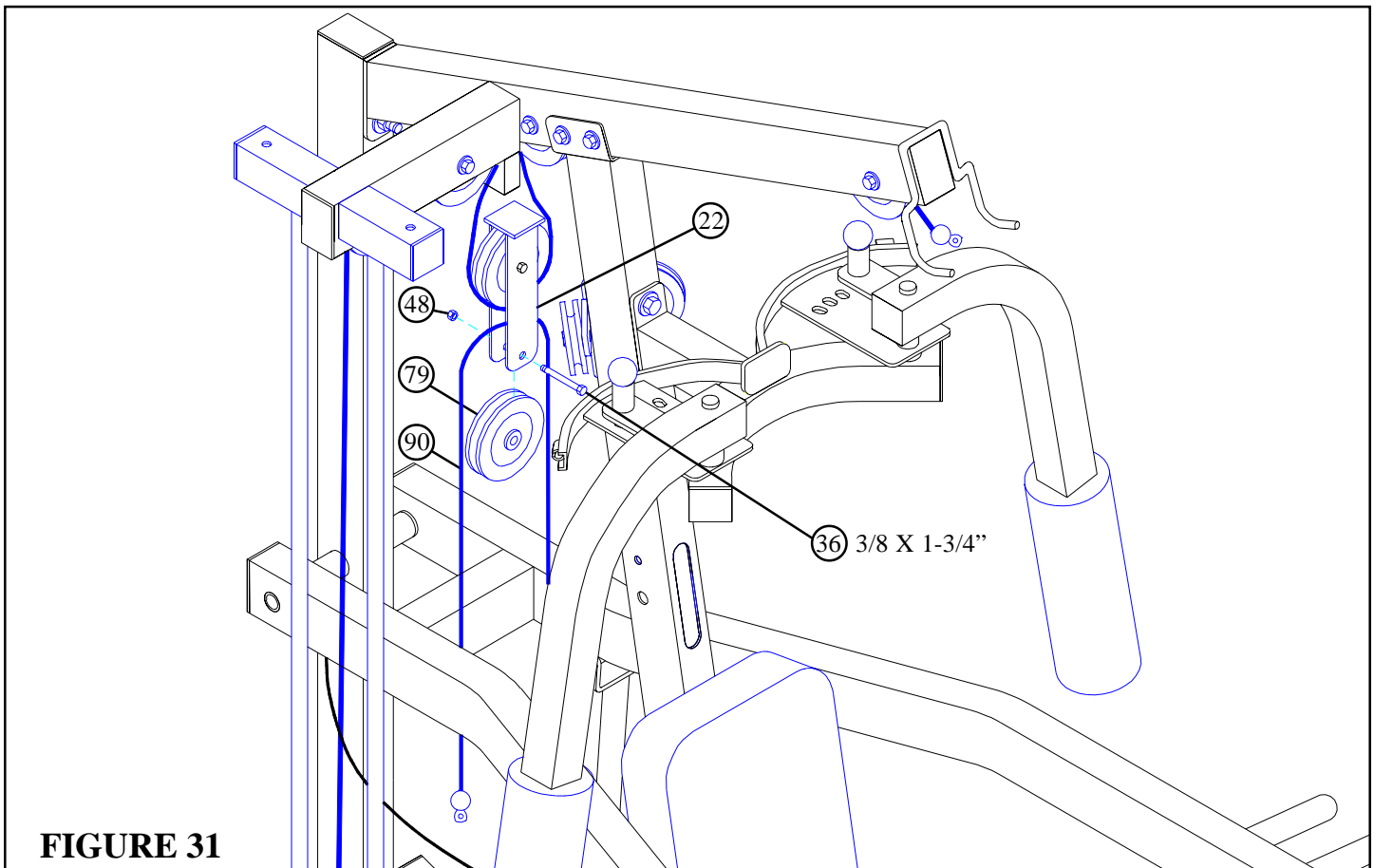
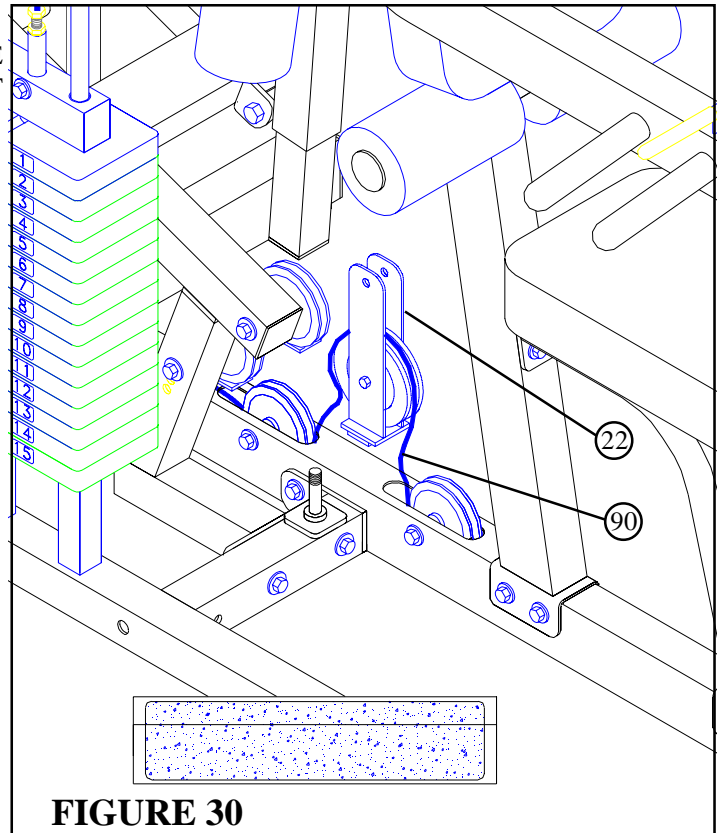

FIGURE 29



STEP 30

- Loop LEG EXT. CABLE (90), previously installed in BASE (10), around pulley in lower FLOATING PULLEY BRACKET (22) as shown in FIGURE 30.



STEP 31

- Assemble one 3-1/2" PULLEY (79) around the LEG EXT. CABLE (90) and to the upper FLOATING PULLEY BRACKET (22) using one 3/8 X 1-3/4" BOLT (36) and one 3/8" LOCKNUT (48) as shown in FIGURE 31.

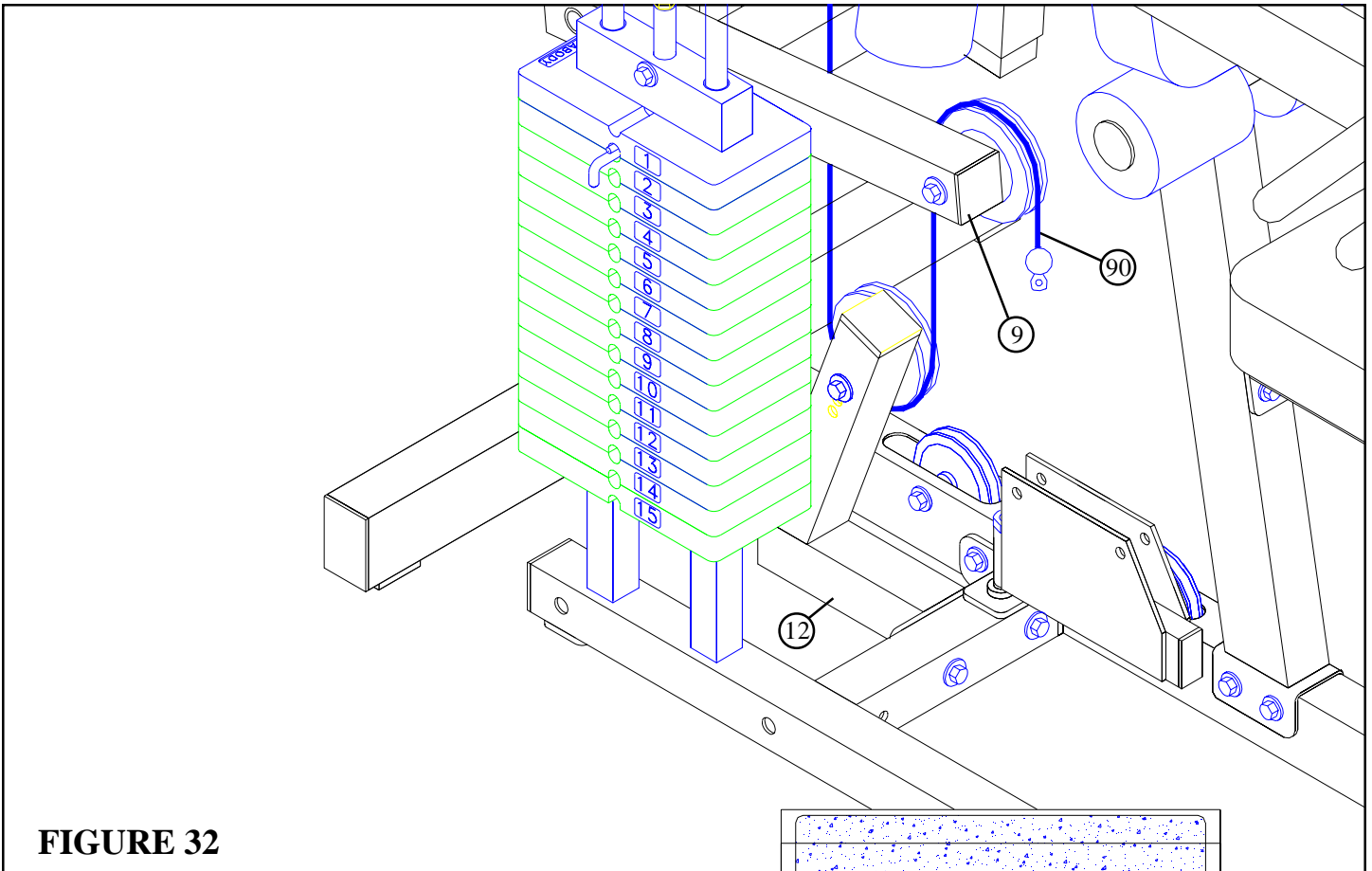

FIGURE 32

STEP 32

- Route ball end of LEG EXT. CABLE (90) under pulley and cable retaining clip on LEVER STOP (12) as shown in FIGURE 32. (NOTE: The bolt holding pulley and cable retaining clip may need to be loosened to align cable retaining clip with cable.)
- Route ball end of LEG EXT. CABLE (90) under pulley and cable retaining clip on PRESS ARM LEVER (9). (NOTE: The bolt holding pulley and cable retaining clip may need to be loosened to align cable retaining clip with cable.)

STEP 33

- After routing ball end of LEG EXT. CABLE (90) through SWIVEL PULLEY BRACKET (23), attach two 3-1/2" PULLEYS (79) using two 3/8" X 2" BOLTS (37) and two 3/8" LOCK-NUTS (48). See FIGURE 33.

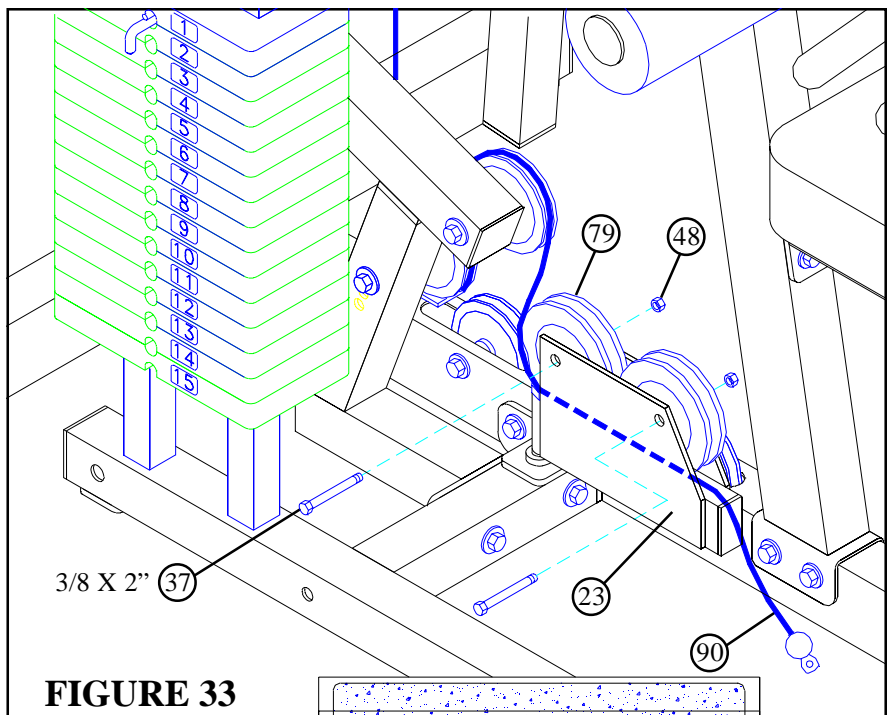
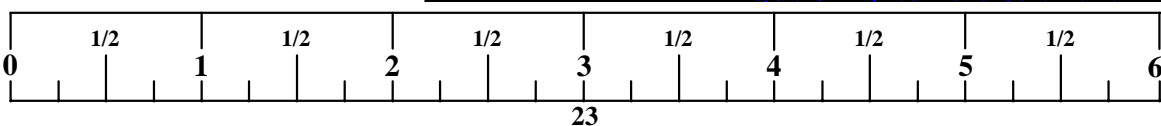
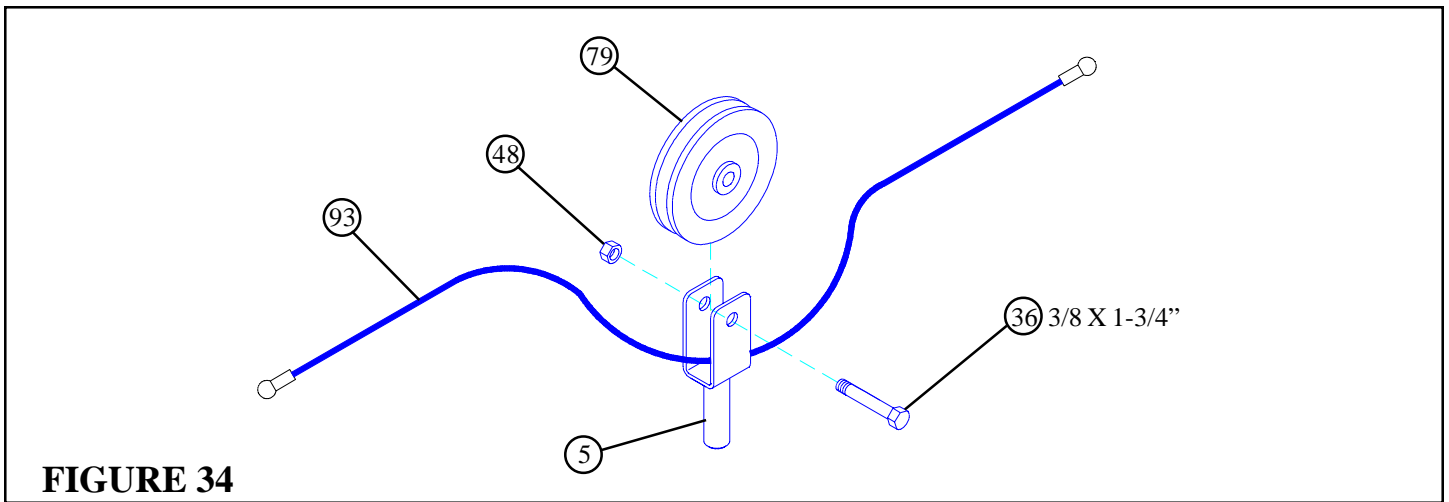

FIGURE 33





STEP 34

- Assemble one 3-1/2" PULLEY (79) around the PEC DEC CABLE (93) and to the PULLEY BRACKET (5) using one 3/8 X 1-3/4" BOLT (36) and one 3/8" LOCKNUT (48) as shown in FIGURE 34.

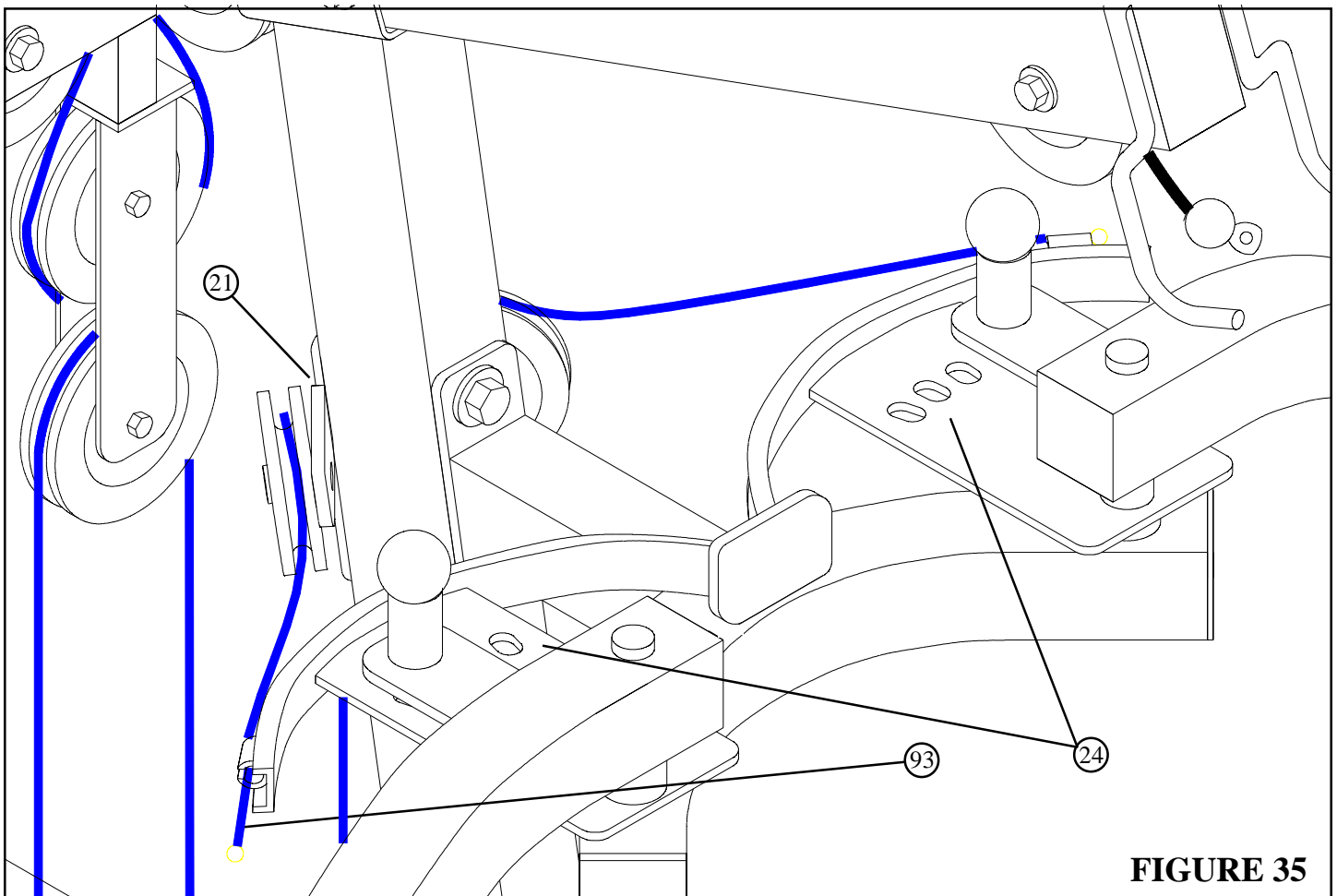

STEP 35

- Slide the ends of the PEC DEC CABLE (93) into the bushings on the PEC CAMS (24) as shown on FIGURE 35.
- Lay the PEC DEC CABLE (93) over the pulleys and under the cable retaining clips in the CENTER PULLEY BRACKET (21) as shown in FIGURE 35. (NOTE: The bolt holding pulley and cable retaining clips may need to be loosened to align cable retaining clips with cable.)

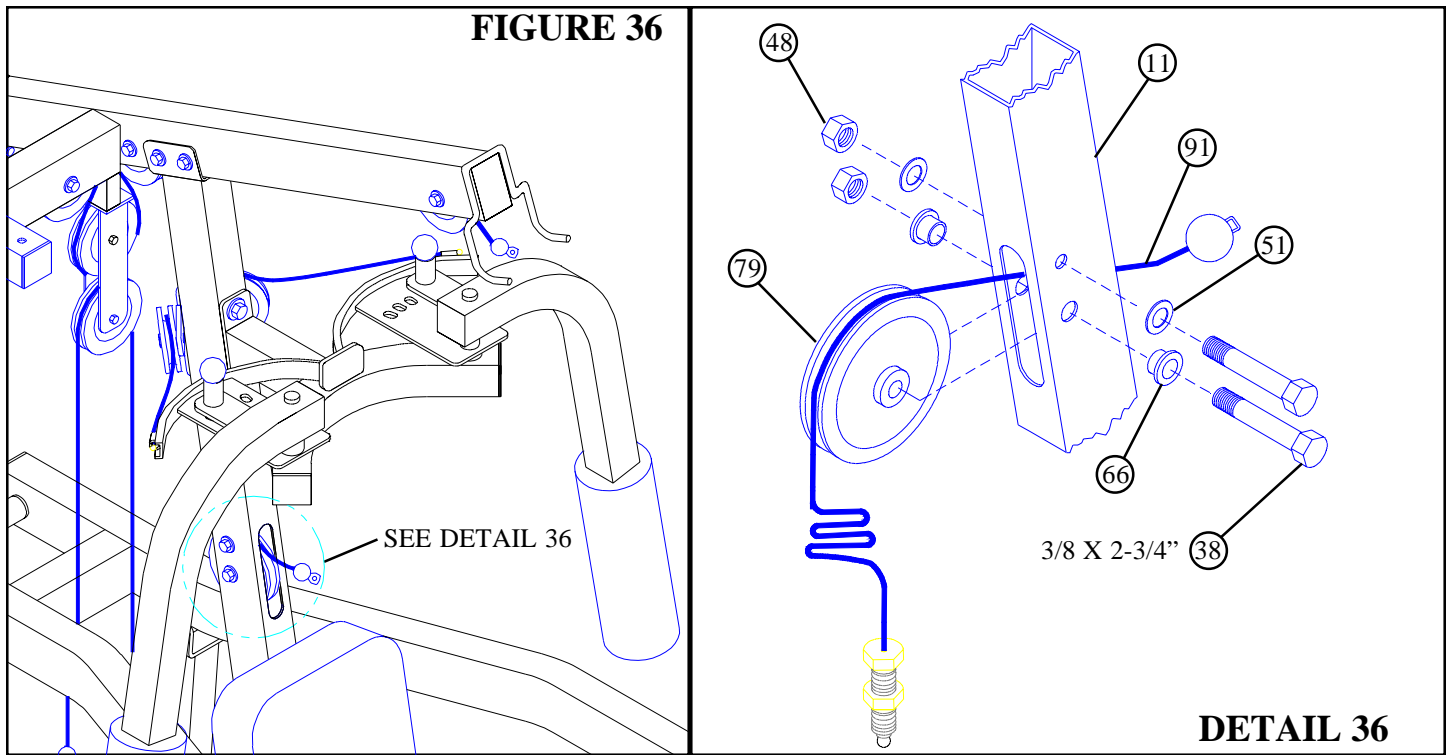

STEP 36

- Securely assemble the ball end of the AB CABLE (91) and one 3-1/2" PULLEY (79) to the FRONT UPRIGHT (11) using two 3/8 X 2-3/4" BOLTS (38), two 3/8" FLANGE SPACERS (66), two 3/8" WASHERS (51), and two 3/8" LOCKNUTS (48). (NOTE: The AB CABLE (91) should be routed underneath the retaining bolt as shown in DETAIL 36.)

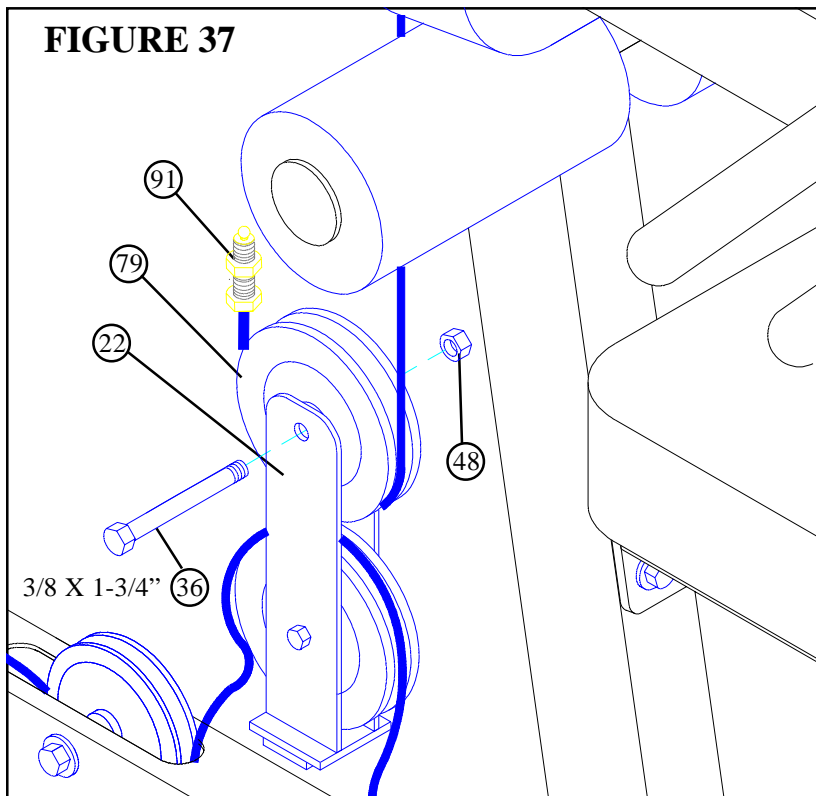

STEP 37

- Route threaded end of AB CABLE (91) around 3-1/2" PULLEY (79) while assembling one 3-1/2" PULLEY (79) to the lower FLOATING PULLEY BRACKET (22) using one 3/8 X 1-3/4" BOLT (36) and one 3/8" LOCKNUT (48) as shown in FIGURE 37.

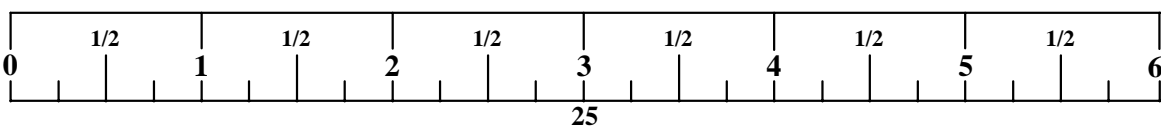

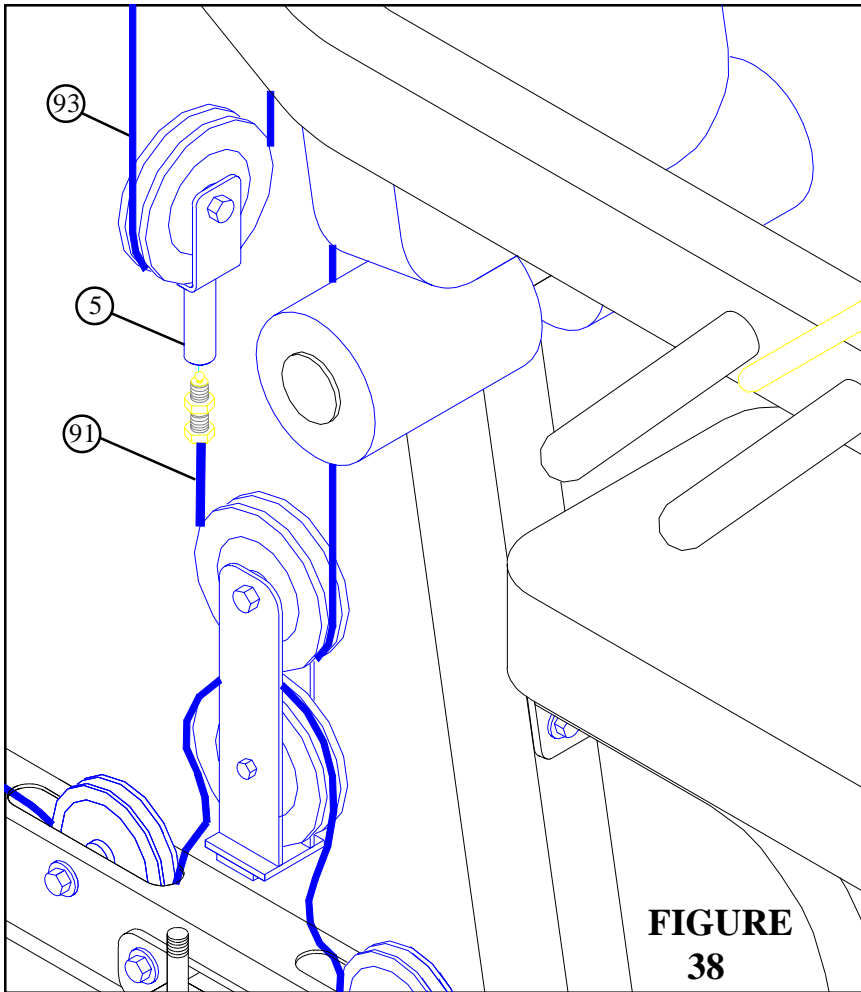

**FIGURE
38**

STEP 38

- Screw the threaded end of AB CABLE (91) approximately 3/4" into the end of the PULLEY BRACKET (5) and tighten jam nut securely as shown in FIGURE 38.
- **IMPORTANT!** Make sure the cables are running in the grooves of all pulleys.

CABLE ADJUSTMENT

For maximum performance, the HEAD PLATE should just barely sit on the top WEIGHT PLATE and the UPPER FLOATING PULLEY BRACKET should firmly contact the PLATE on the TOPBOOM, and the LOWER FLOATING PULLEY BRACKET should firmly contact the BASE.

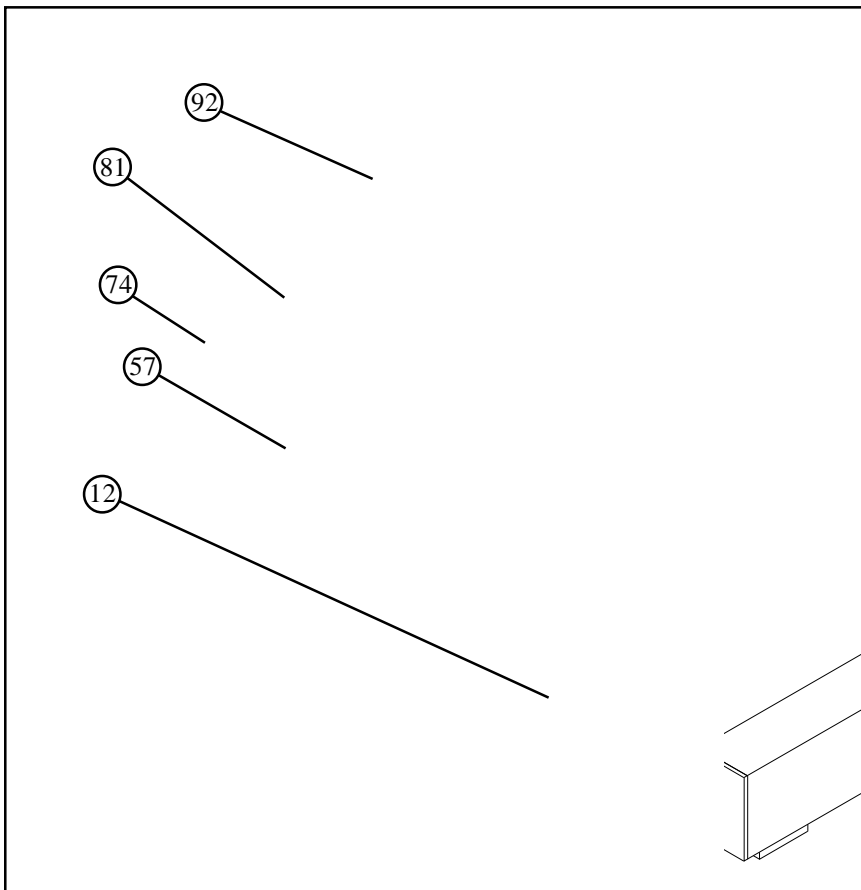

- The following adjustments can be made to adjust the cable tension:
- If upon completion of assembly, the HEAD PLATE (81) does not sit on top of the first WEIGHT PLATE (74), push the HEAD PLATE (81) down, insert the WEIGHT STACK PIN (57) and perform several repetitions at the press station. This will relax the cable system and prevent the HEAD PLATE (81) from lifting up.
- If after completing previous step, the HEAD PLATE (81) still does not sit on top of the first WEIGHT PLATE (74) or if there is excess slack in the cable system, adjust the threaded end of the LAT CABLE (92) accordingly and retighten the jam nut.
- If there is excess slack in the LEG CABLE, move the PULLEY attached to the LEVER STOP (12) down one hole.
- If there is excess slack in the AB or PEC DEC cable system, adjust the threaded end of the AB CABLE (91) accordingly and retighten the jam nut.
- **IMPORTANT!** Retighten both jam nuts when adjustment is completed.

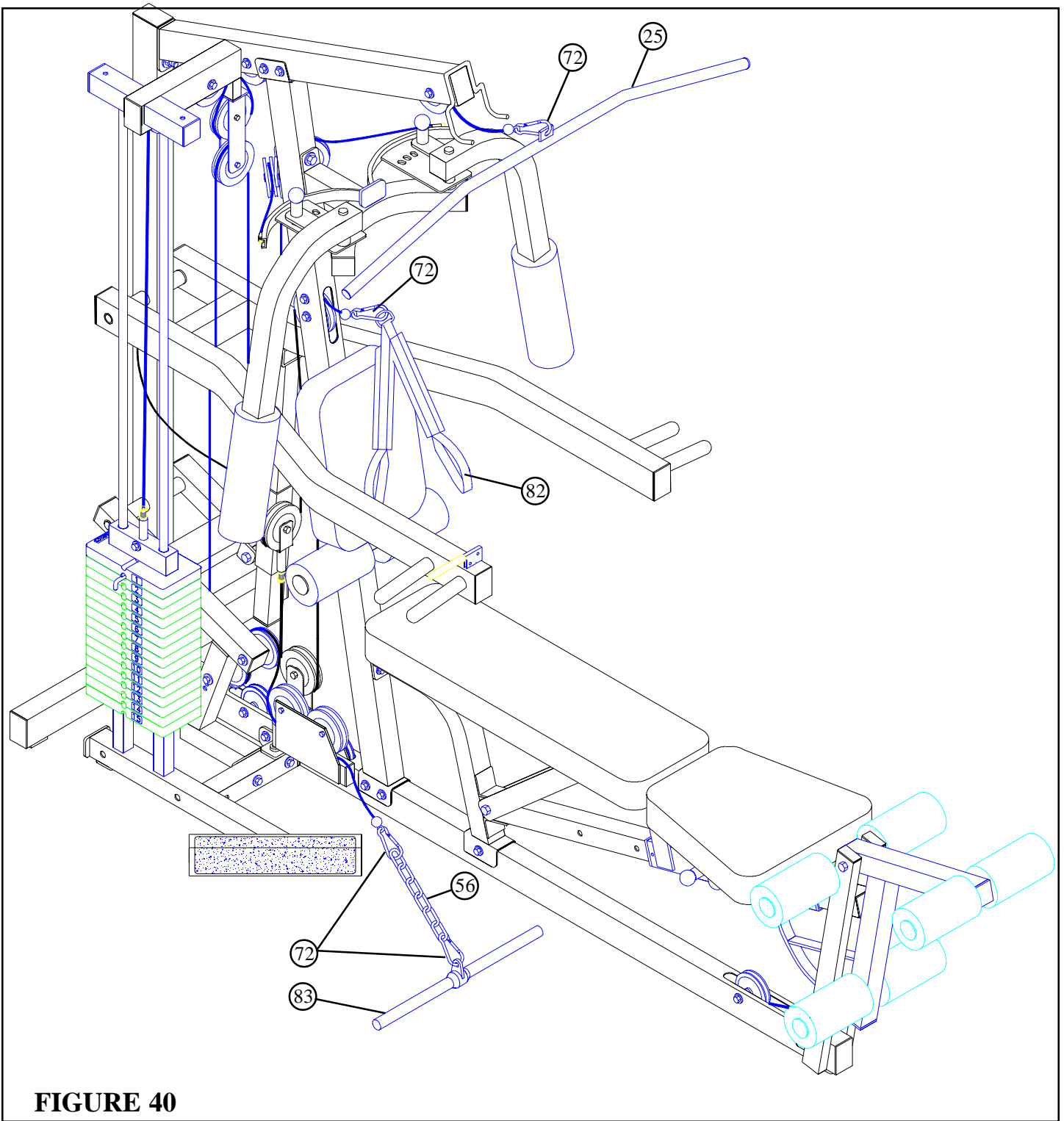
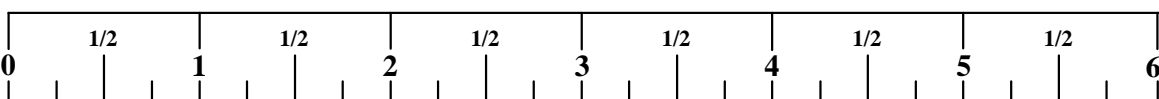

FIGURE 40

STEP 40

- Attach the LAT BAR (25) to the ball end of cable using one 5/16" SNAP LINK (72).
- Attach the AB CRUNCH STRAP (82) to the ball end of cable using one 5/16" SNAP LINK (72).
- Attach the LOW ROW BAR to the ball end of cable using two 5/16" SNAP LINKS (72) and one CHAIN (56).

Thank you for purchasing the Parabody 400101 Home Gym. If unsure of proper use of equipment, call your local Parabody distributor or call the Parabody customer service department at (800) 328-9714.



Free Manuals Download Website

<http://myh66.com>

<http://usermanuals.us>

<http://www.somanuals.com>

<http://www.4manuals.cc>

<http://www.manual-lib.com>

<http://www.404manual.com>

<http://www.luxmanual.com>

<http://aubethermostatmanual.com>

Golf course search by state

<http://golfingnear.com>

Email search by domain

<http://emailbydomain.com>

Auto manuals search

<http://auto.somanuals.com>

TV manuals search

<http://tv.somanuals.com>