

PARABODY

Serious Steel

435104 LEG PRESS ADAPTER KIT

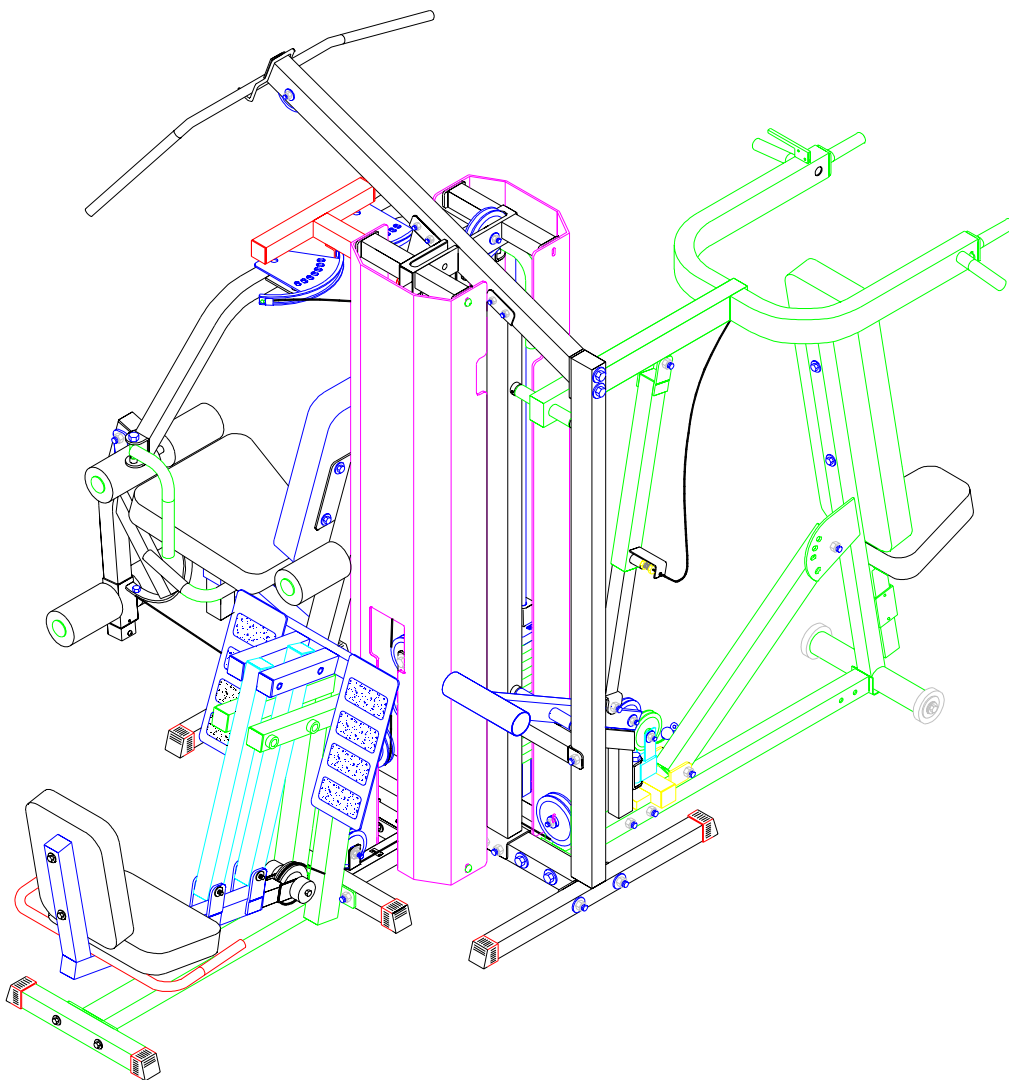

ASSEMBLY INSTRUCTIONS

IMPORTANT NOTES

WELCOME TO THE WORLD OF *Serious steel*!

Please note:

- * Thank you for purchasing the 435104 Leg Press Adapter Kit. Please read these instructions thoroughly and keep them for future reference. This product must be assembled on a flat, level surface to assure its proper function.
- * We recommend cleaning your product (pads and frame) on a regular basis, using warm soapy water. Touch-up paint can be purchased from your Parabody customer service representative at (800) 328-9714.

There is a risk assumed by individuals who use this type of equipment. To minimize risk, please follow these rules:

1. Inspect equipment daily. Tighten all loose connections and replace worn parts immediately. Failure to do so may result in serious injury.
2. Do not allow minors or children to play on or around this equipment.
3. Exercise with care to avoid injury.
4. If unsure of proper use of equipment, call your local Parabody distributor or call the Parabody customer service department at (800) 328-9714.

Tools Required for Assembly

- * Rubber mallet or hammer
- * 3/4" wrench
- * 9/16" wrench
- * Ratchet with 3/4" and 9/16" sockets
- * 7/32" Allen wrench
- * Adjustable wrench
- * Tape measure

Bolt Length Ruler

NOTE: BOLT LENGTH IS MEASURED FROM THE UNDERSIDE OF THE HEAD OF THE BOLT.

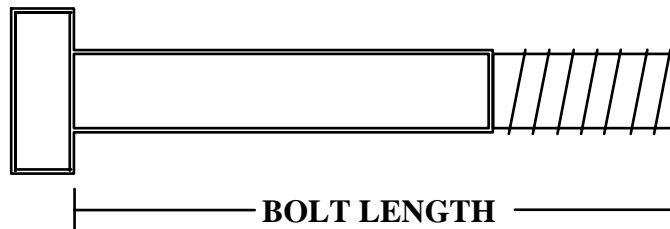

BOLT LENGTH RULER:

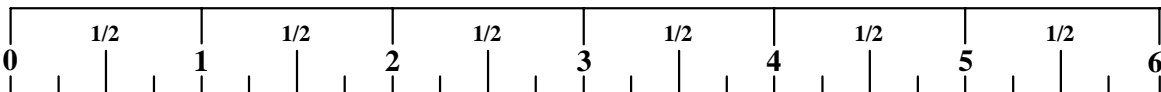

PARTS LIST

KEY	PART #	DESCRIPTION	QTY	KEY	PART #	DESCRIPTION	QTY
1	6747603	FRONT LEG	1	9	3102701	3/8" HEX NUT	2
2	3116202	3-1/2" PULLEY	2	10	3102501	3/8" WASHER	3
3	3108102	QUICK DISCONNECT LINK	1	11	3102802	3/8" LOCKNUT	2
4	6427101	KEYHOLE CLEVIS	1	12	3102502	1/2" WASHER	4
5	3118701	2" PULLEY	1	13	3102801	1/2" LOCKNUT	4
6	3201501	SWIVEL SNAP	1	14	3102902	3/8 X 2-1/4" BOLT	2
7	6271801	72" ELASTIC CORD	1	15	3102910	1/2 X 3" BOLT	4
8	6747901	LEG PRESS CABLE	1	16	3102909	3/8 X 1"	1

NOTE: The LEG PRESS ATTACHMENT (832101) must be assembled before connecting it to the PARABODY 425104 HOME GYM

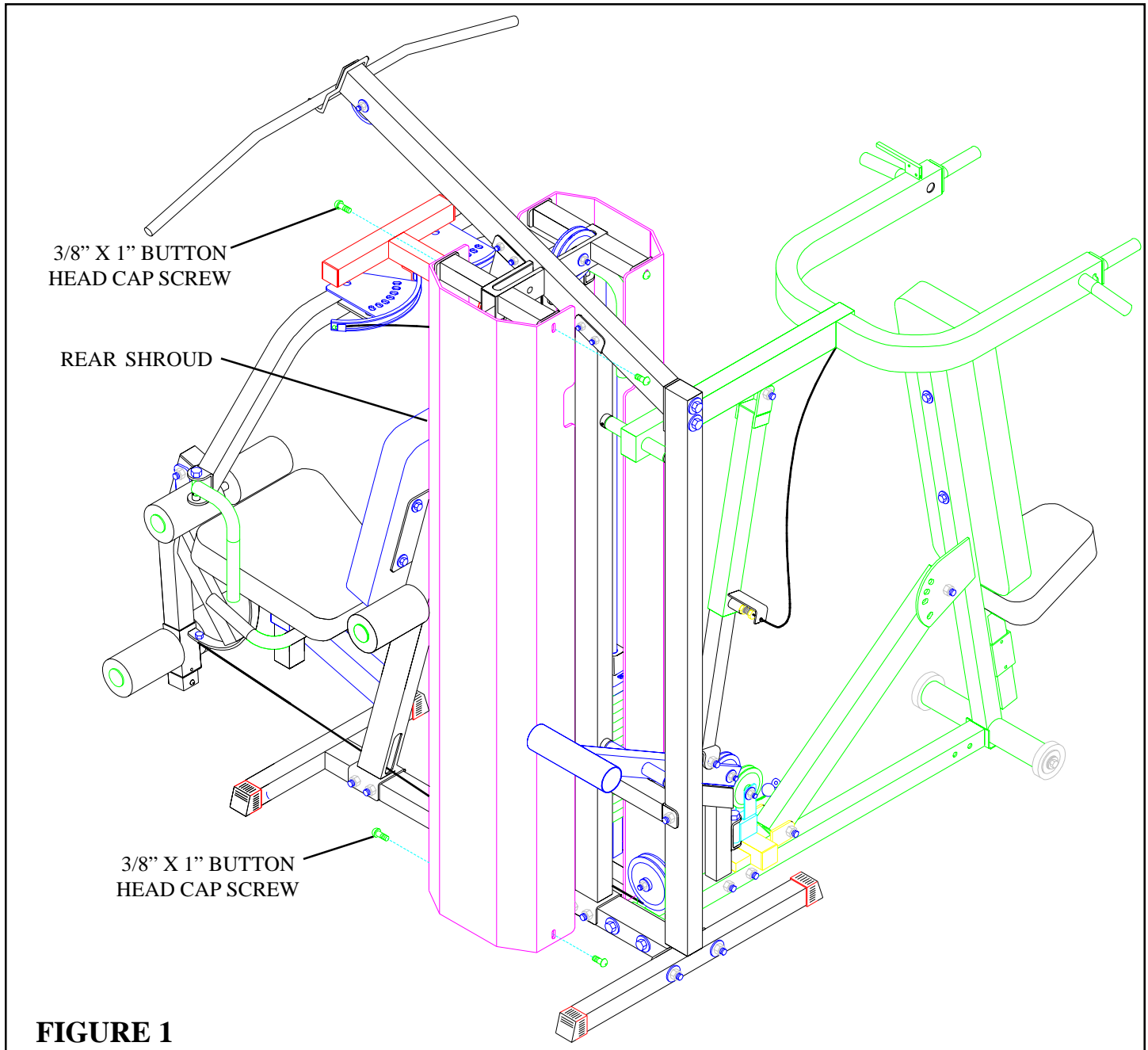

FIGURE 1

STEP 1

- **REMOVE** the four 3/8" X 1" BUTTON HEAD CAP SCREWS from the rear SHROUD. Remove the SHROUD from the 425104 HOME GYM. See FIGURE 1.



REAR
SHROUD

FIGURE 2

STEP 2

- If the 445104 SECOND STACK OPTION is not installed, the rear SHROUD opening must be removed. Apply pressure to the bottom of the SHROUD where the “V” groove is and carefully remove the weight stack opening on the SHROUD as shown in FIGURE 2.

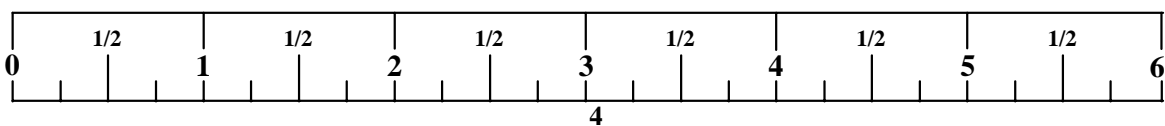

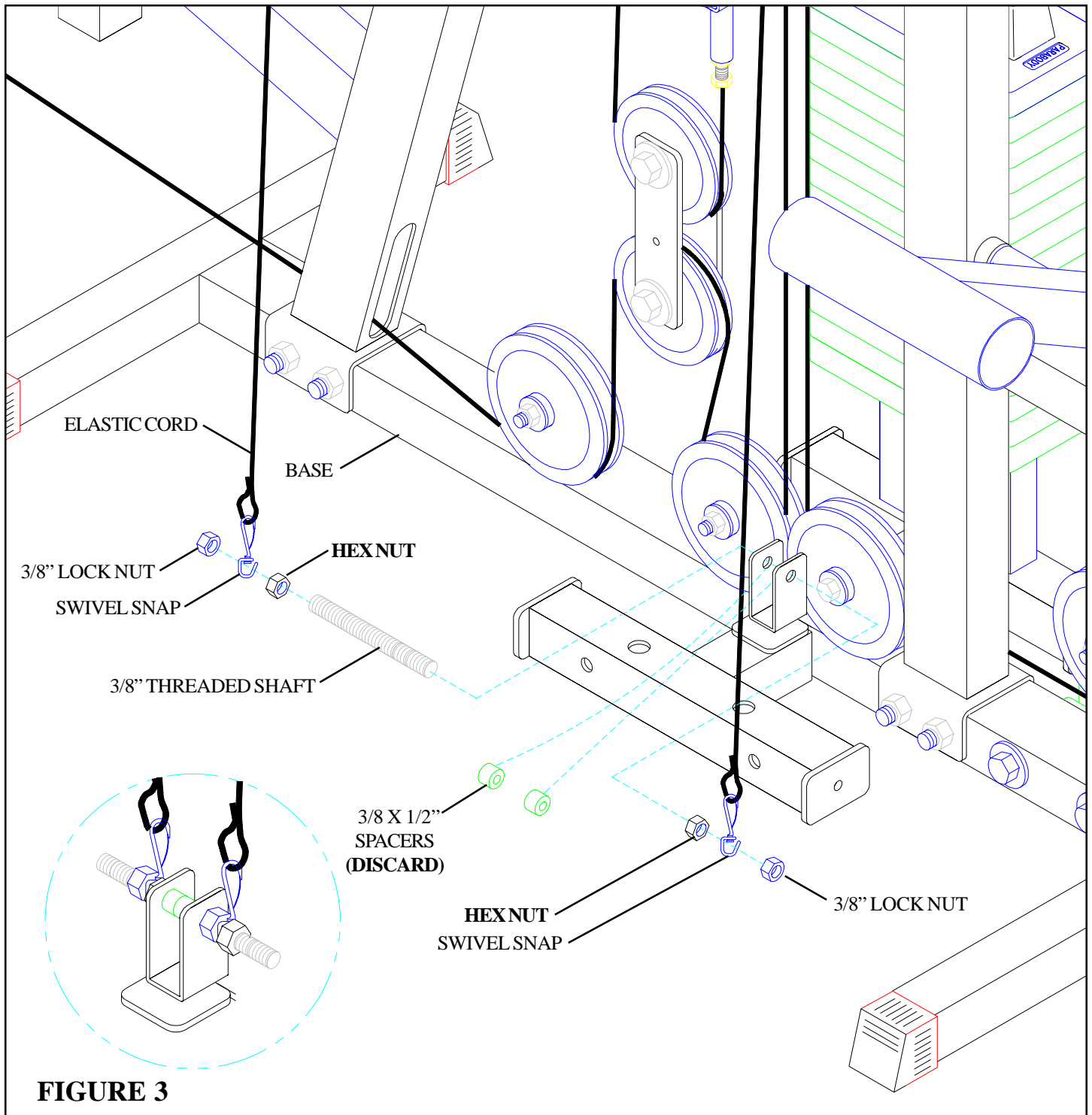

STEP 3

- Remove two 3/8" LOCK NUTS, two 3/8" HEX NUTS, two SWIVEL SNAP (68) (keep elastic cords attached), two 3/8 X 1/2" SPACERS, and one 3/8" THREADED SHAFT from the bracket on the BASE as shown in FIGURE 3.
- Discard the two 3/8 X 1/2" SPACERS.

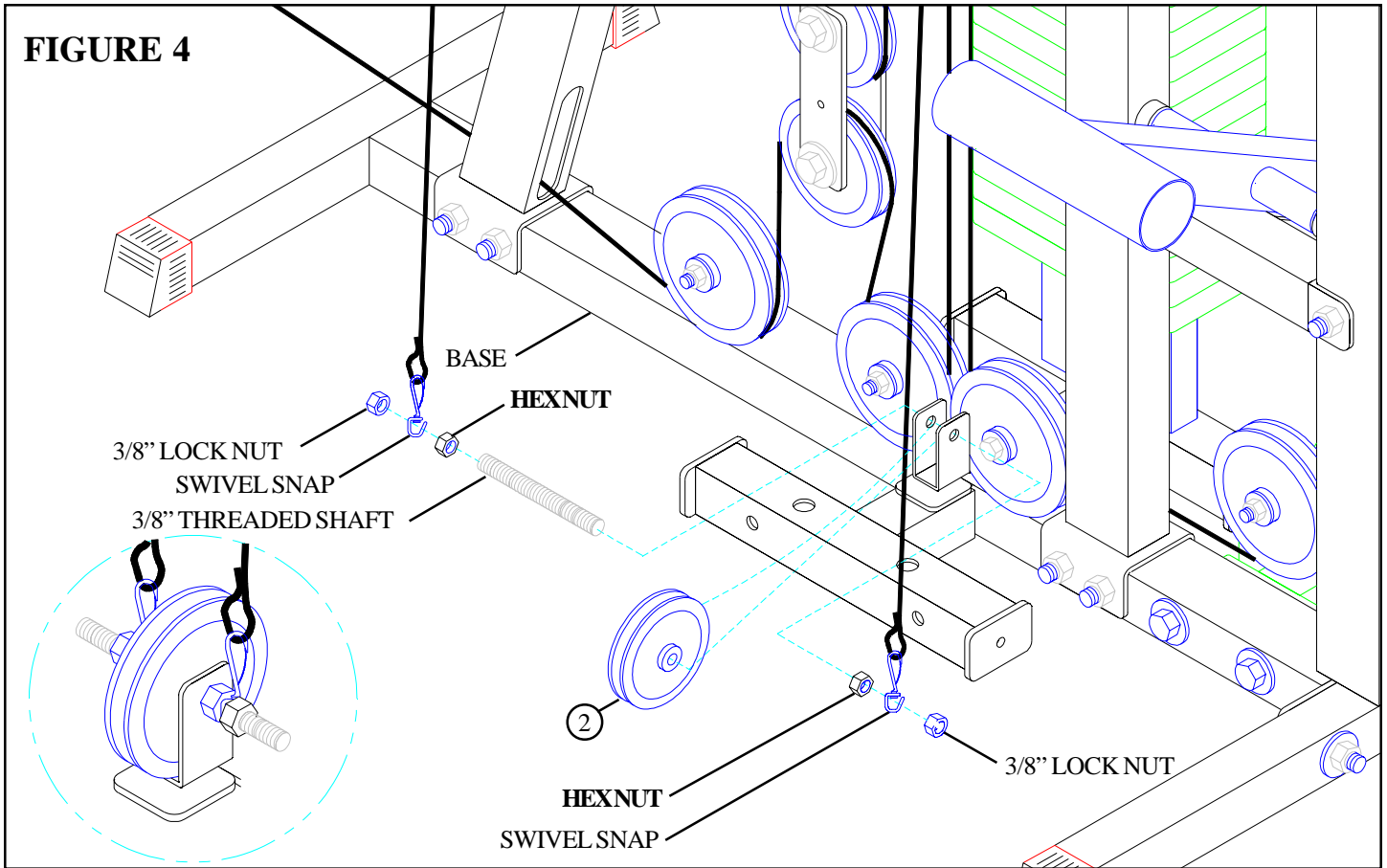

STEP 4

- Assemble the two previously removed 3/8" HEX NUTS, two previously removed SWIVEL SNAPS, one 3-1/2" PULLEY (2), and two previously removed 3/8" LOCK NUTS to the previously removed 3/8" THREADED SHAFT as shown in FIGURE 4.

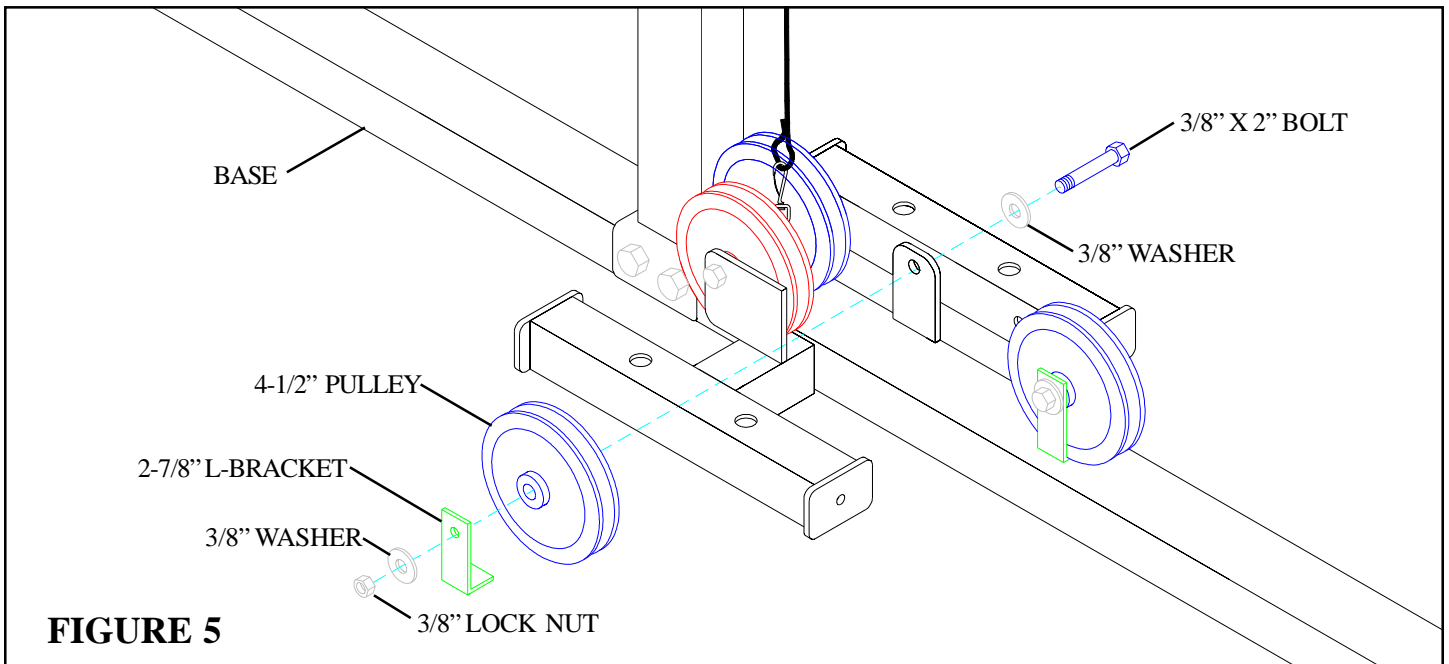

STEP 5

- Remove one 3/8 X 2" BOLT, two 3/8" WASHERS, one 2-7/8" L-BRACKET, one 4-1/2" PULLEY, and one 3/8" LOCK NUT from the upper flat on the BASE as shown in FIGURE 5.

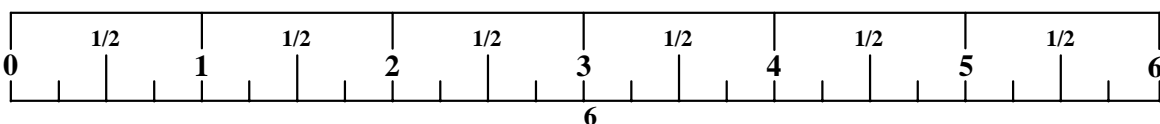

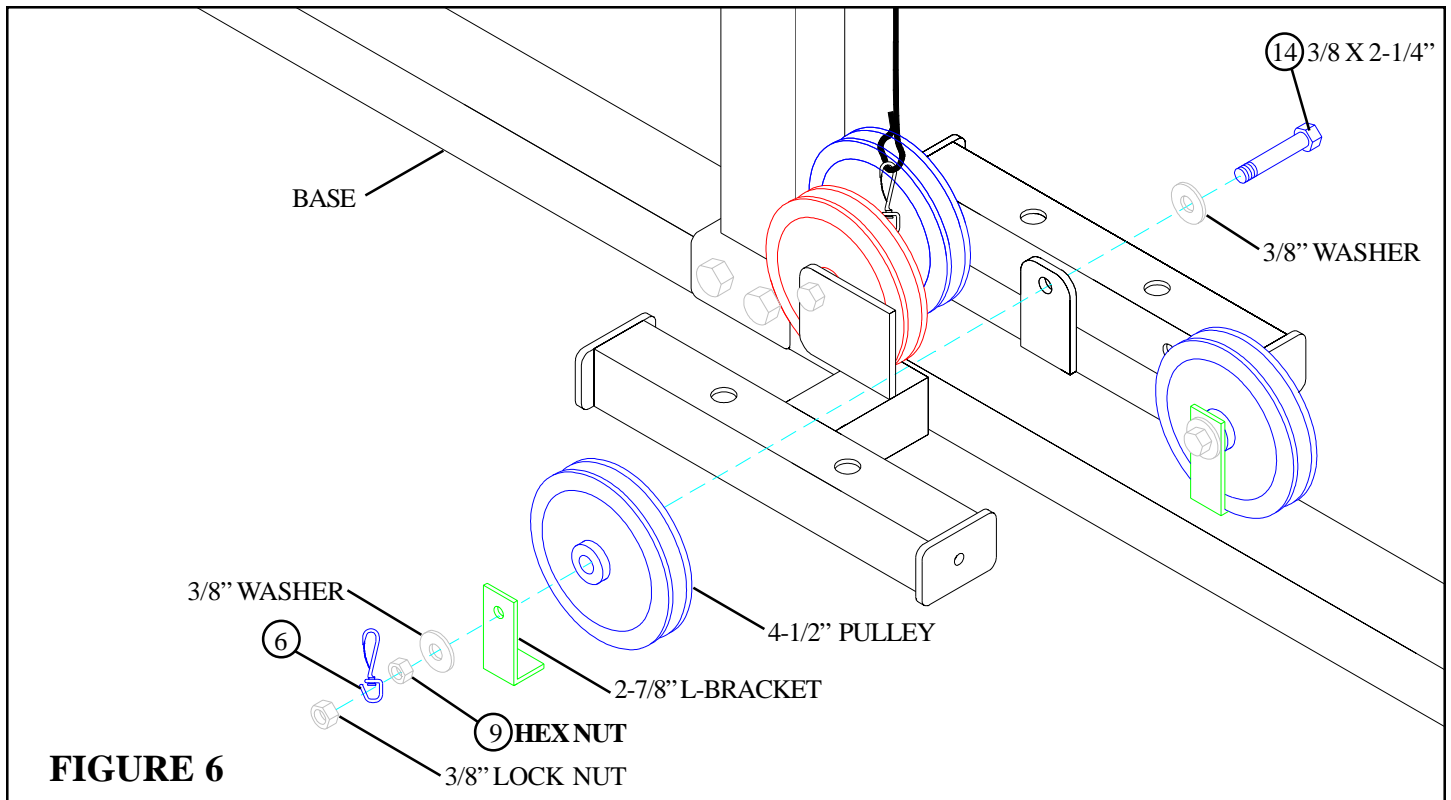
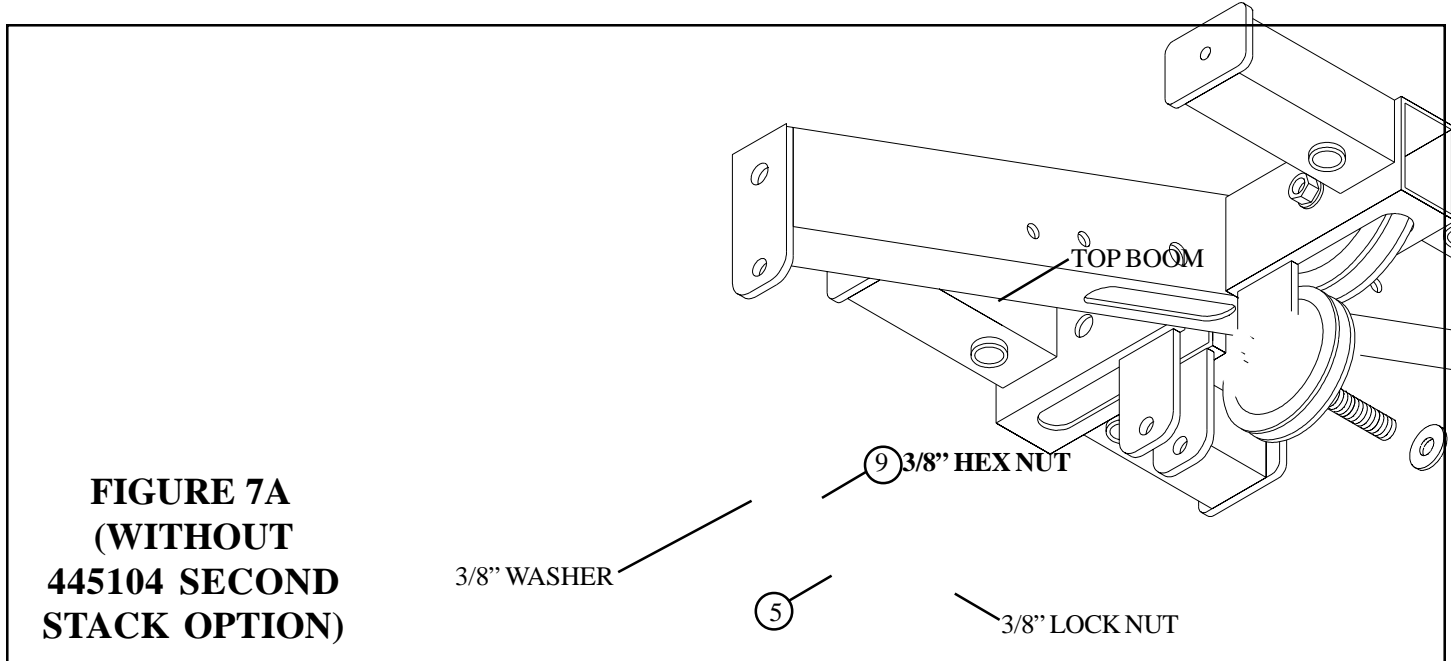

FIGURE 6

STEP 6

- **SECURELY** assemble the previously removed 4-1/2" PULLEY to the BASE using one 3/8 X 2-1/4" BOLT (14), two previously removed 3/8" WASHERS, one previously removed 2-7/8" L-BRACKET, one SWIVEL SNAP (6), one 3/8" HEX NUT (9), and one previously removed 3/8" LOCK NUT. See FIGURE 6.



**FIGURE 7A
(WITHOUT
445104 SECOND
STACK OPTION)**

STEP 7A

- If the 445104 SECOND STACK OPTION is installed follow STEP 7B .
- Remove one 3/8" WASHER and one 3/8" LOCK NUT from the 3/8" THREADED SHAFT on the TOP BOOM.
- **SECURELY** assemble one 2" PULLEY (5) to the 3/8" THREADED SHAFT on the TOP BOOM using one previously installed 3/8" WASHER, one 3/8" HEX NUT (9) and one previously installed 3/8" LOCK NUT as shown in FIGURE 7A.

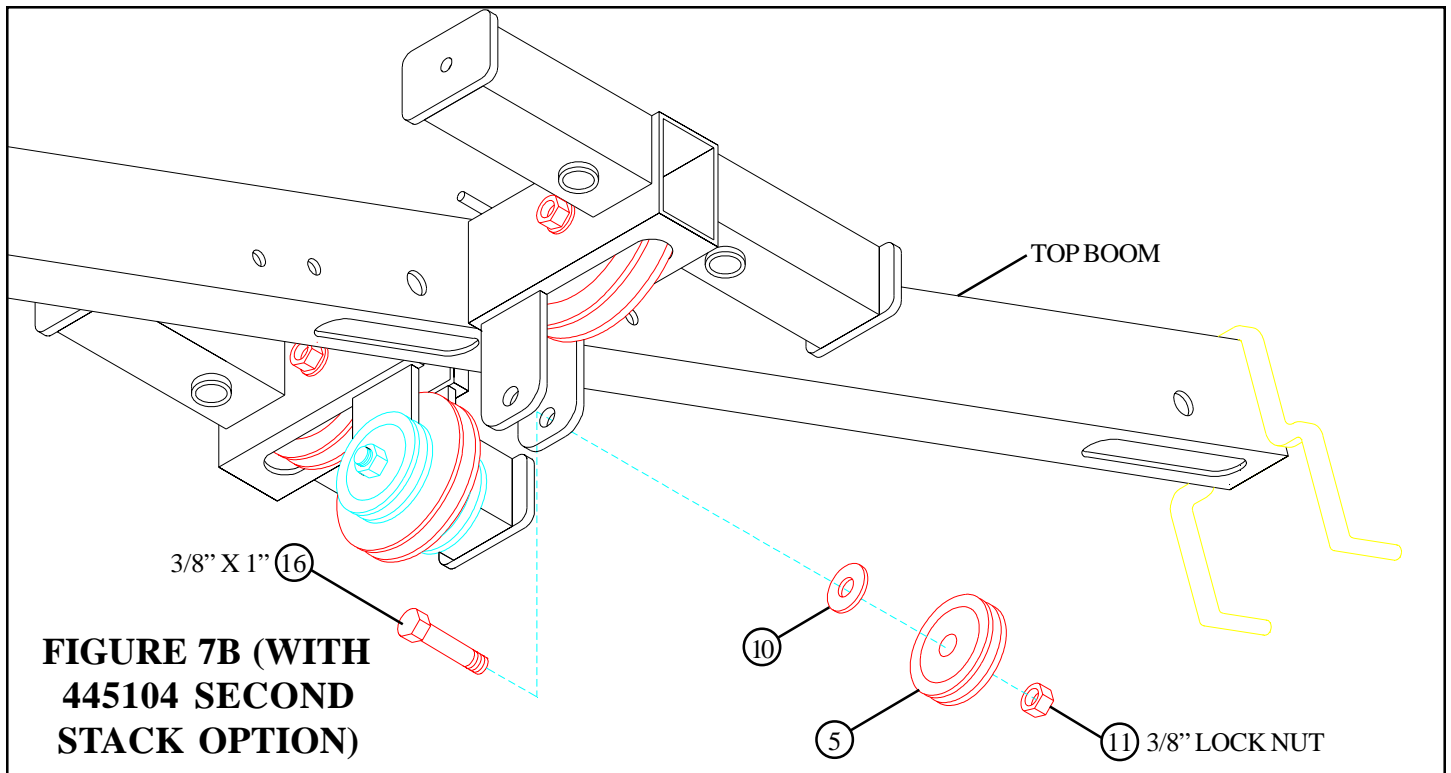

STEP 7B

- If the 445104 SECOND STACK OPTION is **NOT** installed proceed to STEP 8 .
- **SECURELY** assemble one 3/8 X 1" BOLT (16), one 3/8" WASHER (10), one 2" PULLEY (5) and one 3/8" LOCK NUT (11) to the bracket on the TOP BOOM as shown in FIGURE 7B.

STEP 8

- **SECURELY** attach one 3-1/2" PULLEY (2) to the FRONT LEG (1) using one 3/8 X 2-1/4" BOLT (14), two 3/8" WASHERS (10), and one 3/8" LOCK NUT (11). See FIGURE 8.
- Attach the open end of PRESS LINK CABLE (8) to the QUICK DISCONNECT LINK (3). See FIGURE 8.
- **SECURELY** tighten the QUICK DISCONNECT (3) to the tab on the FRONT LEG (1) as shown in FIGURE 8.

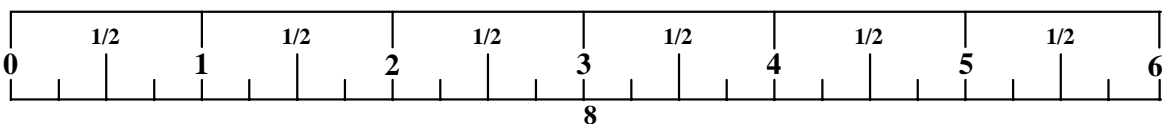
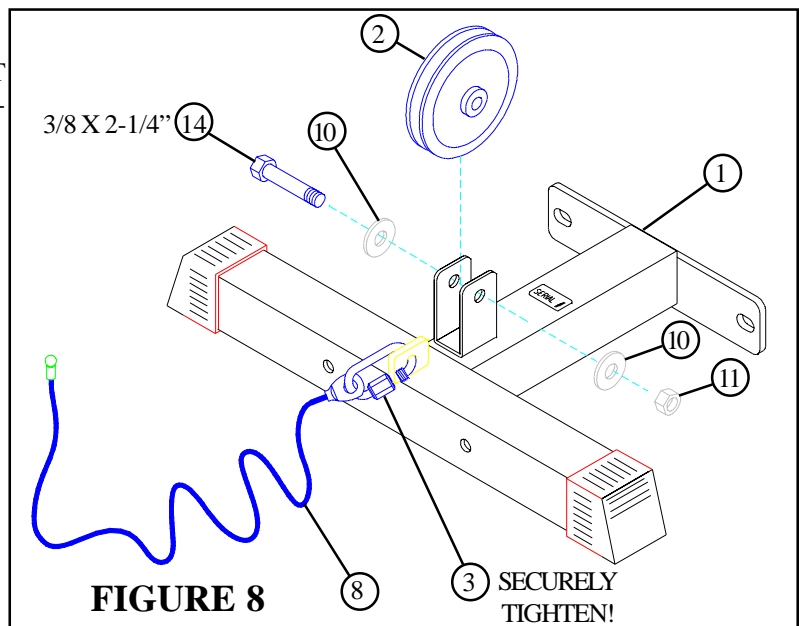

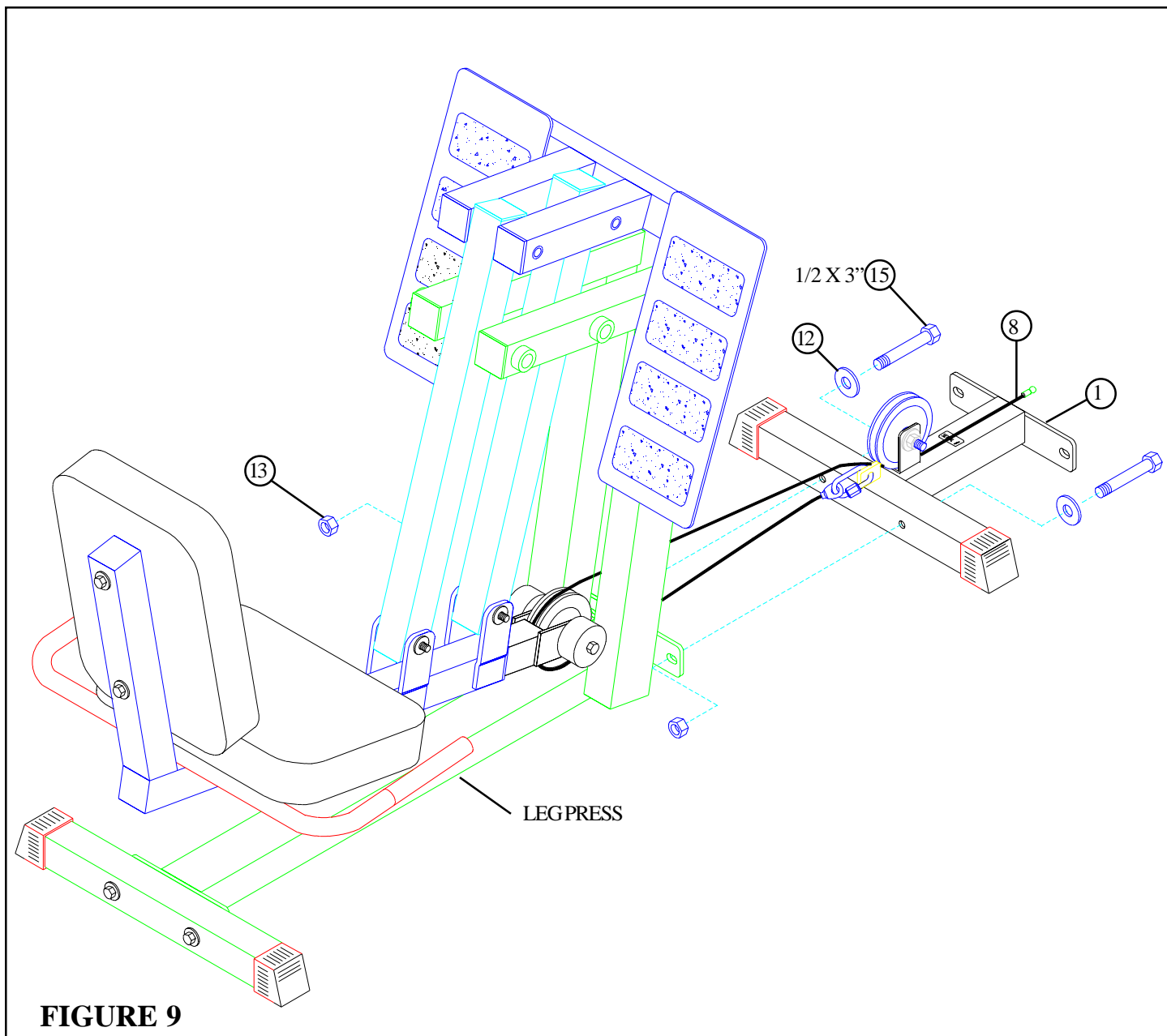

STEP 9

- **SECURELY** attach the LEG PRESS to the FRONT LEG (1) using two 1/2" X 3" BOLTS (15), two 1/2" WASHERS (12), and two 1/2" LOCK NUTS (13). See FIGURE 9.
- Route LEG PRESS CABLE (8) around the 3-1/2" PULLEY on the LEG PRESS and **UNDER** the 3-1/2" PULLEY on the FRONT LEG (1) as shown in FIGURE 9.

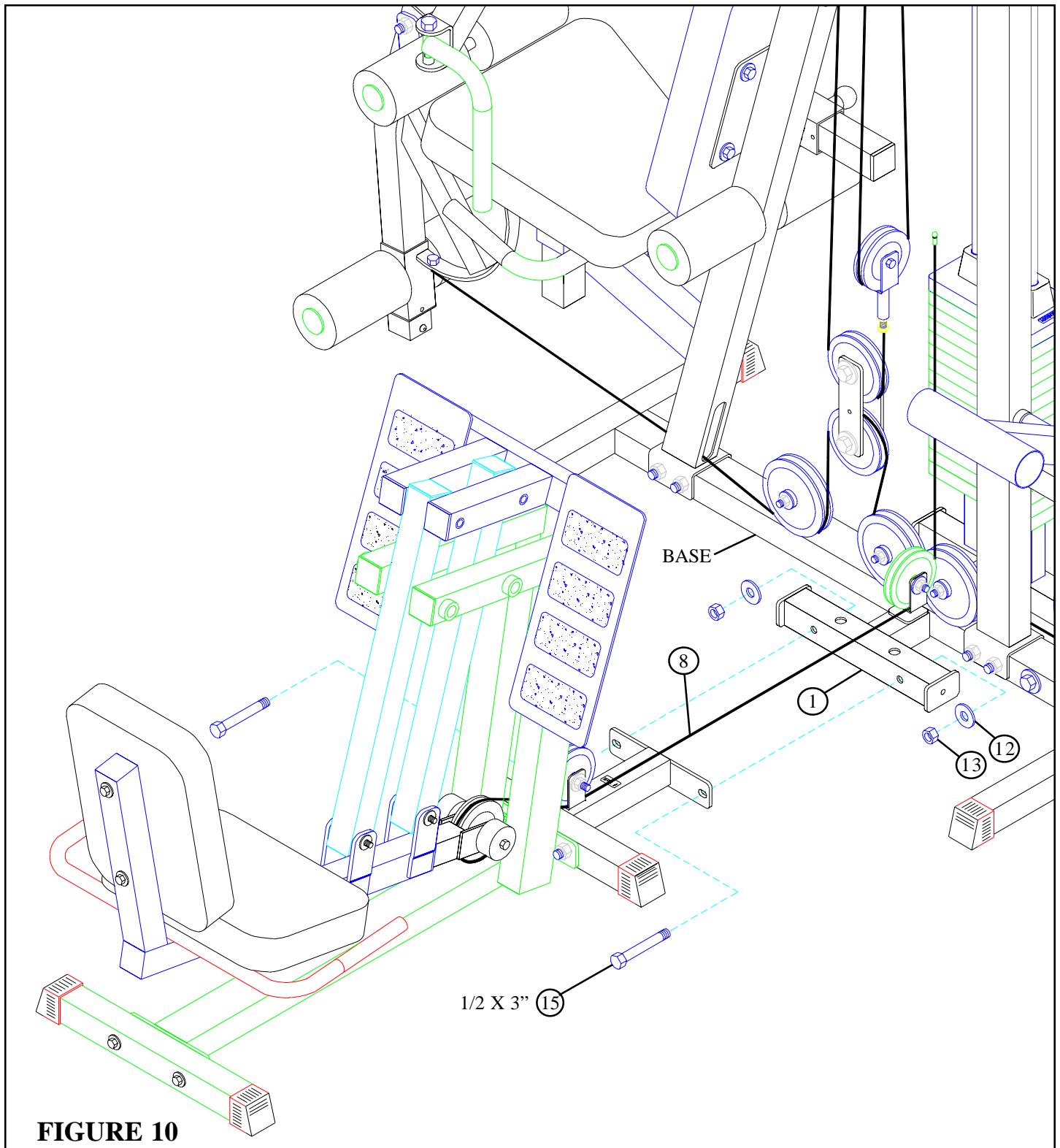
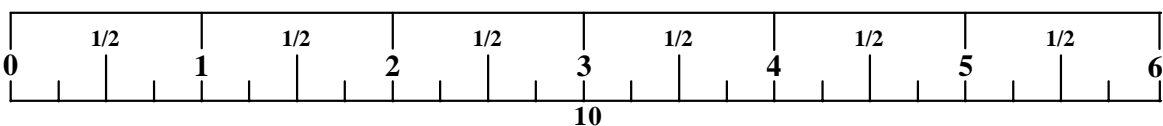
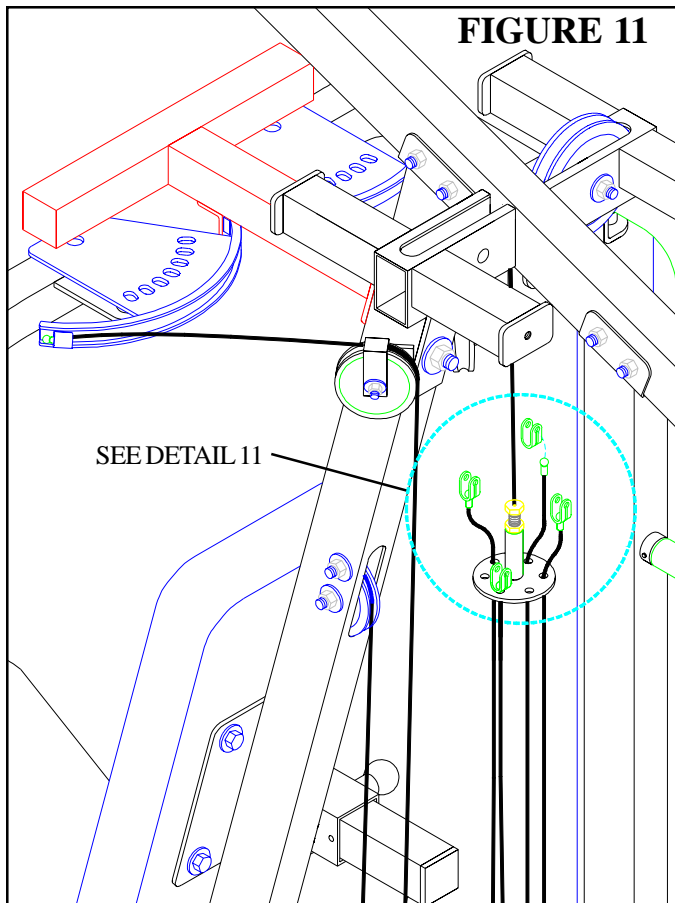

FIGURE 10

STEP 10

- **SECURELY** attach the FRONT LEG (1) to 425 BASE using two 1/2 X 3" BOLTS (15), two 1/2" WASHERS (12) and two 1/2" LOCK NUTS (13). See FIGURE 10.
- Route LEG PRESS CABLE (8) under the 3-1/2" PULLEY on the 425 BASE as shown in FIGURE 10.





DETAIL 11

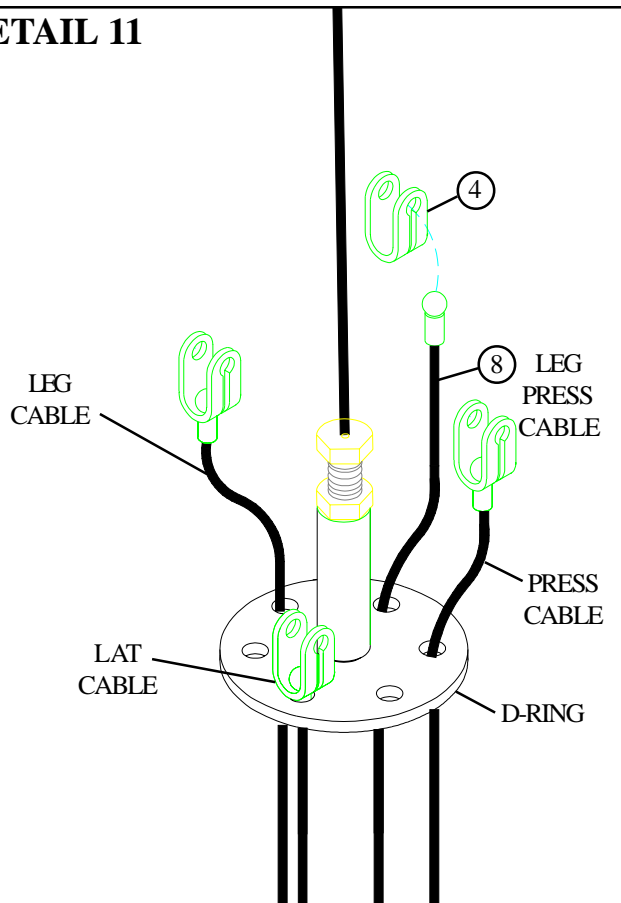

STEP 11

- Run the LEG PRESS CABLE through the correct hole on the d-ring and attach one KEYHOLE CLEVIS to the end of the LEG PRESS CABLE. See FIGURE 11 & DETAIL 11. (NOTE: If the 445101 SECOND STACK kit is installed, evenly space the LAT & LEG EXT. CABLES on the D-RING)

STEP 12

- Assemble one 72" ELASTIC CORD (7) to the KEYHOLE CLEVIS (4) as shown in FIGURE 12.

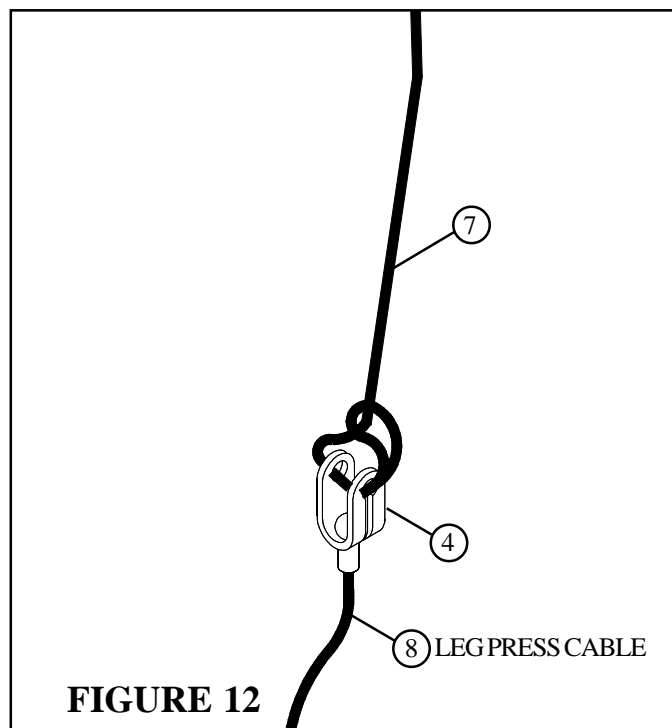
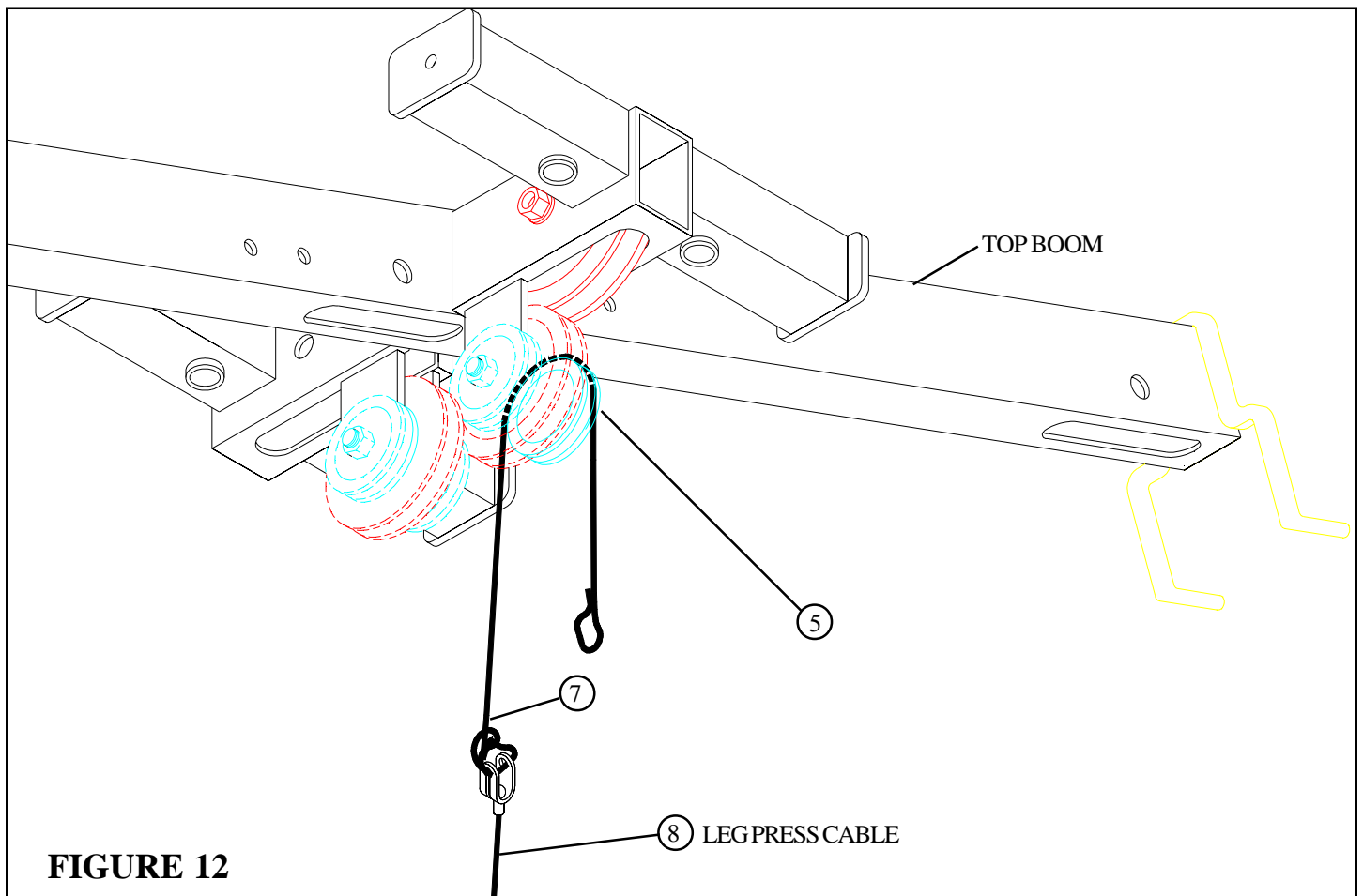

FIGURE 12



STEP 12

- Assemble the 72" ELASTIC CORD (7) from the LEG PRESS CABLE (8) around the 2" PULLEY (5) in the TOP BOOM as shown in FIGURE 12.

STEP 13

- Assemble the ELASTIC CORD (7) from the LEG PRESS CABLE to the corresponding SWIVEL SNAP (6) on the BASE as shown in FIGURE 13.

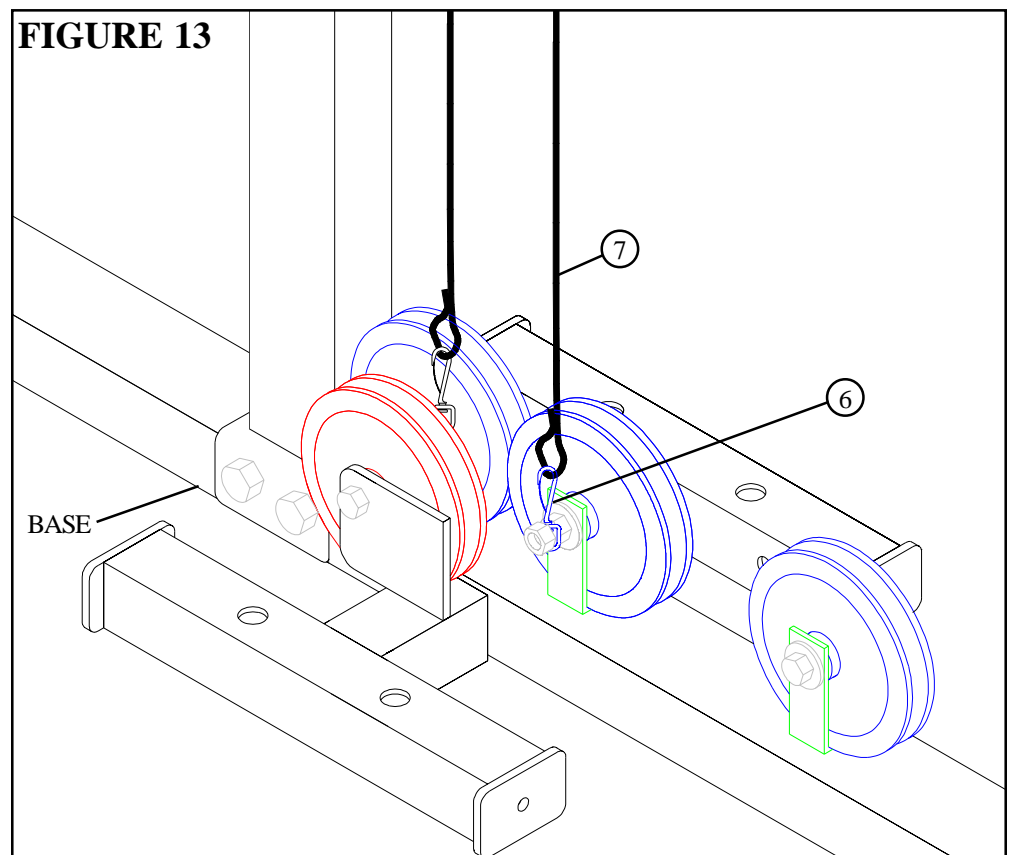

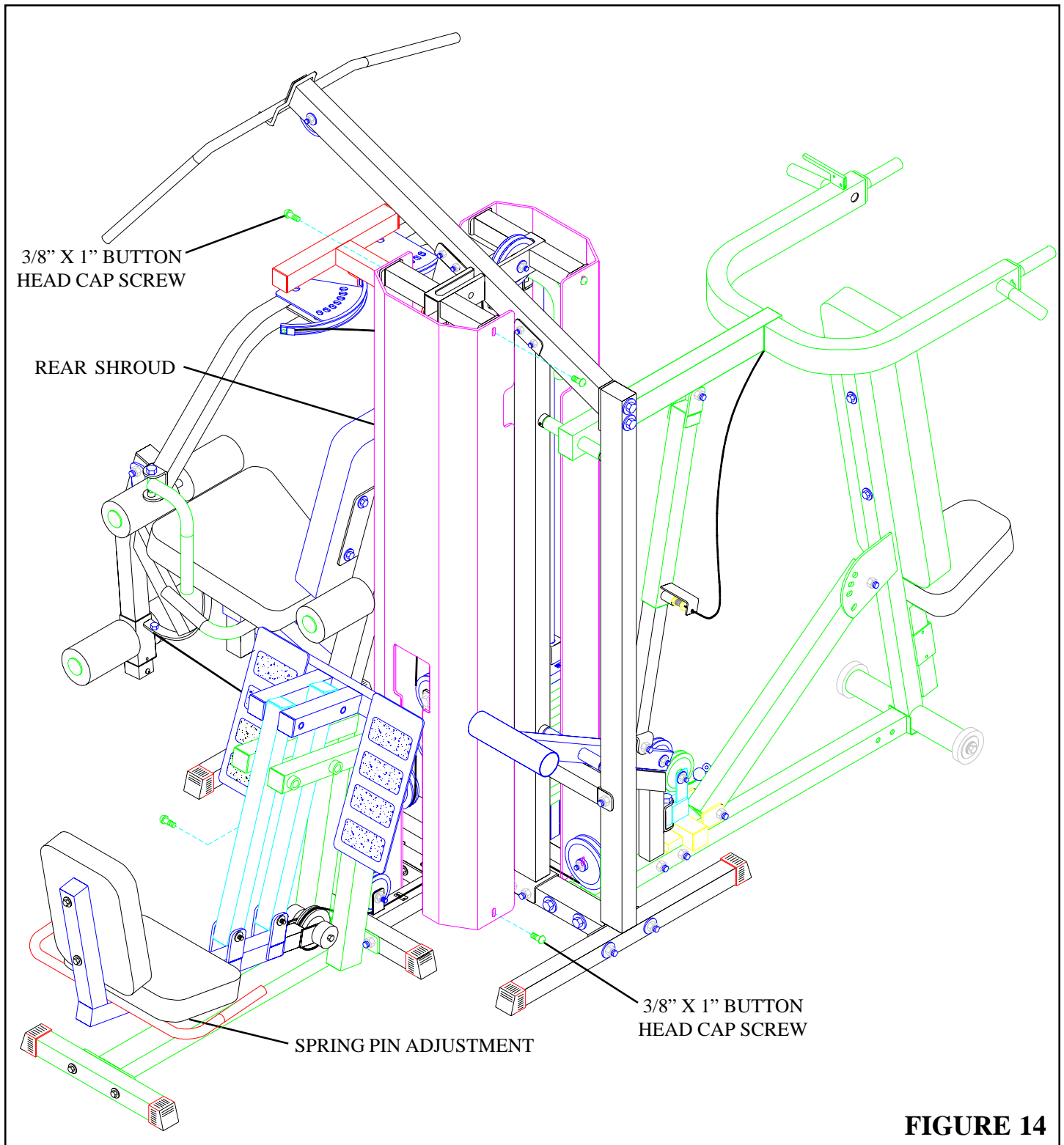

FIGURE 14

STEP 14

- **SECURELY** attach the four previously removed 3/8 X 1" BUTTON HEAD CAPSCREWS to the rear SHROUD. See FIGURE 14.
- The 832 LEG PRESS is equipped with a spring pin adjustment to accommodate different sized users and allow easy entry and exit from the machine. To use, you must slightly push against the foot plates to take tension off the pin.

Thank you for purchasing the Parabody 435104 Leg Press Adapter Kit. If unsure of proper use of equipment, call your local Parabody distributor or call the Parabody customer service department at (800) 328-9714.

Free Manuals Download Website

<http://myh66.com>

<http://usermanuals.us>

<http://www.somanuals.com>

<http://www.4manuals.cc>

<http://www.manual-lib.com>

<http://www.404manual.com>

<http://www.luxmanual.com>

<http://aubethermostatmanual.com>

Golf course search by state

<http://golfingnear.com>

Email search by domain

<http://emailbydomain.com>

Auto manuals search

<http://auto.somanuals.com>

TV manuals search

<http://tv.somanuals.com>